

# Force Flow Heaters

## Installation and Operation Manual

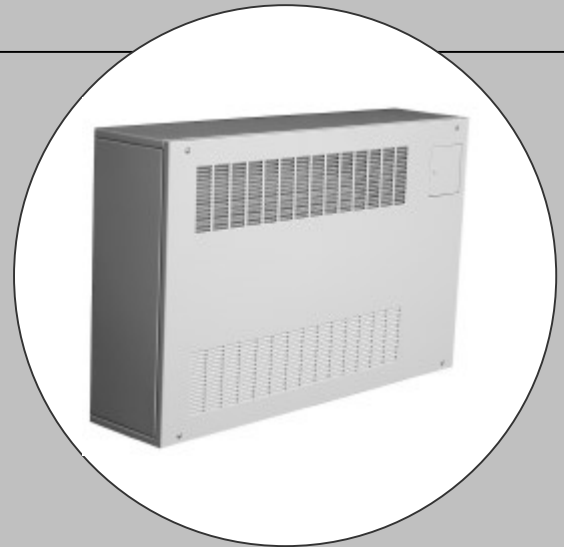

**MANUFACTURERS**

**OF HYDRONIC**

**HEATING**

**PRODUCTS**

[www.sigmaproducts.com](http://www.sigmaproducts.com) Tel: (905) 453-0446 Fax: (905) 453-0675

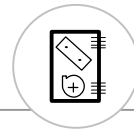

### GENERAL NOTES

1. Examine entire unit for damages in shipping upon receipt of the unit. Any shortages or damage should be noted on the carrier's delivery document. After inspection issue a purchase order for necessary parts or contact the factory for repair or replacement. Please do not return equipment without the prior authorization of the factory.
2. Installation and maintenance should only be performed by qualified personnel and in accordance with local codes and regulation.
3. Operate at maximum entering water temperature of 200°F (93°C).
4. For units not immediately installed storage should occur in a dry location with the motor protected from moisture, dust, corrosion and damage. If storing units for more than one year contact the motor manufacturer for further protection instructions.
5. **Caution;** sharp edges, coil surface and rotating fan are a potential hazard.

### ADDITIONAL WARNINGS

Familiarization with and adherence to national electrical code and local/state codes is highly recommended.

1. Avoid contact with energized circuits and/or rotating parts. Contact with operating voltage may be fatal.
2. Lifting of this unit should be done with care and in accordance with prescribed procedures.
3. Insure the unit is electrically grounded in accordance with code requirements.
4. Ensure unit is properly secured to prevent access by children or unauthorized persons in order to avoid possible accidents.
5. Avoid contact with capacitors until safe discharge procedures have been completed.
6. Do not under any circumstance restrict the motor ventilation.
7. If the unit has been subjected to storage in a damp environment dry out thoroughly before operating.

**FIGURE 1 MOTOR WIRING DIAGRAM**

**WARNING:**  
Failure to follow all safety information can result in serious personal injury or death. Before servicing, disconnect all power. This motor must be connected to the electrical service ground in accordance with local or national code. Consult a qualified electrician with any questions.

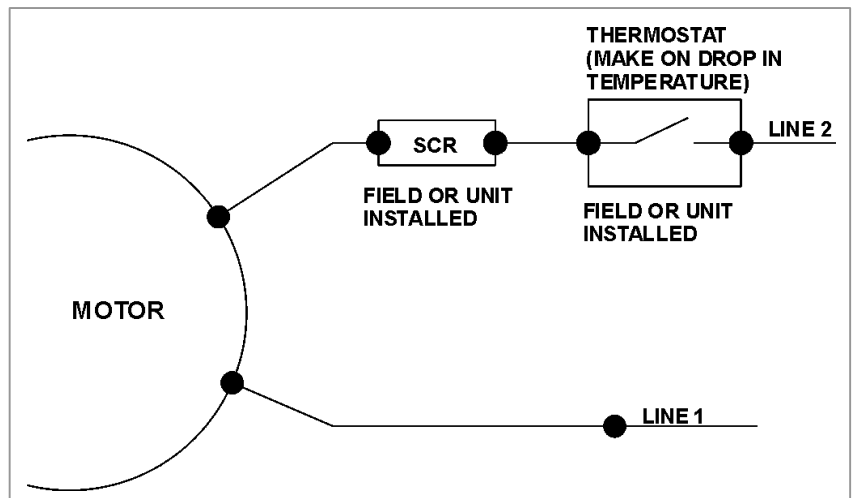

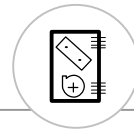

### GENERAL INSTALLATION

All units are shipped fully assembled. If the unit is a fully or semi-recessed model type then a wall seal trim will be included and must be installed as per the provided instructions.

Remove front panel, line up roughed in piping and position the unit in the desired wall or ceiling location.

Attach unit to wall or ceiling using the provided holes in the back panel of the unit.

Piping should always be installed and connected using good practice and in accordance with applicable codes.

Wiring should be completed in accordance with applicable codes. All models are furnished with a fan control box in the desired location on the unit. If the speed or temperature control are to be remote mounted the junction box must be supplied by an other.

Once the unit is completely installed a test run should be performed. If operational difficulties are experienced, recheck all wiring connections and power source.

### MAINTENANCE

**Motors.** Motors are a permanent split capacitor type fitted with self lubricating sleeve bearings. In order to extend motor life the bearing should be "recharged" with an annual lubrication. Use an SAE 10 non detergent oil applied only in the oiling holes provided.

**Coils.** Coils are to be kept clean in order for proper heat transfer to exist. The conditions of each operating environment will change the frequency of cleaning. The coils can be vacuumed or alternately use the following methods. Brush the fins on the air intake side and then place a bag or damp cloth over the unit discharge. Activate the unit and the dirt will be trapped in the bag or cloth. The coil can also be cleaned with high pressure air which should be blown on the outlet side of the coil (blowing air on the inlet will force dirt deeper into the coil).

**Blowers.** Blowers can be cleaned using high pressure air.

**Filters.** Filters should be kept clean to ensure the proper circulation of air volume through the unit. The frequency of the cleaning varies and is dependant upon the operating environment. As a guide they should be washed in mild detergent or blown clean with compressed air every 3 months.



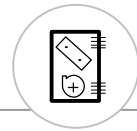

### UNIVERSAL FORCE FLOW COLLARS

A standard trim which is used on any semi-recessed or fully recessed model. Mounted on sight to allow for infinite mounting depth adjustment. Simply mark the depth location of the desired reveal minus 1/2" for the trim thickness and fasten the side bars centered with the front edge on the line. (Figure 4 shows sides being mounted to a fully recessed model wall mount)

The top and bottom bars have pocketed ends to provide quick and easy alignment. The protruding ends of the side bar (Figure 2 & 3) fit snugly in the pockets and provides the proper alignment for the top/bottom bar to be fastened to the cabinet. For floor mount units the bottom bar is not used and the sides are fastened even with the bottom of the unit and do not protrude. The collars have been designed for this so no cutting is required on the side bars. The top is mounted normally and the extra protrusion of the side bar does not affect the mounting.

**FIGURE 2**

**SIDES AND TOP  
ALIGNED AND  
READY TO BE  
FITTED**

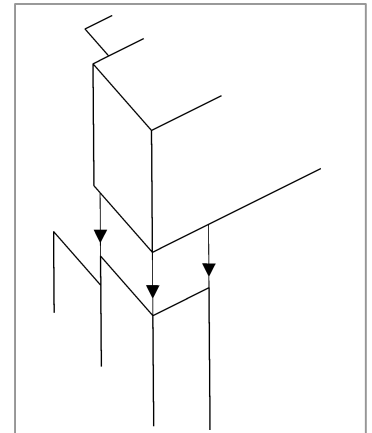

**FIGURE 3**

**ASSEMBLED SIDE  
AND TOP**

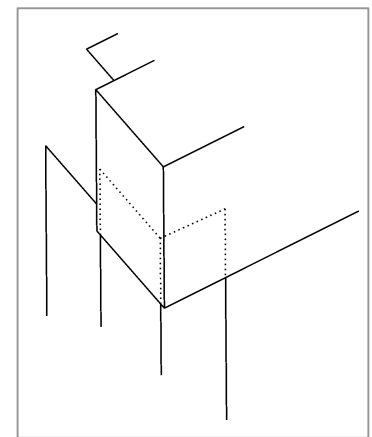

**FIGURE 4**

**ASSEMBLY VIEW FOR  
FULLY RECESSED  
UNIT**

