

peachtree

M25
ACTIVE MONITORS

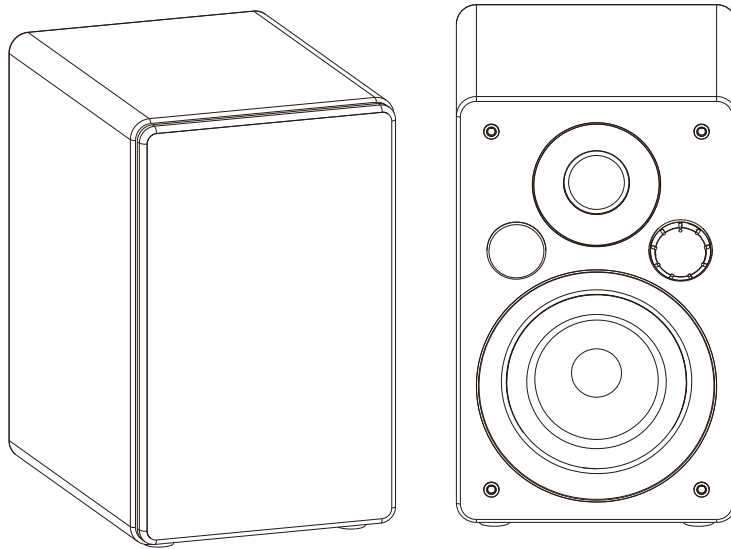

USER MANUAL

peachtree

M25
ACTIVE MONITORS

Contents

- 02 CONTENTS
- 03 SAFETY
- 04 INFORMATION
- 05 FRONT-AND REARPANEL
- 06 REMOTE CONTROL
- 07 CONNECTING YOUR SPEAKERS
BLUETOOTH FUNCTION
- 08 USB charge
- 09 PHONO
- 10 CONNECT TV, DVD, CONSOLE, PC
- 11 LIMITED WARRANTY
- 12 SPECIFICATIONS

Congratulations on your new M25 ACTIVE MONITORS.
Please take a moment to read this manual.
Enjoy

Safety

Safety Instructions

Please store this instruction manual for future reference.

- Do not use this product near water or moisture. Clean only with a dry cloth. Unplug this product from the wall outlet before cleaning.
- Place the unit on a solid surface. Do not block any ventilation openings.
- Do not put it in a closed bookcase or a cabinet that may keep air from flowing through its ventilation openings.
- Do not install near any heat sources, such as radiators, heat registers, stoves or other appliances that produce heat.
- Protect the power cord from being walked on or pinched, particularly at plugs and the point where they exit from the product.
- Servicing is required when the product has been damaged. Do not attempt to service this product yourself. Opening or removing covers may expose you to dangerous voltages or other hazards. Please contact the manufacturer to be referred to an authorized service center near you.
- To prevent risk of fire or electric shock, avoid over loading wall outlets, extension cords, or integral convenience receptacles.
- Do not let objects or liquids enter the product.
- Use proper power sources. Plug the product into a proper power source, as described in the operating instructions or as marked on the product.



peachtree

M25
ACTIVE MONITORS

Information

Unpacking

These speakers were carefully tested and inspected during production and before packaging and shipping. After unpacking please check for any damage. It is rare that a unit is damaged during shipping, but if this does happen contact your retailer immediately.

We recommend that you keep the original carton and packing material for future shipping.

Recommended Speaker Setup

Correct speaker placement has a huge impact on sound quality. There are many different theories, but all rooms and tastes are different so it's impossible to specify a correct placement. We do suggest you experiment with a few different locations see what is best for you.

For the best bass response on, we recommend that you keep a minimum distance of 20–25 cm between the speakers and the rear wall. For height, position the speakers with the tweeters at eye level of your most common listening position.

Speaker Conditioning and Break-in

Although a break-in period is not required, we recommend that you play between 24 to 48 hours of music through the speakers before doing any critical listening or speaker placement.

Speaker Cleaning

We don't recommend using any solvents or cleaners on cabinets or speaker drive units. Just wipe down with a soft, dry cloth.

peachtree

M25 ACTIVE MONITORS

Front-and rearpanel

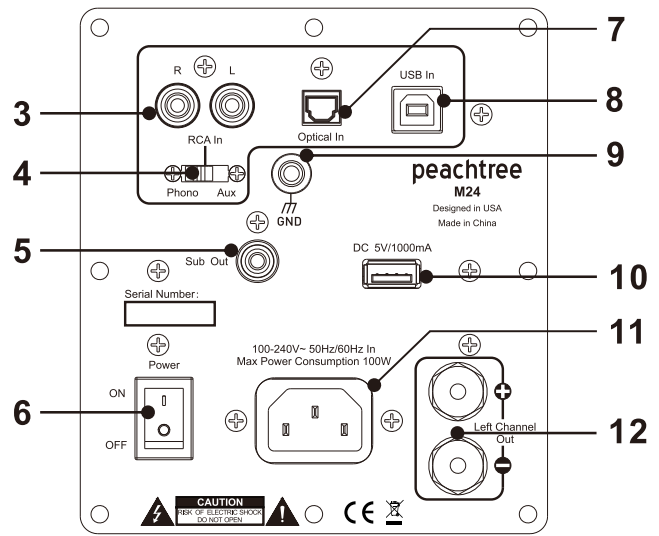
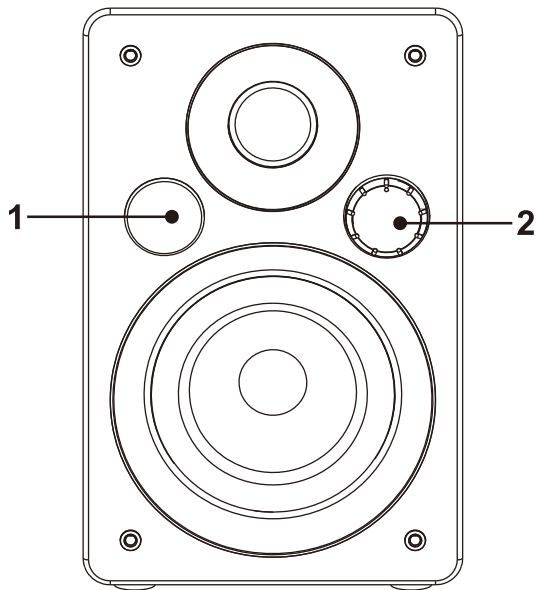

1. REMOTE RECEIVE WINDOW

- >Red: standby or Auto-Standby (after 30 minutes without playing)
- >Blinking RED: mute
- >White: ON
- >Blue: Bluetooth source is connected
- >Blinking Blue: Bluetooth source is disconnected

2. Increase / Decrease Volume / input select

3. Aux in

For right / left RCA stereo plugs, from CD / DVD / Home Theater player1. Phono (Phono / Line)

4. Phono (Phono / Line)

5. SUB out

6. Power On / Off

7. Optical audio in

8. USB Audio In (for PC connection only)

9. Ground Screw Terminal

10. Portable music device charge socket (DC 5V/1A)

11. Power supply input

12. Left speaker output

Signal output, for connecting the left passive LN01 speaker

Remote control

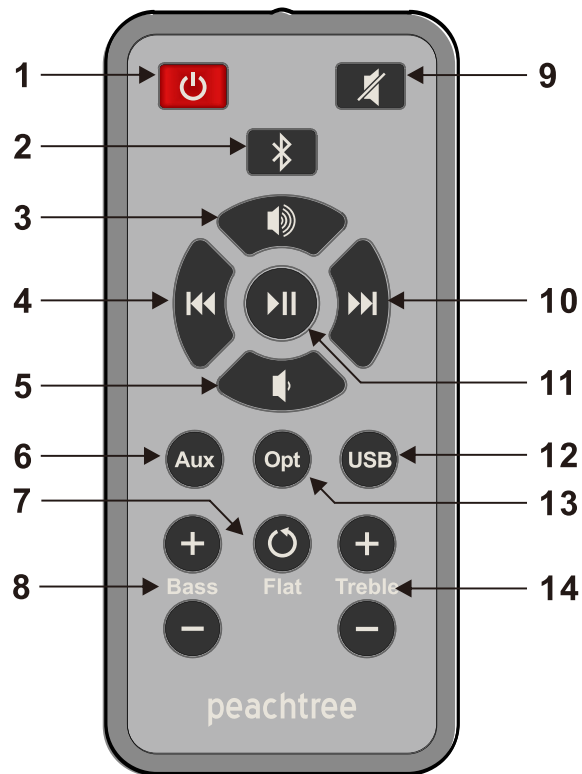

- | | |
|--|---|
| 1. Standby | 9. Mute button |
| 2. Bluetooth input | 10. Next track |
| 3. Volume button
Press "+", then volume will increase; | 11. Play/pause |
| 4. Prev track | 12. USB (PC Use) |
| 5. Volume button
Press "-", then volume will decrease; | 13. Digital in
Optical in |
| 6. RCA input mode | 14. Treble button
Press "-", then treble will decrease;
Press "+", then treble will increase; |
| 7. Reset
Reset bass and treble. | |
| 8. Bass button
Press "-", then bass will decrease;
Press "+", then bass will increase; | |

Connecting your speakers

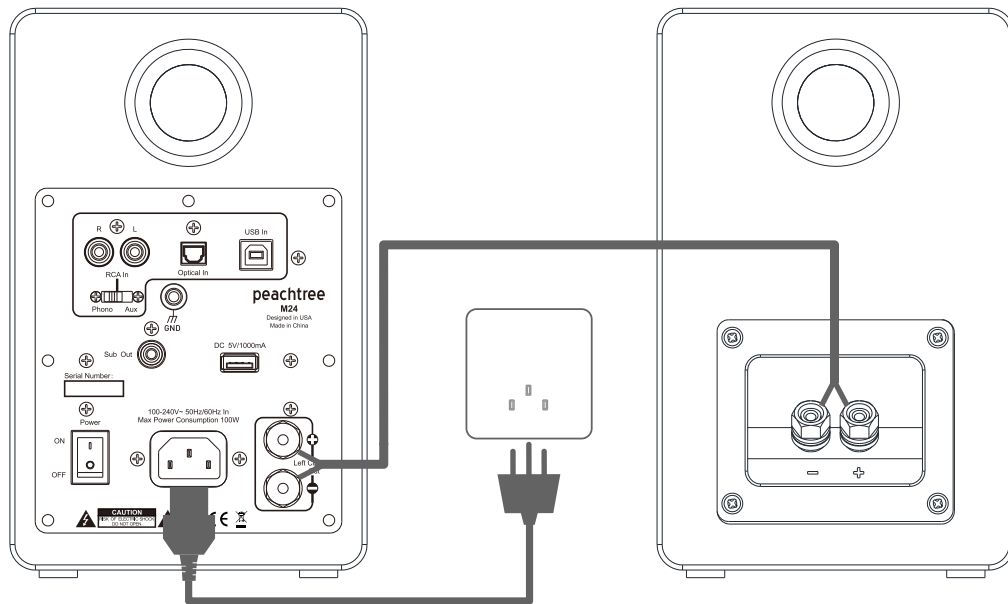

STEP 1

Connect the RED(+) and BLACK(-) terminals from the left speaker to the corresponding terminals on the right speaker using the included speaker cable. Insulation on cable must be stripped on all ends.

Note: Because this system is self-powered, do not connect the speaker terminals to the speaker outputs of a stereo receiver.

STEP 2

Connect the power cord into the left speaker and the other end into the wall outlet.

Bluetooth function

Pairing Bluetooth device and M25:

If you have a Bluetooth function audio device, such as phone, music player, computer, and connect it with M25, you should pair them as below:

1, power on M25 and select Bluetooth on Bluetooth function audio device.

Waiting for a few seconds, let devices go into working condition.

2, Select Bluetooth input  option by remote control, white indicator light will turn on and flash. Or please make sure if Bluetooth connect with M25. And shut off other Bluetooth device.

peachtree

M25 ACTIVE MONITORS

- 3, Please use your Bluetooth device search new Bluetooth device ,if get “M25”, connection it.if need pairing code, entry “1234” or “0000”.
- 4, If pairing successfully, white light “always on”, pairing finished .
- 5, The same Bluetooth device work again ,no need pairing one more time, M25 will auto connect with the device pairing last time .

Operation Bluetooth function

- 1, Connect your Bluetooth device as above ways.
- 2, Select Bluetooth input mode by remote control ,and you also can press volume knob, and choose Bluetooth input mode .If it on Bluetooth input mode ,white light will on .
- 3, if your Bluetooth device support AVRCP agreement, you can use your remote control to select “PLAY/PAUSE /PREV / NEXT” .

USB charge

The back panel USB plug is made to charge your electronic device (smartphone, MP3 player).

Note : no sound will be sent to the speaker trough this USB plug.

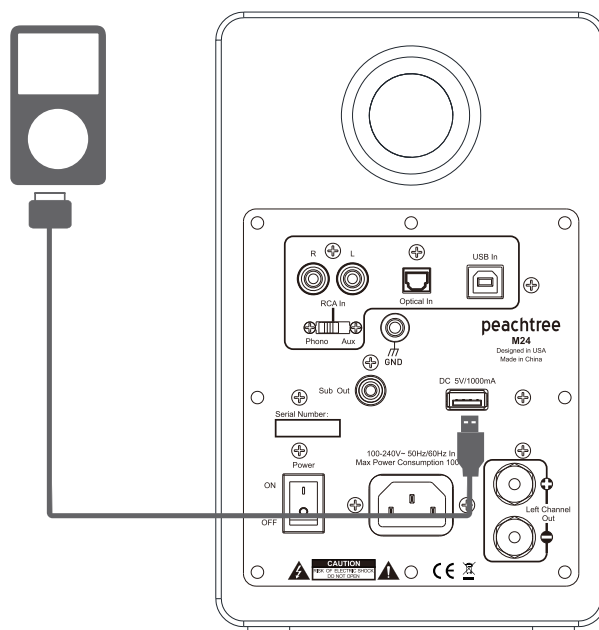

peachtree

M25 ACTIVE MONITORS

PHONO

(For use with a turntable without built-in phono pre-amp):

Slide the Phono / Line switch to phono position.

Connect the RCA L/R from your turntable to the RCA L/R inputs on the rear panel of the Peachtree M25.

Connect the ground wire from the turntable to the GND on the rear panel of the Peachtree M25.

Press RCA on the Peachtree M25 remote.

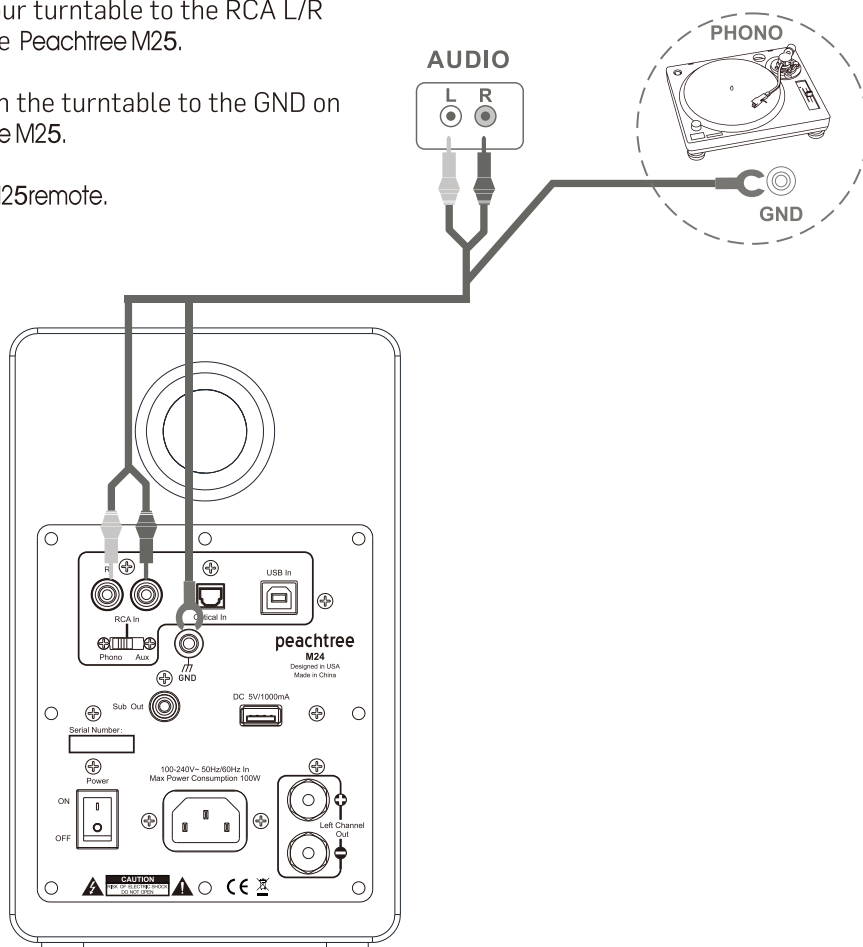

peachtree

M25 ACTIVE MONITORS

Connect TV, DVD, console, PC

A

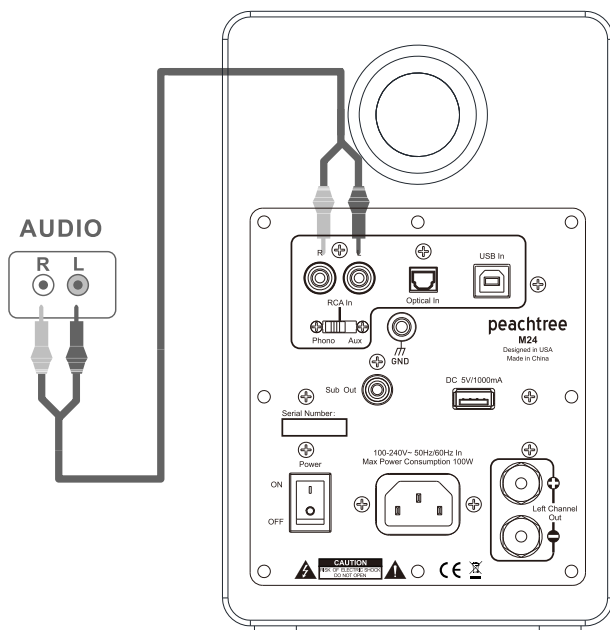

B

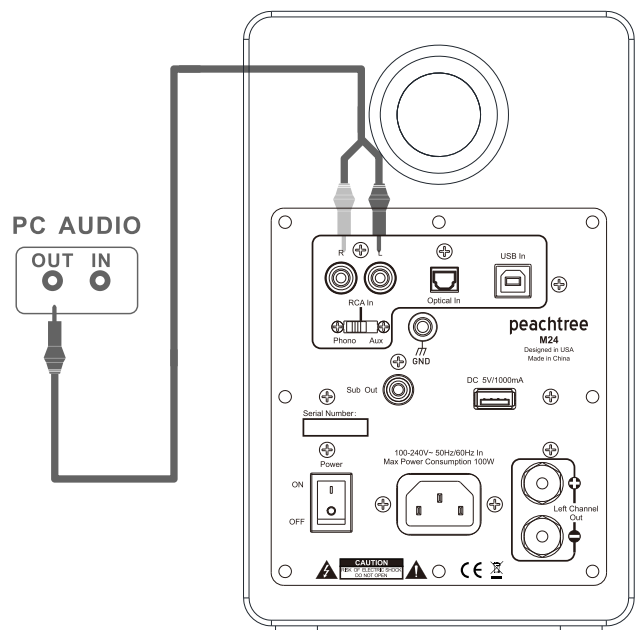

CONFIGURATION A(TV,DVD,CD-RCA stereo plugs):

Connect the RCA L/R to your TV,DVD etc.and the RCA L/R to the Stereo Input on rear panel of the M25.

Note that most newer TV remotes can control the M25 active speaker volume if connected to variable TV audio out.

CONFIGURATION B(PC):

Connect the mini jack to your PC and the RCA L/R to the Stereo Input on rear panel of the M25.

peachtree

M25 ACTIVE MONITORS

Limited Warranty

Dear Customer,

This product has been designed and manufactured to the highest quality standards, however if something goes wrong with this product, and the country distributor warrants free replacement parts or repair by the official distributor.

This limited warranty is valid for the original owner for a period of two years from the date of purchase, it is not transferable.

What is covered by the limited warranty :

The limited warranty covers all production and material defects of the product, except for the damages stated below.

What is not covered by the limited warranty :

Damages caused by packing and transport

Defects caused by accidents, misuse, normal wear and tear, mis-maintenance, voltage variation and overloading.

Damages caused by incorrect installation or operation
Damages caused by modification or repair by a nonauthorised service centre and use of non-original spare parts

Other damages due to conditions beyond the supplier's control such as fire, rain, stroke of lightning, war and other force majeure events

How to claim parts or repair under warranty :

To have your product serviced under warranty, you must contact the dealer from where you bought the product.

You will need to produce this warranty booklet completed and stamped by your dealer on the date of purchase. Alternatively, you will need the original sales invoice or other proof of ownership and date of purchase.

The supplier is liable only to repair or replace defective parts of products and the supplier is not responsible for indirect losses or damages arising from the use of the product.

Transportation costs for servicing are not covered by the warranty.

A service repair or replacement cannot exceed the value of the product under warranty, in no event shall the supplier be responsible or liable for special, incidental, consequential or indirect damages.

Dealer name and stamp:

Date of purchase:

peachtree

M25 ACTIVE MONITORS

Specifications

Tweeter:	1 inch soft-dome
Woofers:	4 inch Aluminium cone
Nominal impedance:	4 Ohm
Sensitivity 2.83V(1W/1M):	85dB
Power Output:	40W x 2
Frequency Response:	60Hz-20KHz
Crossover System:	2-way
Amplifier Type:	Class D
Inputs:	1 x RCA&Phono, 1x Optical, 1xUSB, 1x Bluetooth
Outputs:	1xUSB(charge), 1xSub Woofer
Amplifier Input Sensitivity:	480mV(Line RCA)
Frequency Range:	20Hz-20KHZ @ +/- 3dB
THD (1W@1KHz):	<0.1%
Dimensions:	140mm x 190mm x 220mm
Net Weight:	5.7 Kg

FCC Statement

This equipment has been tested and found to comply with the limits for a Class B digital device, pursuant to part 15 of the FCC Rules. These limits are designed to provide reasonable protection against harmful interference in a residential installation. This equipment generates, uses and can radiate radio frequency energy and, if not installed and used in accordance with the instructions, may cause harmful interference to radio communications. However, there is no guarantee that interference will not occur in a particular installation. If this equipment does cause harmful interference to radio or television reception, which can be determined by turning the equipment off and on, the user is encouraged to try to correct the interference by one or more of the following measures:

- Reorient or relocate the receiving antenna.
- Increase the separation between the equipment and receiver.
- Connect the equipment into an outlet on a circuit different from that to which the receiver is connected.
- Consult the dealer or an experienced radio/TV technician for help.

Caution: Any changes or modifications to this device not explicitly approved by manufacturer could void your authority to operate this equipment.

This device complies with part 15 of the FCC Rules. Operation is subject to the following two conditions: (1) This device may not cause harmful interference, and (2) this device must accept any interference received, including interference that may cause undesired operation.

RF Exposure Information

The device has been evaluated to meet general RF exposure requirement. The device can be used in portable exposure condition without restriction.