



Siklu

MultiHaul™

Point to Multipoint Gigabit Ethernet Wireless Solution

Installation Manual



MH-INST-01, Issue 2

Jan 2017

Trademarks

Siklu, the Siklu logo, and MultiHaul are all trademarks of Siklu Communication Ltd.

All other product names and trademarks mentioned in this document are trademarks or registered trademarks of their respective companies.

Copyrights

Copyright © 2016 Siklu Communication Ltd. All rights reserved.

No part of this publication may be reproduced or distributed in any form or by any means, or stored in a database or retrieval system, without the prior written consent of Siklu.

Disclaimers

The information contained in this document is subject to change without notice.

Siklu assumes no responsibility for any errors that may appear. Siklu makes no warranties, expressed or implied, by operation of law or otherwise, relating to this document, the products or the computer software programs described herein.

This document was originally written in English. Please refer to the English language version for a full and accurate description of all products and services described herein.

About this Document

This document is the Installation Manual for the point-to-multipoint wireless Link.

It provides product overview and details the installation, setup and monitoring.

Note:



Features and functionality described in this document may be available for specific product models or starting from specific SW version.

Please review the individual product's release notes to verify if a specific feature is supported in the product you use.

Applicable Products and Releases

- V-Band Wigg-based
 - MultiHaul, minimum SW release 0.9.0

Audience

This document assumes a working knowledge of wireless backhaul platforms and their operating environments.

This document is intended for use by all persons who are involved in planning, installing, configuring, and using the MultiHaul system.

Conventions

The following conventions are used in this document in order to make locating, reading, and using information easier.

Special Attention

Hint:



Informs you of a helpful optional activity that may be performed at the current operating stage.

Note:



Provides important and useful information or describes an activity or situation that may or will interrupt normal operation of the MultiHaul system, one of its components, or the network.

Caution:



Describes an activity or situation that requires special attention or warning.

Text Conventions

Document References

Italicized text is used to reference sections or chapters in this document. In many cases, references use clickable hypertext links that enable immediate access to referenced objects.

Command Input

Monospace text is used to help delineate command line user input or text displayed in a command window.

Safety and Regulatory Notices

The following are mandatory notices for installation and operation of MultiHaul Wireless Backhaul Link. Indications appearing here are required by the designated government and regulatory agencies for purposes of safety and compliance.

General

Do not install or operate this System in the presence of flammable gases or fumes. Operating any electrical instrument in such an environment is a safety hazard.

European Commission

This product has been designed to comply with CE markings in accordance with the requirements of European Directive 1995/5/EC.

This product has been designed to comply with the requirements of European Directives.

This equipment must be permanently earthed for protection and functional purposes. To make a protective earth connection, use the grounding point located on the System ODU using a minimum amount of 16AWG grounding cable or according to local electrical code.

This apparatus is intended to be accessible only to authorized personnel. Failure to prevent access by unauthorized personnel will invalidate any approval given to this apparatus.

This product is in full compliance with the following standards:

- RF V-Band FCC Part 15.255
- Safety IEC 60950
- Operation EN 300 019-1-4 Class 4.1E
- Storage EN 300 019-1-1 Class 1.2
- Transportation EN 300 019-1-2 Class 2.2

FCC/IC Regulatory Statements

This equipment has been tested and found to comply with the limits for a Class B digital device, pursuant to Part 15 of the FCC Rules and IC RSS standards. These limits are designed to provide reasonable protection against harmful interference in a residential installation. This equipment generates uses and can radiate radio frequency energy and, if not installed and used in accordance with the instructions, may cause harmful interference to radio communications. However, there is no guarantee that interference will not occur in a particular installation. If this equipment does cause harmful interference to radio or television reception, which can be determined by turning the

equipment off and on, the user is encouraged to try to correct the interference by one or more of the following measures:

- Reorient or relocate the receiving antenna.
- Increase the separation between the equipment and receiver.
- Connect the equipment into an outlet on a circuit different from that to which the receiver is connected.
- Consult the dealer or an experienced radio/TV technician for help.

Note:



Changes or modifications to this equipment not expressly approved by Siklu LTD or the party responsible for compliance could void the user's authority to operate the equipment.

Caution:



Outdoor units and antennas should be installed **ONLY** by experienced installation professionals who are familiar with local building and safety codes and, wherever applicable, are licensed by the appropriate government regulatory authorities. Failure to do so may void the product warranty and may expose the end user or the service provider to legal and financial liabilities. Siklu LTD and its resellers or distributors are not liable for injury, damage or violation of regulations associated with the installation of outdoor units or antennas.

Prudence: Les unités extérieures et les antennes doivent être installés que par des professionnels expérimentés d'installation qui sont familiers avec les norms locales et les codes de sécurité et, si applicable, sont agréées par les autorités gouvernementales de réglementation compétents. Ne pas le faire peut annuler la garantie du produit et peuvent exposer l'utilisateur final ou le fournisseur de services d'obligations juridiques et financiers. Revendeurs ou distributeurs de ces équipements ne sont pas responsables des blessures, des dommages ou violation des règlements liés à l'installation des unités extérieures ou des antennes. L'installateur doit configurer le niveau de puissance de sortie des antennes conformément aux réglementations nationales et le type d'antenne.

TABLE OF CONTENTS

1	Introduction to the MultiHaul System	10
1.1	Functional Description	10
1.2	Technical Specifications.....	11
1.3	Management	12
2	Installing the MultiHaul System	13
2.1	Preparing the Site.....	14
2.1.1	Physical and Environmental Requirements.....	14
2.1.2	Cabling Requirements.....	15
2.2	MultiHaul Package Content.....	16
2.3	Unpacking the MultiHaul	16
2.4	Required Tools.....	16
2.5	Mounting the MultiHaul.....	17
2.6	Connecting the Cables.....	18
2.6.1	Power Options	18
2.6.2	Grounding the MultiHaul.....	19
2.6.3	Preparing the Cables	20
2.7	System LEDs	20
2.8	Link Up Verification	21
3	Setup and Monitoring Using the Command Line Interface	22
3.1	Establishing a CLI Session with the ODU	22
3.2	General Configuration Commands: Save, Reset, Rollback.....	23
3.3	Configuring and Displaying System Information Using the CLI	23
3.4	Configuring System IP Addresses Using the CLI.....	24
3.5	RF Settings and Provisioning	26
3.5.1	Base Unit Setup	26
3.5.2	Terminal Unit Setup	27
3.5.3	Remote Terminal Units Setup and Monitoring	28
3.6	Configuring Ethernet Interfaces Using the CLI.....	29
3.6.1	Displaying Interface Status	30
3.6.2	Configuring Interface Parameters.....	31
4	Ethernet Services Configuration and Monitoring	32
4.1	Default Bridge Configuration	32
4.2	Bridge Mode	32
4.3	Bridge Architecture.....	33

4.4 Services Configuration Overview 33

TABLE OF FIGURES

Figure 1-1 MultiHaul Functional Block Diagram 10

Figure 2-1 Mounting Bracket 17

Figure 2-2 Connection Panel Details 18

Figure 2-3 Grounding Scheme 19

Figure 2-4 All-Weather Connecting Cable Shell Assembly 20

Figure 3-1 Launching CLI..... 22

1 Introduction to the MultiHaul System

This chapter provides a brief overview of the MultiHaul product line.

Siklu MultiHaul™ is the culmination of innovation for point to multipoint carrier-class systems operating in the uncongested unlicensed V-band, delivering very high adaptive bandwidth. It features unique self-aligning antennas for quick installation and long reach operations, in an outdoor yet eye-pleasing industrial design.

1.1 Functional Description

The MultiHaul is P2MP system based on WiGig 802.11ad chipset. The key features of the system are:

- P2MP wireless connectivity in the un-licensed 60GHz band, for up to 8 stations
- Scanning antenna, to simplify the alignment process of the units
- P2P wireless connectivity in the un-licensed 60GHz band

There are two options for this system, functionally wise. A system can serve as an access point (“Base Unit” – BU) or as an end-point station (“Terminal Unit” – TU).

The RF Chip is connected to an array of 32-64 dipole antennas, depending on product version.

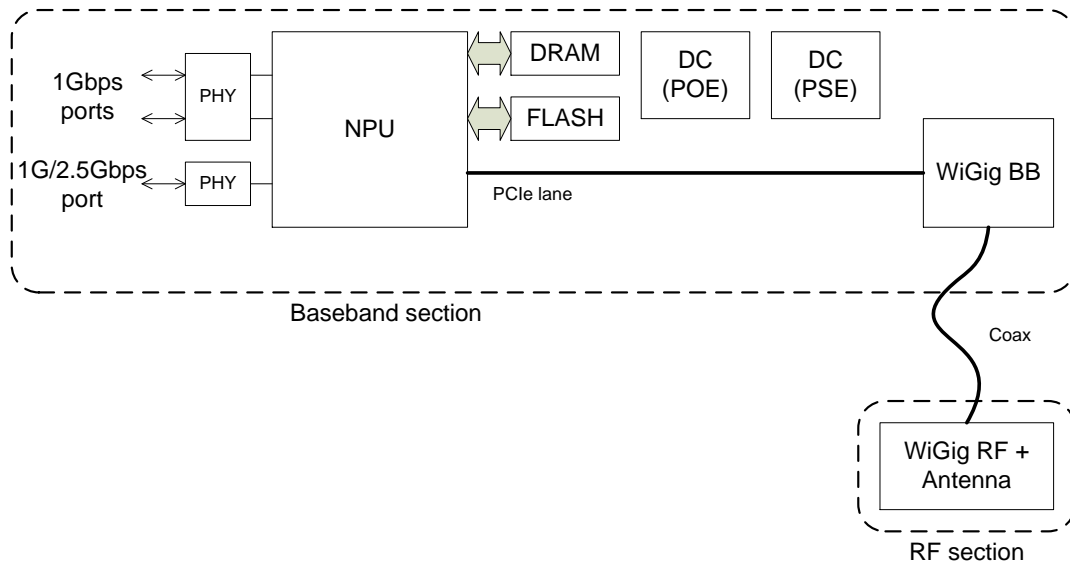

Figure 1-1 MultiHaul Functional Block Diagram

1.2 Technical Specifications

For detailed technical specifications please refer to the datasheet.

For detailed supported features list please refer to the product's release notes.

		MH-BU	MH-TU
Topologies	Point to Multi-point Point to Point	✓	✓
Built-in Antenna	Horizontal scanning: 90° Vertical beam-width: 20°	✓	✓
Frequency & Duplexing	57-64GHz	✓	✓
Channels	2160MHz wide, 3 non-overlapping channels	✓	✓
Modulation & Adaptive rate	10 level of hitless adaptive bandwidth, coding and modulation	✓	✓
Line Rate (Mbps) ⁽¹⁾	Line rate up to	3080	3080
System Gain (link budget)	125dB (including antenna)	✓	✓
Interfaces	3x GbE SFP supports 1GbE & 2.5GbE	2x RJ-45 1x SFP	Up to 3x RJ-45
Terminal Units (TU)	Up to 8 Terminal Units	✓	-
Ethernet Features	IEEE 802.1d transparent bridging VLAN & VLAN stacking Jumbo frames	✓	✓
Encryption	AES 128-bits	✓	✓
Management & Provisioning	Zero-touch turn up; In-band, out-of-band management Web GUI (one-click configuration of local and remote units) & Embedded CLI SNMPv2/3, TACACS+, RADIUS	✓	✓
Conformance	Radio: FCC Part 15.255 EMC: FCC 47CFR.part 15 Safety: UL 60950	✓	✓
Power Supply	PoE (IEEE 802.3af/at)+, 10W without PoE-Out, 50W with PoE-Out.	✓	✓
PoE-Out	ETH2: 26W, 802.3at ETH3: 13W, 802.3af	✓ (SFP)	✓ ✓
Environmental	Operating Temperature: -30÷+55°C	✓	✓

¹ Actual throughput varies with traffic patterns to/from the Terminal Units

	(optional -49° to +131°F) Ingress Protection Rating: IP65 (optional IP67)		
Dimensions (HxWxD)	11.4 x 5.2 x 3.5 in.	✓	✓
Weight	3 lbs. (including mounting kit)	✓	✓

1.3 Management

You can manage MultiHaul system using a Web-Based Element Management System (Web EMS) or a Command Line Interface (CLI). The CLI is compatible with SNMP.

Advanced network features must be managed using the CLI.

The MultiHaul system features a wide range of built-in indicators and diagnostic tools for advanced OAM functionality. The system is designed to enable quick evaluation, identification, and resolution of operating faults.

Note:



Web-Management GUI support depends on product SW version. If not available, CLI should be used for managing each end separately.

2 Installing the MultiHaul System

This chapter describes how to install and perform the installation of a MultiHaul outdoor unit (Base Unit or Terminal Unit), including:

- Preparing the Site
- MultiHaul Package Content
- Unpacking the MultiHaul
- Required Tools
- Mounting the MultiHaul
- Connecting the Cables
- System LEDs
- Link Up Verification

The installation of the MultiHaul system is followed by initial system setup that will be described in the next chapter.

The installation and maintenance of the MultiHaul link should only be done by service personnel who are properly trained and certified to carry out such activities.

L'installation et l'entretien de la liaison MultiHaul ne doivent être effectués par du personnel de service qui sont formés et accrédités pour mener à bien ces activités.

Caution:



It is the responsibility of the installer to insure that when using the outdoor antenna kits in the United States (or where FCC rules apply), only those antennas certified with the product are used. The use of any antenna other than those certified with the product is expressly forbidden in accordance to FCC rules CFR47 part 15.204.

Avvertissement:

Il est de la responsabilité de l'installateur de s'assurer que lorsque vous utilisez les kits d'antennes extérieures, seules les antennes certifiées avec le produit sont utilisés. L'utilisation d'une antenne autre que ceux qui sont certifiés avec le produit est expressément interdite par la réglementation FCC partie 47 CFR 15.204 et IC normes RSS.

Minimum safe distance from antenna while radiating is 30cm (according to calculation done based on "Environmental evaluation and exposure limit according to FCC CFR 47part 1, 1.1307, 1.1310; RSS-102, Safety Code6).

Distance de sécurité minimum de l'antenne tout en rayonnant est 30cm (selon le calcul fait sur la base de "l'évaluation environnementale et la limite d'exposition selon FCC CFR 47part 1, 1,1307, 1,1310, RSS-102, CODE6 sécurité).

2.1 Preparing the Site

Carefully select and prepare each MultiHaul ODU site to make device installation and configuration as simple and trouble-free as possible. During site selection and preparation, always consider the long-term needs of both your network and your applications.

2.1.1 Physical and Environmental Requirements

Each MultiHaul ODU site should adhere to the following requirements:

- There must be a clear, unobstructed line-of-sight between ODU.
- The MultiHaul ODU should be mounted on a fixed, stable, permanent structure. A reinforced steel mounting pole is required, with a diameter measuring from 2-4 inches (recommended). Note the radio can be mounted on poles from 1.5-12 inches using the provided steel worm-clamps.

Caution:



Do not mount the MultiHaul device on a structure that is temporary or easily moved. Doing so may result in poor service or equipment damage.

- You must mount the MultiHaul ODU in a site that is easily accessible to authorized personnel, and only authorized personnel.
- Operating temperature: between -45° and +55°C.
- Relative humidity: 0 to 100%.
- Maximum altitude: 4,500m.

2.1.2 Cabling Requirements

- Install the MultiHaul ODU where network connections and optional power cabling are ready for operation and easily accessible.
- All cabling connected to the ODU should be outdoor-grade, with UV protection.
- PoE input – Connect Ethernet cable to Eth1
- PSE Output – The voltage output at the PSE port is following the voltage at the PoE input port. The cable length from the PSE port (ETH#2) to the powered device (PD) should not exceed 40 meter, even if the PSE option is disabled.
- You should use shielded outdoor Cat5e cables terminated with metallic RJ45 connectors.
- In order to protect indoor equipment, you must install surge protection circuits on all copper cables on their entrance to the building.
- Install the MultiHaul ODU in a location where proper electrical outdoor grounding is readily available. Typically, the grounding connection is attached directly to the mounting pole. If not already present, then suitable structure-to-earth grounding connections must be created before installation. Ground the ODU using a minimum quantity of 16AWG grounding cable or according to local electrical code.

Caution:

Improper electrical grounding can result in excessive electromagnetic interference or electrical discharge.



Siklu will not be held responsible for any malfunction or damage in the event that the ODU is not properly grounded.

2.2 MultiHaul Package Content

MultiHaul link consists of a Base Unit (BU) and 1 to 8 Terminal Units (TU). The unit's mounting kit is included.

The MultiHaul packages include the following components:

Package	Description	Quantity
MultiHaul ODU		
	MultiHaul ODU (integrated antenna)	1
	Connecting cable All-Weather shells	3
	Unit grounding cable (90 cm)	1
	MultiHaul mounting assembly (attached to the ODU)	1
	Steel Worm Clamps	2

2.3 Unpacking the MultiHaul

The MultiHaul package content should be examined carefully before installation.

When you unpack the components of the MultiHaul, it is important to use care so as to avoid damaging or scratching the antenna radome.

2.4 Required Tools

Ensure that you have the following tools with you when performing a MultiHaul installation:

- Philips screwdriver, medium size head
- Flat-head screwdriver, medium size (5mm) head
- 7mm Hex socket driver
- Standard open-end wrench, 13 millimeter for the ports' caps
- Cable ties (for securing network and optional power cables)
- Cutter
- Cable labeling

2.5 Mounting the MultiHaul

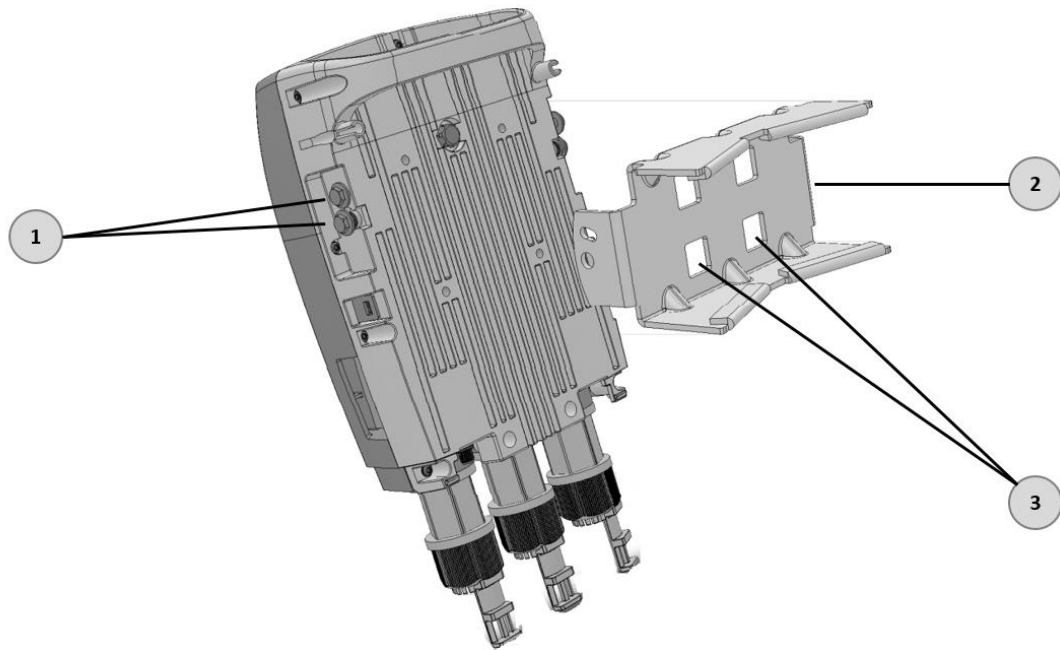

1. Elevation Lock Bolts (2 additional bolts at opposite side of the ODU)
2. Mounting Kit
3. Worm Clamp fixing points

Figure 2-1 Mounting Bracket

1. Mount the ODU and the Mounting Bracket on a fixed reinforced steel mounting pole with 2-4 inches diameter.
2. Use worm clamps (steel bands) to secure the bracket to the mounting pole.
3. In order to allow free movement when pointing the antenna, unlock the Elevation Lock Bolts.
4. Verify visually that the ODU is pointing to remote site. Optimize the Azimuth alignment by turning the mounting bracket (make sure the worm clamps are not tightened) and change the Elevation alignment by moving the ODU up and down.
5. Once optimum achieved, fasten the worm-clamp to secure the bracket to the mounting pole and tighten the Elevation Lock Bolts.

Alignment is now completed. The system's scanning antenna will automatically align the beam for optimal performance.

2.6 Connecting the Cables

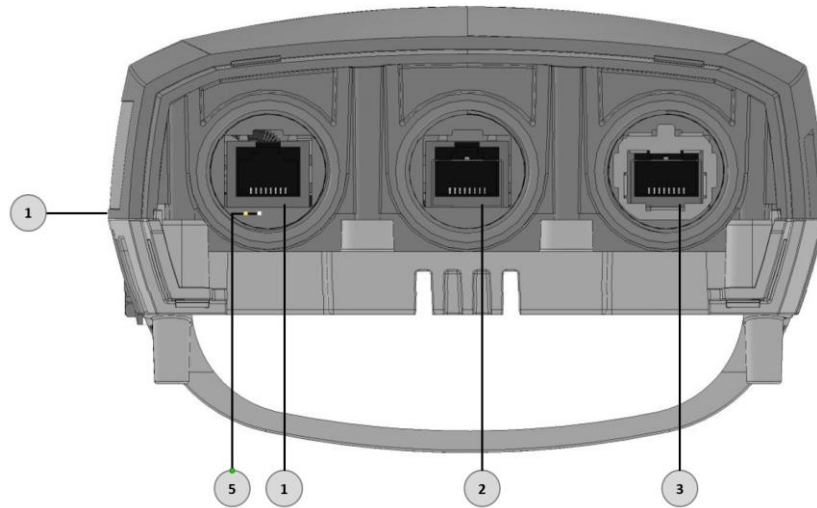

- 1. Electrical Ground Point(GND)
- 2. Ethernet RJ45 Eth#1 (PoE in)
- 3. Ethernet RJ45 Eth#2 (PoE Out)

- 4. Ethernet SFP Eth#3
- 5. Reboot push-button. Restore Factory Default (is pushed for more than 8 seconds)

Figure 2-2 Connection Panel Details

2.6.1 Power Options

To power up the MultiHaul using PoE, connect the cable to Eth#1.

You may use direct DC (input range: 36÷57Vdc) by using an RJ45-DC Adapter (can be obtained from Siklu). In this case, port ETH#1 will be used for power only.

2.6.2 Grounding the MultiHaul

1. Connect one end of the grounding cable to the ground outlet on the left side of the ODU using the grounding cable lug.
2. Tighten the lug securely in place.
3. Connect the opposite end of the grounding cable to the earth connection, typically located on the mounting pole. If the earth connection is out of reach of the grounding cable, install an alternative cable.

To make a protective earth connection, use the grounding point located on the System ODU using a minimum amount of 16AWG grounding cable or according to local electrical code.

It is recommended to use Lightning Surge Protector on every Ethernet cable to protect the indoor networking equipment. The Lightning Surge Arrestor should be installed indoor next to the cable's point-of-entry and should be properly grounded.

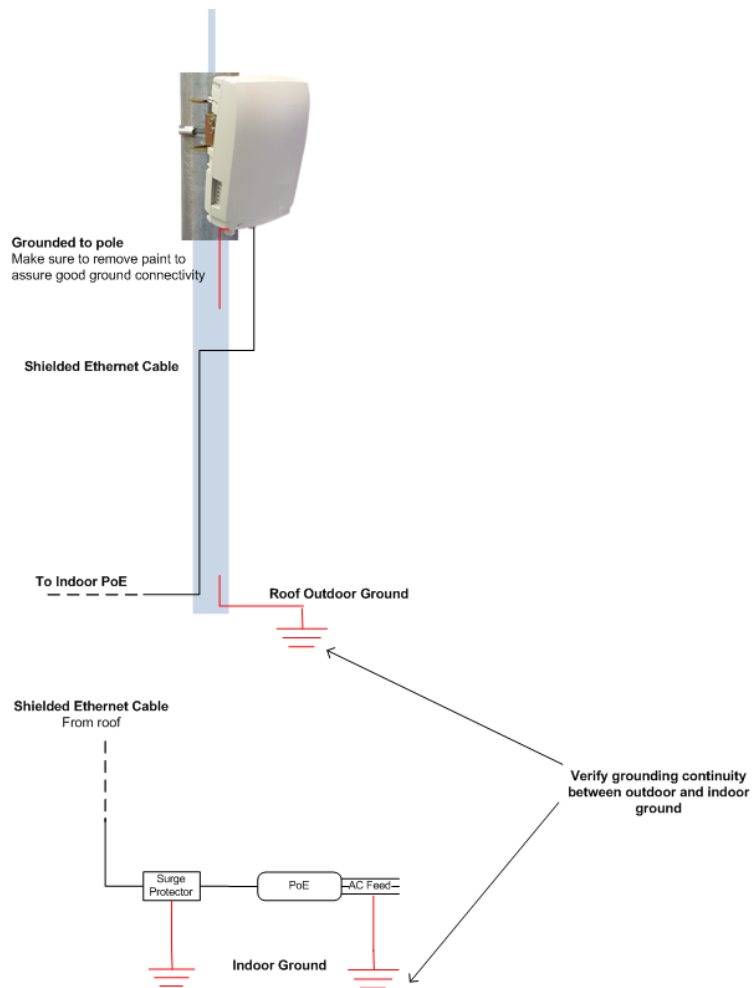

Figure 2-3 Grounding Scheme

2.6.3 Preparing the Cables

Before inserting a cable connector into the ODU, you must first enclose the cable connector in a protective All-Weather shell. Three sets of All-Weather shells are provided with the ODU for the ODU interfaces.



Figure 2-4 All-Weather Connecting Cable Shell Assembly

The provided protective All-Weather Shells fit cables from 3.5mm to 9.0mm diameter.

1. Thread the cable and tight the shell to the ODU firmly by hand (do not use tools).
2. Insert the rubber gasket snugly and tight the connector lock.

Caution:



To avoid accidental damage to the connector, when removing the All-Weather Shell, unlock the gland first.

2.7 System LEDs

LED	Color	Description
PWR (Power)	Green – Power ON	Blink Green – booting up
	Orange – Booting up (2 seconds)	Boot failure if continues)
	Red – Power Failure	
	Off – No Power	
RF	Green – At least one station associated	Device under association, no station yet associated
	Off – Link Down	
ETH1/2/3:	Green – Link 1G	
	Orange – Link 10/100	
	Off – No Link (Carrier)	
BT		For future use

2.8 Link Up Verification

1. Verify that RF LED is green, indicating association with at least one station.

The MultiHaul link can now pass traffic and management between the ports and over the radio link.

Use the Command Line Interface for radio link configuration and monitoring.

3 Setup and Monitoring Using the Command Line Interface

This chapter explains how to perform basic configuration tasks using the CLI.

3.1 Establishing a CLI Session with the ODU

1. Launch standard SSH client. You can use any common, open source SSH client program, such as PuTTY, available for download from the web.

Open an SSH session to the system's IP address. The system's default IP address is **192.168.0.1**.

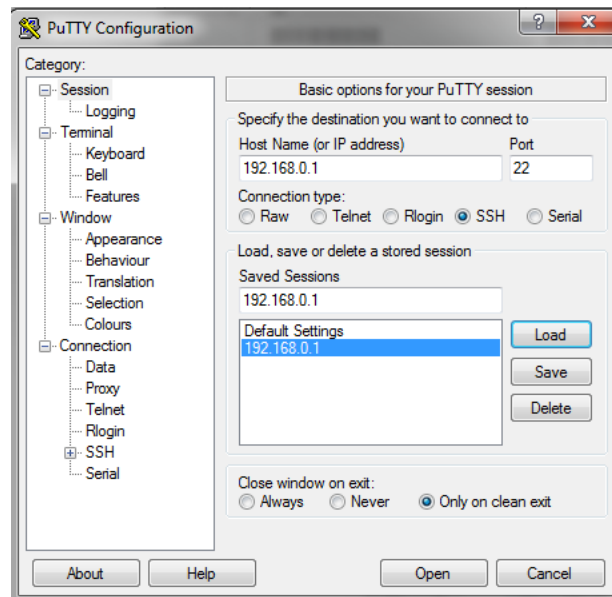

Figure 3-1 Launching CLI

2. PuTTY configuration (Recommended):
 - a. Go to category: Terminal -> Keyboard
 - Set Backspace key = Control-H
 - Set The function keys and keypad = Linux
 - b. Go to category: Window
 - Set Lines of Scrollback = 100000
 - c. Save the session and configuration. Give it a name and Click **Save**. The session will be stored under the Saved Sessions.
3. When prompted, enter the username and password. Default: **admin** and **admin**.

```
login as: admin
```

```
MH, S/N: F626500012, Ver: 0.9.0 64311
```

```
admin@192.168.0.15's password:
```

3.2 General Configuration Commands: Save, Reset, Rollback

Whenever you make changes to the ODU configuration, you must save the configuration changes to the startup configuration. If you do not save the configuration, the changes will be lost the next time the system is reset. Use the following command to save configuration changes to the startup configuration:

```
Local_Site> copy running-configuration startup-configuration
```

To reset the system, use the `reset system` command. You must reset the system whenever you exit Alignment mode.

```
Local_Site> reset system
```

Rollback is a safety measure that allows recovering from system configuration changes that caused loss of communication.

When Rollback is used, a timer runs (and restarts) whenever command is entered. In the event that no command is entered within the timeout period, the system automatically reboots and comes up with the saved startup configuration.

A Rollback timeout is especially recommended when configuring remote elements that are being managed over the link.

To specify the Rollback timeout period, use the following command:

```
set rollback timeout <duration-in-seconds>
```

3.3 Configuring and Displaying System Information Using the CLI

Use the `show system` command to display basic information about the ODU.

```
Local_Site>show system
```

```
system description           : MultiHaul
system snmpid                : .1.3.6.1.4.1.31926
system uptime                : 0000:04:51:32
system contact               : undefined
system name                  : BU
system location              : undefined
system voltage               : 45 poe
system temperature           : 34
system date                  : 2016.01.12
system time                  : 21:37:18
system cli-timeout           : 15
system loop-permission       : enabled
system bridge-mode           : transparent
```

- Description – model description (R/O).

- SnmpID – SNMP ID for Siklu products (R/O).
- System Uptime – R/O field. Time elapsed from last power on.
- Contact – text string.
- Name – text string. Enter a unique name to identify your system.
- Location – text string.
- Voltage – input voltage and indication DC or PoE (R/O).
- Temperature – system temperature in C° (R/O).
- Date & Time – Date [YYYY.MM.DD], Time [HH:MM:SS]
- Cli-timeout – timeout for auto-logout.
- Loopback-permission – controls the permission to perform system loopbacks
 - Enabled (default): all loops allowed.
 - Disabled: no loops allowed.
 - MAC-SWAP: only loops with MAC-SWAP allowed.
- Bridge-mode – system's supported bridge modes:
 - Transparent – forward all traffic to all ports.
 - Out of band – carry management traffic from a specified port only.

Use the **set system name** command to set the ODU's name. Once you set the ODU's name, a prompt appears with the name you just set, the date, and the time.

```
Default> set system name Local_Site
Local_Site>
```

To set system date & time, use the following command:

```
Local_Site> set system date 2016.01.12 time 15:08:00
```

3.4 Configuring System IP Addresses Using the CLI

The MultiHaul ODU supports up to four IP addresses that can be on different subnets and associated with different VLANs. You can assign a static route to each IP address. The Default IP-Gateway is defined as a static route.

By default, one IP address is defined (IP #1):

- IP Address – 192.168.0.1
- IP network Prefix – 24
- VLAN – 0 (not defined)
- Default Gateway – 0.0.0.0 (by default, no route is defined).

Use the **set ip** command to change or add an IP address. The command must be followed by the index number of the IP address you want to add or change. Use the index number 1 to change the default IP address. For example:

```
set ip <ip-index> ip-addr <value> [prefix-len <value>] [vlan
<value>]
      <ip-index>                : integer 1..4
```

```
Local_Site>set ip 1 ip-addr 192.168.0.11 prefix-len 24
```

If the IP entry does not already exist, the **set ip** command creates it and assigns the attributes specified. If the interface address or the default router address is not explicitly specified, the entry is created with the default value that has been defined for the VLAN.

If the IP entry already exists, the **set ip** command replaces the attributes that are currently defined for the entry with the values specified in the command.

Up to four IP addresses can be specified on the command line.

A **set ip** command fails if the route specified is not within the subnet that has been defined by mask.

Note: If you change the default IP address, your connection to the ODU will be lost. To re-establish a connection, launch an Internet browser and connect using the new IP address.



To display all of the currently configured IP addresses and their attributes, use the **show ip** command:

For example:

```
Local_Site>show ip
```

```
ip 1 ip-addr           : 192.168.0.11
ip 1 prefix-len       : 24
ip 1 vlan             : 0
ip 1 default-gateway  : 0.0.0.0
```

To delete IP entries, use the **clear ip** command:

```
clear ip <index>
```

To create and modify an IP Route and Default Gateway, use the **set route** command:

```
set route <idx> [dest <ip-address>] [prefix-len 0..32] [next-hop
<ip-address>]
```

idx number 1 to 10

dest ip address in the form X.X.X.X where X is a decimal number from 0 to 255 (for example, 10.0.15.74).

next-hop ip address in the form X.X.X.X where X is a decimal number from 0 to 255 (for example, 10.0.15.74). All IP addresses in the table must be different.

prefix-len ip prefix – a number from 0 to 32

By default, no route is defined.

To set a static route, use the following command:

```
Local_Site>set route 1 dest 192.168.0.64 prefix-len 30 next-hop
192.168.0.66
```

To set a single default gateway, use the following command. When single IP is used and a Static route is not used, you may configure a default IP gateway. In such case, use 0.0.0.0 as the destination network with **prefix-len 0**.

```
set route 1 dest 0.0.0.0 prefix-len 0 next-hop 192.168.0.254
```

To display all of the currently configured routes and their attributes, use the **show route** command:

```
Local_Site>show route
ip 1 dest      : 0.0.0.0
ip 1 prefix-len: 0
ip 1 next-hop  : 192.168.0.254
```

3.5 RF Settings and Provisioning

3.5.1 Base Unit Setup

Use the **show base-unit** command, to display the RF settings of the Base-Unit.

Use the **set base-unit** command, to set the RF settings of the Base-Unit.

```
BU> show base-unit
```

```
base-unit ssid           : siklu
base-unit password       : siklu
base-unit frequency      : channel-2
base-unit ssid-visible   : enable
base-unit guest-connection : enable
```

- SSID – Service Set Identifier (SSID) of the access point (base-unit). Default: siklu.
- Password – base-unit password used for connection. Default: siklu.
- Frequency – the channel frequency the BU is transmitting on. Default: channel-2.

- SSID-visible – determines if the BU will broadcast openly its SSID. Default: Enable.
- Guest-connection – determines if guest (unmanaged) terminals can be associated with the base unit. If guest-connection is enabled, any TU with the correct SSID and password can connect to the BU.

3.5.2 Terminal Unit Setup

Use the `show terminal-unit` command, to display the RF settings of the Terminal-Unit.

Use the `set terminal-unit` command, to set the RF settings of the Terminal-Unit.

```
TU1> show terminal-unit
```

```
terminal-unit ssid           : siklu
terminal-unit password       : siklu
terminal-unit connection-mode : auto-connect
terminal-unit status         : connected
terminal-unit frequency      : channel-2
terminal-unit tx-mcs          : 6
terminal-unit signal-quality  : 70
terminal-unit tx-throughput   : 401
terminal-unit rx-throughput   : 503
```

- SSID – Service Set Identifier (SSID) of the Terminal Unit that is used for connection with the Base Unit. Default: siklu.
- Password – base-unit password used for connection. Default: siklu.
- Connection-mode – auto connect or scan-only. Default: auto-connect.
 - Auto connect – TU will connect automatically to BU in case SSID/password match.
 - Scan only – TU will scan and present all visible BUs (without connecting to any of them, even if SSID/password match).
- Status (R/O) – connection status: connected (in case of association to a BU) or scanning (if not associated to a BU).
- Frequency (R/O) – the channel frequency the TU is locked on (determined by the BU).
- Tx-mcs – the WiGig Modulation & Coding Scheme (MCS) which is used to transmit the packets. MCS values: 1 to 10. MCS 0 is used top carry control messages.

- Signal-quality – the signal’s quality indication. Values: 0 to 100.
- Tx-throughput – the transmitted throughput over the RF interface (in Mbps).
- Rx-throughput – the received throughput over the RF interface (in Mbps).

Note:

Tx-mcs and signal-quality will present its value only in case of traffic. When no packets transmitted/received, value will be 0.

3.5.3 Remote Terminal Units Setup and Monitoring

From the Base Unit you can provision the connected Terminal Units.

Use the `show remote-terminal-unit` command, to display the RF settings of the connected TUs (1 to 8) and their settings.

Use the `set remote-terminal-unit` command, to set the RF settings of the connected TUs.

```
BU> show remote-terminal-unit
```

```
remote-terminal-unit 1 eth-port           : eth-tu1
remote-terminal-unit 1 mac                 : 00:24:a4:07:5d:0c
remote-terminal-unit 1 name                : undefined
remote-terminal-unit 1 status              : connected
remote-terminal-unit 1 association         : guest
remote-terminal-unit 1 tx-mcs              : 6
remote-terminal-unit 1 signal-quality      : 75
remote-terminal-unit 1 tx-throughput      : 501
remote-terminal-unit 1 rx-throughput      : 402
```

- Eth-port – name of the RF port that is used to connect to the TU.
- Mac – MAC address of the remote TU.
- Name – text string. Set the name of the remote TU. Default: undefined.
- Association – guest or managed.
 - Guest – TUs that are connected as ‘guest’ do not require setting on the BU side. An RF port will be created in case TU is connected. No services configuration is supported for ‘guest’ TUs (transparent bridge only).
 - Managed – TUs that are set to ‘managed’ reserve their RF port settings and will allow settings of services.

Note: TUs connected as 'guests' will be displayed only in case they are connected.



TUs connected as 'managed' will be displayed even if they are down.

- Tx-mcs – the WiGig Modulation & Coding Scheme (MCS) which is used to transmit the packets. MCS values: 1 to 10. MCS 0 is used to carry control messages.
- Signal-quality – the signal's quality indication. Values: 0 to 100.
- Tx-throughput – the transmitted throughput over the RF interface (in Mbps).
- Rx-throughput – the received throughput over the RF interface (in Mbps).

Note:

Tx-mcs and signal-quality will present its value only in case of traffic. When no packets transmitted/received, value will be 0.



3.6 Configuring Ethernet Interfaces Using the CLI

The MultiHaul system has up to four fixed Ethernet interfaces:

- **Host** – Management interface
- **Eth1** – ODU interface, port 1
- **Eth2** – ODU interface, port 2
- **Eth3** – ODU interface, port 3

On Base Units, RF interfaces are created when remote TUs are connected or set.

The Ethernet RF interfaces are named Eth-tu1, Eth-tu2...Eth-tu8.

On a Terminal Unit, RF interface is available. The Ethernet RF interface is named Eth-bu1.

You can change the default values of the ODU interfaces, and display the port status of a specific interface.

3.6.1 Displaying Interface Status

Use the `show eth` command, followed by the name of the interface, to display the Ethernet port status for a specific interface.

The following is an example of an Ethernet interface (Eth1) status display.

```
Local_Site> show eth eth1
```

```
eth eth1 description      : Eth 1
eth eth1 mtu              : 16384
eth eth1 mac-addr        : 00:24:a4:07:47:11
eth eth1 admin           : up
eth eth1 operational     : up
eth eth1 last-change     : 0000:00:13:17
eth eth1 name            : Eth1
eth eth1 alias           :
eth eth1 eth-type        : 1000fd
eth eth1 eth-act-type    : 1000fd
eth eth1 auto-neg        : enabled
eth eth1 loopback-mode   : disabled
eth eth1 loopback-timeout : 60
eth eth1 connector-type  : rj45
eth eth1 network-type    : customer-nni
```

- MTU – R/O field to indicate the Maximum Transmission Unit of the port.
- Mac-addr – MAC address of the port.
- Admin – port enable/disable.
- Operational – port up/down status.
- Last-change – time elapsed since last port status changed.
- Name – text field.
- Alias – text field.
- Eth-type – configured Speed/Duplex: speed (10/100/1000) and duplex (half/full) setting.
 - When Auto Negotiation Disabled – manual configuration of the speed and duplex (for RJ45 ports: 10HD, 10FD, 100HD, 100FD, 1000HD or 1000FD; for SFP ports: 1000XHD or 1000XFD).
- Eth-act-type – actual Speed/Duplex negotiated (if Auto-Neg enabled).
- Auto-neg – Auto negotiation enable/disable.

- Loopback-mode – enable and configure loopback on the port. External (towards the line side) or Internal (towards the radio side) loopback are available, with or without MAC addresses swap.
- Loopback Timeout – in seconds. Loopback will clear when timeout expires.
- Connector-type – RJ45 or SFP based on the physical port.
- Network-type – bridge port settings: customer-nni (transparent bridge), customer-uni (C-Vlans settings) or provider-nni (S-Vlan settings).

3.6.2 Configuring Interface Parameters

Use the `set eth` command, followed by the name of the interface to change the default values of an Ethernet interface.

For example, use the following command to set Ethernet port 1 to SFP mode:

```
set eth eth1 eth-type 1000xfd
```

4 Ethernet Services Configuration and Monitoring

The Ethernet services (VLAN) parameters and monitoring can be configured for managed terminals.

This chapter includes the following topics:

- Default Bridge Configuration
- Bridge Mode
- Bridge Architecture
- Services Setup
 - VLANs
 - Port Network Type
 - Bridge-Port (PVID)

4.1 Default Bridge Configuration

The default system's configuration is IEEE 802.1d Transparent Bridge. In this mode, all traffic (both tagged and untagged) and management is transparently forwarded between all ports and over the radio interfaces to all Terminal Units.

In addition, management VLAN can be used for out-of-band and in-band management.

Note: Services cannot be configured on Terminal Units configured with Association=guest. Only transparent bridge is supported.



Configure your Terminal Unit with Association=managed in case you wish to configure services.

4.2 Bridge Mode

Bridge mode is used in order to minimize config by users when implementing common networking scenarios.

Transparent – IEEE 802.1d Transparent Bridge. In this mode, all traffic (both tagged and untagged) is transparently forwarded between all ports and over the radio.

Out Of Band – allows local management only over the selected port. No management information will be carried over the radio or to other ports.

Note that as no management over the radio, the Web-GUI communication channel will be down, hence no management of the remote will be available.

Setting bridge mode:

```
set system bridge-mode
{transparent | {out-of-band <management-eth-port>}}
```

4.3 Bridge Architecture

The EtherHaul incorporates a fully functional integrated Provider Bridge (IEEE 802.1ad).

Provider Bridge, commonly known as Q in Q, extends the IEEE 802.1Q standard by providing for a second stack of VLANs in a bridged network. The general purpose of Provider Bridge is to enable frames from multiple customers to be forwarded (or tunneled) through another topology (provider network) using Service VLANs (S-VLAN).

The provider bridge, which may consist of multiple devices in the service provider domain, looks like a simple bridge port to the customer's traffic and maintains the Customer's VLANs (C-VLAN).

The implementation of Provider Bridge is a network of multiple virtual bridges connected in a "cross-like" fashion. Each component acts as a virtual bridge. A component can have both external and internal ports. An external port name is identical to its interface name. An internal port name uses the name of its peer component.

Bridge component types:

- S-type Component – an S component handles traffic tagged with S-VLANs.

A single S component (named S1) is the heart of the bridge and cannot be deleted. All packets passing through this bridge must be tagged with S-VLAN.

- C-Component – a C component handles traffic tagged with C-VLANs.

By default, no C components defined ("Single Component Bridge Model").

4.4 Services Configuration Overview

Configuring Ethernet services consists of 3 parts:

- VLAN configuration

Allow, block or add specific VLAN IDs on the system's ports.

- Port Network Type

Each Ethernet port can be configured to one of the following Network Types to support forwarding of C-VLANs and S-VLANs:

- Provider NNI (PNP - Provider Network Port) – port that doesn't have a C component associated with it and is used for S-VLANs processing.

S-VLAN entering the provider-nni port will be processed based on the VLAN configuration of the port.

Untagged or C-VLAN entering a provider-nni port will be considered as untagged (as they have no S-VLANs) and will be tagged internally using S-VLAN PVID (default is S-VLAN ID 1).

- Customer UNI (CEP - Customer Edge Port): port that has a C component associated with it and is used for C-VLANs processing.

C-VLAN entering a customer-uni port will be processed based on the VLAN configuration on the ports.

Untagged or S-VLAN entering a customer-uni port will be considered as untagged (as they have no C-VLANs) and will be tagged internally using C-VLAN PVID (default is C-VLAN ID 1).

- Customer NNI (CNP - Customer Network Port): port that doesn't have a C component associated with it but presents a simplified model for C-VLANs processing and transparent bridge implementation.

As in provider-nni, untagged or C-VLAN entering a customer-nni port will be considered as untagged (as they have no S-VLANs) and will be tagged internally using S-VLAN PVID (default is S-VLAN ID 1).

Processing of specific C-VLANs is done by mapping them to specific S-VLAN IDs using C-VLANs Registration.

By default, all Ethernet ports are configured as Customer NNI ports. That means all untagged and C-VLANs are carried transparently to all ports.

- Bridge-Port (PVID)

A VLAN ID which will be assigned to an untagged frame or a priority-tagged frame, (the VID is set to 0 indicating that the frame does not belong to any VLAN and only PCP field is relevant), which enters to the bridge through this port. The special value "undef" cannot be used as PVID.

- The default PVID is 1 with priority 0:
- Untagged frame entering the S1 component (or provider-nni) will be tagged with S-VLAN ID 1.
- Untagged frame entering a C component (or customer-uni) will be tagged with C-VLAN ID 1.