



# SX-200

## User's Manual

Section 1 – Product Overview .....	7
Introduction .....	7
Package Contents.....	7
About This User's Guide.....	8
Windows™ System Requirements.....	8
Other Operating System Requirements .....	8
Wireless Print Server Requirements .....	9
Print Server Components.....	10
LED Indicators .....	11
Pushbutton Functions.....	12
Factory Default Settings .....	12
Default Settings (wired and wireless print servers) .....	12
Wireless Default Settings (wireless print servers only).....	12
Section 2 – Hardware Installation.....	13
Before You Begin.....	13
Hardware Installation (wired and wireless versions).....	13
Verifying the Connection to the Printer.....	15
Section 3 – Configuration and Management .....	16
Configuration Options .....	16
ExtendView Utility.....	16
Web Browser Interface.....	16
HP Web JetAdmin Utility.....	17
Configuration Console.....	17
Configuring the Print Server via an Ethernet Connection .....	18
First-Time Configuration of the Wireless Print Server Using 802.11b or 802.11g (wireless print servers only).....	20
Windows Print Queue Configuration .....	21
Macintosh Print Queue Configuration.....	22
Configuring to Print Using TCP/IP (OS 10.x).....	23
Section 4 – Troubleshooting.....	24
Introduction .....	24
Printing Problems .....	24
Checking the Interface between the Print Server and the Printer: .....	24
Checking the Network Connection and Cabling: .....	25
Troubleshooting Windows Problems.....	25
Troubleshooting Network Configuration Problems.....	26
Troubleshooting Wireless Configuration Problems.....	27
Section 5 – Where to Get Help .....	28
Returning Products .....	29
Appendix A – Safety and Regulatory Notices.....	30
Information for United States Users .....	30
Declaration of Conformity (FCC).....	31
Information for Canadian Users (IC notice) .....	31
Information for European Users .....	32
Declaration of Conformity (CE).....	32
Appendix B – Updating Firmware .....	33
Loading New Firmware (Using the TCP/IP Update Utility) .....	33
Loading New Firmware (Macintosh OS-X) .....	36
Command console access information .....	37
Telnet Command Console Access .....	37
Serial Port Command Console Access .....	37
Network Commands.....	37
SH NW .....	37
SET NW AUTHtype .....	38
SH NW AUTH .....	38
SET NW CHannel .....	38
SET NW ENC .....	38
SH NW ENC .....	38
SET NW KEY# .....	38
SET NW KEYVAL.....	39

SET NW MDe .....	39
SET NW RAdio.....	39
SH NW MODE.....	39
SH NW RADio.....	39
SET NW SPeed .....	39
SH NW SPEED .....	39
SET NW SSid.....	39
CL NW SSid.....	40
SET NW BSsid.....	40
CL NW BSsid.....	40
SET NW RTS .....	40
SH NW RTS.....	40
SET NW APDEN .....	40
SH NW APDEN .....	40
SH NW STATS .....	41
SET NW CERTCN.....	41
SH NW CERTCN.....	41
SET NW CERTCN2.....	41
SH NW CERTCN2.....	42
SET NW CERTEXP.....	42
SH NW CERTEXP.....	42
SET NW CERTKEY .....	42
SET NW ID .....	42
SH NW ID .....	42
SET NW PW .....	43
SET NW INAP .....	43
SH NW INAP .....	43
SET NW REALM .....	43
SH NW REALM .....	43
SET NW WPAAUTO .....	43
SH NW WPAAUTO .....	44
SET NW WPAGROUP .....	44
SH NW WPAGROUP .....	44
SET NW WPAPSK .....	44
SET NW WPATRACE .....	44
SET NW IROAM.....	44
SH NW IROAM NW IROAM .....	45
SET NW DFS .....	45
SH NW DFS.....	45
SET NW REGDOMain .....	45
SH NW REGDOMain .....	46
SET NW WIRED .....	46
Port Commands .....	46
Serial Port Commands .....	46
SH PORT.....	46
SET PORT .....	47
CLEAR PORT S1 JOB.....	47
SET PORT S1 FLOW .....	47
SET PORT S1 PARITY .....	47
SET PORT S1 SIZE .....	47
SET PORT S1 SPeed.....	47
SET PORT S1 STOP .....	47
Parallel Port Commands .....	48
SH PORT.....	48
SET PORT.....	48
SET PORT P1 ACKH .....	48
SET PORT P1 BDir .....	48
SET PORT P1 ECP .....	48
SET PORT P1 FSTB .....	48

SET PORT P1 INWT .....	48
SET PORT P1 NBUF [ENable   DIsable] .....	49
SET PORT P1 NOINBUSY .....	49
SET PORT P1 POLL.....	49
SET PORT P1 PSTA .....	49
SET PORT P1 SOJBUSY .....	49
CL PORT <port> JOB.....	49
USB Port Commands.....	50
SET PORT U1 PSTA .....	50
SET PORT U1 NBUF [ENable   DIsable].....	50
Server Information Commands.....	50
SET SERVER DEscription.....	50
SET SERVER NAmE .....	50
SET SNMP GETCOMM.....	50
SET SNMP JETADmin.....	51
SET SNMP SETCOMM1.....	51
SET SNMP SETCOMM2.....	51
SET SNMP CONtact.....	51
SET SNMP LOCation .....	51
SH SERIAL .....	51
SH SERVER.....	52
SH SERVER CO.....	52
SH SNMP .....	52
SH VErSion.....	52
Zero .....	52
Service Commands .....	53
SET SERVI <service name> BOT .....	53
SET SERVI <service name> EOT .....	53
SH SERVI STRings [ <i>string_num</i> ].....	53
SET SERVI <service name> FIlter .....	53
SH SERVI FIlters.....	53
SET SERVI <service name> FMS .....	53
SET SERVI <service name> FRs .....	54
SET SERVI <service name> IP.....	54
SET SERVI <service name> NAmE.....	54
SET SERVI <service name> POrt.....	54
SET SERVI <service name> PRiOrity.....	54
SH SERVI PRI [ <i>service_num</i> ].....	54
SET SERVI <service name> RECeive.....	55
SET SERVI <service name> TCP.....	55
SET SERVI <service name> QUEUE.....	55
SH SERVI SUMmary [ <i>service_num</i> ].....	55
String Commands .....	55
SET STRing.....	55
CL STRing.....	55
SH STRing [ <i>string_num</i> ].....	56
SH FIlters .....	56
TCP/IP Commands.....	56
SET IP ACcess .....	56
SET IP RANge .....	56
SH IP ACcess .....	57
SET IP AdDress.....	57
SET IP ARP ENable.....	57
SET IP BAnner .....	57
SET IP CHKSUM .....	57
SET IP BOrt.....	57
SET IP ENable .....	57
SET IP FTIme.....	58
SET IP FTP.....	58

---

SET IP HTTP .....	58
SET IP KEepalive.....	58
SET IP LPD .....	58
SET IP MMethod .....	58
SET IP PIng.....	58
SET IP PRObe.....	58
SET IP RARp .....	59
SET IP REtry.....	59
SET IP ROuter.....	59
SET IP SUBnet.....	59
SET IP TCP .....	59
SET IP TELnet .....	59
SET IP TFTP.....	59
SET IP TImeout.....	60
SET IP WIndow.....	60
SH IP .....	60
Power Configuration Commands .....	60
SET POWER DELAY nnnn.....	60
SET POWER PERIOD nnnn.....	60
SET POWER WINDOW nnnn.....	60
Firmware Update .....	62
SET LOAd ENable.....	62
SET LOAd HOst .....	62
SET LOAd IP .....	62
SET LOAd SOftware.....	62
SET LOAd TFTP.....	62
SET LOAd XModem.....	62
SH LOAd.....	63
Other Commands.....	64
SET DEFAULT .....	64
EXIT .....	64
SH FATal.....	64
CL FATal.....	64
SH FREE .....	64
HElp <command> .....	64
INIT .....	64
SET PAssword.....	65
SET POWERON .....	65
SH POWERON .....	65
SET PROTECT.....	65
CL PROTECT.....	65
SAVE.....	65
SH TEst .....	65
UNPROTECT.....	66
Netware Commands .....	66
SET NETW ADvertise .....	66
SET NETW ENable.....	66
SET NETW FRame .....	66
SET NETW NPrinter.....	66
SET NETW PAssword .....	66
SET NETW POLLing .....	66
SET NETW QServer .....	67
SET NETW REscan .....	67
SET NETW SERver .....	67
CL NETW SERver .....	67
SH NETWare.....	68
Email Printing Commands.....	68
SET POP3 ADdress.....	68
SET POP3 ENable.....	68

---

---

SET POP3 POLLing .....	68
SET POP3 NAmE .....	68
SET POP3 PAssword .....	69
SET POP3 TImeout .....	69
SET SMTP AdDress.....	69
SET SMTP ENable.....	69
SH POP3.....	70
SH SMTP.....	70
DLC / NETBEUI Commands.....	70
SET DLC ENable .....	70
SET DLC TImeout.....	70
SH DLC.....	70
SET NetBEUI ENable .....	71
SET NETBIOS DOMain .....	71
SET NETBIOS MEthod .....	71
SET NETBIOS PRimary .....	71
SET NETBIOS SEcondary.....	71
Appletalk Commands .....	71
SET APPlEtalk.....	71
SET APPlEtalk ZOne.....	71
Wireless Security Configuration.....	72

# Section 1 – Product Overview

## Introduction

SX-200 Series Print Servers allow you to share a printer equipped with a USB or parallel port on a wired or wireless network. The print server supports and automatically senses both 100baseTX Fast Ethernet and 10baseT Ethernet network connections, and the wireless version allows connections to 802.11a, 802.11b, and 802.11g wireless networks as well. The installation can be performed by the least-experienced users, while providing networking professionals with advanced features for configuration. silex is confident that you will enjoy the many features of this print server. Refer to the Hardware Installation Guide provided in the product package for hardware setup information. For additional information on this product or for downloading firmware upgrades, visit the silex web site at [www.silexamerica.com](http://www.silexamerica.com).

## Package Contents

- silex Print Server
- Power supply adapter
- USB cable
- Hardware Installation Guide
- User's Guide (this document)
- SX-200 Series Print Server Installation CD
- Desktop mounting kit
- Printer mounting kit

### **IMPORTANT**

- ? **Use Adobe Acrobat Reader 5.0 or higher to view or print the PDF files contained on the CD.**
- ? **Fill out and return the electronic warranty card provided on the *SX-200 Series Print Server Installation CD*.**

## About This User's Guide

This User's Guide contains information on system requirements, basic troubleshooting, and instructions on the following:

- Installing the print server hardware
- Configuring the print server for use on your network
- Windows print queue configuration
- Macintosh print queue configuration

## Windows™ System Requirements

To configure the print server settings (wired and wireless versions) using the provided ExtendView Utility in Windows, your Windows-based system should include the following components:

- A PC with a 133 MHz or higher processor
- Microsoft Windows operating system
- At least 64 MB of RAM (memory)
- At least 3 MB of free hard disk space to install the software
- A CD-ROM drive (to load the software)
- A PC equipped with a USB version 1.1 or 2.0 port
- An Internet connection (for online product registration)

## Other Operating System Requirements

Users can access the configuration settings for the Serial Server through a standard web browser by entering the IP address the serial server obtains from a DHCP server. If your network does not have DHCP service, then enter the default static IP address of the Serial Server (192.0.0.192).



## Wireless Print Server Requirements

To print using a wireless print server, you will need an 802.11a, 802.11b, or 802.11g wireless network consisting of either of the following:

- An 802.11a, 802.11b, or 802.11g wireless-enabled PC or Macintosh printing straight to the printer (Ad-Hoc or Peer-to-Peer Mode).
- An 802.11a, 802.11b, or 802.11g wireless access point that allows wireless and wired Ethernet-enabled computers to print to the wireless print server.

To configure and print to the wireless print server, you will need the following information from your wireless network administrator:

- Wireless Mode used (Infrastructure or Ad-Hoc)
- The SSID (service set identifier) for your wireless network.
- If you are using TCP/IP (recommended for Windows Networks) and are not connected to a DHCP server (for obtaining an IP Address automatically), you will need a unique IP Address for the wireless print server (for example: 192.168.1.14). If the wireless print server is not on the same IP subnet as the computers you are printing from, you will also need a subnet mask and a router (default gateway) address.
- Wireless security settings

## Print Server Components

The print server includes the following components. Detailed descriptions of these components are provided below:

- **Power connector** – The power supply cable plugs into this connector.
- **Test button** – Pressing this button for less than three seconds will print a test page on the printer. Pressing and holding this button for more than five seconds will reset the print server to factory default settings.
- **LED status indicators** – used to indicate the operational states of the print server. Refer to the LED status light descriptions on the next page.
- **Ethernet Port** – This port is used for connecting the print server to a 10/100Base-TX Ethernet card, hub, router, or other wired access point for network access.
- **Parallel port** – The parallel port is used for connecting the print server to the IEEE 1284-compliant parallel port of your printer (parallel port models only).
- **USB port** – The USB port is used for connecting the print server to the USB 2.0 port of your printer. You must use a standard USB A (print server side) to B (printer side) cable (USB port models only).

**NOTE:** A USB 2.0 cable must be used to take full advantage of the high-speed USB 2.0 connection.

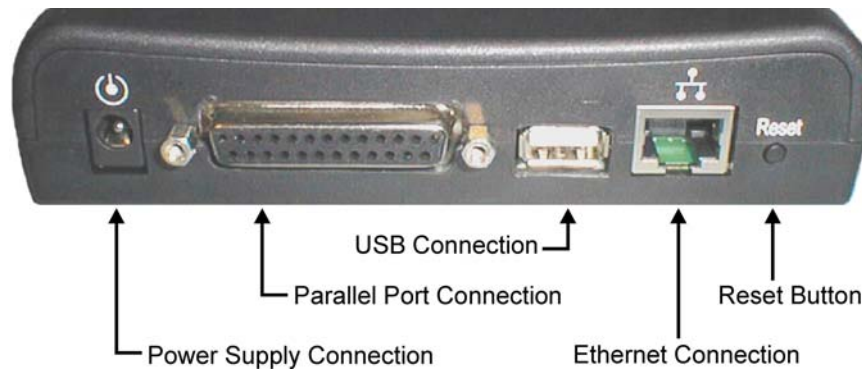

**LED Indicators**

The front edge of the print server provides five Green/Orange LEDs (Light Emitting Diode) indicators for easy monitoring. The following table defines the function of each LED.

Label	Color	State	Status
POWER	GREEN	OFF	The device is not receiving power
		Green ON	The device is ready
		Green Blinking	Device error
10/100	GREEN/ORANGE	OFF	No Ethernet link
		Green ON	100baseTX link
		Green Blinking	100baseTX data
		Orange ON	10baseT link
		Orange Blinking	10baseT data
WIRELESS	GREEN	OFF	No wireless link
		Green ON	Wireless link
		Green Blinking	Wireless data
USB (USB PORT MODELS ONLY)	GREEN/ORANGE	OFF	No printer attached
		Green ON	Printer ready
		Green Blinking	Printer data
		Orange ON	Printer error
PARALLEL (PARALLEL PORT MODELS ONLY)	GREEN/ORANGE	OFF	No device ID detected from printer
		Green ON	Printer ready
		Green Blinking	Printer data
		Orange ON	Printer error

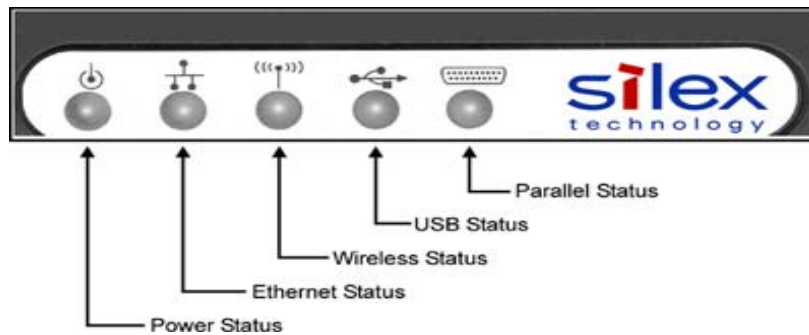

### Pushbutton Functions

The front edge of the print server provides a momentary pushbutton that can be used to print a test/configuration page or reset the device to factory default settings.

Action	Function
Press pushbutton for > 1/8 second but < 5 seconds	Prints a test/configuration page on each connected port
Press pushbutton for > 5 seconds	Resets the device configuration to factory defaults. The unit will reinitialize itself after updating the configuration memory.

### Factory Default Settings

The SX-200 Series Print Server is shipped with a default configuration. The settings can be changed to suit specific installation requirements via the ExtendView Utility, or other SNMP-based utilities, the embedded Web server, or via a Telnet connection to the Print Server's internal console. The factory default settings can be easily restored at any time by performing a cold reset (press and hold the pushbutton on the device for more than five seconds).

#### Default Settings (wired and wireless print servers)

Parameter	Setting
IP Address	190.0.0.192
TCP/IP Method	AUTO (BootP and DHCP are enabled)
Password	access

#### Wireless Default Settings (wireless print servers only)

Parameter	Setting
Wireless Mode	Ad-Hoc (peer-to-peer)
RF Channel	11
ESSID	printer (lower case)

## Section 2 – Hardware Installation

### Before You Begin

Before installing the print server, make sure you have installed and set up your printer as described in the documentation that came with the printer and that your printer functions properly. SX-200 Series Print Servers support a parallel and/or USB connection to your printer.

### Hardware Installation (wired and wireless versions)

**NOTE:** Be sure to review the hardware requirements in the previous section to ensure you have the necessary information before installing the print server.

1. Write down the 12-digit MAC address printed on the label located on the bottom of the print server (for example: 004017023F96). You may need this number in order to configure the print server.
2. Mount the print server on either the printer or the desktop:
  - **Printer mount** – attach the print server to a suitable location on the side or rear of your printer by applying an adhesive Velcro strip (provided in the printer mounting kit) to your printer and at the top of the print server as it is to be attached to your printer.
  - **Desktop mount** – attach the adhesive rubber feet (provided in the desktop mounting kit) to the bottom of the print server as shown below.

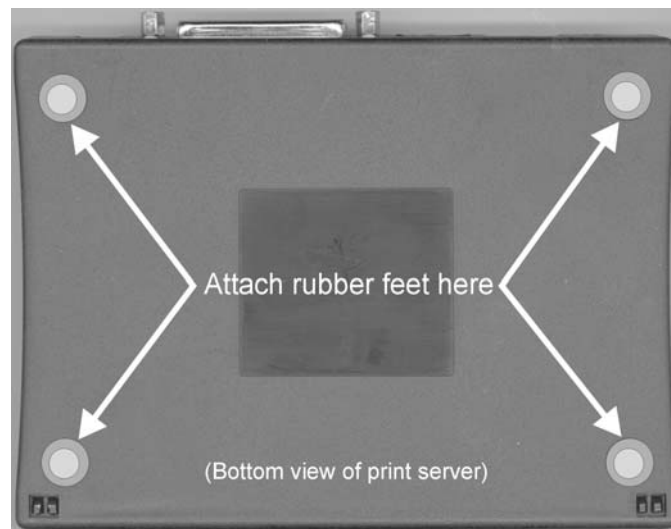

3. Connect the print server to your printer(s) using the USB and/or parallel port of your printer. For a USB connection, use a standard USB A (print server side) to B (printer side) cable. For a parallel connection, use an IEEE 1284-compliant parallel printer cable.
4. Plug the print server power supply adapter into a suitable AC receptacle, and then plug the power supply cable into the print server. The print server will run through a sequence of power-up diagnostics for a few seconds.
  - If the print server is operating properly, the power LED will illuminate continuously (refer to page 1-5 for detailed LED status descriptions).
  - If the power LED blinks continuously in a regular pattern, a problem exists. If this is the case, try powering the print server OFF and then ON again.
  - If the problem persists, refer to the *Troubleshooting* section in this User's Guide.
5. Connect the print server to your network through a switch or hub using a category 5 (CAT5) Ethernet cable. The print server's IP address must be configured before a network connection is available. If your network offers DHCP (Dynamic Host Configuration Protocol), the print server will automatically search for a DHCP server upon power up and obtain an IP address. If your network does not offer DHCP, a static (fixed) IP address must be assigned (see your system administrator for assistance). In most cases, a fixed IP address is preferred because a DHCP server may not always assign the same IP address to the print server when the print server is powered ON.

**NOTE:** The IP address must be within a valid range, unique to your network, and in the same subnet as your PC.

**NOTE:** For wireless print servers, if a wired connection is established to the unit, the wireless link will be disabled.

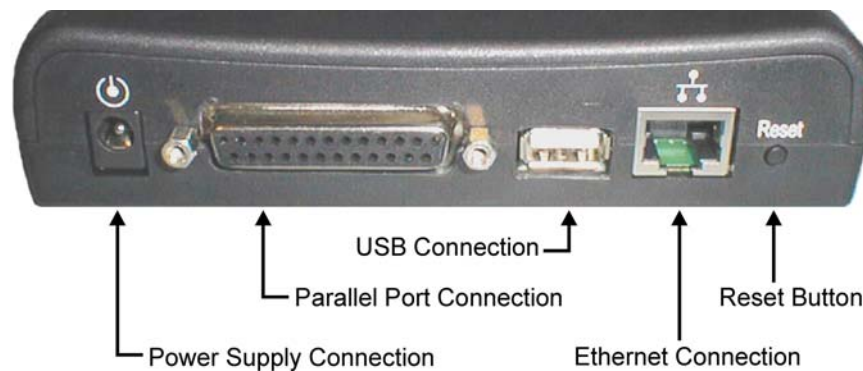

## Verifying the Connection to the Printer

**NOTE:** Before attempting to print, it is very important to verify the connection between the print server and printer. If this connection is not working, you will not be able to print!

1. Verify that both the print server and the printer are powered on and ready, and that a USB or parallel printer cable is properly connected between the print server and printer.
2. Print a test page by pressing the *Test* button once. If the connection is good, a test page will print on the printer. If nothing prints out, make sure that the printer cable is properly connected, your printer is on line, and that no error conditions exist with the printer (off line, paper jam, out of toner, etc.).

**NOTE:** The test page will only work with printers that can directly print PCL, PostScript, or text. It will not work with some "Windows" printers like the HP DeskJet 820 (which performs the image rasterization in the PC), nor will it work with HP-GL/2 or RTL plotters (unless the PostScript option is installed). For such devices, you must print a job from an appropriate application program in order to test the print server-to-printer connection.

## Section 3 – Configuration and Management

### Configuration Options

SX-200 Series Print Servers (wired and wireless models) can be configured using a variety of options, some of which do not require any software installation on the host PC. The print server can be configured and managed via an Ethernet or wireless connection using the ExtendView Utility (recommended), the embedded web (HTTP) server pages, or the print server's internal configuration console, which can be accessed via a Telnet connection. If you choose to use the silex ExtendView Utility (provided on the *Print Server Installation* CD), the software must be installed prior to use. Additional options for print server configuration and management are available as third-party utilities that can be downloaded from their respective web sites. If you are using a wireless print server, you can still configure it via an Ethernet connection or optionally configure it via a wireless connection.

#### ExtendView Utility

- used for advanced print server configuration, and allows you to configure for TCP/IP, Netware, AppleTalk, and the wireless settings (for wireless print server models only).
- uses a 32-bit graphical user interface.
- works with Windows PCs running the TCP/IP protocol.
- included on the Print Server installation CD.
- can be downloaded from the silex web sites:  
USA: <http://www.silexamerica.com>
- after installation, this utility can be run from the START menu.

#### INSTALLING THE EXTENDVIEW UTILITY (WINDOWS OPERATING SYSTEMS):

1. Ensure your PC is connected and has access to your network.
2. Connect an available Ethernet cable from your network hub to the print server. Ensure the print server is powered on.
3. Insert the CD supplied with your print server into the CD-ROM drive of your computer. The CD should automatically start and display a menu screen. Click on *Install Software*.
4. Select *ExtendView*, and then click on *Install*.

#### Web Browser Interface

- allows you to configure the print server with a standard web browser (e.g., Internet Explorer or Mozilla).
- no additional software is needed on the system.
- can be used on any system that supports web browser capabilities.
- type the IP address into your web browser address bar to connect.
- the default password is ACCESS (all uppercase characters).



### HP Web JetAdmin Utility

- a web browser-based HP utility (e.g., Internet Explorer or Mozilla).
- can be downloaded from the HP web site <http://www.hp.com>.

### Configuration Console

- a command-line-oriented console.
- contains advanced features not available through ExtendView or the Web Browser Interface.
- the default password is ACCESS.
- can be accessed via TELNET using the print server's Ethernet connection.
- type **HELP** for a list of console commands.
- More detail on the command console can be found in the Command Console section towards the

**NOTE:** When connected, press ENTER to get the “#” prompt, enter the password ACCESS (will not ‘ECHO’ on your screen), and press ENTER to get a “Local>” prompt (no response required for the “Enter Username>” prompt). When the “Local>” prompt appears, the console is ready to accept commands.

end of this manual.

## Configuring the Print Server via an Ethernet Connection

For Microsoft Windows operating systems, the ExtendView Utility (provided on the *Print Server Installation* CD) is the recommended method of configuring one or more print servers on your network. Once the print server obtains an IP address (occurs automatically when the unit is powered ON and connected to a DHCP network), the ExtendView Utility's auto-discovery feature will search for and locate all print servers on the network and then display the IP address for each discovered print server. For non-Windows operating systems such as Macintosh or Unix systems, a standard web browser (e.g., Microsoft Internet Explorer or Mozilla) can be used to access the configuration settings of the print server (refer to the next page, "Using the Web Browser Interface" instructions). No additional software is required.

### USING THE EXTENDVIEW UTILITY TO CONFIGURE THE PRINT SEVER (WINDOWS OPERATING SYSTEMS):

1. Start the ExtendView Utility from the START Menu.
2. When the Welcome screen appears, click on *Next*, choose any name for your *View Name*, select *Automatically create a view with default settings*, and then click on *Finish*.
3. Double-click on the print server that you want to use from the list. The default print server name is SLXxxxxxx (where xxxxxx is the last six digits of the MAC address from the label located on the back of the print server).
4. If you are using TCP/IP (recommended for Windows) and you do not have a DHCP server (see note below), you will need to manually assign a valid IP Address (if you are not sure what IP address is valid, ask your network administrator), and then click on *OK*.
5. Configure the 802.11a, 802.11b, or 802.11g wireless settings (wireless print servers only). To operate on a wireless network, you must select your country or region from the drop-down list. This field designates the region of operation for which the wireless interface is intended. It may not be legal to operate the print server in a country/region other than the country/region shown in the drop-down list. You must also set the wireless mode (ad-hoc or infrastructure), SSID channel, and WEP encryption of the wireless print server to the same configuration as the wireless network you want the print server to communicate on. All nodes of a wireless network need to have the same settings in order to communicate with each other.
  - wireless mode (ad-hoc or infrastructure)
  - SSID channel
  - wireless security settings

More information can be found in the Wireless Security Configuration Section at the end of this manual.

**NOTE:** It may not be legal to operate the print server in a country or region other than the country or region shown in the drop-down list. If your country or region is not listed, please check with your local government agency.

**NOTE:** If you are using DHCP on your network, the print server should have acquired valid IP settings at this point and no further configuration is necessary. However, for most installations, a static IP address is preferred. If your DHCP server does not allow the print server to keep its assigned IP address permanently, then you must manually assign an IP address. In this case, use a static IP address outside the range reserved for DHCP (see your DHCP server documentation for details). To assign a static IP address, right-click on the print server in the menu, and then select *Configuration*. On the TCP/IP tab, under *IP Address Resolution*, select *Set Permanent*, and assign a valid static IP address for your network. Click on *OK* to save the new settings.

**USING THE WEB BROWSER INTERFACE TO CONFIGURE THE PRINT SERVER (NON-WINDOWS SYSTEMS):**

To configure the print server using non-Windows operating systems (e.g., Unix systems), a standard web browser (e.g., Microsoft Internet Explorer or Netscape Navigator) can be used to access the print server's embedded Web (HTTP) server pages, which contain the print server's configuration options. No additional software is required.

1. Ensure your PC is connected and has access to your network.
2. Connect an available Ethernet cable from your network hub to the print server. Ensure the print server is powered ON.
3. With your printer and print server switched on and ready, press the *test* button on the print server to print a test page. The test page will display the current IP address assigned to the print server by your network DHCP service. If your network does not use DHCP, then the print server will have the default IP address of 192.0.0.192. In any case, your computer must use an IP address other than the one used by the print server in order to establish a connection between the two devices.
4. Configure the 802.11a, 802.11b, or 802.11g wireless settings (wireless print servers only). To operate on a wireless network, you must select your country or region from the drop-down list. This field designates the region of operation for which the wireless interface is intended. It may not be legal to operate the print server in a country/region other than the country/region shown in the drop-down list. You must also set the wireless mode (ad-hoc or infrastructure), SSID channel, and WEP encryption of the wireless print server to the same configuration as the wireless network you want the print server to communicate on. All nodes of a wireless network need to have the same settings in order to communicate with each other.
5. From the host computer, open a standard web browser (e.g., Microsoft Internet Explorer or Netscape Navigator), enter the IP address of the print server into the address bar of the web browser, and then press *Enter*. The Web Browser Utility will be displayed, allowing you to configure the print server. The menu selections are displayed on the left side of the screen, and the individual settings are located at the top of the screen. Use the browser's *Forward* and *Back* buttons to navigate to the sub pages where you can configure the print server's settings.

**NOTE:** It may not be legal to operate the print server in a country or region other than the country or region shown in the drop-down list in ExtendView. If your country or region is not listed, check with your local government agency.

**USING A THE INTERNAL COMMAND CONSOLE TO CONFIGURE THE PRINT SERVER:**

The command console can be accessed using a Telnet connection via an Ethernet connection. To use a Telnet connection, follow these steps:

1. Ensure the print server is connected via an Ethernet cable to the host computer.
2. From the Windows *Start* menu, click on *Run*, and then type the following command (where x.x.x.x. is the IP address of the print server).

**telnet X.X.X.X**

After a connection is established, press RETURN or ENTER to get the '#' prompt, enter the password ACCESS (it will not 'echo' on your screen), and type anything in response to the *Enter Username>* prompt. When you get the *Local>* prompt, you are ready to enter commands. Type *Help* for a list of console commands.

**First-Time Configuration of the Wireless Print Server Using 802.11b or 802.11g (wireless print servers only)**

It is recommended that you initially configure the print server via a wired connection. However, if you choose to configure the wireless print server for the first time from a computer via an 802.11b or 802.11g wireless connection, you will need to temporarily change the settings on your computer to match the default settings of the print server as follows:

- Wireless Mode: *Ad-Hoc* (sometimes referred to as Peer-to-Peer)
- Channel: *11*
- SSID (or wireless network name): *printer*

**NOTE:** It is not necessary to change your computer's settings if you are configuring the print server's settings via an Ethernet connection. The 802.11a wireless protocol cannot be used for this method of configuration.

You should now be able to configure your print server using either the ExtendView Utility or the Web Browser Configuration as described in the previous sections. For wireless security configuration, see

**NOTE:** Be sure to set your PC back to its original wireless settings after you finish configuring the wireless print server.

## Windows Print Queue Configuration

It is recommended to use the *ExtendNet Connect for TCP/IP* software for Windows printer port configuration (provided on the *Print Server Installation* CD). The Print Servers are also compatible with Windows standard TCP/IP port and LPR ports. If you are using the Windows standard TCP/IP port, the default port number is 9100. Perform the following steps to install and use ExtendNet Connect for TCP/IP:

1. Install the ExtendConnect IP Port Monitor by inserting the CD supplied with your print server and clicking on *Install Software*.
2. Select *ExtendNet Connect Windows Printing*, click on *Next*, click on *ExtendNet Connect for TCP/IP*, and then click on *Install*. Follow the on-screen instructions to complete this installation.
3. Install the printer driver software according to the documentation for the printer.
4. Click the Windows *Start* button, select *Settings*, and then *Printers* (*Start*, then *Printers and Faxes* if you are using Windows XP).
5. Right-click on the printer you wish to associate with the network port, and then select *Properties*.
6. If you are using Windows NT/2000/XP/2003, go to the *Ports* tab. If you are using Windows 95/98/ME, go to the *Details* tab, and then click on *Add Port*.
7. If you are using Windows NT/2000/XP/2003, highlight *ExtendNet Connect IP Monitor*, and then click on *New Port*.
8. If you are running Windows 95/98/ME, select *Other*, highlight *ExtendNet Connect IP Monitor*, and then click on *OK*. The search will begin for available print servers.
9. Highlight the print server you would like to create the port for, and then click on *ADD*.
10. Make sure the port you created is chosen, and then click on *Apply*. You are now ready to print.

## Macintosh Print Queue Configuration

Silex Print Servers support the AppleTalk protocol running over Ethernet (also known as EtherTalk). This capability allows Macintosh computers to print jobs to a printer simultaneously with jobs from Windows, UNIX, NetWare, and other computers.

**NOTE:** silex Print Servers are also compatible with the Macintosh TCP/IP Printer option in the Print Center as long as you have a valid IP Address configured (refer to the section "Configuring your print server"). Enter the IP Address of the print server for the "Printer's Address", and make sure the "Use default queue on server" option is checked, and select your correct "Printer Model".

silex print server AppleTalk capabilities allow a printer to appear as a shareable printer node on an AppleTalk Phase 2 network. The print server broadcasts information to Macintoshes on the network, and automatically appears in the Print Center or Chooser of each Macintosh. Application programs (such as Microsoft Word, Excel, PageMaker, etc.) can print without modification or special software on the Macintosh.

### **MACINTOSH CONFIGURATION (OS 8.X AND 9.X):**

Identify the printer to which the print server is connected, and install the printer driver.

1. Verify that Ethernet is enabled from the Network Control Panel or AppleTalk Control Panel.
2. At a Macintosh workstation, from the Apple menu, open the Chooser.
3. If the Chooser window displays an AppleTalk zone list, select the necessary zone. Click on the icon for the printer driver you are going to use. If you have a Postscript printer, you can use the LaserWriter driver.
4. Select the print server name (the default is SLXxxxxxx\_P1\_AT, where "xxxxxx" are the last six digits of the Ethernet address.).
5. Close the Chooser. You can now print to the printer using any standard Macintosh application program.

**MACINTOSH CONFIGURATION (OS 10.x)**

1. If you have not done so already, set the name of your computer by going to the Applications folder\*, selecting *System Preferences*, and then *Sharing*. Type in the computer name in the Network Identity section (you can also set the IP address here if you want).
2. Turn on *Ethernet* and *AppleTalk* by clicking on the Applications folder and clicking on *Network*. Next to *Configure*: select *Built-in Ethernet* (you can leave the *Location*: setting as *Automatic*).
3. Click on the *AppleTalk* tab; ensure the box next to *Make AppleTalk Active* is checked. If necessary, select the appropriate AppleTalk Zone (you can leave the *Configure*: setting as *Automatic*).
4. Now go to the *Applications* folder, open the *Utilities* folder, and select *Print Center*. The Printer List will appear (it will be empty if you have no printers configured). Click on *Add Printer...*, and then select *AppleTalk* instead of *Directory Services*.
5. All of the available AppleTalk printers on the network should appear. Click on the one you wish to add, and then click *Add*. The printer will now appear in the Printer List.
6. To print from an application program, go to *File* and then *Print*, select the desired printer, and then click on *Print*.

\***NOTE:** The Applications folder can generally be reached by double-clicking on the Macintosh HD icon on the desktop.

**NOTE:** silex print servers are also compatible with the Macintosh TCP/IP Printer option in the Print Center as long as you have a valid IP Address configured (refer to the section "Configuring your print server"). Enter the IP Address of the print server for the "Printer's Address", and make sure the "Use default queue on server" option is checked, and select your correct "Printer Model".

**Configuring to Print Using TCP/IP (OS 10.x)**

1. From the System Dock, click on the *Print Center* icon, and then click on *Add*.
2. Select *IP Printing* and enter the IP address of the device. Make sure that *Use Default Queue on Server* option is checked.
3. Select the appropriate Printer model, and then click on *Add*. The printer is now ready to accept jobs.

## Section 4 – Troubleshooting

### Introduction

This section describes procedures for troubleshooting problems you may encounter with the print server, and is divided into the following sections:

- Installation Problems
- Intermittent Problems
- Protocol-Specific Troubleshooting

If you have followed the steps in this section and you believe that you have a defective print server, then please refer to Section 5 – *Where to Get Help* for information on returning defective products.

### Printing Problems

If you cannot print to the print server after you install it, check the following:

- Make sure that the printer is powered on and is on-line, and that all cables are securely plugged in.

If the printer initializes successfully but you cannot print, the problem could be one of the following:

- There is a problem with the interface between the print server and the printer.
- There is a problem with the network connection or cabling.
- There is a queue setup problem, a print server setup problem, or other protocol-related problem.

### Checking the Interface between the Print Server and the Printer:

1. Ensure that the print server is securely plugged into the printer.
2. After the printer is powered ON, wait until the printer initializes, and then print a self-test page by pushing the *Test* button on the back of the print server for approximately one second.

**NOTE:** Pushing the Test button for more than five seconds will restore the factory default configuration settings.

- If the self-test does not print, then there is possibly a hardware problem. Double-check the connections. If you still cannot print, then make sure that your printer is capable of printing text, PCL or PostScript (the self-test will not work unless one of these is supported). The only way to test such printers is to use an application program with the correct printer drivers.
- The following are some examples of printers that do not support direct printing of text files:
  - Some Windows printers (usually low-end inkjet printers) perform all the image rasterization in the printer driver, so the printer only understands a raw image file.
  - Many plotters only support HP-GL/2, RTL, or proprietary languages.
- If you are getting distorted printouts, try printing using the generic/text printer driver.



If the self-test page prints successfully but you cannot print a job or you get distorted printouts, make sure the printer is set for the correct Page Description Language. Most new printers support AUTO mode, which means that they will automatically switch between PCL and PostScript. However, older printers like the LaserJet II, LaserJet III, and LaserJet IIISi require that the printer be set to the desired language through the printer control panel. Also, verify that you have set up the drivers correctly on the workstation. Some printers, like the Epson Stylus, require special drivers and will not print if standard PCL or PostScript drivers are used.

### Checking the Network Connection and Cabling:

If the self-test page prints but you cannot print documents, first check the network connection and cabling.

- If the appropriate LEDs are not on, there is probably a bad 10baseT or 100baseTX cable, or the hub port is bad. If possible, try a different cable and hub port, or try connecting a different device to the cable.
- If you are using a hub, verify that the hub port is good by trying the print server on a different port.
- If you have a bridge or router located between the print server and the host computer, make sure that the device is set up to allow the print server to send and receive data from the host. For example, a bridge can be set up to only allow certain types of Ethernet addresses to pass through (a process known as filtering); therefore, such a bridge must be configured to allow print server addresses. Likewise, a router can be set up to pass only certain protocols, so be sure that the desired protocol can be passed through to the print server. In the case of routers, also make sure that the protocol is routable (LAT, NetBEUI, and DLC/LLC are not routable).
- If the job exists in the queue but does not print, ensure that you are not trying to print a text job to a PostScript printer. If you have a printer that is capable of automatic language switching, ensure that the printer is not forced into PostScript mode.
- Make sure that you are not trying to perform an illegal operation, such as attempting to print a legal-size form when the printer only supports 8.5" x 11" paper.

### Troubleshooting Windows Problems

If you are having trouble printing with Windows, ensure you can ping the print server using the DOS command `PING ipaddress`, where *ipaddress* is the IP address of the print server. If you cannot ping the print server, you will not be able to print.

## Troubleshooting Network Configuration Problems

- If you are using TCP/IP, make sure that your computer and the print server are on the same IP segment or can reach each other with a PING command from the host. The IP address you assign to the print server must be on the same logical network as your host computers (e.g., if your computer has an IP address of 192.189.207.3, the print server should have an IP of 192.189.207.x, where x is an integer between 1 and 254), or you must properly configure your router address to work with the print server.
- If your print server is set to Auto or DHCP for obtaining an IP address, it is possible that the print server's IP address can change. Either configure your DHCP server to give the print server a permanent lease, or configure the print server to be on a STATIC address outside the scope of DHCP addresses.
- The problem may be the result of mismatched or duplicate IP addresses. Verify that the IP address is correctly loaded into the print server (via the self-test page or through the remote console) and make sure that no other nodes on the network have this address (duplicate addresses are the biggest cause of TCP/IP printing problems). If the address is not correct, then verify that the loading procedure was properly executed.
- Also verify that the host computer and the print server are either on the same subnet (for example, if the print server has a subnet mask of 255.255.255.0, the host must have the same subnet mask) or that the router is properly configured to pass data between the two devices.
- If the wrong IP address is loaded, check your network for file servers that have DHCP, BOOTP, or rarp enabled, and make sure that these file servers are not set up to load IP addresses into the print server.

## Troubleshooting Wireless Configuration Problems

- Make sure your computer's wireless adapter and/or access point is configured properly and note the settings, paying special attention to the wireless mode, SSID or network name, WEP or security, and IP address settings so you can configure your print server to the same wireless settings.
- Make sure the radio mode is configured properly for 802.11a or 802.11g if auto mode is not connecting properly.
- Make sure you have a good wireless signal from your PC and from the print server, that the print server is within range (90 meters or 300 feet), and that it is away from metal objects and other devices that generate radio signals (like Bluetooth, Cordless Phones, and Microwave ovens).
- Make sure your computer is set to infrastructure mode if you are connecting through an access point, or ad-hoc (802.11) if you are connecting to the print server without an access point. See the documentation for your wireless adapter for details.
- If you want to use WEP encryption or password protection for your wireless network, and your wireless adapter or access point normally uses a password or passphrase instead of WEP, it should allow you to enter 0x followed by a ten digit (for 40-bit or 64-bit WEP) or twenty-six digit (for 128-bit WEP) key in hexadecimal format (0-9 or A-F).
- If you are using ad-hoc (peer to peer) mode and are experiencing slow performance or are having intermittent problems connecting, try changing the RF channel of your wireless network. Refer to your wireless adapter and/or access point documentation for more information. It is recommended that you change the RF channel to at least three channels lower or higher than any other wireless networks within range. The RF channel can be changed via the ExtendView Utility or the Web Browser Configuration Utility for the print server.

## **Section 5 – Where to Get Help**

silex offers several customer support options to assist you in the event you experience difficulties with your print server, including telephone support, repair services, and warranty.

The worldwide web site provides a quick and easy way to answer many common technical questions. It includes a wide variety of technical support tips, as well as copies of product manuals, product literature, and firmware load images. The web site is located at [www.silexamerica.com](http://www.silexamerica.com).

Your first point of contact for technical support is the Distributor or Dealer from whom you bought your product. They are familiar with your needs, and will generally be able to provide you with the fastest and most comprehensive support.

If your Distributor or Dealer is unable to answer your questions or is for some reason not available, then contact silex directly at (801) 748-1199. Or you can send an e-mail to: [support@silexamerica.com](mailto:support@silexamerica.com).

Before contacting Technical Support, please refer to the troubleshooting suggestions or the web site in this manual to isolate any problems, and be sure to write down any error messages. Also, make sure that you have the serial number of the product (located on the product label on the card).

## Returning Products

If you need to return a product for any reason (failures, incorrect shipments, etc.), follow the steps below:

1. Contact the Technical Support group at (801) 748-1199 to request a Return Goods Authorization (RGA) number.
2. Be prepared with the serial number of the unit you are returning. You will be asked for the serial number to verify warranty coverage.

Please record these serial numbers in the space provided below for future reference.

**Print Server Model #:** \_\_\_\_\_

**Print Server S/N:** \_\_\_\_\_

## Appendix A – Safety and Regulatory Notices

### Information for United States Users

This equipment has been tested and found to comply within the limits for a Class B digital device pursuant to Part 15 of the FCC Rules. These limits are designed to provide reasonable protection against harmful interference in a residential installation. This equipment generates, uses, and can radiate radio frequency energy and, if not installed and used in accordance with the instructions, may cause harmful interference to radio communications. However, there is no guarantee that interference will not occur in a particular installation. If this equipment does cause harmful interference to radio and television reception, which can be determined by turning the equipment off and on, the user is encouraged to try to correct the interference by one or more of the following measures:

- Reorient or relocate the receiving antenna.
- Increase the separation between the equipment and receiver,
- Connect the equipment into an outlet on a circuit different from that to which the receiver is connected.
- Consult the dealer or an experienced radio/TV technician for help.

The user is cautioned that changes and modifications made to the equipment without the approval of manufacturer could void the user's authority to operate this equipment.

Operation is subject to the following two conditions: (1) This device may not cause harmful interference, and (2) this device must accept any interference received, including interference that may cause undesired operation.

The radiated output power of the print server is far below the FCC radio frequency exposure limits. Nevertheless, print server shall be used in such a manner that the potential for human contact during normal operation is minimized.

To satisfy RF exposure requirements, this device and its antenna(s) must operate with a separation distance of at least 20 centimeters from all persons and must not be co-located or operating in conjunction with any other antenna or transmitter. End-users must be provided with specific operating instructions for satisfying RF exposure compliance.

### Channel

The Wireless Channel sets the radio frequency used for communication.

- Access Points use a fixed Channel. You can select the Channel used. This allows you to choose a Channel which provides the least interference and best performance. In the USA and Canada, 11 channels are available. If using multiple Access Points, it is better if adjacent Access Points use different Channels to reduce interference.
- In "Infrastructure" mode, Wireless Stations normally scan all Channels, looking for an Access Point. If more than one Access Point can be used, the one with the strongest signal is used. (This can only happen within an ESS.)
- If using "Ad-hoc" mode (no Access Point), all Wireless stations should be set to use the same Channel. However, most Wireless stations will still scan all Channels to see if there is an existing "Ad-hoc" group they can join.

Note: This equipment marketed in USA is restricted by firmware to only operate on 2.4G channel 1-11

## Declaration of Conformity (FCC)

According to 47CFR, Part 2 and 15 for Class B Personal Computers and Peripherals; and/or CPU Boards and Power Supplies used with Class B Personal Computers:

We: silex technology america, Inc.  
 Located at: 157 West 7065 South  
 Salt Lake City, UT 84047, USA

Declare under sole responsibility that the product identified herein, complies with 47CFR Part 2 and 15 of the FCC rules as a Class B digital device FOR HOME OR OFFICE USE. Each product marketed, is identical to the representative unit tested and found to be compliant with the standards. Records maintained continue to reflect the equipment being produced can be expected to be within the variation accepted, due to quantity production and testing on a statistical basis as required by 47CFR §2.909. Operation is subject to the following two conditions: (1) this device may not cause harmful interference, and (2) this device must accept any interference received, including interference that may cause undesired operation.

Trade Name: silex  
 Type of Product: Ethernet and Wireless 802.11a, 802.11b, and 802.11g-enabled print server  
 Model: SX-200 Series

silex technology america, Inc. hereby declares that the equipment specified above conforms to the above requirements.

Standards used and met in the assessment:

- EN55022: 1998 Class B; CFR Title 47, Part 15, Subpart B, Subpart C, and Subpart E.

## Information for Canadian Users (IC notice)

The term “IC” before the radio certification number only signifies that Industry of Canada technical specifications were met. Operation is subject to the following two conditions: (1) this device may not cause interference, and (2) this device must accept any interference, including interference that may cause undesired operation of the device.

This Class B digital apparatus meets all requirements of the Canadian Interference-Causing Equipment Regulations.

To prevent radio interference to the licensed service, this device is intended to be operated indoors and away from windows to provide maximum shielding. Equipment that is installed outdoors is subject to licensing.

This device has been designed to operate with an antenna having a maximum gain of 2 dB. Antenna having a higher gain is strictly prohibited per regulations of Industry Canada. The required antenna impedance is 50 ohms.

To reduce potential radio interference to other users, the antenna type and its gain should be so chosen than the equivalent isotropically radiated power (EIRP) is not more than the required for successful communication.

## Information for European Users

The print server and its built-in 802.11a, 802.11b, and 802.11g wireless technology is in compliance with the Class B Information Technology Equipment requirements and other relevant provisions of European Directive 1999/5/EC. The limits for Class B equipment were derived for typical residential environments to provide reasonable protection against interference with licensed communications devices. The internal function is a radio device using the 2.4 GHz frequency band (2.400GHz - 2.4845 GHz) and 5. GHz frequency band ( 5.150GHz - 5.825GHz). It is intended for wireless communication with other 802.11a, 802.11b, and 802.11g-enabled devices in an indoor environment.

The use of 802.11a, 802.11b, and 802.11g wireless technology in certain countries may be restricted. Before using 802.11x products, please confirm with the frequency management authority in the country where you plan to use it. Many countries allow indoor use only. In Italy, general authorization is required if used outside. In France, the use of certain channels is restricted outdoors. In some situations or environments, the use of 802.11x wireless technology might be restricted by the proprietor of the building or responsible representatives of the organization, for example, in airplanes, in hospitals or in any other environment where the risk of interference with other devices or services is perceived or identified as harmful.

If you are uncertain of the policy that applies to the use in a specific organization or environment, you are encouraged to ask for authorization to use 802.11x wireless technology prior to switching it on. Consult your physician or the manufacturer of personal medical devices (pacemakers, hearing aids, etc.) regarding any restrictions on the use of 802.11x wireless technology.

silex cannot be responsible for any failure to satisfy the protection requirements resulting from a non-recommended modification of the product.

## Declaration of Conformity (CE)

Manufacturer: silex technology america, Inc.  
157 West 7065 South  
Salt Lake City, UT 84047, USA

Telephone: (801) 748-1199

Product: Ethernet and Wireless 802.11a, 802.11b, and 802.11g-enabled print server  
Model No.: SX-200 Series

silex technology america, Inc., Inc. hereby declares that the above-referenced product, to which this declaration relates, in is conformity with the provisions of:

Council Directives 1999/5/EC (March 9, 1999), Radio Equipment and Telecommunications Terminal Equipment.

Standards used and met in the assessment:

- EN301 489-1 (V1.5.1, 2004-11)
- EN301 489-17 (V1.2.1, 2002-08)
- EN300 328 (V1.5.1, 2004-08)
- EN60950

The documents required by this Directive are maintained at the corporate headquarters of silex technology america, Inc., 157 West 7065 South, Salt Lake City, UT 84047, USA



## Appendix B – Updating Firmware

### Loading New Firmware (Using the TCP/IP Update Utility)

The silex print server's internal firmware can be easily updated as updates become available. Please visit the silex web site for more information on how to download the latest firmware updates at [www.silexamerica.com](http://www.silexamerica.com). Updating the print server's firmware will not change any user-defined configuration options.

1. Run the Update utility for TCP/IP. The **About Update for TCP/IP** window will be displayed. Click on **OK** to continue. The **Select Update File** window will be displayed.

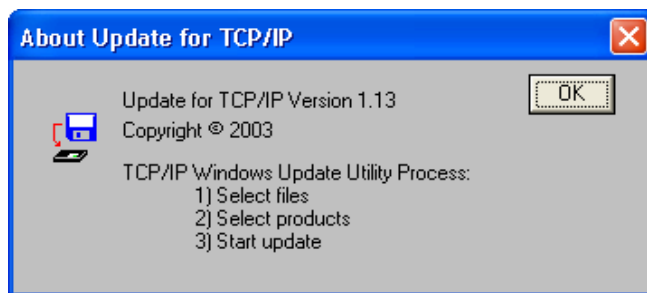

2. Select **UpdateFiles (\*.bin)** file type, locate the print server bin file, and then click on **Open**. A window will be displayed (see next page) showing the file(s) you have selected including the revision level and date code for each file.

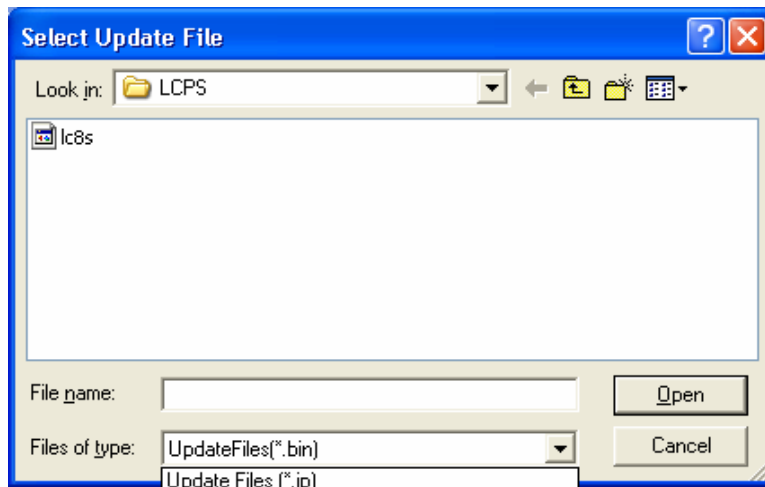

3. Verify that the file(s) are correct, and then click on **OK**. The utility will start searching for qualified print servers present on the network.

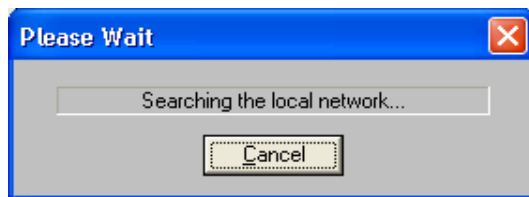
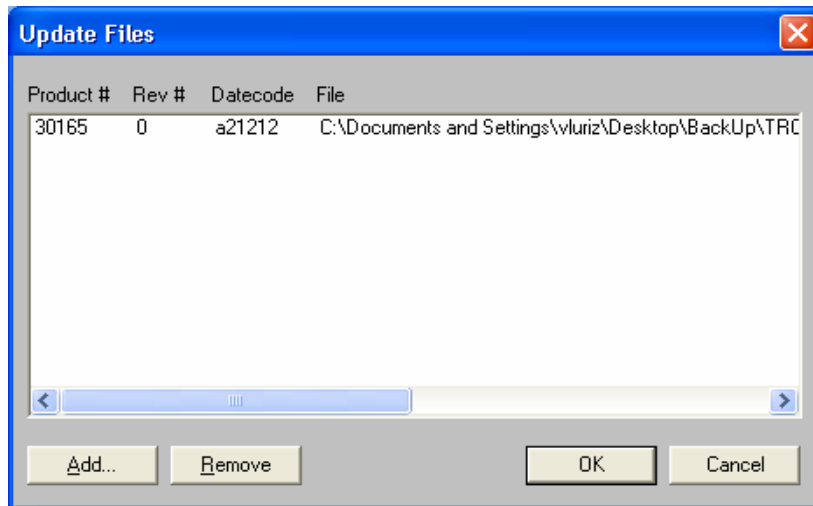

4. When the search process is complete, click on **OK** to continue. A list of discovered devices will be displayed.

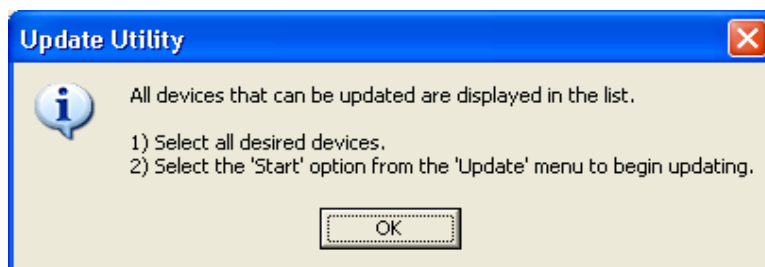

5. Select the desired print server to be upgraded, click on the green icon, or click on **UPDATE** → **START**. The firmware update process will begin automatically as soon as the print server is ready.

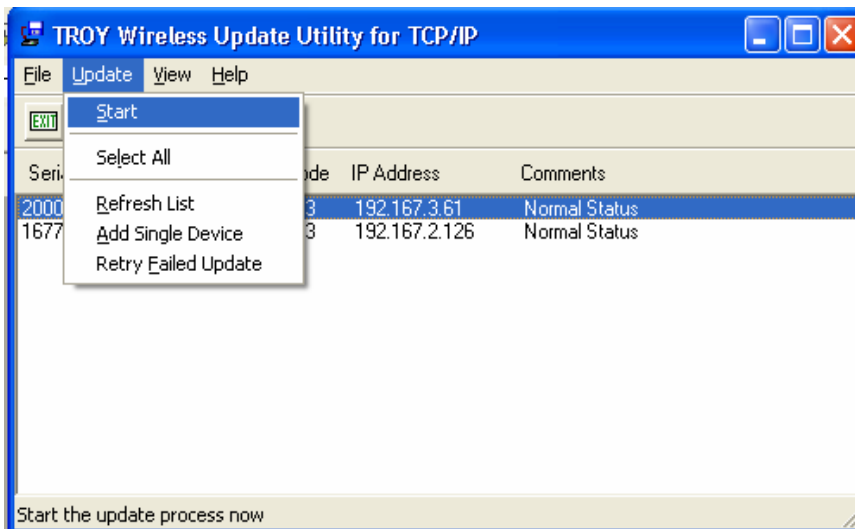
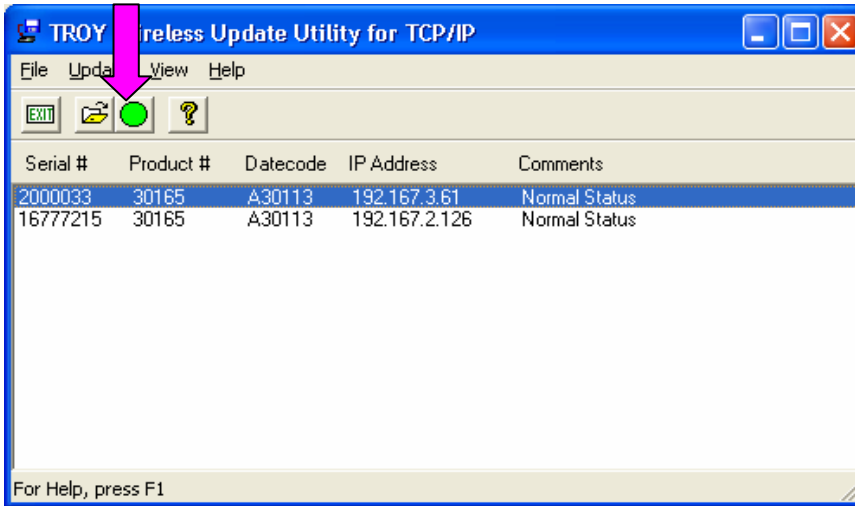

6. When the print server is ready, the firmware upgrade will begin. The IP address of the print server as well as the file you are loading will be displayed.

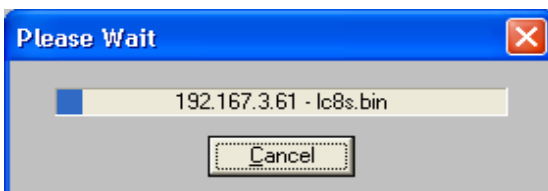
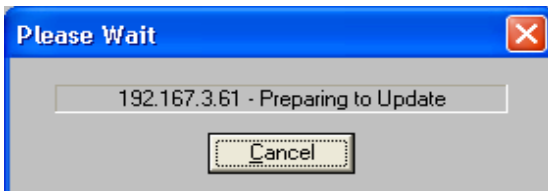

- The update log will be displayed when the update process is finished. Click on *Close* to continue.

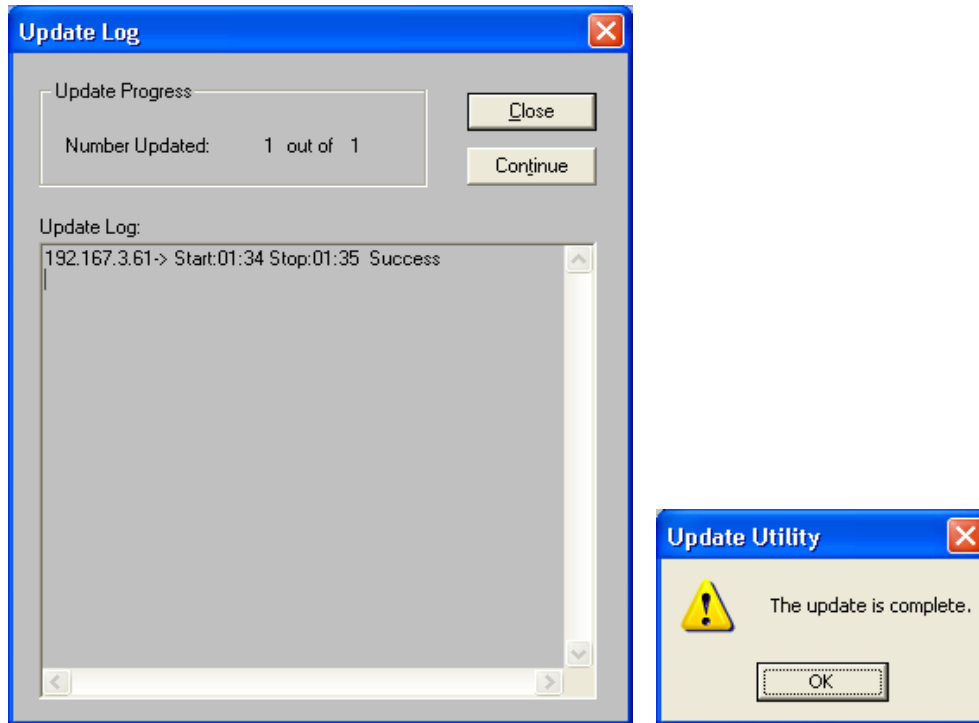

## Loading New Firmware (Macintosh OS-X)

**NOTE:** To upgrade your print server's firmware from operating systems other than Windows or Macintosh, refer to the Print server Administrator's Guide (provided in PDF format on the Print Server Installation CD).

- If you are using the Macintosh OS-X operating system, download the firmware file to your desktop.
- Go to the terminal command prompt and type *cd desktop*.
- Type *tftp* <enter the IP address of the print server>, and then press *Enter* (e.g., *tftp 192.168.0.4*).
- Type *binary*, and then press *Enter*.
- At the *tftp>* prompt, type *put* <firmware file name> <password of the print server> (example: *put ppusb.bin access*).

## Command console access information

silex servers support a sophisticated command-line oriented console for configuration and management. The console includes some features that are not available through other configuration methods. The console can be accessed via TELNET, the server's serial port (if applicable), or through the ADMIN web page using the web browser interface. The general configuration procedure is the same regardless of which method is used. This document describes the console commands available from the command console for silex servers. All commands may not be applicable towards your product.

The general configuration procedure is the same, regardless of which method is used.

### Telnet Command Console Access

To connect to the print server using TELNET on UNIX, Windows, or most other TCP/IP systems, type the following command at the command prompt:

```
TELNET ipaddress
```

Where ipaddress is the IP address of the silex server. When you are connected, press RETURN or ENTER to get the "#" prompt, enter the password (ACCESS is the default, it will not echo on your screen as you type), Hit ENTER until you get the Local> prompt. You are now ready to enter commands.

### Serial Port Command Console Access

Attach a null modem serial cable to the DB9 serial port of the print server, and the other side to the COM port on your computer. Start a terminal emulation program (for example, HyperTerminal on Windows systems). Make sure you are connecting with the relevant COM port on from your PC and use the following settings for the connection:

```
BITS PER SECOND:      115200
DATA BITS:             8
PARITY:                NONE
STOP BITS:             1
FLOW CONTROL:         NONE
```

Once connected, hit ENTER until you get a Local> prompt. You are now ready to enter commands.

## Network Commands

This group of commands configures network parameters

### SH NW

Displays summary network information

sample output:

```
WiFi Mode = INFRASTRUCTURE
WiFi SSID: silex
Speed = 11
Regulatory Domain = 704
WiFi FW Ver = 1F 1.7.1
AP density = LOW
TTLS is Disabled
```

```
WEP is Disabled
Link DOWN
```

## SET NW AUTHtype

Sets WLAN Authentication type

```
SET NW AUTHtype [OPEN | SHARED | TTLS | LEAP | PEAP | WPA-PSK]
                (default = Open System)
```

## SH NW AUTH

Shows the wireless authentication type

sample output:

```
Authentication type= OPEN SYSTEM
```

## SET NW CHannel

Sets WLAN ad-hoc channel number

```
SET NW CHannel n
                n =
1,2,3,4,5,6,7,8,9,10,11,36,40,44,48,52,56,60,64,100,104,108,112,116,120,124,128,132,136,140,149,153,157,161,165 (default = 11, this value is ignored in
Infrastructure mode)
```

## SET NW ENC

Sets WLAN Encryption Mode. Supported modes are none, 64 bit WEP, 128 bit WEP, and TKIP (WPA).

```
SET NW ENC [Disable | 64 | 128 | WPA | WPA2 | WPA2-WPA | Dynamic WEP ]
            (default = Disable)
```

## SH NW ENC

Shows the wireless encryption mode

sample output:

```
WiFi encryption is Disabled
```

Note:

The deprecated command SH NW WEP will also display this information

## SET NW KEY#

Selects WLAN WEP key entry

```
SET NW KEY#    n
                n = 1-4 (default = 1)
```

---



---

## SET NW KEYVAL

Sets the currently selected WLAN WEP key entry to the hex value given.

```
SET NW KEYVAL <key>
    key=10 or 26 hex characters (default=<null>)
```

## SET NW M0de

Sets WLAN mode

```
SET NW M0de <mode>
    [Infrastructure | Ad-Hoc] (default = Infra)
```

## SET NW RAdio

Sets WLAN Radio Mode

```
SET NW RAdio <mode>
    [ 802.11a | 802.11b-g | 802.11a-b-g] (default = 802.11b-g)
```

## SH NW MODE

Shows the wireless operating mode

sample output:

```
Wifi mode = AD-HOC (802.11)
```

## SH NW RADio

Shows the selected radio mode of operation

sample output:

```
Radio mode is 802.11b
```

## SET NW SPeed

Sets maximum WLAN speed

```
SET NW SPeed n
    n = 1,2,5.5,6,9,11,12,18,24,48,54 (default = 54)
```

## SH NW SPEED

Show the maximum wireless data speed in megabits per second

sample output:

```
Speed = 11
```

## SET NW SSid

Sets WLAN SSID

```
SET NW SSid <name>
    User defined (default = printer)
```

## CL NW SSid

Clears the SSID value so the server will connect to any AP.

```
CL NW SSid
```

## SET NW BSsid

Sets WLAN BSSID (connect to a specific access point's mac address)

```
SET NW BSsid <value>
    User defined (MAC Address)
```

## CL NW BSsid

Clears the BSSID value so the server uses just SSID and not a specific AP.

```
CL NW BSsid
```

## SET NW RTS

Sets WLAN RTS threshold

```
SET NW RTS n
    n = 1-3000 (default = 2432)
```

## SH NW RTS

Shows the configured wireless RTS threshold

sample output:

```
Wifi RTS Threshold = 2432
```

## SET NW APDEN

Sets WLAN Access Point Density

```
SET NW APDEN [LOW | MED | HI]
    (default = LOW)
```

## SH NW APDEN



Shows the access point density

sample output:

```
AP Density = Low
```

## SH NW STATS

Show the network I/O statistics

sample output:

```
WiFi statistics:
TX Unicast frames: 0
TX Multicast frames: 0
TX Fragments: 0
TX Unicast octets: 0
TX Multicast octets: 0
TX Deferred: 0
TX Single retry frames: 0
TX Multiple retry frames: 0
TX Retry limit exceeded: 0
TX Discards: 0
RX Unicast frames: 0
RX Multicast frames: 0
RX Fragments: 0
RX Unicast octets: 0
RX Multicast octets: 0
RX FCS errors: 0
RX Discards no buffer: 0
TX Discards wrong SA: 0
RX Discards WEP undecr: 0
RX Msg in msg fragments: 0
RX Msg in Bad msg fragments: 0
```

## SET NW CERTCN

Sets EAP Common Name

```
SET NW CERTCN <name>
User defined (default=<null>)
```

## SH NW CERTCN

Shows the value of the first common name check string

sample output:

```
Common name 1
```

Note: the default for this string is a null (blank) string

Note: The deprecated command SH NW TTCN will also return this information.

## SET NW CERTCN2

Sets second EAP Common Name

```
SET NW CERTCN2 <name>
```

---

User defined (default=<null>)

## SH NW CERTCN2

Shows the value of the second common name check string

sample output:

```
Common name 2
```

Note: the default for this string is a null (blank) string

## SET NW CERTEXP

Sets EAP Certificate Exponent value

```
SET NW CERTEXP <exponent>
User defined (default = 10001 Hex)
```

## SH NW CERTEXP

Shows the value of the certificate exponent

sample output:

```
65537 (10001h)
```

Note: The deprecated command SH NW TTEXP will also return this information.

## SET NW CERTKEY

Sets EAP Root Key

```
SET NW CERTKEY <key value>
User defined
```

## SET NW ID

Sets Authentication User ID This may include the realm, separated by a '@' character.

```
SET NW ID <user id>
(default = anonymous)
```

## SH NW ID

Shows the value of the authentication ID (including realm, if present)

sample output:

```
anonymous@somewhere
```

Note: The default realm is a null (blank) string

Note: The deprecated command SH NW TTID will also return this information.

## SET NW PW

Sets the password used for the 802.1x EAP authentication, if enabled.

```
SET NW PW <password>
      (default = anonymous)
```

## SET NW INAP

Sets EAP Inner-Authentication protocol

```
SET NW INAP [PAP|MSCHAP_V2]
      (default = PAP)
```

## SH NW INAP

Shows the selected inner authentication mode

sample output:

```
Authentication protocol = PAP
```

Note: the deprecated command SH NW TTAP will also return this information.

## SET NW REALM

Sets the realm portion of the 802.1x EAP authentication ID This may also be set with the ID command.

```
SET NW REALM <realm>
      (default = <null>)
```

## SH NW REALM

Shows the realm associated with the authentication ID, if any.

sample output:

```
somewhere
```

Note: The default realm is a null (blank) string

Note: The deprecated command SH NW TTRE will also return this information.

## SET NW WPAAUTO

Enable or disable WPA auto mode. If enabled, the print server will connect to a non-WPA access point if a WPA enabled access point is not available. Only valid when WPA is enabled (authentication type = TKIP).

```
SET NW WPAAUTO [ENable | DIsable]
      (default = disabled)
```

## SH NW WPAAUTO

Shows the state of the WPA auto connect flag

sample output:

```
WPA-AUTO Enabled
```

## SET NW WPAGROUP

Enable or disable WPA group key mode. If enabled, this allows group keys to be used for data link encryption.

```
SET NW WPAGROUP [ENABLE | DISABLE]
      (default = disabled)
```

## SH NW WPAGROUP

Shows the state of the allow WPA group keys flag

sample output:

```
WPA-GROUP Disabled
```

## SET NW WPAPSK

Sets the WPA PSK pass phrase or hex key. This value is only used if the authentication mode is WPA-PSK. The argument to this command is either a pass phrase of 8-63 characters, or exactly 64 hex characters representing the 256 bit PSK value.

```
SET NW WPAPSK <key>
      (default = "silex Group")
```

## SET NW WPATRACE

Sets the WPA trace level. **note:** this command is for diagnostic purposes only, and should not normally be used as the trace can affect performance. A value of 0 disables the trace.

```
SET NW WPATRACE nn
      (default = 0)
```

## SET NW IROAM

### International Roaming (802.11d)

This controls whether the radio frequencies are set based on the radio configuration, or information from the access point it connects to. Disabled means the radio defaults are used. Flexible means the access point settings are used if present, but if not the radio default is used. Strict means the access point must provide regulatory frequency information..

```
SET NW IROAM [ DISable | STRICT | FLEXible ]
             (default = FLEXIBLE)
```

## SH NW IROAM NW IROAM

Shows what International Roaming setting is currently configured.

sample output:

```
International Roaming = Flexible
```

## SET NW DFS

### Dynamic Frequency Select (802.11h)

This controls whether the available radio frequencies are set based on the radio configuration, or information from the access point it connects to. Disabled means the radio defaults are used. Flexible means the access point settings are used if present, but if not the radio default is used. Strict means the access point must provide frequency control information...

```
SET NW DFS [ DISable | STRICT | FLEXible ]
            (default = DISABLED)
```

## SH NW DFS

Shows what Dynamic Frequency Select is currently configured.

sample output:

```
International Roaming = Flexible
```

## SET NW REGDOMain

This field displays the region of operation for which the wireless interface is intended. Note that the possible countries are pulled from the radio card and may differ depending on what card is used.

```
SET NW REGDOMain <country>
country = "xxx", where xxx =
  { "US " , REGDOM_TEXT_US },
  { "USI" , REGDOM_TEXT_US_INDOOR },
  { "AU " , REGDOM_TEXT_AUSTRALIA },
  { "AT " , REGDOM_TEXT_AUSTRIA },
  { "ATI" , REGDOM_TEXT_AUSTRIA_INDOOR },
  { "BE " , REGDOM_TEXT_BELGIUM },
  { "BEI" , REGDOM_TEXT_BELGIUM_INDOOR },
  { "CA " , REGDOM_TEXT_CANADA },
  { "DK " , REGDOM_TEXT_DENMARK },
  { "DKI" , REGDOM_TEXT_DENMARK_INDOOR },
  { "FI " , REGDOM_TEXT_FINLAND },
  { "FII" , REGDOM_TEXT_FINLAND_INDOOR },
  { "FR " , REGDOM_TEXT_FRANCE },
  { "FRI" , REGDOM_TEXT_FRANCE_INDOOR },
  { "DE " , REGDOM_TEXT_GERMANY },
```

```

{ "DEI" , REGDOM_TEXT_GERMANY_INDOOR },
{ "GR " , REGDOM_TEXT_GREECE },
{ "HU " , REGDOM_TEXT_HUNGARY },
{ "HK " , REGDOM_TEXT_HONG_KONG },
{ "IS " , REGDOM_TEXT_ICELAND },
{ "ISI" , REGDOM_TEXT_ICELAND_INDOOR },
{ "IN " , REGDOM_TEXT_INDIA },
{ "IE " , REGDOM_TEXT_IRELAND },
{ "IEI" , REGDOM_TEXT_IRELAND_INDOOR },
{ "IT " , REGDOM_TEXT_ITALY },
{ "ITI" , REGDOM_TEXT_ITALY_INDOOR },
{ "JP " , REGDOM_TEXT_JAPAN },
{ "JPI" , REGDOM_TEXT_JAPAN_INDOOR },
{ "JPO" , REGDOM_TEXT_JAPAN_OUTDOOR },
{ "LU " , REGDOM_TEXT_LUXEMBOURG },
{ "LUI" , REGDOM_TEXT_LUXEMBOURG_INDOOR },
{ "NL " , REGDOM_TEXT_NETHERLANDS },
{ "NLI" , REGDOM_TEXT_NETHERLANDS_INDOOR },
{ "NZ " , REGDOM_TEXT_NEW_ZEALAND },
{ "NO " , REGDOM_TEXT_NORWAY },
{ "NOI" , REGDOM_TEXT_NORWAY_INDOOR },
{ "CN " , REGDOM_TEXT_PRC },
{ "PT " , REGDOM_TEXT_PORTUGAL },
{ "PTI" , REGDOM_TEXT_PORTUGAL_INDOOR },
{ "PL " , REGDOM_TEXT_POLAND },
{ "SG " , REGDOM_TEXT_SINGAPORE },
{ "ES " , REGDOM_TEXT_SPAIN },
{ "ESI" , REGDOM_TEXT_SPAIN_INDOOR },
{ "SE " , REGDOM_TEXT_SWEDEN },
{ "SEI" , REGDOM_TEXT_SWEDEN_INDOOR },
{ "CH " , REGDOM_TEXT_SWITZERLAND },
{ "CHI" , REGDOM_TEXT_SWITZERLAND_INDOOR },
{ "TW " , REGDOM_TEXT_TAIWAN },
{ "GB " , REGDOM_TEXT_UK },
{ "GBI" , REGDOM_TEXT_UK_INDOOR }

```

## SH NW REGDOMain

Shows the region of operation for which the wireless interface is intended.

sample output:

```
Reg. Domain: US
```

## SET NW WIRED

Sets Ethernet Speed to 10baseT, 100baseTX, or Autosense.

```
SET NW WIRED [ AUTO | 10BASE | 100BASE ]
```

# Port Commands

## Serial Port Commands

### SH PORT

Shows Port parameters

sample output:

Port	Q-Size	Type	Attributes
*S1	0	serial	115200 N 8 1 XON/XOFF RS232

## SET PORT

Sets Parameters for specified port. The available commands are dependent on the port type.

### CLEAR PORT S1 JOB

This command aborts the currently active job on the port specified. If the remote host is still connected, any further data received will be discarded.

```
CL PORT S1 JOB
```

### SET PORT S1 FLOW

Set serial port flow control to NONE, XON/XOFF, CTS, or DSR

```
SET PORT S1 FLOW <flow>
(default = None)
```

### SET PORT S1 PARITY

Set serial port parity to NONE, EVEN, ODD, MARK, or SPACE

```
SET PORT S1 Parity <parity>
(Default = None)
```

### SET PORT S1 SIZE

Sets the data bits on the serial port

```
SET PORT S1 Signal [7 | 8]
(default = 8)
```

### SET PORT S1 SPeed

Sets serial port baud rate. Options for BAUD are 300, 600, 1200, 2400, 7200, 9600, 19200, 38400, 57600, 115200, 230400, and 460800

```
SET PORT S1 SPEED <baudrate>
(default = 115200)
```

### SET PORT S1 STOP

Sets serial port stop bits per character.

```
SET PORT S1 STOP [1 | 2]
(default = 1)
```

## Parallel Port Commands

### SH PORT

Shows Port parameters

sample output:

Port	Q-Size	Type	Attributes
*P1	0	parallel	BID ACKH NBUF

### SET PORT

Sets Parameters for specified port. The available commands are dependent on the port type. For EasyLAN Wireless Model AW02, the only port available is parallel port P1.

#### SET PORT P1 ACKH

Enable or disable pACK handshake (1284 compatible) mode. ECP and Fast Strobe mode must be disabled for compatibility mode to be used.

```
SET PORT P1 ACKH [ENABLE | DISABLE]
                (default = enable)
```

#### SET PORT P1 BIDir

Enable or disable bidirectional mode

```
SET PORT P1 BIDir [ENable | DISable]
                (default = enable)
```

#### SET PORT P1 ECP

Enable or disable 1284 ECP mode. If enabled, this mode takes priority over compatibility (ACKH) and fast strobe (FSTB) mode.

```
SET PORT P1 ECP [ENable | DISable]
                (default = enable)
```

#### SET PORT P1 FSTB

Enable or disable fast strobe mode. This mode handshake only with the busy line from the printer. If enabled, this mode take priority over the compatibility (ACKH) mode of operation.

```
SET PORT P1 FSTB [ENable | DISable]
                (default = disable)
```

#### SET PORT P1 INWT



Enable or disable input wait mode. If enabled, this mode delays polling for input from the printer at the end of a job for one poll period. If disabled, the printer is polled as soon as the last byte in the job is sent to it.

```
SET PORT P1 INWT [ENable | DIsable]
    (default = disable)
```

### **SET PORT P1 NBUF [ENable | DIsable]**

Enable or disable no buffer mode. If enabled, data is passed directly from the network to the printer without buffering. Depending on the network set up and application, buffering may improve performance or reduce it.

```
SET PORT P1 NBUF [ENable | DIsable]
    (default = enable)
```

### **SET PORT P1 NOINBUSY**

Enable or disable noinput while busy mode. If enabled, the printer will not be polled to see if it has data to send back to the host if it is reporting busy status on the interface.

```
SET PORT P1 NOINBUSY [ENable | DIsable]
    (default = disable)
```

### **SET PORT P1 POLL**

Set interval between input polls (msec). The value is meaningless if bidirectional mode is disabled.

```
SET PORT P1 POLL <nn>
    (default = 50 msec)
```

### **SET PORT P1 PSTA**

Enable or disable PJI status initialization.

```
SET PORT P1 PSTA [ENable | DIsable]
    (default = disabled)
```

### **SET PORT P1 SOJBUSY**

If the printer is busy when a print job is ready to start, this parameter determines how long the server waits after the printer becomes ready before starting to send data to it.

```
SET PORT P1 SOJBUSY <nn>
    (default = 100 msec)
```

### **CL PORT <port> JOB**

This command aborts the currently active job on the port specified. If the remote host is still connected, any further data received will be discarded.

```
CL PORT P1 JOB
```

## USB Port Commands

### SET PORT U1 PSTA

Enable or disable PJL status initialization.

```
SET PORT U1 PSTA [ENable | DIsable]
                (default = disabled)
```

### SET PORT U1 NBUF [ENable | DIsable]

Enable or disable no buffer mode. If enabled, data is passed directly from the network to the printer without buffering. Depending on the network set up and application, buffering may improve performance or reduce it.

```
SET PORT U1 NBUF [ENable | DIsable]
                (default = enable)
```

## Server Information Commands

### SET SERVER DDescription

Sets the server description string

```
SET SERVER DDescription <description-string>
```

### SET SERVER NName

Sets server node name

```
SET SERVER NName <name>
                (default = "SLXxxxxxx", where xxxxxx are the last 6 hex digits of
                the MAC address)
```

### SET SNMP GETCOMM

Get Community Name

```
SET SNMP GETCOMM <string>
    (default = "public")
```

## SET SNMP JETADmin

Enable or disable JetAdmin compatibility

```
SET SNMP JETADmin [ ENable | DIsable]
    (default = enabled)
```

## SET SNMP SETCOMM1

Set Community 1 Name

```
SET SNMP SETCOMM1 <string>
    (default = "internal?")
```

## SET SNMP SETCOMM2

Set Community 2 Name

```
SET SNMP SETCOMM2 <string>
    (default = "pass")
```

## SET SNMP CONTACT

Set system contact string

```
SET SNMP CONTACT <string>
    (default = <null>)
```

## SET SNMP LOCation

Set the system location string

```
SET SNMP LOCation <string>
    (default = <null>)
```

## SH SERIAL

Displays the serial number of the unit

sample output:

```
Serial number is 9047595
```

## SH SERVER

Shows Server parameters

sample output:

```
Serial Server Serial # 9047595
Address: 00-40-17-8A-0E-2B      Name: SLX8A0E2B      Number: 0
Identification: Network Server
Enabled Characteristics:
Link DOWN
```

## SH SERVER CO

Shows Server network statistics

sample output:

Seconds Since Zeroed:	163	Frames Sent, 1 Collision:	26
Bytes Received:	72950	Frames Sent, 2+ Collision:	5
Bytes Sent:	18726	Send Failures:	0
Frames Received:	752	Send Failure Reasons:	0
Frames Sent:	181	Receive Failures:	503
Multicast Bytes Rcv'd:	64474	Receive Failure Reasons:	1
Multicast Bytes Sent:	2406	Unrecognized Destination:	0
Multicast Frames Rcv'd:	626	Data Overrun:	0
Multicast Frames Sent:	11	User Buffer Unavailable:	0
Frames Sent, Deferred:	2014	System Buffer Unavailable:	1

## SH SNMP

Shows the state of the SNMP protocol enable

sample output:

```
SNMP is Enabled
```

## SH VErSION

Shows the print server's firmware version

sample output:

```
serial server
Firmware Ver. 4.19 (2004.10.31)
Boot Ver. 1.4
16Mbit Flash

Protocols supported:
NetBIOS SNMP TCP/IP EMail DHCP
```

## Zero

Clears and resets the network statistic counters

## Service Commands

### SET SERVI <service name> BOT

Set beginning of transmission (BOT) string index for service

```
SET SERVI <service name> BOT nn
      (default = 1)
```

### SET SERVI <service name> EOT

Set end of transmission (EOT) string index for service

```
SET SERVI <service name> EOT nn
      (default = 1)
```

### SH SERVI STRings [*string\_num*]

Defines the BOT and EOT strings used in services. If *string\_num* is provided then the specific string definition and expansion is displayed. If *string\_num* is not provided, then all string definitions (but not their expansions) are displayed.

sample output:

```
10: \FF\04\FF\05\FF\06\FF\08
```

### SET SERVI <service name> Filter

Set filter index for service

```
SET SERVI <service name> Filter nn
```

### SH SERVI FILTERs

Shows filter settings

sample output:

#	Service Name	Filter
1	SLX_FFFFFFFF	0: No Filter
2	BINARY_P1	0: No Filter
3	TEXT_P1	1: Text Substitution m= LF, r=
CRLF		
4	SLX_FFFFFFFF_P1_4	0: No Filter
5	SLX_FFFFFFFF_P1_5	0: No Filter
6	SLX_FFFFFFFF_P1_AT	4: PostScript Tagged Binary

### SET SERVI <service name> FMS

Set filter 1 (text replacement filter) match string index. If the index is zero, the default string of <LF> (line feed) is used.

```
SET SERVI <service name> FRM nn
      (default = 0 )
```

## **SET SERVI <service name> FRS**

Set filter 1 (text replacement filter) replace string index. If the index is zero, the default string of <CRLF> (carriage return-line feed) is used.

```
SET SERVI <service name> FRS nn
      (default = 0 )
```

## **SET SERVI <service name> IP**

Enable or disable all IP based jobs (lpd, raw tcp, ftp, etc.) on the service.

```
SET SERVI <service name> IP [ENable | DIsable]
      (default = enabled for service 1 and 2, disabled for all others)
```

## **SET SERVI <service name> NAME**

Change the service name

```
SET SERVI <service name> NAME <newname>
      (default varies by service)
```

## **SET SERVI <service name> PORT**

Set the output port associated with a service.

```
SET SERVI <service name> PORT <portname>
      (default = "S1")
```

## **SET SERVI <service name> PRIORITY**

Set priority for service if multiple service try to transmit data at the same time. Higher priority services are serviced first.

```
SET SERVI <service name> PRIORITY nn
      (default = 10)
```

## **SH SERVI PRI [*service\_num*]**

This shows the priority of a specific service. If *service\_num* is not provided, the priority of all services is listed.

---

## SET SERVI <service name> RECeive

Set receive only mode for a service. This option is rarely required, but some host applications do not operate properly if data is received back from the serial device.

```
SET SERVI <service name> RECeive [ENable | DISable]
      (default = disabled)
```

## SET SERVI <service name> TCP

Set raw TCP port for service. If port number is zero, raw TCP is disabled on that service.

```
SET SERVI <service name> TCP nn
      (default = 9100 for service 1, 3001 for service 2)
```

## SET SERVI <service name> QUEUE

If enabled, and if a raw TCP port is defined, the server will queue jobs sent to that port. If disabled, jobs will be rejected if the server is currently busy with another job.

```
SET SERVI <service name> QUEUE [EN | DIS]
      (default = disabled)
```

## SH SERVI SUMmary [*service\_num*]

Shows the basic parameters for a specific service. If *service\_num* is not provided, parameters for all services are displayed.

Note: The command SH SERVI is equivalent to SHOW SERVI SUM

## String Commands

These commands configure strings used with services and service filters.

### SET STRing

Set service string table entry. (Note, String 1-11 can not be set or changed).

```
SET STRing <string #> "value"
```

### CL STRing

Clears the service string table entry.

```
CL STRing <string #>
```

## SH STRing [*string\_num*]

Defines the BOT and EOT strings used in services. If *string\_num* is provided then the specific string definition and expansion is displayed. If *string\_num* is not provided, then all string definitions (but not their expansions) are displayed.

sample output:

```
1:
2: \1BE
3: \04
4: \1B%-12345X
5: @PJL
6: ENTER LANGUAGE=
7: PCL\0A
8: POSTSCRIPT\0A
9: \FF\04\FF\05\FF\06\FF\07
10: \FF\04\FF\05\FF\06\FF\08
11: \0C
```

## SH FILTERs

Shows the available filters which can be used to modify a job stream.

sample output:

```
#      Filter
0      No Filter
1      Text Substitution
2      AppleTalk
3      Text to PostScript
4      PostScript Tagged Binary
5      DC1 Special
```

## TCP/IP Commands

### SET IP ACcess

Allow or disallow access to a block of remote addresses

```
SET IP ACcess [EN | DI | ALL] aa.bb.cc.dd {MAsk ee.ff.gg.hh]
      (default = empty list)
```

### SET IP RANge

Allow or disallow access to a range of remote addresses

```
SET IP RANge [EN | DI | ALL] aa.bb.cc.dd {MAx ee.ff.gg.hh]
      (default = empty list)
```



---

## SH IP ACcess

Display current access list settings

Sample output:

```
All hosts permitted access
```

## SET IP ADdress

Set server IP address

```
SET IP ADdress aa.bb.cc.dd  
(default = 192.0.0.192)
```

## SET IP ARP ENable

Enable or disable setting of IP address with an ARP packet

```
SET ARP [ENable | DIsable]  
(default = enable)
```

## SET IP BAnner

Enable or disable printing of job banner on LPD jobs

```
SET IP BAnner [ENable | DIsable]  
(default = disable)
```

## SET IP CHKSUM

Enable or disable verification of the IP checksum on received packets

```
SET IP CHKSUM [ENable | DIsable]  
(default = enable)
```

## SET IP BOot

Number of tries for each enabled IP boot method, if not set to STATIC

```
SET IP BOot n  
(default = 3)
```

## SET IP ENable

Enable or disable all IP based protocols

```
SET IP [ENable | DIsable]  
(default = enable)
```

## SET IP FTIme

If enabled, the IP timeout is measured in seconds. If disable, the IP timeout is in minutes.

```
SET IP FTIme [ENable | DIsable]
            (default = disable)
```

## SET IP FTP

Enable or disable the FTP protocol

```
SET IP FTP [ENable | DIsable]
           (default = enable)
```

## SET IP HTTP

Enable or disable the HTTP protocol

```
SET IP HTTP [ENable | DIsable]
            (default = enable)
```

## SET IP KEepalive

Set interval at which TCP keepalive packets are sent on a connection, in minutes.

```
SET IP KEepalive n
            (default = 5 min)
```

## SET IP LPD

Enable or disable the LPD protocol

```
SET IP LPD [ENable | DIsable]
           (default = enable)
```

## SET IP MMethod

Set method of getting IP address

```
SET IP MMethod [ AUTO | BOOTP | RARP | DHCP | STATIC ]
              (default = AUTO)
```

## SET IP PIng

Send IP ping packets to test connection to remote host.

```
SET IP PIng aa.bb.cc.dd
```

## SET IP PRObe

---

Enable or disable TCP connection probes

```
SET IP PRObe [ENable | DIsable]
            (default = disable)
```

## SET IP RARp

Enable setting of default router and/or subnet mask based on the source of a RARP IP address set.

```
SET IP RARp nn
            nn: 0=both 1=no subnet, 2=no router, 3=neither (default = 0)
```

## SET IP REtry

Enable or disable LPD retry on incomplete job

```
SET IP REtry [ENable | DIsable]
            (default = disable)
```

## SET IP ROuter

Set the default router address

```
SET IP ROuter aa.bb.cc.dd
            (default = 0.0.0.0)
```

## SET IP SUBnet

Set the IP subnet mask

```
SET IP SUBnet aa.bb.cc.dd
            (default = 0.0.0.0)
```

## SET IP TCP

Enable or disable the raw TCP (9100) protocol

```
SET IP TCP [ENable | DIsable]
            (default = enable)
```

## SET IP TELnet

Enable or disable the TELNET protocol

```
SET IP TELnet [ENable | DIsable]
            (default = enable)
```

## SET IP TFTP

Enable or disable the TFTP protocol

```
SET IP TFTP [ENable | DIsable ]
            (default = enable)
```

## SET IP TImeout

Set TCP Inactivity timeout , in seconds if fast timeout is enabled, otherwise in minutes.

```
SET IP TImeout n
            (default = 1 minute)
```

## SET IP WIndow

Set TCP maximum window size in bytes

```
SET IP WIndow nn
            (default = 10240)
```

## SH IP

Shows TCP/IP related Parameters

sample output:

```
IP is enabled
IP address 192.0.0.192
Subnet mask 0.0.0.0
IP Gateway 0.0.0.0
            (set manually)
LPD banner disabled
LPD retries are disabled

Service      Port    TCP port
xxxxxx_S1_A  S1     9100
xxxxxx_S1_B  S1     3001
```

# Power Configuration Commands

## SET POWER DELAY nnnn

This is the time, in milliseconds, to wait before the processor goes into power save mode. If no I/O occurs on the network or from the attached peripheral within this time period, the processor will go into low power mode. The value must be between 0 and 1800000 (30 minutes). A value of 0 disables processor power saving. The default value is 0.

## SET POWER PERIOD nnnn

If radio power save is enabled, this the time, in milliseconds, between radio wake up events. The value must be between 1 and 65535. The default value is 65535.

## SET POWER WINDOW nnnn

This is the time, in milliseconds, the radio stays awake each time it wakes up in power save mode (i.e., every PERIOD msec the radio wakes up for WINDOW msec to see if there is traffic for it). The value is in the range 0-100. 0 disables radio power save mode (the CPU may still go into power save based on the DELAY parameter). The default is 0 (disabled).

---

## Firmware Update

These commands set up the unit for performing an update of the server firmware.

### SET LOAd ENable

If enabled, the firmware performs a soft reset and enters the server boot program after the next EXIT command. This command should not be used with the Serial Server. It remains in the firmware for diagnostic use.

```
SET LOAd (ENable | DIsable ]  
          (default = disable)
```

### SET LOAd HOst

Set the node name of the Netware boot host. Note that netware download is not supported on the Serial Server, so this command should not be used.

```
SET LOAd HOst      <name>  
          (default = <null>)
```

### SET LOAd IP

Set the IP address of the source computer for a TFTP get operation.

```
SET LOAd IP      aa.bb.cc.dd  
          (default = 0.0.0.0)
```

### SET LOAd SOftware

Set filename on host for TFTP get update.

```
SET LOAd Software <filename>
```

### SET LOAd TFTP

Initiate firmware update via a TFTP get operation. The TFTP server address must be set via SET LOAd IP and the filename via SET LOAd SOftware. The server will reset after the firmware update is completed.

```
SET LOAd TFTP
```

### SET LOAd XModem

Initiate firmare update via the serial console using the XModem protocol. The server will reset after the firmware update is completed.

```
SET LOAd XModem
```

---

## SH LOAd

Shows the firmware update parameters

sample output:

```
Firmware load is disabled
Load Host IP    = 0.0.0.0
Software file   = xxxx.bin
Load Host Name  =
```

## Other Commands

### SET DEFAULT

Set parameters to factory defaults

### EXIT

This command exits the current configuration console session.

```
EXIT
```

### SH FATal

Shows fatal error log (if there's any)

sample output:

```
No saved errors
```

### CL FATal

Clears the fatal error log

### SH FREE

Shows the amount of heap and configuration memory available

sample output:

```
2 bytes of heap available
Index 2, 6320 bytes
6320 bytes configuration memory available
```

### HElp <command>

This is for getting help on the console commands. You can just type help, or type help and then a command to display instructions on specific commands.

Sample output:

EXIT/^D	Exit program
HElp	Information on available commands
INititalize	Reset unit
CLear/PURge/DElete	Remove configuration item
SAVE	Save configuration to NV memory
SET/DEFine/CHange	Modify unit parameters
SHow	Display unit parameters
ZERo	Zero statistical counts

Type 'HElp <cmd>' for more information

### INIT



This command instructs the server to do a soft reset when the next exit command is executed.

```
INIT
```

## SET PAssword

Sets the server access (read) password

```
SET PAssword <password>  
    (default = "ACCESS")
```

## SET POWERON

Sets Power on delay

```
SET POWERON <delay-sec>  
    default == 0 (no delay)
```

## SH POWERON

Displays Power on delay in seconds

## SET PROTECT

Sets update password to the string given.

```
SET PROTECT <password>  
    (default = <null>)
```

## CL PROTECT

Sets update password to <null>.

```
CL PROTECT
```

## SAVE

This command saves the current configuration to non-volatile memory. Without this command, the configuration is not saved unless an "EXIT" command is performed.

```
SAVE
```

## SH TEst

Sends the configuration data via ASCII to the serial port

---

## UNPROTECT

If an update password has been defined (SET PROTECT), this command is used to enter the password to allow configuration items to be modified. After entering this command, the server will prompt for the update password. If entered properly, the user will then be able to execute SET commands to modify the server configuration. This lasts only until the console session is terminated with an EXIT command.

```
UNPROTECT
```

## Netware Commands

### SET NETW ADvertise

Advertising frequency in seconds

```
SET NETW ADvertise n
      (default = 60 sec)
```

### SET NETW ENable

Enable or disable the Netware Protocol

```
SET NETW [ENable | DISable]
      (default = enable)
```

### SET NETW FRame

Set Netware frame type

```
SET NETW FRame [802.2 | 802.3 | ETHer | AUto | SNAP]
      (default = AUTO)
```

### SET NETW NPrinter

Set NPrinter mode on service

```
SET NETW NPrinter <pserver> n ON <service>
```

### SET NETW PAssword

Set password for file server

```
SET NETW PAssword <psw>
      (default = <null>)
```

### SET NETW POLLing

Set Queue polling time in seconds

```
SET NETW POLLing n
      (default = 4)
```

## **SET NETW QServer**

Set QServer mode on service

```
SET NETW QServer <fileserver> ON <service>
```

## **SET NETW REscan**

Rescan Netware servers for new queues

```
SET NETW REscan
```

## **SET NETW SErver**

Enable or disable access to a server

```
SET NETW SErver <name> [ENable | DIsable]
```

## **CL NETW SErver**

Removes the specified Netware Server

```
CLear NETW SErver
```

---



---

## SH NETWare

Shows Netware Parameters

sample output:

```

Netware is Enabled
Enabled frame types AUTO
Queue polling frequency is 4 seconds
Advertising frequency is 60 seconds

Queue Servers                                Bindery File Servers
PR1                                           None

      Frame type      Network      Count
      Ethernet II    Unknown     8
      IEEE 802.2      Unknown    408
*     IEEE 802.3      000E8023  4967
      Ethernet SNAP   Unknown     6

Servers and Queues being serviced

Servicing 0 queues on 0 file servers

0 jobs printed

```

## Email Printing Commands

### SET POP3 Address

Set POP3 Server IP address

```

SET POP3 Address aa.bb.cc.dd)
      (default = 0.0.0.0)

```

### SET POP3 ENable

Enable or disable the POP3 Protocol

```

SET POP3 [ENable | DISable]
      (default = enable)

```

### SET POP3 POLLing

Set frequency to poll POP3 server for jobs, in seconds.

```

SET POP3 POLLing nn
      (default = 30 sec)

```

### SET POP3 NAmE

Set POP3 Mailbox from which to fetch email jobs.

```
SET POP3 NAmE <name>  
    (default = <null>)
```

## SET POP3 PAssword

POP3 Mailbox password

```
SET POP3 PAssword <password>  
    (default = <null>)
```

## SET POP3 TImeout

Set POP3 Message timeout in minutes

```
SET POP3 TImeout nn  
    (default = 120 min)
```

## SET SMTP ADdress

SMTP Server IP address

```
SET SMTP ADdress aa.bb.cc.dd  
    (default = 0.0.0.0)
```

## SET SMTP ENable

Enable/Disable SMTP Protocol

```
SET SMTP [ ENable | DISable ]  
    (default = enabled)
```

## SH POP3

Shows POP3 Parameters

sample output:

```
Internet Printing Configuration:

POP3 Server      0.0.0.0
POP3 Mailbox
POP3 Polling     30 seconds
POP3 Timeout     120 minutes
POP3 Total Messages  0
POP3 Total Connects  0
POP3 Connect Failures 0
POP3 Connections Lost 0
POP3 User Failures 0
POP3 Password Failures 0
POP3 Total I/O Errors 0
SMTP Server      0.0.0.0
SMTP Total Messages  0
SMTP Total Connects  0
SMTP Connect Failures 0
SMTP RecdFrom Failures 0
SMTP SentTo Failures 0
```

## SH SMTP

Shows SMTP Parameters. This displays the same output as SHOW POP3.

## DLC / NETBEUI Commands

### SET DLC ENable

Enable/Disable DLC Protocol

```
SET DLC [ ENable | DISable ]
      (default = enable )
```

### SET DLC TIMEout

Set DLC timeout in seconds, 0 disables the timeout

```
SET DLC TIMEout  nn
      (default = 0)
```

## SH DLC

Shows DLC Parameters

sample output:

```
DLC is Enabled
DLC timeout      30 seconds
```

## SET NetBEUI ENable

Enable/Disable NetBEUI Protocol

```
SET NETBEUI [ ENable | DISable ]  
            (default = enable)
```

## SET NETBIOS DOMain

Set the NETBIOS domain name

```
SET NETBIOS DOMain <name>  
            (default = <null>)
```

## SET NETBIOS MMethod

Set method of getting WINS server address

```
SET NETBIOS MMethod [ AUTO | STATIC ]  
            (default = AUTO)
```

## SET NETBIOS PRimary

Set the IP address of primary WINS server

```
SET NETBIOS PRimary aa.bb.cc.dd
```

## SET NETBIOS SEcondary

Set the IP address of secondary WINS server

```
SET NETBIOS SEcondary aa.bb.cc.dd
```

# Appletalk Commands

## SET APPIetalk

Enables or Disabled Appletlak Protocol

```
SET APPIetalk [EN | DI]  
            (default = enabled)
```

## SET APPIetalk ZONE

Configures the Appletalk Zone for this server

```
SET APPIetalk ZONE <name>  
            (default = none)
```

---

## Wireless Security Configuration

silex products support various methods of authentication and encryption to ensure compatibility with wireless security deployments. This document describes how to configure wireless security on silex print servers and device servers.

silex offers a variety of ways to configure the security parameters, including the ExtendView utility for Windows systems, a built-in web browser interface, and a command line console (described at the end of this document).

---

### ExtendView

Note: You must be using ExtendView version 2.4 or later in order to configure wireless security settings. Install the ExtendView utility (found on the installation CD or at [www.silexamerica.com](http://www.silexamerica.com)). Select the product you want to configure from the list, click Server, and then Configuration and follow these steps for configuration:

1. Click on the Wireless tab.
2. Select Infrastructure for the Wireless mode and type in the correct SSID.
3. Click Configure Wireless Security.

---

### Web Browser Interface

Open any web browser from your PC (eg: Internet Explorer or Firefox) and type the IP Address of the print server for the Address. Click Login from the main menu in the left frame, and type in the password (default is ACCESS) and follow these steps for configuration:

1. Click on Wireless from the main menu in the left frame.
2. Select Infrastructure for the Wireless mode and type in the correct SSID.
3. Click Submit.
4. On the Configure Wireless screen, click on Configure Network Security.

---

### Web Browser Interface and ExtendView Security Configuration

You should now be able to enter the security settings whether you are in ExtendView or the web browser interface. See below for detail on each field in the form. Help is also available within the ExtendView utility or the web browser. If you are using ExtendView, click OK when you are done for the settings to take effect. If you are using the web browser interface, click submit when you are done, and click the link in the lower right frame to reset it and have the settings take effect.

### Encryption Mode

Select the desired encryption mode for the wireless link:

- 64 and 128 bit WEP are for basic security compatibility
- Dynamic WEP is displayed if an EAP (802.1x) method which automatically sets keys is selected as the authentication type.



- WPA uses TKIP encryption.
- WPA2 uses CCMP encryption.
- WPA2-WPA uses CCMP for pair-wise encryption, but allows TKIP for group encryption.

**Key Selection**

If WEP encryption is selected, and the authentication mode is not an EAP (802.1x) mode, select the desired WEP key to be used, one through four.

**WEP Key**

These fields are ignored unless the encryption mode is 64 or 128 bit WEP. Enter up to 10 hexadecimal digits for 64 bit WEP, or 26 hexadecimal digits for 128 bit WEP.

**Authentication Type**

Choose type of authentication to be performed with the network access point, or with a peer unit in Ad-hoc mode.

**User ID**

Enter the logon user ID that the server uses to authenticate to the 802.1x-enabled network. The user ID and password must be in the authentication server database, and is used in TTLS, LEAP, and PEAP configurations. The default user ID is 'anonymous'. A realm defines a grouping of users. If a realm is required for your network, it is separated from the user ID by a '@' character. Realms make it easier to segregate user groups into independently administered databases, to apply policies on a user group basis, and to establish roaming agreements to name a few applications. The default realm if not specified is 'anonymous'. Realm is used with TTLS configurations, and sometimes with PEAP.

**Password**

Enter the logon password that the server uses to authenticate to the 802.1x enabled network. The user ID and password must be in the authentication server database, and is used in TTLS, LEAP, and PEAP configurations. The password may be a text string, or a string of hex bytes prefixed with '\x'. The default password is 'anonymous'.

**Certificate Common Name**

Enter the name of the certificate on the primary authentication server. If both of the common names are set to null, all certificates are accepted. The default is null. Certificate common name is used in TTLS and PEAP configurations.

**Certificate Root Key**

Enter the authentication key used to verify the root certificate in the certificate chain provided by the authentication server. To set to null, leave this field blank. Certificate Root Key is used in TTLS and PEAP configurations. The Certificate Root Key can be extracted by clicking Browse and selecting the actual certificate if you don't want to type it in manually.

**Certificate Root Key Exponent**

This value must match the authentication server certificate value. The default is 65537 (x10001). Certificate Root Key Exponent is used in TTLS and PEAP configurations. The Certificate Root Key Exponent can be extracted by clicking Browse and selecting the actual certificate if you don't want to type it in manually.

**Authentication Protocol**

This field determines how the server authenticates itself to the 802.1x enabled network after an 802.1x session is established. The default is PAP. Sometimes referred to as inner-authentication protocol, it is used in TTLS and PEAP configurations.

**Pre-Shared Key**

If the PSK mode of authentication is selected with WPA (TKIP) or WPA2 (CCMP) encryption, the key value or pass-phrase entered here is used to initialize the session with the access point. If a key value is entered, it must be exactly 64 hex characters. A pass-phrase must be 8 to 63 displayable characters.

**WPA Auto Associate**

If the WPA Auto Associate mode is enabled, then if there are no WPA enabled access points available with the given SSID, the unit will attempt to associate with a non-WPA access point with the given SSID, if available. The authentication mode will still have to match. For WPA-EAP, the non-WPA AP will have to be configured for EAP authentication, and for WPA-PSK mode, the non-WPA AP will have to be in open system mode. The default is disabled.

**WPA Group Key**

If the WPA Group Key mode is enabled, then group keys may be used for data link encryption. The default is disabled.

---

**Command Line Console Configuration**

Go to the command prompt on your PC and type TELNET ipaddress (where ipaddress is the IP Address configured in the print server). You should get a # prompt, type in the password (default is ACCESS, this will not echo on your screen as you type it). Hit Enter a couple times until you get a Local> prompt. This is where you can type your commands. Type HELP to get a list of commands.

The following console commands can be used to configure your network security settings:

**SH NW**

Displays summary network information

sample output:

```
WiFi Mode = INFRASTRUCTURE
WiFi SSID: silex
Speed = 11
Regulatory Domain = 704
WiFi FW Ver = 1F 1.7.1
AP density = LOW
TTLS is Disabled
WEP is Disabled
Link DOWN
```

**SET NW AUTHtype**

Sets WLAN Authentication type

SET NW AUTHtype [OPEN | SHARED | TLS | TTLS | LEAP | PEAP | PSK]  
(default = Open System)

**SH NW AUTH**

Shows the wireless authentication type

sample output:

```
Authentication type= OPEN SYSTEM
```

**SET NW CHannel**

Sets WLAN ad-hoc channel number

SET NW CHannel n  
n = 1-11 (default = 11, this value is ignored in Infrastructure mode)

### **SET NW ENC**

Sets WLAN Encryption Mode. Supported modes are none, 64 bit WEP, 128 bit WEP, WPA (TKIP), and WPA2 (AES/CCMP).

SET NW ENC [Disable | 64 | 128 | WPA | WPA2 ]  
(default = Disable)  
SH NW ENC

Shows the wireless encryption mode

sample output:  
encryption is Disabled

### **SET NW KEY#**

Selects WLAN WEP key entry

SET NW KEY# n  
n = 1-4 (default = 1)

### **SET NW KEYVAL**

Sets the currently selected WLAN WEP key entry to the hex value given.

SET NW KEYVAL <key>  
key=10 or 26 hex characters (default=<null>)

### **SET NW MOde**

Sets WLAN mode

SET NW MOde <mode>  
[Infrastructure | Ad-Hoc] (default = Infra)

### **SH NW MODE**

Shows the wireless operating mode

sample output:  
Wifi mode = AD-HOC (802.11)

### **SH NW RADio**

Shows the selected radio mode of operation

sample output:  
Radio mode is 802.11b

### **SET NW SPeed**

Sets maximum WLAN speed

**SET NW SPeed n**

n = 1,2,5.5 or 11 (default = 11) for 802.11b products

n = 1,2,5.5,6,9,11,12,18,24,36,48,54 (default = 54) for 802.11a/b/g

**SH NW SPEED**

Show the maximum wireless data speed in megabits per second

sample output:

Speed = 11

**SET NW SSid**

Sets WLAN SSID

SET NW SSid <name>

User defined (default = printer)

**CL NW SSid**

Clears the SSID value so the server will connect to any AP.

CL NW SSid

**SET NW BSsid**

Sets WLAN BSSID (connect to a specific access point's mac address)

SET NW BSsid <value>

User defined (MAC Address)

**CL NW BSsid**

Clears the BSSID value so the server uses just SSID and not a specific AP.

CL NW BSsid

**SET NW RTS**

Sets WLAN RTS threshold

SET NW RTS n

n = 1-3000 (default = 2432)

**SH NW RTS**

Shows the configured wireless RTS threshold

sample output:

Wifi RTS Threshold = 2432

**SET NW APDEN**

Sets WLAN Access Point Density

**SET NW APDEN** [LOW | MED | HI]  
(default = LOW)

**SH NW APDEN**

Shows the access point density

sample output:  
AP Density = Low

**SH NW STATS**

Show the network I/O statistics

sample output:  
WiFi statistics:  
TX Unicast frames: 0  
TX Multicast frames: 0  
TX Fragments: 0  
TX Unicast octets: 0  
TX Multicast octets: 0  
TX Deferred: 0  
TX Single retry frames: 0  
TX Multiple retry frames: 0  
TX Retry limit exceeded: 0  
TX Discards: 0  
RX Unicast frames: 0  
RX Multicast frames: 0  
RX Fragments: 0  
RX Unicast octets: 0  
RX Multicast octets: 0  
RX FCS errors: 0  
RX Discards no buffer: 0  
TX Discards wrong SA: 0  
RX Discards WEP undecr: 0  
RX Msg in msg fragments: 0  
RX Msg in Bad msg fragments: 0

**SET NW CERTCN**

Sets EAP Common Name

SET NW CERTCN <name>  
User defined (default=<null>)

**SH NW CERTCN**

Shows the value of the first common name check string

sample output:  
Common name 1

Note: the default for this string is a null (blank) string  
Note: The deprecated command SH NW TTCN will also return this information.

**SET NW CERTCN2**

---

Sets second EAP Common Name

SET NW CERTCN2 <name>  
User defined (default=<null>)

### SH NW CERTCN2

Shows the value of the second common name check string

sample output:  
Common name 2

Note: the default for this string is a null (blank) string

### SET NW CERTEXP

Sets EAP Certificate Exponent value

SET NW CERTEXP <exponent>  
User defined (default = 10001 Hex)

### SH NW CERTEXP

Shows the value of the certificate exponent

sample output:  
65537 (10001h)

Note: The deprecated command SH NW TTEXP will also return this information.

### SET NW CERTKEY

Sets EAP Root Key

SET NW CERTKEY <key value>  
User defined

### SET NW ID

Sets Authentication User ID. This may include the realm, separated by a '@' character.

SET NW ID <user id>  
(default = anonymous)

### SH NW ID

Shows the value of the authentication ID (including realm, if present)

sample output:  
anonymous@somewhere

Note: The default realm is a null (blank) string

Note: The deprecated command SH NW TTID will also return this information.

### SET NW PW

Sets the password used for the 802.1x EAP authentication, if enabled.

SET NW PW <password>  
(default = anonymous)

### **SET NW INAP**

Sets EAP Inner-Authentication protocol

SET NW INAP [PAP|MSCHAP\_V2]  
(default = PAP)

### **SH NW INAP**

Shows the selected inner authentication mode

sample output:  
Authentication protocol = PAP

Note: the deprecated command SH NW TTAP will also return this information.

### **SET NW REALM**

Sets the realm portion of the 802.1x EAP authentication ID This may also be set with the ID command.

SET NW REALM <realm>  
(default = <null>)

### **SH NW REALM**

Shows the realm associated with the authentication ID, if any.

sample output:  
somewhere

Note: The default realm is a null (blank) string  
Note: The deprecated command SH NW TTRE will also return this information.

### **SET NW WPAAUTO**

Enable or disable WPA/WPA2 auto mode. If enabled, the print server will connect to a non-WPA access point if a WPA enabled access point is not available. Only valid when WPA is enabled (authentication type = TKIP).

SET NW WPAAUTO [ENable | DIsable]  
(default = disabled)

### **SH NW WPAAUTO**

Shows the state of the WPA/WPA2 auto connect flag

sample output:  
WPA-AUTO Enabled

### **SET NW WPAGROUP**

---

Enable or disable WPA/WPA2 group key mode. If enabled, this allows group keys to be used for data link encryption.

SET NW WPAGROUP [ENABLE | DISABLE]  
(default = disabled)

### **SH NW WPAGROUP**

Shows the state of the allow WPA/WPA2 group keys flag

sample output:  
WPA-GROUP Disabled

### **SET NW WPAPSK**

Sets the WPA/WPA2 PSK pass phrase or hex key. This value is only used if the authentication mode is WPA-PSK. The argument to this command is either a pass phrase of 8-63 characters, or exactly 64 hex characters representing the 256 bit PSK value.

SET NW WPAPSK <key>  
(default = "silex")

### **SET NW WPATRACE**

Sets the WPA trace level. note: this command is for diagnostic purposes only, and should not normally be used as the trace can affect performance. A value of 0 disables the trace.

SET NW WPATRACE nn  
(default = 0)