

KIT AERO SYSTEM

XATLIN

Series 2
EASY SET

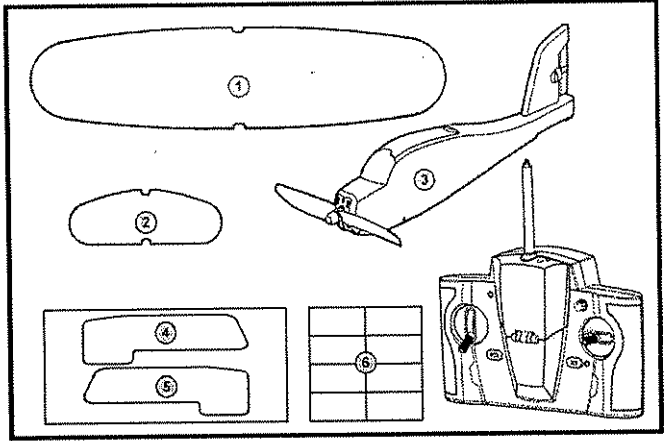

How to assemble / Montageanleitung / Comment assembler / Hoe in elkaar steken / Instrucciones de montaje

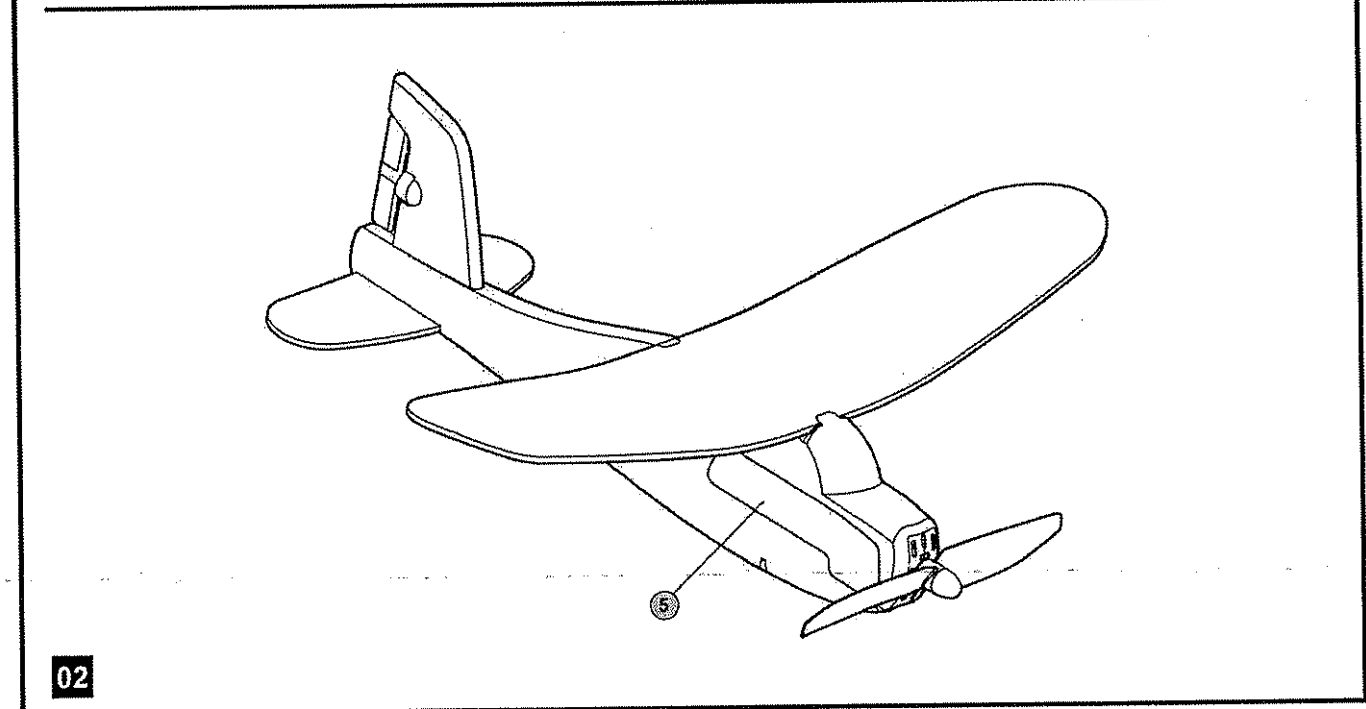
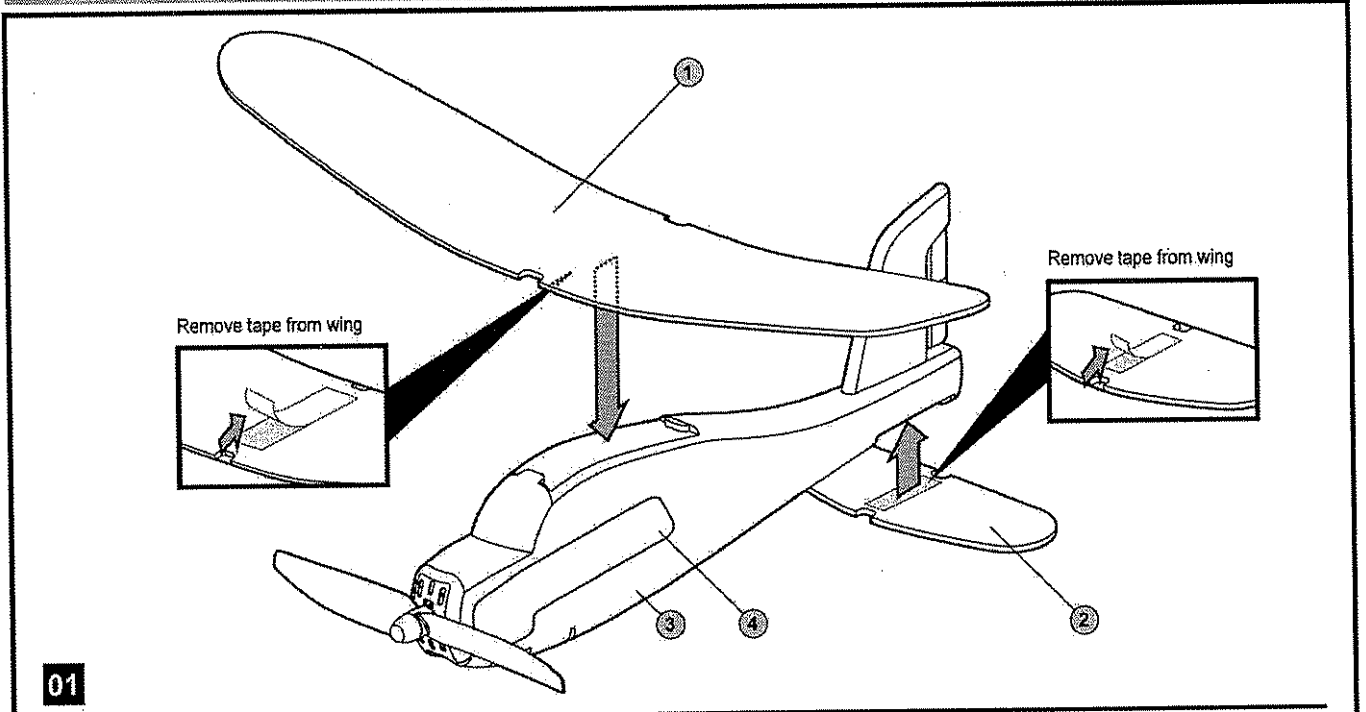

Key Features:

- Full Function Digital Proportional Radio Control
- Sell Assembly Model Kit
- Step By Step Assemble Manual

"This product is in compliance with the essential requirements and other relevant provisions of Directive 1999/5/EC."



Safety Precautions:

- Warning:** Changes or modifications to this unit not expressly approved by the party responsible for compliance could void the user's authority to operate the equipment.
- Keep hands, hair and loose clothing away from the propeller when power switch is turned ON.
 - Turn off transmitter and X-Twin when not in use.
 - Remove battery from transmitter when not in use.
 - Parental guidance is recommended for the flight.
 - Keep your plane in your sight so that you can supervise it all the time.
 - New and alkaline batteries are recommended for use in transmitter to obtain best and maximum performance.
 - You are advised to replace with new batteries as soon as the function becomes impaired.
 - Users should keep and retain this information for future reference.
 - Users should keep strict accordance with the instruction manual while operation the product.
 - Your Transmitter charger is tailor-made for the Li-Poly rechargeable battery used in plane. Do not use it to charge any battery other than that in the plane.
 - The wires are not to be inserted into socket-outlets.

FCC Statements

This device complies with part 15 of the FCC rules. Operation is subject to the following two conditions:
 1) This device may not cause harmful interference, and
 2) This device must accept any interference received, including interference that may cause undesired operation.

NOTE: This equipment has been tested and found to comply with the limits for a Class B digital device, pursuant to Part 15 of the FCC Rules. These limits are designed to provide reasonable protection against harmful interference in a residential installation. This equipment generates, uses and can radiate radio frequency energy and, if not installed and used in accordance with the instructions, may cause harmful interference to radio communications. However, there is no guarantee that interference will not occur in a particular installation. If this equipment does cause harmful interference to radio or television reception, which can be determined by turning the equipment off and on, the user is encouraged to try to correct the interference by one or more of the following measures:

- Reorient or relocate the receiving antenna.
- Increase the separation between the equipment and receiver.
- Connect the equipment into an outlet on a circuit different from that to which the receiver is connected.
- Consult the dealer or an experienced radio/TV technician for help.

WARNING:
CHOKING HAZARD - Small parts
Not for Children under 3 years.



WEEE

When this appliance is out of use, please remove all batteries and dispose of them separately. Bring electrical appliances to the local collecting points for waste electrical and electronic equipment. Other components can be disposed of in domestic refuse.



Do not touch the running propeller!
Do not play above someone's head!
Adult supervision is required!

Battery Cautions:

- Non-rechargeable batteries are not to be recharged
- Rechargeable batteries are to be removed from the toy before being charged (Transmitter only).
- Rechargeable batteries are only to be charged by an adult
- Different types of batteries or new and used batteries are not to be mixed (Transmitter only).
- Only batteries of the same or equivalent type as recommended are to be used.
- Batteries are to be inserted with correct polarity.
- Exhausted batteries are to be removed from the toy (Transmitter only).
- The supply terminals are not to be short-circuited.

Your plane is equipped with a Li-Poly battery, please also pay attention to the following cautions for safety use:

- Do not dispose the battery in fire or heat.
- Do not use or leave the battery near a heat source such as fire or heater.
- Do not strike or throw the battery against hard surface.
- Do not immerse the battery in water, and keep the battery in a cool dry environment.
- When recharging, only use the battery charger specifically for that purpose.
- Do not over-discharge the battery.
- Do not connect the battery to an electrical outlet.
- Do not directly solder the battery and pierce the battery with a nail or other sharp object.
- Do not transport or store the battery together with metal objects such as necklaces, hairpins etc.
- Do not disassemble or alter the battery.
- Charge the battery every 6 months.
- Turn off your equipment power switch after use.
- As for a used battery, please recycle after covering the battery terminals with insulation tape or inserting it to an individual poly-bag.

Care and Maintenance:

- Always remove batteries from the toy when it is not being used for a long period of time. (For transmitter only)
- Wipe the toy gently with a clean damp cloth.
- Keep the toy away from direct heat.
- Do not submerge the toy into water that can damage the electronic assemblies.

Note:

- Parental guidance is recommended when installing or replacing batteries.
- Under the environment with electrostatic discharge, the sample may malfunction and require user to reset the sample.

Special Note to Adults:

- Regularly examine for damage to the plug, enclosure and other parts. In the event of any damage, the toy must not be used with the transmitter charger until the damage has been repaired.
- This toy is not intended for children under 3 years old.
- This toy must only be used with the recommended charger
- Do not try to charge other batteries with transmitter Charger.

Battery requirement for X-Twin:

Power Supply :
 Rating : DC 3.7 V, 2 W
 Batteries : 1 x 3.7 V Li-Poly Rechargeable Battery Pack
 Requires 1 x 3.7 V Li-Poly Rechargeable Battery Pack (included)

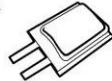

Battery requirement for Transmitter:

Power Supply :
 Rating : DC 9 V, 4 W
 Batteries : 6 x 1.5 V "AA"/LR6/AM3
 Requires 6 x 1.5 V "AA" size batteries (not included)



Silverlit Toys (U.S.A.) 20803 Valley Blvd., Suite #109, Walnut, CA. 91789
 ©2007 Silverlit Toys Manafactory Limited. All rights reserved.

Parts Index

Plane

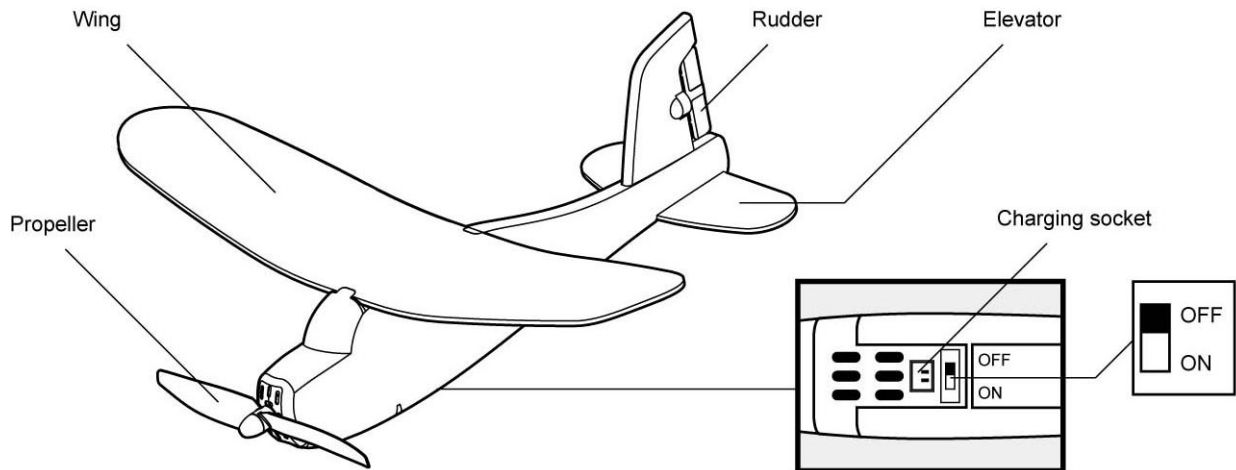

Transmitter

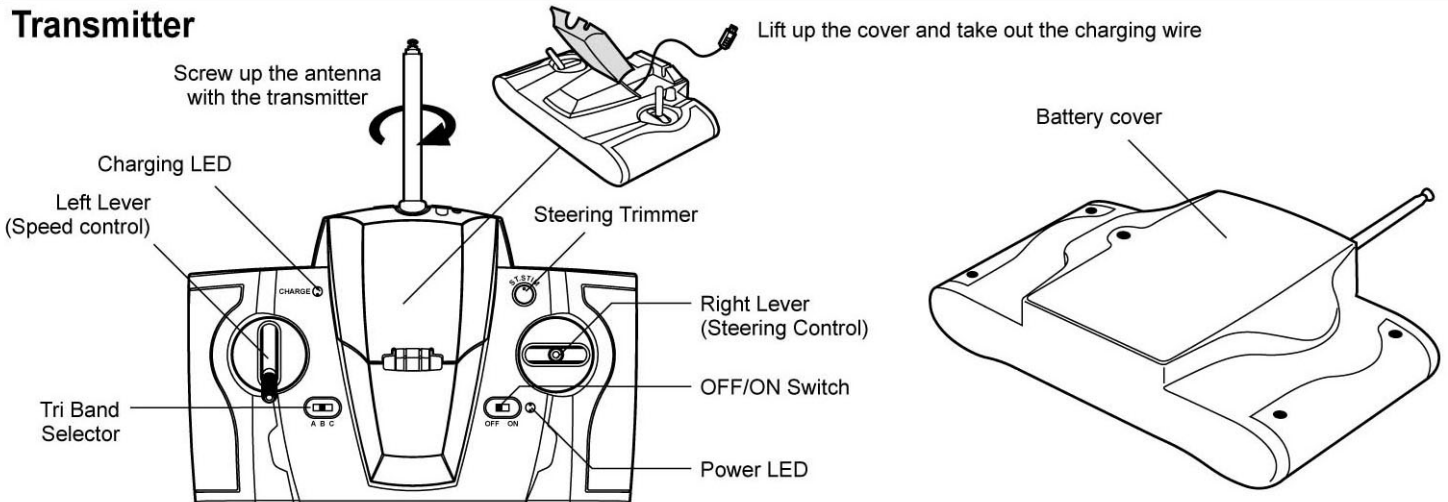

Flying Preparation

Battery Installation - Transmitter

Make sure the power switch is on "OFF" position.

1. Use a screwdriver to loosen screw on the battery case in anti-clockwise.
2. Put 6 AA size batteries in the battery compartment as per the polarity shown inside.
3. Tighten the screw in clockwise.

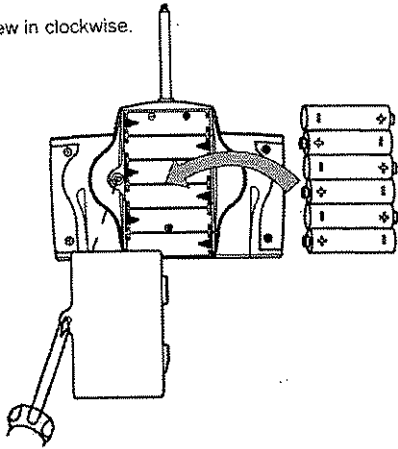

Battery Charging - Plane

IMPORTANT!

Turn off the power of plane before charging.

1. Put the plug on the transmitter in the socket on the plane. (pic.A)
2. The green LED will light up. (pic.B)
3. The green LED will turn off when the battery is fully charged.
4. It may take up to 30 minutes to fully charge the battery and a fully charged battery can serve about 5 minutes flight. The charging times may vary as to the battery status because your charger has intelligent charging control.

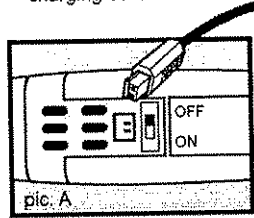

The green LED will light up when the plane is being charged.

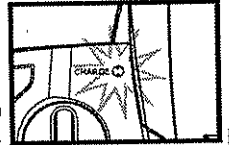

Playground and Weather selection

- Outdoor: It's better in a sunny day, and in calm wind or slight breeze (Esp. no more than Beaufort scale 1 - light air [smoke can float but leaf can't move].)
Precaution: Because of its light weight, it may be blown away under strong wind.
- We suggest you can play it on grass to protect your plane when it impacts on ground.
- Do not play your plane when it is raining, snowing, or near high power cable.

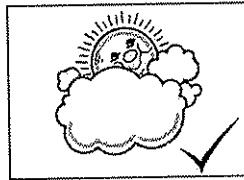

Flying your Plane

1. Screw in the antenna on transmitter.
2. Set the band on transmitter the same to the plane.
3. Set the ON/OFF switch on Plane to ON. BE SURE THE TRANSMITTER IS "OFF" when turn on the Plane.
4. Set the left lever on transmitter to MINIMUM throttle, then set it to ON.
5. Make sure the plane can go nearly straight:
Set the right lever on transmitter in its neutral position, then push the throttle in the middle to drive the plane and hand throw the plane out to see its flying trend. Please tune the steering trimmer to left when the plane has the trend to right (pic.1) or tune trimmer to right when it goes left (pic.2). Repeat the above steps several times to make your plane go straight.

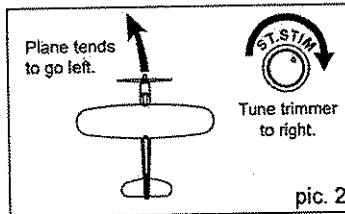
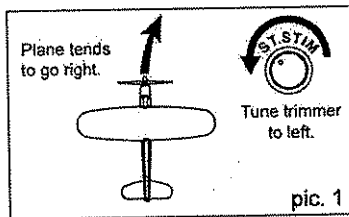

Repeat the above steps several times to make your plane go straight.

6. Be sure to let the plane face to the wind when you throw it. Also it is important that you should throw it horizontally.

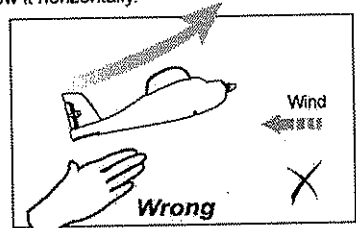
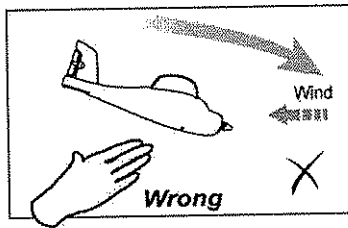
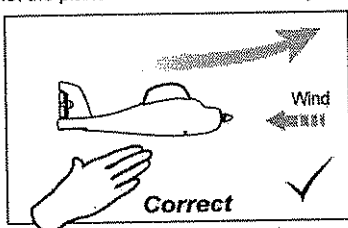

7. Set the right lever in its neutral position, then push the throttle to MAXIMUM to drive the plane and hand throw the plane out for flight.

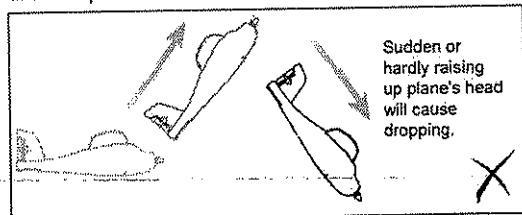
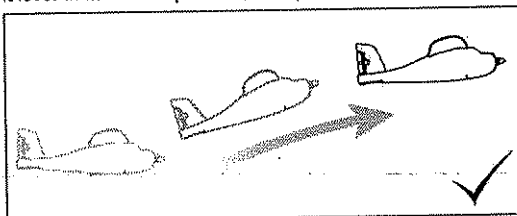







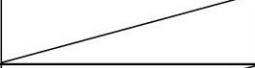

a) The correct flight pattern would be:

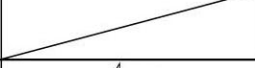
- b) If the plane raises its nose very quickly, it may fly near stalling speed and fall down. You should pull the left lever down (throttle down) to let it fly in horizontally.

ENGLISH

8. When your plane can fly steadily, you can move the right lever to left or right so that it can turn to left or right. You may need to strike but not hold the right lever for easy adjustment. The "turning" function depends on the running speed variation between left and right propeller, please note that if the plane response slowly to your command, you should throttle up for better performance.
9. Landing: Turn your plane facing the wind, then throttle down.
10. The table shown on the right gives you a rough idea of the relation between transmitter operating and the plane response.
11. If your plane has minor damage, you can fix it with pressure sensitive tape.
12. The plane may be abnormal after crashes, improper storage ...etc. you can follow the following procedure to get better flight, cut the airfoil along the line and tune it as the below picture.

Left Lever (Speed control)	Right Lever (Steering control)	Action
		 Take off and Go up
		 Go down and land
Stability of fly		 Turn left
Stability of fly		 Turn right

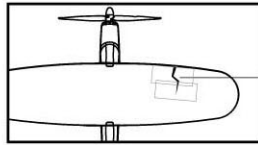

⑥

Tape

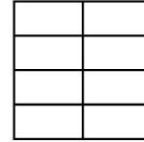

Label For
Repair

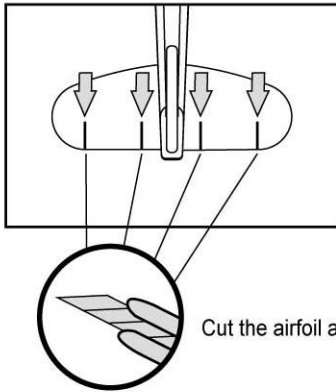

Caution:
For cutting airfoil by cutter, all trimming action will be completed by an adult.



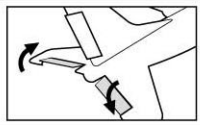
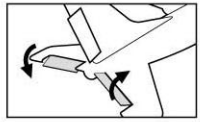



Cut the airfoil along the line.

Symptom	Correction
Turn right and go down suddenly.	
Turn left and go down suddenly.	

Trouble Shooting

Symptom	Cause	Correction
Propeller can't move	- ON/OFF Switch is OFF. - Weak Battery.	- Set switch to ON. - Re-charge the battery pack.
R/C Plane turns around and descends after taking off	- Trimmer is not tuned properly.	- Adjust the trimmer.
Can't take off or drop down at flight	- Plane doesn't run to the wind before taking off. - Weak power. - Flying at the wrong elevator angle or speed.	- Let the plane run to the wind before taking off. - Re-charge the battery pack. - Play for more skills, such as tune the Throttle Trimmer for precise power control or stroke (not hold) the left control lever on transmitter.
Drop down at the climbing state or before take off	- Weak power. - Large upper angle of elevator.	- Re-charge the battery pack. - Re-tune the elevator.
Plane does not react, or react poorly to operation by transmitter.	- High-frequency interference occurred near to high-voltage lines, transformers and some types of building.	- Avoid these if possible, or choose another place to operate the plane.
Loss of control.	- Another radio control R/C plane using the same frequency and channel is operated near your R/C Plane. - Out of the control range of distance.	- Move to another place where without radio frequency interference from another device. - Ensure the antenna is fully extended. The R/C Plane flyup to 50 meters in open space.

DIY Series

Product Series	DIY Series 2	DIY Series 3	DIY Series 5		DIY Series 7	DIY Series 9
Product Code	85762	85763	85765	85766	85780	85682
Plane Type						
Level Of Technique	Easy		Medium		Advance	
Propeller	1 - Propeller	2 - Propeller	2 - Propeller		2 - Propeller	4 - Propeller
Motor Size	Dia. 6 mm x 1	Dia. 6 mm x 2	Dia. 6 mm x 2		Dia. 7 mm x 2	Dia. 6 mm x 4
Battery Power	130 mAh (Built-in)	130 mAh (Built-in)	130 mAh Battery Pack (Black color)		130 mAh Battery Pack (Blue color)	
Channel	Built-In Tri-Band System			With Tri-Band Selection System		
RX Module	Built-In RX Module	Standard RX Module	Semi Assembly & Upgradable RX Module		Semi Assembly & Hi-Power Driven RX Module	