

Driving the remote controlled vehicle

1. Extend the antenna on transmitter.
2. Set transmitter power switch to "ON", the power indicator will light up.
3. Set vehicle power switch to "ON".
4. Set transmitter and vehicle to the same band.
5. Steer the vehicle by adjusting the throttle stick and steering stick of transmitter in different combinations to perform different action.
6. Press the light button on transmitter to trigger the lighting.
7. Turn the steering axle adjuster at the bottom towards "L" when the vehicle drives to the right involuntarily. If it turns left involuntarily, turn the adjuster towards "R".

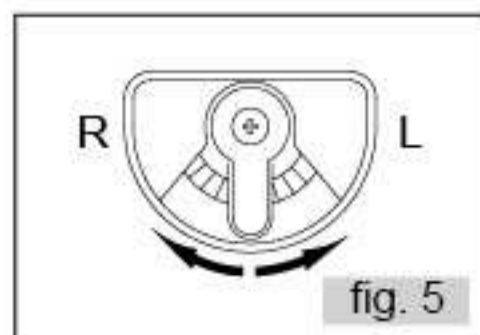

Steering

Throttle stick	Direction stick	Movement
↑	→	Forward and accelerate
↓	→	Backward and accelerate
↑	←	Forward left
↑	→	Forward right
↓	←	Backward left
↓	→	Backward right

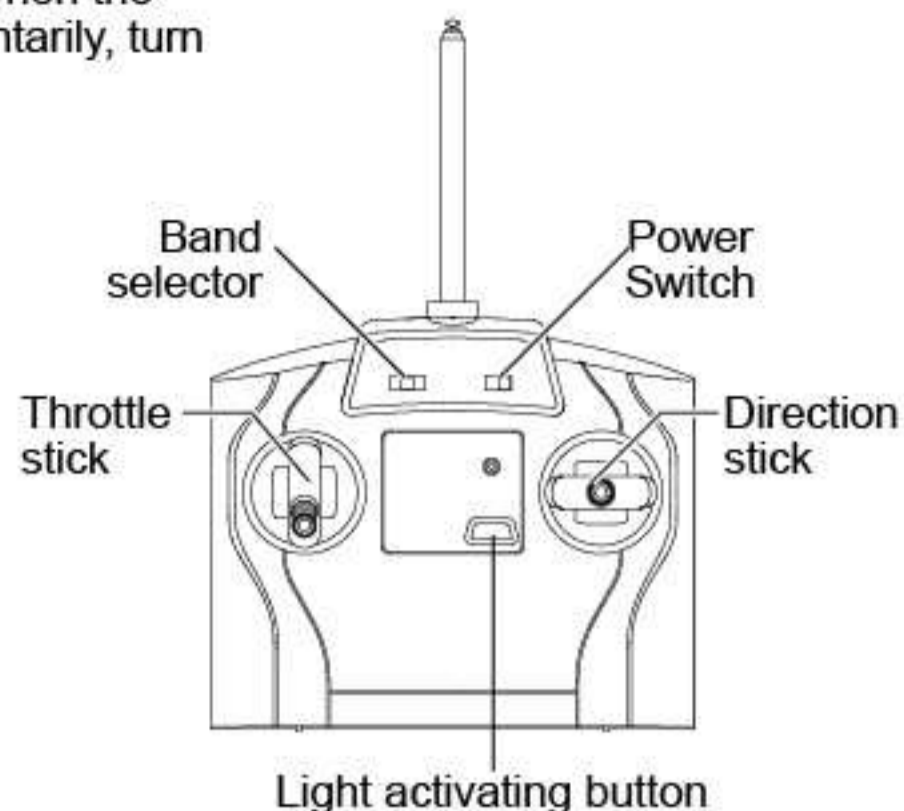

Driving Tips

1. The speed varies at different throttle stick positions.
2. The turning speed and radius may vary at different lever position combinations.
3. Do not touch or hold the antenna of transmitter.
4. Only operate the vehicle on flat, smooth (but not slippery) and dry surfaces or low pile carpets. Hair, carpet or dirt can affect the operation of the vehicle.
5. For best performance, hold the antenna up, do not point it down towards the vehicle.
6. Do not drive the vehicle on sand or through water or snow. If your vehicle gets wet, wipe it with a towel and allow it to dry completely.
7. When the vehicle runs erratically, the problem is usually the result of interference caused by high tension wires, radios or other remote controlled toys running close by on the same frequency as yours. You may have to choose an alternate place to drive.
8. Do not operate near concrete walls which may disturb radio signal transmission.

Troubleshooting

Symptom	Cause	Solution
Vehicle does not react, or react poorly to the transmitter.	- High-frequency interference occurred near to high-voltage lines, transformers and some types of building. - Band selection is not correct. - The transmitter batteries are weak. - The toy is in stand-by mode.	- Avoid these if possible, or choose another place to operate the vehicle. - Select the correct frequency band. - Change new battery in transmitter. - Switch off the toy and turn it on again.
Loss of control.	- Another radio control vehicle using the same frequency and channel is operated near your vehicle. - Out of the transmission range. - Affected by strong lights.	- Race against other vehicles using different frequencies or channel. - Move to another place where without radio frequency interference from other devices. - Ensure the antenna is fully extended. The vehicle has a transmission range of 20 meters (65 feet) in open space. - Change another environment to avoid direct light.
Vehicle runs slowly, erratically or does not run.	- Power switch is not in "ON" position. - Batteries are not installed correctly. - Weak batteries. - Hair, carpet or dirt might be trapped between wheels.	- Switch on the power. - Check the batteries polarity and connection. - Replace them with new ones. - Carefully remove the foreign materials.

Become our fan on facebook
facebook.com/SilverlitToys

Visit us at
www.Silverlit.com

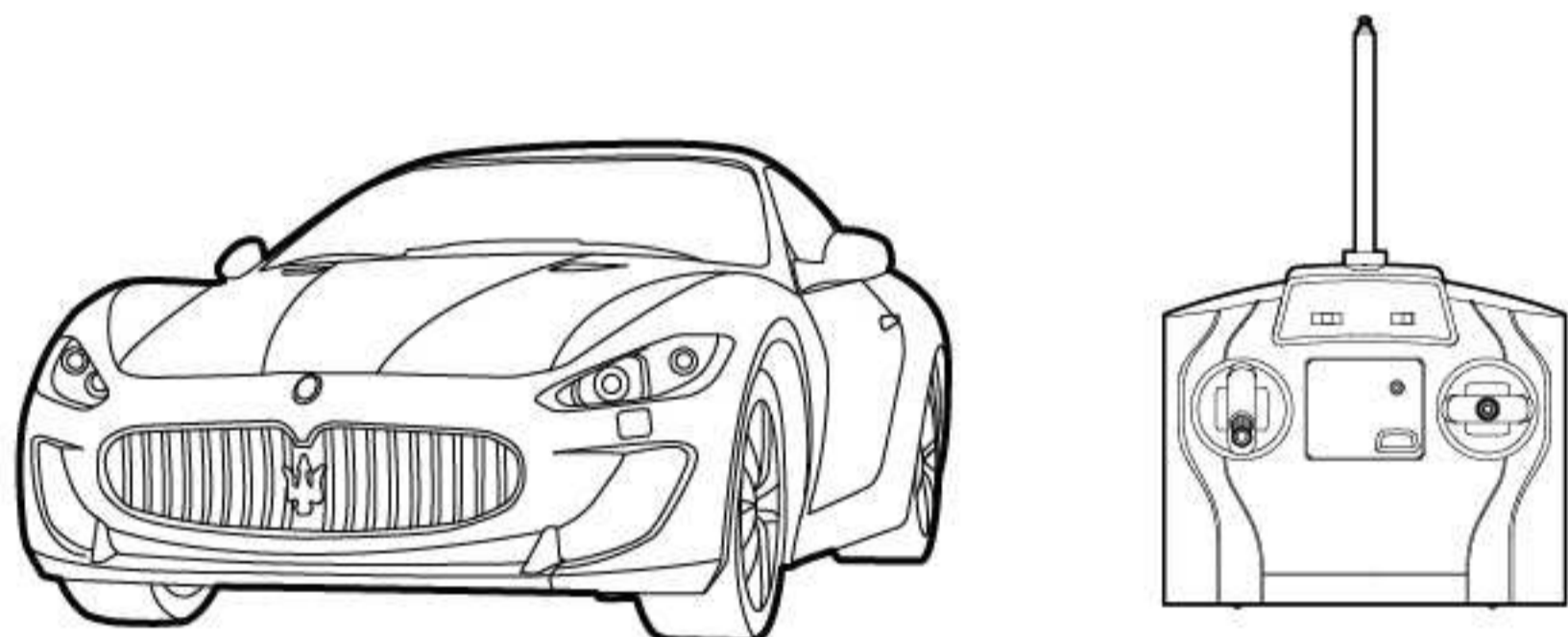

FCC Statements

This device complies with part 15 of the FCC rules. Operation is subject to the following two conditions:
1) This device may not cause harmful interference, and
2) This device must accept any interference received, including interference that may cause undesired operation.
NOTE: This equipment has been tested and found to comply with the limits for a Class B digital device, pursuant to Part 15 of the FCC Rules. These limits are designed to provide reasonable protection against harmful interference in a residential installation. This equipment generates, uses and can radiate radio frequency energy and, if not installed and used in accordance with the instructions, may cause harmful interference to radio communications.
However, there is no guarantee that interference will not occur in a particular installation. If this equipment does cause harmful interference to radio or television reception, which can be determined by turning the equipment off and on, the user is encouraged to try to correct the interference by one or more of the following measures:
- Reorient or relocate the receiving antenna.
- Increase the separation between the equipment and receiver.
- Connect the equipment into an outlet on a circuit different from that to which the receiver is connected.
- Consult the dealer or an experienced radio/TV technician for help.

Part Identification

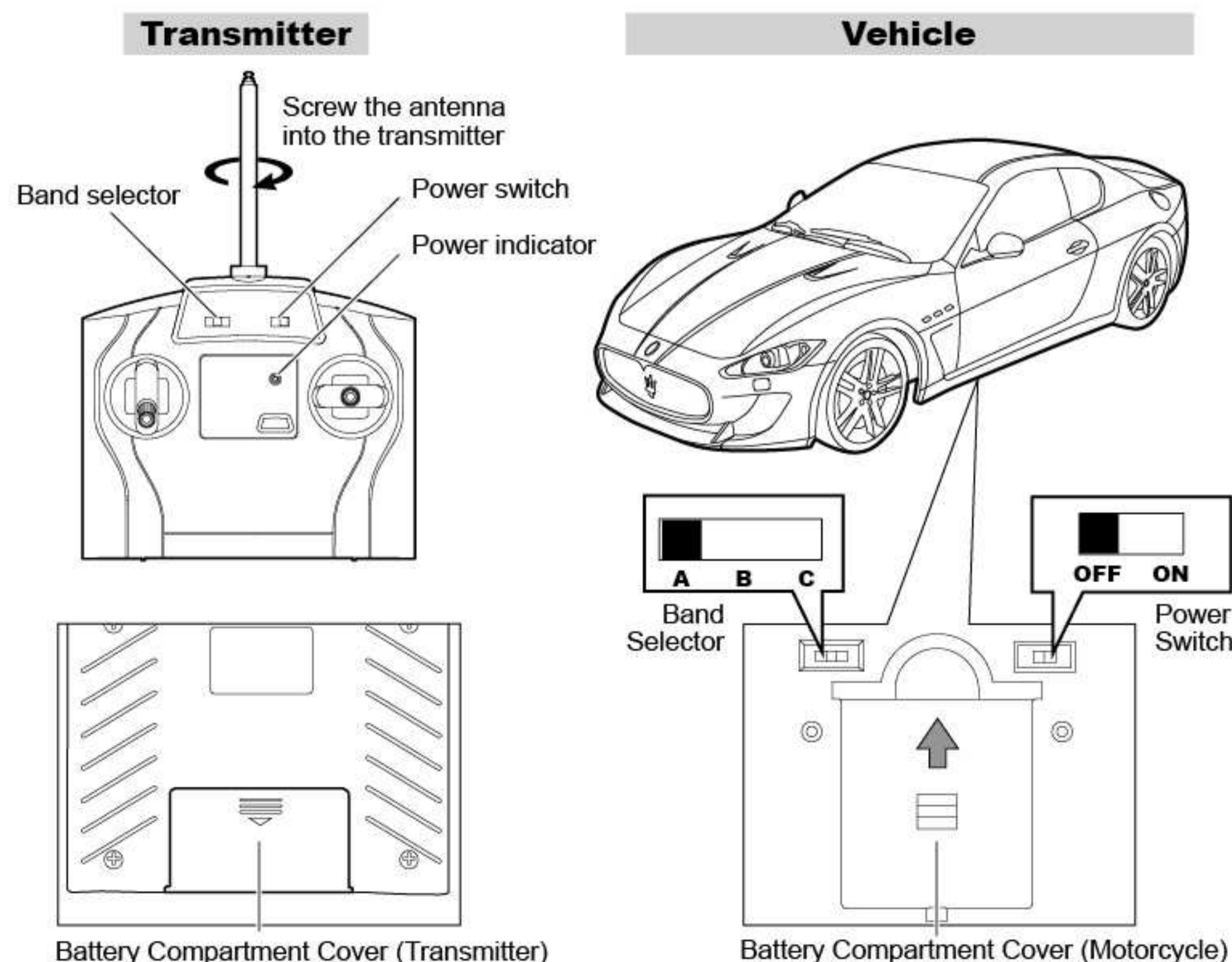

Gran Turismo MC

Delivery contents

- Gran Turismo MC
- Transmitter
- 4 x "AA" size alkaline batteries
- 9 V battery
- Antenna
- Instructions manual



For Ages 5+
Ab 5 Jahre
Pour 5 ans et plus
Voor leeftijd 5+
Para 5+ años
Dai 5 anni in su

This product is in compliance with the essential requirements and other relevant provisions of Directive 1999/5/EC.

Safety precautions

- Parents: Please read the operating instructions carefully with your children prior to the first use.
 - Stop the vehicle through the transmitter before picking it up.
 - Keep hands, hair and loose clothing away from the moving parts, e.g. tires and the wheel hubs, when toy is switched on.
 - Do not operate the remote controlled vehicle on streets. Avoid hitting people, pets or home furnishings.
- Warning:** Conversion or modifications to this product not expressly approved by the party responsible for compliance could void the user's authority to operate the product.

The crossed-out dustbin symbol indicates that batteries, rechargeable batteries, button cells, battery packs, etc. must not be put in the household waste. Batteries are harmful to health and the environment. Please help to protect the environment from health risks. If the toy is out of use, please use common household tool to break the product for built-in rechargeable battery operated toy or unscrew the battery door for replaceable battery operated toy, then take the battery out from the toy. Dispose of battery in accordance with your local battery recycling or disposal laws.



Waste Electrical and Electronic Equipment (WEEE)

When this appliance is out of use, please remove all batteries and dispose of them separately. Bring electrical appliances to the local collecting points for waste electrical and electronic equipment. Other components can be disposed of in domestic refuse.

Battery warnings:

- Non-rechargeable batteries are not to be recharged.
- Rechargeable batteries are to be removed before being recharged.
- Rechargeable batteries are only to be charged under adult supervision.
- Different types of batteries or new and used batteries are not to be mixed.
- Only batteries of the same or equivalent type as recommended are to be used.
- Batteries are to be inserted with correct polarity.
- Exhausted batteries are to be removed from the toy.
- The supply terminals are not to be short-circuited.
- Do not mix old and new batteries.
- Do not mix alkaline, standard (carbon-zinc) or rechargeable (nickel-cadmium) batteries.

WARNING:

**CHOKING HAZARD - Small parts.
Not for Children under 3 years.**

TIPS

For the vehicle, best & maximum performance can be only obtained by new and alkaline batteries.

Care and Maintenance:

- Always remove batteries from the toy when it is not being used for a long period of time.
- Wipe the toy gently with a clean cloth.
- Keep the toy away from direct heat.
- Do not submerge the toy into water that can damage the electronic assemblies.

Notes:

- Parental guidance is recommended when installing or replacing batteries.
- Keep this instruction manual for future reference.
- Users should keep strict accordance with the instruction manual while operation the product.
- Under the environment with electrostatic discharge, the toy may malfunction and require user to reset the toy.
- Use new alkaline batteries in this toy to obtain best performance.

Battery requirements Transmitter:

- Power supply : ---
- Battery ratings : 9 V DC , 0,135 W
- Batteries : 1 x 9 V 6F22 (included)
- Capacity : 450 mAh

Battery requirements Vehicle:

- Power supply : ---
- Battery ratings : 6 V DC , 7,8 W
- Batteries : 4 x 1,5 V "AA"/LR6/AM3 (included)
- Capacity : 2800 mAh

Silverlit® Silverlit SAS, Espace Green Parc, Route de Villepeule, 91280 Saint Pierre du Peryay / France.
©2013 Silverlit. All rights reserved.

MASERATI
OFFICIAL LICENSED PRODUCT
The Maserati logo, the Maserati wordmark and the Maserati model designations are trademarks of Maserati S.p.A. and are used under license.

Getting Started

Batteries:

- The vehicle is powered by 4 x 1.5 V "AA" size batteries.
- The transmitter is powered by 1 x 9V battery.

Battery Installation: Transmitter

Make sure the power switch is on "OFF" position.

1. Pull out the battery compartment cover. (fig. 1)
2. Insert one 9V battery with correct polarity, as shown inside battery compartment (fig. 2).
3. Close the battery compartment cover.

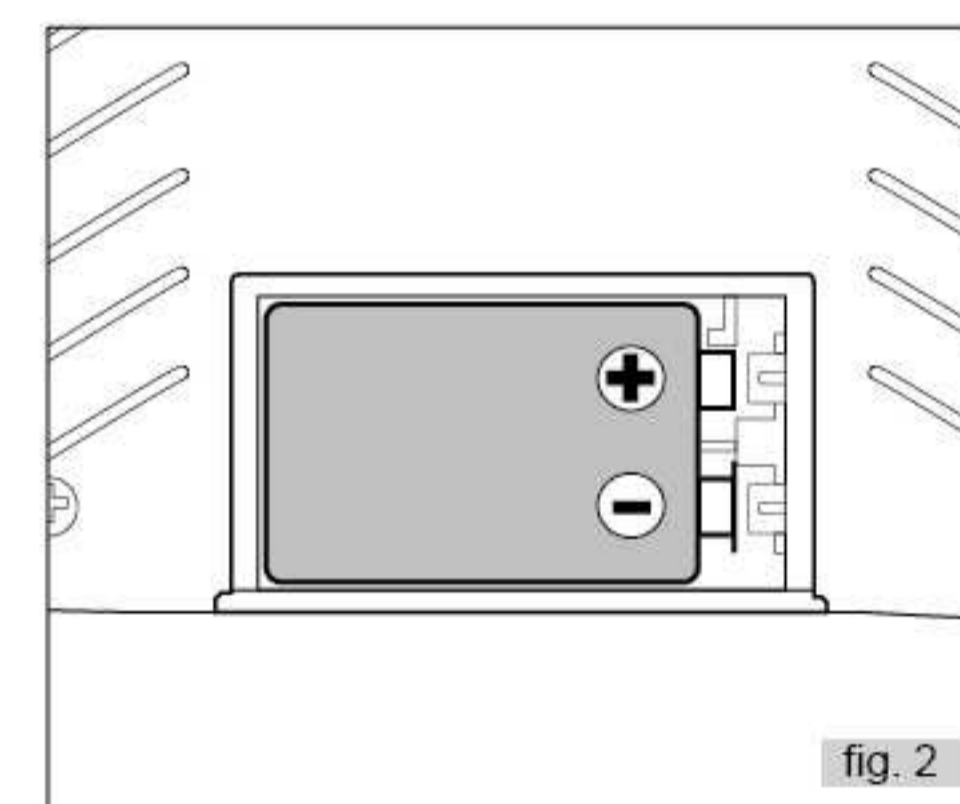
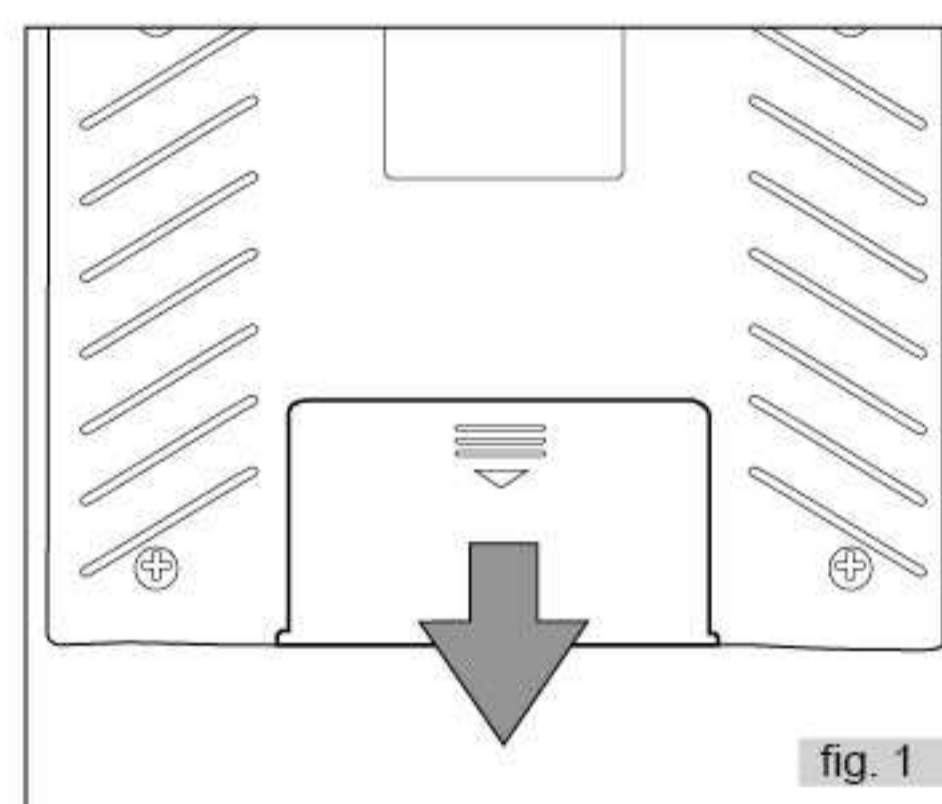

Battery Installation: Vehicle

Make sure the power switch is on "OFF" position.

1. Press down the button (1) on battery compartment cover, and then follow the arrow (2) direction to push out the battery compartment cover (fig. 3).
2. Insert four "AA" batteries with correct polarity, as shown inside battery compartment (fig. 4).
3. Close the battery compartment cover.

