

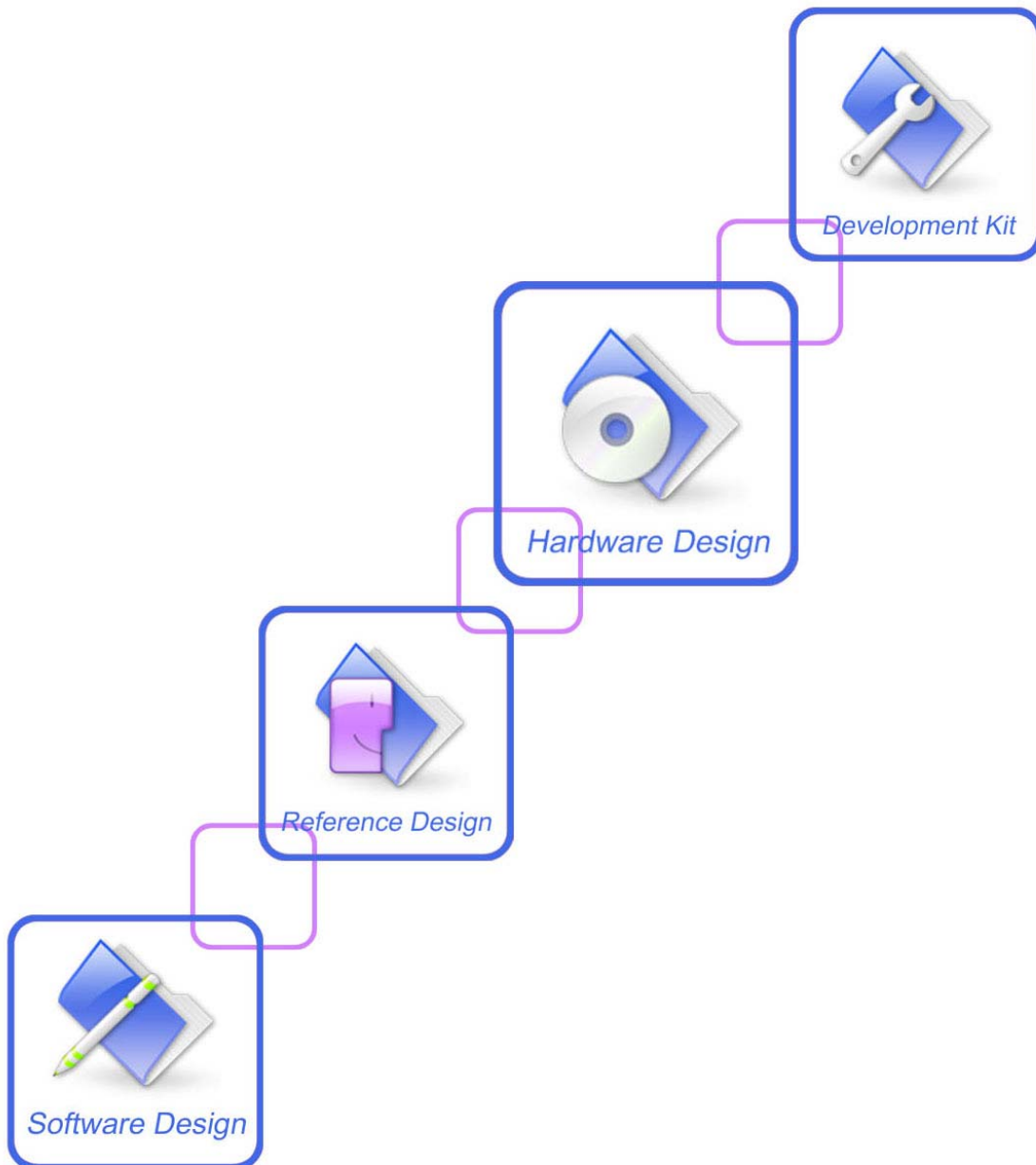

SIM5320A_Hardware Design_V1.01



Document Title	SIM5320A Hardware Design
Version	1.01
Date	2011-2-29
Status	Release
Document Control ID	SIM5320A_Hardware Design_V1.01

General Notes

SIMCom offers this information as a service to its customers, to support application and engineering efforts that use the products designed by SIMCom. The information provided is based upon requirements specifically provided to SIMCom by the customers. SIMCom has not undertaken any independent search for additional relevant information, including any information that may be in the customer's possession. Furthermore, system validation of this product designed by SIMCom within a larger electronic system remains the responsibility of the customer or the customer's system integrator. All specifications supplied herein are subject to change.

NOTICE:

This device complies with Part 15 of the FCC Rules [and with RSS-210 of Industry Canada].

Operation is subject to the following two conditions:

- (1) this device may not cause harmful interference, and*
- (2) this device must accept any interference received, including interference that may cause undesired operation.*

Changes or modifications made to this equipment not expressly approved by SIMCOM may void the FCC authorization to operate this equipment.

This equipment has been tested and found to comply with the limits for a Class B digital device, pursuant to Part 15 of the FCC Rules. These limits are designed to provide reasonable protection against harmful interference in a residential installation. This equipment generates, uses and can radiate radio frequency energy and, if not installed and used in accordance with the instructions, may cause harmful interference to radio communications. However, there is no guarantee that interference will not occur in a particular installation. If this equipment does cause harmful interference to radio or television reception, which can be determined by turning the equipment off and on, the user is encouraged to try to correct the interference by one or more of the following measures:

- Reorient or relocate the receiving antenna.*
- Increase the separation between the equipment and receiver.*
- Connect the equipment into an outlet on a circuit different from that to which the receiver is connected.*
- Consult the dealer or an experienced radio/TV technician for help.*

This Class [B] digital apparatus complies with Canadian ICES-003.

Cet appareil numérique de la classe [B] est conforme à la norme NMB-003 du Canada.

Radiofrequency radiation exposure Information:

The module does not contain antenna. It has an antenna PIN. The module is to be used in mobile or fixed applications only. For other antenna(s) selection, the antenna gain including cable loss must not exceed 7.2 dBi in the 850 MHz Cellular band and 3.5 dBi in the PCS 1900 MHz band, for the purpose of satisfying the requirements of FCC 2.1043 and 2.1091. The antenna used for this module must be installed to provide a separation distance of at least 20 cm from all persons, and must not be co-located or operating in conjunction with other antennas or transmitters within a host device, except in accordance with FCC multi-transmitter product procedures. Compliance of this module in all final product configurations is the responsibility of the Grantee. OEM integrators must be provided with specific information required to satisfy RF exposure compliance for all final host devices and installations. OEM integrators can replace the antenna by themselves. They should comply with Consideration for antenna selection and Consideration for antenna installation.

Copyright

This document contains proprietary technical information which is the property of SIMCom Limited, copying of this document and giving it to others and the using or communication of the contents thereof, are forbidden without express authority. Offenders are liable to the payment of damages. All rights reserved in the event of grant of a patent or the registration of a utility model or design. All specification supplied herein are subject to change without notice at any time.

Copyright © Shanghai SIMCom Wireless Solutions Ltd. 2011

Contents

Revision History	10
1 Introduction	11
1.1 Product Outline	11
1.2 Hardware Interface Overview	11
1.3 Hardware Diagram	12
1.4 Functional Overview	12
2 Package Information	14
2.1 Pin Configuration	14
2.2 Pin description	16
2.3 Package Dimensions	19
2.4 Footprint Recommendation	20
3 Application Interface Specification	21
3.1 Power Supply	21
3.1.1 Power Supply Pin	21
3.1.2 Design Guide	22
3.1.3 RTC Backup	25
3.2 Power on/off Time Sequence	27
3.2.1 Power on Sequence	27
3.2.2 Power off Sequence	28
3.3 UART Interface	30
3.3.1 Pin Description	31
3.3.2 Application Guide	31
3.4 Audio Interfaces	32
3.4.1 Pin Description	33
3.4.2 Design Guide	33
3.4.3 Audio Parameter Characteristic	35
3.5 USIM Interface	36
3.5.1 Pin description	36
3.5.2 Application Guide	36
3.5.3 Recommend Components	37
3.6 I2C Interface	38
3.6.1 Pin Description	39
3.6.2 Signal Description	39
3.6.3 Design Guide	39
3.7 Keypad Interface	39
3.7.1 Pin Description	39
3.7.2 Application Guide	40
3.8 USB Interface	41
3.8.1 Application Guide	41
3.9 SPI Interface	42
3.9.1 Pin Description	42

3.10	GPIO Interface	43
3.10.1	Pin Description	43
3.10.2	Application Guide	44
3.11	PCM Interface	46
3.11.1	Pin Description	46
3.11.2	Signal Description	46
3.12	Global Positioning System	50
3.12.1	Technical specification	50
3.12.2	Operate Mode	50
3.12.3	Application Guide	51
3.13	Multi-functional interface.....	52
3.13.1	Sink Current Source	52
3.13.2	Reset Function.....	53
3.13.3	ADC.....	54
3.13.4	LDO.....	55
4	RF Specification	55
4.1	RF Specification	55
4.2	Operating Specification	56
4.3	Antenna Design Guide.....	57
5	Reliability and Operating Characteristics.....	59
5.1	Electronic Characteristics	59
5.2	Operating Mode.....	59
5.2.1	Operating Modes Overview.....	60
5.2.2	Minimize Power Consumption.....	61
5.3	Current Consumption.....	61
5.4	EMC and ESD Notes.....	64
6	Guide for Production.....	65
6.1	Top and Bottom View of SIM5320A	65
6.2	Typical Solder Reflow Profile	65
6.3	Moisture Sensitivity Level (MSL).....	66
6.4	Stencil Foil Design Recommendation	66
6.5	Recommended Pad Design.....	67
Appendix	68
A.	System Design.....	68
B.	SIM5320A GPIOs List.....	69
C.	Digital I/O Characteristics.....	69
D.	Related Documents	70
E.	Terms and Abbreviations.....	71
F.	Safety Caution.....	74

Table Index

Table 1: SIM5320A series frequency bands.....	11
Table 2: General Feature.....	12
Table 3: Pin definition.....	15
Table 4: Pin description.....	16
Table 5: Pin description.....	21
Table 6: Temperature table.....	24
Table 7: Power on timing.....	28
Table 8: Power off timing.....	29
Table 9: Pin description.....	31
Table 10: Logic level.....	31
Table 11: Pin description.....	33
Table 12: MIC input characteristics.....	33
Table 13: Audio output characteristics.....	33
Table 14: Speaker output characteristics.....	33
Table 15: Audio parameter.....	35
Table 16: Electronic characteristic.....	36
Table 17: Pin description.....	36
Table 18: Pin description.....	39
Table 19: Pin description.....	40
Table 20: GPIO configuration.....	41
Table 21: Electronic characteristic.....	41
Table 22: Electronic characteristic.....	42
Table 23: Pin description.....	43
Table 24: Electronic characteristic.....	43
Table 25: Pin description.....	44
Table 26: LED status.....	45
Table 27: Control status.....	45
Table 28: Electronic characteristic.....	46
Table 29: Pin description.....	46
Table 30: Timing parameters.....	48
Table 31: Timing parameters.....	49
Table 32: Electronic characteristic.....	53
Table 33: Electronic Characteristics.....	54
Table 34: Electronic characteristic.....	55
Table 35: Conducted transmission power.....	55
Table 36: Operating frequencies.....	56
Table 37: Conducted receive sensitivity.....	56
Table 38: GPRS/EDGE data throughout.....	56
Table 39: HSDPA throughout.....	57
Table 40: Absolute maximum ratings.....	59
Table 41: Recommended operating ratings.....	59
Table 42: Operating temperature.....	59

Table 43: Operating Modes Overview	60
Table 44: Current consumption	62
Table 45: The ESD performance measurement table (Temperature: 25°C, Humidity: 45%)	64
Table 46: SIM5320A GPIOs list	69
Table 47: Digital I/O characteristics	69
Table 48: Related documents	70
Table 49: Terms and Abbreviations	71
Table 50: Safety caution	74

SIMCOM CONFIDENTIAL FILE

Figure Index

Figure 1: SIM5320A functional architecture.....	12
Figure 2: Pin view.....	14
Figure 3: Top dimensions (Unit: mm).....	19
Figure 4: Side dimensions (Unit: mm).....	19
Figure 5: Bottom dimensions (Unit: mm).....	20
Figure 6: Footprint recommendation (Unit: mm).....	20
Figure 7: VBAT_RF voltage drop during burst emission (GSM/GPRS).....	21
Figure 8: VBAT input application circuit.....	22
Figure 9: Reference circuit of the LDO power supply.....	23
Figure 10: Reference circuit of the DCDC power supply.....	23
Figure 11: Internal circuit.....	24
Figure 12: Application circuit.....	25
Figure 13: RTC supply from capacitor.....	25
Figure 14: RTC supply from non-chargeable battery.....	26
Figure 15: RTC supply from rechargeable battery.....	26
Figure 16: Seiko XH414H-IV01E Charge-Discharge characteristic.....	26
Figure 17: Power on Timing Sequence.....	27
Figure 18: Application circuit.....	28
Figure 19: Power off timing sequence.....	29
Figure 20: Full modem.....	30
Figure 21: Null modem.....	30
Figure 22: RI behaviour in NULL Modem.....	32
Figure 23: RI behaviour in FULL Modem.....	32
Figure 24: Speaker interface configuration.....	34
Figure 25: Receiver interface configuration.....	34
Figure 26: Microphone interface configuration.....	34
Figure 27: USIM interface reference circuit.....	37
Figure 28: Amphenol SIM card socket.....	38
Figure 29: Reference circuit.....	40
Figure 30: USB interface.....	42
Figure 31: Application circuit.....	44
Figure 32: Flight mode switch.....	45
Figure 33: Synchrony timing.....	47
Figure 34: EXT CODEC to MODULE timing.....	47
Figure 35: MODULE to EXT CODEC timing.....	48
Figure 36: Synchrony timing.....	48
Figure 37: EXT CODEC to MODULE timing.....	49
Figure 38: MODULE to EXT CODEC timing.....	49
Figure 39: Active antenna circuit.....	51
Figure 40: Passive antenna circuit (Default).....	52
Figure 41: Current drive.....	53
Figure 42: Reset circuit.....	54

Figure 43: Reference circuit.....	54
Figure 44: Antenna matching circuit.....	58
Figure 45: Top and bottom view of SIM5320A	65
Figure 46: The ramp-soak-spike reflow profile of SIM5320A.....	66
Figure 47: Recommended pad	67
Figure 48: System design.....	68

SIMCOM CONFIDENTIAL FILE

Revision History

Data	Version	Description of change	Author
2011-2-29	1.01	Original	Xiaoyangyang

SIMCOM CONFIDENTIAL

1 Introduction

This document describes electronic specifications, RF specifications, function interface, mechanical characteristic and testing conclusions of the SIMCom SIM5320A module. With the help of this document and other SIM5320A software application notes, user guides, users can quickly understand and use SIM5320A module to design and develop applications quickly.

1.1 Product Outline

Designed for global market, SIM5320A is a quad-band GSM/GPRS/EDGE and dual-band UMTS /HSDPA that works on frequencies of GSM 850MHz, EGSM 900 MHz, DCS 1800 MHz, PCS 1900MHz and WCDMA 1900/850MHz. User can choose the module based on the wireless network configuration. In this document, the entire radio band configuration of SIM5320A series is described in the following table.

Table 1: SIM5320A series frequency bands

Standard	Frequency	SIM5320A
GSM	GSM 850MHz	✓
	EGSM 900MHz	✓
	DCS1800MHz	✓
	PCS1900MHz	✓
WCDMA	WCDMA 850MHz	✓
	WCDMA 900MHz	
	WCDMA 1900MHz	✓
	WCDMA 2100MHz	
HSPA	HSDPA	✓
	HSUPA	

With a tiny configuration of 30*30*2.9 mm and integrated functions, SIM5320A can meet almost any space requirement in users' application, such as Smart phone, PDA phone, industrial handhelds, machine-to-machine, vehicle applications, etc..

There are 80 pins on SIM5320A, which provide most application interfaces for customers' board.

1.2 Hardware Interface Overview

Sub-interfaces are described in detail in the next chapter, which includes:

- Power Supply
- USB Interface
- Serial Interface
- Analog Audio Interfaces
- SIM Interface
- GPIO
- ADC
- LDO Power Output
- Sink Current Source
- PCM Interface
- Keypad Interface
- SPI Interface
- RTC
- I2C Interface

1.3 Hardware Diagram

The global architecture of the SIM5320A Embedded module is described in the figure below.

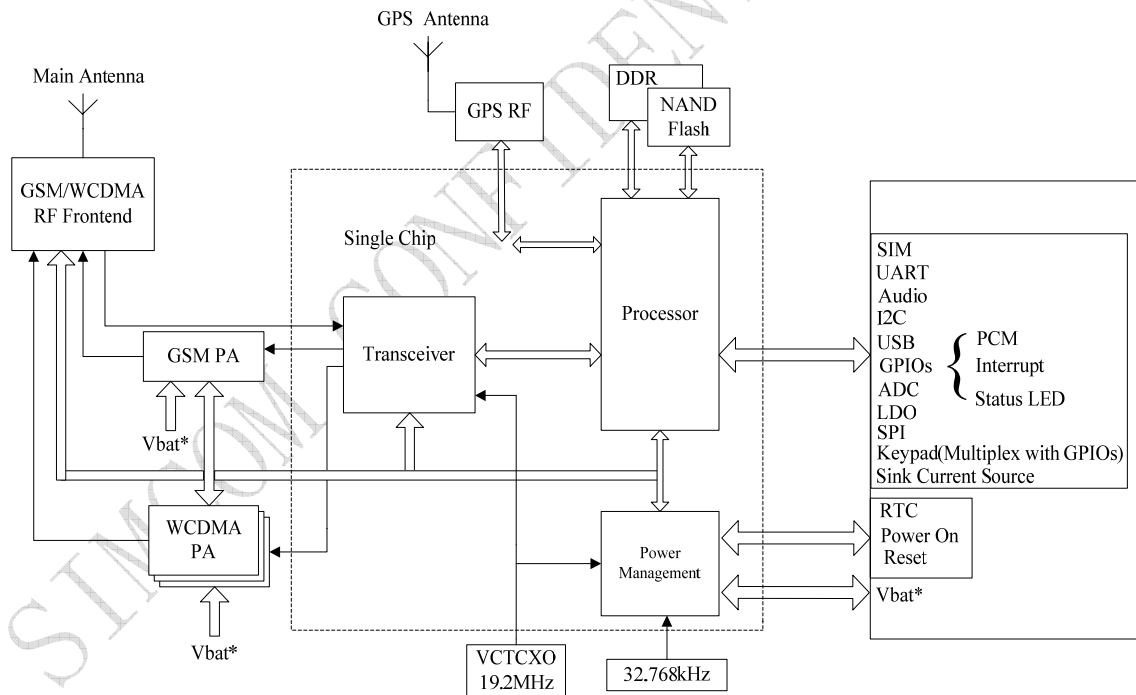

Figure 1: SIM5320A functional architecture

1.4 Functional Overview

Table 2: General Feature

Feature	Implementation
---------	----------------

Power supply	Single supply voltage 3.3~4.2V
Transmission data	<ul style="list-style-type: none"> ● Dual-mode UMTS/HSDPA/EDGE/GPRS operation ● GPRS Class B, multislots class 12 operation, Supports coding scheme: CS1-4 ● EDGE multislots class 12 operation, Supports coding schemes MSC1-9 ● UMTS R99 data rates-384 kbps DL/UL ● HSDPA Category 5/6 -3.6 Mbps Category12-1.8 Mbps ● CSD feature: 9.6, 14.4, 64 kbps UL/DL
GPS	<ul style="list-style-type: none"> ● Mobile-Assisted mode ● Mobile-based mode ● Standalone mode
SMS	<ul style="list-style-type: none"> ● MT, MO, CB, Text and PDU mode ● SMS storage: SIM card ● Support transmission of SMS alternatively over CSD or GPRS. User can choose preferred mode.
SIM interface	Support identity card: 1.8V, 3V.
Audio features(optional)	<p>Speech codec modes:</p> <ul style="list-style-type: none"> ● Half Rate (ETS 06.20) ● Full Rate (ETS 06.10) ● Enhanced Full Rate (ETS 06.50 / 06.60 / 06.80) ● AMR (WCDMA) ● AMR+QCP (GSM) ● A5/1, A5/2, and A5/3 ciphering
Serial interface	<ul style="list-style-type: none"> ● Serial Port standard or null modem mode on Serial Port Interface ● Serial Port can be used to control module by sending AT command
USB	Support USB2.0 Slave mode
Phonebook management	Support phonebook types: SM, FD, LD, RC, ON, MC.
SIM application toolkit	Support SAT class 3, GSM 11.14 Release 98 Support USAT
Real Time Clock	Support RTC
Timer function	Programmable by AT command
Physical characteristics	Size:30*30*2.9mm Weight:5.6g
Firmware upgrade	Firmware upgrade over USB interface
PCM	Multiplex on GPIOs. 3 kinds of coding formats: 8 bit (u-law or A-law) and 16 bit (linear).
Temperature range	<ul style="list-style-type: none"> ● Operation temperature: -30°C to +80°C ● Storage temperature -40°C to +85°C

2 Package Information

2.1 Pin Configuration

All hardware interfaces which connect SIM5320A to customers' application platform are through 80 pins pads (Metal half hole). Figure 2 is SIM5320A outline diagram.

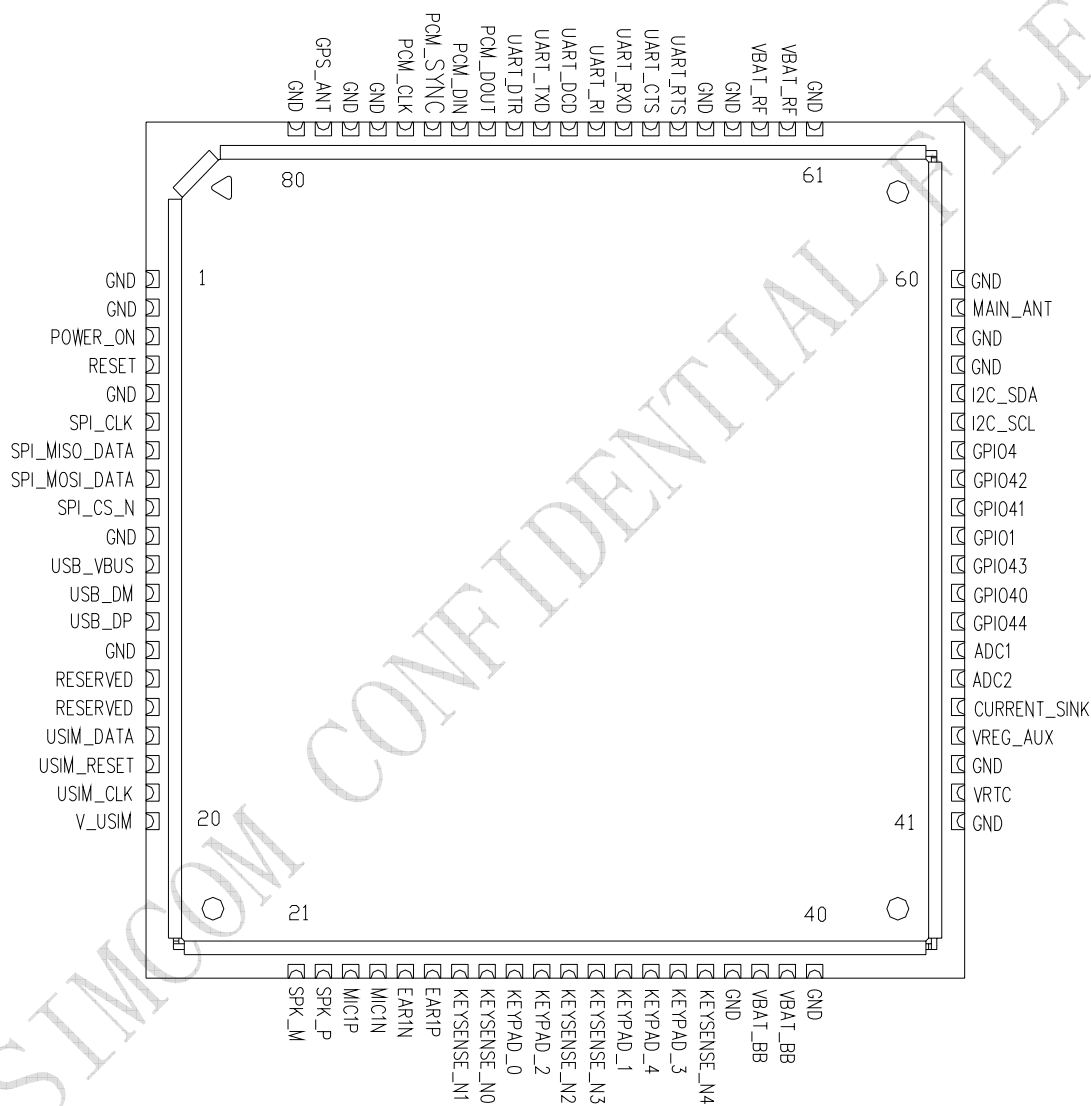

Figure 2: Pin view

Table 3: Pin definition

Pin No.	Define	Pin No.	Define
1	GND	2	GND
3	POWER_ON	4	RESET
5	GND	6	SPI_CLK
7	SPI_MISO_DATA	8	SPI_MOSI_DATA
9	SPI_CS_N	10	GND
11	USB_VBUS	12	USB_DM
13	USB_DP	14	GND
15	RESERVED	16	RESERVED
17	USIM_DATA	18	USIM_RESET
19	USIM_CLK	20	V_USIM
21	SPK_M	22	SPK_P
23	MIC1P	24	MIC1N
25	EAR1N	26	EAR1P
27	KEYSENSE_N1	28	KEYSENSE_N0
29	KEYPAD_0	30	KEYPAD_2
31	KEYSENSE_N2	32	KEYSENSE_N3
33	KEYPAD_1	34	KEYPAD_4
35	KEYPAD_3	36	KEYSENSE_N4
37	GND	38	VBAT_BB
39	VBAT_BB	40	GND
41	GND	42	VRTC
43	GND	44	VREG_AUX
45	CURRENT_SINK	46	ADC2
47	ADC1	48	GPIO44
49	GPIO40	50	GPIO43
51	GPIO1	52	GPIO41
53	GPIO42	54	GPIO4
55	I2C_SCL	56	I2C_SDA
57	GND	58	GND
59	MAIN_ANT	60	GND
61	GND	62	VBAT_RF
63	VBAT_RF	64	GND
65	GND	66	UART_RTS

67	UART_CTS	68	UART_RXD
69	UART_RI	70	UART_DCD
71	UART_TXD	72	UART_DTR
73	PCM_DOUT	74	PCM_DIN
75	PCM_SYNC	76	PCM_CLK
77	GND	78	GND
79	GPS_ANT	80	GND

2.2 Pin description

Table 4: Pin description

Pin name	I/O	Description	Comment
Power Supply			
VBAT_RF/VBAT_BB		Power supply voltage	
VRTC	I/O	Power supply for RTC	If it is unused, keep open.
VREG_AUX	O	LDO power output	
GND		Ground	
Power on/off			
POWER_ON	I	POWER_ON should be pulled low at least 64ms to power on or 500ms to power off the module.	
Audio interface			
MIC1P	I	Differential audio input	If it is unused, connect to ground through a 100N capacitor.
MIC1N			
EAR1P	O	Differential audio output	If these pins are unused, keep open.
EAR1N			
SPK_P	O		
SPK_N			
USIM interface			
V_USIM	O	Voltage Supply for SIM card Support 1.8V or 3V SIM card	All signals of SIM interface should be protected against ESD/EMC.
USIM_DATA	I/O	SIM Data Output/Input	
USIM_CLK	O	SIM Clock	
USIM_RESET	O	SIM Reset	
SPI interface			
SPI_CLK	O	SPI clock	If it is unused, keep open.
SPI_CS_N	O	SPI chip-select	

SPI_MOSI_DATA	O	SPI (master only) master out/slave in data	
SPI_MISO_DATA	I	SPI (master only) master in/slave out data	
USB			
USB_VBUS	I	USB power supply input	
USB_DP	I/O	Plus (+) line of the differential, bi-directional USB signal to/from the peripheral device.	They are compliant with the USB 2.0 specification. If it is unused, keep open.
USB_DM	I/O	Minus (-) line of the differential, bi-directional USB signal to/from the peripheral device.	
Serial interface			
UART_RXD	I	Receive Data	UART_RXD has been pulled down with a 12kR resistor to ground in the module. If it is unused, keep open.
UART_TXD	O	Transmit Data	
UART_RTS	O	Request to send	
UART_CTS	I	Clear to Send	
UART_RI	O	Ring Indicator	
UART_DTR	I/O	DTE get ready	
UART_DCD	O	Carrier detects	
I2C interface			
I2C_SDA	I/O	I2C data	Pulled up with a 2.2kR resistor to 2.6V internally. If it is unused, keep open.
I2C_SCL	O	I2C clock output	
Keypad interface			
KEYPAD_0	O	Bit 0 drive to the pad matrix	All Keypad pins can be configured as GPIOs. If it is unused, keep open.
KEYPAD_1	O	Bit 1 drive to the pad matrix	
KEYPAD_2	O	Bit 2 drive to the pad matrix	
KEYPAD_3	O	Bit 3 drive to the pad matrix	
KEYPAD_4	O	Bit 4 drive to the pad matrix	
KEYSENSE_N0	I	Bit 0 for sensing key press on pad matrix	
KEYSENSE_N1	I	Bit 1 for sensing key press on pad matrix	
KEYSENSE_N2	I	Bit 2 for sensing key press on pad matrix	
KEYSENSE_N3	I	Bit 3 for sensing key press on pad matrix	
KEYSENSE_N4	I	Bit 4 for sensing key press on pad matrix	
PCM interface			
PCM_DIN/GPIO0	I	General Input PIN with module wake/interrupt. It also can be multiplexed as the PCM_DIN pin.	If it is unused, keep open.

PCM_SYNC/GPIO2	I	General Input PIN. It also can be multiplexed as the PCM_SYNC pin.	
PCM_CLK/GPIO3	O	General Output PIN. It also can be multiplexed as the PCM_CLK pin.	
PCM_DOUT/GPIO5	O	General Output PIN. It also can be multiplexed as the PCM_DOUT pin.	
GPIOs			
GPIO1	O	Output PIN as LED control for network status.	If it is unused, keep open.
GPIO4	I	Input PIN as RF operating control.	
GPIO40	O	Output PIN as operating status indicating of module.	
GPIO41	I/O	General input/output PIN. It can be used as wake/interrupt signal to host from module	
GPIO43	I/O	General input/output PIN. It can be used as wake/interrupt signal to module from host.	
GPIO44	I/O	General input/output PIN.	
GPIO42	I/O	General input/output PIN.	
Other interface			
RESET	I	System reset in, active low.	
CURRENT_SINK	I	Current source of ground-referenced current sink	Refer to 3.13
ADC1	I	Analog Digital Converter Input	Refer to 3.13
ADC2	I	Battery temperature ADC input pin	Detailed description please refers to chapter 3.1.2.
MAIN_ANT	I/O	ANT soldering pad	
GPS_ANT	I/O	GPS ANT soldering pad	

SIMCOM

2.3 Package Dimensions

The following figure shows mechanical dimensions of SIM5320A.

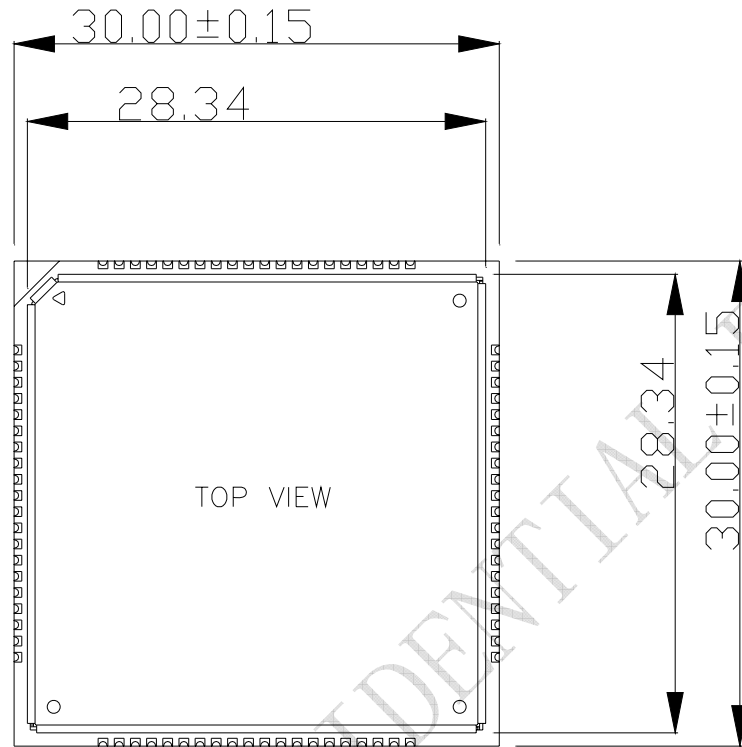

Figure 3: Top dimensions (Unit: mm)

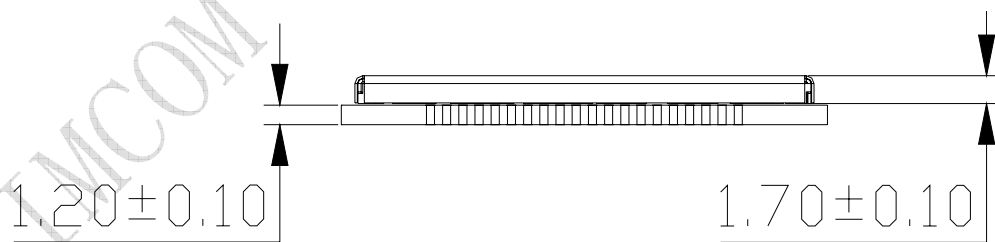

Figure 4: Side dimensions (Unit: mm)

3 Application Interface Specification

3.1 Power Supply

The power supply pins of SIM5320A include VBAT_RF and VBAT_BB. VBAT_RF directly supplies the power to RF PA; VBAT_BB supplies the power to the baseband system. For the VBAT_RF, the ripple due to GSM/GPRS emission burst (every 4.615ms) may cause voltage drop, and the current consumption rises typically to peak of 2A. So the power supply must be able to provide sufficient current up to 2A. The following figure is the VBAT_RF voltage ripple wave at the maximum power transmit phase.

The test condition: VBAT_RF=4.0V, VBAT maximum output current =2A, $C_A=100\ \mu\text{F}$ tantalum capacitor (ESR=0.7 Ω) and $C_B=1\ \mu\text{F}$ (Please refer to Figure 8—Application circuit).

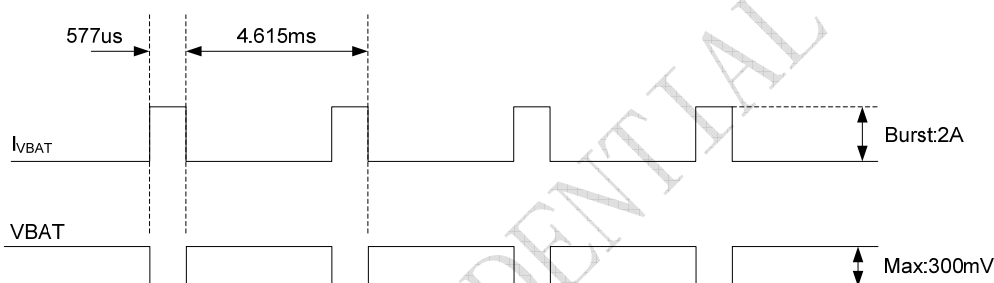

Figure 7: VBAT_RF voltage drop during burst emission (GSM/GPRS)

3.1.1 Power Supply Pin

Two VBAT_RF and two VBAT_BB pins are dedicated to connect the supply voltage.

Table 5: Pin description

Pin type	Pin name	Min	Typ	Max	Unit
POWER	VBAT_RF	3.3	3.8	4.2	V
	VBAT_BB	3.3	3.8	4.2	V

Note: 1. Though the VBAT_RF and VBAT_BB are supplied by the same voltage level, they are different pins. VBAT_RF is for RF section and VBAT_BB is for baseband system.

2. When the module is power off, users must pay attention to the issue about current leakage. Refer to Chapter 3.10.2

Note2.

3.1.2 Design Guide

Mostly, user connects the VBAT_RF and VBAT_BB pins with one power supply. Make sure that the input voltage at the VBAT_BB pin will never drop below 3.3V even during a transmit burst when the current consumption rises up to 2A. If the power voltage drops below 3.3V, the module may be shut down automatically. Using a large tantalum capacitor (above 100uF) will be the best way to reduce the voltage drops. If the power current cannot support up to 2A, users must introduce larger capacitor (typical 1000uF) to storage electric power, especially GPRS multiple time slots emission.

For the consideration of RF performance and system stability, another large capacitor (above 100uF) should be located at the VBAT_RF pin and some multi-layer ceramic chip (MLCC) capacitors (0.1uF) need to be used for EMC because of their low ESR in high frequencies. Note that capacitors should be put beside VBAT_RF pins as close as possible. Also User should minimize the PCB trace impedance from the power supply to the VBAT pins through widening the trace to 80 mil or more on the board. The following figure is the recommended circuit.

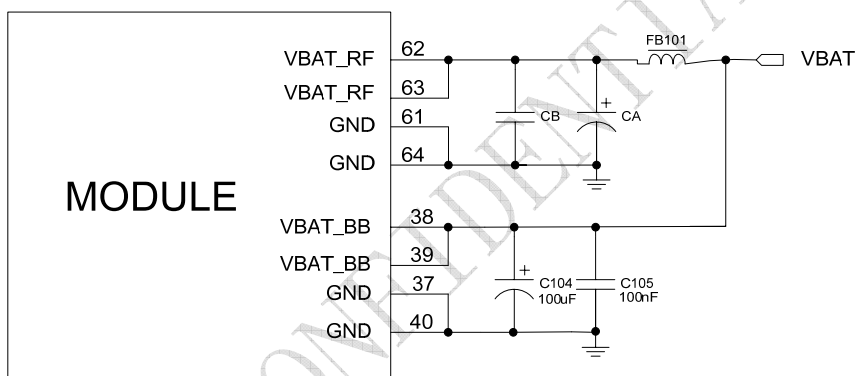

Figure 8: VBAT input application circuit

There are three sections about how to design and optimize users' power systems.

Power supply circuit

We recommend DCDC or LDO is used for the power supply of the module, make sure that the peak current of power components can rise up to 2A. The following figure is the reference design of +5V input power supply. The designed output for the power supply is 4.1V, here a linear regulator can be used.

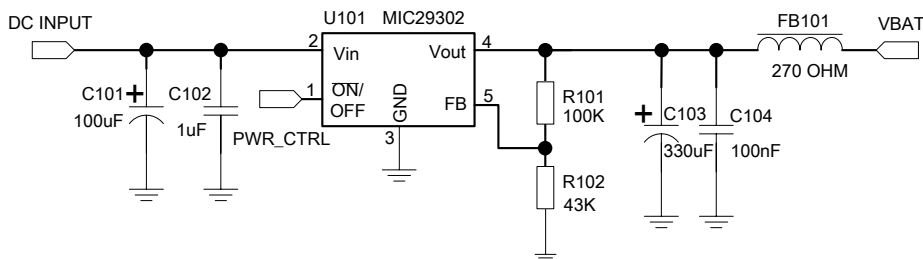

Figure 9: Reference circuit of the LDO power supply

If there is a big difference between the input voltage and the desired output (VBAT), a switching converter power will be preferable because of its better efficiency, especially at the high current situation. The following figure is the reference circuit. Note that DCDC may deprave RF performance because of ripple current intrinsically.

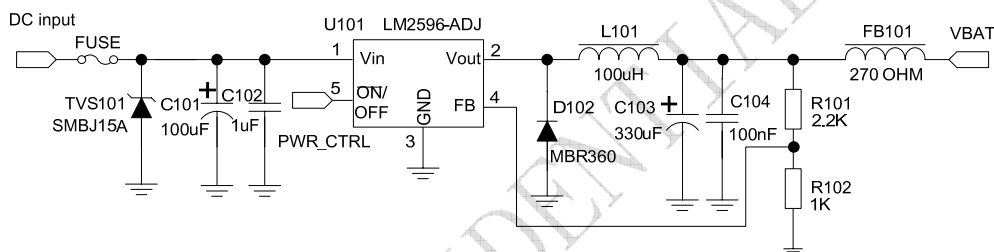

Figure 10: Reference circuit of the DCDC power supply

Voltage monitor

To monitor the power supply voltage, user can use the AT command “AT+CBC”, this command has two parameters: the battery status and the voltage value (mV). It will return the capacity percentage and actual value of battery (at the VBAT_BB pin). The voltage is continuously measured at intervals, whenever the measured battery voltage is lower than a specific value set by the AT command “AT+CVALARM”. For example, if the voltage value is set to be 3.4V, the following URC will be presented: “warning! voltage is low: 3.3v”.

If the voltage is lower than a specific value which is set by the AT command “AT+CPMVT”, the module will be powered off automatically and AT commands cannot be executed any more.

Note: Under-voltage warning function is disabled by default, user can enable it by the AT command “AT+CVALARM”. Auto power off feature is disabled by default, user should set it by the AT command “AT+CPMVT” to an appropriate value. Please refer to Document [1].

Temperature monitor

ADC interface can be used to monitor the temperature of power components to avoid over temperature. An external NTC resistor (such as NCP15XH103F03RC) can be used to measure the device temperature. The ADC1 pin can be used as external voltage detection. Please refer to Chapter 3.17. ADC2 is the ADC input pin for temperature detection. The following figure shows the application circuit.

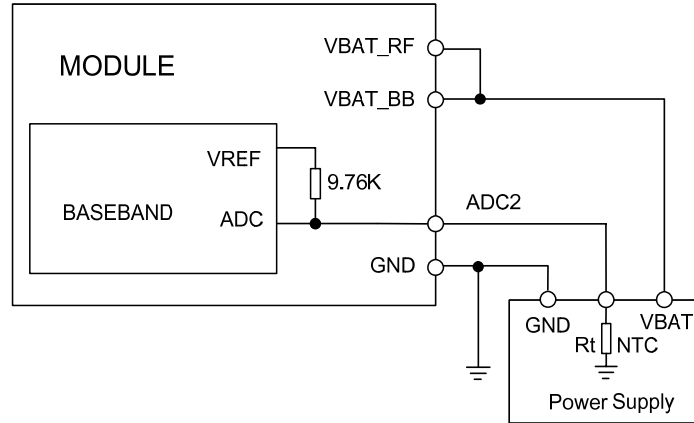

Figure 11: Internal circuit

From above figure, the input voltage can be calculated:

$$V_{adc} = 2.2 * R_t / (R_t + 9.76) \text{ (V)}$$

R_t is a NTC thermistor.

The default temperature VS V_{adc} voltage table is shown below.

Table 6: Temperature table

Temperature degree(°C)	V_{adc} (mV)
-30	1887
-20	1814
-10	1711
0	1574
10	1408
20	1224
30	1035
40	856
50	695
60	558
70	446
80	355

Make sure that the NTC thermistor can meet the above requirement. User can also add some resistors to get desired voltage. The value of R1, R2 can be calculated according to the NTC curve and the above table. Please refer to the following circuit for user's application.

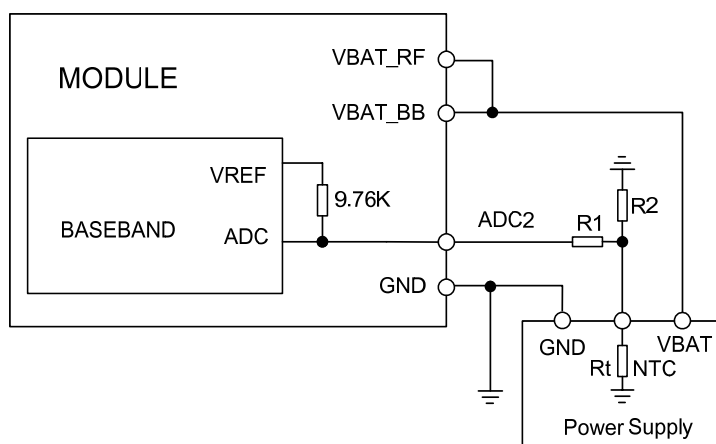

Figure 12: Application circuit

Normally $R1=750\Omega$. Then the input voltage can be calculated by the following formula:

$$V_{adc} = 2.2 * R_f / (R_f + 9.76 + 0.75) \text{ (V)} \quad \text{---} \quad R_f = R_t * R_2 / (R_t + R_2)$$

User can take out R2 value through the existing V_{adc} and the value of NTC thermistor in a specific temperature.

3.1.3 RTC Backup

The module uses RTC (Real Time Clock) to update and maintain inherent time and keeps system alive at no power supply status. The RTC power supply of module can be provided by an external capacitor or a battery (non-chargeable or rechargeable) through the VRTC. The following figures show various reference circuits for RTC back up. The discharge current is less than 10uA. If this feature is used, please refer to the AT commands "AT+CTZU" and "AT+CTZR".

- **External capacitor backup**

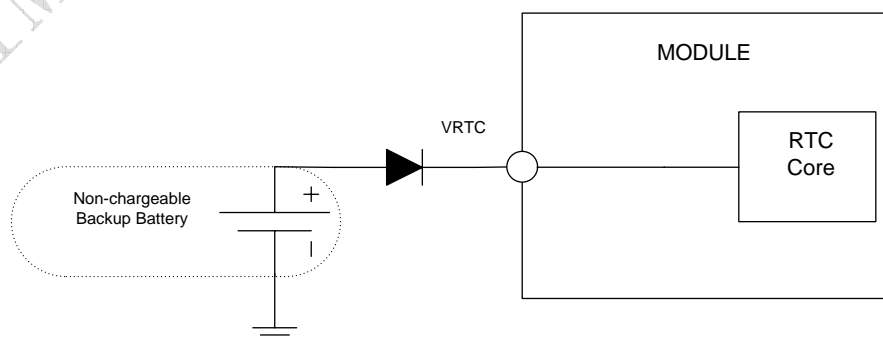

Figure 13: RTC supply from capacitor

- Non-chargeable battery backup

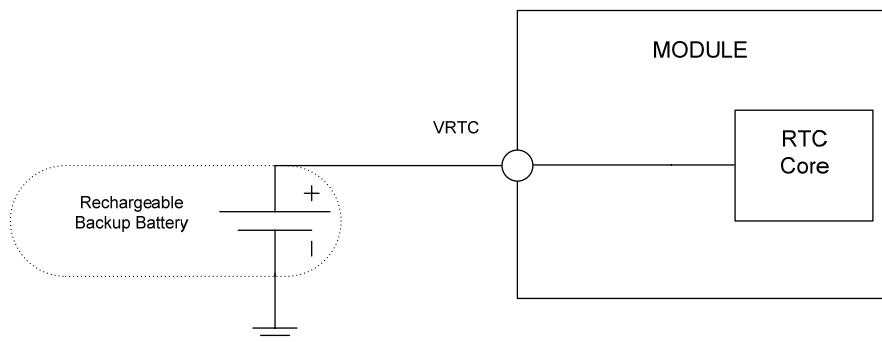

Figure 14: RTC supply from non-chargeable battery

- Rechargeable battery backup

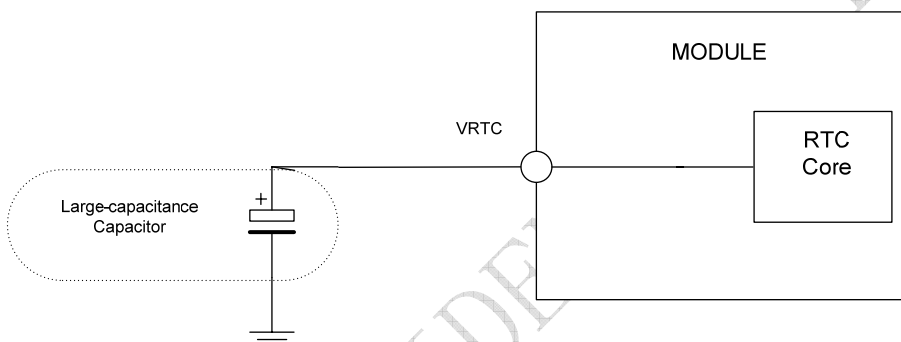

Figure 15: RTC supply from rechargeable battery

Note: The VRTC can be disabled, just disconnect it in application circuit.

Coin-type rechargeable battery is recommended, such as XH414H-IV01E form Seiko can be used. Typical charge-discharge curves for this battery are shown in the following figure.

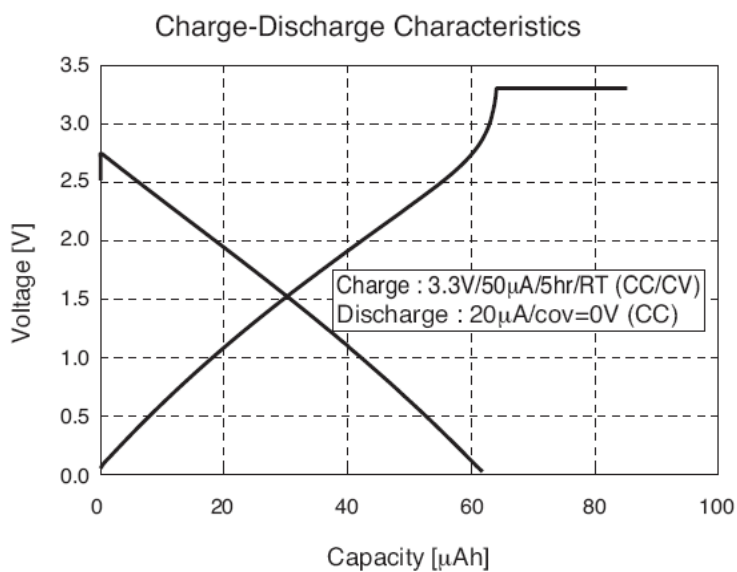

Figure 16: Seiko XH414H-IV01E Charge-Discharge characteristic

3.2 Power on/off Time Sequence

3.2.1 Power on Sequence

SIM5320A can be powered on by POWER_ON pin, which starts normal operating mode. POWER_ON pin is pulled up with a 200kR resistor to 1.8V in module. User can power on the SIM5320A by pulling the POWER_ON pin down for a short time. The power-on scenarios are illustrated in the following figures.

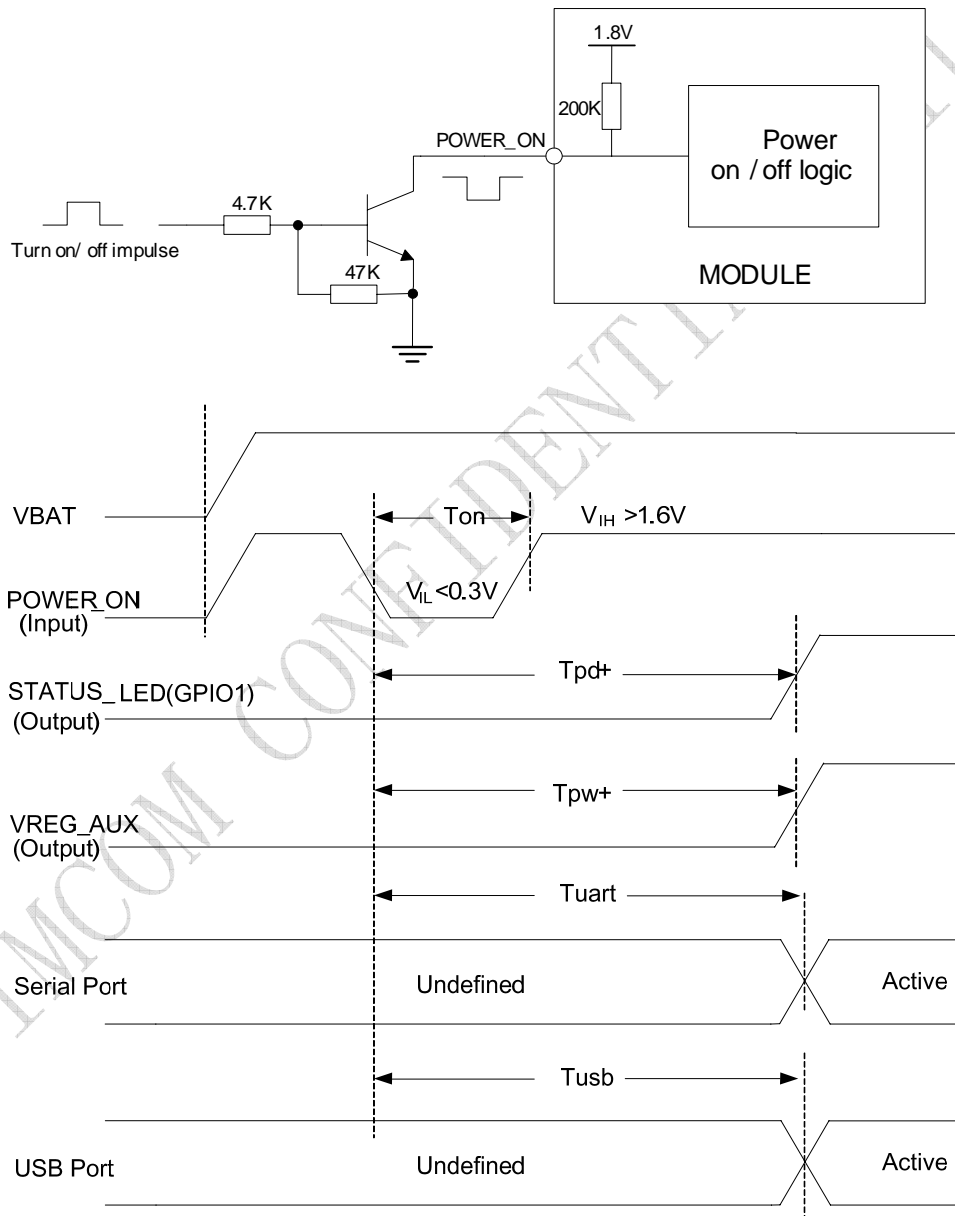

Figure 17: Power on Timing Sequence

Table 7: Power on timing

Parameter	Description	Time value	Unit
Ton	The time to pull POWER_ON down to power on	64 < Ton < 180	ms
TpD+	The time to indicate connecting with the network	>5.5	s
Tpw+	The time to indicate the module is powered on completely	>4.5	s
Tuart	The time to enable UART	>4.7	s
Tusb	The time to enable USB	>9	s

Automatic power on

If user needs to power on SIM5320A automatically whenever the VBAT pins are connected to the power supply, then POWER_ON pin is just pulled to ground by a resistance in circuit directly. The following is the reference circuit.

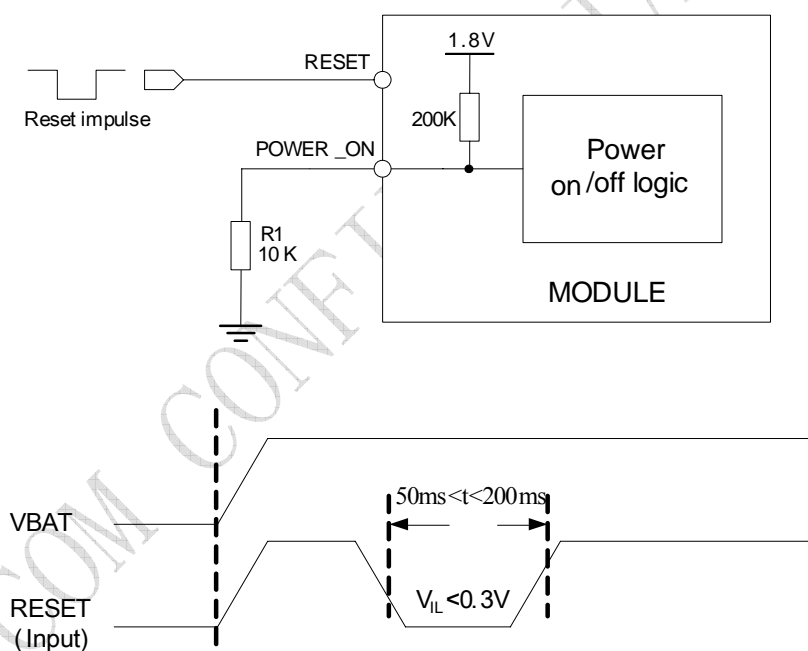

Figure 18: Application circuit

Note: After automatically powering on the module by pulling down POWER_ON pin to ground anytime, USB/UART may not communicate normally with host, so it is suggested that SIM5320A should be reset by RESET pin.

3.2.2 Power off Sequence

The following methods can be used to power down SIM5320A. These procedures will make module disconnect from the network and allow the software to enter a safe state, and then save data before completely powering the module off.

- Method 1: Power off SIM5320A by pulling the POWER_ON pin down
- Method 2: Power off SIM5320A by AT command

User can power off the SIM5320A by pulling POWER_ON down for a specific time. The power off scenario is illustrated in the following figure.

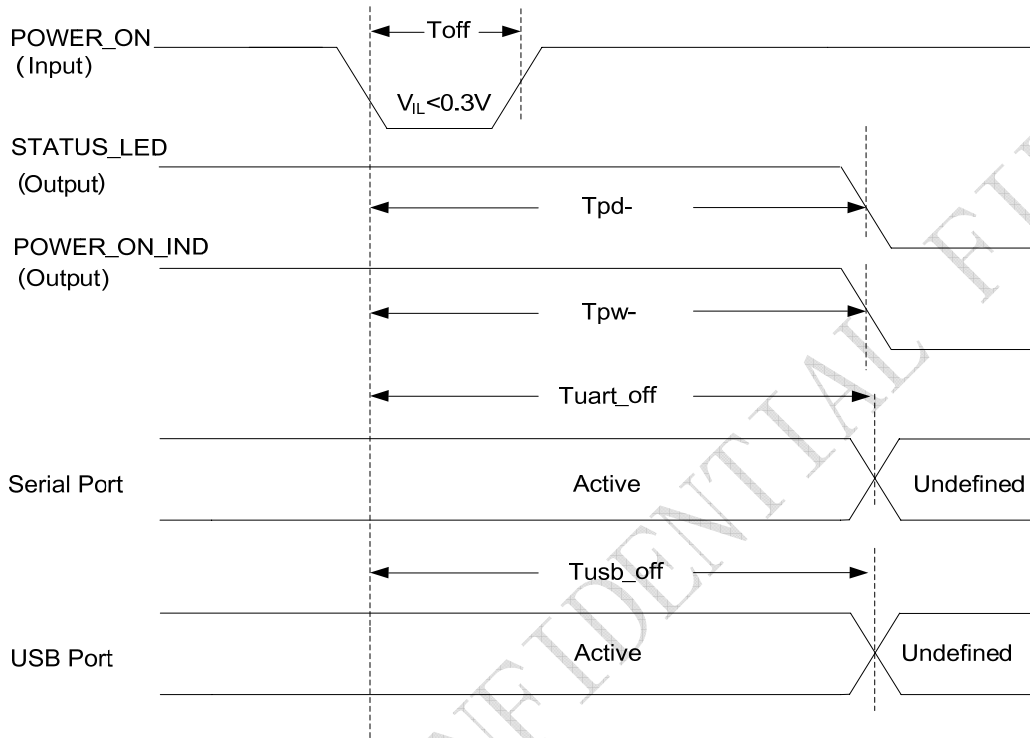

Figure 19: Power off timing sequence

Table 8: Power off timing

Parameter	Description	Time value	Unit
T_{off}	The time pulling POWER_ON down to power off	$0.5 < T_{off} < 5$	s
T_{pd-}	The time to indicate disconnecting from the network	> 7	s
T_{pw-}	The time to indicate the module power off completely	> 7.5	s
T_{uart_off}	The time to disable UART	> 6	s
T_{usb_off}	The time to disable USB	> 7.5	s

User can also use the AT command “AT+CPOF” to power down the module. After that, the AT commands cannot be executed any longer. The module enters the POWER DOWN mode, only the RTC is still active. For details, refer to *Document [1]*.

3.3 UART Interface

SIM5320A provides a UART (universal asynchronous serial transmission) port. It consists of a flexible 7-wire serial interface. The module is as the DCE (Data Communication Equipment) and the client PC is as the DTE (Data Terminal Equipment). AT commands are entered and serial communication is performed through UART interface. The application circuit is in the following figures.

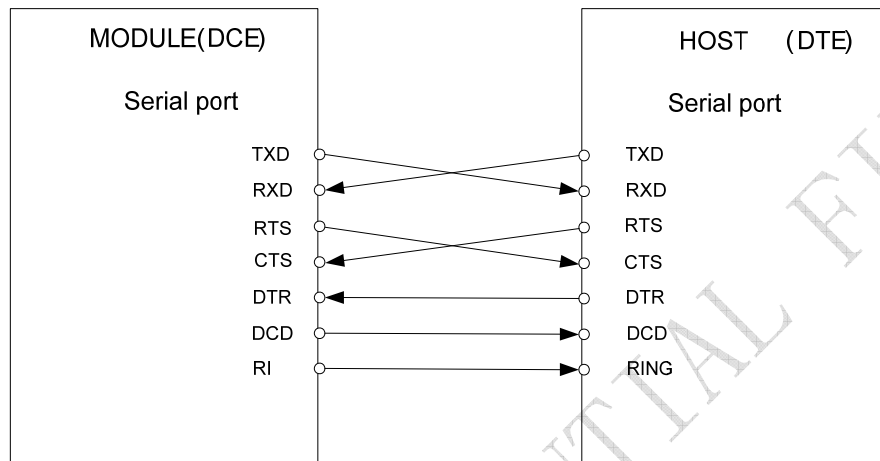

Figure 20: Full modem

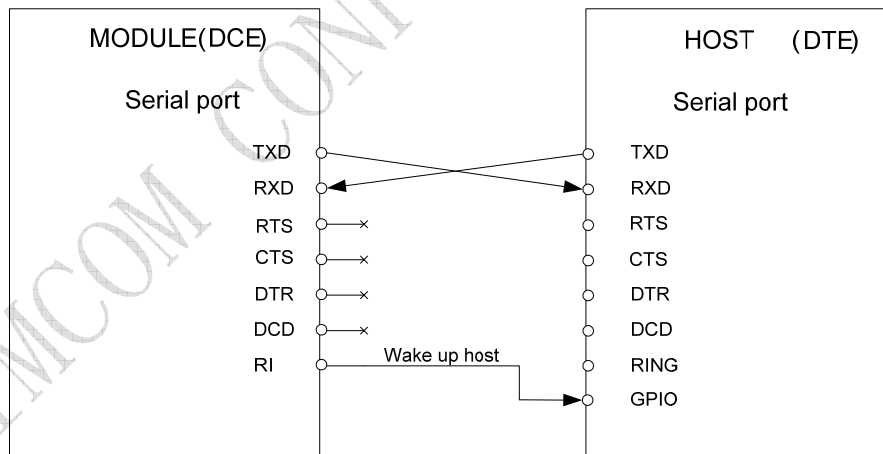

Figure 21: Null modem

3.3.1 Pin Description

Table 9: Pin description

Pin type	Pin name	Pin No.	I/O	Active voltage	Default Status
UART	UART_RXD	68	I	H	Pull-Down
	UART_TXD	71	O	H	Pull-Up
	UART_RTS	66	O	H	
	UART_CTS	67	I	H	Pull-Up
	UART_DTR	72	I	H	Pull-Up
	UART_DCD	70	O	H	
	UART_RI	69	O	H	

More pin information refers to chapter 2.2.

Table 10: Logic level

Parameter	Min	Max	Unit
Logic low input	0	0.3*VDD_EXT	V
Logic high input	0.7 *VDD_EXT	VDD_EXT +0.3	V
Logic low output	GND	0.2	V
Logic high output	VDD_EXT -0.2	VDD_EXT	V

Note: VDD_EXT (=2.6V) is e reference voltage in module internal interface.

All pins of all serial ports have 8mA driver capacity.

3.3.2 Application Guide

If UART port is used in Null Modem, the pin “RI” can be used as an interrupt signal to HOST. Normally it will keep high logic level until certain condition such as receiving SMS, voice call (CSD, video) or URC reporting, then “RI” will change to low logic level to inform the master (client PC). It will stay low until the master clears the interrupt event with AT command.

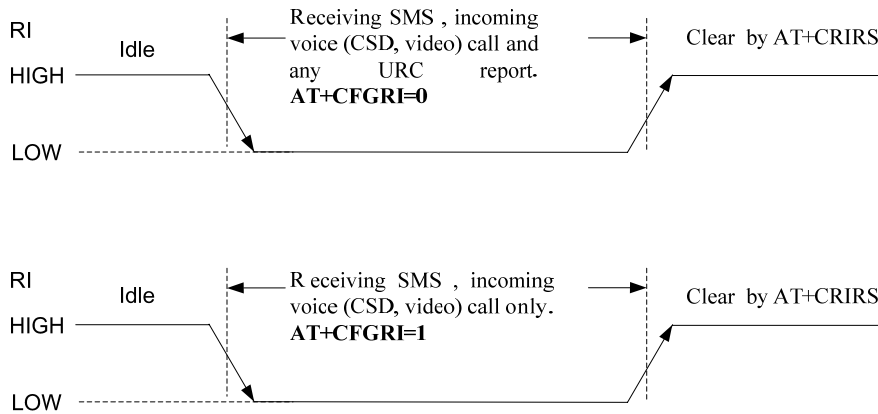

Figure 22: RI behaviour in NULL Modem

If Full Modem is used to establish communication between devices, the pin “RI” is another operation status. Initially it keeps high, when a voice call or CSD call comes, the pin “RI” will change to low for about 5900ms, then it will return to high level for 100ms. It will repeat this procedure until this call is answered or hung up.

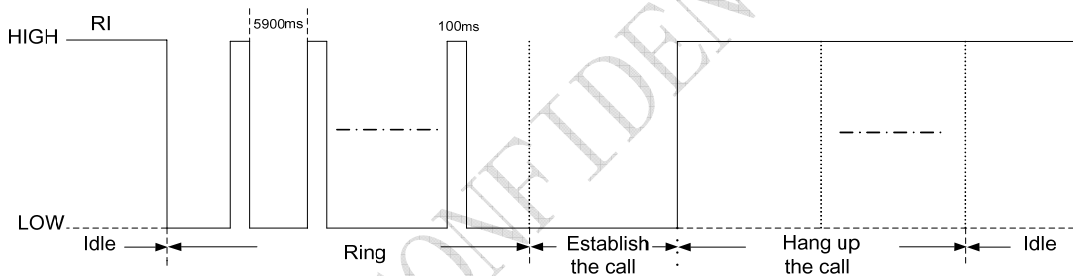

Figure 23: RI behaviour in FULL Modem

To comply with RS-232 protocol, the RS-232 level shifter chip should be used to connect SIM5320A to the RS-232-C interface. In this connection, the TTL level and RS-232 level are converted mutually. SIMCom recommends that user uses the SP3238ECA chip with a full modem. For more information please refers to the RS-232 chip datasheet.

Note: SIM5320A supports the communication rate: 300, 600, 1200, 2400, 4800, 9600, 19200, 38400, 57600, 115200, 230400, 460800, 921600, 3200000, 3686400, 4000000bps. Default rate is 115200bps.

3.4 Audio Interfaces

SIM5320A provides two analog signal outputs and one analog input. MIC1P/N is used as microphone, EAR1P/N and SPK_P/N are used as audio output. Regarding audio parameters configuration, please refer to the ATC manual.

3.4.1 Pin Description

Table 11: Pin description

Audio channel	Pin name	Pin No.	Function
Normal	MIC1P	23	MIC positive input
	MIC1N	24	MIC negative input
	EAR1P	26	Receiver positive output
	EAR1N	25	Receiver negative output
Hand-free	MIC1P	23	MIC positive input
	MIC1N	24	MIC negative input
	SPK_P	22	Loudspeaker positive output
	SPK_N	21	Loudspeaker negative output

Table 12: MIC input characteristics

Parameter	Min	Typ	Max	Unit
Working Voltage	-	1.8	-	V
Working Current	0.07	0.4	1	mA
External Microphone Load Resistance	1.2	2.2		k Ohms

Table 13: Audio output characteristics

Parameter	Min	Typ	Max	Unit		
Normal (EAR_P,EAR_N)	Differential	Load resistance	27	32	-	Ohm
		Output power	-	50	-	mW

Table 14: Speaker output characteristics

Parameter	Min	Typ	Max	Unit
Quiescent Current	-	2.5	4	mA
Output power(1KHz)	-	500	-	mW

3.4.2 Design Guide

There are three audio channels in SIM5320A, including speaker output, receiver output and microphone input.

SPEAKER circuit in SIM5320A is a Class-D amplifier, optional EMI filter is shown in the following figure; these components (two ferrite beads and two capacitors) can reduce electromagnetic interference. If used, they should be located beside SPK_P and SPK_N pins. Considerable current flows in the channels, so wider PCB traces are recommended (~ 20 mils).

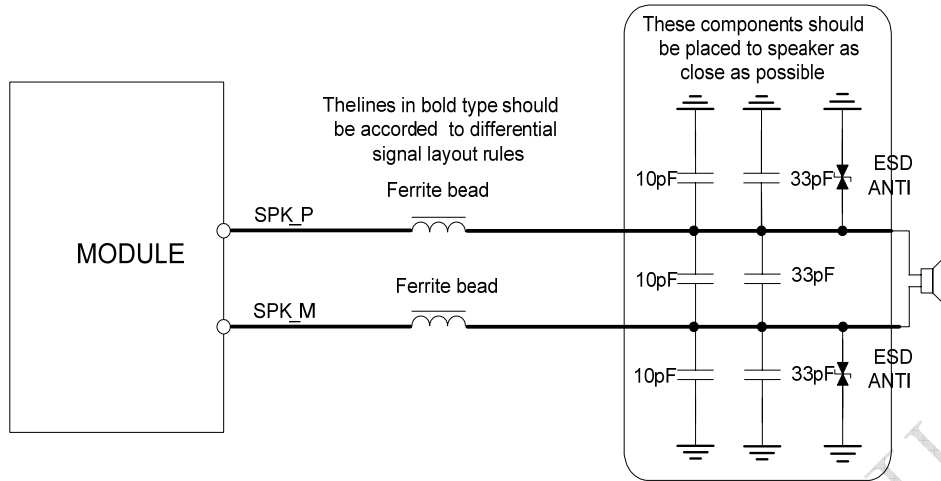

Figure 24: Speaker interface configuration

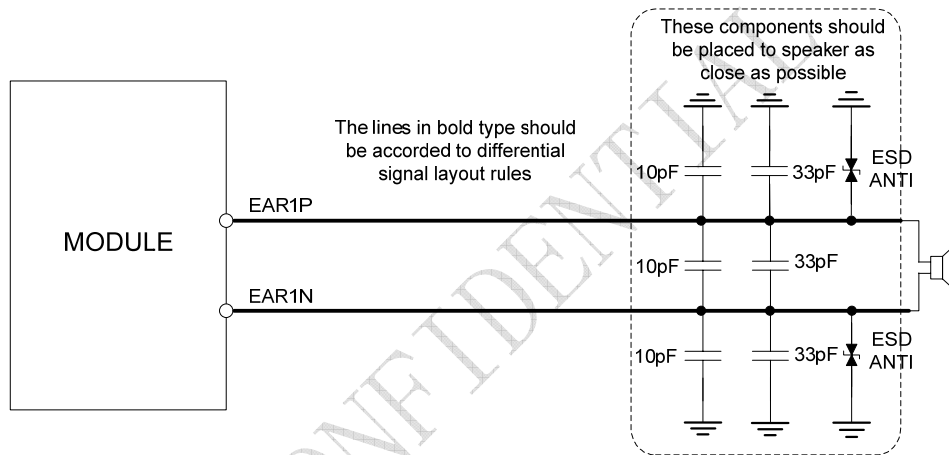

Figure 25: Receiver interface configuration

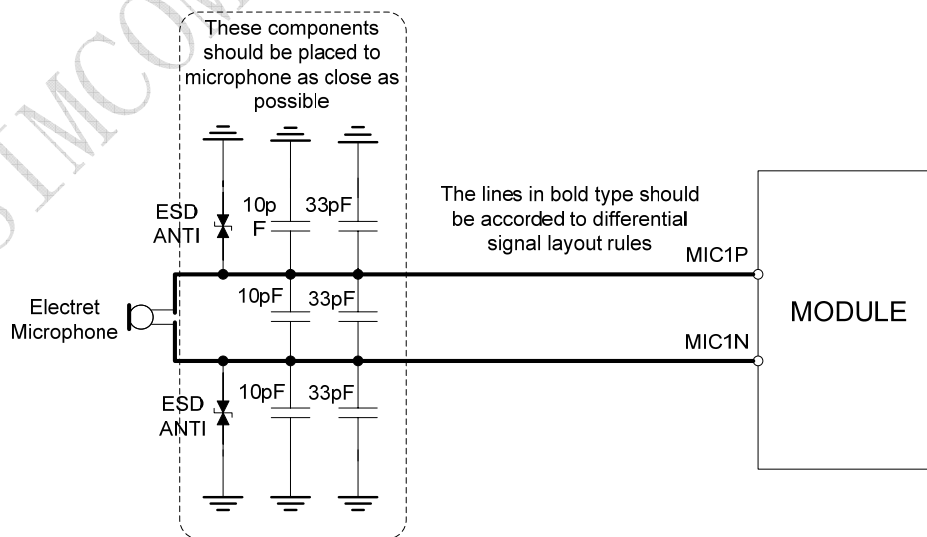

Figure 26: Microphone interface configuration

Note: SIM5320A has integrated MIC bias circuit. There is no need to pull the MICIP and MICIN up to the external power, just connect it to microphone. MICIP and MICIN must be differential lines.

3.4.3 Audio Parameter Characteristic

Main audio parameters can be changed to satisfy users' requirement. Here primary register parameters and related description are listed. User can adjust them through AT command. For more detail please refers to Audio Application Document.

Table 15: Audio parameter

Parameter	Influence to	Range	Gain range	Calculation	AT command
micAmp1	MICP/MICN analogue amplifier gain before ADC	0...1	0...24dB	2 steps	AT+CMICAMP1
txVol	Digital gain of input signal after ADC	0, 1...65535	Mute, -84...+12dB	$20 * \log(\text{txVol}/16384)$	AT+CTXVOL
txGain	Digital gain of input signal after summation of sidetone	0, 1...65535	Mute, -84...+12dB	$20 * \log(\text{txGain}/16384)$	AT+CTXGAIN
txFilter	Input PCM 13-tap filter parameters, 7 values	0...65535	---	MATLAB calculate	AT+CTXFTR
rxGain	Digital gain of output signal after summation of sidetone	0, 1...65535	Mute, -84...+12dB	$20 * \log(\text{rxGain}/16384)$	AT+CRXGAIN
rxVol	Digital Volume of output signal after speech decoder, before summation of sidetone and DAC	-300...300	dbm	-300...300dbm	AT+CLVL AT+CVLVL AT+CRXVOL
stGain	Digital attenuation of sidetone	0, 1...65535	Mute, -96...0dB	$20 * \log(\text{stGain}/16384) - 12$	AT+SIDET
rxFilter	Output PCM 13-tap filter parameters, 7 values	0...65535	---	MATLAB calculate	AT+CRXFTR

Note: If users require better experience on audio, users should modify these parameters according to their own electronic

and mechanical design.

3.5 USIM Interface

The USIM provides the required subscription verification information to allow the mobile equipment to attach to a GSM or UMTS network. Both 1.8V and 3.0V SIM Cards are supported.

3.5.1 Pin description

Table 16: Electronic characteristic

Pin name	3.0V mode			1.8V mode		
	Min	Typ	Max	Min	Typ	Max
V_USIM	2.7	3.00	3.3	1.65	1.8	2.0
USIM_RESET	0.8* V_USIM	3.00	V_USIM	0.8* V_USIM	1.8	V_USIM
USIM_CLK	0.7* V_USIM	3.00	V_USIM	0.8* V_USIM	1.8	V_USIM
USIM_DATA	0.7* V_USIM	3.00	V_USIM	0.8* V_USIM	1.8	V_USIM

Table 17: Pin description

Pin name	Pin	Description
USIM_CLK	19	USIM Card Clock
USIM_RESET	18	USIM Card Reset
USIM_DATA	17	USIM Card data I/O, which has been pulled up with a 22kR resistor to V_USIM in module. Do not pull up or pull down in users' application circuit.
V_USIM	20	USIM Card Power output depends automatically on USIM mode, one is 3.0V±10%, another is 1.8V±10%. Current is less than 50mA.

3.5.2 Application Guide

It is recommended to use an ESD protection component such as ST (www.st.com) ESDA6V1W5 or ON SEMI (www.onsemi.com) SMF05C. Note that the SIM peripheral circuit should be close to the SIM card socket. The reference circuit of the 8-pin SIM card holder is illustrated in the following figure.

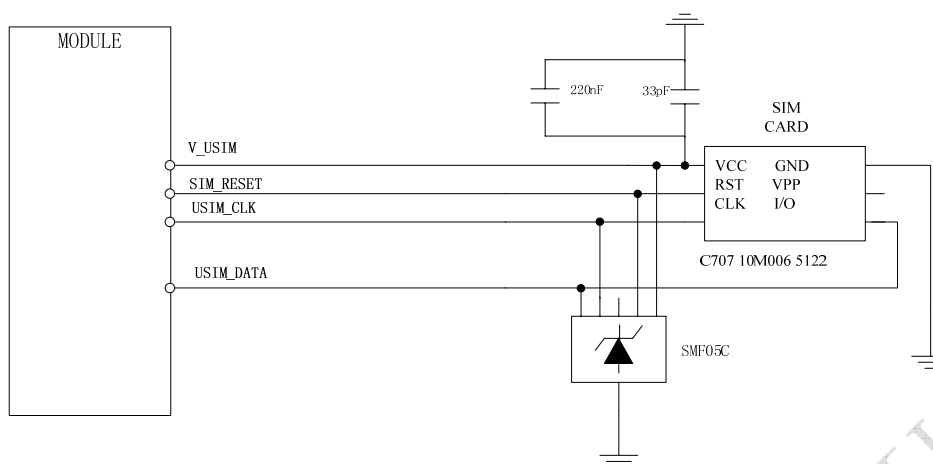

Figure 27: USIM interface reference circuit

Note: USIM_DATA has been pulled up with a 22kR resistor to V_USIM in module. A 220nF shut capacitor on V_USIM is used to reduce interference. Use AT Commands to get information in USIM card. For more detail, please refer to document [1].

3.5.3 Recommend Components

For 6 pins USIM socket, SIMCom recommend to use Amphenol **C707 10M006 512 2**. User can visit <http://www.amphenol.com> for more information about the holder.

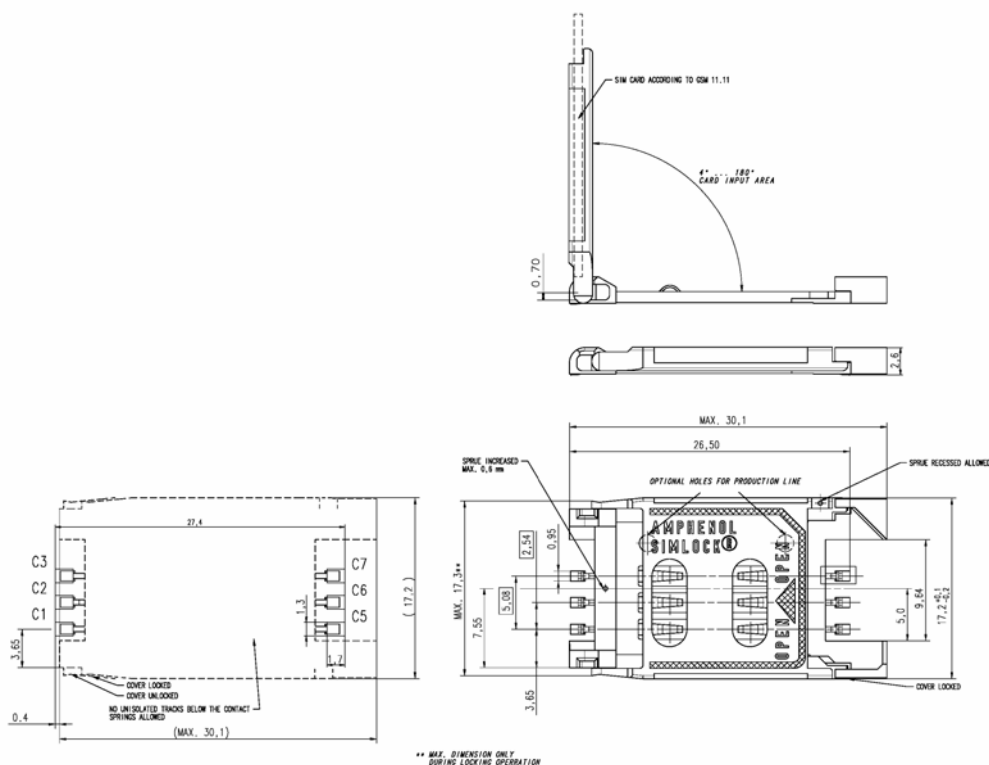

Figure 28: Amphenol SIM card socket

Table 19: Amphenol USIM socket pin description

Pin	Signal	Description
C1	USIM_VDD	SIM Card Power supply, it can identify automatically the SIM Card power mode, one is 3.0V±10%, another is 1.8V±10%.
C2	USIM_RST	SIM Card Reset.
C3	USIM_CLK	SIM Card Clock.
C5	GND	Connect to GND.
C6	VPP	Connect to USIM_VDD
C7	USIM_DATA	SIM Card data I/O.

3.6 I2C Interface

I2C is used to communicate with peripheral equipments and can be operated as either a transmitter or receiver, depending on the device function. Use AT Commands “AT+CRIC and AT+CWIC” to read/write register values of related peripheral equipments connected with I2C interface.

3.6.1 Pin Description

Table 18: Pin description

Pin name	Pin No.	Function
I2C_SDA	56	Serial interface data input and output
I2C_SCL	55	Serial interface clock input

3.6.2 Signal Description

Both SDA and SCL are bidirectional lines, connected to a positive supply via a pull-up resistor respectively. When the bus is free, both lines are high.

3.6.3 Design Guide

For SIM5320A, the data on the I2C bus can be transferred at rates up to 400kbps. The number of peripheral devices connected to the bus is solely dependent on the bus capacitance limit of 400pF. Note that PCB traces length and bending are in users' control to minimize load capacitance.

Note: I2C_SDA and I2C_SCL have been pulled up with two 2.2kR resistors to 2.6V level in module. So there is no need to pull them up in users' application circuit.

3.7 Keypad Interface

SIM5320A module provides a keypad interface that supports five sense lines, or columns, and five keypad rows. The interface generates an interrupt when any key is pressed. Its operation voltage is 1.8V.

3.7.1 Pin Description

Table 19: Pin description

Pin name	Pin No.	Function
KEYSENSE_N0	28	Sensing keys
KEYSENSE_N1	27	
KEYSENSE_N2	31	
KEYSENSE_N3	32	
KEYSENSE_N4	36	
KEYPAD_0	30	Driving pads
KEYPAD_1	29	
KEYPAD_2	30	
KEYPAD_3	35	
KEYPAD_4	34	

3.7.2 Application Guide

All keypad pins can be configured for GPIOs. These GPIOs also support interruption operation if used as input pins. A typical circuit about the keypad (5*5 keypad matrix) is shown in the following figure.

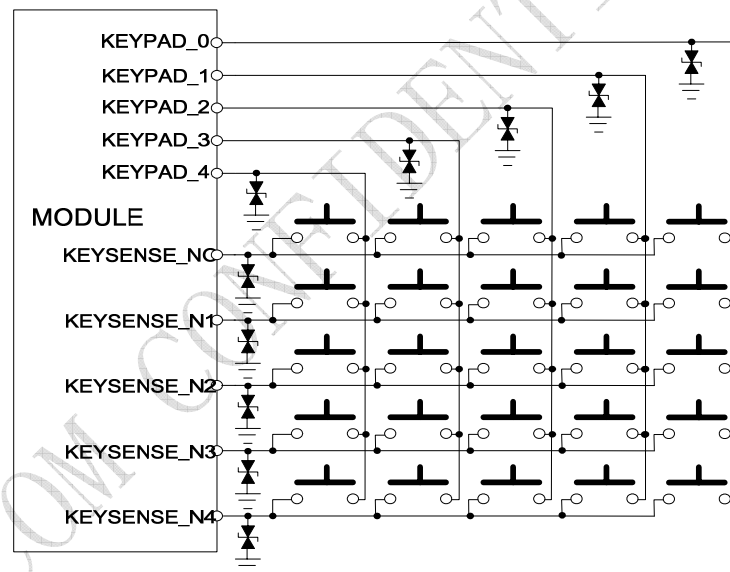

Figure 29: Reference circuit

If these pins are configured for GPIOs, the sequence is listed in the following table.

Table 20: GPIO configuration

Keypad interface	GPIO No.
KEYPAD_4	GPIO6
KEYPAD_3	GPIO7
KEYPAD_2	GPIO8
KEYPAD_1	GPIO9
KEYPAD_0	GPIO10
KEYSENSE_N4	GPIO11
KEYSENSE_N 3	GPIO12
KEYSENSE_N 2	GPIO13
KEYSENSE_N 1	GPIO14
KEYSENSE_N 0	GPIO15

Note: Refer to document [23] for detailed information of Keypad Application Note.

3.8 USB Interface

SIM5320A module contains a USB interface. This interface is compliant with the USB2.0 specification. The USB2.0 specification requires hosts such as the computer to support all three USB speeds, namely low-speed (1.5Mbps), full-speed (12Mbps) and high-speed (480Mbps). USB charging and USB-OTG is not supported.

Table 21: Electronic characteristic

Pin name	Pin No.	Input voltage scope(V)		
		Min	Typ	Max
USB_VBUS	11	4.4	5.0	5.25
USB_DP	13	They are compliant with the USB 2.0 specification.		
USB_DM	12			

3.8.1 Application Guide

Currently SIM5320A supports the USB suspend and resume mechanism which can help to save power. If no transaction is on USB bus, SIM5320A will enter suspend mode. When some events such as voice call or receiving SMS happen, SIM5320A will resume normal mode automatically.

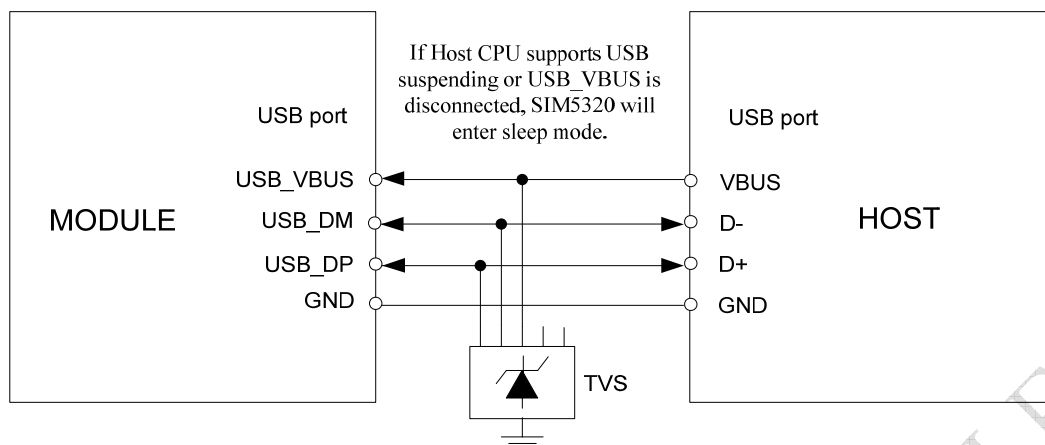

Figure 30: USB interface

Because of high bit rate on USB bus, pay attention to influence of junction capacitance of ESD component on USB data lines. Typically, the capacitance should be less than 4pF @1MHz.

Note: The SIM5320A has two kinds of interface (UART and USB) to connect to host CPU. USB interface is mapped to five virtual ports: “SIMTECH USB Modem”, “SIMTECH NMEA Device”, “SIMTECH ATCOM Device”, “SIMTECH Diagnostics interface” and “SIMTECH Wireless Ethernet Adapter”.

3.9 SPI Interface

SPI interface of SIM5320A is master only. It provides a duplex, synchronous, serial communication link with peripheral devices. Its operation voltage is 1.8V, with clock rates up to 26 MHz.

3.9.1 Pin Description

Table 22: Electronic characteristic

Pin name	1.8V mode		
	Min	Typ	Max
SPI_CLK	1.65	1.8	1.95
SPI_CS_N	1.65	1.8	1.95
SPI_MOMI_DATA	1.65	1.8	1.95
SPI_MIMO_DATA	1.65	1.8	1.95

Table 23: Pin description

Pin name	Pin No.	Function
SPI_CS	9	SPI chip-select; not mandatory in a point-to-point connection
SPI_MISO_DATA	7	SPI master in/slave out data
SPI_CLK	6	SPI clock
SPI_MOSI_DATA	8	SPI master out/slave in data

3.10 GPIO Interface

SIM5320A provides a limited number of GPIO pins. All GPIOs can be configured as inputs or outputs. User can use AT Commands to read or write GPIOs status. Refer to ATC document for details.

3.10.1 Pin Description

Table 24: Electronic characteristic

Pin name	2.6V mode		
	Min	Typ	Max
GPIO1	2.5	2.6	2.7
GPIO4	2.5	2.6	2.7
GPIO40	2.5	2.6	2.7
GPIO41	2.5	2.6	2.7
GPIO43	2.5	2.6	2.7
GPIO44	2.5	2.6	2.7
GPIO42	2.5	2.6	2.7

Note: If more GPIOs need to be used, users can configure GPIO on other multiple function interfaces, such as PCM. Please refer to GPIO list.

Table 25: Pin description

Pin name	Pin No.	I/O	Function
GPIO1	51	O	Output PIN as LED control for network status. If it is unused, left open.
GPIO4	49	I	Input PIN as RF operating control. H: Normal Mode L:Flight Mode If it is unused, left open.
GPIO40	54	O	Output PIN as operating status indicating of module. H: Power on L: Power off If it is unused, left open.
GPIO41	52	I/O	General input/output PIN. It can be used as wake/interrupt signal to host from module If it is unused, left open.
GPIO42	53	I/O	General Purpose Input/Output Port.
GPIO43	50	I/O	General Purpose Input/Output Port. It can be used as wake/interrupt signal to module from host. If it is unused, left open.
GPIO44	48	I/O	General Purpose Input/Output Port

Note: The output driver current of GPIOs is 1mA at the lower supply voltage and 2mA at the higher supply voltage.

3.10.2 Application Guide

Network status

GPIO1 is used to control Network Status LED; application circuit is shown below.

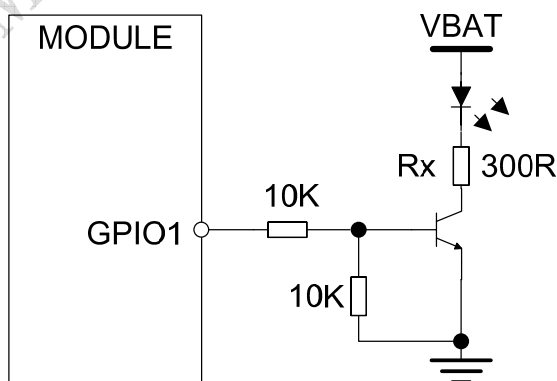

Figure 31: Application circuit

Note: The value of resistor Rx depends on LED characteristic.

Table 26: LED status

LED Status	Module Status
Always On	Searching Network/Call Connect
200ms ON, 200ms OFF	Data Transmit
800ms ON, 800ms OFF	Registered network
Off	Power off / Sleep

Flight mode control

GPIO4 controls SIM5320A module to enter or exit the Flight mode. In Flight mode, SIM5320A closes RF function to prevent interference with other equipments or minimize current consumption. Bidirectional ESD protection component is suggested to add on GPIO4.

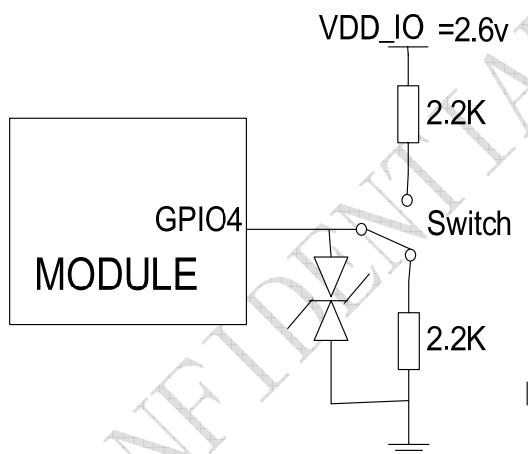

Figure 32: Flight mode switch

Table 27: Control status

GPIO4 Status	Module operation
Low Level	Flight Mode: RF is closed.
High Level	Normal Mode: RF is working.

Note: 1. For SIM5320A, GPIO0, GPIO2, GPIO3 and GPIO5 have multiplex function, user can use them as PCM interface to connect extend codec. Refer to section 3.10 and document [1] for details.

2. When the module is powered off, make sure all digital interfaces (PCM UART, etc) connected with peripheral devices have no voltage higher than 0.3V. If users' design cannot meet above conditions, high level voltages maybe occur in GPIO pins because current leakage from above digital interfaces may occur.

3.11 PCM Interface

SIM5320A provides hardware PCM interface for external codec. The PCM interface enables communication with an external codec to support hands-free applications. SIM5320A PCM interface can be used in two modes: the default mode is auxiliary PCM (8 KHz long sync mode at 128 KHz PCM CLK); the other mode is primary PCM (8 KHz short sync mode at 2048 KHz PCM CLK). In short-sync (primary PCM) mode, SIM5320A can be a master or a slave. In long-sync (auxiliary PCM) mode, SIM5320A is always a master. SIM5320A also supports 3 kinds of coding formats: 8 bits (μ-law or A-law) and 16 bits (linear).

Note: PCM interface is multiplexed from GPIO (default setting). The AT command “AT+CPCM” is used to switch between PCM and GPIO functions. Please refer to document [22] and document [1] for details.

3.11.1 Pin Description

Table 28: Electronic characteristic

Pin name	2.6V mode		
	Min	Typ	Max
PCM_CLK	2.5	2.6	2.7
PCM_SYNC	2.5	2.6	2.7
PCM_DOUT	2.5	2.6	2.7
PCM_DIN	2.5	2.6	2.7

Table 29: Pin description

Pins	Pin No.	AUX_PCM functionality	Primary PCM functionality	Description
PCM_DIN/GPIO0	74	AUX_PCM_DIN	PCM_DIN	PCM data input
PCM_SYNC/GPIO2	75	AUX_PCM_SYNC	PCM_SYNC	PCM data synchrony
PCM_DOUT/GPIO5	73	AUX_PCM_DOUT	PCM_DOUT	PCM data output
PCM_CLK/GPIO3	76	AUX_PCM_CLK	PCM_CLK	PCM data clock

3.11.2 Signal Description

The default PCM interface in SIM5320A is the auxiliary PCM interface. The data changes on the high level of PCM_CLK and is sampled at the falling edge of PCM_CLK in one period. Primary PCM is disabled after every power-on or every reset event. So user must use AT command to enable the primary

PCM mode after powering on or resetting the module every time if user wants to use Primary PCM. SIM5320A PCM Interface can be operated in Master or Slave mode if it is configured to primary PCM. In Master Mode, the Module drives the clock and sync signals that are sent to the external codec. When it is in Slave Mode, the external codec drives the clock and sync signals which are sent to the module. Both PCM modes are discussed in this section followed by additional PCM topics.

Auxiliary PCM (128 KHz PCM clock)

u-law coding is supported by the auxiliary PCM. The auxiliary codec port operates with standard long-sync timing and a 128 KHz clock. The AUX_PCM_SYNC runs at 8 KHz with 50% duty cycle. Most u-law codec support the 128 KHz clock.

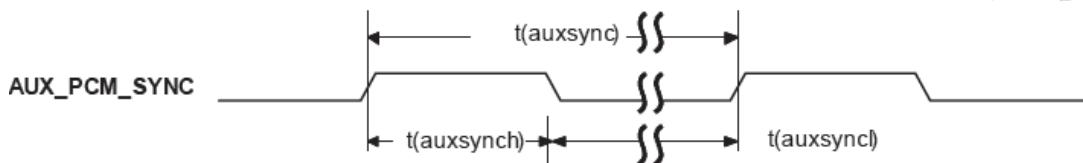

Figure 33: Synchrony timing

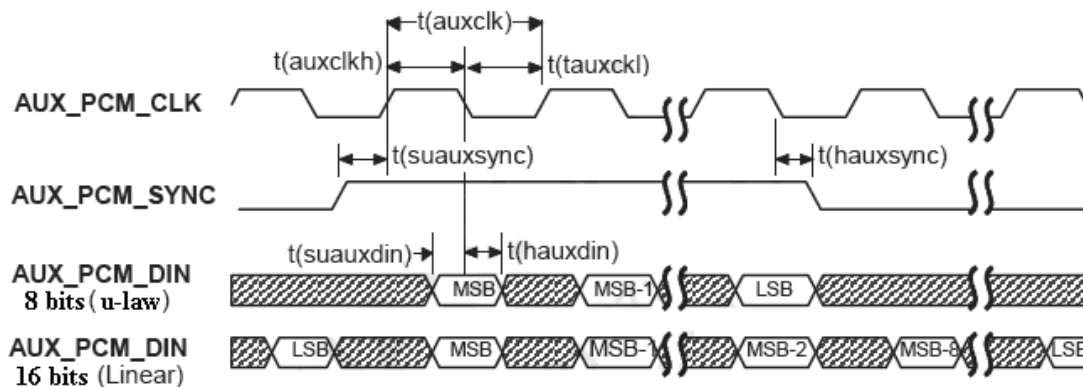

Figure 34: EXT CODEC to MODULE timing

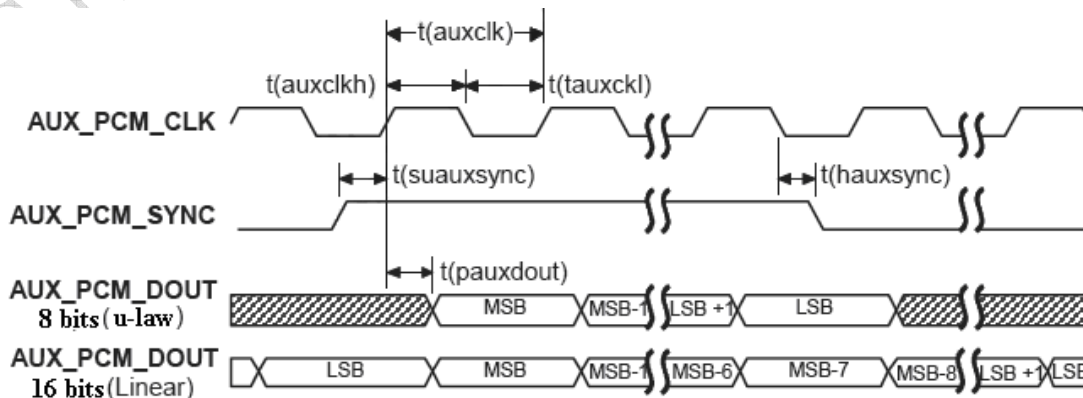

Figure 35: MODULE to EXT CODEC timing

Table 30: Timing parameters

Parameter	Description	Min	Typ	Max	Unit
T(auxsync)	AUX_PCM_SYNC cycle time	–	125	-	μs
T(auxsynch)	AUX_PCM_SYNC high time	62.4	62.5	-	μs
T(auxsyncl)	AUX_PCM_SYNC low time	62.4	62.5	-	μs
T(auxclk)*	AUX_PCM_CLK cycle time	-	7.8	–	μs
T(auxclkh)	AUX_PCM_CLK high time	3.8	3.9	–	μs
T(auxclkl)	AUX_PCM_CLK low time	3.8	3.9	–	μs
T(suauxsync)	AUX_PCM_SYNC setup time high before falling edge of PCM_CLK	1.95	–	–	μs
T(hauxsync)	AUX_PCM_SYNC hold time after falling edge of PCM_CLK	1.95	–	–	μs
T(suauxdin)	AUX_PCM_DIN setup time before falling edge of AUX_PCM_CLK	70	–	–	ns
T(hauxdin)	AUX_PCM_DIN hold time after falling edge of AUX_PCM_CLK	20	–	–	ns
T(pauxdout)	Delay from AUX_PCM_CLK rising to AUX_PCM_DOUT valid	–	–	50	ns

*Note: $T(\text{auxclk}) = 1/(128 \text{ KHz})$.

Primary PCM (2048 KHz PCM clock)

SIM5320A also supports 2.048 MHz PCM data and sync timing for v-law codec. This is called the primary PCM interface. User can use AT command to take the mode you want as discussed above.

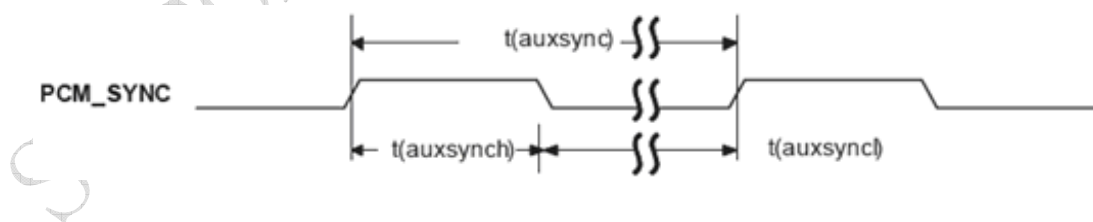

Figure 36: Synchrony timing

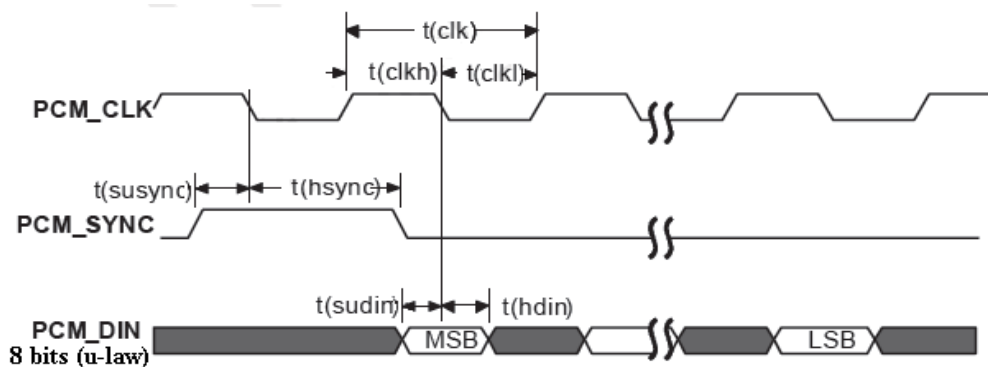

Figure 37: EXT CODEC to MODULE timing

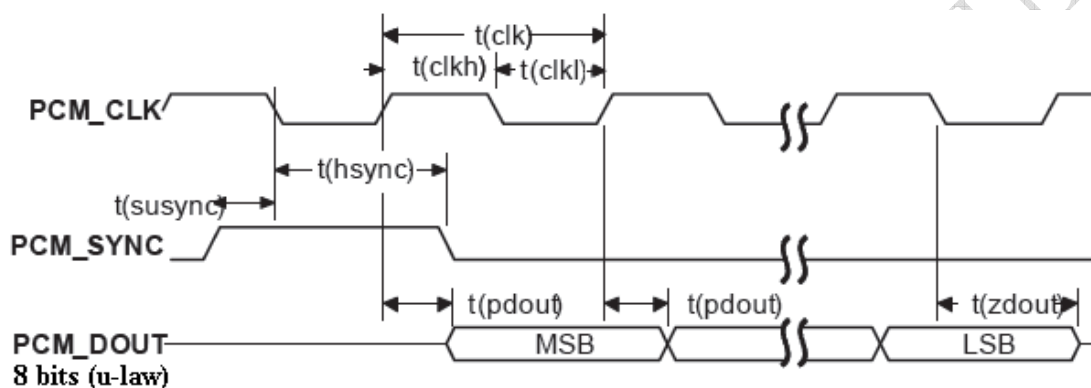

Figure 38: MODULE to EXT CODEC timing

Table 31: Timing parameters

Parameter	Description	Min	Typ	Max	Unit
T(sync)	PCM_SYNC cycle time	–	125	–	μs
T(synch)	PCM_SYNC high time	400	500	–	ns
T(sync _l)	PCM_SYNC low time	–	124.5	–	μs
T(clk)	PCM_CLK cycle time	–	488	–	ns
T(clkh)	PCM_CLK high time	–	244	–	ns
T(clkl)	PCM_CLK low time	–	244	–	ns
T(susync)	PCM_SYNC setup time high before falling edge of PCM_CLK	60	–	–	ns
T(hsync)	PCM_SYNC hold time after falling edge of PCM_CLK	60	–	–	ns
T(sudin)	PCM_DIN setup time before falling edge of PCM_CLK	50	–	–	ns
T(hdin)	PCM_DIN hold time after falling edge of PCM_CLK	10	–	–	ns
T(pdout)	Delay from PCM_CLK rising to PCM_DOUT valid	–	–	350	ns

T(zdout)	Delay from PCM_CLK falling to PCM_DOUT HIGH-Z	–	160	–	ns
----------	---	---	-----	---	----

Note: SIM5320A can transmit PCM data by USB except for PCM interface. Please refer to document [22] for more information of PCM Application Note.

3.12 Global Positioning System

SIM5320A merges GPS satellite and network information to provide a high-availability solution that offers industry-leading accuracy and performance. This solution performs well, even in very challenging environmental conditions where conventional GPS receivers fail, and provides a platform to enable wireless operators to address both location-based services and emergency mandates.

3.12.1 Technical specification

Tracking sensitivity	-157 dBm
Cold-start sensitivity	-144 dBm
Accuracy (Open Sky)	<2m (CEP50)
TTFB (Open Sky)	Hot start <1s Cold start 35s (good signal)/ 100s(weak signal)
Receiver Type	12-channel, GPS L1 Frequency (1575.42MHz), C/A Code
Update rate	Default 1 Hz
GPS data format	NMEA-0183
GPS Current consumption (WCDMA/GSM Sleep mode)	100mA (Total supply current)
GPS antenna	Passive/Active antenna

Note: Performance will vary depending on the environment, antenna type and signal conditions and so on.

3.12.2 Operate Mode

SIM5320A supports both A-GPS and S-GPS, and then provides three operating modes: mobile-assisted mode, mobile-based mode and standalone mode. A-GPS includes mobile-assisted and mobile-based mode.

In mobile-assisted mode, when a request for position location is issued, available network information is provided to the location server (e.g. Cell-ID) and assistance is requested from the location server. The location server sends the assistance information to the handset. The handset/mobile unit measures the GPS observables and provides the GPS measurements along with available network data (that is appropriate for the given air interface technology) to the location server. The location server then calculates the position location and returns results to the requesting entity.

In mobile-based mode, the assistant data provided by the location server encompasses not only the information required to assist the handset in measuring the satellite signals, but also the information required to calculate the handset's position. Therefore, rather than provide the GPS measurements and

available network data back to the location server, the mobile calculates the location on the handset and passes the result to the requesting entity.

In standalone (autonomous) mode, the handset demodulates the data directly from the GPS satellites. This mode has some reduced cold-start sensitivity, and a longer time to first fix as compared to the assisted modes. However, it requires no server interaction and works out of network coverage.

This combination of GPS measurements and available network information provides:

- High-sensitivity solution that works in all terrains: Indoor, outdoor, urban, and rural
- High availability that is enabled by using both satellite and network information

Therefore, while network solutions typically perform poorly in rural areas and areas of poor cell geometry/density, and while unassisted, GPS-only solutions typically perform poorly indoors. The SIM5320A GPS solution provides optimal time to fix, accuracy, sensitivity, availability, and reduced network utilization in both of these environments, depending on the given condition.

3.12.3 Application Guide

Users can adopt an active antenna or a passive antenna as GPS signal transceiver. In this document, all GPS specification mentioned is from passive antenna. The following is the reference circuit.

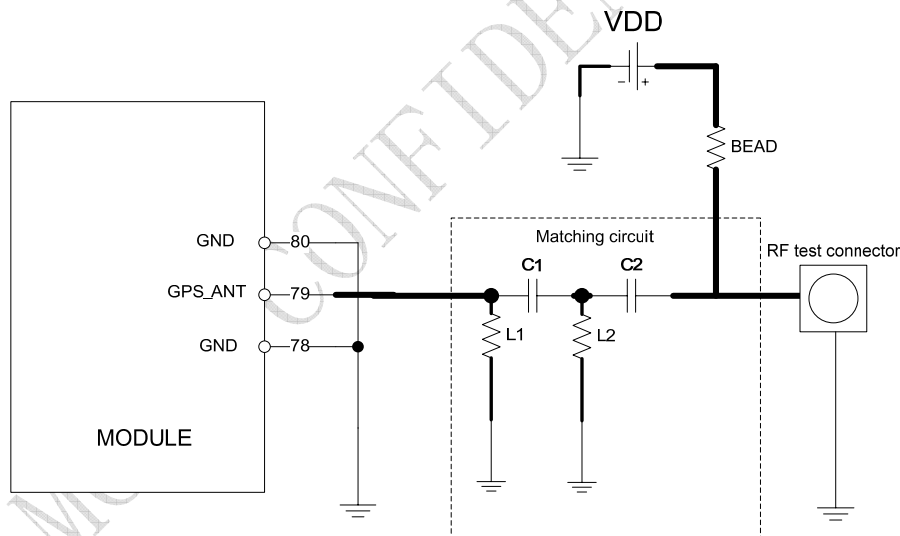

Figure 39: Active antenna circuit

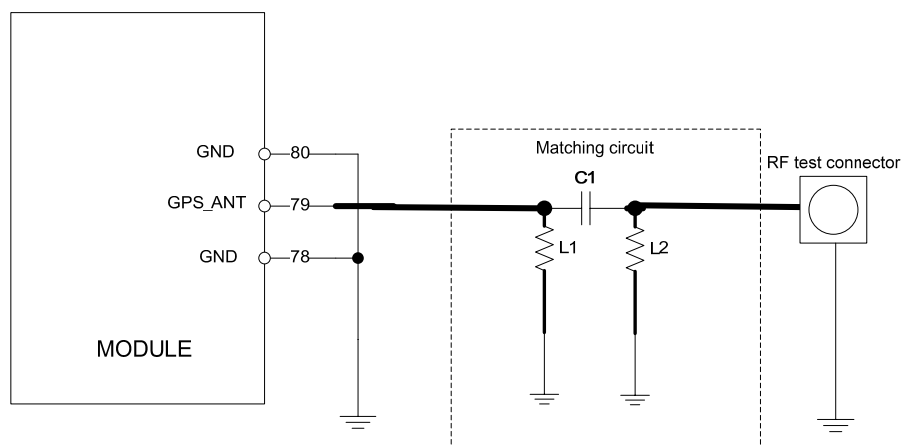

Figure 40: Passive antenna circuit (Default)

In above figures, the components C1 and L1, L2 are used for antenna matching, the values of the components can only be obtained after the antenna tuning usually, and they are provided by antenna vendor. C2 in Figure 39 is used for DC isolation. In active antenna circuit, users must use an external LDO/DCDC to provide VDD voltage whose value should be taken according active antenna characteristic, and VDD can be shut down to avoid consuming additional current when not being used.

GPS can be used by NMEA port. User can select NMEA as output through UART or USB. NMEA sentences are automatic and no command is provided. NMEA sentences include GSV, GGA, RMC, GSA, and VTG. Before using GPS, user should configure SIM5320A in proper operating mode by AT command. Please refer to related document for details. SIM5320A can also get position location information through AT directly.

Note: GPS is closed by default, it could be started by AT+CGPS. The AT command has two parameters, the first is on/off, and the second is GPS mode. Default mode is standalone mode.

AGPS mode needs more support from the mobile telecommunication network. Refer to AGPS application document for details.

3.13 Multi-functional interface

SIM5320A merges functions for various applications. It can enrich users' design and lower the cost of users' hardware.

3.13.1 Sink Current Source

The dedicated pin (CURRENT_SINK) is intended for driving passive devices, such as LCD backlight, this implementation is +5V tolerant and suitable for driving white LEDs. The high-current driver can maintain a constant current which is set by the AT command "AT+ CLEDITST", capable of up to 150 mA.

Table 32: Electronic characteristic

Symbol	Description	Min	Typ	Max	Unit
CURRENT_SINK	Input voltage	0.5	VDD	5	V
I _O	Input current	-	-	150	mA

Since the driver is ground-referenced current sink, the operating device it drives must form a current path between the VDD pin and the CURRENT_SINK pin. The following figure is for users reference.

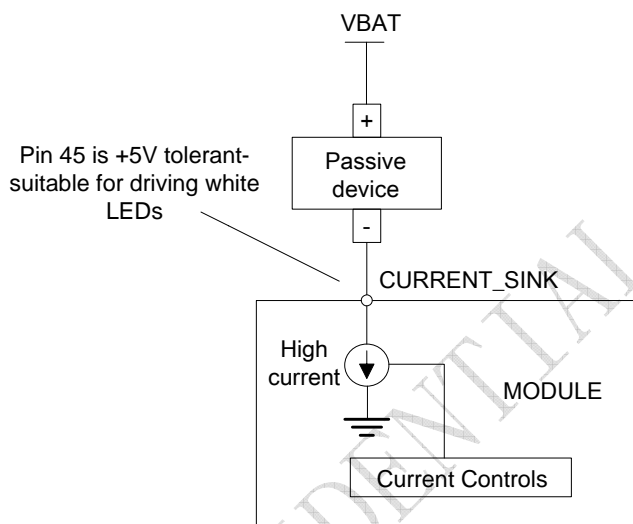

Figure 41: Current drive

Note: The sinking current can be adjusted to meet design requirement through the AT command “AT+ CLEDITST =<0>, <value>”. The “value” ranges from 0 to 15, on behalf of the current changes from 0mA to 150mA in steps of 10mA.

3.13.2 Reset Function

SIM5320A also have a RESET pin (PIN4) to reset the module. This function is used as an emergency reset only when AT command “AT+CPOF” and the POWER_ON pin has no effect. User can pull the RESET pin to ground, then the module will reset.

This pin is already pulled up in module, so the external pull-up resistor is not necessary. A 100nF capacitor close to the RESET pin is strongly recommended. A reference circuit is recommended in the following figure.

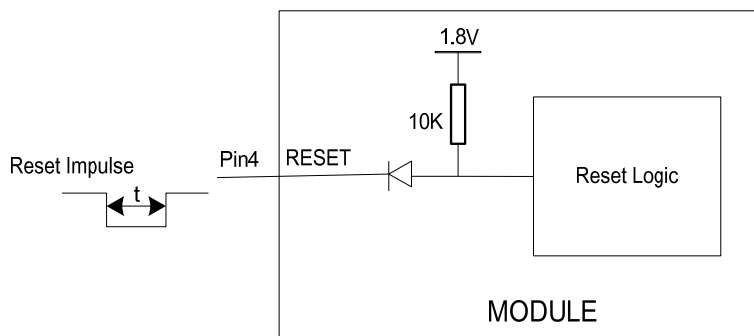

Figure 42: Reset circuit

Note: $50ms < t < 200ms$. ESD components are suggested to be used on Reset pin.

3.13.3 ADC

SIM5320A has a dedicated ADC that is available for digitizing analog signals such as battery voltage and so on; it is on PIN 47, namely ADC1. This ADC1 is 8 bit successive-approximation circuit, and electronic specification is shown in the following table.

Table 33: Electronic Characteristics

Specification	Min	Typ	Max	Unit	Comments/Conditions
Resolution		8		Bits	
Differential nonlinearity	-4		+4	LSB	Analog Vdd = ADC reference 2.4MHz sample rate
Integral nonlinearity	-8		+8	LSB	
Gain Error	-2.5		+2.5	%	
Offset Error	-4		+40	LSB	
Input Range	GND		2.2V	V	
Input serial resistance		2		kΩ	Sample and hold switch resistance
Input capacitance		53		pF	
Power-down to wakeup		9.6	19.2	μs	

User can introduce a signal in the ADC pin directly and use the AT command “AT+CADC” to get the raw data which is between 0 and 255. The data can be transformed to any type such as voltage, temperature etc. Please refer to Chapter 3.1.2 and document [1].

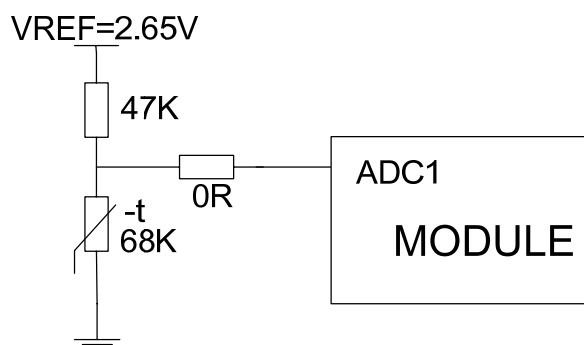

Figure 43: Reference circuit

Note: The input signal voltage value in ADC must not be higher than 2.2V.

3.13.4 LDO

SIM5320A has a LDO power output, namely VREG_AUX. The LDO is available and output voltage is 2.85v by default, rated for 250mA. User can switch the LDO on or off by the AT command “AT+CVAUXS” and configure its output voltage by the AT command “AT+CVAUXV”.

Table 34: Electronic characteristic

Symbol	Description	Min	Typ	Max	Unit
VREG_AUX	Output voltage	1.5	2.85	3.05	V
I _O	Output current	-	-	250	mA

4 RF Specification

4.1 RF Specification

Table 35: Conducted transmission power

Frequency	Max	Min
GSM850	33dBm ±2dB	5dBm ± 5dB
E-GSM900	33dBm ±2dB	5dBm ± 5dB
DCS1800	30dBm ±2dB	0dBm ± 5dB
PCS1900	30dBm ±2dB	0dBm ± 5dB
GSM850 (8-PSK)	27dBm ±3dB	5dBm ± 5dB
E-GSM900 (8-PSK)	27dBm ±3dB	5dBm ± 5dB
DCS1800 (8-PSK)	26dBm +3/-4dB	0dBm ±5dB
PCS1900(8-PSK)	26dBm +3/-4dB	0dBm ±5dB
WCDMA 2100	24dBm +1/-3dB	-56dBm ±5dB
WCDMA 1900	24dBm +1/-3dB	-56dBm ±5dB
WCDMA 850	24dBm +1/-3dB	-56dBm ±5dB
WCDMA 900	24dBm + 1/-3dB	-56dBm ±5dB

Table 36: Operating frequencies

Frequency	Receiving	Transmission
GSM850	869 ~894 MHz	824 ~849 MHz
E-GSM900	925 ~960 MHz	880 ~915 MHz
DCS1800	1805~1880 MHz	1710~1785 MHz
PCS1900	1930~1990 MHz	1850~1910 MHz
WCDMA 2100	2110~2170 MHz	1920~1980 MHz
WCDMA1900	1930~1990 MHz	1850~1910 MHz
WCDMA 850	869 ~894 MHz	824 ~849 MHz
WCDMA 900	925 ~960 MHz	880 ~915 MHz

Table 37: Conducted receive sensitivity

Frequency	Receive sensitivity
GSM850	< -106dBm
E-GSM900	< -106dBm
DCS1800	< -106dBm
DCS1800	< -106dBm
WCDMA 2100	< -108dBm
WCDMA 1900	< -108dBm
WCDMA 850	< -106dBm
WCDMA 900	< -106dBm

4.2 Operating Specification

SIM5320A can support high rate data by GSM/WCDMA wireless network. In the different network environment, data transmission rate shifts depending on modulation and encoding.

Table 38: GPRS/EDGE data throughput

Function	Coding schemes	1 Timeslot	2 Timeslot	4 Timeslot
GPRS	CS-1	9.05kbps	18.1kbps	36.2kbps
	CS-2	13.4kbps	26.8kbps	53.6kbps
	CS-3	15.6kbps	31.2kbps	62.4kbps
	CS-4	21.4kbps	42.8kbps	85.6kbps
EDGE	MCS-1	8.80kbps	17.6kbps	35.20kbps
	MCS-2	11.2kbps	22.4kbps	44.8kbps
	MCS-3	14.8kbps	29.6kbps	59.2kbps
	MCS-4	17.6kbps	35.2kbps	70.4kbps
	MCS-5	22.4kbps	44.8kbps	89.6kbps
	MCS-6	29.6kbps	59.2kbps	118.4kbps
	MCS-7	44.8kbps	89.6kbps	179.2kbps
	MCS-8	54.4kbps	108.8kbps	217.6kbps
	MCS-9	59.2kbps	118.4kbps	236.8kbps

Table 39: HSDPA throughput

Category	Supported	Max supported HS-DSCH codes	Theoretical max peak rate(Mbps)	Modulation
Category1		5	1.2	16QAM,QPSK
Category2		5	1.2	16QAM,QPSK
Category3		5	1.8	16QAM,QPSK
Category4		5	1.8	16QAM,QPSK
Category5	✓	5	3.6	16QAM,QPSK
Category6	✓	5	3.6	16QAM,QPSK
Category7		10	7.2	16QAM,QPSK
Category8		10	7.2	16QAM,QPSK
Category9		15	10.0	16QAM,QPSK
Category10		15	14.0	16QAM,QPSK
Category11		5	0.9	QPSK
Category12	✓	5	1.8	QPSK

Note: Actual throughput rates depend on network configuration, network loading, signal condition and so on.

4.3 Antenna Design Guide

SIM5320A provides RF antenna interface. Customer's antenna should be located in the host board and connected to module's antenna pad through micro-strip line or other types of RF trace and the trace impedance must be controlled in 50Ω. SIMCom recommends that the total insertion loss between the antenna pad and antenna should meet the following requirements:

- GSM900/GSM850<0.5dB
- DCS1800/PCS1900 <0.9dB
- WCDMA 2100/1900<0.9dB
- WCDMA 900/850<0.5dB

To facilitate the antenna tuning and certification test, a RF connector and an antenna matching circuit should be added. The following figure is the recommended circuit.

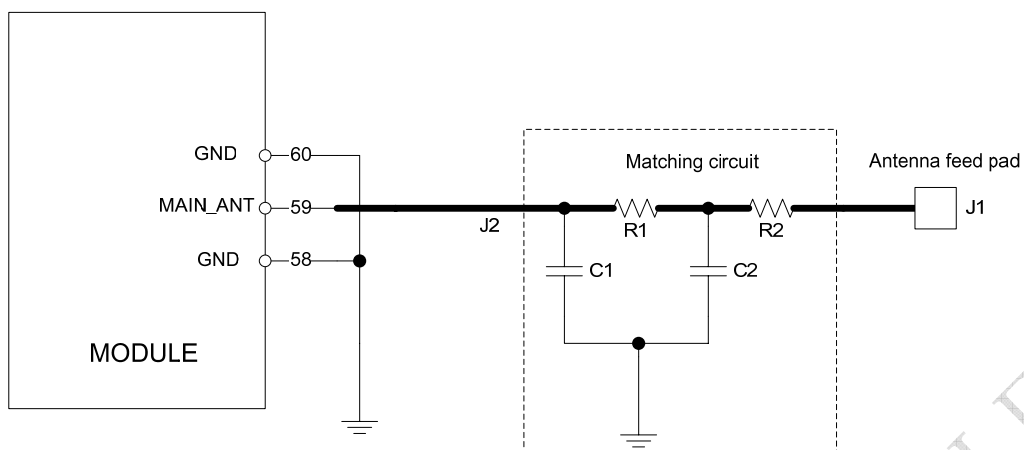

Figure 44: Antenna matching circuit

In this figure, the components R1, C1, C2 and R2 is used for antenna matching, the value of components can only be got after the antenna tuning, usually, they are provided by antenna vendor. By default, the R1, R2 are 0 ohm resistors, and the C1, C2 are reserved for tuning.

The RF test connector in the figure is used for the conducted RF performance test, and should be placed as close as to the module's antenna pin. The traces impedance between components must be controlled in 50ohm.

5 Reliability and Operating Characteristics

5.1 Electronic Characteristics

Absolute maximum rating for digital and analog pins of SIM5320A are listed in the following table:

Table 40: Absolute maximum ratings

Parameter	Min	Max	Unit
Voltage at digital pins (1.8v mode)	-0.3	1.8+0.3	V
Voltage at digital pins (2.6v mode)	-0.3	2.6+0.3	V
Voltage at VBAT	-0.5	6.0	V
Voltage at VRTC	1.5	3.2	V
Voltage at USB_VBUS	-0.5	6.0	V

Table 41: Recommended operating ratings

Parameter	Min	Typ	Max	Unit
Voltage at digital pins (1.8v mode)	1.65	1.8	1.95	V
Voltage at digital pins (2.6v mode)	2.5	2.6	2.7	V
Voltage at VBAT	3.3	3.8	4.2	V
Voltage at VRTC	1.5	-	3.0	V
Voltage at USB_VBUS	4.75	5	5.25	V

The operating temperature and power specification is listed in the following table.

Table 42: Operating temperature

Parameter	Min	Typ	Max	Unit
Ambient temperature	-30	25	80	°C
Storage temperature	-40	25	+85	°C

Note: SIMCom recommends user to install a heat sink on the module shielding case if SIM5320A operates in WCDMA band.

5.2 Operating Mode

The following table summarizes the various operating modes, each operating modes will be referred to in the following chapters.

5.2.1 Operating Modes Overview

Table 43: Operating Modes Overview

Mode	Function	
Sleep mode	GSM/WCDMA SLEEP	Module will automatically enter SLEEP mode if DTR is set to high level and there is no on air or hardware interrupt (such as GPIO interrupt or data on serial port).
		In this case, the current consumption of module will be reduced to the minimal level. In SLEEP mode, the module can still receive paging message, voice call and SMS.
GSM	GSM IDLE	Software is active. Module has registered to the GSM network, and the module is ready to communicate.
	GSM TALK	Connection between two subscribers is in progress. In this case, the power consumption depends on network settings (DTX off/on, FR/EFR/HR, hopping sequences, etc.) and antenna.
GPRS	GPRS STANDBY	Module is ready for GPRS data transfer, but no data is currently sent or received. In this case, power consumption depends on network settings and GPRS configuration.
	GPRS DATA	There is GPRS data transfer (PPP or TCP or UDP) in progress. In this case, power consumption is related with network settings (e.g. power control level), uplink/downlink data rates and GPRS configuration (e.g. used multi-slot settings).
EDGE	EDGE STANDBY	Module is ready for data transfer in EDGE mode, but no data is currently sent or received. In this case, power consumption depends on network settings and EDGE configuration
	EDGE DATA	There is EDGE data transfer (PPP or TCP or UDP) in progress. In this case, power consumption is related with network settings (e.g. power control level), uplink/downlink data rates and EDGE configuration.
WCDMA	WCDMA IDLE	Module has registered to the WCDMA network, and the module is ready to communicate.
	WCDMA TALK	Module is active in WCDMA mode. The power consumption depends on network settings.
HSDPA	HSDPA IDLE	Module is ready for data transmission, but no data is currently sent or received. Power consumption depends on network settings and HSDPA configuration
	HSDPA DATA	There is HSDPA data transfer (PPP or TCP or UDP) in progress. In this case, power consumption is related with network settings (e.g. power control level), uplink/downlink data rates and HSDPA configuration
Power down	Module can be powered down by the AT command “AT+CPOF” or the POWER_ON pin. The power management unit shuts down the power supply of the module, only the power supply of RTC is remained. The serial interface is not accessible. Operating voltage (connected to VBAT) remains applied.	
Minimum functionality mode	The AT command “AT+CFUN” can be used to set the module to a minimum functionality mode without removing the power supply. In this mode, the RF part of the module will not work or the SIM card will not be accessible, or both will be closed, and the serial port is still accessible. The power consumption in this mode is very low.	

5.2.2 Minimize Power Consumption

There are two modes that SIM5320A achieves low power consumption.

Sleep mode

If peripheral equipments stops working, and there is no on air or hardware interrupts (such as GPIO interrupts or data on UART), SIM5320A will enter sleep mode automatically. In this mode, SIM5320A can still receive paging, voice call or SMS from network. If USB interface of SIM5320A is connected to host CPU, but host CPU does not support USB suspending, then SIM5320A will not enter sleep mode. After USB is disconnected, SIM5320A will enter sleep mode.

Note: When UART interface is connected with host CPU, SIM5320A can not enter sleep mode until RXD is pulled down by the host CPU. If the module is in the idle mode, make sure to pull the RXD to low level by host CPU. SIMCom recommends using GPIO43 or UART_DTR to wake up the module from host CPU and to use GPIO41 or UART_RI to wake up the host CPU. Before designing, pay attention to how to realize waking function and refer to Document[24] and Document[25] for more detail.

Minimum functionality mode

Minimum functionality mode ceases a majority function of module, thus minimizing the power consumption. This mode is set by the AT command which provides a choice of the functionality levels.

- AT+CFUN=0: Minimum functionality
- AT+CFUN=1: Full functionality (Default)
- AT+CFUN=4: Disable RF function of the module (Flight mode)

If SIM5320A has been set to minimum functionality mode, the module will firstly enter sleep mode, then the RF function and SIM card function will be closed. In this case, the serial port is still accessible, but RF function or SIM card will be unavailable. When SIM5320A is in minimum functionality or flight mode, it can return to full functionality by the AT command “AT+CFUN=1”.

Note: For flight mode, please refer to Chapter 2.12.2.

5.3 Current Consumption

The current consumption in suspended mode and without USB connection is listed in the table below. Here, “suspended mode” means that SIM5320A is connected to USB bus, but it does not transfer data.

Table 44: Current consumption

GSM Sleep mode (without USB connection)	
GSM850	Sleep @DRX=2 4.5mA
	Sleep @DRX=5 2.7mA
	Sleep @DRX=9 2.3mA
GSM900	Sleep @DRX=2 4.5mA
	Sleep @DRX=5 2.7mA
	Sleep @DRX=9 2.3mA
DCS1800	Sleep @DRX=2 4.5mA
	Sleep @DRX=5 2.7mA
	Sleep @DRX=9 2.3mA
PCS1900	Sleep @DRX=2 4.5mA
	Sleep @DRX=5 2.7mA
	Sleep @DRX=9 2.3mA
GSM Sleep Mode (with USB suspended)	
GSM850	Sleep @DRX=2 4.6mA
	Sleep @DRX=5 2.8mA
	Sleep @DRX=9 2.5mA
GSM900	Sleep @DRX=2 4.6mA
	Sleep @DRX=5 2.8mA
	Sleep @DRX=9 2.5mA
DCS1800	Sleep @DRX=2 4.6mA
	Sleep @DRX=5 2.8mA
	Sleep @DRX=9 2.5mA
PCS1900	Sleep @DRX=2 4.6mA
	Sleep @DRX=5 2.8mA
	Sleep @DRX=9 2.5mA
Voice Call	
GSM850	@power level #5 <300mA, Typical 305mA
GSM 900	@power level #5 <300mA, Typical 305mA
DCS1800	@power level #0 <250mA, Typical 237mA
PCS1900	@power level #0 <250mA, Typical 237mA
GPRS Data	
DATA mode, GPRS (1 Rx,4 Tx) CLASS 12	
GSM 850	@power level #5 <660mA, Typical 488mA
GSM 900	@power level #5 <660mA, Typical 484mA
DCS1800	@power level #0 <530mA, Typical 346mA
PCS1900	@power level #0 <530mA, Typical 353mA
DATA mode, GPRS (3Rx, 2 Tx) CLASS 12	
GSM 850	@power level #5 <460mA, Typical 335mA
GSM 900	@power level #5 <440mA, Typical 332mA
DCS1800	@power level #0 <400mA, Typical 260mA
PCS1900	@power level #0 <300mA, Typical 263mA

EDGE Data	
DATA mode, EDGE(1 Rx,4 Tx) CLASS 12	
GSM 850	@power level #8 <500mA, Typical 335mA
GSM 900	@power level #8 <500mA, Typical 332mA
DCS1800	@power level #2 <450mA, Typical 291mA
PCS1900	@power level #2 <450mA, Typical 293mA
DATA mode, EDGE(3Rx, 2 Tx) CLASS 12	
GSM 850	@power level #8 <330mA, Typical 235mA
GSM 900	@power level #8 <330mA, Typical 231mA
DCS1800	@power level #2 <300mA, Typical 206mA
PCS1900	@power level #2 <300mA, Typical 209mA
UMTS Sleep Mode (without USB connection)	
WCDMA 2100	Sleep @DRX=9 2.2mA
	Sleep @DRX=8 2.7 mA
	Sleep @DRX=6 4.7mA
WCDMA 1900	Sleep @DRX=9 2.2mA
	Sleep @DRX=8 2.7 mA
	Sleep @DRX=6 4.7mA
WCDMA 850	Sleep @DRX=9 2.2mA
	Sleep @DRX=8 2.7 mA
	Sleep @DRX=6 4.7mA
WCDMA 900	Sleep @DRX=9 2.2mA
	Sleep @DRX=8 2.7 mA
	Sleep @DRX=6 4.7mA
UMTS Sleep Mode (with USB suspended)	
WCDMA 2100	Sleep @DRX=9 2.4mA
	Sleep @DRX=8 2.8 mA
	Sleep @DRX=6 4.8mA
WCDMA 1900	Sleep @DRX=9 2.4mA
	Sleep @DRX=8 2.8 mA
	Sleep @DRX=6 4.8mA
WCDMA 850	Sleep @DRX=9 2.4mA
	Sleep @DRX=8 2.8 mA
	Sleep @DRX=6 4.8mA
WCDMA 900	Sleep @DRX=9 2.4mA
	Sleep @DRX=8 2.8 mA
	Sleep @DRX=6 4.8mA
UMTS Talk	
WCDMA 2100	@Power 23dBm Typical 539mA
	@Power 21dBm Typical 461mA
	@Power 10dBm Typical 195mA
WCDMA 1900	@Power 23dBm Typical 604mA
	@Power 21dBm Typical 507mA
	@Power 10dBm Typical 195mA
WCDMA 850	@Power 23dBm Typical 517mA
	@Power 21dBm Typical 419mA

	@Power 10dBm	Typical 189mA
WCDMA 900	@Power 23dBm	Typical 524mA
	@Power 21dBm	Typical 417mA
	@Power 10dBm	Typical 179mA
HSDPA Data		
WCDMA 2100	@Power 23dBm CQI=22	Typical 550mA
	@Power 21dBm CQI=5	Typical 520mA
	@Power -5dBm CQI=22	Typical 270mA
WCDMA 1900	@Power 23dBm CQI=22	Typical 610mA
	@Power 21dBm CQI=5	Typical 540mA
	@Power -5dBm CQI=22	Typical 270mA
WCDMA 850	@Power 23dBm CQI=22	Typical 550mA
	@Power 21dBm CQI=5	Typical 490mA
	@Power -5dBm CQI=22	Typical 220mA
WCDMA 900	@Power 23dBm CQI=22	Typical 550mA
	@Power 21dBm CQI=5	Typical 490mA
	@Power -5dBm CQI=22	Typical 220mA

5.4 EMC and ESD Notes

EMC tests should be performed to detect any potential problems. Possible harmful emissions radiate by the application to the RF receiver in the receiver band. RF emissions interfere with audio input/output. It is recommended to shield the sensitive components and trace with common ground and user can add beads where necessary.

Normally SIM5320A is mounted on customer host board. Although some ESD components have been added in SIM5320A, to prevent ESD, user should put some ESD components on customers' board. The ESD components should be placed beside the connectors which human body might touch, such as SIM card holder, audio jacks, switches, keys, etc. The following table is the SIM5320A ESD measurement performance; the results are from SIMCom EVB test.

Table 45: The ESD performance measurement table (Temperature: 25°C, Humidity: 45%)

Part	Contact discharge	Air discharge
VBAT,GND	±4KV	±6KV
UART,USB	±2KV	±6KV
Antenna port	±4KV	±6KV
Other ports	±2KV	±2KV

6 Guide for Production

6.1 Top and Bottom View of SIM5320A



Figure 45: Top and bottom view of SIM5320A

These test points are only used for module manufacturing and testing. They are not for customer's application.

6.2 Typical Solder Reflow Profile

For customer convenience, SIMCom provides a typical example for a commonly used soldering profile. In final board assembly, the typical solder reflow profile will be determined by the largest component on the board, as well as the type of solder/flux used and PCB stack-up. Therefore the soldering profile shown below is only a generic recommendation and should be adjusted to the specific application and manufacturing constraints.

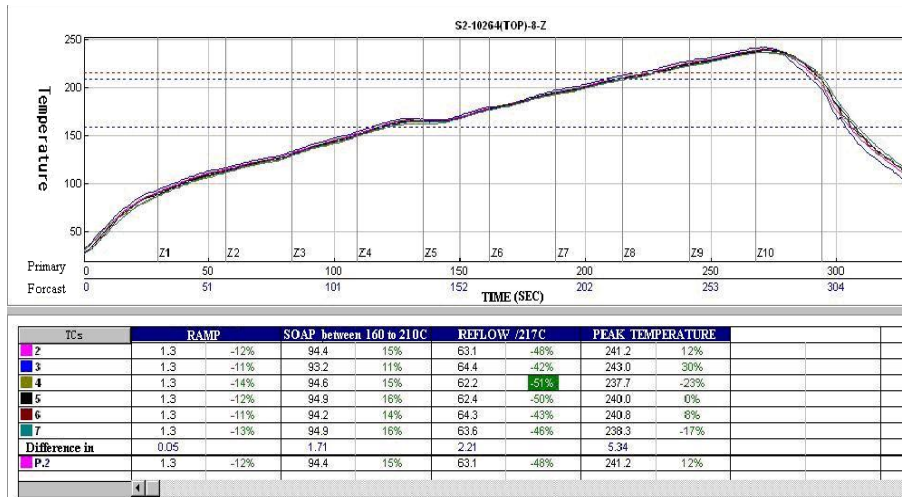

Figure 46: The ramp-soak-spike reflow profile of SIM5320A

For details about secondary SMT, please refer to *document [26]*.

6.3 Moisture Sensitivity Level (MSL)

SIM5320A is qualified to Moisture Sensitivity Level (MSL) 3 in accordance with JEDEC J-STD-020. After the prescribed time limit exceeded, users should bake modules for 192 hours in drying equipment (<5% RH) at 40° C +5° C/-0° C, or 72 hours at 85° C +5° C/-5° C. Note that plastic tray is not heat-resistant, users must not use the tray to bake at 85° C or the tray may be damaged.

6.4 Stencil Foil Design Recommendation

The recommended thickness of stencil foil is more than 0.18mm.

6.5 Recommended Pad Design

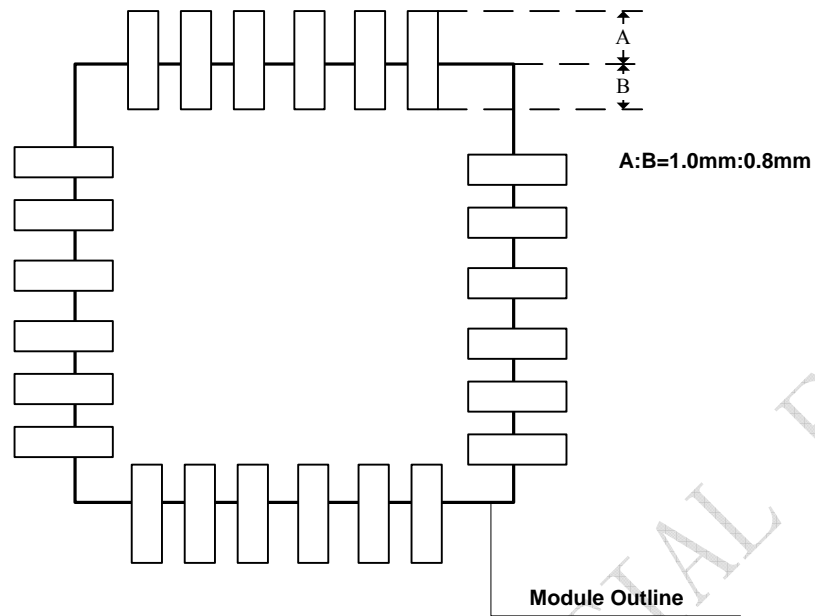

Figure 47: Recommended pad

Note: More designing details refer to Figure 6.

Appendix

A. System Design

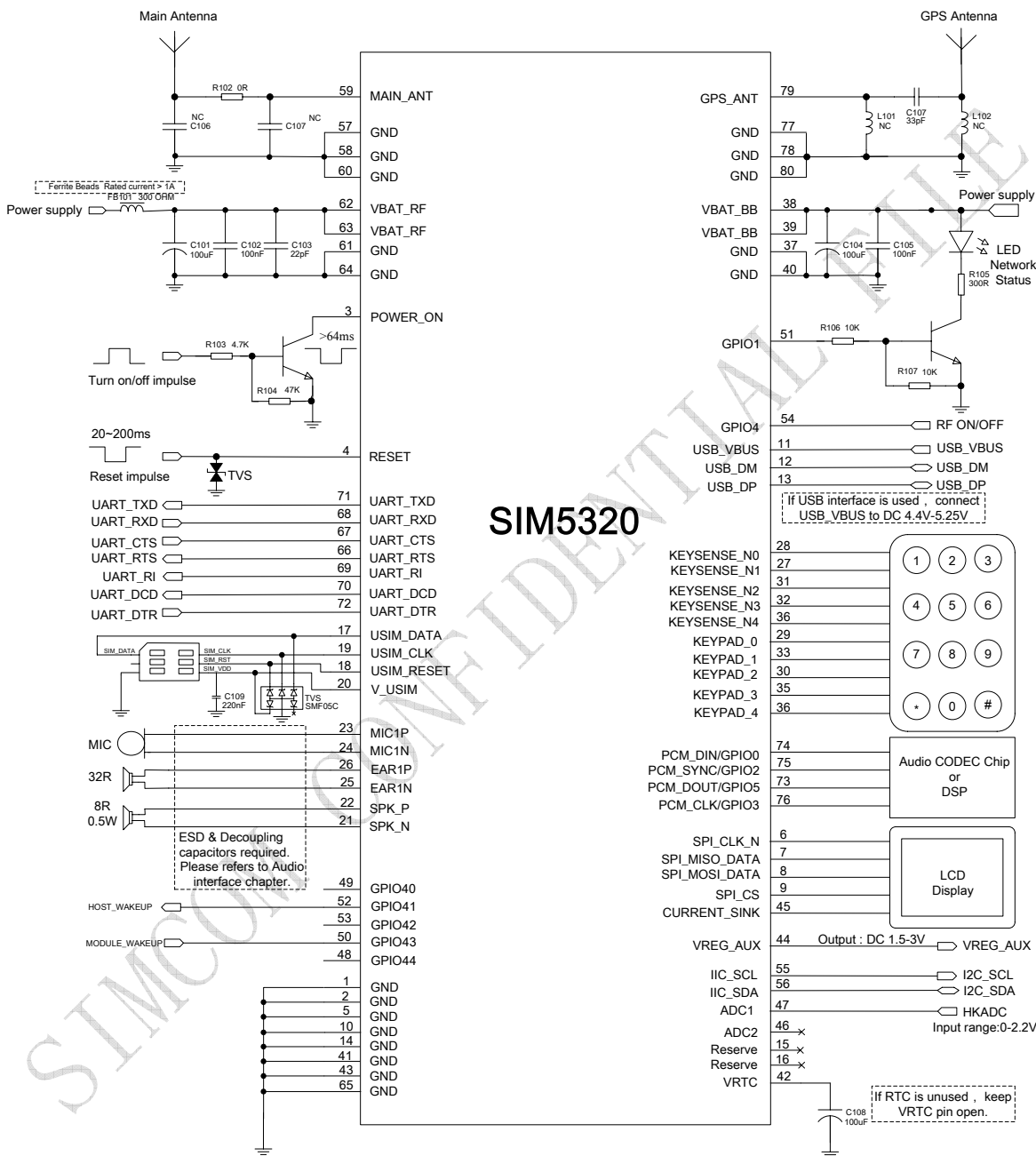

Figure 48: System design

B. SIM5320A GPIOs List

Table 46: SIM5320A GPIOs list

Name	GPIO Index	Default Function	Alternate Function
PCM_DIN	0	GPIO Interrupt [LEVEL/LOW]	PCM_DIN
STATUS_LED	1	Status led	GPIO
PCM_SYNC	2	GPIO [IN]	PCM_SYNC
PCM_CLK	3	GPIO [OUT/LOW]	PCM_CLK
RF_SWITCH	4	RF Switch	Enable/Disable RF subsystem
PCM_OUT	5	GPIO [OUT/LOW]	PCM_OUT
KEYPAD_4	6	Keypad	GPIO
KEYPAD_3	7	Keypad	GPIO
KEYPAD_2	8	Keypad	GPIO
KEYPAD_1	9	Keypad	GPIO
KEYPAD_0	10	Keypad	GPIO
KEYSENSE_N4	11	Keypad	GPIO
KEYSENSE_N3	12	Keypad	GPIO
KEYSENSE_N2	13	Keypad	GPIO
KEYSENSE_N1	14	Keypad	GPIO
KEYSENSE_N0	15	Keypad	GPIO
UART1_CTS	33	CTS	GPIO
UART1_RFR	34	RTS	GPIO
UART1_DTR	35	DTR wake up module	GPIO
UART_DCD	36	DCD	GPIO
UART_RI	37	RI wake up host	GPIO
GPIO40	40	Module power up status	GPIO
GPIO41	41	Wake up host	GPIO
GPIO42	42	GPIO	GPIO
GPIO43	43	Wake up module	GPIO
GPIO44	44	GPIO	GPIO

C. Digital I/O Characteristics

Table 47: Digital I/O characteristics

Parameter	Description	2.6V Mode			1.8V Mode			Unit
		Min	Typ	Max	Min	Typ	Max	
VREG_AUX	LDO output	0	2.6	2.9	0	1.8	1.84	V
V _{IH}	High-level input voltage	1.69	2.6	2.9	1.17	1.8	2.1	V
V _{IL}	Low-level input voltage	-0.3	0	0.91	-0.3	0	0.63	V
V _{OH}	High-level	1.17	2.6	2.6	0.81	1.8	1.8	V

	output voltage							
V _{OL}	Low-level output voltage	0	0	0.45	0	0	0.45	V
I _{IH}	Input high leakage current	-	-	1	-	-	1	uA
I _{IL}	Input low leakage current	-1	-	-	-1	-	-	uA
C _{IN}	Input capacitance	-	-	7	-	-	7	pF

Note: These parameters are for digital interface pins, such as keypad, GPIO, I²C, UART, SPI and DEBUG. The SIM5320A includes two kinds of voltages: 1.8v and 2.6v. Digital I/O specifications under both conditions are presented in the above tables.

D. Related Documents

Table 48: Related documents

SN	Document name	Remark
[1]	SIM5320A_ATC_V1.00	SIM5320A_ATC_V1.00
[2]	ITU-T Draft new recommendation V.25ter	Serial asynchronous automatic dialing and control
[3]	GSM 07.07	Digital cellular telecommunications (Phase 2+); AT command set for GSM Mobile Equipment (ME)
[4]	GSM 07.10	Support GSM 07.10 multiplexing protocol
[5]	GSM 07.05	Digital cellular telecommunications (Phase 2+); Use of Data Terminal Equipment – Data Circuit terminating Equipment (DTE – DCE) interface for Short Message Service (SMS) and Cell Broadcast Service (CBS)
[6]	GSM 11.14	Digital cellular telecommunications system (Phase 2+); Specification of the SIM Application Toolkit for the Subscriber Identity Module – Mobile Equipment (SIM – ME) interface
[7]	GSM 11.11	Digital cellular telecommunications system (Phase 2+); Specification of the Subscriber Identity Module – Mobile Equipment (SIM – ME) interface
[8]	GSM 03.38	Digital cellular telecommunications system (Phase 2+); Alphabets and language-specific information
[9]	GSM 11.10	Digital cellular telecommunications system (Phase 2); Mobile Station (MS) conformance specification; Part 1: Conformance specification
[10]	3GPP TS 51.010-1	Digital cellular telecommunications system (Release 5); Mobile Station (MS) conformance specification
[11]	3GPP TS 34.124	Electromagnetic Compatibility (EMC) for mobile terminals and

		ancillary equipment.
[12]	3GPP TS 34.121	Electromagnetic Compatibility (EMC) for mobile terminals and ancillary equipment.
[13]	3GPP TS 34.123-1	Technical Specification Group Radio Access Network; Terminal conformance specification; Radio transmission and reception (FDD)
[14]	3GPP TS 34.123-3	User Equipment (UE) conformance specification; Part 3: Abstract Test Suites.
[15]	EN 301 908-02 V2.2.1	Electromagnetic compatibility and Radio spectrum Matters (ERM); Base Stations (BS) and User Equipment (UE) for IMT-2000. Third Generation cellular networks; Part 2: Harmonized EN for IMT-2000, CDMA Direct Spread (UTRA FDD) (UE) covering essential requirements of article 3.2 of the R&TTE Directive
[16]	EN 301 489-24 V1.2.1	Electromagnetic compatibility and Radio Spectrum Matters (ERM); Electromagnetic Compatibility (EMC) standard for radio equipment and services; Part 24: Specific conditions for IMT-2000 CDMA Direct Spread (UTRA) for Mobile and portable (UE) radio and ancillary equipment
[17]	IEC/EN60950-1(2001)	Safety of information technology equipment (2000)
[18]	3GPP TS 51.010-1	Digital cellular telecommunications system (Release 5); Mobile Station (MS) conformance specification
[19]	GCF-CC V3.23.1	Global Certification Forum - Certification Criteria
[20]	2002/95/EC	Directive of the European Parliament and of the Council of 27 January 2003 on the restriction of the use of certain hazardous substances in electrical and electronic equipment (RoHS)
[21]	Audio Application Note V1.01	Audio Application Note V1.01
[22]	PCM Application Note V1.02	PCM Application Note V1.02
[23]	Keypad Application Note V1.01	Keypad Application Note V1.01
[24]	<i>Sleep_Application_Note</i>	<i>Sleep_Application_Note</i>
[25]	<i>Waking_up_Application_Note</i>	<i>Waking_up_Application_Note</i>
[26]	Module secondary-SMT-UGD	SMT Note

E. Terms and Abbreviations

Table 49: Terms and Abbreviations

Abbreviation	Description
ADC	Analog-to-Digital Converter
ARP	Antenna Reference Point
BER	Bit Error Rate
BTS	Base Transceiver Station
CS	Coding Scheme







CSD	Circuit Switched Data
CTS	Clear to Send
DAC	Digital-to-Analog Converter
DRX	Discontinuous Reception
DSP	Digital Signal Processor
DTE	Data Terminal Equipment (typically computer, terminal, printer)
DTR	Data Terminal Ready
DTX	Discontinuous Transmission
EFR	Enhanced Full Rate
EGSM	Enhanced GSM
EMC	Electromagnetic Compatibility
ESD	Electrostatic Discharge
ETS	European Telecommunication Standard
FCC	Federal Communications Commission (U.S.)
FD	SIM fix dialing phonebook
FDMA	Frequency Division Multiple Access
FR	Full Rate
GMSK	Gaussian Minimum Shift Keying
GPRS	General Packet Radio Service
GSM	Global Standard for Mobile Communications
HR	Half Rate
I2C	Inter-Integrated Circuit
IMEI	International Mobile Equipment Identity
Inorm	Normal Current
Imax	Maximum Load Current
kbps	Kilo bits per second
Li-Ion	Lithium-Ion
MO	Mobile Originated
MS	Mobile Station (GSM engine), also referred to as TE
MT	Mobile Terminated
PAP	Password Authentication Protocol
PBCCH	Packet Switched Broadcast Control Channel
PCB	Printed Circuit Board
PCS	Personal Communication System, also referred to as GSM 1900
RF	Radio Frequency
RMS	Root Mean Square (value)
RTC	Real Time Clock
Rx	Receive Direction
SIM	Subscriber Identification Module
SMS	Short Message Service
SPI	serial peripheral interface
TDMA	Time Division Multiple Access
TE	Terminal Equipment, also referred to as DTE
TX	Transmit Direction
UART	Universal Asynchronous Receiver & Transmitter
VSWR	Voltage Standing Wave Ratio
Vmax	Maximum Voltage Value
Vnorm	Normal Voltage Value

Vmin	Minimum Voltage Value
VIHmax	Maximum Input High Level Voltage Value
VIHmin	Minimum Input High Level Voltage Value
VILmax	Maximum Input Low Level Voltage Value
VILmin	Minimum Input Low Level Voltage Value
VImax	Absolute Maximum Input Voltage Value
VImin	Absolute Minimum Input Voltage Value
VOHmax	Maximum Output High Level Voltage Value
VOHmin	Minimum Output High Level Voltage Value
VOLmax	Maximum Output Low Level Voltage Value
VOLmin	Minimum Output Low Level Voltage Value
SM	SIM phonebook
NC	Not connect
EDGE	Enhanced data rates for GSM evolution
HSDPA	High Speed Downlink Packet Access
HSUPA	High Speed Uplink Packet Access
ZIF	Zero intermediate frequency
WCDMA	Wideband Code Division Multiple Access
VCTCXO	Voltage control temperature-compensated crystal oscillator
USIM	Universal subscriber identity module
UMTS	Universal mobile telecommunications system
UART	Universal asynchronous receiver transmitter

SIMCOM CONFIDENTIAL

F. Safety Caution

Table 50: Safety caution

Marks	Requirements
	When in a hospital or other health care facility, observe the restrictions about the use of mobiles. Switch the cellular terminal or mobile off, medical equipment may be sensitive to not operate normally for RF energy interference.
	Switch off the cellular terminal or mobile before boarding an aircraft. Make sure it is switched off. The operation of wireless appliances in an aircraft is forbidden to prevent interference with communication systems. Forget to think much of these instructions may lead to the flight safety or offend against local legal action, or both.
	Do not operate the cellular terminal or mobile in the presence of flammable gases or fumes. Switch off the cellular terminal when you are near petrol stations, fuel depots, chemical plants or where blasting operations are in progress. Operation of any electrical equipment in potentially explosive atmospheres can constitute a safety hazard.
	Your cellular terminal or mobile receives and transmits radio frequency energy while switched on. RF interference can occur if it is used close to TV sets, radios, computers or other electric equipment.
	Road safety comes first! Do not use a hand-held cellular terminal or mobile when driving a vehicle, unless it is securely mounted in a holder for hands free operation. Before making a call with a hand-held terminal or mobile, park the vehicle.
	<p>GSM cellular terminals or mobiles operate over radio frequency signals and cellular networks and cannot be guaranteed to connect in all conditions, for example no mobile fee or a invalid SIM card. While you are in this condition and need emergent help, please remember using emergency calls. In order to make or receive calls, the cellular terminal or mobile must be switched on and in a service area with adequate cellular signal strength.</p> <p>Some networks do not allow for emergency call if certain network services or phone features are in use (e.g. lock functions, fixed dialing etc.). You may have to deactivate those features before you can make an emergency call.</p> <p>Also, some networks require that a valid SIM card be properly inserted in the cellular terminal or mobile.</p>

Contact us:

Shanghai SIMCom Wireless Solutions Ltd.

Add: SIM Technology Building, No.633, Jinzhong Road, Changning District, Shanghai P.R. China 200335

Tel: +86 21 3235 3300

Fax: +86 21 3235 3301

URL: www.sim.com/wm

SIMCOM CONFIDENTIAL FILE