



A company of SIM Tech

SIM5320ALD_User_Manual

SIMCOM CONFIDENTIAL FILE

Document Title	SIM5320ALD User Manual
Version	1.01
Date	2014-08-20
Status	Release
Document Control ID	SIM5320ALD_User Manual_V1.01

Compliance Information

FCC Compliance Statement: This device complies with Part 15 of the FCC Rules . Operation is subject to the following two conditions: 1. This device may not cause harmful interference, and 2. This device must accept any interference received, including interference that may cause undesired operation. This device must accept any interference received, including interference that may cause undesired operation. Product that is a radio transmitter is labeled with FCC ID.

FCC Caution

- (1) Exposure to Radio Frequency Radiation. This equipment must be installed and operated in accordance with provided instructions and the antenna(s) used for this transmitter must be installed to provide a separation distance of at least 20 cm from all persons and must not be collocated or operating in conjunction with any other antenna or transmitter. End-users and installers must be provided with antenna installation instructions and transmitter operating conditions for satisfying RF exposure compliance.
- (2) Any changes or modifications not expressly approved by the grantee of this device could void the user's authority to operate the equipment.
- (3) This Transmitter must not be co-located or operating in conjunction with any other antenna or transmitter.
- (4) Changes or modifications to this unit not expressly approved by the party responsible for compliance could void the user authority to operate the equipment.
- (5) the modules FCC ID is not visible when installed in the host, or
- (6) if the host is marketed so that end users do not have straight forward commonly used methods for access to remove the module so that the FCC ID of the module is visible; then an additional permanent label referring to the enclosed module: Contains Transmitter Module FCC ID: UDV-1403022014009 or Contains FCC ID: UDV-1403022014009 must be used.

General Notes

SIMCom offers this information as a service to its customers, to support application and engineering efforts that use the products designed by SIMCom. The information provided is based upon requirements specifically provided to SIMCom by the customers. SIMCom has not undertaken any independent search for additional relevant information, including any information that may be in the customer's possession. Furthermore, system validation of this product designed by SIMCom within a larger electronic system remains the responsibility of the customer or the customer's system integrator. All specifications supplied herein are subject to change.

Copyright

This document contains proprietary technical information which is the property of SIMCom Limited, copying of this document and giving it to others and the using or communication of the contents thereof, are forbidden without express authority. Offenders are liable to the payment of damages. All rights reserved in the event of grant of a patent or the registration of a utility model or design. All specification supplied herein are subject to change without notice at any time.

Copyright © Shanghai SIMCom Wireless Solutions Ltd. 2014

SIMCOM CONFIDENTIAL FILE

Contents

Revision History.....	10
1 Introduction.....	11
1.1 Product Outline.....	11
1.2 Hardware Interface Overview.....	11
1.3 Hardware Diagram.....	11
1.4 Functional Overview.....	12
2 Package Information.....	13
2.1 Pin Configuration.....	13
2.2 Pin description.....	17
2.3 Package Dimensions.....	19
2.4 Footprint Recommendation.....	21
3 Application Interface Specification.....	22
3.1 Power Supply.....	22
3.1.1 Power Supply Pin.....	22
3.1.2 Design Guide.....	22
3.1.3 RTC Backup.....	24
3.2 Power on/off Time Sequence.....	26
3.2.1 Power on Sequence.....	26
3.2.2 Power off Sequence.....	28
3.3 UART Interface.....	29
3.3.1 Pin Description.....	30
3.3.2 Application Guide.....	31
3.4 Audio Interfaces (For SIM5320ALD only).....	32
3.4.1 Pin Description.....	32
3.4.2 Design Guide.....	32
3.4.3 Audio Parameter Characteristic.....	34
3.5 USIM Interface.....	35
3.5.1 Pin description.....	35
3.5.2 Application Guide.....	36
3.5.3 Recommend Components.....	36
3.6 I2C Interface.....	37
3.6.1 Pin Description.....	38
3.6.2 Signal Description.....	38
3.6.3 Design Guide.....	38
3.7 Keypad Interface.....	38
3.7.1 Pin Description.....	38
3.7.2 Application Guide.....	39
3.8 USB Interface.....	40
3.8.1 Application Guide.....	40
3.9 SPI Interface.....	41
3.9.1 Pin Description.....	41

3.10 GPIO Interface.....	41
3.10.1 Pin Description.....	41
3.10.2 Application Guide.....	42
3.11 PCM Interface.....	44
3.11.1 Pin Description.....	44
3.11.2 Signal Description.....	45
3.12 Multi-functional interface.....	48
3.12.1 Sink Current Source.....	48
3.12.2 Reset Function.....	49
3.12.3 ADC.....	49
3.12.4 LDO.....	50
4 RF Specification.....	50
4.1 RF Specification.....	50
4.2 Operating Specification.....	51
4.3 Antenna Design Guide.....	51
5 Reliability and Operating Characteristics.....	53
5.1 Electronic Characteristics.....	53
5.2 Operating Mode.....	53
5.2.1 Operating Modes Overview.....	54
5.2.2 Minimize Power Consumption.....	54
5.3 Current Consumption.....	55
5.4 EMC and ESD Notes.....	56
6 Guide for Production.....	57
6.1 Top and Bottom View of SIM5320ALD.....	57
6.2 Typical Solder Reflow Profile.....	57
6.3 Moisture Sensitivity Level (MSL).....	58
6.4 Stencil Foil Design Recommendation.....	58
6.5 Recommended Pad Design.....	59
Appendix.....	60
A. System Design.....	60
B. SIM5320ALD GPIOs List.....	61
C. Digital I/O Characteristics.....	61
D. Related Documents.....	62
E. Terms and Abbreviations.....	63
F. Safety Caution.....	66

Table Index

Table 1: General Feature.....	10
Table 2: Pin definition.....	14
Table 3: Pin description.....	15
Table 4: Pin description.....	20
Table 5: Power on timing.....	25
Table 6: Power off timing.....	26
Table 7: Pin description.....	28
Table 8: Logic level.....	28
Table 9: Pin description.....	30
Table 10: MIC input characteristics.....	30
Table 11: Audio output characteristics.....	30
Table 12: Speaker output characteristics.....	30
Table 13: Audio parameter.....	32
Table 14: Electronic characteristic.....	33
Table 15: Pin description.....	33
Table 17: Pin description.....	36
Table 18: Pin description.....	36
Table 19: GPIO configuration.....	37
Table 20: Electronic characteristic.....	38
Table 21: Electronic characteristic.....	39
Table 22: Pin description.....	39
Table 23: Electronic characteristic.....	40
Table 24: Pin description.....	40
Table 25: LED status.....	41
Table 26: Control status.....	42
Table 27: Electronic characteristic.....	42
Table 28: Pin description.....	43
Table 29: Timing parameters.....	44
Table 30: Timing parameters.....	45
Table 31: Electronic characteristic.....	46
Table 32: Electronic Characteristics.....	48
Table 33: Electronic characteristic.....	48
Table 34: Conducted transmission power.....	49
Table 35: Operating frequencies.....	49
Table 36: Conducted receive sensitivity.....	49
Table 37: HSDPA throughout.....	49
Table 38: Absolute maximum ratings.....	51
Table 39: Recommended operating ratings.....	51
Table 40: Operating temperature.....	51
Table 41: Operating Modes Overview.....	52
Table 42: Current consumption.....	53
Table 43: The ESD performance measurement table (Temperature: 25°C, Humidity: 45%).....	54

Table 43: SIM5320ALD GPIOs list.....	58
Table 44: Digital I/O characteristics.....	58
Table 45: Related documents.....	59
Table 46: Terms and Abbreviations.....	60
Table 47: Safety caution.....	63

SIMCOM CONFIDENTIAL FILE

Figure Index

Figure 1: SIM5320ALD functional architecture.....	11
Figure 2: Pin view.....	14
Figure 3: Top dimensions (Unit: mm).....	19
Figure 4: Side dimensions (Unit: mm).....	19
Figure 5: Bottom dimensions (Unit: mm).....	20
Figure 6: Footprint recommendation (Unit: mm).....	20
Figure 8: VBAT input application circuit.....	22
Figure 9: Reference circuit of the LDO power supply.....	22
Figure 10: Reference circuit of the DCDC power supply.....	23
Figure 11: RTC supply from capacitor.....	24
Figure 12: RTC supply from non-chargeable battery.....	24
Figure 13: RTC supply from rechargeable battery.....	24
Figure 14: Seiko XH414H-IV01E Charge-Discharge characteristic.....	25
Figure 15: Power on Timing Sequence.....	26
Figure 16: Power off timing sequence.....	27
Figure 17: Full modem.....	28
Figure 18: Null modem.....	29
Figure 19: RI behaviour in NULL Modem.....	30
Figure 20: RI behaviour in FULL Modem.....	30
Figure 21: Speaker interface configuration.....	32
Figure 22: Receiver interface configuration.....	32
Figure 23: Microphone interface configuration.....	33
Figure 24: USIM interface reference circuit.....	35
Figure 25: Amphenol SIM card socket.....	36
Figure 26: Reference circuit.....	38
Figure 27: USB interface.....	39
Figure 28: Application circuit.....	42
Figure 29: Flight mode switch.....	43
Figure 30: Synchrony timing.....	44
Figure 31: EXT CODEC to MODULE timing.....	45
Figure 32: MODULE to EXT CODEC timing.....	45
Figure 33: Synchrony timing.....	46
Figure 34: EXT CODEC to MODULE timing.....	46
Figure 35: MODULE to EXT CODEC timing.....	46
Figure 36: Current drive.....	48
Figure 37: Reset circuit.....	48
Figure 38: Reference circuit.....	49
Figure 39: Antenna matching circuit.....	51
Figure 40: Top and bottom view of SIM5320ALD.....	56
Figure 41: The ramp-soak-spike reflow profile of SIM5320ALD.....	56
Figure 42: Recommended pad.....	57
Figure 43: System design.....	58

SIMCOM CONFIDENTIAL FILE

Revision History

Data	Version	Description of change	Author
2014-08-20	1.01	Original	Libing

SIMCOM CONFIDENTIAL

1 Introduction

This document describes electronic specifications, RF specifications, function interface, mechanical characteristic and testing conclusions of the SIMCom SIM5320ALD module. With the help of this document and other SIM5320ALD software application notes, user guides, users can quickly understand and use SIM5320ALD module to design and develop applications quickly.

1.1 Product Outline

Designed for global market, SIM5320ALD is a dual-band UMTS /HSDPA that works on frequencies of WCDMA 1900/850MHz. The SIM5320ALD support HSDPA.

With a tiny configuration of 30*30*2.9 mm and integrated functions, SIM5320ALD can meet almost any space requirement in users' application, such as Smart phone, PDA phone, industrial handhelds, machine-to-machine, vehicle applications, etc..

There are 80 pins on SIM5320ALD, which provide most application interfaces for customers' board.

1.2 Hardware Interface Overview

Sub-interfaces are described in detail in the next chapter, which includes:

- Power Supply
- USB Interface
- Serial Interface
- Analog Audio Interfaces (SIM5320ALD only)
- SIM Interface
- GPIO
- ADC
- LDO Power Output
- Sink Current Source
- Keypad Interface
- SPI Interface
- RTC
- I2C Interface

1.3 Hardware Diagram

The global architecture of the SIM5320ALD Embedded module is described in the figure below.

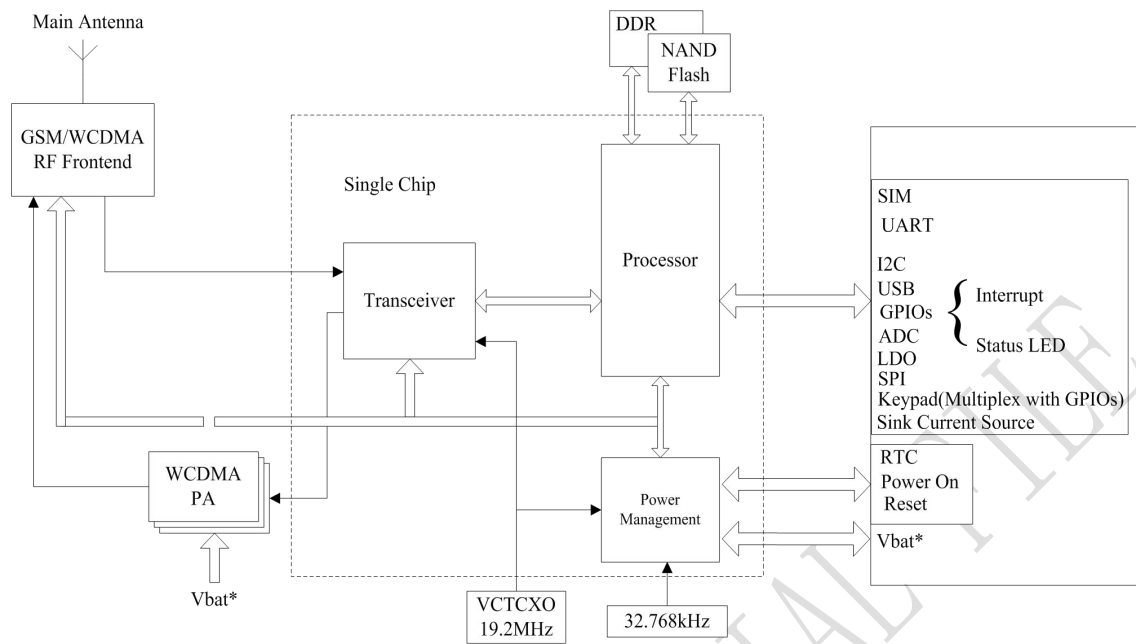

Figure 1: SIM5320ALD functional architecture

1.4 Functional Overview

Table 1: General Feature

Feature	Implementation
Power supply	Single supply voltage 3.3~4.2V
Transmission data	<ul style="list-style-type: none"> ● Dual-mode UMTS/HSDPA operation ● UMTS R99 data rates-384 kbps DL/UL ● HSDPA Category 5/6 -3.6 Mbps Category12-1.8 Mbps ● CSD feature: 9.6, 14.4, 64 kbps UL/DL
Audio features (SIM5320ALD only)	Speech codec modes: <ul style="list-style-type: none"> ● Half Rate (ETS 06.20) ● Full Rate (ETS 06.10) ● Enhanced Full Rate (ETS 06.50 / 06.60 / 06.80) ● AMR (WCDMA) ● A5/1, A5/2, and A5/3 ciphering
SMS	<ul style="list-style-type: none"> ● MT, MO, CB, Text and PDU mode ● SMS storage: SIM card ● Support transmission of SMS alternatively over CSD. User can choose preferred mode.
SIM interface	Support identity card: 1.8V, 3V.
Serial interface	<ul style="list-style-type: none"> ● Serial Port standard or null modem mode on Serial Port Interface ● Serial Port can be used to control module by sending AT command

USB	Support USB2.0 Slave mode
Phonebook management	Support phonebook types: SM, FD, LD, RC, ON, MC.
SIM application toolkit	Support SAT class 3, GSM 11.14 Release 98 Support USAT
Real Time Clock	Support RTC
Timer function	Programmable by AT command
Physical characteristics	Size:30*30*2.9mm Weight:5.6g
PCM (SIM5320ALD only)	Multiplex on GPIOs. 3 kinds of coding formats: 8 bit (u-law or A-law) and 16 bit (linear).
Firmware upgrade	Firmware upgrade over USB interface
Temperature range	<ul style="list-style-type: none"> ● Operation temperature: -30°C to +80°C ● Storage temperature -40°C to +85°C

2 Package Information

2.1 Pin Configuration

All hardware interfaces which connect SIM5320ALD to customers' application platform are through 80 pins pads (Metal half hole). Figure 2 is SIM5320ALD outline diagram.

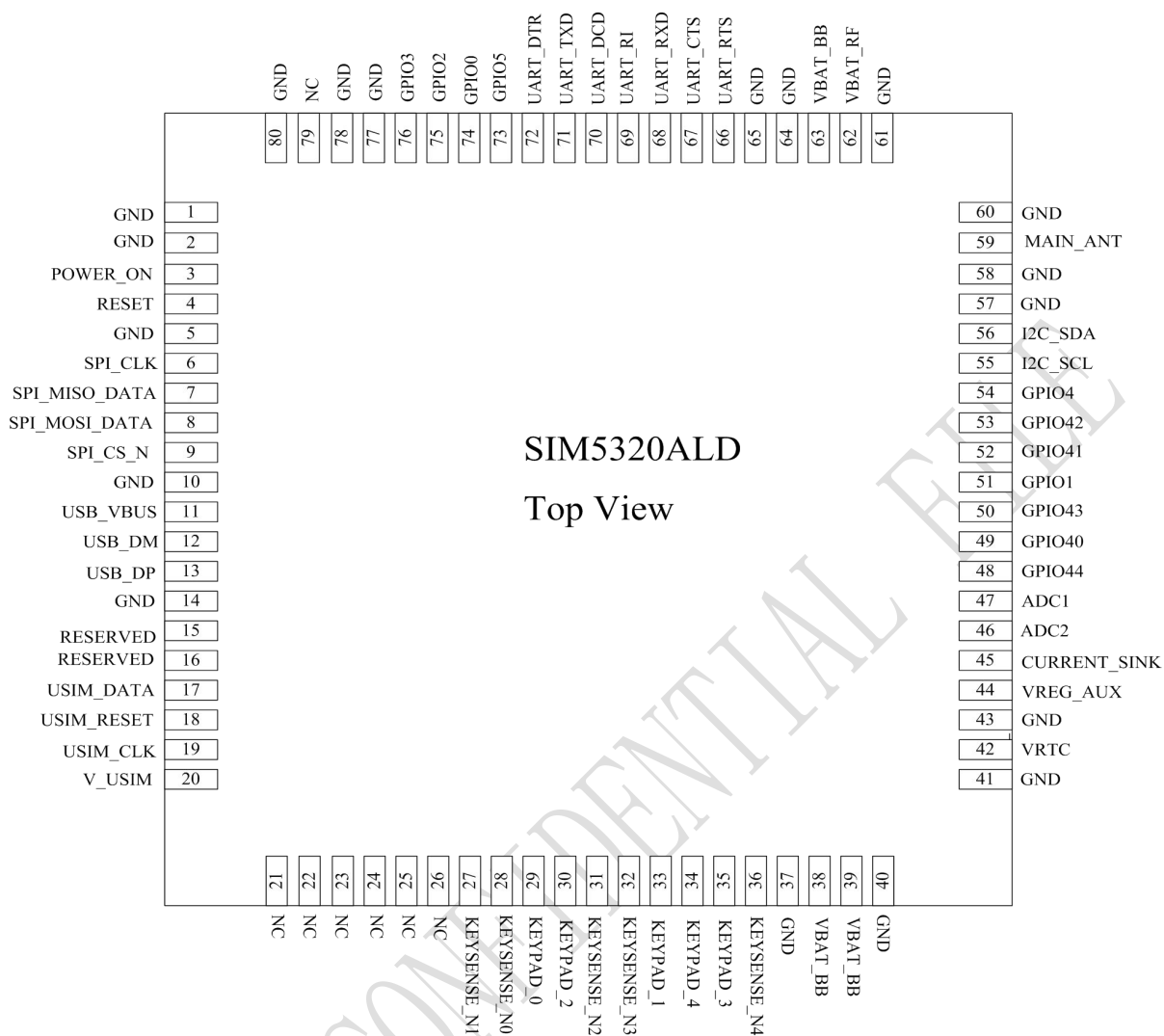

Figure 2: Pin view

Table 2: Pin definition

Pin No.	Define	Pin No.	Define
1	GND	2	GND
3	POWER_ON	4	RESET
5	GND	6	SPI_CLK
7	SPI_MISO_DATA	8	SPI_MOSI_DATA
9	SPI_CS_N	10	GND
11	USB_VBUS	12	USB_DM
13	USB_DP	14	GND
15	RESERVED	16	RESERVED
17	USIM_DATA	18	USIM_RESET
19	USIM_CLK	20	V_USIM
21	NC	22	NC
23	NC	24	NC
25	NC	26	NC
27	KEYSENSE_N1	28	KEYSENSE_N0
29	KEYPAD_0	30	KEYPAD_2
31	KEYSENSE_N2	32	KEYSENSE_N3
33	KEYPAD_1	34	KEYPAD_4
35	KEYPAD_3	36	KEYSENSE_N4
37	GND	38	VBAT_BB
39	VBAT_BB	40	GND
41	GND	42	VRTC
43	GND	44	VREG_AUX
45	CURRENT_SINK	46	ADC2
47	ADC1	48	GPIO44
49	GPIO40	50	GPIO43
51	GPIO1	52	GPIO41
53	GPIO42	54	GPIO4
55	I2C_SCL	56	I2C_SDA
57	GND	58	GND
59	MAIN_ANT	60	GND
61	GND	62	VBAT_RF
63	VBAT_RF	64	GND
65	GND	66	UART_RTS

67	UART_CTS	68	UART_RXD
69	UART_RI	70	UART_DCD
71	UART_TXD	72	UART_DTR
73	NC	74	NC
75	NC	76	NC
77	GND	78	GND
79	GPS_ANT	80	GND

2.2 Pin description

Table 3: Pin description

Pin name	I/O	Description	Comment
Power Supply			
VBAT_RF/VBAT_BB		Power supply voltage	
VRTC	I/O	Power supply for RTC	If it is unused, keep open.
VREG_AUX	O	LDO power output	
GND		Ground	
Power on/off			
POWER_ON	I	POWER_ON should be pulled low at least 64ms to power on or 500ms to power off the module.	
Audio interface			
MIC1P	I	Differential audio input	If it is unused, connect to ground through a 100N capacitor.
MIC1N			
EAR1P	O	Differential audio output	If these pins are unused, keep open.
EAR1N			
SPK_P	O		
SPK_N			
USIM interface			
V_USIM	O	Voltage Supply for SIM card Support 1.8V or 3V SIM card	All signals of SIM interface should be protected against ESD/EMC.
USIM_DATA	I/O	SIM Data Output/Input	
USIM_CLK	O	SIM Clock	
USIM_RESET	O	SIM Reset	
SPI interface			
SPI_CLK	O	SPI clock	If it is unused, keep open.
SPI_CS_N	O	SPI chip-select	

SPI_MOSI_DATA	O	SPI (master only) master out/slave in data	
SPI_MISO_DATA	I	SPI (master only) master in/slave out data	
USB			
USB_VBUS	I	USB power supply input	
USB_DP	I/O	Plus (+) line of the differential, bi-directional USB signal to/from the peripheral device.	They are compliant with the USB 2.0 specification. If it is unused, keep open.
USB_DM	I/O	Minus (-) line of the differential, bi-directional USB signal to/from the peripheral device.	
Serial interface			
UART_RXD	I	Receive Data	UART_RXD has been pulled down with a 12kR resistor to ground in the module. If it is unused, keep open.
UART_TXD	O	Transmit Data	
UART_RTS	O	Request to send	
UART_CTS	I	Clear to Send	
UART_RI	O	Ring Indicator	
UART_DTR	I/O	DTE get ready	
UART_DCD	O	Carrier detects	
I2C interface			
I2C_SDA	I/O	I2C data	Pulled up with a 2.2kR resistor to 2.6V internally. If it is unused, keep open.
I2C_SCL	O	I2C clock output	
Keypad interface			
KEYPAD_0	O	Bit 0 drive to the pad matrix	All Keypad pins can be configured as GPIOs. If it is unused, keep open.
KEYPAD_1	O	Bit 1 drive to the pad matrix	
KEYPAD_2	O	Bit 2 drive to the pad matrix	
KEYPAD_3	O	Bit 3 drive to the pad matrix	
KEYPAD_4	O	Bit 4 drive to the pad matrix	
KEYSENSE_N0	I	Bit 0 for sensing key press on pad matrix	
KEYSENSE_N1	I	Bit 1 for sensing key press on pad matrix	
KEYSENSE_N2	I	Bit 2 for sensing key press on pad matrix	
KEYSENSE_N3	I	Bit 3 for sensing key press on pad matrix	
KEYSENSE_N4	I	Bit 4 for sensing key press on pad matrix	
PCM interface			
PCM_DIN/GPIO0	I	General Input PIN with module wake/interrupt. It also can be multiplexed as the PCM_DIN pin.	If it is unused, keep open.

PCM_SYNC/GPIO2	I	General Input PIN. It also can be multiplexed as the PCM_SYNC pin.	
PCM_CLK/GPIO3	O	General Output PIN. It also can be multiplexed as the PCM_CLK pin.	
PCM_DOUT/GPIO5	O	General Output PIN. It also can be multiplexed as the PCM_DOUT pin.	
GPIOs			
GPIO1	O	Output PIN as LED control for network status.	If it is unused, keep open.
GPIO4	I	Input PIN as RF operating control.	
GPIO40	O	Output PIN as operating status indicating of module.	
GPIO41	I/O	General input/output PIN. It can be used as wake/interrupt signal to host from module	
GPIO43	I/O	General input/output PIN. It can be used as wake/interrupt signal to module from host.	
GPIO44	I/O	General input/output PIN.	
GPIO42	I/O	General input/output PIN.	
Other interface			
RESET	I	System reset in, active low.	
CURRENT_SINK	I	Current source of ground-referenced current sink	Refer to 3.13.1
ADC1	I	Analog Digital Converter Input	Refer to 3.13.3
ADC2	I	Battery temperature ADC input pin	
MAIN_ANT	I/O	ANT soldering pad	

2.3 Package Dimensions

The following figure shows mechanical dimensions of SIM5320ALD.

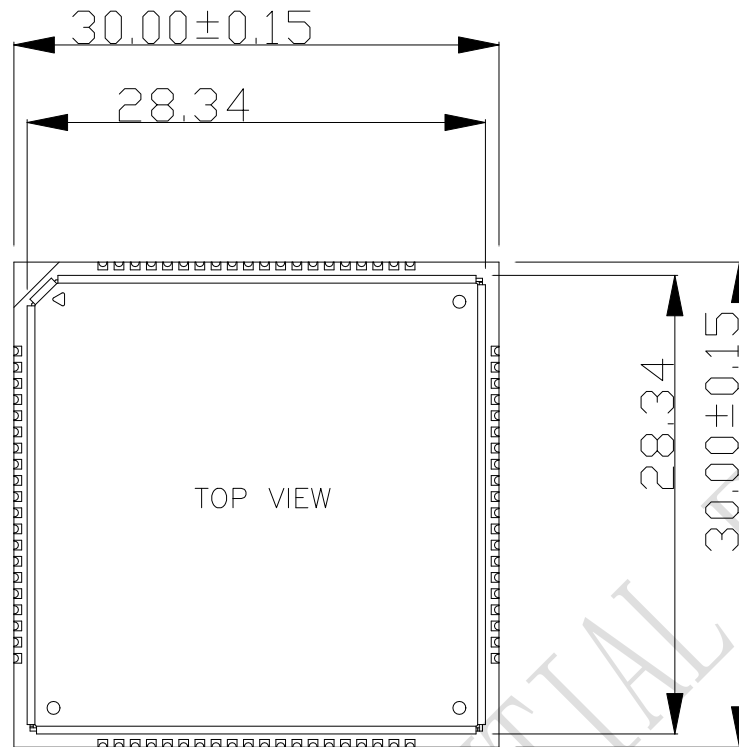

Figure 3: Top dimensions (Unit: mm)

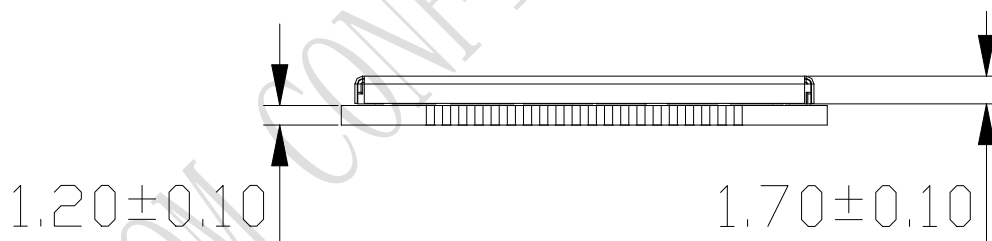

Figure 4: Side dimensions (Unit: mm)

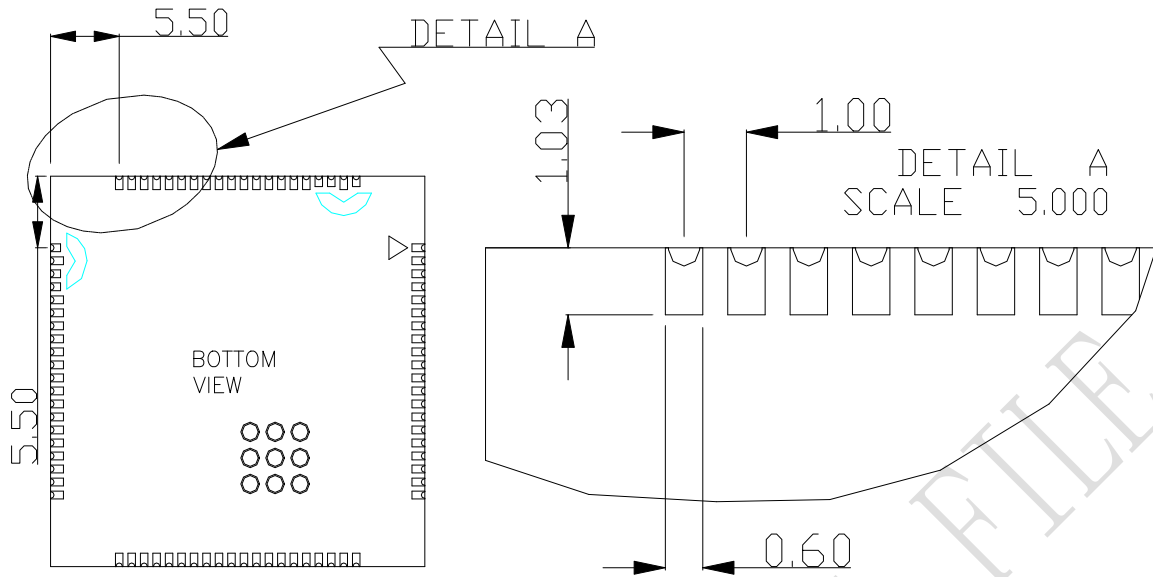
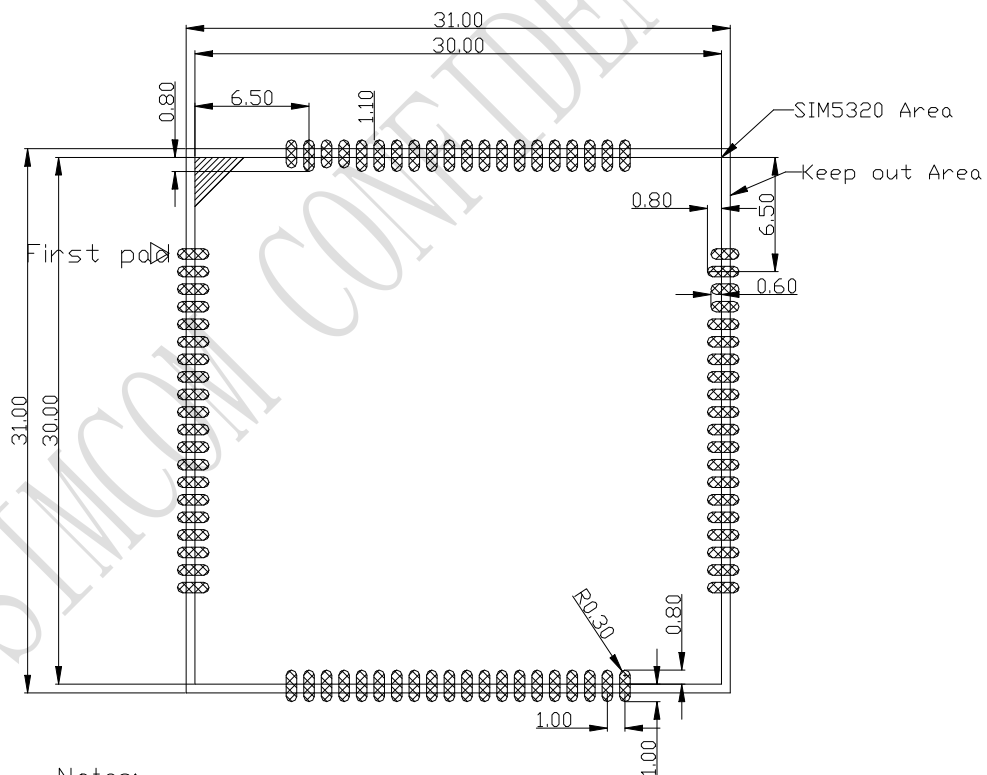

Figure 5: Bottom dimensions (Unit: mm)

2.4 Footprint Recommendation



Notes:
Silk screen and copper exposure are not allowed in the Keep out Area.

Figure 6: Footprint recommendation (Unit: mm)

3 Application Interface Specification

3.1 Power Supply

The power supply pins of SIM5320ALD include VBAT_RF and VBAT_BB. VBAT_RF directly supplies the power to RF PA; VBAT_BB supplies the power to the baseband system. For the VBAT_RF, the current consumption rises typically to peak of more than 2A. So the power supply must be able to provide sufficient current up to more than 2A. The following figure is the VBAT_RF voltage ripple wave at the maximum power transmit phase.

Please refer to [Figure 8](#)—Application circuit VBAT_RF=4.0V, VBAT maximum output current =2A, C_A=100 μF tantalum capacitor (ESR=0.7Ω) and C_B=1 μF.

3.1.1 Power Supply Pin

Two VBAT_RF and two VBAT_BB pins are dedicated to connect the supply voltage.

Table 4: Pin description

Pin type	Pin name	Min	Typ	Max	Unit
POWER	VBAT_RF	3.3	3.8	4.2	V
	VBAT_BB	3.3	3.8	4.2	V

Note: 1. Though the VBAT_RF and VBAT_BB are supplied by the same voltage level, they are different pins. VBAT_RF is for RF section and VBAT_BB is for baseband system.

2. When the module is power off, users must pay attention to the issue about current leakage. Refer to Chapter 3.10.2 Note2.

3.1.2 Design Guide

Mostly, user connects the VBAT_RF and VBAT_BB pins with one power supply. Make sure that the input voltage at the VBAT_BB pin will never drop below 3.3V even during a transmit burst when the current consumption rises up to more than 2A. If the power voltage drops below 3.3V, the module may be shut down automatically. Using a large tantalum capacitor (above 100uF) will be the best way to reduce the voltage drops. If the power current cannot support up to 2A, users must introduce larger capacitor (typical 1000uF) to storage electric power.

For the consideration of RF performance and system stability, another large capacitor (above 100uF) should be located at the VBAT_RF pin and some multi-layer ceramic chip (MLCC) capacitors (0.1uF) need to be used for EMC because of their low ESR in high frequencies. Note that capacitors should be put

beside VBAT_RF pins as close as possible. Also User should minimize the PCB trace impedance from the power supply to the VBAT pins through widening the trace to 80 mil or more on the board. The following figure is the recommended circuit.

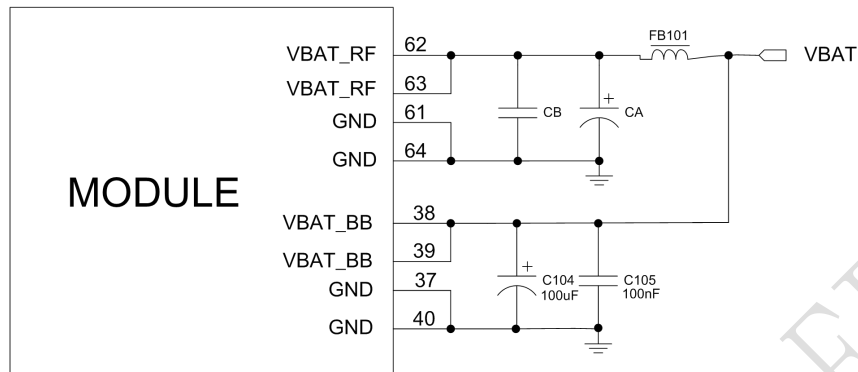

Figure 8: VBAT input application circuit

There are three sections about how to design and optimize users' power systems.

Power supply circuit

We recommend DCDC or LDO is used for the power supply of the module, make sure that the peak current of power components can rise up to more than 2A. The following figure is the reference design of +5V input power supply. The designed output for the power supply is 4.1V, here a linear regulator can be used.

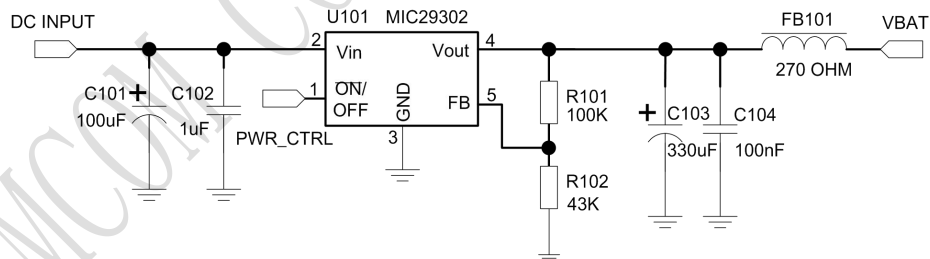

Figure 9: Reference circuit of the LDO power supply

If there is a big difference between the input voltage and the desired output (VBAT), a switching converter power will be preferable because of its better efficiency, especially at the high current situation. The following figure is the reference circuit. Note that DCDC may deprave RF performance because of ripple current intrinsically.

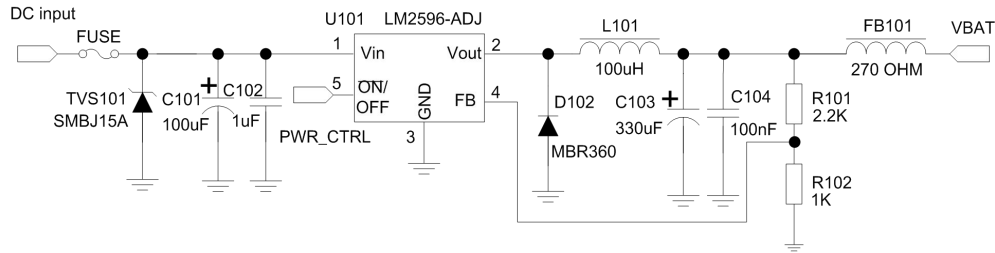

Figure 10: Reference circuit of the DCDC power supply

Voltage monitor

To monitor the power supply voltage, user can use the AT command “AT+CBC”, this command has two parameters: the battery status and the voltage value (mV). It will return the capacity percentage and actual value of battery (at the VBAT_BB pin). The voltage is continuously measured at intervals, whenever the measured battery voltage is lower than a specific value set by the AT command “AT+CVALARM”. For example, if the voltage value is set to be 3.4V, the following URC will be presented: “warning! voltage is low: 3.3v”.

If the voltage is lower than a specific value which is set by the AT command “AT+CPMVT”, the module will be powered off automatically and AT commands cannot be executed any more.

Note: Under-voltage warning function is disabled by default, user can enable it by the AT command “AT+CVALARM”. Auto power off feature is disabled by default, user should set it by the AT command “AT+CPMVT” to an appropriate value. Please refer to Document [1].

3.1.3 RTC Backup

The module uses RTC (Real Time Clock) to update and maintain inherent time and keeps system alive at no power supply status. The RTC power supply of module can be provided by an external capacitor or a battery (non-chargeable or rechargeable) through the VRTC. The following figures show various reference circuits for RTC back up. The discharge current is less than 10uA. If this feature is used, please refer to the AT commands “AT+CTZU” and “AT+CTZR”.

- **External capacitor backup**

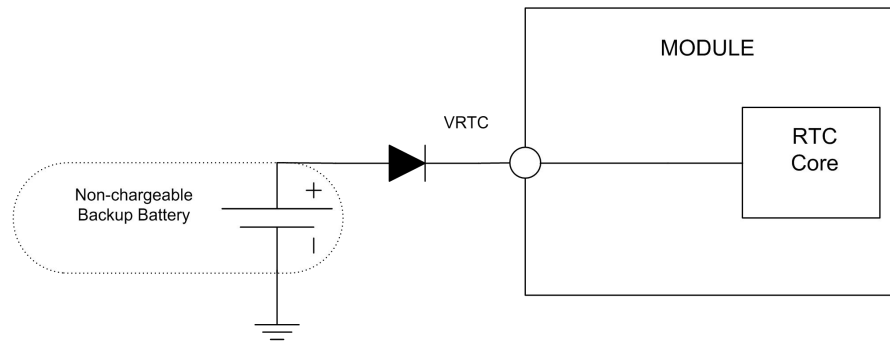

Figure 11: RTC supply from capacitor

- Non-chargeable battery backup

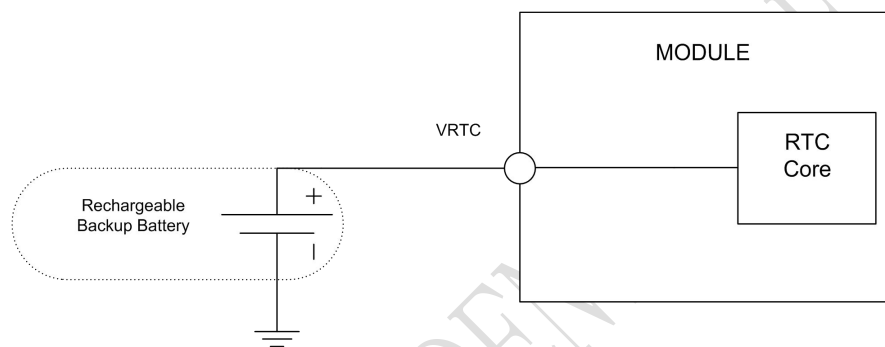

Figure 12: RTC supply from non-chargeable battery

- Rechargeable battery backup

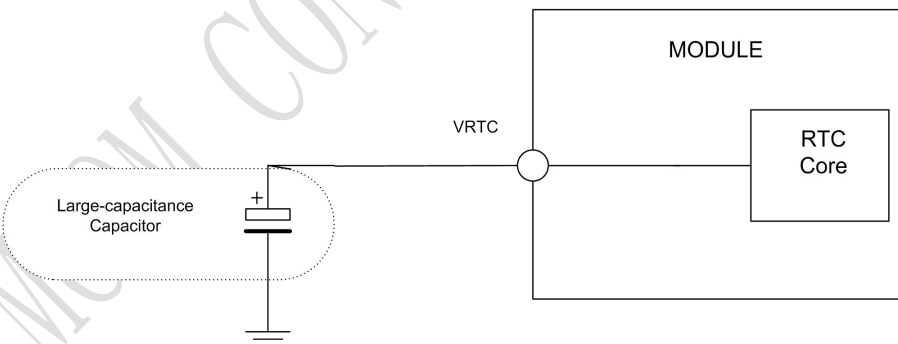

Figure 13: RTC supply from rechargeable battery

Note: The VRTC can be disabled, just disconnect it in application circuit.

Coin-type rechargeable battery is recommended, such as XH414H-IV01E from Seiko can be used. Typical charge-discharge curves for this battery are shown in the following figure.

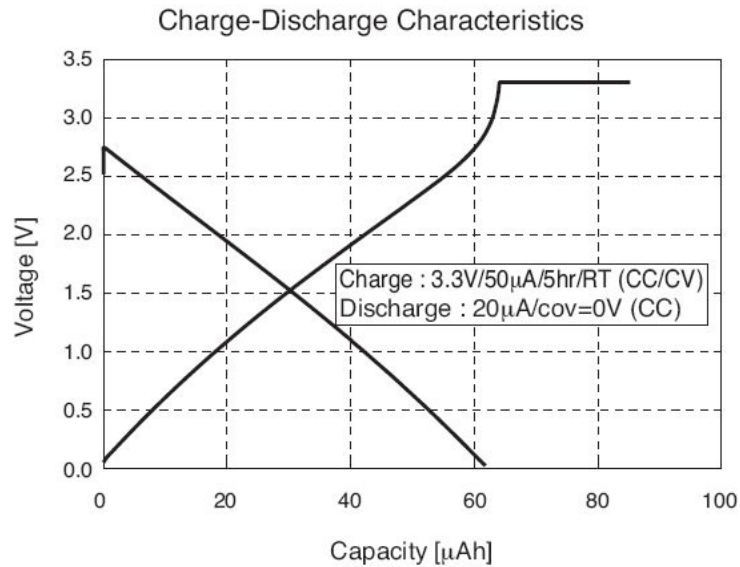

Figure 14: Seiko XH414H-IV01E Charge-Discharge characteristic

3.2 Power on/off Time Sequence

3.2.1 Power on Sequence

SIM5320ALD can be powered on by POWER_ON pin, which starts normal operating mode.

POWER_ON pin is pulled up with a 200kR resistor to 1.8V in module. User can power on the SIM5320ALD by pulling the POWER_ON pin down for a short time. The power-on scenarios are illustrated in the following figures.

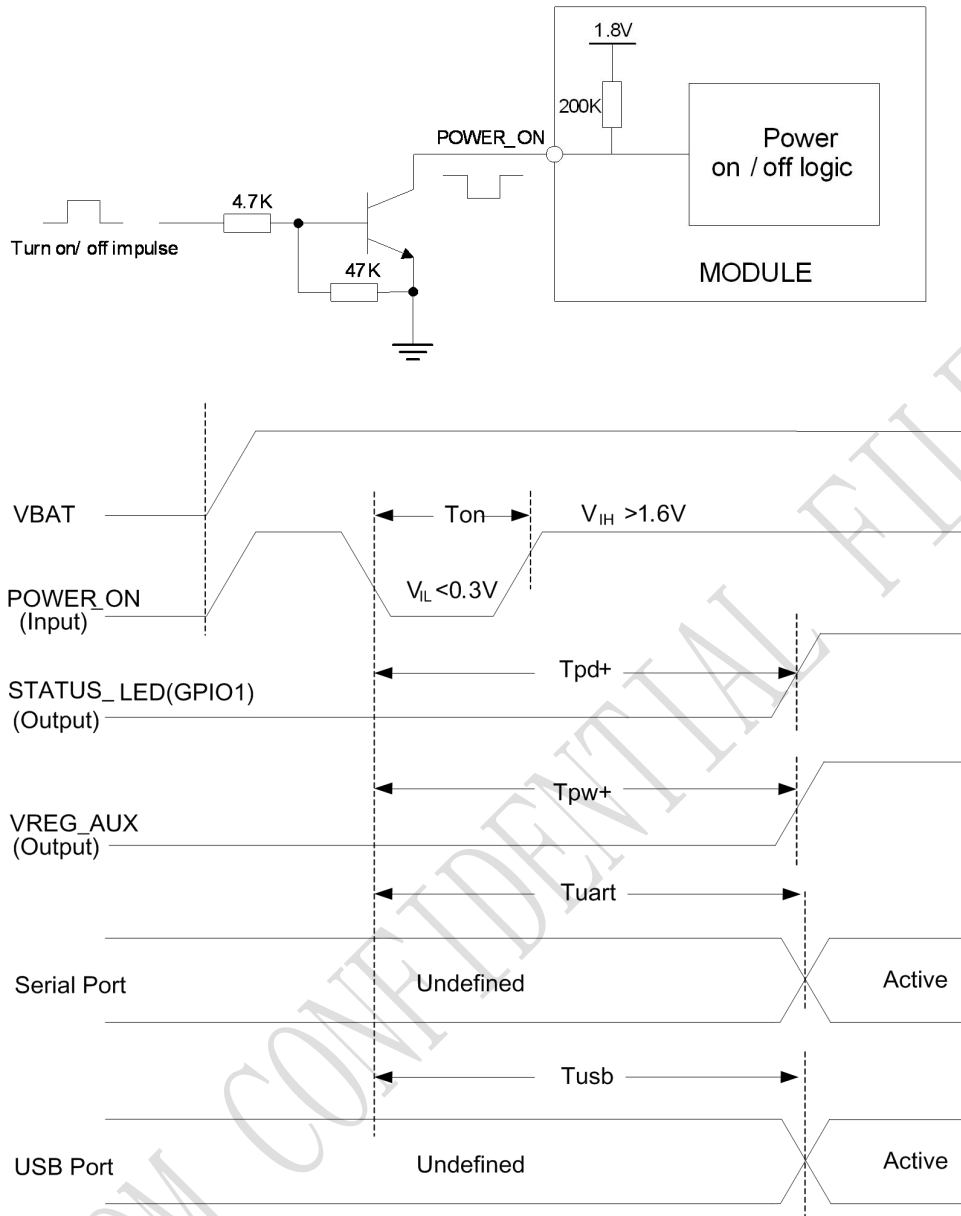

Figure 15: Power on Timing Sequence

Table 5: Power on timing

Parameter	Description	Time value			Unit
		Min.	Typ.	Max.	
Ton	The time to pull POWER_ON down to power on	64	180	-	ms
TpD+	The time to indicate connecting with the network	-	-	5.5	s
Tpw+	The time to indicate the module is powered on completely	-	-	4.5	s
Tuart	The time to enable UART	-	-	5	s

Tusb	The time to enable USB	-	-	9	s
------	------------------------	---	---	---	---

Note: Module could be automatically power on by connecting Power ON pin to Low level directly. Before designing, please refer to Document [25] for more detail.

3.2.2 Power off Sequence

The following methods can be used to power down SIM5320ALD. These procedures will make module disconnect from the network and allow the software to enter a safe state, and then save data before completely powering the module off.

- Method 1: Power off SIM5320ALD by pulling the POWER_ON pin down
- Method 2: Power off SIM5320ALD by AT command

User can power off the SIM5320ALD by pulling POWER_ON down for a specific time. The power off scenario is illustrated in the following figure.

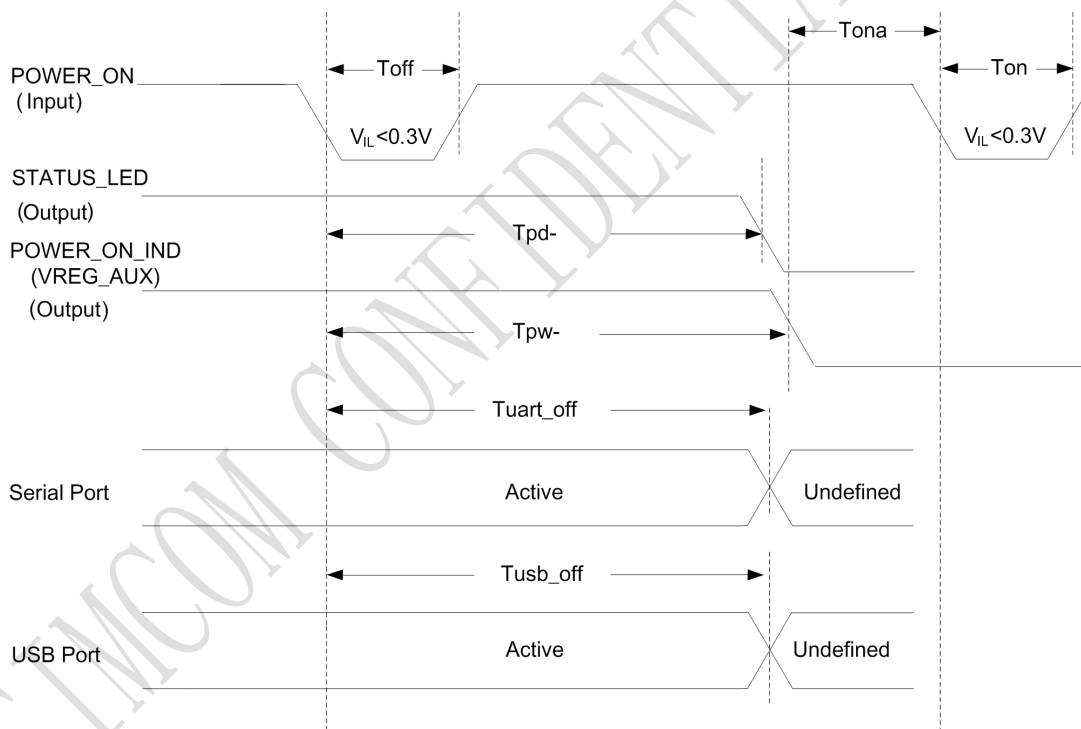

Figure 16: Power off timing sequence

Table 6: Power off timing

Parameter	Description	Time value			Unit
		Min.	Typ.	Max.	
Toff	The time pulling POWER_ON down to power off	0.5	-	5	s

TpD-	The time to indicate disconnecting from the network	-	-	7	s
Tpw-	The time to indicate the module power off completely	-	-	7.5	s
Tuart_off	The time to disable UART	-	-	6	s
Tusb_off	The time to disable USB	-	-	7.5	s
Tona	The time to power on again after Tpw-	0	-	-	s

User can also use the AT command “AT+CPOF” to power down the module. After that, the AT commands cannot be executed any longer. The module enters the POWER DOWN mode, only the RTC is still active. For details, refer to *Document [1]*.

3.3 UART Interface

SIM5320ALD provides a UART (universal asynchronous serial transmission) port. It consists of a flexible 7-wire serial interface. The module is as the DCE (Data Communication Equipment) and the client PC is as the DTE (Data Terminal Equipment). AT commands are entered and serial communication is performed through UART interface.

In order to prevent the UART signals of the module damaged due to voltage spikes or ESD, some resistors can be added on UART signals. The values of resistors are adjusted according to the actual circuit. The resistors should be placed close to the module.

The application circuit is in the following figures.

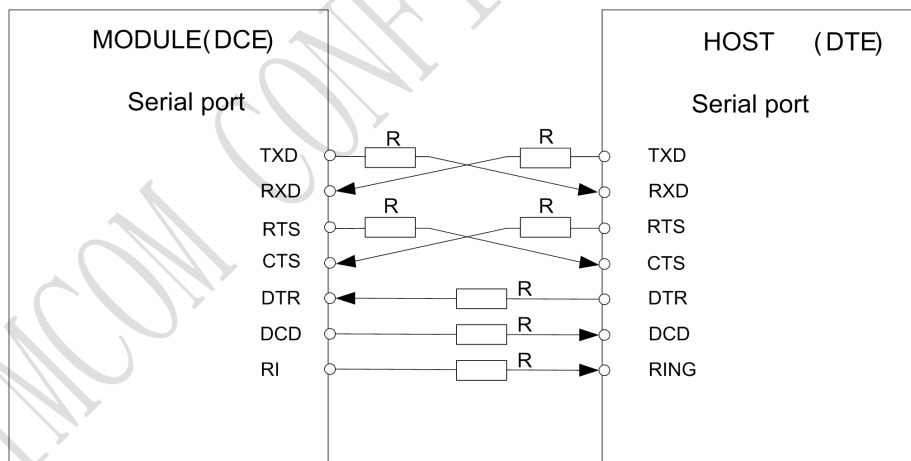

Figure 17: Full modem

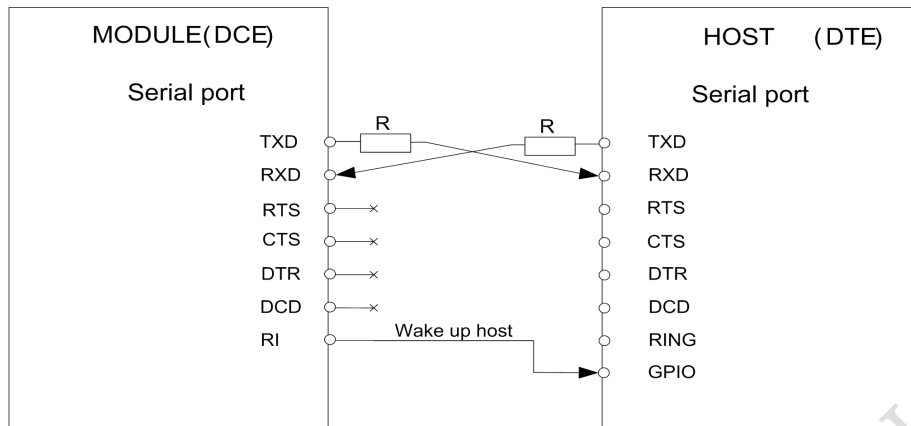

Figure 18: Null modem

3.3.1 Pin Description

Table 7: Pin description

Pin type	Pin name	Pin No.	I/O	Active voltage	Default Status
UART	UART_RXD	68	I	H	Pull-Down
	UART_TXD	71	O	H	Pull-Up
	UART_RTS	66	O	H	
	UART_CTS	67	I	H	Pull-Up
	UART_DTR	72	I	H	Pull-Up
	UART_DCD	70	O	H	
	UART_RI	69	O	H	

More pin information refers to chapter 2.2.

Table 8: Logic level

Parameter	Min	Max	Unit
Logic low input	0	0.3*VDD_EXT	V
Logic high input	0.7 *VDD_EXT	VDD_EXT +0.3	V
Logic low output	GND	0.2	V
Logic high output	VDD_EXT -0.2	VDD_EXT	V

Note: VDD_EXT (=2.6V) is e reference voltage in module internal interface.

All pins of all serial ports have 8mA driver capacity.

3.3.2 Application Guide

If UART port is used in Null Modem, the pin “RI” can be used as an interrupt signal to HOST. Normally it will keep high logic level until certain condition such as receiving SMS, voice call (CSD, video) or URC reporting, then “RI” will change to low logic level to inform the master (client PC). It will stay low until the master clears the interrupt event with AT command.

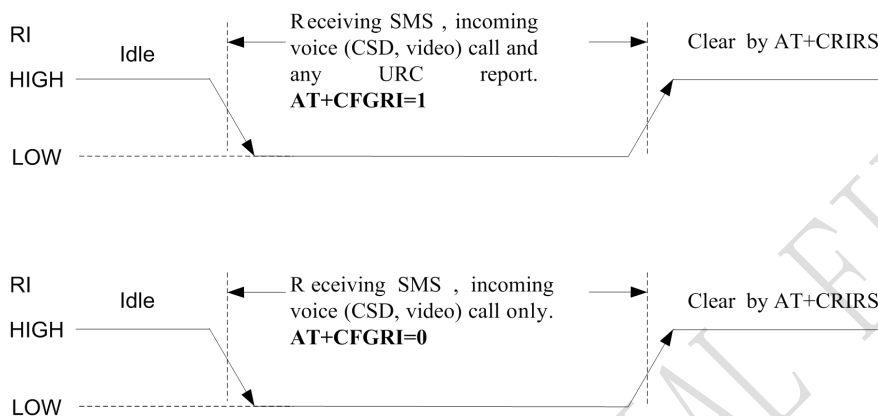

Figure 19: RI behaviour in NULL Modem

If Full Modem is used to establish communication between devices, the pin “RI” is another operation status. Initially it keeps high, when a voice call or CSD call comes, the pin “RI” will change to low for about 5900ms, then it will return to high level for 100ms. It will repeat this procedure until this call is answered or hung up.

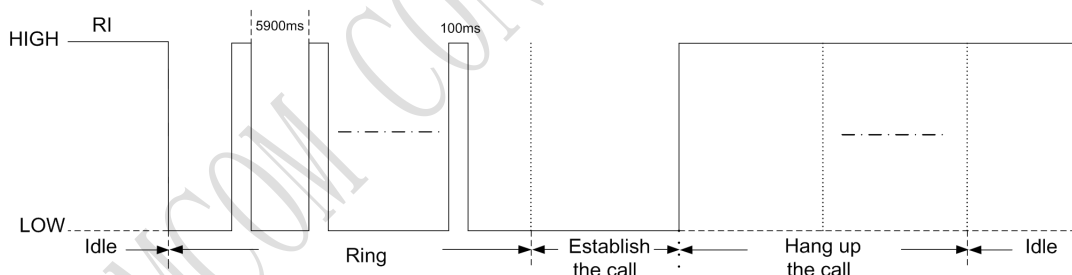

Figure 20: RI behaviour in FULL Modem

To comply with RS-232 protocol, the RS-232 level shifter chip should be used to connect SIM5320ALD to the RS-232-C interface. In this connection, the TTL level and RS-232 level are converted mutually. SIMCom recommends that user uses the SP3238ECA chip with a full modem. For more information please refers to the RS-232 chip datasheet.

Note: SIM5320ALD supports the communication rate: 300, 600, 1200, 2400, 4800, 9600, 19200, 38400, 57600, 115200, 230400, 460800, 921600, 3200000, 3686400, 4000000bps. Default rate is 115200bps.

3.4 USIM Interface

The USIM provides the required subscription verification information to allow the mobile equipment to attach to a UMTS network. Both 1.8V and 3.0V SIM Cards are supported.

3.4.1 Pin description

Table 14: Electronic characteristic

Pin name	3.0V mode			1.8V mode		
	Min	Typ	Max	Min	Typ	Max
V_USIM	2.7	3.00	3.3	1.65	1.8	2.0
USIM_RESET	0.8* V_USIM	3.00	V_USIM	0.8* V_USIM	1.8	V_USIM
USIM_CLK	0.7* V_USIM	3.00	V_USIM	0.8* V_USIM	1.8	V_USIM
USIM_DATA	0.7* V_USIM	3.00	V_USIM	0.8* V_USIM	1.8	V_USIM

Table 15: Pin description

Pin name	Pin	Description
USIM_CLK	19	USIM Card Clock
USIM_RESET	18	USIM Card Reset
USIM_DATA	17	USIM Card data I/O, which has been pulled up with a 22kR resistor to V_USIM in module. Do not pull up or pull down in users' application circuit.
V_USIM	20	USIM Card Power output depends automatically on USIM mode, one is 3.0V±10%, another is 1.8V±10%. Current is less than 50mA.

3.4.2 Application Guide

It is recommended to use an ESD protection component such as ST (www.st.com) ESDA6V1W5 or ON SEMI (www.onsemi.com) SMF05C. Note that the SIM peripheral circuit should be close to the SIM card socket. The reference circuit of the 8-pin SIM card holder is illustrated in the following figure.

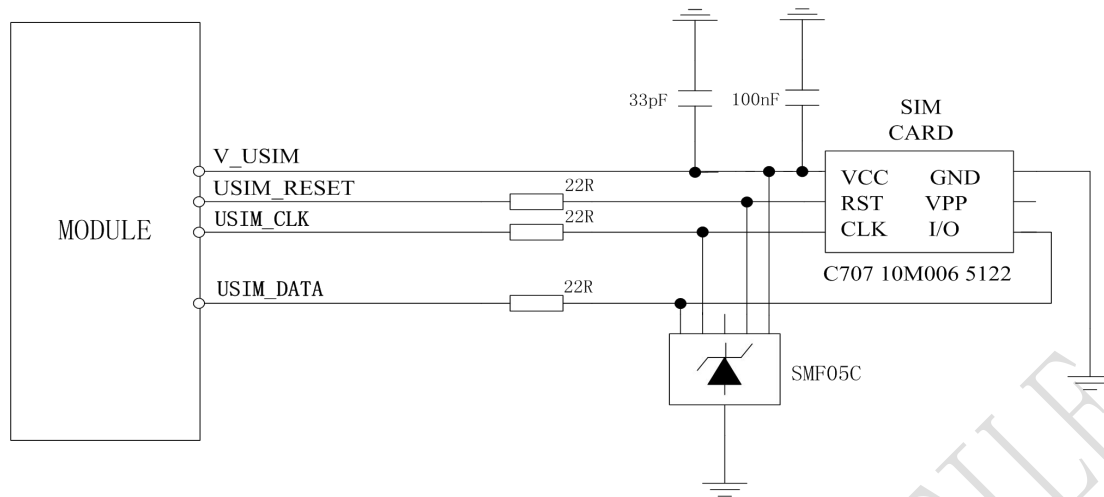

Figure 24: USIM interface reference circuit

Note: USIM_DATA has been pulled up with a 22kR resistor to V_USIM in module. A 220nF shut capacitor on V_USIM is used to reduce interference. Use AT Commands to get information in USIM card. For more detail, please refer to document [1].

3.4.3 Recommend Components

For 6 pins USIM socket, SIMCom recommend to use Amphenol **C707 10M006 512 2**. User can visit <http://www.amphenol.com> for more information about the holder.

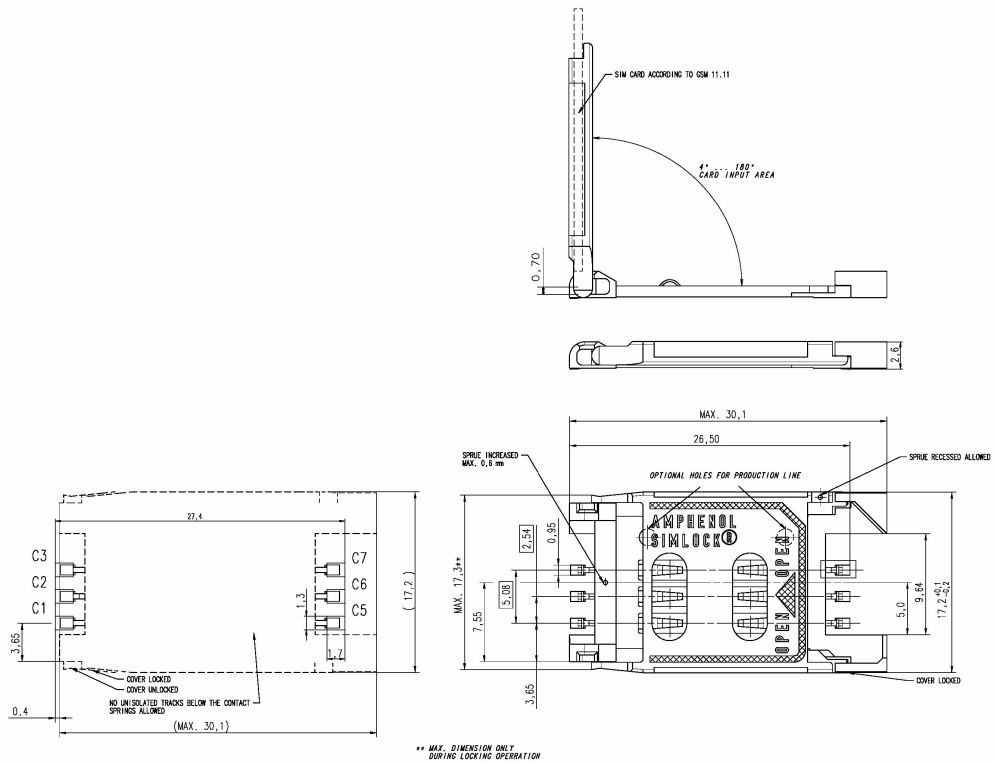

Figure 25: Amphenol SIM card socket

Table 16: Amphenol USIM socket pin description

Pin	Signal	Description
C1	USIM_VDD	SIM Card Power supply, it can identify automatically the SIM Card power mode , one is 3.0V±10%, another is 1.8V±10%.
C2	USIM_RST	SIM Card Reset.
C3	USIM_CLK	SIM Card Clock.
C5	GND	Connect to GND.
C6	VPP	Connect to USIM_VDD
C7	USIM_DATA	SIM Card data I/O.

3.5 I2C Interface

I2C is used to communicate with peripheral equipments and can be operated as either a transmitter or receiver, depending on the device function. Use AT Commands “AT+CRICC and AT+CWIIIC” to read/write register values of related peripheral equipments connected with I2C interface.

3.5.1 Pin Description

Table 17: Pin description

Pin name	Pin No.	Function
I2C_SDA	56	Serial interface data input and output
I2C_SCL	55	Serial interface clock input

3.5.2 Signal Description

Both SDA and SCL are bidirectional lines, connected to a positive supply via a pull-up resistor respectively. When the bus is free, both lines are high.

3.5.3 Design Guide

For SIM5320ALD, the data on the I2C bus can be transferred at rates up to 400kbps. The number of peripheral devices connected to the bus is solely dependent on the bus capacitance limit of 400pF. Note that PCB traces length and bending are in users' control to minimize load capacitance.

Note: I2C_SDA and I2C_SCL have been pulled up with two 2.2kR resistors to 2.6V level in module. So there is no need to pull them up in users' application circuit.

3.6 Keypad Interface

SIM5320ALD module provides a keypad interface that supports five sense lines, or columns, and five keypad rows. The interface generates an interrupt when any key is pressed. Its operation voltage is 1.8V.

3.6.1 Pin Description

Table 18: Pin description

Pin name	Pin No.	Function
KEYSENSE_N0	28	Sensing keys
KEYSENSE_N1	27	
KEYSENSE_N2	31	
KEYSENSE_N3	32	
KEYSENSE_N4	36	

KEYPAD_0	30	Driving pads
KEYPAD_1	29	
KEYPAD_2	30	
KEYPAD_3	35	
KEYPAD_4	34	

3.6.2 Application Guide

All keypad pins can be configured for GPIOs. These GPIOs also support interruption operation if used as input pins. A typical circuit about the keypad (5*5 keypad matrix) is shown in the following figure.

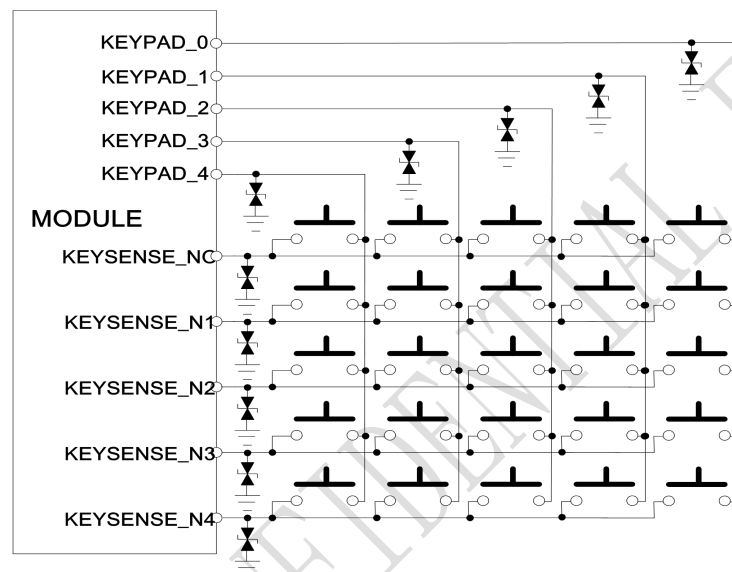

Figure 26: Reference circuit

If these pins are configured for GPIOs, the sequence is listed in the following table.

Table 19: GPIO configuration

Keypad interface	GPIO No.
KEYPAD_4	GPIO6
KEYPAD_3	GPIO7
KEYPAD_2	GPIO8
KEYPAD_1	GPIO9
KEYPAD_0	GPIO10
KEYSENSE_N4	GPIO11
KEYSENSE_N 3	GPIO12
KEYSENSE_N 2	GPIO13
KEYSENSE_N 1	GPIO14

Note: Refer to document [21] for detailed information of Keypad Application Note.

3.7 USB Interface

SIM5320ALD module contains a USB interface. This interface is compliant with the USB2.0 specification. The USB2.0 specification requires hosts such as the computer to support all three USB speeds, namely low-speed (1.5Mbps), full-speed (12Mbps) and high-speed (480Mbps). USB charging and USB-OTG is not supported.

Table 20: Electronic characteristic

Pin name	Pin No.	Input voltage scope(V)		
		Min	Typ	Max
USB_VBUS	11	4.4	5.0	5.25
USB_DP	13	They are compliant with the USB 2.0 specification.		
USB_DM	12			

3.7.1 Application Guide

Currently SIM5320ALD supports the USB suspend and resume mechanism which can help to save power. If no transaction is on USB bus, SIM5320ALD will enter suspend mode. When some events such as voice call or receiving SMS happen, SIM5320ALD will resume normal mode automatically.

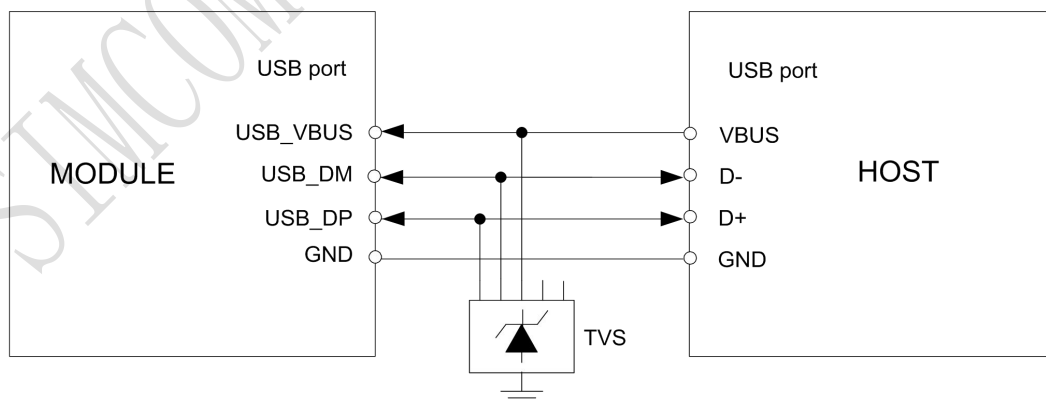

Figure 27: USB interface

Because of high bit rate on USB bus, pay attention to influence of junction capacitance of ESD component

on USB data lines. Typically, the capacitance should be less than 4pF @1MHz.

Note: The SIM5320ALD has two kinds of interface (UART and USB) to connect to host CPU. USB interface is mapped to five virtual ports: “SIMTECH USB Modem”, “SIMTECH NMEA Device”, “SIMTECH ATCOM Device”, “SIMTECH Diagnostics interface” and “SIMTECH Wireless Ethernet Adapter”.

3.8 SPI Interface

SPI interface of SIM5320ALD is master only. It provides a duplex, synchronous, serial communication link with peripheral devices. Its operation voltage is 1.8V, with clock rates up to 26 MHz.

3.8.1 Pin Description

Table 21: Electronic characteristic

Pin name	1.8V mode		
	Min	Typ	Max
SPI_CLK	1.65	1.8	1.95
SPI_CS_N	1.65	1.8	1.95
SPI_MOMI_DATA	1.65	1.8	1.95
SPI_MIMO_DATA	1.65	1.8	1.95

Table 22: Pin description

Pin name	Pin No.	Function
SPI_CS	9	SPI chip-select; not mandatory in a point-to-point connection
SPI_MISO_DATA	7	SPI master in/slave out data
SPI_CLK	6	SPI clock
SPI_MOSI_DATA	8	SPI master out/slave in data

3.9 GPIO Interface

SIM5320ALD provides a limited number of GPIO pins. All GPIOs can be configured as inputs or outputs. User can use AT Commands to read or write GPIOs status. Refer to ATC document for details.

3.9.1 Pin Description

Table 23: Electronic characteristic

Pin name	2.6V mode		
	Min	Typ	Max
GPIO1	2.5	2.6	2.7
GPIO4	2.5	2.6	2.7
GPIO40	2.5	2.6	2.7
GPIO41	2.5	2.6	2.7
GPIO43	2.5	2.6	2.7
GPIO44	2.5	2.6	2.7
GPIO42	2.5	2.6	2.7

Note: If more GPIOs need to be used, users can configure GPIO on other multiple function interfaces, such as KEYPAD. Please refer to GPIO list.

Table 24: Pin description

Pin name	Pin No.	I/O	Function
GPIO1	51	O	Output PIN as LED control for network status. If it is unused, left open.
GPIO4	54	I	Input PIN as RF operating control. H: Normal Mode L: Flight Mode If it is unused, left open.
GPIO40	49	O	Output PIN as operating status indicating of module. H: Power on L: Power off If it is unused, left open.
GPIO41	52	I/O	General input/output PIN. It can be used as wake/interrupt signal to host from module If it is unused, left open.
GPIO42	53	I/O	General Purpose Input/Output Port.
GPIO43	50	I/O	General Purpose Input/Output Port. It can be used as wake/interrupt signal to module from host. If it is unused, left open.
GPIO44	48	I/O	General Purpose Input/Output Port

Note: The output driver current of GPIOs is 1mA at the lower supply voltage and 2mA at the higher supply voltage.

3.9.2 Application Guide

Network status

GPIO1 is used to control Network Status LED; application circuit is shown below.

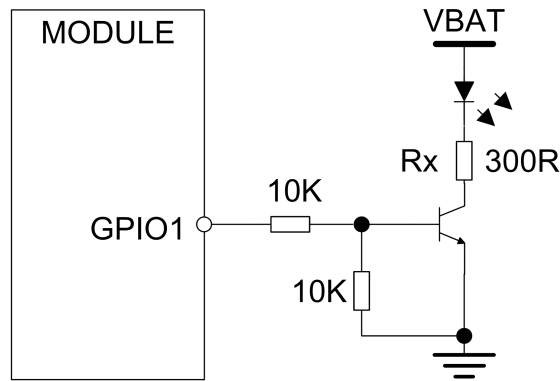

Figure 28: Application circuit

Note: The value of resistor Rx depends on LED characteristic.

Table 25: LED status

LED Status	Module Status
Always On	Searching Network/Call Connect
200ms ON, 200ms OFF	Data Transmit
800ms ON, 800ms OFF	Registered network
Off	Power off / Sleep

Flight mode control

GPIO4 controls SIM5320ALD module to enter or exit the Flight mode. In Flight mode, SIM5320ALD closes RF function to prevent interference with other equipments or minimize current consumption. Bidirectional ESD protection component is suggested to add on GPIO4.

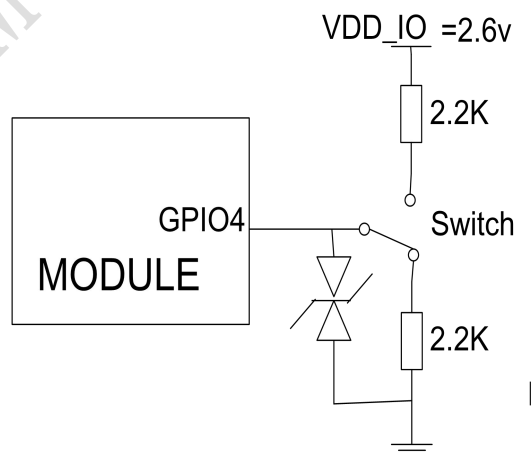

Figure 29: Flight mode switch

Table 26: Control status

GPIO4 Status	Module operation
Low Level	Flight Mode: RF is closed.
High Level	Normal Mode: RF is working.

Note:

1. When the module is powered off, make sure all digital interfaces (UART, etc) connected with peripheral devices have no voltage higher than 0.3V. If users' design cannot meet above conditions, high level voltages maybe occur in GPIO pins because current leakage from above digital interfaces may occur.

3.9.3 Pin Description

Table 27: Electronic characteristic

Pin name	DC Characteristics		
	Min	Typ	Max
PCM_CLK	-0.3	2.6	2.9
PCM_SYNC	-0.3	2.6	2.9
PCM_DOUT	-0.3	2.6	2.9
PCM_DIN	-0.3	2.6	2.9

Table 28: Pin description

Pins	Pin No.	AUX_PCM functionality	Primary PCM functionality	Description
PCM_DIN/GPIO0	74	AUX_PCM_DIN	PCM_DIN	PCM data input
PCM_SYNC/GPIO2	75	AUX_PCM_SYNC	PCM_SYNC	PCM data synchrony
PCM_DOUT/GPIO5	73	AUX_PCM_DOUT	PCM_DOUT	PCM data output
PCM_CLK/GPIO3	76	AUX_PCM_CLK	PCM_CLK	PCM data clock

3.9.4 Signal Description

The default PCM interface in SIM5320 is the auxiliary PCM interface. The data changes on the high level of PCM_CLK and is sampled at the falling edge of PCM_CLK in one period. Primary PCM is disabled after every power-on or every reset event. So user must use AT command to enable the primary PCM mode after powering on or resetting the module every time if user wants to use Primary PCM. SIM5320 PCM Interface can be operated in Master or Slave mode if it is configured to primary PCM. In Master Mode, the Module drives the clock and sync signals that are sent to the external codec. When it is in Slave

Mode, the external codec drives the clock and sync signals which are sent to the module. Both PCM modes are discussed in this section followed by additional PCM topics.

Auxiliary PCM (128 KHz PCM clock)

u-law coding is supported by the auxiliary PCM. The auxiliary codec port operates with standard long-sync timing and a 128 KHz clock. The AUX_PCM_SYNC runs at 8 KHz with 50% duty cycle. Most u-law codec support the 128 KHz clock.

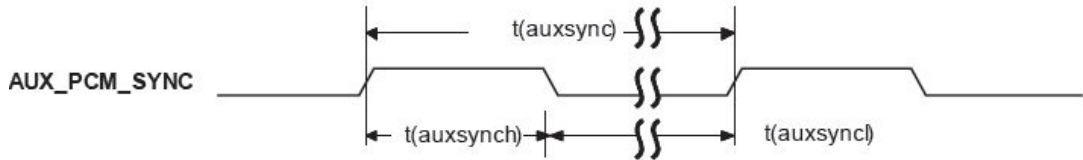

Figure 30: Synchrony timing

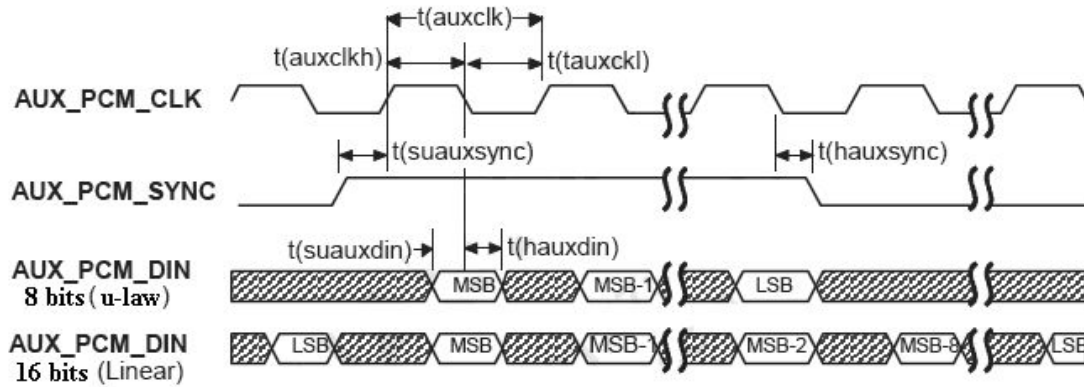

Figure 31: EXT CODEC to MODULE timing

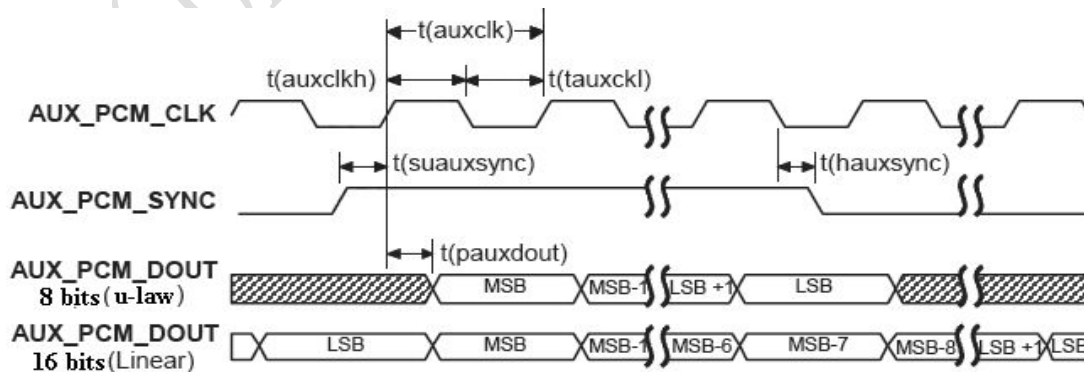

Figure 32: MODULE to EXT CODEC timing

Table 29: Timing parameters

Parameter	Description	Min	Typ	Max	Unit
T(auxsync)	AUX_PCM_SYNC cycle time	–	125	-	μs
T(auxsynch)	AUX_PCM_SYNC high time	62.4	62.5	-	μs
T(auxsyncl)	AUX_PCM_SYNC low time	62.4	62.5	-	μs
T(auxclk)*	AUX_PCM_CLK cycle time	-	7.8	–	μs
T(auxclkh)	AUX_PCM_CLK high time	3.8	3.9	–	μs
T(auxckl)	AUX_PCM_CLK low time	3.8	3.9	–	μs
T(suauxsync)	AUX_PCM_SYNC setup time high before falling edge of PCM_CLK	1.95	–	–	μs
T(hauxsync)	AUX_PCM_SYNC hold time after falling edge of PCM_CLK	1.95	–	–	μs
T(suauxdin)	AUX_PCM_DIN setup time before falling edge of AUX_PCM_CLK	70	–	–	ns
T(hauxdin)	AUX_PCM_DIN hold time after falling edge of AUX_PCM_CLK	20	–	–	ns
T(pauxdout)	Delay from AUX_PCM_CLK rising to AUX_PCM_DOUT valid	–	–	50	ns

*Note: $T(\text{auxclk}) = 1/(128 \text{ KHz})$.

Primary PCM (2048 KHz PCM clock)

SIM5320 also supports 2.048 MHz PCM data and sync timing for u-law codec. This is called the primary PCM interface. User can use AT command to take the mode you want as discussed above.

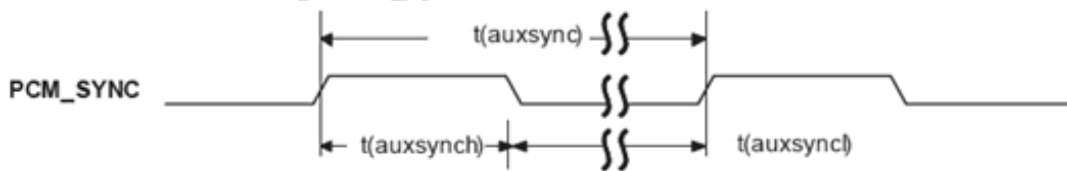

Figure 33: Synchrony timing

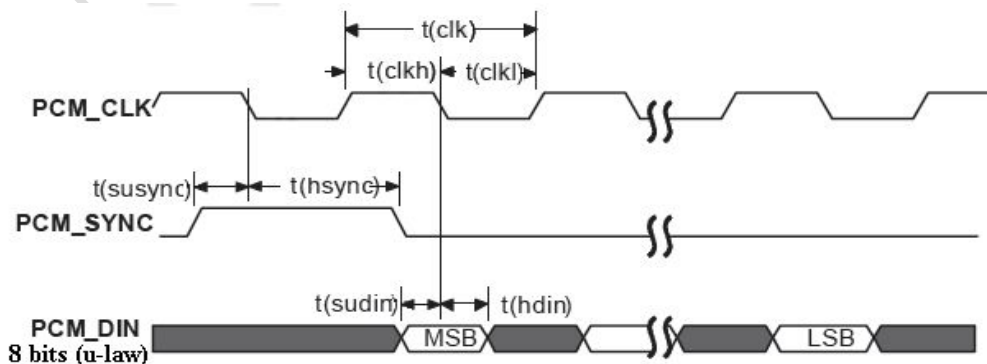

Figure 34: EXT CODEC to MODULE timing

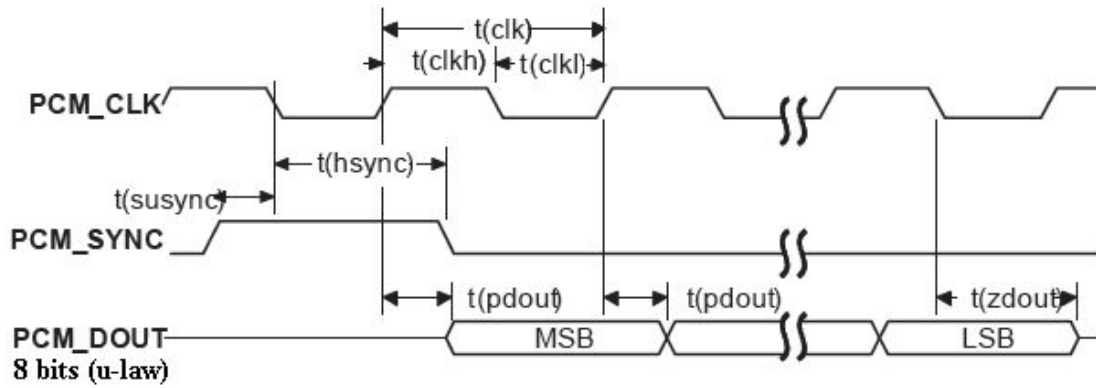

Figure 35: MODULE to EXT CODEC timing

Table 30: Timing parameters

Parameter	Description	Min	Typ	Max	Unit
T(sync)	PCM_SYNC cycle time	–	125	–	μs
T(synch)	PCM_SYNC high time	400	500	–	ns
T(syncL)	PCM_SYNC low time	–	124.5	–	μs
T(clk)	PCM_CLK cycle time	–	488	–	ns
T(clkh)	PCM_CLK high time	–	244	–	ns
T(clkl)	PCM_CLK low time	–	244	–	ns
T(susync)	PCM_SYNC setup time high before falling edge of PCM_CLK	60	–	–	ns
T(hsync)	PCM_SYNC hold time after falling edge of PCM_CLK	60	–	–	ns
T(sudin)	PCM_DIN setup time before falling edge of PCM_CLK	50	–	–	ns
T(hdin)	PCM_DIN hold time after falling edge of PCM_CLK	10	–	–	ns
T(pdout)	Delay from PCM_CLK rising to PCM_DOUT valid	–	–	350	ns
T(zdout)	Delay from PCM_CLK falling to PCM_DOUT HIGH-Z	–	160	–	ns

Note: SIM5320 can transmit PCM data by USB except for PCM interface. Please refer to document [22] for more information of PCM Application Note.

3.10 Multi-functional interface

SIM5320ALD merges functions for various applications. It can enrich users' design and lower the cost of users' hardware.

3.10.1 Sink Current Source

The dedicated pin (CURRENT_SINK) is intended for driving passive devices, such as LCD backlight, this implementation is +5V tolerant and suitable for driving white LEDs. The high-current driver can maintain a constant current which is set by the AT command “AT+ CLEDITST”, capable of up to 150 mA.

Table 31: Electronic characteristic

Symbol	Description	Min	Typ	Max	Unit
CURRENT_SINK	Input voltage	0.5	VDD	5	V
I _o	Input current	-	-	150	mA

Since the driver is ground-referenced current sink, the operating device it drives must form a current path between the VDD pin and the CURRENT_SINK pin. The following figure is for users reference.

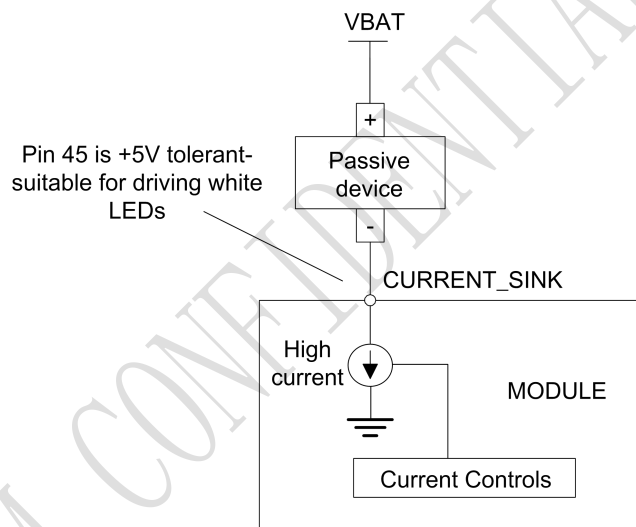

Figure 36: Current drive

Note: The sinking current can be adjusted to meet design requirement through the AT command “AT+ CLEDITST =<0>, <value>”. The “value” ranges from 0 to 15, on behalf of the current changes from 0mA to 150mA in steps of 10mA.

3.10.2 Reset Function

SIM5320ALD also have a RESET pin (PIN4) to reset the module. This function is used as an emergency reset only when AT command “AT+CPOF” and the POWER_ON pin has no effect. User can pull the RESET pin to ground, then the module will reset.

This pin is already pulled up in module, so the external pull-up resistor is not necessary. A 100nF capacitor close to the RESET pin is strongly recommended. A reference circuit is recommended in the following figure.

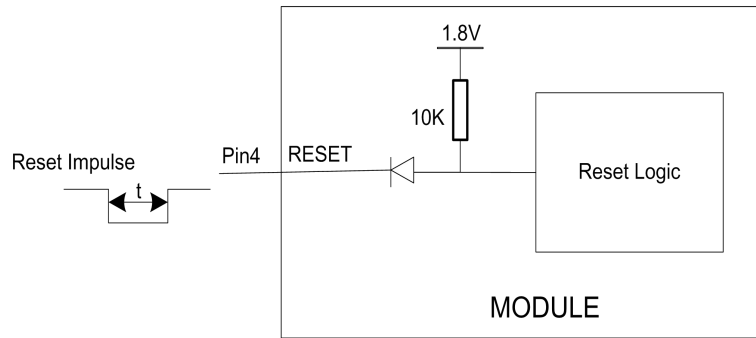

Figure 37: Reset circuit

Note: $50ms < t < 200ms$. ESD components are suggested to be used on Reset pin.

3.10.3 ADC

SIM5320ALD has a dedicated ADC that is available for digitizing analog signals such as battery voltage and so on; it is on PIN 47 and PIN 46 , namely ADC1 and ADC2 . This ADC is 12 bit successive-approximation circuit, and electronic specification is shown in the following table.

Table 32: Electronic Characteristics

Specification	Min	Typ	Max	Unit	Comments/Conditions
Resolution		12		Bits	
Differential nonlinearity	-4		+4	LSB	Analog Vdd = ADC reference 2.4MHz sample rate
Integral nonlinearity	-8		+8	LSB	
Gain Error	-2.5		+2.5	%	
Offset Error	-4		+40	LSB	
Input Range	GND		2.2V	V	
Input serial resistance		2		kΩ	Sample and hold switch resistance
Input capacitance		53		pF	
Power-down to wakeup		9.6	19.2	μs	

User can introduce a signal in the ADC pin directly and use the AT command “AT+CADC” to get the raw data which is between 0 and 4095. The data can be transformed to any type such as voltage, temperature etc. Please refer to document [1].

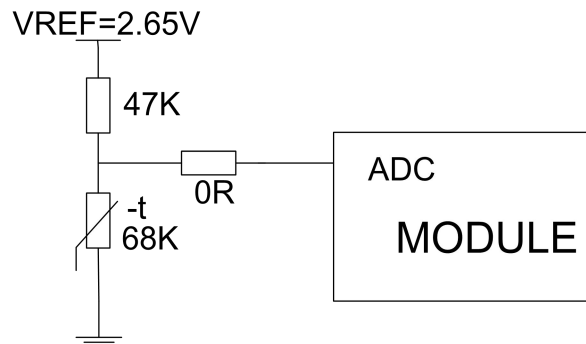

Figure 38: Reference circuit

Note: The input signal voltage value in ADC must not be higher than 2.2V.

3.10.4 LDO

SIM5320ALD has a LDO power output, namely VREG_AUX. The LDO is available and output voltage is 2.85v by default, rated for 250mA. User can switch the LDO on or off by the AT command “AT+CVAUXS” and configure its output voltage by the AT command “AT+CVAUXV”.

Table 33: Electronic characteristic

Symbol	Description	Min	Typ	Max	Unit
VREG_AUX	Output voltage	1.5	2.85	3.05	V
I _o	Output current	-	-	250	mA

4 RF Specification

4.1 RF Specification

Table 34: Conducted transmission power

Frequency	Max	Min
WCDMA 1900	24dBm +1/-3dB	-56dBm ±5dB
WCDMA 850	24dBm +1/-3dB	-56dBm ±5dB

Table 35: Operating frequencies

Frequency	Receiving	Transmission
WCDMA1900	1930~1990 MHz	1850~1910 MHz
WCDMA 850	869 ~894 MHz	824 ~849 MHz

Table 36: Conducted receive sensitivity

Frequency	Receive sensitivity
WCDMA 1900	< -108dBm
WCDMA 850	< -106dBm

4.2 Operating Specification

SIM5320ALD can support high rate data by WCDMA wireless network. In the different network environment, data transmission rate shifts depending on modulation and encoding.

Table 37: HSDPA throughput

Category	Supported	Max supported HS-DSCH codes	Theoretical max peak rate(Mbps)	Modulation
Category1		5	1.2	16QAM,QPSK
Category2		5	1.2	16QAM,QPSK
Category3		5	1.8	16QAM,QPSK
Category4		5	1.8	16QAM,QPSK
Category5	✓	5	3.6	16QAM,QPSK
Category6	✓	5	3.6	16QAM,QPSK
Category7		10	7.2	16QAM,QPSK
Category8		10	7.2	16QAM,QPSK
Category9		15	10.0	16QAM,QPSK
Category10		15	14.0	16QAM,QPSK
Category11		5	0.9	QPSK
Category12	✓	5	1.8	QPSK

Note: Actual throughput rates depend on network configuration, network loading, signal condition and so on.

4.3 Antenna Design Guide

SIM5320ALD provides RF antenna interface. Customer's antenna should be located in the host board and connected to module's antenna pad through micro-strip line or other types of RF trace and the trace impedance must be controlled in 50Ω. The maximum gain of the Main antenna gain should not exceed 1dBi considering the SAR radio. No antenna gain may be used that would exceed the 2W EIRP power limit in 1900MHz band. The input impedance of the antenna should be 50Ω, and the VSWR should be less than 2.

SIMCom recommends that the total insertion loss between the antenna pad and antenna should meet the following requirements:

- WCDMA 1900<0.9dB
- WCDMA 850<0.5dB

To facilitate the antenna tuning and certification test, a RF connector and an antenna matching circuit should be added. The following figure is the recommended circuit.

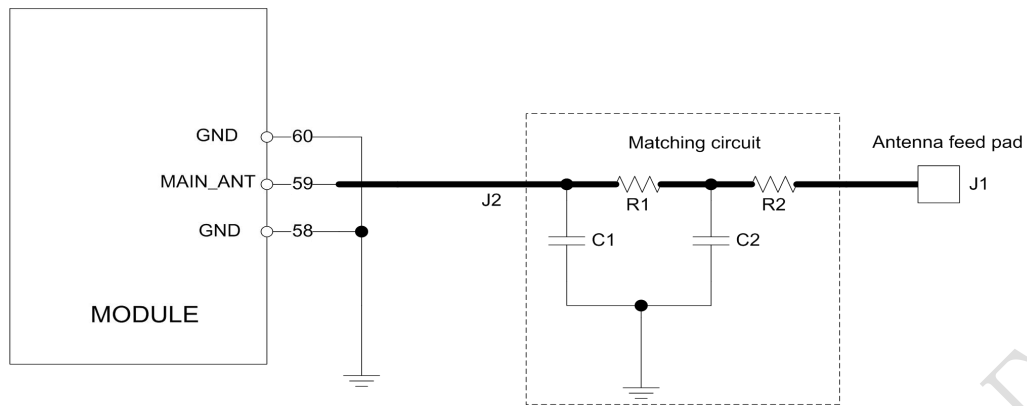

Figure 39: Antenna matching circuit

In this figure, the components R1, C1, C2 and R2 is used for antenna matching, the value of components can only be got after the antenna tuning, usually, they are provided by antenna vendor. By default, the R1, R2 are 0 ohm resistors, and the C1, C2 are reserved for tuning.

The RF test connector in the figure is used for the conducted RF performance test, and should be placed as close as to the module's antenna pin. The traces impedance between components must be controlled in 50ohm.

5 Reliability and Operating Characteristics

5.1 Electronic Characteristics

Absolute maximum rating for digital and analog pins of SIM5320ALD are listed in the following table:

Table 38: Absolute maximum ratings

Parameter	Min	Max	Unit
Voltage at digital pins (1.8v mode)	-0.3	1.8+0.3	V
Voltage at digital pins (2.6v mode)	-0.3	2.6+0.3	V
Voltage at VBAT	-0.5	6.0	V
Voltage at VRTC	1.5	3.2	V
Voltage at USB_VBUS	-0.5	6.0	V

Table 39: Recommended operating ratings

Parameter	Min	Typ	Max	Unit
Voltage at digital pins (1.8v mode)	1.65	1.8	1.95	V
Voltage at digital pins (2.6v mode)	2.5	2.6	2.7	V
Voltage at VBAT	3.3	3.8	4.2	V
Voltage at VRTC	1.5	-	3.0	V
Voltage at USB_VBUS	4.75	5	5.25	V

The operating temperature and power specification is listed in the following table.

Table 40: Operating temperature

Parameter	Min	Typ	Max	Unit
Ambient temperature	-30	25	80	°C
Storage temperature	-40	25	+85	°C

Note: SIMCom recommends user to install a heat sink on the module shielding case if SIM5320ALD operates in WCDMA band.

5.2 Operating Mode

The following table summarizes the various operating modes, each operating modes will be referred to in the following chapters.

5.2.1 Operating Modes Overview

Table 41: Operating Modes Overview

Mode	Function	
Sleep mode	WCDMA SLEEP	Module will automatically enter SLEEP mode if DTR is set to high level and there is no on air or hardware interrupt (such as GPIO interrupt or data on serial port). In this case, the current consumption of module will be reduced to the minimal level. In SLEEP mode, the module can still receive paging message, voice call and SMS.
WCDMA	WCDMA IDLE	Module has registered to the WCDMA network, and the module is ready to communicate.
	WCDMA TALK	Module is active in WCDMA mode. The power consumption depends on network settings.
HSDPA	HSDPA IDLE	Module is ready for data transmission, but no data is currently sent or received. Power consumption depends on network settings and HSDPA configuration
	HSDPA DATA	There is HSDPA data transfer (PPP or TCP or UDP) in progress. In this case, power consumption is related with network settings (e.g. power control level), uplink/downlink data rates and HSDPA configuration
Power down	Module can be powered down by the AT command “AT+CPOF” or the POWER_ON pin. The power management unit shuts down the power supply of the module, only the power supply of RTC is remained. The serial interface is not accessible. Operating voltage (connected to VBAT) remains applied.	
Minimum functionality mode	The AT command “AT+CFUN” can be used to set the module to a minimum functionality mode without removing the power supply. In this mode, the RF part of the module will not work or the SIM card will not be accessible, or both will be closed, and the serial port is still accessible. The power consumption in this mode is very low.	

5.2.2 Minimize Power Consumption

There are two modes that SIM5320ALD achieves low power consumption.

Sleep mode

If peripheral equipments stops working, and there is no on air or hardware interrupts (such as GPIO interrupts or data on UART), SIM5320ALD will enter sleep mode automatically. In this mode, SIM5320ALD can still receive paging, voice call or SMS from network. If USB interface of SIM5320ALD is connected to host CPU, but host CPU does not support USB suspending, then SIM5320ALD will not enter sleep mode. After USB is disconnected, SIM5320ALD will enter sleep mode.

Note: When UART interface is connected with host CPU, SIM5320ALD can not enter sleep mode until RXD is pulled down by the host CPU. If the module is in the idle mode, make sure to pull the RXD to low level by host CPU. SIMCom recommends using GPIO43 or UART_DTR to wake up the module from host CPU and to use GPIO41 or UART_RI to

wake up the host CPU. Before designing, pay attention to how to realize waking function and refer to Document[24] and Document[25] for more detail.

Minimum functionality mode

Minimum functionality mode ceases a majority function of module, thus minimizing the power consumption. This mode is set by the AT command which provides a choice of the functionality levels.

- AT+CFUN=0: Minimum functionality
- AT+CFUN=1: Full functionality (Default)
- AT+CFUN=4: Disable RF function of the module (Flight mode)

If SIM5320ALD has been set to minimum functionality mode, the module will firstly enter sleep mode, then the RF function and SIM card function will be closed. In this case, the serial port is still accessible, but RF function or SIM card will be unavailable. When SIM5320ALD is in minimum functionality or flight mode, it can return to full functionality by the AT command “AT+CFUN=1”.

Note: For flight mode, please refer to Chapter3.9.2.

5.3 Current Consumption

The current consumption in suspended mode and without USB connection is listed in the table below. Here, “suspended mode” means that SIM5320ALD is connected to USB bus, but it does not transfer data.

Table 42: Current consumption

UMTS Sleep Mode (without USB connection)	
WCDMA 1900	Sleep @DRX=9 2.2mA
	Sleep @DRX=8 2.7 mA
	Sleep @DRX=6 4.7mA
WCDMA 850	Sleep @DRX=9 2.2mA
	Sleep @DRX=8 2.7 mA
	Sleep @DRX=6 4.7mA
UMTS Sleep Mode (with USB suspended)	
WCDMA 1900	Sleep @DRX=9 2.4mA
	Sleep @DRX=8 2.8 mA
	Sleep @DRX=6 4.8mA
WCDMA 850	Sleep @DRX=9 2.4mA
	Sleep @DRX=8 2.8 mA
	Sleep @DRX=6 4.8mA
HSDPA Data	
WCDMA 1900	@Power 23dBm CQI=22 Typical 610mA
	@Power 21dBm CQI=5 Typical 540mA

	@Power -5dBm CQI=22	Typical 270mA
WCDMA 850	@Power 23dBm CQI=22	Typical 550mA
	@Power 21dBm CQI=5	Typical 490mA
	@Power -5dBm CQI=22	Typical 220mA

5.4 EMC and ESD Notes

EMC tests should be performed to detect any potential problems. Possible harmful emissions radiate by the application to the RF receiver in the receiver band. It is recommended to shield the sensitive components and trace with common ground and user can add beads where necessary.

Normally SIM5320ALD is mounted on customer host board. Although some ESD components have been added in SIM5320ALD, to prevent ESD, user should put some ESD components on customers' board. The ESD components should be placed beside the connectors which human body might touch, such as SIM card holder, switches, keys, etc. The following table is the SIM5320ALD ESD measurement performance; the results are from SIMCom EVB test.

Table 43: The ESD performance measurement table (Temperature: 25°C, Humidity: 45%)

Part	Contact discharge	Air discharge
VBAT,GND	±4KV	±6KV
UART,USB	±2KV	±6KV
Antenna port	±4KV	±6KV
Other ports	±2KV	±2KV

6 Guide for Production

6.1 Top and Bottom View of SIM5320ALD

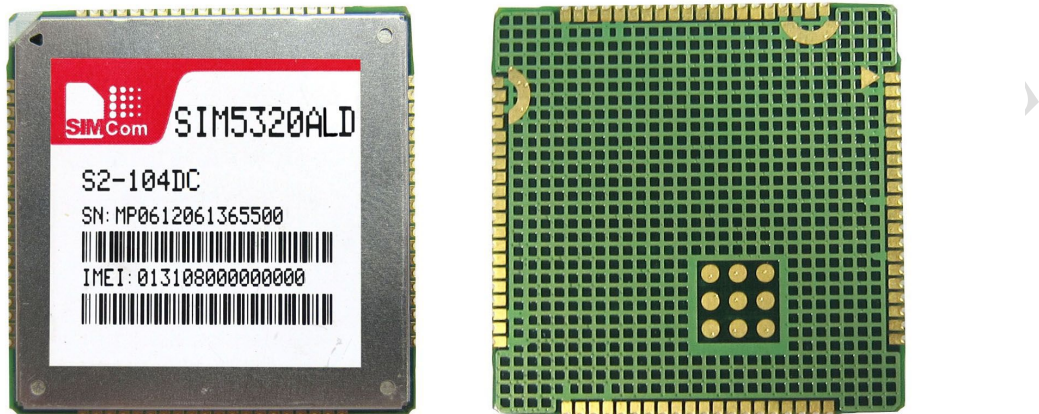

Figure 40: Top and bottom view of SIM5320ALD

These test points are only used for module manufacturing and testing. They are not for customer's application.

6.2 Typical Solder Reflow Profile

For customer convenience, SIMCom provides a typical example for a commonly used soldering profile. In final board assembly, the typical solder reflow profile will be determined by the largest component on the board, as well as the type of solder/flux used and PCB stack-up. Therefore the soldering profile shown below is only a generic recommendation and should be adjusted to the specific application and manufacturing constraints.

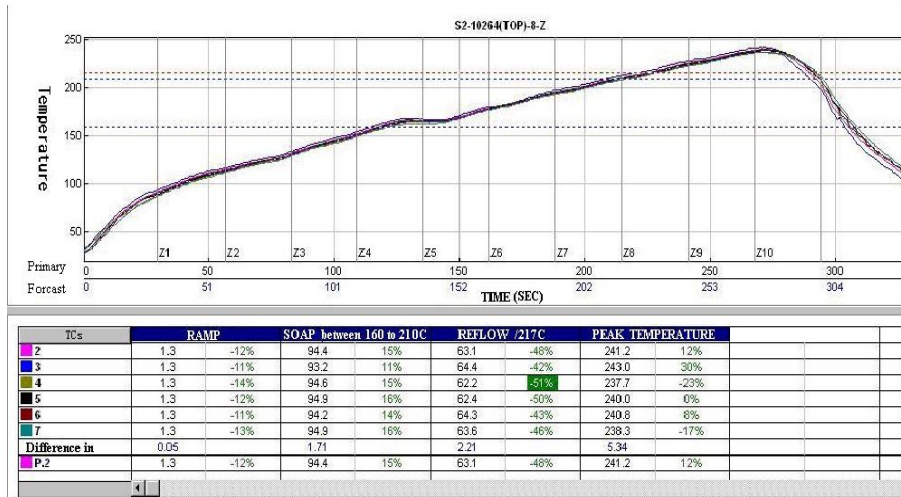

Figure 41: The ramp-soak-spike reflow profile of SIM5320ALD

For details about secondary SMT, please refer to *document [24]*.

6.3 Moisture Sensitivity Level (MSL)

SIM5320ALD is qualified to Moisture Sensitivity Level (MSL) 5 in accordance with JEDEC J-STD-020. After the prescribed time limit exceeded, users should bake modules for 192 hours in drying equipment (<5% RH) at 40° C +5° C/-0° C, or 72 hours at 85° C +5° C/-5° C. Note that plastic tray is not heat-resistant, users must not use the tray to bake at 85° C or the tray may be damaged.

6.4 Stencil Foil Design Recommendation

The recommended thickness of stencil foil is more than 0.15mm.

6.5 Recommended Pad Design

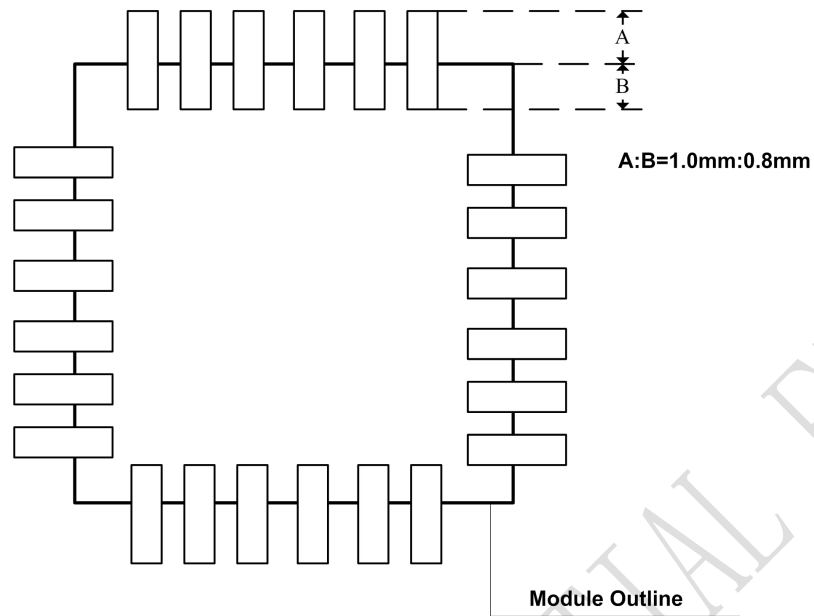

Figure 42: Recommended pad

Note: More designing details refer to Figure 6.

Appendix

A. System Design

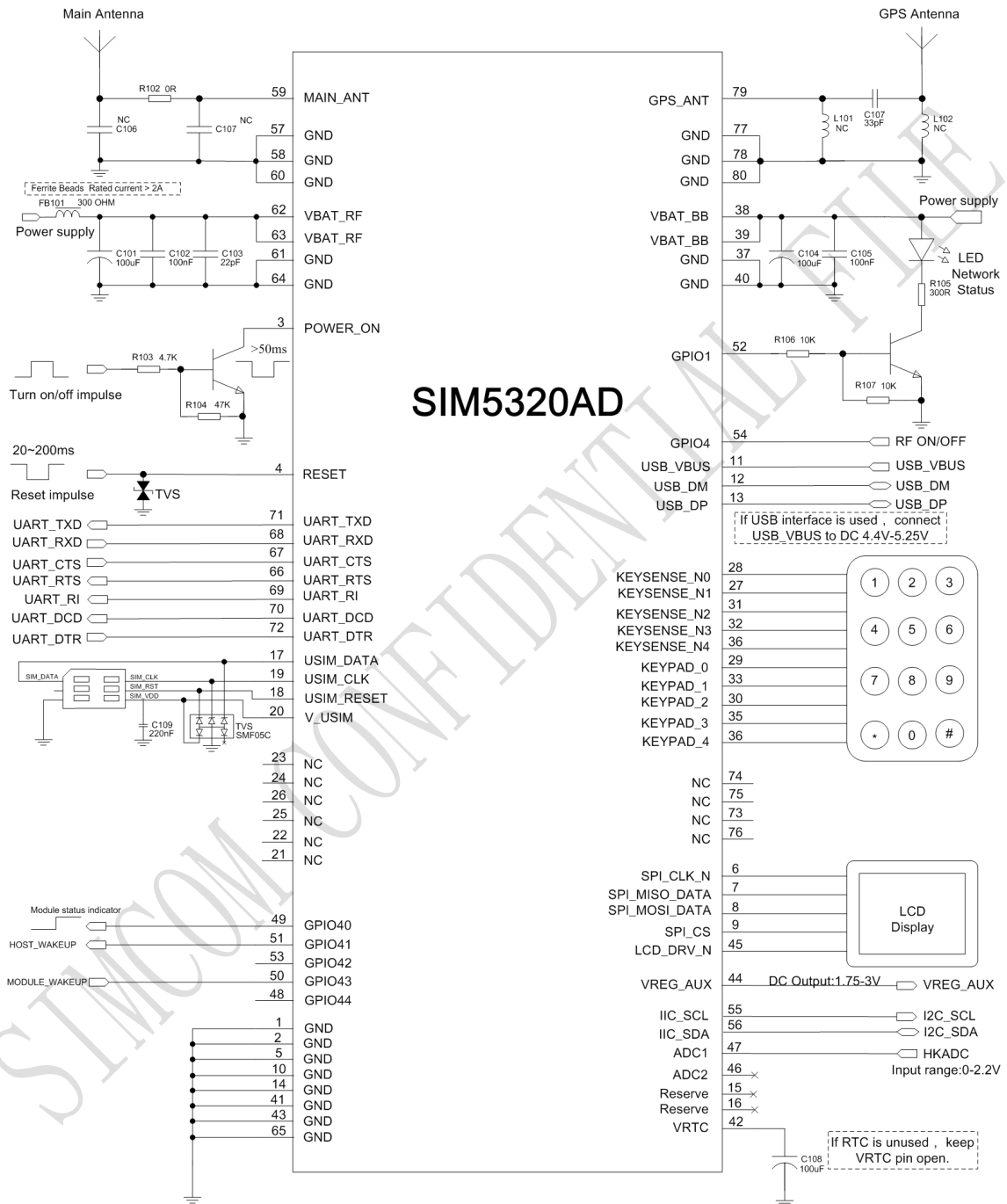

Figure 43: System design

B. SIM5320ALD GPIOs List

Table 43: SIM5320ALD GPIOs list

Name	GPIO Index	Default Function	Alternate Function
STATUS_LED	1	Status led	GPIO
RF_SWITCH	4	RF Switch	Enable/Disable RF subsystem
KEYPAD_4	6	Keypad	GPIO
KEYPAD_3	7	Keypad	GPIO
KEYPAD_2	8	Keypad	GPIO
KEYPAD_1	9	Keypad	GPIO
KEYPAD_0	10	Keypad	GPIO
KEYSENSE_N4	11	Keypad	GPIO
KEYSENSE_N3	12	Keypad	GPIO
KEYSENSE_N2	13	Keypad	GPIO
KEYSENSE_N1	14	Keypad	GPIO
KEYSENSE_N0	15	Keypad	GPIO
UART1_CTS	33	CTS	GPIO
UART1_RTS	34	RTS	GPIO
UART1_DTR	35	DTR wake up module	GPIO
UART_DCD	36	DCD	GPIO
UART_RI	37	RI wake up host	GPIO
GPIO40	40	Module power up status	GPIO
GPIO41	41	Wake up host	GPIO
GPIO42	42	GPIO	GPIO
GPIO43	43	Wake up module	GPIO
GPIO44	44	GPIO	GPIO

C. Digital I/O Characteristics

Table 44: Digital I/O characteristics

Parameter	Description	2.6V Mode			1.8V Mode			Unit
		Min	Typ	Max	Min	Typ	Max	
V _{IH}	High-level input voltage	1.69	2.6	2.9	1.17	1.8	2.1	V
V _{IL}	Low-level input voltage	-0.3	0	0.91	-0.3	0	0.63	V
V _{OH}	High-level output voltage	1.17	2.6	2.6	0.81	1.8	1.8	V
V _{OL}	Low-level output voltage	0	0	0.45	0	0	0.45	V

I _{IH}	Input leakage current	high	-	-	1	-	-	1	uA
I _{IL}	Input leakage current	low	-1	-	-	-1	-	-	uA
C _{IN}	Input capacitance		-	-	7	-	-	7	pF

Note: These parameters are for digital interface pins, such as keypad, GPIO, I²C, UART, SPI and DEBUG. The SIM5320ALD includes two kinds of voltages: 1.8v and 2.6v. Digital I/O specifications under both conditions are presented in the above tables.

D. Related Documents

Table 45: Related documents

SN	Document name	Remark
[1]	SIM5320ALD_ATC_V1.00	SIM5320ALD_ATC_V1.00
[2]	ITU-T Draft new recommendation V.25ter	Serial asynchronous automatic dialing and control
[3]	GSM 07.07	Digital cellular telecommunications (Phase 2+); AT command set for GSM Mobile Equipment (ME)
[4]	GSM 07.10	Support GSM 07.10 multiplexing protocol
[5]	GSM 07.05	Digital cellular telecommunications (Phase 2+); Use of Data Terminal Equipment – Data Circuit terminating Equipment (DTE – DCE) interface for Short Message Service (SMS) and Cell Broadcast Service (CBS)
[6]	GSM 11.14	Digital cellular telecommunications system (Phase 2+); Specification of the SIM Application Toolkit for the Subscriber Identity Module – Mobile Equipment (SIM – ME) interface
[7]	GSM 11.11	Digital cellular telecommunications system (Phase 2+); Specification of the Subscriber Identity Module – Mobile Equipment (SIM – ME) interface
[8]	GSM 03.38	Digital cellular telecommunications system (Phase 2+); Alphabets and language-specific information
[9]	GSM 11.10	Digital cellular telecommunications system (Phase 2); Mobile Station (MS) conformance specification; Part 1: Conformance specification
[10]	3GPP TS 51.010-1	Digital cellular telecommunications system (Release 5); Mobile Station (MS) conformance specification
[11]	3GPP TS 34.124	Electromagnetic Compatibility (EMC) for mobile terminals and ancillary equipment.
[12]	3GPP TS 34.121	Electromagnetic Compatibility (EMC) for mobile terminals and ancillary equipment.

[13]	3GPP TS 34.123-1	Technical Specification Group Radio Access Network; Terminal conformance specification; Radio transmission and reception (FDD)
[14]	3GPP TS 34.123-3	User Equipment (UE) conformance specification; Part 3: Abstract Test Suites.
[15]	EN 301 908-02 V2.2.1	Electromagnetic compatibility and Radio spectrum Matters (ERM); Base Stations (BS) and User Equipment (UE) for IMT-2000. Third Generation cellular networks; Part 2: Harmonized EN for IMT-2000, CDMA Direct Spread (UTRA FDD) (UE) covering essential requirements of article 3.2 of the R&TTE Directive
[16]	EN 301 489-24 V1.2.1	Electromagnetic compatibility and Radio Spectrum Matters (ERM); Electromagnetic Compatibility (EMC) standard for radio equipment and services; Part 24: Specific conditions for IMT-2000 CDMA Direct Spread (UTRA) for Mobile and portable (UE) radio and ancillary equipment
[17]	IEC/EN60950-1(2001)	Safety of information technology equipment (2000)
[18]	3GPP TS 51.010-1	Digital cellular telecommunications system (Release 5); Mobile Station (MS) conformance specification
[19]	GCF-CC V3.23.1	Global Certification Forum - Certification Criteria
[20]	2002/95/EC	Directive of the European Parliament and of the Council of 27 January 2003 on the restriction of the use of certain hazardous substances in electrical and electronic equipment (RoHS)
[21]	Keypad Application Note V1.01	Keypad Application Note V1.01
[22]	<i>Sleep_Application_Note</i>	<i>Sleep_Application_Note</i>
[23]	<i>Waking_up_Application_Note</i>	<i>Waking_up_Application_Note</i>
[24]	Module secondary-SMT-UGD	SMT Note
[25]	SIM5xxx_Automatic_power_on_Application_Note	SIM5xxx_Automatic_power_on_Application_Note

E. Terms and Abbreviations

Table 46: Terms and Abbreviations







Abbreviation	Description
ADC	Analog-to-Digital Converter
ARP	Antenna Reference Point
BER	Bit Error Rate
BTS	Base Transceiver Station
CS	Coding Scheme
CSD	Circuit Switched Data
CTS	Clear to Send
DAC	Digital-to-Analog Converter
DRX	Discontinuous Reception

DSP	Digital Signal Processor
DTE	Data Terminal Equipment (typically computer, terminal, printer)
DTR	Data Terminal Ready
DTX	Discontinuous Transmission
EFR	Enhanced Full Rate
EGSM	Enhanced GSM
EMC	Electromagnetic Compatibility
ESD	Electrostatic Discharge
ETS	European Telecommunication Standard
FCC	Federal Communications Commission (U.S.)
FD	SIM fix dialing phonebook
FDMA	Frequency Division Multiple Access
FR	Full Rate
GMSK	Gaussian Minimum Shift Keying
GPRS	General Packet Radio Service
GSM	Global Standard for Mobile Communications
HR	Half Rate
I2C	Inter-Integrated Circuit
IMEI	International Mobile Equipment Identity
Inorm	Normal Current
Imax	Maximum Load Current
kbps	Kilo bits per second
Li-Ion	Lithium-Ion
MO	Mobile Originated
MS	Mobile Station (GSM engine), also referred to as TE
MT	Mobile Terminated
PAP	Password Authentication Protocol
PBCCH	Packet Switched Broadcast Control Channel
PCB	Printed Circuit Board
PCS	Personal Communication System, also referred to as GSM 1900
RF	Radio Frequency
RMS	Root Mean Square (value)
RTC	Real Time Clock
Rx	Receive Direction
SIM	Subscriber Identification Module
SMS	Short Message Service
SPI	serial peripheral interface
TDMA	Time Division Multiple Access
TE	Terminal Equipment, also referred to as DTE
TX	Transmit Direction
UART	Universal Asynchronous Receiver & Transmitter
VSWR	Voltage Standing Wave Ratio
Vmax	Maximum Voltage Value
Vnorm	Normal Voltage Value
Vmin	Minimum Voltage Value
VIHmax	Maximum Input High Level Voltage Value
VIHmin	Minimum Input High Level Voltage Value
VILmax	Maximum Input Low Level Voltage Value

VILmin	Minimum Input Low Level Voltage Value
VImax	Absolute Maximum Input Voltage Value
VImin	Absolute Minimum Input Voltage Value
VOHmax	Maximum Output High Level Voltage Value
VOHmin	Minimum Output High Level Voltage Value
VOLmax	Maximum Output Low Level Voltage Value
VOLmin	Minimum Output Low Level Voltage Value
SM	SIM phonebook
NC	Not connect
EDGE	Enhanced data rates for GSM evolution
HSDPA	High Speed Downlink Packet Access
HSUPA	High Speed Uplink Packet Access
ZIF	Zero intermediate frequency
WCDMA	Wideband Code Division Multiple Access
VCTCXO	Voltage control temperature-compensated crystal oscillator
USIM	Universal subscriber identity module
UMTS	Universal mobile telecommunications system
UART	Universal asynchronous receiver transmitter

F. Safety Caution

Table 47: Safety caution

Marks	Requirements
	When in a hospital or other health care facility, observe the restrictions about the use of mobiles. Switch the cellular terminal or mobile off, medical equipment may be sensitive to not operate normally for RF energy interference.
	Switch off the cellular terminal or mobile before boarding an aircraft. Make sure it is switched off. The operation of wireless appliances in an aircraft is forbidden to prevent interference with communication systems. Forget to think much of these instructions may lead to the flight safety or offend against local legal action, or both.
	Do not operate the cellular terminal or mobile in the presence of flammable gases or fumes. Switch off the cellular terminal when you are near petrol stations, fuel depots, chemical plants or where blasting operations are in progress. Operation of any electrical equipment in potentially explosive atmospheres can constitute a safety hazard.
	Your cellular terminal or mobile receives and transmits radio frequency energy while switched on. RF interference can occur if it is used close to TV sets, radios, computers or other electric equipment.
	Road safety comes first! Do not use a hand-held cellular terminal or mobile when driving a vehicle, unless it is securely mounted in a holder for hands free operation. Before making a call with a hand-held terminal or mobile, park the vehicle.
	<p>GSM cellular terminals or mobiles operate over radio frequency signals and cellular networks and cannot be guaranteed to connect in all conditions, for example no mobile fee or a invalid SIM card. While you are in this condition and need emergent help, please remember using emergency calls. In order to make or receive calls, the cellular terminal or mobile must be switched on and in a service area with adequate cellular signal strength.</p> <p>Some networks do not allow for emergency call if certain network services or phone features are in use (e.g. lock functions, fixed dialing etc.). You may have to deactivate those features before you can make an emergency call.</p> <p>Also, some networks require that a valid SIM card be properly inserted in the cellular terminal or mobile.</p>

Contact us:

Shanghai SIMCom Wireless Solutions Ltd.

Add: SIM Technology Building, No.633, Jinzhong Road, Changning District, Shanghai P.R. China 200335

Tel: +86 21 3235 3300

Fax: +86 21 3235 3301

URL: www.sim.com/wm

SIMCOM CONFIDENTIAL FILE