



## SDB670 BASE STATION

### SERVICE MANUAL

TNM-M-E-0032, Issue – 1.2  
July 2013

The contents of this document are **CONFIDENTIAL** and must not be disclosed to a third party without permission in writing from Simoco.



Field House,  
Uttoxeter Old Road  
Derby  
DE1 1NH

Tel: +44 (0) 1332 375500

FAX: +44 (0) 1332 375501

<http://www.simocogroup.com>



1270 Ferntree Gully Road,  
Scoresby  
Victoria, 3179  
Australia

Tel: +61 (0)3 9730 3999

FAX: +61 (0)3 9730 3988

<http://www.simocogroup.com>

©Simoco 2013

## PREFACE

### DECLARATION

This Service Manual covers the SDB670 Digital Mobile Radio (DMR) Base Station.

Any performance figures quoted are subject to normal manufacturing and service tolerances. The right is reserved to alter the equipment described in this manual in the light of future technical development.

Changes or modifications not expressly approved by the party responsible for compliance could void the user's authority to operate the equipment.

### NOTE.

***The manufacturer is not responsible for any radio or television interference caused by unauthorized modifications to this equipment. Such modifications could void the user's authority to operate the equipment.***

### COPYRIGHT

All information contained in this document is the property of Simoco. All rights are reserved. This document may not, in whole or in part, be copied, photocopied, reproduced, translated, stored, or reduced to any electronic medium or machine-readable form, without prior written permission from Simoco.

### COMPUTER SOFTWARE COPYRIGHTS

The AMBE+2™ voice coding Technology embodied in this product is protected by intellectual property rights including patent rights, copyrights and trade secrets of Digital Voice Systems, Inc. This voice coding Technology is licensed solely for use within this Communications Equipment. The user of this Technology is explicitly prohibited from attempting to extract, remove, decompile, reverse engineer, or disassemble the Object Code, or in any other way convert the Object Code into a human-readable form. U.S. Patent Nos. #6,912,495 B2, #6,199,037 B1, #5,870,405, #5,826,222, #5,754,974, #5,701,390, #5,715,365, #5,649,050, #5,630,011, #5,581,656, #5,517,511, #5,491,772, #5,247,579, #5,226,084 and #5,195,166.

### DISCLAIMER

There are no warranties extended or granted by this document. Simoco accepts no responsibility for damage arising from use of the information contained in the document or of the equipment and software it describes. It is the responsibility of the user to ensure that use of such information, equipment and software complies with the laws, rules and regulations of the applicable jurisdictions.

### INDUSTRY CANADA – RADIO EQUIPMENT WARNING STATEMENT

Under Industry Canada regulations, this radio transmitter may only operate using an antenna of a type and maximum (or lesser) gain approved for the transmitter by Industry Canada. To reduce potential radio interference to other users, the antenna type and its gain should be so chosen that the Equivalent Isotropically Radiated Power (EIRP) is not more than that necessary for successful communication.

To comply with Industry Canada RF radiation exposure limits for general population, the antenna(s) used for this transmitter must be installed on outdoor permanent structures such that a minimum separation distance of 2 m is maintained between the radiator (antenna) and all persons at all times. In addition the antennas of this transmitter must not be collocated with other antennas or transmitters.

## EQUIPMENT AND MANUAL UPDATES

In the interests of improving the performance, reliability or servicing of the equipment, Simoco reserves the right to update the equipment or this document or both without prior notice.

## ERRORS AND OMISSIONS

The usefulness of this publication depends upon the accuracy and completeness of the information contained within it. Whilst every endeavour has been made to eliminate any errors, some may still exist. It is requested that any errors or omissions noted should be reported to either of the following who are part of the Simoco group:



Field House  
Uttoxeter Old Road, Derby  
DE1 1NH  
United Kingdom

Tel: +44 (0) 871 741 1050

E-mail: [customer.service@simocogroup.com](mailto:customer.service@simocogroup.com)



1270 Ferntree Gully Road  
Scoresby  
Victoria. 3179  
Australia

Tel: +61 (0)3 9730 3800

E-mail: [inquiry.aus@simocogroup.com](mailto:inquiry.aus@simocogroup.com)

## DOCUMENT HISTORY

Issue	Date	Comments
1.0	21 May 2013	Initial Issue.
1.1	11 July 2013	Update of Tx/Rx specifications and changes to Support email addresses.
1.2	18 July 2013	IC Radio Equipment Warning Statement included.

## RELATED DOCUMENTS

1. **TNM-I-E-0041. SDB670 Base Station – Installation Guide, Issue 1.1, dated July 2013.**
2. **TNM-S-E-0005. SDM600 Series – Issue 4.0 Circuit Diagrams, Issue 1.1, dated July 2013.**

To order printed copies of this or any of the above publications, please contact Simoco. See the **Support** page for contact information.

A comprehensive list of documentation is available for download on the Simoco website <http://www.simocogroup.com> via the Partner Portal.

# TABLE OF CONTENTS

	Page
Title Page .....	1
Preface .....	2
Table of Contents (This List) .....	4
List of Figures .....	
List of Tables .....	
Personal Safety .....	
Equipment Safety .....	
WEEE Notice .....	
General Notes .....	
Support .....	
Abbreviations .....	
<b>1 INTRODUCTION .....</b>	<b>16</b>
1.1 SIMOCO Xd SDB600 SERIES .....	16
1.2 FEATURES.....	16
<b>2 PRODUCT CODES .....</b>	<b>17</b>
2.1 ORDER CODE .....	17
2.2 FACTORY CODE.....	18
2.3 RADIO LABEL .....	18
2.3.1 Radio Serial Number.....	18
2.4 MAC ADDRESS .....	19
<b>3 SPECIFICATIONS.....</b>	<b>20</b>
3.1 GENERAL .....	20
3.2 TX SPECIFICATIONS .....	20
3.3 RECEIVER.....	21
<b>4 DESCRIPTION .....</b>	<b>22</b>
4.1 SDM600 SUB-ASSEMBLIES .....	23
4.2 FRONT PANEL .....	24
4.2.1 LED Indicators.....	24
4.3 REAR PANEL CONNECTORS .....	24
4.3.1 Tx/Rx Connections.....	25
4.3.2 Power Input Connection .....	26
4.3.3 Earth Point .....	26
4.3.4 P4 USB Type B Connector.....	26
4.3.5 P3 USB Type A Connector.....	27
4.3.6 P5 Ethernet.....	27
4.3.7 S2 Serial Port.....	27
4.3.8 Facilities Connector.....	28
4.3.9 Battery Backup.....	29
<b>5 TECHNICAL DESCRIPTION.....</b>	<b>30</b>

<b>5.1</b>	<b>MMI BOARD</b> .....	<b>30</b>
5.1.1	Description.....	30
<b>5.2</b>	<b>CONTROL BOARD</b> .....	<b>30</b>
5.2.1	Circuit Board Layout.....	30
5.2.2	Circuit Description.....	31
5.2.2.1	Power.....	31
5.2.2.2	Main Processor.....	31
5.2.2.3	DSP Co-processor.....	31
5.2.2.4	Ethernet Interface.....	31
5.2.2.5	Radio Interface.....	31
5.2.2.6	USB A.....	31
5.2.2.7	USB B.....	31
5.2.2.8	Digital I/O.....	31
5.2.2.9	Fan Control.....	31
5.2.2.10	Analogue Outputs.....	31
5.2.2.11	Analogue Inputs.....	32
5.2.2.12	GPS Input.....	32
5.2.2.13	External Power.....	32
5.2.2.14	RS232 Serial Interface (DB9).....	32
5.2.2.15	Expansion Header.....	32
<b>5.3</b>	<b>TRANSMITTER AND RECEIVER MODULES</b> .....	<b>32</b>
5.3.1	Control.....	32
5.3.1.1	DSP and FPGA.....	32
5.3.1.2	DSP Clock Oscillator.....	33
5.3.1.3	Analogue Inputs and Outputs.....	33
5.3.1.4	Flash Memory.....	33
5.3.2	Receiver.....	34
5.3.2.1	Front End Filters and RF Amplifier.....	34
5.3.2.2	Mixer and IF Section.....	34
5.3.2.3	IF Analogue to Digital Convertor.....	35
5.3.3	Transmitter.....	35
5.3.3.1	Drivers and PA Stages.....	35
5.3.3.2	Power Control.....	36
5.3.3.3	Antenna Switch and Harmonic Filter.....	36
5.3.3.4	Temperature Sensor.....	36
5.3.4	Frequency Synthesiser.....	37
5.3.4.1	General.....	37
5.3.4.2	Fractional PLL.....	37
5.3.4.3	Negative Bias Generator and Loop Filter.....	37
5.3.4.4	Reference Oscillator.....	37
5.3.4.5	VCO's.....	38
5.3.5	Audio Processing.....	38
5.3.5.1	Receiver Audio.....	38
5.3.5.2	Transmitter Audio.....	39
5.3.6	Power Supplies.....	39
5.3.6.1	Power On/Off Function.....	39
5.3.6.2	Radio Power Supplies.....	40
<b>6</b>	<b>MAINTENANCE</b> .....	<b>43</b>
<b>6.1</b>	<b>TORQUE SETTINGS</b> .....	<b>43</b>
<b>6.2</b>	<b>DISASSEMBLY</b> .....	<b>43</b>
6.2.1	To Remove the Base from a Rack.....	43
6.2.2	To Open the SDB670.....	43
6.2.3	To Remove the Tx Assembly.....	43

6.2.4	To Remove the Rx Assembly .....	44
6.2.5	To Remove the Control Board.....	45
6.2.6	To Remove the PSU and Fuse Board Assembly (AC version only).....	46
6.2.7	To Remove the Fan Assembly .....	47
6.2.8	To Remove the MMI Board Panel .....	47
6.2.9	To Remove the Internal Fan Assembly .....	47
<b>6.3</b>	<b>REASSEMBLY .....</b>	<b>48</b>
6.3.1	To Fit the Internal Fan Assembly.....	48
6.3.2	To Fit the MMI Board.....	48
6.3.3	To Fit the Heat Sink Fan Assembly .....	48
6.3.4	To Fit the PSU and Fuse Board Assembly (AC version only) .....	48
6.3.5	To Fit the Control Board .....	49
6.3.6	To Fit the Rx Assembly .....	49
6.3.7	To fit the Tx Assembly.....	50
<b>7</b>	<b>SPARES.....</b>	<b>52</b>
7.1	<b>SERVICE CONCEPT .....</b>	<b>52</b>
7.2	<b>LEVEL 2 SPARES SCHEDULE .....</b>	<b>52</b>
7.2.1	SDB670 DMR Base Station.....	52
7.3	<b>WARRANTY .....</b>	<b>53</b>
7.3.1	Service Within and Out Of Warranty.....	53
7.3.2	Ancillary Items.....	53
7.3.3	Unpacking Equipment .....	53
7.4	<b>SOFTWARE POLICY.....</b>	<b>53</b>

## APPENDICES

### A DMR CONTROL BOARD BLOCK DIAGRAM.

## LIST OF FIGURES

	Page
Figure 1. Simoco Xd, SDB600 Series Base Station. ....	16
Figure 2. Internal Layout of DMR Base Station (AC version).....	22
Figure 3. Internal Layout of DMR Base Station (DC version).....	23
Figure 4. SDB670 Front Panel. ....	24
Figure 5. Layout of Rear Panel (AC version).....	25
Figure 6. Layout of Rear Panel (DC version).....	25
Figure 7. AC and DC power connectors. ....	26
Figure 8. Digital Inputs and Outputs. ....	29
Figure 9. Control Board Layout. ....	30
Figure 10. Tx and Rx Modules – VHF/UHF Block Diagram. ....	42
Figure 11. Removal of Tx Assembly.....	44
Figure 12. Removal of Rx Assembly. ....	45
Figure 13. Removing the Control Board. ....	46
Figure 14. Removal of PSU and Fuse Board Assembly (AC version only). ....	46
Figure 15. Removal of Fan Assembly. ....	47
Figure 16. Heat Pipe Array.....	50
Figure A1. DMR Control Board Block Diagram. ....	55

## LIST OF TABLES

	Page
Table 1. Order Code Information.....	17
Table 2. Factory Code Information.....	18
Table 3. Radio Serial Number Information. ....	19
Table 4. General Specifications. ....	20
Table 5. 25 W Transmitter Specifications.....	20
Table 6. Receiver Specifications.....	21
Table 7. Details of Front Panel LED Indicators.....	24
Table 8. Rear Panel Connections. ....	25
Table 9. DC Power Connector Pin-outs. ....	26
Table 10. USB Type B Connector Pin-outs. ....	26
Table 11. USB Type A Connector Pin-outs. ....	27
Table 12. Ethernet RJ45 Connector Pin-outs. ....	27
Table 13. S2 Serial Port Connector Pin-outs.....	27
Table 14. Facilities Connector Pin-outs.....	28
Table 15. PSU TB1 Connections. ....	49
Table 16. Service Levels.....	52
Table 17. Service Level 2 Recommended Spares Schedule.....	53

## PERSONAL SAFETY

### Safety Precautions

These Safety Precautions, Warnings and Cautions advise personnel of specific hazards which may be encountered during the procedures contained in this document and that control measures are required to prevent injury to personnel, and damage to equipment and/or the environment.

Before commencing the installation or any maintenance of this equipment, personnel are to acquaint themselves with all risk assessments relevant to the work site and the task. They must then comply with the control measures detailed in those risk assessments.

References covering safety regulations, health hazards and hazardous substances are detailed under the **WARNINGS** section below. These are referred to in the tasks, when encountered.

Adequate precautions must be taken to ensure that other personnel do not activate any equipment that has been switched off for maintenance. Refer to the relevant Electrical Safety Regulations appropriate to the country of operation.

Where dangerous voltages are exposed during a task, safety personnel are to be provided as detailed in the Electricity at Work regulations 1989. Where safety personnel are required for any other reason, management are to ensure that the personnel detailed are aware of the hazard and are fully briefed on the action to be taken in an emergency.

Where equipment contains heavy components or units that require lifting, lowering, pulling or pushing operations to be performed on them during maintenance tasks, all managers and tradesmen are to be conversant with the Manual Handling Operations Regulations 1992, ISBN 0110259203.

### Hazardous Substances

Before using any hazardous substance or material, the user must be conversant with the safety precautions and first aid instructions:

- On the label of the container in which it was supplied.
- On the material Safety Data Sheet.
- In any local Safety Orders and Regulations.

### Warnings

#### Beryllium and Beryllia



#### **WARNING**

**BERYLLIUM AND BERYLLIA. THE POWER AMPLIFIER (PA) MODULE (IF FITTED) USES SEMICONDUCTOR DEVICES CONTAINING BERYLLIUM OXIDE. REFER TO THE CONTROL OF SUBSTANCES HAZARDOUS TO HEALTH REGULATIONS (COSHH) 2002 AND/OR THE APPROPRIATE SAFETY DATA SHEET.**



### Heavy Equipment



**WARNING**  
**HEAVY EQUIPMENT. THE WEIGHT OF A FULLY ASSEMBLED DMR BASE IN THE WALL MOUNT IS APPROX 10 KG (2 MEN TO LIFT). REFER TO THE MANUAL HANDLING OPERATIONS REGULATIONS 1992.**

### Radio Frequency Radiation



**WARNING**  
**RADIO FREQUENCY RADIATION. A RADIO FREQUENCY (RF) RADIATION HAZARD EXISTS IN THIS EQUIPMENT. TO AVOID RF INJURY, DO NOT TOUCH THE ANTENNA WHEN THE TRANSMITTER IS IN USE. DO NOT OPERATE TRANSMITTER WITH ANTENNA DISCONNECTED.**

### Dangerous Voltages

Dangerous voltages exist in this equipment, for the appropriate Safety precautions, refer to the Electrical Safety Regulations appropriate to the country of operation.

Depending on the variant, the DMR Base Station may be fitted with an Internal AC Power Supply. If an Internal AC Power Supply is fitted, a standard IEC mains connector will be fitted on the rear panel (refer to the **Section 3 - Description** for further details).



**WARNING**  
**THIS EQUIPMENT MUST TO BE CONNECTED TO A MAINS POWER SUPPLY THAT HAS A SAFETY EARTH CONNECTION.**



**WARNINGS**  
**DO NOT CONNECT THE MAINS ELECTRICITY SUPPLY UNTIL THE INSTALLATION IS COMPLETE**  
**DISCONNECT THE MAINS ELECTRICITY SUPPLY BEFORE WORKING ON AN OPEN WALL MOUNT OR POWER SUPPLY UNIT TRAY**

### Heat Sink Compound



**WARNING**  
**HEAT SINK COMPOUND. DOW CORNING DC340 HEAT SINK COMPOUND IS USED IN THE MAINTENANCE OF THIS EQUIPMENT. REFER TO THE COSHH REGULATIONS 2002 AND THE APPROPRIATE PRODUCT SAFETY DATA SHEET.**

## EQUIPMENT SAFETY

### Installation and Maintenance

The DMR Series of base stations should only be installed and maintained by qualified personnel.

#### Cautions



#### CAUTION

The Antenna system must be protected against lightning by means of an earthing system and surge protection device.  
Do not connect Antenna Lightning conductors to the base station or Mains Earth.



#### CAUTION

**EQUIPMENT DAMAGE.** During assembly operations, the Torque settings must be adhered to or damage to the equipment may result.

#### Maintenance Precautions



#### CAUTION

Electrostatic Discharge Sensitive Devices (ESDS Devices). This equipment contains ESDS Devices, the handling procedures detailed in BS EN 61340-5-1:2007 or ANSI/ESD S20.20-1999 are to be observed.

## WASTE ELECTRICAL AND ELECTRONIC EQUIPMENT (WEEE) NOTICE



The Waste Electrical and Electronic Equipment (WEEE) Directive became law in most EU countries during 2005. The directive applies to the disposal of waste electrical and electronic equipment within the member states of the European Union.

As part of the legislation, electrical and electronic equipment will feature the crossed out wheeled bin symbol (see image at left) on the product or in the documentation to show that these products must be disposed of in accordance with the WEEE Directive.

In the European Union, this label indicates that this product should not be disposed of with domestic or "ordinary" waste. It should be deposited at an appropriate facility to enable recovery and recycling.

---

## GENERAL NOTES

### MANUAL COMPILATION

This manual provides detailed information on the SDB670 DMR Base Station including Introduction, Specifications, General Description, Technical Description, Maintenance, and Spares.

Details of both “basic” and “optional units” have been included in this Service Manual, therefore, some material may not be relevant to every system. Configuration is dependent upon the specification by the customer when the equipment was ordered and installed.

The manual has been compiled with a two-tier maintenance policy in mind, i.e. first-line fault location and repair by replacement, followed by subsequent bench-testing of sub-assemblies to specification. Consequently, some “overlap” and/or duplication of information has resulted.

### PAGINATION

This manual is divided into a number of sections, each section deals with one aspect of the system.

Following initial issue, any page that has been amended or updated will also bear an updated reference.

### PARTS LISTING

A Composite List of Replaceable Assemblies (i.e. a list of all components used in the system) is included at **Section 7**.

## SUPPORT

### CONTACT INFORMATION

At Simoco we welcome your comments, feedback and suggestions. Departmental contacts have been provided for your quick reference below.



#### UK Customer Services

Email: [customer.service@simocogroup.com](mailto:customer.service@simocogroup.com)  
Tel: UK: 08717 411 050  
International: +44 (0) 1332 375 671  
Fax: UK: 08717 411 049  
International: +44 (0) 1332 376 672

#### Sales

Email [sales@simocogroup.com](mailto:sales@simocogroup.com)

#### Marketing

Email [marketing@simocogroup.com](mailto:marketing@simocogroup.com)

#### Technical Support

Email: [techsupport@simocogroup.com](mailto:techsupport@simocogroup.com)

#### Technical Support Helpline

Tel: UK: 08717 411 040  
International: +44 (0) 1332 375 671



#### Australian Customer Services

Email: [inquiry.aus@simocogroup.com](mailto:inquiry.aus@simocogroup.com)  
Tel: Within Australia: 1300 363 607  
International: +61 3 9730 3800



#### US Customer Services

Email: [customerservice@simocoamericas.com](mailto:customerservice@simocoamericas.com)  
Tel: +1 (0) 877 848 3876

#### US Technical Support

Email: [techsupport@simocoamericas.com](mailto:techsupport@simocoamericas.com)

## ABBREVIATIONS

The following abbreviations are used through out this document. Whenever practicable, wherever the abbreviation is first used the full meaning is given with the abbreviation in parenthesis, after that only the abbreviation will be used.

### LIST OF ABBREVIATIONS

Abbreviation	Meaning
'.....'	Reference to a feature, label or setting exactly as it is displayed on the equipment or software application.
2U	Two Units (U = vertical measurement of 44.45 mm for equipment racks)
AC	Alternating Current
ADC	Analogue to Digital Converter
AFC	Automatic Frequency Control
AGC	Automatic Gain Control
BER	Bit Error Rate
BNC	Bayonet Neill-Concelman
CoDec	Coder Decoder
COSHH	Control Of Substances Hazardous to Health
CRU	Central Repair Unit
CTCSS	Continuous Tone Controlled Sub-audible Squelch
CTS	Clear To Send (RS232 flow control signal)
DAC	Digital to Analogue Converter
DC	Direct Current
DCS	Digital Coded Squelch
DMR	Digital Mobile Radio
DSP	Digital Signals Processor
EMC	Electromagnetic Compatibility
EMIF	External Memory InterFace
ESDS Devices	Electrostatic Discharge Sensitive Devices
ETSI	European Telecommunications Standards Institute
FPGA	Field Programmable Gate Array
FPP	Field Personality Programmer
GPIO	General Purpose Input/Output
GPS	Global Positioning System
IB	Isolated Base
IC	Integrated Circuit
IEC	International Electrotechnical Commission
IF	Intermediate Frequency
I/O	Input/Output
IP	Internet Protocol
IS	Isolated Site
LED	Light Emitting Diode
LVDS	Low Voltage Differential Signal
MCP	Master Control Program
MMI	Man Machine Interface
MOSFET	Metal Oxide Semiconductor Field Effect Transistor
NC	Not Connected

## LIST OF ABBREVIATIONS

Abbreviation	Meaning
OMAP	Open Multimedia Applications Platform
PA	Power Amplifier
PABX	Private Automatic Branch Exchange
PC	Personal Computer
PCB	Printed Circuit Board
PLL	Phase Locked Loop
PMIC	Power Management Multi-Channel Integrated Circuit
PMR	Private Mobile Radio
PSU	Power Supply Unit
PTT	Push (Press) To Talk
PWM	Pulse Width Modulation
R&TTE	Radio and Telecommunications Terminal Equipment
RAM	Random Access Memory
RF	Radio Frequency
RSSI	Received Signal Strength Indicator
RTS	Request To Send (RS232 flow control signal)
RX	Receiver
SDB	Simoco Digital Base
SDRAM	Synchronous Dynamic Random Access Memory
SINAD	Signal to Noise plus Distortion
SIP	Session Initiation Protocol
SM	Site Master
SW	SoftWare
TCXO	Temperature Compensated Crystal Oscillator
TX	Transmitter
UHF	Ultra High Frequency
USB	Universal Serial Bus
VAC	Voltage Alternating Current
VAC <sup>(2)</sup>	Virtual Area Controller
VCO	Voltage Controlled Oscillator
VCTCXO	Voltage Controlled Temperature Compensated Crystal Oscillator
VDC	Voltage Direct Current
VHF	Very High Frequency
VM	VAC Master
VoIP	Voice over Internet Protocol
VSWR	Voltage Standing Wave Ratio
WEEE	Waste Electrical and Electronic Equipment

# 1 INTRODUCTION

## 1.1 SIMOCO Xd SDB600 SERIES



**Figure 1. Simoco Xd, SDB600 Series Base Station.**

The SDB670 is a fully integrated Digital Mobile Radio (DMR) base station repeater. Conforming to European Telecommunications Standards Institute (ETSI) open standards, SDB670 combines Simoco's Voice over Internet Protocol (VoIP) technology with advanced digital radio modules.

This IP connected infrastructure platform supports DMR Tier II and Tier III operation as standard with features being enabled via software licensing. Use of Ethernet networks enables the deployment of multi-site radio systems and allows the inclusion of additional features such as Session Initiation Protocol (SIP) Private Automatic Branch Exchange (PABX) interconnection and Dispatcher terminals.

The 2U SDB670 is suitable for 19 inch rack installations and an optional wall mount is available. All variants use a common programming application.

## 1.2 FEATURES

- Compact 2U size.
- Integrated Power Supply.
- Optional rack mountings for desktop or rack-mounted use.
- Easily identifiable indications for Transmit and Receive in both slots.
- Health and alarms are clear-at-a-glance, with further information available via IP management application.
- 100% Duty Cycle at 25 W.
- IP connectivity for applications interface, configuration, monitoring, telephony and trunking support.
- Programmable facilities connector.



## 2 PRODUCT CODES

This section specifies how the DMR equipment will be coded and labelled, and the structure of these codes. The following information is displayed on the Type Approval Label located on the rear panel of the base station.

### 2.1 ORDER CODE

The order code specifies the Transceiver's model and features. The Order Code structure consists of eight fields with 11 alphanumeric characters.

Field 1	Field 2	Field 3	Field 4	Field 5	Field 6	Field 7	Field 8
6	B	1	TU	A1	S	0	00

The fields of the order code are broken down as shown below in **Table 1**.

**Table 1. Order Code Information.**

Field	Description	Range	Example	Explanation
1	Model	0 – Z	6	SDX600 range of products
2	Type	0 – Z	B	Base Station
			K	SDP660 Portable – Keypad version
			M	SDM600 Mobile range
			N	SDP650 Portable – Non-keypad version
3	HW Series	0 – Z	1	Used for major changes in mechanics or hardware builds. 0 = Prototype/Revision 1
4		AC	TU	136 MHz – 174 MHz
		TU		400 MHz – 480 MHz
		UW		440 MHz – 520 MHz
		00		Not Applicable
5	Mechanics	00 - ZZ		Includes chassis/case, endplates, sealing
			00	Prototype
			01	Standard Mobile
			02	Black Portable
			03	Yellow Portable
			04	Red Portable
			05	Blue Portable
			A1	AC – 25 W
			A2	AC – 50 W
			A3	AC – 100 W
			D1	DC – 25 W
			D2	DC – 50 W
			D3	DC – 100 W
6	Market Code	0 – Z		Used by factory Program to select/create appropriate label.
			C	China
			H	Harris <sup>(Note 2)</sup>
			S	Simoco International <sup>(Note 1)</sup>
7	HW Option	0 – Z	0	Specifies Option board fitted. 0 = Standard Radio – No Option Board.
8	Spare	00 – ZZ	00	Reserved for future use.
Note 1. Includes labelling suitable for Australia, Europe, USA, Canada.				
Note 2. Example of support for rebranded radios.				

## 2.2 FACTORY CODE

The Factory Code number is used to uniquely identify the equipment.

This number is generated from the Order Code, Engineering Change Number (ECN)/build version, the date of manufacture, manufacturer code, and a unique four character base 33 sequence number.

The factory code is printed on a label that is fitted to the base station's Control Board, MMI Board and the chassis. The label shall also contain a 3D 'QR' code.

The factory code is also included on the Radio Label.

Fields 1 – 8	Field 9	Field 10	Field 11	Field 12
6B1TUA1S000	0006	1305	7	0001

The fields of the factory code are broken down as shown below in **Table 2**.

**Table 2. Factory Code Information.**

Fields	Description	Range	Example	Explanation
1-8	Order Code		6B1TUA1S000	Refer <b>Section 2.1</b> .
9	ECN/Build Version	0 – Z	0006	Four digit alpha numeric ECN number. Entered via drop-down list in factory programmer.
10	Date of Manufacture	YYWW	1305	Year 2013, Week 5
11	Manufacturer Code	0 – Z	3	ADI
			5	EMMT
			7	Jabil
			8	Tioga
			9	Simoco Derby
12	Serial Number	0001 – ZZZZ	0001	Sequential serial numbers. Base 33 (excludes I, O and U).

## 2.3 RADIO LABEL

The Radio Label shall contain information that uniquely identifies the Transceiver, including a unique Radio Serial Number.

### 2.3.1 Radio and Control Card Serial Number

The Radio and Control Card Serial Numbers are generated from the Factory Code and are created with the following fields:

Field 1	Field 2	Field 3	Field 4	Field 5	Field 6
3	6	M	TU	1305	153T

The fields of the radio serial number are broken down as shown overleaf in **Table 3**.

**Table 3. Radio Serial Number Information.**

Field1	Description	Range	Example	Explanation
1	Manufacturer Code	0 – Z	3	ADI
			5	EMMT
			7	Jabil
			8	Tioga
			9	Simoco Derby
2	Model	0 – Z	6	SDX600 range of products
3	Type	0 – Z	B	Base Station
			C	Control Card
			I	MMI Board
			K	SDP660 Portable – Keypad version
			M	SDM600 Mobile range
4	Frequency Band	E0 AC KM R3 TU UW X8 00	TU	66 MHz – 88 MHz
				136 MHz – 174 MHz
				208 MHz – 245 MHz
				335 MHz – 400 MHz
				400 MHz – 480 MHz
				440 MHz – 520 MHz
				806 MHz – 870 MHz
				Not Applicable
5	Date of Manufacture	YYWW	1305	Year 2013, Week 5
6	Serial Number	0001 – ZZZZ	153T	Sequential serial numbers. Base 33 (excludes I, O and U).

## 2.4 MAC ADDRESS

Each DMR Base is assigned a unique 12-character alphanumeric Media Access Control (MAC) address, which is included on the Radio Label on the rear panel of the DMR Base.

### 3 SPECIFICATIONS

The specifications of the DMR Base Station are detailed in the following paragraphs and tables.

#### 3.1 GENERAL

The General specifications are contained below in **Table 4**.

**Table 4. General Specifications.**

<b>Frequency Bands</b>	AC: 136 MHz – 174 MHz; TU: 400 MHz – 480 MHz; UW <sup>(Note 1)</sup> 440 MHz – 500 MHz
<b>Power Supply</b>	12 VDC or 110/240 VAC
<b>Frequency Stability</b>	± 0.5 ppm
<b>Channel Spacing</b>	12.5 kHz, 25 kHz.
<b>Channel Capacity</b>	2000
<b>Antenna Connect</b>	Tx - 50 Ω female N-type. Rx – BNC.
<b>Type Approval</b>	CE Type approvals to Radio and Telecommunications Terminal Equipment (R&TTE) Directive 1999/05/EC: EN300-086 -2: V1.3 Analogue; EN300-113-1: V1.6.1 Digital; EN301-489-5: V1.3.1 Electromagnetic Compatibility (EMC); IEC60950-1:2005 (2 <sup>nd</sup> Edition) + Am 1:2009 EN60950-1:2006/A12:2011.
<b>Dimensions</b>	89 mm (2U) High x 482 mm Wide x 485 mm Deep (Excluding cables and ears)
<b>Weight</b>	8.95 kg
<b>Environmental:</b>	
<b>Storage Temperature</b>	-40 °C to +80 °C (-40 °F to +176 °F)
<b>Operating Temperature</b>	-30 °C to +55 °C (Full Spec.), (-22 °F to +131 °F)
<b>IP Rating/Humidity</b>	IP30 ingress protection, Humidity <95% non-condensing
Note 1. For future development.	

#### 3.2 TX SPECIFICATIONS

The Transmitter specifications are contained below in **Table 5**.

**Table 5. 25 W Transmitter Specifications.**

<b>Transmit Power</b>	0.5 W to 25 W in steps
<b>Tx Current Consumption</b>	Typical: 25 W: 4.7 A @ 13.6 V (20 °C) Max: 25 W: 4.9 A @ 13.6 V (fans & audio on max)
<b>Modulation Limiting</b>	±2.5 kHz @ 12.5 kHz, ±5.0 kHz @ 25 kHz
<b>FM Hum and Noise</b>	>40 dB (12.5 kHz), 45 dB (25 kHz)
<b>Conducted/ Radiated Emission</b>	Complies with ETS086-1, ASNZS4295, TIA603-B
<b>Adjacent Channel Power</b>	-60 dBc (ETS086-1)
<b>Audio Response</b>	+1/-3 dB (analogue)
<b>Audio Distortion</b>	3% (TIA-603-B)
<b>Digital Vocoder Type</b>	AMBE+2 half rate

### 3.3 RECEIVER

The Receiver specifications are contained below in **Table 6**.

**Table 6. Receiver Specifications.**

<b>Analogue Sensitivity</b>	-117.5 dBm (12 dB SINAD)
<b>Digital Sensitivity</b>	-117.5 dBm (BER 1%)
<b>Rx Current Consumption</b>	0.9 Amps
<b>Intermodulation</b>	70 dB (ETS086-1)
<b>Adjacent Channel Sensitivity</b>	65 dB (ETS086-1)
<b>Spurious Rejection</b>	70 dB (ETS086-1)
<b>Hum and Noise</b>	-40 dB (TIA603-B)
<b>Audio Response</b>	+1/-2 dB (0.3 kHz – 2.55 kHz analogue)
<b>Audio Distortion</b>	3% @ 4 W Analogue Mode
<b>Conducted Spurious Emission</b>	-57 dBm (ETS086-1)

## 4 DESCRIPTION

The SDB670 DMR Base Station is a two Unit (2U) high by 19” wide rack-mountable unit containing two SDM600 sub-assemblies, a control card, a Man-Machine Interface (MMI) card. An integrated Power Supply Unit (PSU) is also fitted in the AC version.

The internal layout of the AC version of the DMR Base Station showing the position of the main sub-assemblies is shown below in **Figure 2**.

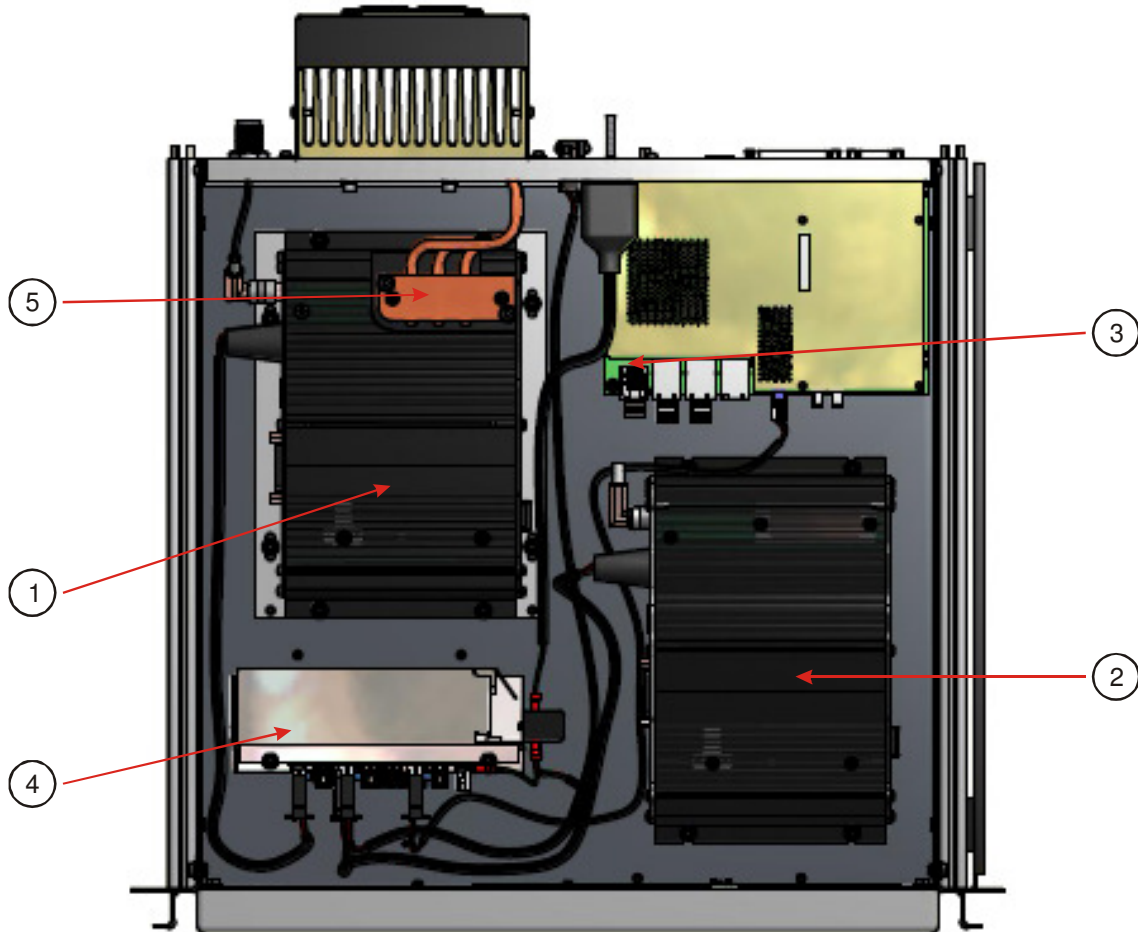

**Figure 2. Internal Layout of DMR Base Station (AC version).**

The internal layout of the DC version of the DMR Base Station is shown overleaf in **Figure 3**.

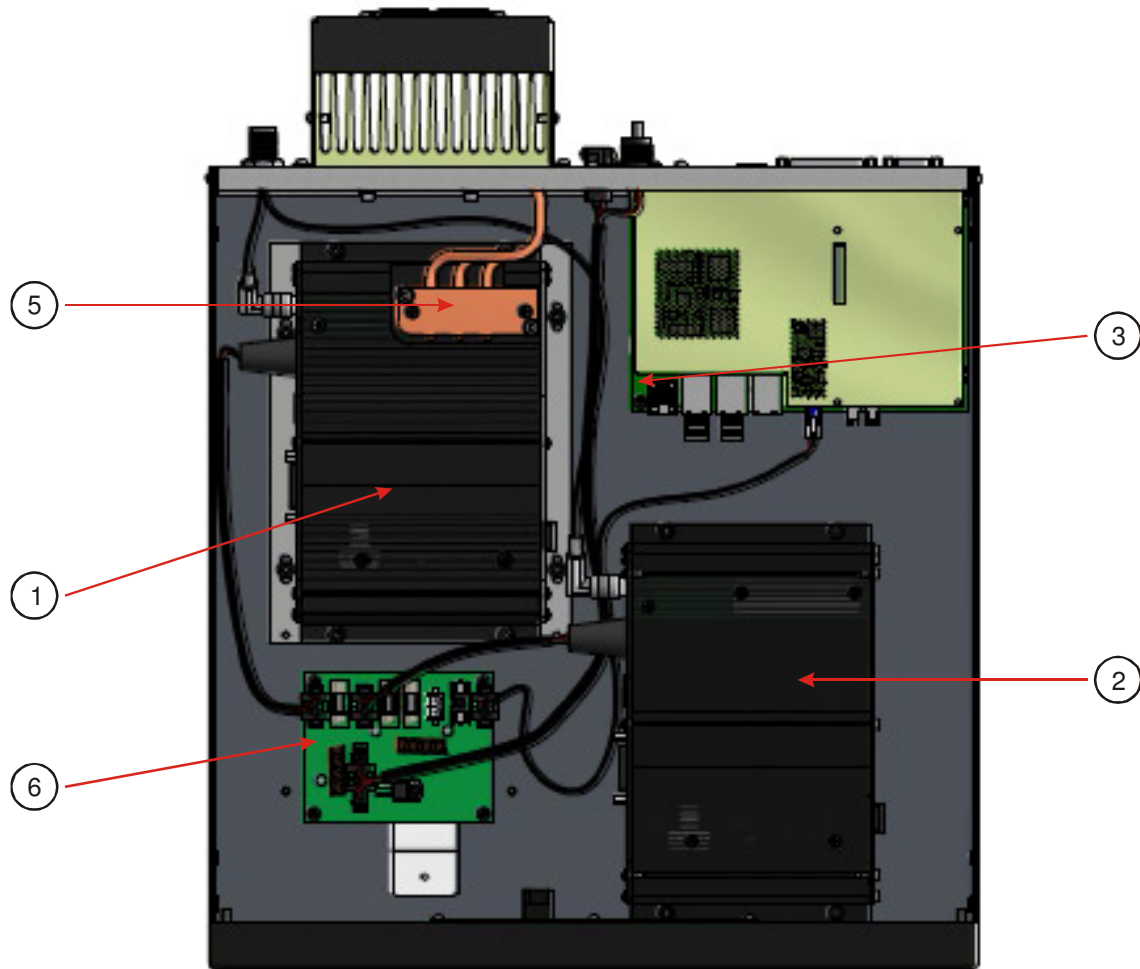

**Figure 3. Internal Layout of DMR Base Station (DC version).**

In **Figures 2** and **3**, the main sub-assemblies are numbered and refer to the following:

1. Tx Engine Assembly.
2. Rx Engine Assembly.
3. Control Board Printed Circuit Board (PCB).
4. PSU Assembly (AC version only).
5. Heat Pipe Assembly.
6. MMI PCB.
7. External Fan.
8. Internal Fan (AC version only).
9. Fuse Board (DC version only).

#### 4.1 SDM600 SUB-ASSEMBLIES

The RF performance of this product is derived from a pair of SDM600 Engine Assembly PCBs mounted on a Heat sink sub-assembly that is designed to permit continuous operation at full power. The sub-assembly also provides RF screening, so it is important that it is accurately assembled and reassembled.

These units are electrically identical to the SDM600 Mobile and are also fully interchangeable in the 25 W power group. Control is provided via the 10-way RJ45 connector. Power is supplied via the power harness connector and RF signals are coupled to the British Naval Connector (BNC) sockets with double-screened cables.

## 4.2 FRONT PANEL

The SDB670 front panel is illustrated below in **Figure 4**.



**Figure 4. SDB670 Front Panel.**

### 4.2.1 LED Indicators

On the front of the SDB670 base station there are 12 Light Emitting Diode (LED) indicators. Their details are explained below in **Table 7**.

**Table 7. Details of Front Panel LED Indicators.**

LED	Legend	Colour	Description
Health	♥	Green	Indicates
Func 1	VM		For Tier II this is a programmable function. For Tier III this indicates the base is a VAC Master
Func 2	SM		For Tier II this is a programmable function. For Tier III this indicates the base is a Site Master.
	~		Indicates base is in Analogue Mode
Rx 1	R1		Indicates signal received on Slot 1
Tx 1	T1		Indicates unit is keyed up and transmitting on Slot 1
Power	⚙		Indicates the presence of electrical supply voltage.
Tx 2	T2	Red	Indicates unit is keyed up and transmitting on Slot 2
Rx 2	R2	Yellow	Indicates signal received on Slot 2
	⏏		Indicates base is in DMR Mode
Func 3	IS	Orange	For Tier II this is a programmable function. For Tier III this indicates the base is an Isolated Site.
Func 4	IB	Orange	For Tier II this is a programmable function. For Tier III this indicates the base is an Isolated Base.
Alarm	⚠	Red	Indicates a pre-arranged alarm condition exists.

## 4.3 REAR PANEL CONNECTORS

The rear panel of the SDM670 DMR base station showing all the external connections for both the AC and DC version are shown overleaf in **Figures 5** and **6**. The functions of each connector on the rear panel are detailed in **Table 8**.



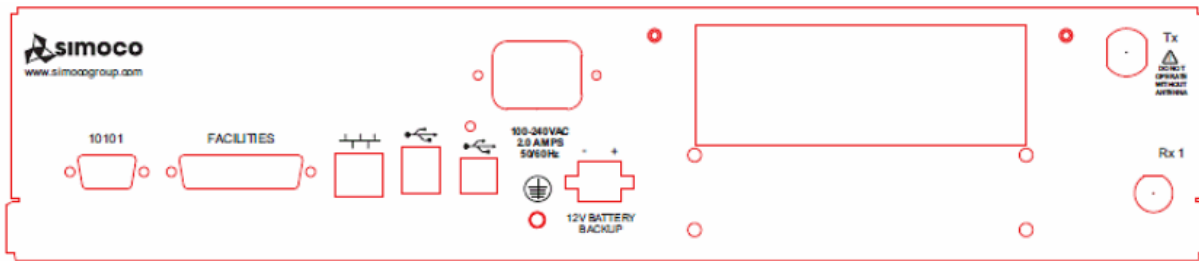

Figure 5. Layout of Rear Panel (AC version).

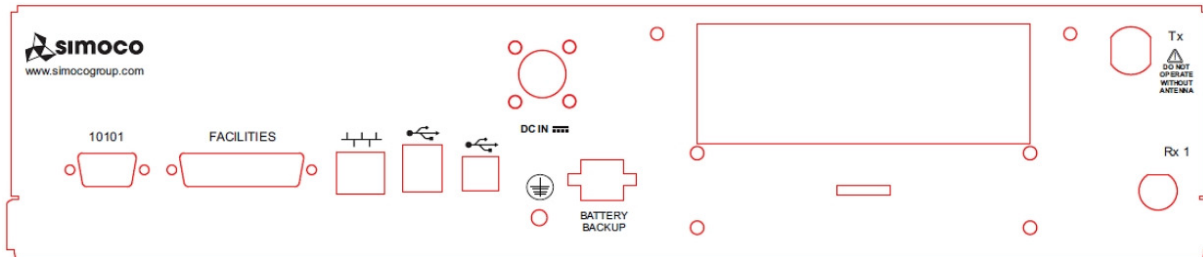

Figure 6. Layout of Rear Panel (DC version).

Table 8. Rear Panel Connections.

Connector #	Conn Type	Function	Description
		Power I/P	13.8 V DC power input
S2	RS232	Serial Port	
S1	D Type	Facilities	
P5	RJ45	Ethernet	10/100 base-T RJ45 Ethernet connector
P4	USB Type B	Peripheral	USB peripheral interface
P3	USB Type A	Host	USB interface
		Battery Backup	
Tx	N Type	Tx O/P	RF Power output from the Tx
Rx 1	BNC	Rx I/P	Rx input for full duplex operation

#### 4.3.1 Tx/Rx Connections

The Tx antenna connection on the DMR Base is provided with 50  $\Omega$  female N-type socket, while for the Rx antenna connection a BNC socket is used.

The Tx antenna cable connection must be made with 50  $\Omega$  N-type on a flexible tail. The Voltage Standing Wave Ratio (VSWR) of Tx and Rx connections should be tested prior to use by using of a suitable test set, e.g. an Anritsu/Wiltron S331A. A good VSWR of 1.5:1 or better at the relevant Tx and Rx frequencies should be ensured.

Mating connectors should be galvanically compatible with nickel outer and gold centre pin to minimise passive intermodulation.

A minimum of 85 dB transmit-receive isolation should be provided by the antenna system and associated filters.

It is recommended that a good quality flexible co-axial cable is used, e.g. with double-screening braid and multi-strand copper inner.

**CAUTION**

The Antenna System must to be protected against lightning by means of an earthing system and surge protection device.

Do not connect Antenna Lightning conductors to the base station or Mains Earth.

### 4.3.2 Power Input Connection

Depending on the variant of DMR Base (DC or AC), the power connection can be either a 2 Pin, DC connector or a standard IEC AC mains socket.

For DC power, a 2-pin IP67 DC plug connector is used. Only two pins are wired to suit the voltage range, see **Table 9** below.

**Table 9. DC Power Connector Pin-outs.**

Pin	Description
1	+13.8 V
2	Ground

For AC power, a standard IEC Mains connector is used (see **Figure 5** below). An appropriate version of power cord, relevant to the area of use, is supplied with the SDB670 DMR base station (see **Section 7**).

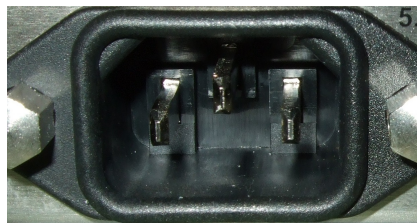

Standard IEC AC Mains Connector



2-pin IP67 DC Connector

**Figure 7. AC and DC power connectors.**

### 4.3.3 Earth Point

On both the AC and DC versions, the earth stud on the rear panel is provided for protective earthing on the equipment. This should be connected using heavy duty earthing wire, with a capacity greater than mains feed to equipment and with as few bends as possible, typically 6 mm Green/Yellow with 5 mm eyelet tag.

### 4.3.4 P4 USB Type B Connector

The Universal Serial Bus (USB) Type B connector is used as the peripheral connection to a PC. The connector pin-outs are detailed below in **Table 10**.

**Table 10. USB Type B Connector Pin-outs.**

Pin	Function
1	Vcc (+5 V)
2	Data -
3	Data +
4	Ground

### 4.3.5 P3 USB A Duel

The USB Type A connector is used as the host connection. The connector pin-outs are detailed below in **Table 11**.

**Table 11. USB Type A Connector Pin-outs.**

Pin	Function
1	Vcc (+5 V)
2	Data -
3	Data +
4	Ground

### 4.3.6 P5 Ethernet

The Ethernet socket is a 10/100 base-T RJ45 connection. The Ethernet socket provides a 10Base Ethernet connection which is used for network connection.

The P5 Ethernet connector uses standard network cable wiring for an RJ45, which is detailed below in **Table 12**.

**Table 12. Ethernet RJ45 Connector Pin-outs.**

Pin	Description
1	Tx Data+, balanced I/P 1
2	Tx Data-, balanced I/P 2
3	Rx Data+, balanced O/P 1
4	NC
5	NC
6	Rx Data-, balanced O/P 2
7	NC
8	NC

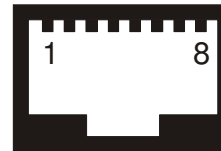

### 4.3.7 S2 Serial Port

The serial connection is a standard DB-9 female RS-232 socket. The connector pin-outs for the 9-way D Type S2 Serial Port are shown below in **Table 13**.

**Table 13. S2 Serial Port Connector Pin-outs.**

Pin	Function
1	Connected to pin 4 and 6
2	Tx 1
3	Rx 1
4	Connected to pin 1 and 6
5	0 V
6	Connected to pin 1 and 4
7	Rx 2 (opt CTS 1)
8	Tx 2 (opt RTS 1)
9	NC

### 4.3.8 Facilities Connector

The 25-way D Type facilities connector can be programmed for any combination of digital inputs and outputs.

The connector pin-outs for the 25-way D Type Facilities Connector are shown below in **Table 14**.

**Table 14. Facilities Connector Pin-outs**

Pin	Function	Pin	Function
1	Digital Input	14	Digital Output
2	Digital Input	15	Digital Output
3	Digital Input	16	Digital Output
4	Digital Input	17	Digital Output
5	Digital Input	18	Digital Output
6	Digital Input	19	Digital Output
7	Digital Input	20	Digital Output
8	Digital Input	21	Digital Output
9	GPS Rx +	22	GPS Rx -
10	GPS Tx +	23	GPS Tx -
11	1PPS Rx +	24	1PPS Rx -
12	Digital to Analogue Convertor (DAC) Output	25	0 V
13	Supply Voltage		

The maximum current provided by the supply voltage pin is 1 A, which is protected by a self resetting fuse.

Digital Outputs are open collector able to sink 300 mA each; the total for all outputs must not exceed 600 mA. See **Figure 8** overleaf.

Digital inputs are active low. Digital high voltages should not exceed 20 V. See **Figure 8**.

GPS Rx and 1PPS Rx are Differential RS422.

The “Analogue Out” signal is between 0 V and 5 V and software controlled to indicate various functions e.g. RSSI.

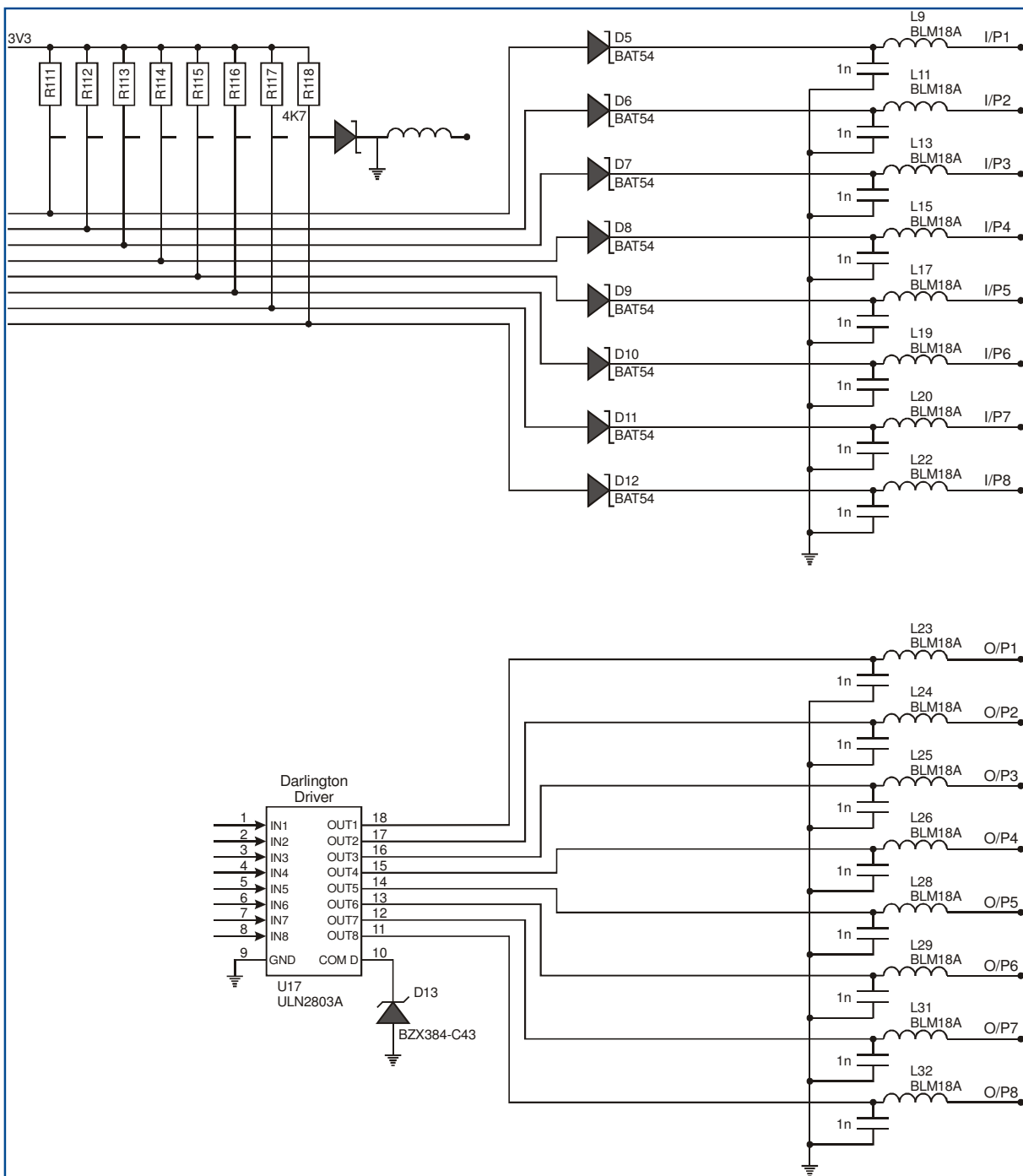

Figure 8. Digital Inputs and Outputs.

### 4.3.9 Battery Backup

The Battery Backup facility uses a two-pin Mate-N-Lok connector.

When the unit is used with a backup battery the following conditions must be met:

1. The Battery must be of a 12 V lead acid type.
2. The capacity of the battery should not exceed 12 Ah.
3. The cable used to connect the Battery to the unit must be capable of carrying 10 A and fused near the battery @ 10A.

## 5 TECHNICAL DESCRIPTION

### 5.1 MMI BOARD

#### 5.1.1 Description

The purpose of the MMI Board is to provide the Man-Machine Interface between the Control Board and the user.

A I2C interface from the control board controls a General Purpose Input Output (GPIO) device. The GPIO device controls 12 LEDs for user diagnostics.

### 5.2 CONTROL BOARD

#### 5.2.1 Circuit Board Layout

The layout of the Control Board PCB is shown in **Figure 9**.

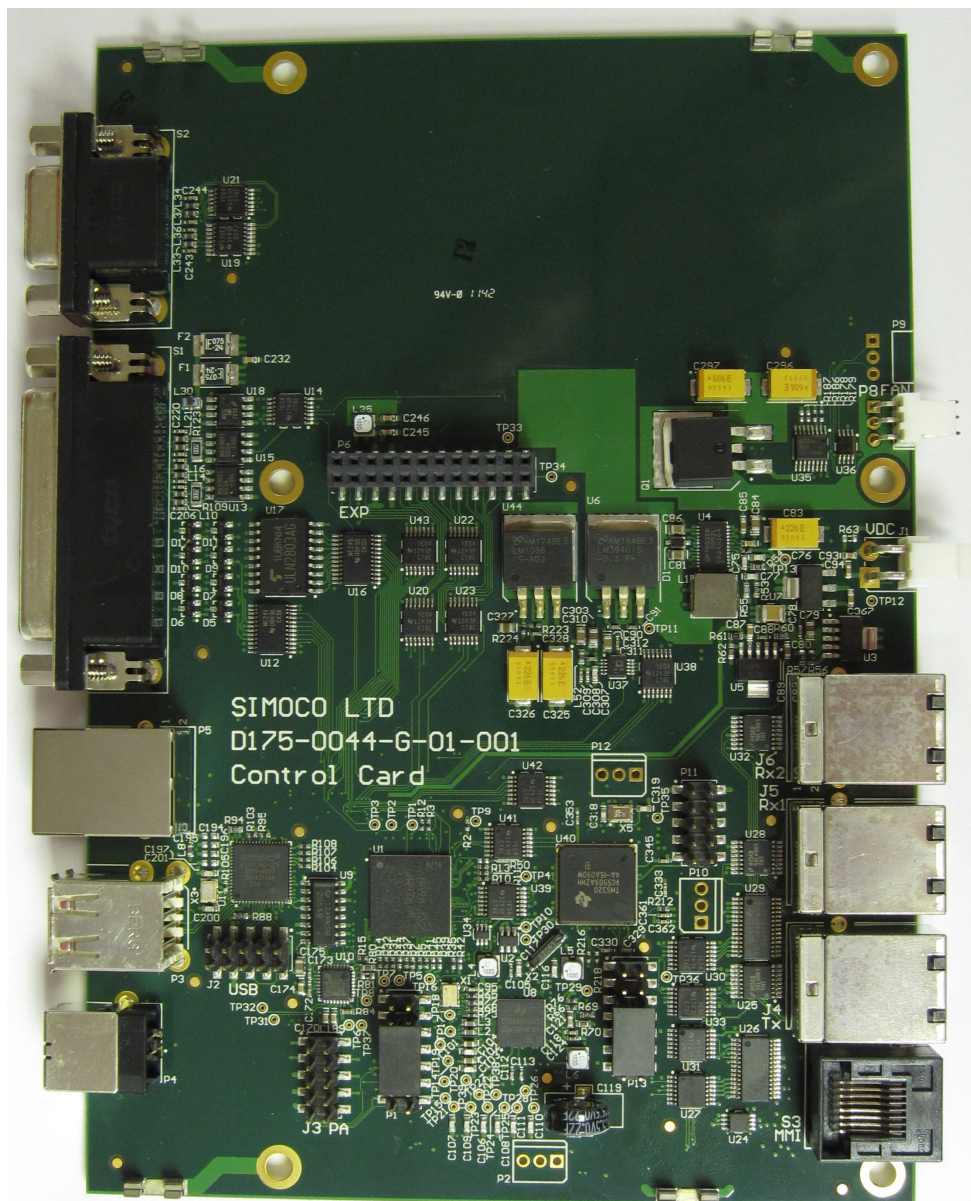

Figure 9. Control Board Layout.

## 5.2.2 Circuit Description

A detailed block diagram of the Control Board is provided in **Appendix A**.

### Power

The control board requires a 12 V nominal supply. A switch mode power supply IC is used to generate the 5 V supply used by the Power Management Multi-Channel Integrated Circuit (PMIC) to supply the power rails of the processor. Linear regulators are provided to reduce the 5 V rail down to provide supply voltages to the Digital Signals Processor (DSP) Co-Processor, Ethernet and USB devices.

### Main Processor

The main processor is a Texas Instruments OMAP DM3725; this is a dual core device containing an ARM Cortex A8 and a C64+ DSP. The Open Multimedia Applications Platform (OMAP) is a package-on-package device where the device providing the flash and Synchronous Dynamic Random Access Memory (SDRAM) is soldered directly to the top of the processor.

### DSP Co-processor

The DSP Co-processor is a Texas Instruments TMS320C5509, which provides the additional DSP processing power.

### Ethernet Interface

A LAN9514 USB Ethernet Hub device provides an Ethernet interface to the OMAP processor. This device is interfaced to an RJ45 socket with built in magnetics.

### Radio Interface

The control card supports the connection of three SDM radio modules, one as a transmitter and two as receivers. These are connected to the OMAP processor via a Low Voltage Differential Signal (LVDS) interface presented on 10 Way RJ45 connectors.

### USB A

A USB Ethernet Hub device provides four USB A connections two of which are presented externally.

### USB B

The PMIC device provides a USB B type interface for connection to a PC.

### Digital I/O

Digital I/O is provided by the OMAP processor to provide digital I/O to the Facilities Connector as well as internal control.

### Fan Control

The OMAP processor performs fan control via a Maxim Fan Controller IC. The speed of the Fan is dependent on the temperature reported by the Tx Radio engine. The fan generates a tachometer output that allows the software to detect a fan failure or potential failure by monitoring fan speed.

### Analogue Outputs

Two analogue outputs are provided by a dual-channel DAC (AD5322). One provides control of the Voltage Controlled Temperature Compensated Crystal Oscillator (VCTCXO) and the other provides an analogue output to the Facilities Connector, for example the Received Signal Strength Indicator (RSSI) level.

## Analogue Inputs

The PMIC provides multiple analogue inputs which are currently used to provide voltage monitoring of the unregulated supply.

## GPS Input

The facilities connector provides an RS422 serial connection with a primary purpose of connecting a GPS receiver to provide an accurate time stamp. An RS422 input is also provided for connection of the 1PPS output from a GPS Rx to provide a very accurate reference clock to tune the internal oscillator.

## External Power

The control card provides the supply voltage at up to 1 A on the facilities connector.

## RS232 Serial Interface (DB9)

The rear of the control card contains a standard 9-way serial connection in order that a straight through cable may be used to provide debug and control data.

## Expansion Header

An expansion header provides the necessary signals to support a multitude of future expansion boards.

## 5.3 TRANSMITTER AND RECEIVER MODULES

### 5.3.1 Control

Refer to **Figure 10** (page 42) and Figures 2 and 3 in TNM-S-E-0005, SDM600 Series – Issue 4 Circuit Diagrams [2].

### DSP and FPGA

The SDM600 transceiver operates under the control of a DSP (U203) and Field Programmable Gate Array (FPGA) (U300) combination that, together with a number of other dedicated devices, perform all the operational and processing functions required by the radio, the software for which is contained in flash memory. The FPGA contains an internal embedded processor core and provides the majority of radio functionality, including demodulation, while the DSP provides most of the complex filter and timing functions, a 57.6 MHz clock to the FPGA and ADC conversion. Both the DSP and FPGA have internal Random Access Memory (RAM) for rapid code execution. In addition, the FPGA utilizes external RAM contained in Cellular RAM U304 for increased capacity.

The FPGA in conjunction with the DSP provides the following functions:

- Channel set-up of all operating frequencies.
- Modulation processing and filtering.
- De-modulation processing and filtering.
- Tx power output.
- Modulation equalisation adjustment.
- Rx front-end tuning.
- Serial communications with Alignment Tool and options including LVDS for microphone and control head.
- Modem functionality for data modulation.
- All DMR/CTCSS/DCS generation and decoding.



- DSP clock dither.
- Rx muting control.
- RSSI/Automatic Gain Control (AGC) control.
- Tx/Rx switching and Press (Push) To Talk (PTT) control.
- Synthesiser Fast-Lock control.
- Phase Locked Loop (PLL) lock detect.
- Rx/Tx Audio switching.
- Power On/Off control.
- Interface functionality with Option Boards and External Devices.
- Battery voltage, reset and Tx current monitor.
- LED status indicators.
- Software upload from Flash.
- Update Flash variables.
- RAM read/write.
- Software security.

### DSP Clock Oscillator

SYN-FCLK1 is routed to DSP U203-F2 via Clock Amplifier Q201 and Clock Spread-Spectrum circuit comprising D205 and associated components. The Clock Spread-Spectrum circuit is incorporated to reduce the coherent 21.4 MHz frequency component by utilizing a spread spectrum technique. This is achieved by driving varactor diode D205 with a noise source derived from an FPGA Pulse Width Modulated (PWM) noise signal. This phase modulates the 21.6 MHz signal with noise so that it covers a wider spectrum, thereby reducing its narrow band power level. The output of the Spread-Spectrum circuit is amplified and squared up by Inverter U208 prior to clocking the DSP.

### Analogue Inputs and Outputs

The FPGA must supply several analogue signals to control the radio including radio tuning and control. It does this with a separate PWM output for each function.

For example, the front-end tune signals (RX-TUNE1 to RX-TUNE4) originate from the FPGA in the form of PWM signals, which are then integrated to provide variable low noise DC voltages. The values for these outputs are stored in flash memory from radio alignment or hard coded into radio software. They are selected depending on the channel that the radio is currently tuned to.

Other analogue PWM derived signals used include Tx power (PA-TXPWR), current limit (PA-ICAL) Rx AGC voltage (RX-AGC), AFC (SYN-AFC1), VCO ALC (SYN-ALCSET), varactor bias (SYN-VARSET), ADC dither (RX-DITHER+/-) and clock spread spectrum (CLK-SS).

Four Analogue to Digital Converters (ADCs) in the DSP, two of which are multiplexed by an Analogue MUX U205, monitor analogue inputs. This provides a total of ten analogue inputs that can be monitored, the main ones being PA-ISENSE, PA-TEMPSENSE, PA-TXMON, BAT-SENSE, VCO-BIAS, LOOP-VOLTS, EXT-SENSE.

### Flash Memory

Flash Memory U204 contains 64 Megabits of storage. It contains all the radio operating software, alignment database, customer configuration and necessary status variables. When power is off, all program software and data are retained in Flash Memory. At power-on, a boot program

downloads the DSP and FPGA software from Flash Memory to their internal RAMs for faster program execution and access to data. All software, except for the customer configuration, is loaded by the factory into the Flash Memory and can be updated via the SDM600/SDP600 Code Loader connected to external interface connector S3. DSP software comprises Boot code and Application code, while FPGA code comprises FPGA code and MCP code. High-level software comprising Operational Code and Customer Configuration is loaded at distribution centres and is loaded via the SDM600/SDP600 Field Personality Programmer (FPP).

### 5.3.2 Receiver

Refer to **Figure 10** (page 42) and Figures 7 and 11 in TNM-S-E-0005, SDM600 Series – Issue 4 Circuit Diagrams [2].

#### Front End Filters and RF Amplifier

The Rx input signal from the antenna passes through the harmonic filter and antenna switch. With the mobile in receive mode, diodes D500, D5502 and D503 in the antenna switch are reverse biased allowing the Rx input signal to be coupled through to the Rx front-end with minimal loss. The overall insertion loss of the harmonic filter and switch is approximately 0.8 dB.

A noise blanker is also fitted to E0 band radios. The noise blanker samples the received signal and gates the 45 MHz signal in the Intermediate Frequency (IF) stage in the event that high level noise transients are received. Due to inherent time delays in the bandpass filters prior to the blanking gate, gating synchronisation occurs before the transients can adversely affect the following stages.

Varactor-tuned bandpass filters at the input and output of the RF amplifier provide Rx front-end selectivity. Varactor tuning voltages are derived from the alignment data stored in the radio. The DSP processes this data to optimise front end tuning relative to the programmed channel frequencies, which may be changed at any time without re-aligning the radio.

To achieve the required varactor tuning range, an arrangement of positive and negative bias power supplies is used to provide a total bias across the varactors of up to 14.0 VDC. A fixed 1.6 V positive bias derived from the 3.2 V supply and voltage divider R438/R439 is applied to the cathodes of the varactor diodes. The negative bias supplies are derived from –12 V and controlled by the FPGA, which outputs PWM for the four front-end tuning voltages RX-TUNE1 to 4, for the particular channel frequency selected. The PWM signal is dependent on channel frequency and tuning and passes through level shifting transistors Q403 to Q410 where it is converted to a negative voltage in the range –0.5 V to –11.5 V. The –12 V rail of the level translators is generated by U908A/B/F with D912 to D915 providing the required voltage multiplication.

The RF amplifier stage comprises a low noise transistor amplifier Q402, which is compensated to maintain good linearity and low noise matching, and Q400/Q401 provide it with a constant current source. This provides excellent intermodulation and blocking performance across the full operating range. The overall gain of the front-end is typically 14 dB for all bands. D412 provides protection for Q402 from high level signals.

#### Mixer and IF Section

The output of the last front-end bandpass filter is coupled into a double balanced mixer comprising T471/D470/T472, which converts the RF signal to an IF frequency of 45 MHz. The local oscillator injection level from the Voltage Controlled Oscillator (VCO) is typically +7 dBm at TP414 with low side injection used for UHF bands and high side for frequency bands less than 400 MHz.

Following the mixer is crystal filter Z400, its matching networks and IF amplifier Q419. The IF amplifier provides approximately 20 dB of gain, and drives an AGC circuit comprising D413/D414. The purpose of the AGC circuit is to linearise the Rx gain across the band as well as limiting very high level signals that could reduce the Rx performance. The AGC is set via RX-AGC during radio alignment and is controlled via a PWM output from the FPGA. The gain of Q419 can also be

reduced by approximately 20 dB in a single step when D415/D416 are turned on by the FPGA via RX-GAIN.

The output of the AGC circuit contains a matching network for the following crystal filter Z401, which in turn is matched to a dual current amplifier U402. The crystal filters provide part of the required selectivity for rejection of close in unwanted signals.

The current amplifier provides an unbalanced to balanced conversion as well as providing a low source impedance suitable for driving the following DAC U401. The filter comprising L485a/L486a and associated components provides correct matching to the IF ADC.

### IF Analogue to Digital Convertor

The 45 MHz balanced output from the IF stages is fed to U401 pins 1 and 2 where it is directly clocked in via a 21.6 MHz clock at pin 9. This converts the 45 MHz analogue signal to 12 bit digital outputs ADC-0 to ADC-D11. In addition, dither inputs are also provided in parallel with the IF input via shaping filter L490/L491 and associated components. The dither inputs are derived from the FPGA as 48 kHz triangular waveforms at a level such that improved resolution of the least significant ADC bit can be obtained, effectively resulting in a reduction of at least 40 dB to the measured noise floor, thereby enabling the measurement of a much lower level of IF signal. Suitable high frequency roll-off is provided on all the digital outputs to minimize noise. In addition, a 1.5 V reference voltage is derived from U401-31 which is used for biasing its analogue inputs and also to provide low impedance current limited source voltages 1V5-S and 1V5-REF via U400.

The 12 bit digital outputs running at a 21.6 MHz sample rate are fed to the FPGA U300 where they are processed to form I/Q quadrature signals running at a 96 kHz sample rate. This is then fed through a series of digital filters to provide the final stage of adjacent channel filtering, after which it is fed to the DSP U203 via the EMIF bus.

### 5.3.3 Transmitter

Refer to **Figure 10** (page 42) and Figures 8 and 12 in TNM-S-E-0005, SDM600 Series – Issue 4 Circuit Diagrams [2].

#### Drivers and PA Stages

The VCO provides approximately 7 dBm output that is switched to the Tx Buffers via T/R switch comprising D700 and D701. Tx buffers Q501 and Q502 increase the VCO level to provide approximately 17 dBm of drive power to the Tx driver Q500. The Tx driver stage then typically provides 16 dBm of drive to the PA module. Inter-stage attenuator networks are provided between all amplifier stages to provide a high degree of isolation of the VCO from the Tx output.

PA module U505 utilises three Metal Oxide Semiconductor Field Effect Transistor (MOSFET) stages (UHF) and two MOSFET stages (VHF) to achieve the required RF output power up to a level of +44 dBm (25 Watts).

The gain of the PA module is controlled by the power control loop to ensure that Tx output power remains within defined limits over supply voltage and temperature extremes.

#### Note.

***Care should be taken during servicing for low output power. If the drive power is lost, the power control voltage will go high, which may cause the current or power into the PA to exceed its specification. Therefore, the power supply current should be monitored at all times and preset to as low as required. The radio has additional inbuilt safeguards, but these should not be relied on.***

## Power Control

Output power is stabilised by a power control feedback loop. A printed circuit transmission line, L521, R557, C557, D506 and associated components comprise the power detector. Comparator U502A and associated components provide the power setting and control functions. Forward and reverse power is sampled by the power detector and applied as a DC voltage to the inverting input of the comparator.

Power output settings are derived from alignment data stored in flash memory during the initial factory alignment. The DSP processes this data to extrapolate the power output level relative to any programmed channel frequency. The PA-TXPWR voltage is read from the flash and outputted from the FPGA as a PWM signal. This is integrated by a low pass filter comprising R81k and C43k. Further low pass filtering is provided through the buffer stage U502B. The Tx power set voltage at U502B-7 is a DC voltage proportional to the programmed Tx power setting and is applied to the non-inverting input of the comparator U502A.

The resulting output from U502A is a voltage that corrects for output power variations and also set to the required programmed level. This is applied to the power module U505-2 and controls the internal gate bias level on each stage.

PA module output level changes due to supply voltage, load or temperature variations, are detected and applied to the comparator. This proportionally adjusts the PA module bias supply to compensate for these variations.

High temperature protection is provided by thermistor R590, which progressively reduces the power level if the PA module temperature becomes excessive.

PA current is monitored via comparator U500A, which checks the voltage drop across L500/L501/L502 and compares this to its pre-programmed alignment setting PA-ICAL. If this is exceeded, PA-ISENSE will increase, thereby causing the Tx output power to be proportionally reduced via the PA-TXPWR voltage until the current is below the aligned setting.

### Note.

***Care should be taken during servicing for low output power. If the drive power is lost, the power control voltage will go high, thereby possibly causing the current or DC power into the PA to exceed its specification. Therefore, the power supply current should be monitored at all times and preset to as low as required. The radio has additional inbuilt safeguards, but these should not be relied on.***

## Antenna Switch and Harmonic Filter

The antenna switch circuit consisting of pin diodes D500/D502/D503, is controlled by Q504/Q508/Q509 and associated circuitry via PA-ON1. This allows the Tx output to be coupled to the antenna while providing isolation for the Rx input and vice versa. PA-ON1 goes high with the Tx switched on, so that all diodes are forward biased allowing power to be coupled through to the antenna and isolating the Rx by RF grounding its input at C542. The short circuit at the Rx input is transformed to an effective open circuit at D500 by L528, which minimises Tx loading. With the Tx switched off, PA-ON1 goes low so that the diodes are reverse biased allowing the Rx input signal to reach the Rx front end with minimal loss. The harmonic rejection low pass filter comprises L513/L514/L515 and associated capacitors and this is designed to give maximum rejection at approximately twice the maximum carrier frequency. The sharp cut-off characteristic is aided by resonant notch capacitors C576, C577 and C580.

## Temperature Sensor

A temperature sensor U503 has been provided to accurately measure the internal PCB temperature in the vicinity of the Tx PA module. This temperature is automatically read by the

Alignment Tool to measure the actual operating temperature and can also be used for advanced control functions.

### 5.3.4 Frequency Synthesiser

#### General

Refer to **Figure 10** (page 42) and Figures 9, 10, 13 and 14 in TNM-S-E-0005, SDM600 Series – Issue 4 Circuit Diagrams [2].

The frequency synthesiser consists of one VCO each for the Tx and Rx, loop filter, varactor negative bias generator, reference oscillator, a dual PLL U701, VCO buffers and PLL feedback buffer.

#### Fractional PLL

The Fractional PLL device contains two prescalers, programmable dividers and phase comparators to provide a main and auxiliary PLL. The main PLL of U701 controls the frequency of the Tx/Rx VCOs via Charge Pump output CPRF at pin 1 via the Loop Filter. This voltage is set to a nominal 1.6 V that provides a suitable operating point for the VCO varactor diodes. This voltage will be maintained for any frequency but may vary slightly with temperature. VCO feedback to pin 4 is provided via Feedback Buffer Q710 and associated circuitry. The auxiliary PLL is not used in this application. The PLL operation involves the division of the 95.04 MHz reference frequency to a preset comparator frequency of 1760 kHz (Rfr1=54) or 1728 kHz (Rfr2=55) by internal dividers. The VCO frequency is sampled and divided down to the same comparison frequency after which it is phase compared to the comparator reference. The fractional feature of this PLL enables very fine increments of the channel frequency such that any customer requirement can be fulfilled. Any error produces an offset to the Charge Pump output voltage, which is then used to correct the VCO frequency. A valid lock detect output is derived from PLL pin 12 and is sampled by the FPGA. During transmit, if an unlocked signal is detected, the radio will switch back to receive mode. An unlocked signal in receive mode will cause the radio to beep. The Feedback Buffer circuit is provided in the feedback path to provide VCO isolation and correct input level to the PLL.

#### Negative Bias Generator and Loop Filter

A negative varactor bias supply similar to the front-end varactor arrangement has been used to achieve the required broadband tuning range of the VCOs. This voltage is filtered by R706 and C717 to provide a very clean output to the VCOs and it can vary between  $-0.5$  V and  $-16$  V. It is controlled by SYN-VARSET and is derived from another PWM output from the FPGA. This voltage is translated to a negative voltage by the circuit comprising Q701 to Q704. The resulting low noise voltage VAR-BIAS is applied to the anode side of the VCO varactor tuning diodes as a negative bias voltage. The  $-16$  V rail of this supply is generated by U908A/B/F with D912 to D915 providing the voltage multiplication needed to achieve  $-16$  V.

The Loop Filter, comprising R719, R719b, R721, C722 to C725a, C731d and C732, is placed in series with CPP-RF and U701-1 and connected to VAR-BIAS as its reference. The purpose of the Loop Filter is to remove Charge Pump reference components and other PLL generated noise. However, this requirement conflicts with the extremely fast switching times required for DMR operation. As a result, a quad analogue gate U700 has been added. This switches in fast time constant values across the Loop Filter components to rapidly stabilise the CPP-RF output prior to transmission or reception. Timing for these gates is controlled by the FPGA via SYN-FAST1 and SYN-FAST2.

#### Reference Oscillator

Temperature Controlled Crystal Oscillator (TCXO) U702 determines the overall frequency stability and frequency setting of the radio. The frequency setting is achieved by adjusting its ADJ voltage SYN-AFC1 with the Alignment Tool. In addition, the ADJ input can be used in a frequency control loop with the demodulated I and Q signals to provide Rx Automatic Frequency Control (AFC).

U702 operates at 21.6 MHz and is specified at  $\pm 0.5$  ppm frequency stability over the temperature range  $-30$  °C to  $+85$  °C. Its output drives Clock Synthesiser U720 to provide two digital 21.6 MHz outputs and a 95.04 MHz output. The 95.04 MHz output is used as the reference frequency for the PLL as described above. The 21.6 MHz output SYN-ACLK is used as the clock for the Rx ADC U401 and the other 21.6 MHz output SYN-DCLK1 goes via Schmitt Trigger U307 to provide SYN-FCLK1 to clock the FPGA and also the DSP.

### VCO's

The Tx and Rx VCO's use low noise transistors Q602 (Rx), Q604 (Tx) and associated parts to generate the signals for the required band coverage. Electronic tuning is provided by varactor diodes D604 to D615 where fitted with their control voltage CPP-RF derived from the Loop Filter and PLL. A Negative Bias Generator is used to apply an adjustable negative bias to the varactor anodes to extend their tuning range. VCO switching and timing is controlled by the DSP/FPGA via the 5V-RX and 5V-TX power supplies and applied through switches Q607 (Rx) and Q608 (Tx). VCO buffer Q605/Q606 isolates the VCO from load variations in following circuits and active power supply filter Q600 minimises supply related noise. A PLL feedback signal is sampled from the VCO buffer output via buffer Q710. The output from the VCO Buffers is passed through Tx/Rx switch D700/D701, which switches it between either to the Mixer input or Tx Buffer. This switch is controlled by the 5V-RX supply.

In addition, each VCO includes an RF negative feedback network (ALC) to set their operation levels for optimum noise reduction. This is achieved via diodes D616 to D619 that rectify the RF signal. This is filtered and applied to input pins on op-amp U600, which provides amplified correction voltages to the base bias of Q602 and Q604. This circuit also contains a means of presetting and monitoring of the operating current via VCO-BIAS and SYN-ALCSET. The SYN-ALCSET value is factory preset and stored in Flash.

### 5.3.5 Audio Processing

Refer to **Figure 10** (page 42) and Figure 5 in TNM-S-E-0005, SDM600 Series – Issue 4 Circuit Diagrams [2].

#### Receiver Audio

The baseband quadrature signal sent to the DSP U203 is converted into a single digital data input CD-DIN to the Coder-Decoder (CODEC) U803, which in turn converts it into an analogue signal after further processing.

All Rx audio processing and filtering functions are performed by the CODEC under the control of the DSP. These include de-emphasis, mute noise processing, mute control and volume control for narrow and wideband operation. A CODEC DAC then converts the fully processed signal to an analogue audio signal. Independent processing can be achieved on four separate outputs C-OUT1, C-OUT2, C-OUT3 and C-OUT4, which enables great flexibility to suit customer requirements. C-OUT3 normally provides volume controlled, de-emphasised audio to the audio PA U808 via differential amplifier U804A. With a normal radio FPP configuration, the maximum sinusoidal output is limited to  $4 V_{RMS}$  across the  $4 \Omega$  speaker. However, when more power is required, it is possible to achieve up to 16 W into a suitable  $4 \Omega$  speaker.

In addition to the CODEC mute control, the audio PA is also muted on and off via inverter Q800 and CD-SPKRON derived from the FPGA. The other CODEC outputs C-OUT2, C-OUT3 and C-OUT4 can provide any combination of audio characteristics including muted, unmuted, de-emphasised, flat and volume dependency.

All CODEC outputs are fed to analogue gate U806 via differential amplifiers U804 and U805. This enables switching flexibility to the radio connectors S1-4 (LINE-OUT1), S3-1 (LINE-OUT3) and S5-18 (LINE-OUT2).

U805A and U805B are set up as differential constant current amplifiers with 600  $\Omega$  source impedances. U804A and U804B are differential voltage amplifiers with LINE-OUT source impedances of approximately 600  $\Omega$  and 40  $\Omega$  respectively.

An optional CODEC U800 can be provided to provide more complex functionality but is normally not fitted.

### Transmitter Audio

The microphone audio input signal is applied to the microphone input at S1-8 and is derived from an external microphone unit with an applied nominal level of 40 mV<sub>RMS</sub>. This is then routed to CODEC U803-35 as MIC-AUDIO where it is limited to approximately 800 mV<sub>p-p</sub> by D801. Microphone bias, if required, is derived from U803-36, which can apply a pre-programmed bias voltage to the microphone.

Alternate modulation inputs from connectors S3-4 (LINE-IN2), S5-19 (LINE-IN4), S5-14 (LINE-IN5) can also be provided.

CODEC U803 provides input switching of the audio paths after which they are fed to one of two CODEC ADCs. The output of these is routed to the DSP via CD-OUT. All pre-emphasis, filtering, compression and limiting processes for narrow and wideband operation are carried out in the DSP. This processed Tx audio/data is then fed to a Modulation Equaliser that takes equalisation values stored in flash after radio alignment. It applies these values to the Tx data and then directly programs these into PLL U701 via its SYN-PLL-DATA/CLK/STB bus as new frequency data values resulting in frequency modulation of the VCO. The purpose of the Modulation Equaliser is to correct for frequency response variations caused by the VCO loop filter resulting in a flat frequency response from 0 Hz up to the maximum modulation frequency.

### 5.3.6 Power Supplies

Refer to **Figure 10** (page 42) and Figures 4 and 6 in TNM-S-E-0005, SDM600 Series – Issue 4 Circuit Diagrams [2].

### Power On/Off Function

The radio ON/OFF function can be achieved in two ways as follows:

- (a). Analogue control via Q902, Q922 and Q901. In this case a momentary low voltage pulse from the control unit or microphone handset PWR ON button briefly turns on Q902/Q922/Q901. In this time, the radio powers up and the DSP samples the PWR\_DET line after Boot Code has loaded. If this is high, it writes this status to flash, sets PWR-INH low and gets the FPGA to set its PWR-OFF line high. This latches the radio on and the radio remains powered up. If the DSP sees that the PWR-DET is low, it will check the ON/OFF status in flash. If this corresponds to OFF, the DSP will power down the radio by setting PWR-INH high. If the ON/OFF flash status corresponds to ON, the DSP sets PWR-INH low. The FPGA will also read the ON/OFF flash status and will set its PWR-OFF line high so that the radio will remain on.

The Power-off operation requires the ON/OFF button to be pressed for more than 2 seconds. If the ON/OFF button is sensed going low for approximately two seconds by the DSP via the PWR\_DET line, the DSP will save radio settings to flash including the OFF status. It will then set the PWR-INH line high, thereby turning Q901 and hence the radio off.

- (b). Digital control via an external device. This is necessary when multiple devices are connected. It enables the radio to determine which devices are connected and which one has master control. When the ON/OFF button is pressed on any device, the radio will turn everything on as described above and a microprocessor in any external device will note this and send a serial ID message to the radio. After everything has been turned on, pressing the ON/OFF button on the master will send a serial command to the radio to turn everything

off by setting PWR-INH high. The radio also has the ability to power off all external devices whilst remaining on via an FPGA software command at ACCESS-EN.

### Radio Power Supplies

The unregulated 13.8 V DC input (BAT-UNSW) is routed directly to all high current devices and also to the Main Power Switch Q901 provide BAT\_SW supply for all other circuits. BAT-UNSW is used to power the Tx PA U505, the Audio PA U808 and Ripple Filter Q1 and associated parts. The output from Q901 feeds two dual switch-mode regulators U905A/B and U906A/B, which provide 5.0 V, 8.0 V, 3.2 V and 1.2 V outputs respectively at high efficiency. Various protection circuits have been included as follows:

- F1 and F905 are resettable fuses protecting against excess current to accessories and radio.
- U902 and U903 protect digital circuits from over-voltage transients.
- D24 and U10 in conjunction with associated parts protect radio circuits from external transients applied to the radio.
- D1, D2, D3, D4, D5, D6, D8, D22, D23, D29 and D30 protect analogue circuits from over-voltage transients.

The following is a list of the radio power supplies and the main devices and circuits they supply.

#### 8 V Regulator U905B

Regulated 8VVCO supply:

- Tx and Rx VCO's via active filter Q600.

#### 5 V Regulator U905A

Regulated 5VS supply:

- 5V-RX analogue supply via Q915 to Rx front-end, IF Amplifier, T/R switch, Loop Filter.
- 5V-TX analogue supply via Q918 to Tx buffers, VCO switch.
- 5V-RF analogue supply to U400, U500, U502, U700, VCO buffers, VCO Varactor Reference Supply, TCXO.
- 5VD digital supply via L915 to U11, U12, Q800.
- 5VA analogue supply via L915 and L919 to audio circuits including U804, U805, U806.
- 3V2A low noise regulated supply via U910 to U401, U503, U701, U719, U803 via L801, RX-TUNE controls and varactor bias.
- Various switching functions.

#### 3.2 V Regulator U906A

Regulated 3.2 V supply (3V2S):

- 3V2AD reference supply via L931A to ADC U401.
- 3V2D digital supply via L931 to U201, U202, U203, U204, U205, U208, U300, U302, U307.
- 1V8 digital supply via regulator U911 to CODEC U803, Cellular RAM U304 and FPGA U300D.
- 2V5D digital supply via regulator U909 and L929 to FPGA U300C.



- 2V5A analogue supply via regulator U909 and L929a to U804, U805 as a reference supply.

#### 1.2 V Regulator U906B

Regulated 1.2V supply (1V2S):

- 1V2D digital supply via L928/L928a to DSP core U203.
- 1V2 digital supply via L928b/L928c to FPGA core U300C and ADC U401.

#### 3V0 Regulator U310

- 3 V supply (3V0) reference for external interface transient protection.
- –12 V supply (–12V) for front-end varactor tuning.

#### –12/-16 V Power Supply U908A/B/F

- –16 V supply (–16V) for VCO varactor tuning reference.
- –12 V supply (–12V) for front-end varactor tuning.

#### Unregulated 13.8 V (BAT-UNSW)

- Supplies BAT-UNSW to Tx PA module U505.
- Supplies BAT-UNSW to Antenna changeover switch Q504/Q508/Q509.
- Supplies BAT-UNSW to Ripple Filter via R37.
- Supplies BAT-UNSWF to Rx audio PA U808 via L3, L3A, F900.

#### Unregulated 12 V (BAT-SWF)

Supplies BAT-SWF to external accessories via ripple filter Q901. The ripple filter is designed to isolate external accessories from the effects of vehicle-induced ripple on the battery supply.

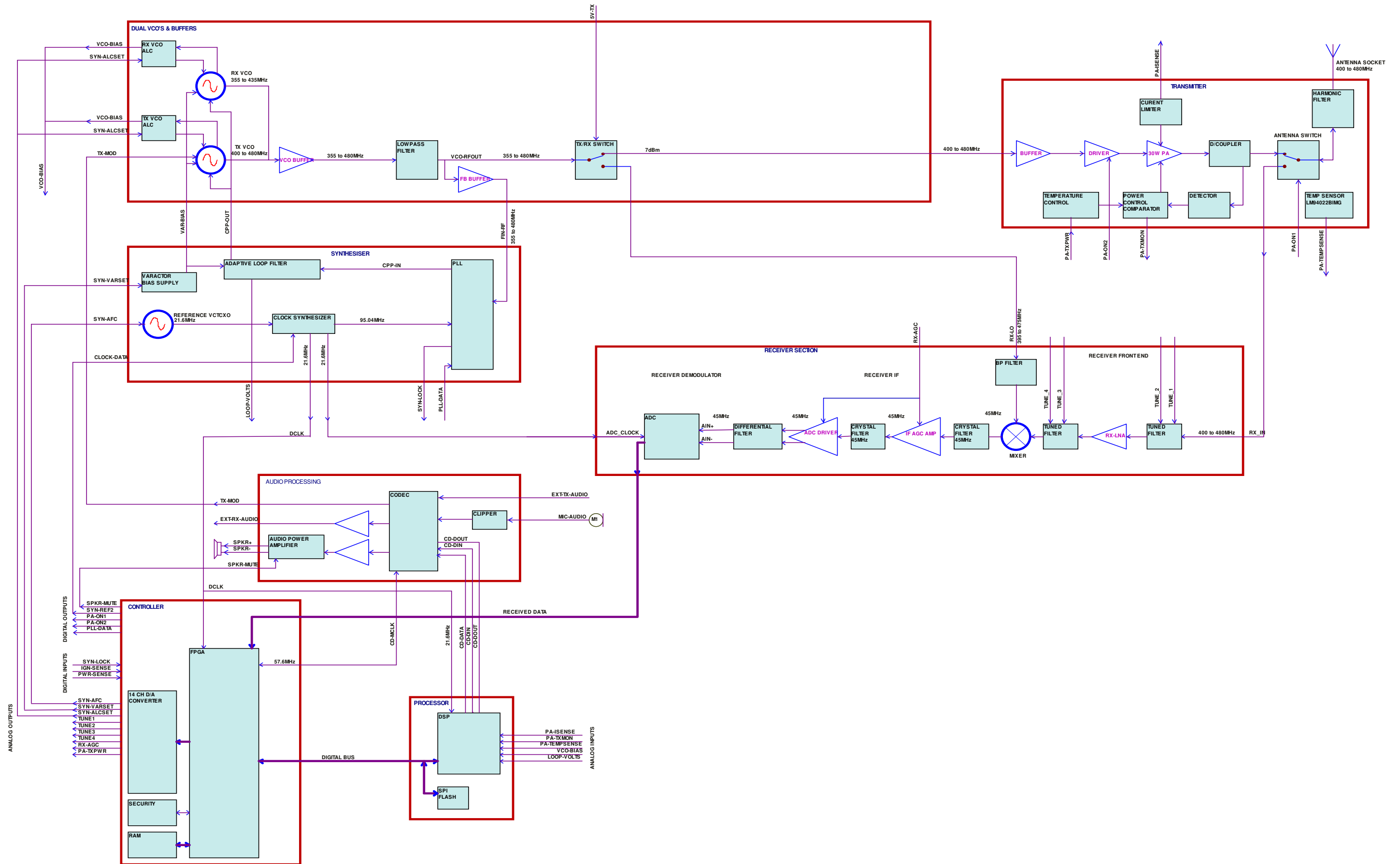

Figure 10. Tx and Rx Modules – VHF/UHF Block Diagram.

## 6 MAINTENANCE

Although no routine scheduled maintenance is required on the DMR Base Station, it is generally good practice to clean the inside of the equipment on each occasion that it is necessary to open it.

Dust and light debris may accumulate in the area of the Fans, Heatsinks and Vents.

Use a fine bristle brush to remove the dust/debris from these areas, taking care not to damage the equipment.

### 6.1 TORQUE SETTINGS

	<p style="text-align: center;"><b>CAUTION</b></p> <p><b>EQUIPMENT DAMAGE.</b> During assembly operations, the Torque settings must be adhered to or damage to the equipment may result.</p>
---	---

The torque settings to be used on the various fixings within the SDB670 Base Station are as follows:

- Heat Pipe Assembly and Heatsink fixings – 1.5 Nm.
- Tx Assembly, M3 x 12 mm Torq Pan Hd Screw – 1.5 Nm.

### 6.2 DISASSEMBLY

When disassembling any part of the DMR base station, take care to note where cables are connected to and where parts belong.

#### 6.2.1 To Remove the Base from a Rack

1. Switch off the equipment.
2. Undo the screws securing the SDB670 to the rack.
3. If the SDB670 base station is to be removed entirely, disconnect all the cables from the rear of the equipment.
4. The SDB670 can now be lifted away from the shelf support or the slide runners if fitted.

#### 6.2.2 To Open the SDB670

1. On the sides of the SDB670, remove the four (two per side) M3 x 6 mm screws.
2. Lift and pull the lid to remove it.

#### 6.2.3 To Remove the Tx Assembly

1. Remove the lid and open the SDB670 as detailed in **Section 6.2.2**.
2. On the Heat Pipe Array, release the four M4 x 20 mm socket cap head screws that secure the array to the 50 W Fan/Heat Sink Assembly.
3. On the Fuse Board, disconnect the Tx Assembly power cable from socket 'S1'.
4. On the Tx Assembly, referring to **Figure 11** below, carry out the following:

- 4.1. Disconnect the Tx RF cable from the BNC socket.
- 4.2. Disconnect the Tx Engine to Control Board cable from the RJ45 connector.
- 4.3. Release the four M4 hexagonal nuts that secure the Tx Assembly to the Tx Engine Adjustment Chassis.
5. The Tx Assembly can now be removed from the unit.

**Note.**

***Care should be taken to support the Heat Pipe Assembly during assembly and disassembly operations.***

6. To remove the heat pipe array from the Tx Assembly, remove the two M4 x 16 mm socket cap head screws and the two M3 x 25 mm Pan Head screws that secure the array to the Tx Assembly.

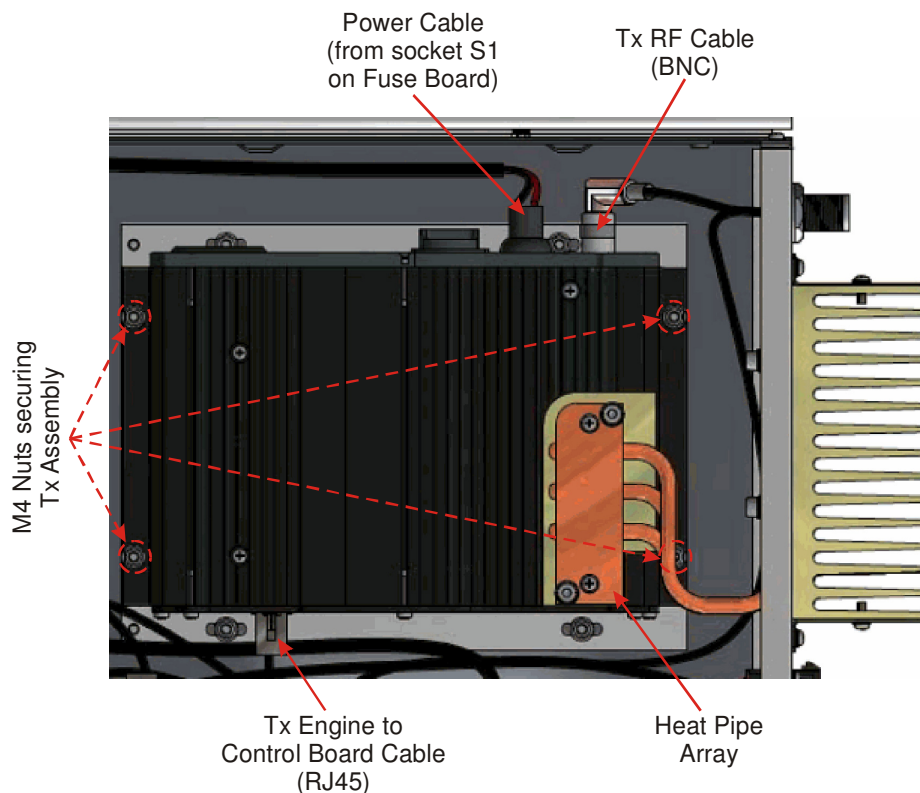
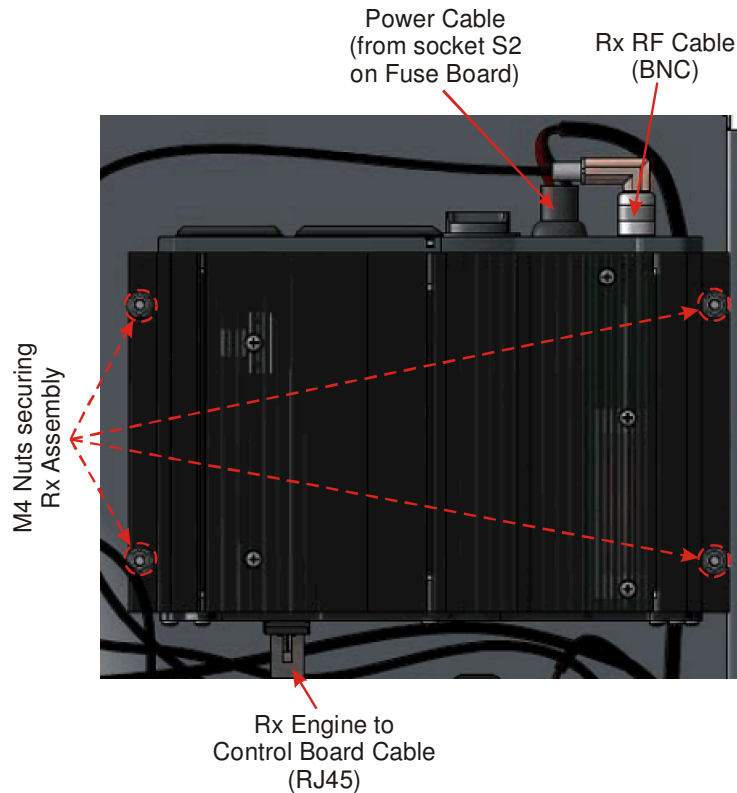

**Figure 11. Removal of Tx Assembly.**

### 6.2.4 To Remove the Rx Assembly

1. Remove the lid and open the SDB670 as detailed in **Section 5.2.2**.
2. On the Fuse Board, disconnect the Rx Assembly power cable from socket 'S2'.
3. On the Rx Assembly, referring to **Figure 12** overleaf, carry out the following:
  - 3.1. Disconnect the Rx RF cable from the BNC socket.
  - 3.2. Disconnect the Rx Engine to Control Board cable from the RJ45 connector.
  - 3.3. Release the four M4 hexagonal nuts that secure the Rx Assembly to the chassis.

4. The Rx Assembly can now be removed from the unit.



**Figure 12. Removal of Rx Assembly.**

### 6.2.5 To Remove the Control Board

1. Remove the lid and open the SDB670 as detailed in **Section 5.2.2**.



**CAUTION**  
This equipment contains ESDS Devices, static handling procedures are to be observed. Refer to the personal safety pages.

2. On the Control Board, referring to **Figure 13** overleaf, carry out the following:
  - 2.1. Disconnect the fan power cable from connector 'P8FAN'.
  - 2.2. Disconnect the DC power cable from connector 'VDC'.
  - 2.3. Disconnect the Tx, Rx and MMI RJ45 cables from the RJ45 sockets 'TX', 'RX1' and 'S3 MMI' respectively.
3. On the SDB670 rear panel, remove the four socket fasteners from the 9-way and 25-way connectors.
4. On the Control Board, release the six screws that secure the Control Board to the mounting pillars.
5. Carefully lift out the Control Board from the unit.

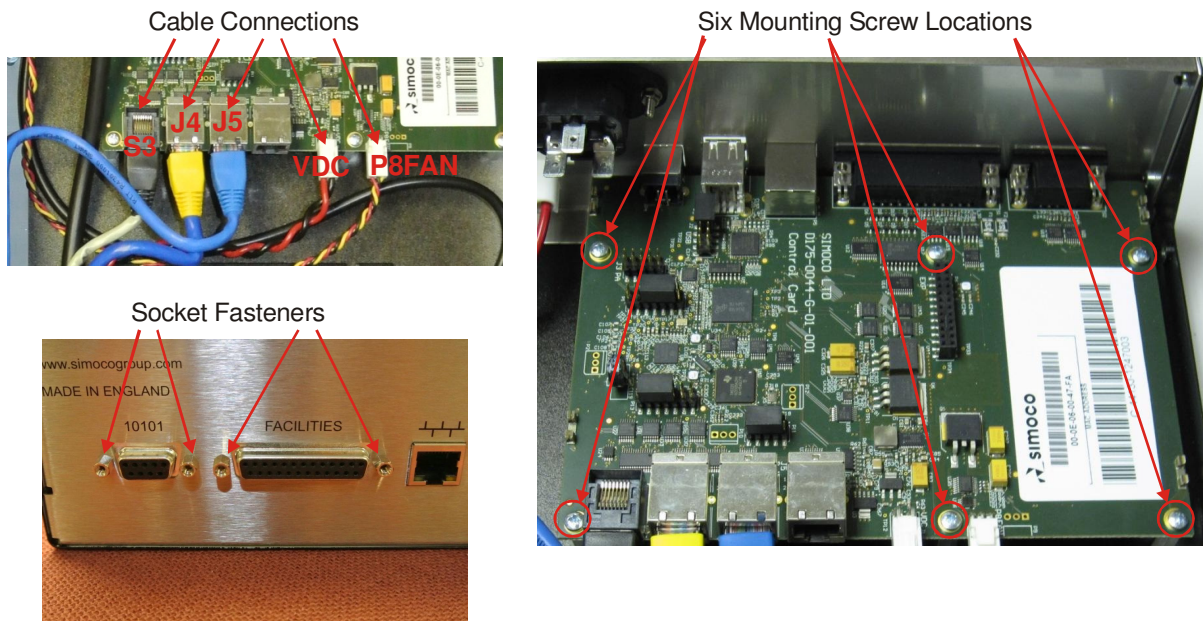

Figure 13. Removing the Control Board.

### 6.2.6 To Remove the PSU and Fuse Board Assembly (AC version only)

1. Remove the lid and open the SDB670 as detailed in **Section 6.2.2**.

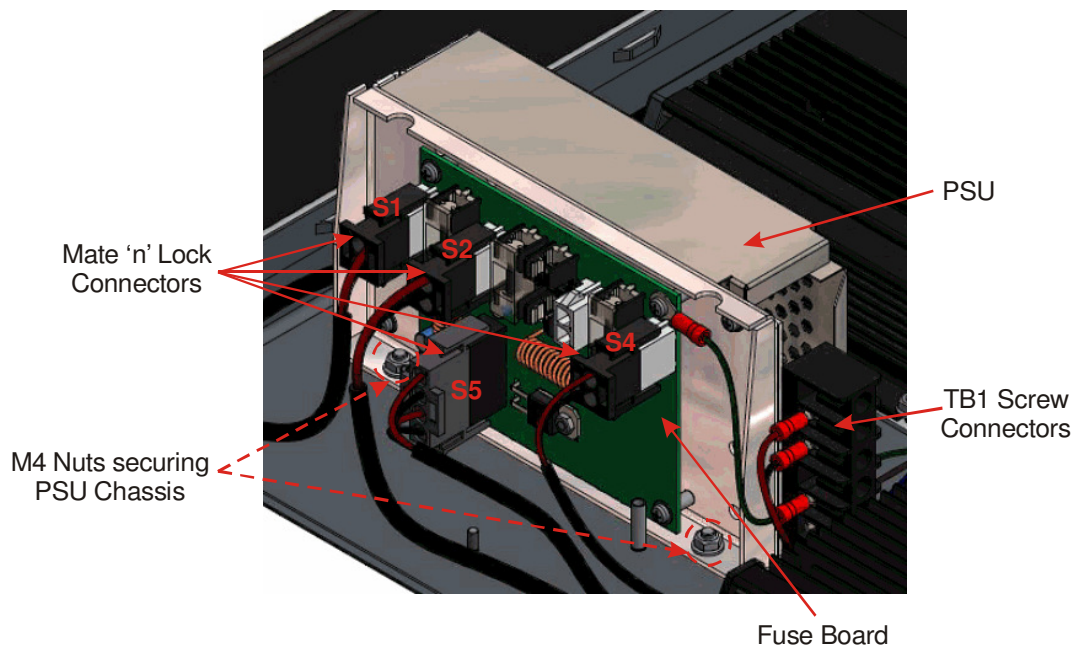

Figure 14. Removal of PSU and Fuse Board Assembly (AC version only).

2. On the Fuse Board, disconnect the following cables:
  - 2.1. The Tx Assembly power cable from connector 'S1'.
  - 2.2. The Rx Assembly power cable from connector 'S2'.
  - 2.3. The Control Board power cable from connector 'S4'.
  - 2.4. The DC power in and Battery Back-up out cable from connector 'S5'.

3. On the PSU, disconnect all the screw connections from 'TB1'.
4. Referring to **Figure 14** above, remove the two M4 nuts that secure the PSU Support Chassis to the SDB670 chassis.
5. The PSU Support Chassis complete with Fuse Board and PSU can now be removed from the unit.

### 6.2.7 To Remove the Rear 50 W Fan Assembly

1. Remove the lid and open the SDB670 as detailed in **Section 6.2.2**.
2. On the Control Board, disconnect the Fan power cable from connector 'P8FAN'.
3. On the rear panel, remove the two M3 x 6 mm screws (one each side) that secure the Fan chassis to the rear panel (see **Figure 15** below).
4. On the Heat Sink assembly, remove the four M3 x 6 mm screws (two each side) that secure the Fan chassis to the Heatsink.
5. Carefully feed the fan power cable through the rear panel and through the Heat Sink assembly.
6. On the Fan chassis, remove the four self tapping screws that secure the Fan and Fan Guard to the Fan chassis.

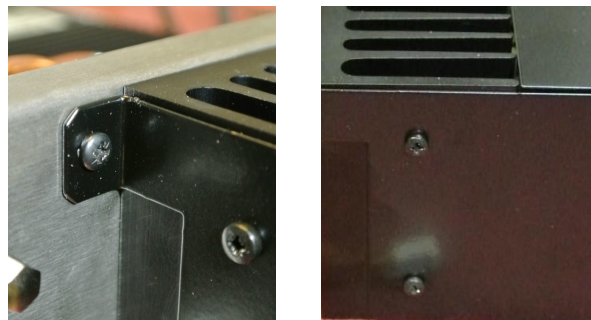

**Figure 15. Removal of Fan Assembly.**

### 6.2.8 To Remove the MMI Board Panel

1. Remove the lid and open the SDB670 as detailed in **Section 6.2.2**.
2. Remove the Rx Assembly as detailed in **Section 6.2.4**.
3. On the MMI Board, disconnect the Control Board to MMI cable from the 'S1' RJ45 socket.
4. On the MMI Board, remove the six securing screws and remove the MMI Board from the front panel.

### 6.2.9 To Remove the Internal Fan Assembly

1. Remove the lid and open the SDB670 as detailed in **Section 6.2.2**.
2. Disconnect the fan power cable from the Mate-n-lok connector of the Internal Fan Extension cable.
3. Remove the two 4 mm nuts that secure the fan cradle to the chassis.
4. Remove the four M3 screws that secure the fan to the fan cradle.

## 6.3 REASSEMBLY

In general, the re-assembly procedures are the reverse of the disassembly procedures. If there are any differences or there are any special areas of concern, they are described in this section.

### 6.3.1 To Fit the Internal Fan Assembly

**Note.**

***When fitting the internal fan to the fan cradle, it should be orientated so that the fan power cable can be routed out of the cable slot near the top of the cradle.***

- 1 Fit the internal fan into the fan cradle and secure in place with the four M3 screws.
- 2 Locate the fan cradle (complete with fan) onto the 2 studs in the SDB670 chassis. Secure in place with the two 4 mm nuts.
- 3 Connect the fan power cable to the Mate-n-lok connector on the Internal Fan Extension Cable.

### 6.3.2 To Fit the MMI Board

- 1 Carefully place the MMI Board onto the front panel and secure in place with the six securing screws.
- 2 On the MMI Board, connect the Control Board to MMI Cable to the 'S1' RJ45 socket.

### 6.3.3 To Fit the Heat Sink Fan Assembly

**Note.**

***When fitting the Fan to the Fan chassis, it should be orientated in such a way that the fan power cable can be routed through the heatsink at its shortest point.***

- 1 Fit the 50 W Fan and Fan Guard to the 50 W Fan Support Chassis using the four self-tapping screws supplied with the fan.
- 2 On the SDB670 rear panel, carefully feed the fan power cable through the hole provided in the Heat Sink assembly and in the rear panel.
- 3 On the Heat Sink assembly, using the four M3 x 6 mm screws, secure the Fan Support Chassis to the Heat Sink.
- 4 On the SDB670 rear panel, using the two M3 x 6 mm screws, secure the Fan Support Chassis to the rear panel.
- 5 On the Control Board, connect the fan power cable to the 'P8FAN' connector.

### 6.3.4 To Fit the PSU and Fuse Board Assembly (AC version only)

- 1 Taking care not to trap any cables, position the PSU Chassis (complete with Fuse Board and PSU attached) onto the two M4 locating studs on the SDB670 chassis. Secure in place with the two M4 hexagonal nuts.
- 2 On the Fuse Board, connect the following cables:
  - 2.1 The Tx Assembly power cable to connector 'S1'.
  - 2.2 The Rx Assembly power cable to connector 'S2'.



- 2.3. The Control Board power cable to connector 'S4'.
- 2.4. The DC power in and Battery Back-up out cable to connector 'S5'.
3. On the PSU, connect the power cables to the screw connections of 'TB1' as detailed in **Table 15** below.

**Table 15. PSU TB1 Connections.**

TB1 Terminal	Cable Colour	Details	
+V	Red	+ve DC Output to S5 (VIN pin) connector on Fuse Board.	
-V	Black	-ve DC Output to S5 (top 0V pin) connector on Fuse Board.	
FG	Green/Yellow	Earth connection to SDB670 chassis.	
	Green/Yellow	Earth wire	AC mains Input from rear panel.
L	Brown	Live wire	
N	Blue	Neutral wire	

### 6.3.5 To Fit the Control Board



#### CAUTION

This equipment contains ESDS Devices, static handling procedures are to be observed. Refer to the personal safety pages.

1. Carefully place the Control Board into the SDB670 chassis, ensuring that all the connectors are correctly located in their respective cut-outs on the rear panel and that the Control Board is correctly located on the six PCB mounting pillars.
2. Once in position, secure the Control Board into position on the six PCB mounting pillars with the six screws provided.
3. On the SDB670 rear panel, secure the control boards' 9-way and 25-way connectors to the chassis with the four socket fasteners.
4. On the Control Board, carry out the following:
  - 4.1. Connect the fan power cable to connector 'P8FAN'.
  - 4.2. Connect the Control Board DC power cable to connector 'UDC'.
  - 4.3. Connect the Tx, Rx and MMI RJ45 cables to the 'TX', 'RX1' and 'S3 MMI' RJ45 sockets respectively.

### 6.3.6 To Fit the Rx Assembly

1. Taking care not to trap any cables, position the Rx Assembly onto the four M4 locating studs on the SDB670 chassis. Secure in place with the four M4 hexagonal nuts.
2. On the Rx Assembly, referring to **Figure 12**, carry out the following:
  - 2.1. Connect the Rx RF cable to the BNC socket.
  - 2.2. Connect the Rx Engine to Control Board cable to the RJ45 socket.

3. On the Fuse Board, connect the Rx Assembly power cable to socket 'S2'.

### 6.3.7 To fit the Tx Assembly



**WARNING**  
**HEAT SINK COMPOUND. DOW CORNING DC340 HEAT SINK COMPOUND IS USED IN THE MAINTENANCE OF THIS EQUIPMENT. REFER TO THE PERSONAL SAFETY PAGES.**

**Note.**

*Care should be taken to support the Heat Pipe Assembly during assembly and disassembly operations.*

1. If required, fit the Heat Pipe Array to the Tx Assembly as follows:
  - 1.1. On the Heat Pipe Array, referring to **Figure 16** below, apply a small amount of Dow Corning DC340 Heatsink Compound to the Tx engine mating surface.

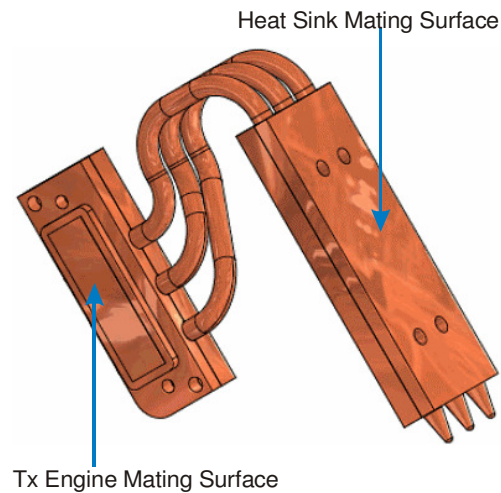

Apply a small amount of Dow Corning DC340 Heat Sink compound to mating surfaces.

**Figure 16. Heat Pipe Array.**

- 1.2. Place the Heat Pipe Array onto its location on the Tx Assembly and secure in place with the two M4 x 16 mm Cap Head screws and two M3 x 25 mm Pan Head screws.
2. On the Heat Pipe Array, referring to **Figure 16** above, apply a small amount of Dow Corning DC340 Heatsink Compound to the heatsink mating surface.
3. Taking care not to trap any cables, position the Tx Assembly onto the four M4 locating studs on the Tx Engine Adjustment Chassis. Ensure that the Heat Pipe Array is correctly aligned with the Heatsink.
4. Secure the Heat Pipe Array to the Heatsink with the four M4 x 20 mm socket cap head screws.
5. Secure the Tx Assembly to the Tx Engine Adjustment Chassis with the four M4 hexagonal nuts.
6. On the Tx Assembly, referring to **Figure 11**, carry out the following:
  - 6.1. Connect the Tx RF cable to the BNC socket.

- 6.2. Connect the Tx Engine to Control Board cable to the RJ45 connector.
7. On the Fuse Board, connect the Tx Assembly power cable to socket 'S1'.

## 7 SPARES

### 7.1 SERVICE CONCEPT

The SDB670 DMR Base Station has been designed to provide a fully integrated DMR base station repeater, using common core electronics, software and interfacing.

It is a requirement that once the customer has purchased equipment, Simoco can follow this up by providing an ongoing, high level of customer support together with a competitive and professional servicing activity.

There are three levels of service available, these are detailed in **Table 16** below.

**Table 16. Service Levels.**

Level	Activity	Recommended Spares	Recommended Test Equipment and Tools
1	<p>This is intended to achieve rapid turn around by:</p> <ul style="list-style-type: none"> <li>• Complete replacement of transceiver or ancillaries.</li> <li>• Replacement of sub-assemblies.</li> <li>• Reprogramming.</li> <li>• Checking/replacement of fuses.</li> </ul> <p>Faulty units are to be returned to a Level 2 service facility with an attached fault report.</p> <p>This level of service should not exceed 20 minutes.</p>	<p>Fans. Spare cable assys. Replacement fuses.</p>	<p>Multimeter. PC with Programmer. Engineering handset. Small flat-blade screwdriver. Small cross-head screwdriver. Large pozi-drive screwdriver.</p>
2	<p>Level 2 service includes Level 1 with the addition of fault rectification by:</p> <ul style="list-style-type: none"> <li>• Replacement of PCB, mechanical component, or cable assembly.</li> <li>• Cosmetic repair.</li> </ul>	<p>Listed in Level 2 Spares Schedule. Spare parts available to order from Central Spares.</p>	<p>As above + service aids and test equipment.</p>
3	<p>Repair by PCB or mechanical component replacement, Cosmetic repair. Repair of PCB to component level in Central Repair Unit (CRU).</p>	<p>Listed in Level 2 Spares Schedule. Radio PCB components only available to CRU.</p>	<p>As above + service aids and test equipment.</p>

### 7.2 LEVEL 2 SPARES SCHEDULE

#### 7.2.1 SDB670 DMR Base Station

The recommended spares schedule for Service Level 2 is shown overleaf in **Table 17**.

Table 17. Service Level 2 Recommended Spares Schedule.

Item	Description		Part Number	
1	Case Lid		D175-0010-M-02-001	
2	DMR Control Board		D175-0044-C	
3	MMI Board		D175-0060-C	
4	Fuse Board Assembly (AC)		D175-0023-A	
	Fuse Board Assembly (DC)		D175-0027-A	
5	Power Supply Unit 15 V, 10 A		52701-0000040-0	
6	Tx Assembly (25 W)	AC	136 – 174 MHz	6102-350-17910
		TU	400 – 480 MHz	6102-350-17710
		UW	440 – 500 MHz	Contact Simoco
7	Rx Assembly (25 W)	AC	136 – 174 MHz	6102-350-17810
		TU	400 – 480 MHz	6102-350-17610
		UW	440 – 500 MHz	Contact Simoco
8	Cable Assembly RF (Tx)		D175-0036-W	
9	Cable Assembly RF (Rx)		D175-0037-W	
10	Cable Assembly RJ45 (C/Bd – MMI)		D175-0032-W	
11	Cable Assembly DC Power		D175-0031-W	
12	Cable Assembly Control Board Power		D175-0035-W	
13	Heat Pipe Array		D175-0020-A-01-001	
14	Case		D175-0001-M	
15	Front Panel		D175-0105-M	
16	Internal Fan, 80 mm		AK-181BKT-C	
17	Fan 80 x 80, 12 V		D175-0028-A	

## 7.3 WARRANTY

Unless superseded by specific contractual/supply agreements, the normal statutory 24 month warranty will apply to all base stations and ancillaries.

### 7.3.1 Service Within and Out Of Warranty

Please contact our Customer Service department regarding support of either type. In some countries a local Simoco agent may be responsible for providing this service. See the Support page for contact details.

### 7.3.2 Ancillary Items

Please contact our Customer Service department regarding service, for replacement of these parts. See the Support page for contact details.

### 7.3.3 Unpacking Equipment

Any damaged or missing parts must be notified to Simoco or their agent in writing within 10 days of receipt.

## 7.4 SOFTWARE POLICY

Software provided by Simoco shall remain the Company's property or that of its licensors and the customer recognises the confidential nature of the rights owned by the Company.

The customer is granted a personal, non-exclusive, non-transferable limited right of use of such software in machine-readable form in direct connection with the equipment for which it was supplied only.

In certain circumstances, the customer may be required to enter into a separate licence agreement and pay a licence fee, which will be negotiated at the time of the contract.

The customer undertakes not to disclose any part of the software to third parties without the Company's written consent, nor to copy or modify any software. The Company may, at its discretion, carry out minor modifications to software. Major modifications may be undertaken under a separate agreement, and will be charged separately.

All software is covered by a warranty of three months from delivery and, within this warranty period, the Company will correct errors or defects, or at its option, arrange free-of-charge replacement against return of defective material.

Other than in the clause above, the Company makes no representations or warranties, expressed or implied such, by way of example, but not of limitation regarding merchantable quality or fitness for any particular purpose, or that the software is error free, the Company does not accept liability with respect to any claims for loss of profits or of contracts, or of any other loss of any kind whatsoever on account of use of software and copies thereof.

APPENDIX A

DMR CONTROL BOARD BLOCK DIAGRAM

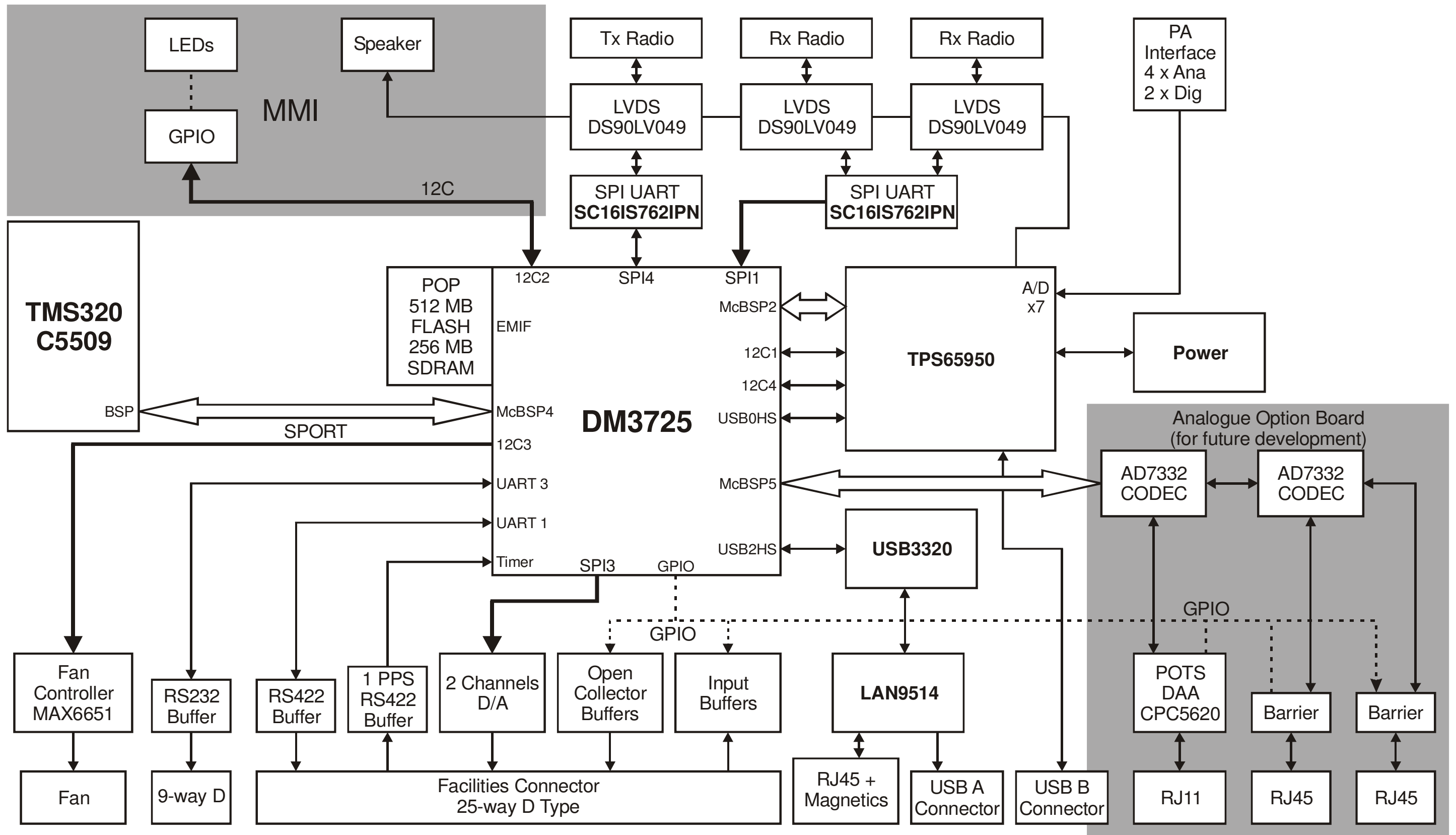

Figure A1. DMR Control Board Block Diagram.



**SIMOCO GROUP**

Global Headquarters: Field House, Uttoxeter Old Road, Derby DE1 1NH

United Kingdom: Tel: 08717 411 050  
Fax: 08717 411 049

International: Tel: +44 (0) 1332 375 671  
Fax: +44 (0) 1332 375 672

[www.simocogroup.com](http://www.simocogroup.com)