



Xfin Blade

SERVICE MANUAL

XFIN-BLADE-SM

Issue 3.0

February 2008
© Team Simoco 2008

Team Simoco Ltd.
Field House,
Uttoxeter Old Road
Derby
DE1 1NH
Tel: +44 (0) 1332 375 500
FAX: +44 (0) 1332 375 501
www.teamsimoco.com



Certificate number ...3358/02.....

DECLARATION

The performance figures quoted are subject to normal manufacturing and service tolerances. The right is reserved to alter the equipment described in this manual in the light of future technical development.

COPYRIGHT

All rights reserved. No part of this publication may be reproduced in any form or by any means without the prior written permission of Team Simoco Ltd.

ERRORS AND OMISSIONS

The usefulness of this publication depends upon the accuracy and completeness of the information contained within it. Whilst every endeavour has been made to eliminate any errors, some may still exist. It is requested that any errors or omissions noted should be reported to:

Technical Documentation
Team Simoco Ltd
Field House
Uttoxeter Old Road
Derby
DE1 1NH
UK

Tel: +(44) 01332 375 627

E-mail: techsupport@teamsimoco.com

DOCUMENT HISTORY

Issue	Date	Comments
0.1	Sept 2005	Skeleton document created.
0.2	Mar 2006	Draft submitted for internal review by Development.
0.3	Apr 2006	Diagrams added.
0.4	Aug 2006	Product Variants and Spares information received.
1.0	Nov 2006	Added details on PSTN & RJ45 serial ports, E&M linking corrected.
2.0	Nov 2007	Updated Test-Point information.
3.0	Feb 2007	Added Radio Frequency Hazard Information

WARNINGS AND CAUTIONS

WARNING

The Power Amplifier Module uses semiconductor devices containing Beryllium Oxide. Dust from this oxide is toxic and, if inhaled or skin contact is made, can be hazardous to health.

No danger can arise from normal handling, but no attempt should be made to break open or tamper with these devices in any way.

These items should not be discarded with industrial or domestic waste.

WARNING

To avoid RF injury, do not touch the Antenna when the Transmitter is in use.

Do not operate transmitter with antenna disconnected – RF burn hazard.

WARNING

The weight of a fully assembled Base Station in the wall mount is approx **10kg**.

Two people should be used to lift the unit in this form.

WARNING

When drilling walls, check first for any buried cables or pipes.

WARNING

Disconnect Mains Electricity before working on the unit with wall-mount or rack power supplies open.

Caution

During disassembly and assembly, refer to the 'Torque Settings' section in this manual.

Caution

Preparing the radio for alignment will erase from the radio all customer PMR and Trunking configuration data (channel, signalling information etc). The only data retained by the Alignment Tool is the factory alignment data for the radio (DAC settings for TX power, front-end tuning etc).

TABLE OF CONTENTS

DECLARATION..... 2

COPYRIGHT 2

ERRORS AND OMISSIONS..... 2

DOCUMENT HISTORY 2

WARNINGS AND CAUTIONS..... 4

TABLE OF CONTENTS..... 5

1 INTRODUCTION..... 10

1.1 General..... 10

2 PRODUCT CODES..... 11

2.1 Serial number 11

 2.1.1 Hardware Variant Code 11

 2.1.2 MAC Address..... 11

 2.1.3 Modification State 11

3 DESCRIPTION..... 13

3.1 Ventilation..... 13

3.2 SRM9000 Sub-assembly..... 14

3.3 Specifications..... 14

 3.3.1 General..... 14

 3.3.2 Transmitter..... 15

 3.3.3 Receiver..... 16

3.4 Front Panel Controls..... 16

 3.4.1 LED Indicators 16

 3.4.2 LCD..... 17

 3.4.3 Control Knob..... 17

 3.4.4 MMI RJ45 Connector 18

3.5 Rear Panel Connectors..... 18

 3.5.1 Tx/Rx..... 19

 3.5.2 Power..... 19

 3.5.3 Fuses 20

 3.5.4 Ethernet 20

 3.5.5 RS232 Serial (D-Sub) 21

 3.5.6 RS232 Serial (RJ45)..... 21

3.5.7	USB Connector	21
3.5.8	Line 1 & 2 (RJ45)	22
3.5.9	Facilities.....	22
3.5.10	PSTN Port (RJ11)	23
4	TECHNICAL DESCRIPTION	25
4.1	MMI Board	25
4.1.1	Description.....	26
4.2	Control Board	27
4.2.1	Circuit Board Layout	27
4.2.2	Circuit Description.....	29
4.2.2.1	LEDs	29
4.2.2.2	Test Points.....	29
4.2.2.3	DSP	33
4.2.2.4	Power.....	34
4.2.2.5	IXP	34
4.2.2.6	CoDec.....	35
4.2.2.7	Audio Interface.....	35
4.2.2.8	PSTN Interface	36
4.2.3	Links	37
4.3	Receiver and Transmitter Modules.....	39
4.3.1	Frequency Bands	39
4.3.2	Receiver.....	39
4.3.2.1	Front-end Filters and Rx Front-end Amplifier	39
4.3.2.2	First Mixer and IF Section.....	41
4.3.2.3	Quadrature Demodulator	41
4.3.2.4	Receiver Audio Processing.....	41
4.3.3	Transmitter.....	41
4.3.3.1	Drivers and PA Stages	42
4.3.3.2	Tx Power Control	44
4.3.3.3	Antenna Changeover and Harmonic Filter	44
4.3.3.4	Transmitter Audio Processing.....	44
4.3.4	Frequency Synthesis	45
4.3.4.1	General.....	45
4.3.4.2	PLL	45
4.3.4.3	VCO	45
4.3.4.4	Negative Bias Generator and Loop Filter	45
4.3.4.5	Phase Modulator.....	46
4.3.4.6	Reference Oscillator	46
4.3.5	RF Sub-Assembly Internal Control Logic.....	48
4.3.5.1	DSP and FPGA.....	49
4.3.5.2	DSP Clock Oscillator	49
4.3.6	RF Sub-Assembly Internal Memory	49
4.3.6.1	Multiplexer	49
4.3.7	RF Sub-Assembly Internal Power Supplies	50

4.3.7.1	Power On Function	50
4.3.7.2	Power Lines	50
4.4	Antenna Requirements	52
4.5	Power supplies.....	52
4.6	Configuration	52
4.7	Adjustment and Alignment.....	52
5	MAINTENANCE	53
5.1	Torque Settings.....	53
5.2	Disassembly	53
5.2.1	To Remove the Blade from a Rack.....	53
5.2.2	To Open the Blade.....	54
5.2.3	To Remove a Tx or Rx Assembly.....	54
5.2.4	To Remove the Control Board	55
5.2.5	To Remove the Front Assembly.....	55
5.2.6	To Remove the MMI Board	56
5.2.7	To Remove a Fan	56
5.3	Re-Assembly	56
5.3.1	To Fit an MMI Board	56
5.3.2	To Fit the Front Assembly.....	56
5.3.3	To Fit the Control Board	56
6	PRODUCT VARIANTS AND ACCESSORIES.....	58
6.1	Variants.....	58
6.2	Accessories	58
6.2.1	TSF-ACCORD	59
6.2.2	Duplexers, Combiners, Cavities, RSA Units	59
6.2.3	TSF-EARS	60
6.2.4	TSF-PROG	60
6.2.5	Blade Shelves.....	60
6.2.6	TSF-1BS PSUTRAY	60
6.2.6.1	TSF-1BS PSUTRAY Specifications	60
7	SPARES.....	62
7.1	Service Concept.....	62
7.2	Level-2 Spares Schedule.....	63
7.2.1	XFIN BLADE (INTERNAL PSU VERSION)	63
7.2.2	Assembly Item List.....	64
7.3	Warranty.....	65
7.3.1	Service Within and Out Of Warranty	65

7.3.2 Ancillary Items.....	65
7.3.3 Unpacking Equipment.....	66
7.4 Software Policy	66
8 LCD MENU OPERATION	68
8.1 Default Display	68
8.2 Menu Structure.....	68
8.2.1 Alarms Menu.....	69
8.2.2 Set IP Address.....	69
8.2.3 Set Position in Site.....	69
8.2.4 Set Site ID.....	69
8.2.5 Set System ID.....	69
8.2.6 Enable Screen Saver.....	69
8.2.7 Test Menu.....	69
8.2.8 Exit.....	69
9 PROGRAMMER GUIDE.....	70
9.1 Getting Started	70
9.1.1 Main Screen.....	70
9.2 Database	70
9.2.1 Creating a New Database.....	71
9.2.2 Opening a Database.....	71
9.3 Communications Settings.....	71
9.3.1 Connection Type.....	71
9.3.2 Serial Communications.....	71
9.3.3 Ethernet Communications.....	72
9.3.4 Open Comms.....	72
9.4 State	72
9.5 Area Configuration.....	73
9.5.1 Edit.....	73
9.5.2 Add.....	73
9.5.3 Delete.....	73
9.5.4 Accept/Send.....	73
9.5.5 Get Record.....	74
9.5.6 Send Configuration.....	74
9.5.7 Get Configuration.....	74
9.5.8 Reset Configuration.....	74
9.5.9 Navigation Buttons.....	74
A. GLOSSARY AND ABBREVIATIONS	77

B. CONTROL CARD BLOCK DIAGRAM.....78

C. RADIO FREQUENCY HAZARD INFORMATION79

1 INTRODUCTION

1.1 GENERAL



Figure 1.1 - Front view of the Xfin Blade.

Brief Description: The Xfin Blade is a 1U trunking system with an integrated basestation and the capability to provide a control and/or traffic channel. It incorporates the established MPT1327 trunking standard with next generation hardware and VoIP technology. A trunked site consists of a number of Blade units which are inter-connected using standard CAT5 Ethernet cable.

2 PRODUCT CODES

The following information is displayed on the Type Approval Label located on the chassis behind the speaker housing.

2.1 SERIAL NUMBER

The product serial number is broken down as follows:

Digits	
1-3	Hardware configuration; XBI = Xfin 25W internal PSU, XB0 = Xfin 25W external PSU, XBP = Power Blade 100W
4	Hardware version; P = prototype, 1-9, A-Z = production releases
5	Software version; P = prototype, 1-9, A-Z = production releases
6-7	Reserved
8-9	Tx & Rx frequency band designation (alphanumeric)
10-11	Year of manufacture
12-13	Week of manufacture
14-16	Unique serial number

2.1.1 Hardware Variant Code

The hardware code is a 5-digit code consisting of:

Digits	
1-3	Hardware configuration; XBI = Xfin 25W internal PSU, XB0 = Xfin 25W external PSU, XBP = Power Blade 100W
4-5	Tx & Rx frequency band designation (alphanumeric)

2.1.2 MAC Address

Each Blade is assigned a unique 12-character alphanumeric MAC address.

2.1.3 Modification State

Where changes are made to hardware or software between major releases, this will be recorded on the %Mod State+tick-boxes (A . D) on the Type Approval Label.

3 DESCRIPTION

The Blade is a 1U high by 19+ wide rack-mountable unit containing two SRM9000 sub-assemblies, a control card, and a fan bulkhead which mates with the angled front panel and MMI card.

There is also provision for fitting a high power amplifier or integrated power supply option.

3.1 VENTILATION

In order to provide full-power continuous operation in any orientation and in a 1U envelope, the Blade uses forced air-cooling. A pair of fans draws air in from an air intake located underneath the front lip of the angled front panel. This air is compressed by a baffle that directs the airflow underneath the heatsink of the SRM9000 sub assemblies. A second pair of fans is used for the high-power amplifier option if fitted.

Fans are located to maximise the cooling for the transmitting module. Air is exhausted through a grilled area on the rear panel immediately below the electrical connectors.

Vent holes in the internal baffle allow a small amount of air to bleed diagonally through the top section of the chassis to ensure that hot spots do not form on the component side of the sub-assemblies.

The fans are mounted in a bulkhead located immediately behind the front panel. The front panel, MMI board and fan bulkhead are separately assembled and removed from the unit as sub-assemblies.

The fans, loudspeaker and indicator LEDs are all controlled from the MMI PCB that fits into this sub-assembly. The fans are not only speed controlled to minimise noise and wear, but their speed is also monitored to provide early warning of failure.

In normal operation, the fans are turned on to full speed to minimise any possibility of a stall, the speed is then turned down based upon equipment temperature. Even if the temperature is very low, fans are always kept running at a low speed. Temperature is sensed from a Thermistor located on the underside of the control board. This Thermistor protrudes into the airflow from the transmit PA module.

When installing the Blade it is important to ensure that adequate ventilation is provided for each base station unit. A minimum free-area of 72cm² is recommended per base

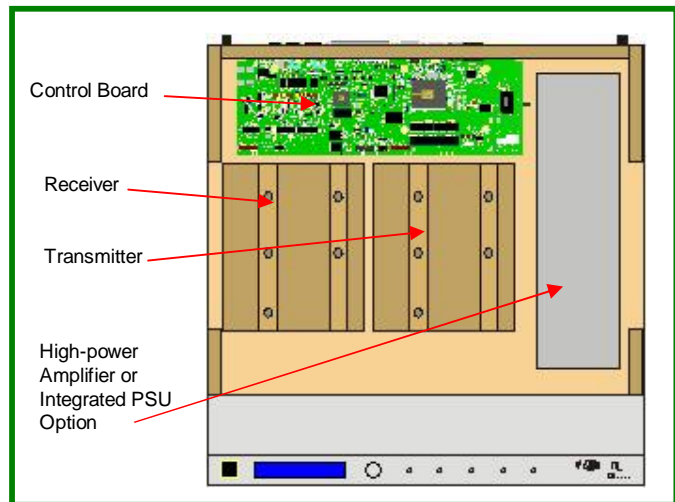

Figure 3.1 - Layout of the Blade with the top lid removed

station at the inlet AND at the outlet. This should be increased if air has to be drawn through ducts or has to be deflected around corners.

Noise and dust build up can be reduced by keeping cabling and other obstructions out of the main airflows.

There are no dust filters fitted in this product. If it is to be used in very dirty environments, then additional steps should be taken to prevent ingress of dust as this will affect thermal performance. Filters should only be used in external cabinets if they can be regularly maintained.

3.2 SRM9000 SUB-ASSEMBLY

The RF performance of this product is derived from a pair of SRM9000 RF PCBs mounted on a Heatsink sub-assembly that is designed to permit continuous operation at full power. The sub-assembly also provides RF screening, so it is important that it is accurately assembled and reassembled.

The sub-assembly has a plate attached to the rear edge with two quarter-turn fasteners for rapid removal.

The unit is retained in the Blade chassis by the front edge of the Heatsink that inserts underneath the fan baffle, the rear of the subassembly is held in place by the quick release fasteners.

These units are electrically identical to SRM9000 and are also fully interchangeable in the 25W power group (the Transmit module is different for the 100W systems). Control is provided via the 26-way ribbon connector. Power is supplied via the DB-15 connector and RF signals are coupled to the BNC sockets with double-screened cables.

3.3 SPECIFICATIONS

3.3.1 General

Channel Bandwidth	12.5kHz (11K0F3EJN), 20kHz (14K0F3EJN) or 25kHz (16K0F3EJN) selectable per channel		
Modulation	Freq. F3E (voice) pre-emphasised/flat, or FFSK data (1200 or 2400bps)		
Frequency Bands	E0: 66-88MHz. KM: 208-245MHz. TK: 400-450MHz. WR: 470-530MHz.	AC: 136-174MHz. R0: 310-350MHz. TU: 400-480MHz	K1: 174-208MHz. R1: 335-375MHz. UW: 440-500MHz.
Stability	± 2.0ppm		
Temperature	-25C to +55C Operating (Full Spec.) -40C to +80C Storage		
Antenna Connect	2 x 50Ω female N-type		
Environmental	IP20 ingress protection, Humidity <95% non-condensing		

Inputs/Outputs	Serial interface with 1x audio connection (RJ45 . front panel) 2x line/audio (2/4-wire) connections with E&M signalling (2x RJ45 with internal shield) Programmable facilities connector (37 way D-type) 2x RS232 serial connections (9 way D-type, RJ45 with internal shield) Ethernet IP interface (10/100 base-T magnetic RJ45 with external shield) USB connector (Type-B USB Socket) PSTN connector (6/4 RJ-11 socket) Power connector (5 Pin, 25 D-shell)
Type Approval	CE Type approvals to R&TTE Directive 1999/05/EC: EN300-086 Radio, EN300-113 Data, EN301-489-05 EMC, EN300-219 Signal, EN60950 Safety, TBR15, 17 and 21 Line
Dimensions	44mm(1U) High x 437mm Wide x 450mm Deep (Excluding cables and ears)
(In Wall Mount)	125mm High x 465mm Wide x 470mm Deep
Weight	6.95 kg

3.3.2 Transmitter

25W

Transmit Power	1W to 25W in steps . 2 levels (high/low), selectable per channel
Tx Current Consumption	Typical: 25W: 7A @13.6V (20°C) Max: 25W: 10A @13.6V + 10.0A @27.3V (fans & audio on maximum)
Duty Cycle	100%
Audio Distortion	<5% at 1kHz, 60% deviation
Audio Frequency Response	+1db to . 3db of pre-emphasised 300 to 3000Hz on 25kHz channel, 300 to 2550Hz on 12.5kHz channel
Hum and Noise	>40db (12.5kHz), 45db (25kHz)
Transmit Rise Time	<25ms

100W

Transmit Power	10W to 100W in steps, selectable per channel
-----------------------	--

Tx Current Consumption	Typical: 100W: 5.7A @13.6V + 6.0A @27.3V (20°C) Max: 100W: 8.85A @13.6V + 10.0A @27.3V (fans & audio on maximum)
Duty Cycle	100%
Audio Distortion	<5% at 1kHz, 60% deviation
Audio Frequency Response	+1db to . 3db of pre-emphasised 300 to 3000Hz on 25kHz channel, 300 to 2550Hz on 12.5kHz channel
Hum and Noise	>40db (12.5kHz), 45db (25kHz)
Transmit Rise Time	<25ms

3.3.3 Receiver

Sensitivity	Voice: ≥ 12 db SINAD for $0.3\mu V_{pd}$ (typically >20db) for 25kHz channel. Data: typical FFSK performance for $<10^{-2}$ BER (<20%MER): $0.3\mu V_{pd}$. 1200 baud in 12.5kHz & 1200/2400 baud in 25 kHz, $0.5\mu V_{pd}$. 2400 baud in 12.5kHz channel. [Ref: EN300-113-1:9.1]
Rx Current Consumption	Typical: 1.0A (20°C) Max: 1.55A (fans & audio on maximum)
Selectivity	>73db (25kHz), >63db (12.5kHz)
Intermodulation	>70db (ETSI method)
Audio Response	± 3 dB of de-emphasised 300 to 3000Hz with CTCSS
Audio Output	$2W_{rms}$ internal monitor speaker
Blocking	>95dB at ± 1 Mhz
Hum and Noise	>40dB (12.5kHz) . CCITT weighted

3.4 FRONT PANEL CONTROLS

3.4.1 LED Indicators

On the front of the Blade there are the following 5 LED indicators (from left to right):

Legend	Colour	Description
Power	Green	Indicates presence of 3.3V DC
Tx	Red	Indicates unit is keyed up
Rx	Yellow	Indicates RF signal received
CC	Orange	Control Channel Activity
Alm	Red	Alarm indicator . access LCD α alarmsqmenu or connect PC to diagnose

3.4.2 LCD

On the left side of the front panel is an LCD (Liquid Crystal Display) 2-by-20 Character Display. It indicates channel (control/traffic) and network status (master/slave). It also indicates volume level for the internal monitor speaker and presents a menu system. See the LCD Menu Operation section later in the manual.

3.4.3 Control Knob

The control knob is used in conjunction with the LCD Display to operate the menu system and provide volume control.

3.4.4 MMI RJ45 Connector

This is an RJ45 connector located on the left side of the angled front panel. It offers a direct UART interface, a microphone input channel and an audio output channel. The pinout is listed below (where for the purpose of this table, pin 1 is the left-most pin when looking into the RJ45 socket).

Pin	Function
1	Tx-Data
2	Rx-Data

Pin	Function
3	N/C
4	Mic Gnd

Pin	Function
5	+Vout
6	Audio Out

Pin	Function
7	Gnd
8	Audio In

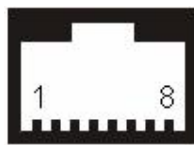

3.5 REAR PANEL CONNECTORS

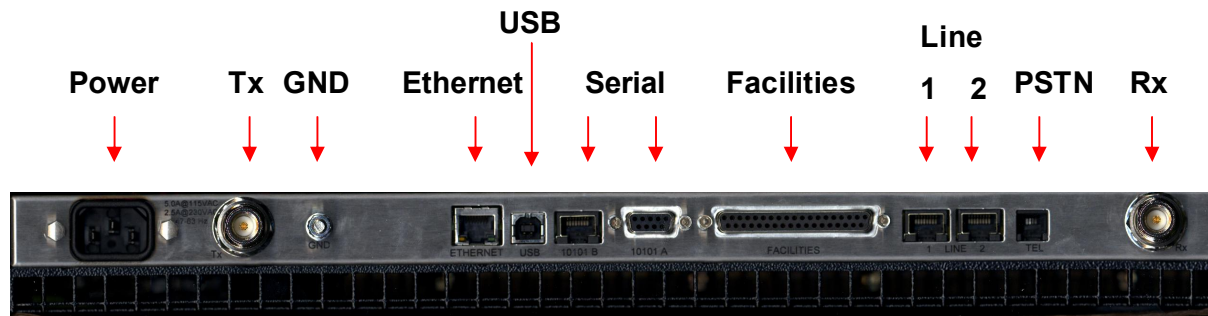

Figure 3.2 - Layout of the Xfin Blade rear panel



Figure 3.3 – View of the Xfin Blade rear panel.

3.5.1 Tx/Rx

The antenna connections on the Blade are provided with 50 Ω female N-type sockets.

Mating connectors should be galvanically compatible with nickel outer and gold centre pin to minimise passive inter-modulation.

A minimum of 85dB transmit-receive isolation should be provided by the antenna system and associated filters.

It is recommended that a good quality flexible co-axial cable is used, e.g. with double-screening braid and multi-strand copper inner.

3.5.2 Power

This is a D-type housing with 5 stud-pin locations. From left to right (looking at the rear panel) they are:

Pin	Description
1	Power amp (option). +24VDC (nom)
2	Power amp (option). DC ground
3	Chassis Ground
4	+12VDC(nom) input
5	0VDC input

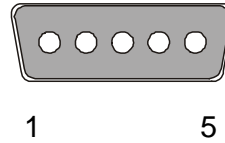

Notes: 12VDC nominal is normally supplied with 13.6VDC for battery float charge reasons.
24VDC nominal is normally supplied with 27.3VDC for battery float charge reasons.

3.5.3 Fuses

Fuse F1 on the fuse-board is a 2A quick-blow, 20 x 5mm component and protects the 12V line to the MMI PCB.

Fuse F2 on the fuse-board is a 10A quick-blow, 20 x 5mm component and protects the 24V line to the Power Amplifier, if fitted

Fuse F5 on the Xfin Control Card is a 2A quick-blow, 20 x 5mm component and protects the 12V line to the PCB.

In event of failure, the reason for the failure should be investigated prior to replacement. The fuse should only be replaced with a correctly specified component.

3.5.4 Ethernet

This is a 10/100 base-T RJ45 connection. This is a switch (not a NIC) configuration . care should be taken to use the correct cable (crossover or straight-through) when connecting to a network. The use of shielded cables is recommended, especially for VHF installations. The two indicator LEDs, integrated into the connector, show 100Mbps bandwidth detection and traffic activity. A third LED, on the Control Card shows if a connection is present.

Pin	Description
1	Eth Rx-Data, balanced input 1
2	Eth Rx-Data, balanced input 2
3	Eth Tx-Data, balanced output 1
4	NC
5	NC
6	Eth Tx-Data, balanced output 2

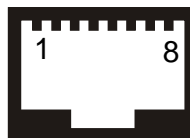

7	NC
8	NC

3.5.5 RS232 Serial (D-Sub)

This is a standard DB-9 female RS-232 socket with the following pins connected for DTE operation:

Pin	Description
1	NC
2	Tx Data, output
3	Rx Data, input
4	NC
5	GND

Pin	Description
6	NC
7	CTS, input
8	RTS, output
9	NC



3.5.6 RS232 Serial (RJ45)

This is a standard RJ45 socket with the following pins connected for DTE operation:

Pin	Description
1	NC
2	Tx Data, output
3	Rx Data, input
4	NC
5	GND

Pin	Description
6	NC
7	CTS, input
8	RTS, output

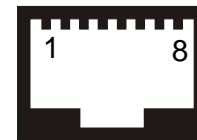

3.5.7 USB Connector

The IXP420 processor's USB is integrated, USB 1.1-compliant and supports all standard device requests issued by any USB host controller. It is an USB device-only controller. The interface supports full-speed operation and 16 endpoints and includes an integrated transceiver. There are six isochronous endpoints (three input and three output), one control endpoint, three interrupt endpoints, six bulk endpoints (three input and three output). The connector is a standard 4-pin socket (pin 1 is the bus voltage rail, 2 & 3 are the positive and negative signals of the differential USB receiver/driver respectively and pin 4 is ground).

Note: ensure that the current Blade software supports this interface before attempting to use it

3.5.8 Line 1 & 2 (RJ45)

Each of these sockets provides a pair of barriered line audio connections via RJ45 connectors. Opto-isolated E&M signalling is also available on these connectors. A pair of lines is provided so that the unit can support active line combining.

To provide DC Ground and Bias for E&M Signalling

Caution
When the following is performed, the line barrier is breached and the equipment must NOT be connected to Public Networks.

Where line barrier is not required, two fuses may be fitted in fuse-holders F3 and F4 of the control PCB (20 x 5mm, 50mA) to provide DC ground and bias for E&M signalling.

Pin	Description
1	E+
2	M-
3	4 wire Tx
4	4 wire Rx or 2 wire Tx/Rx
5	4 wire Rx or 2 wire Tx/Rx
6	4 wire Tx
7	M+
8	E-

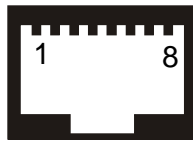

3.5.9 Facilities

This 37-way D-type can be programmed for any combination of digital inputs and outputs. Audio signals are present on certain pins, these require an adapter cable in order to re-route signals and become plug compatible with certain products.

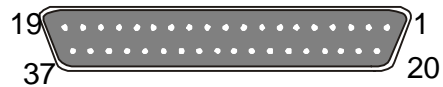

Pin	Description
1	Tx+ line connection A
2	0v
3	Rx+ line connection A
4	Rx+ line connection B
5	Tx+ line connection B

Pin	Description
14	CTCSS decode defeat
15	RSSI O/P
16	Channel line C6 (MSB)
17	Channel line C4
18	Channel line C2

Pin	Description
27	I/O 5
28	I/O 6
29	Talkthrough command
30	Squelch defeat command
31	I/O 7

6	Tx- line connection B	19	Channel line C0 (LSB)	32	Aux Rx
7	I/O 2	20	Tx- line connection A	33	I/O 8
8	I/O 4	21	Aux Tx	34	Analogue Out
9	+13.6v unswitched	22	Rx- line connection A	35	Channel line C5
10	Tx key command	23	Rx- line connection B	36	Channel line C3
11	Alarm 1	24	Squelch	37	Channel line C1
12	0v	25	I/O 1		
13	Alarm 2	26	I/O 3		

3.5.10 PSTN Port (RJ11)

This is a 6/4 RJ11 socket with the following pins connected for PSTN operation:

Pin	Description
1	NC
2	NC
3	Tip (Snoop+)
4	Ring (Ring-)
5	NC

Pin	Description
6	NC

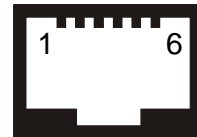

4 TECHNICAL DESCRIPTION

4.1 MMI BOARD

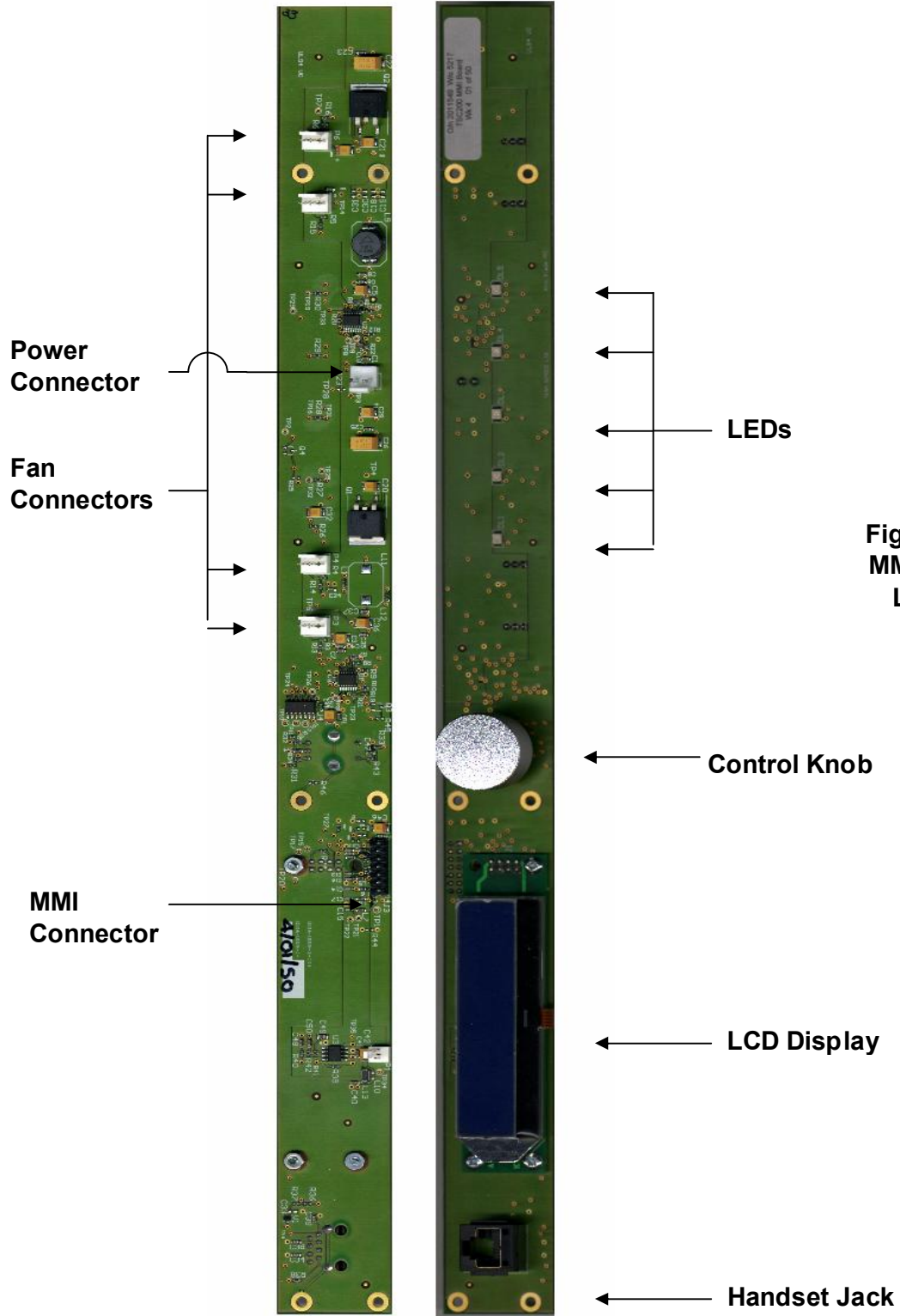

Figure 4.1 -
MMI Board
Layout

4.1.1 Description

The purpose of the MMI board is to provide the Man Machine Interface between the control card and the user.

The MMI board contains 5 LEDs for user diagnostics. It contains an LCD for displaying an interactive menu, which is accessed via a control knob. An audio amplifier is provided to drive a loud speaker at up to 2W, with volume adjustment via the control knob. An RJ45 interface for a serial port is also present.

The MMI board has a secondary function of providing the interface and drivers for the fans.

Connection to the main control board is via a 14-way ribbon cable.

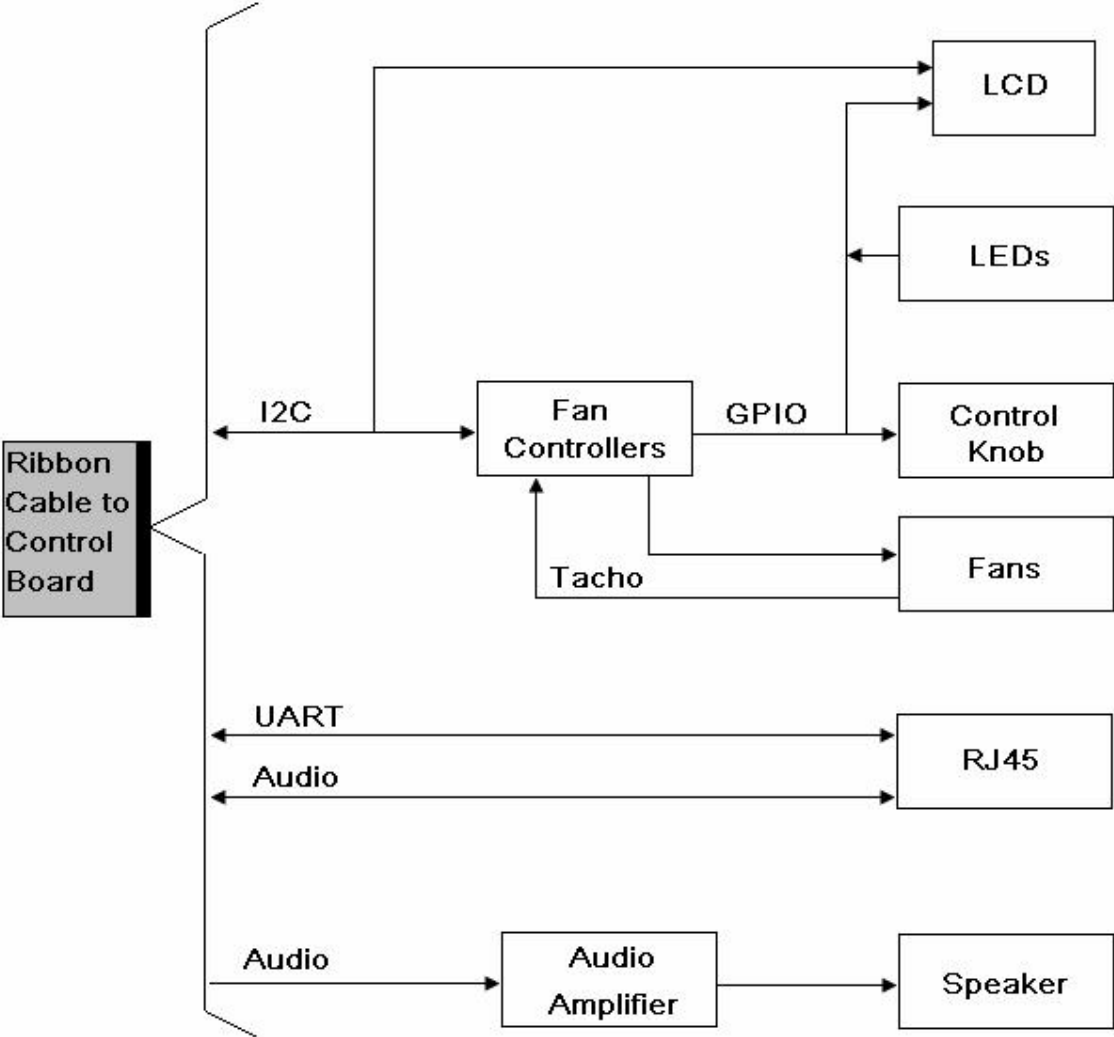

Figure 4.2 – Block Diagram of MMI Board

4.2 CONTROL BOARD

4.2.1 Circuit Board Layout

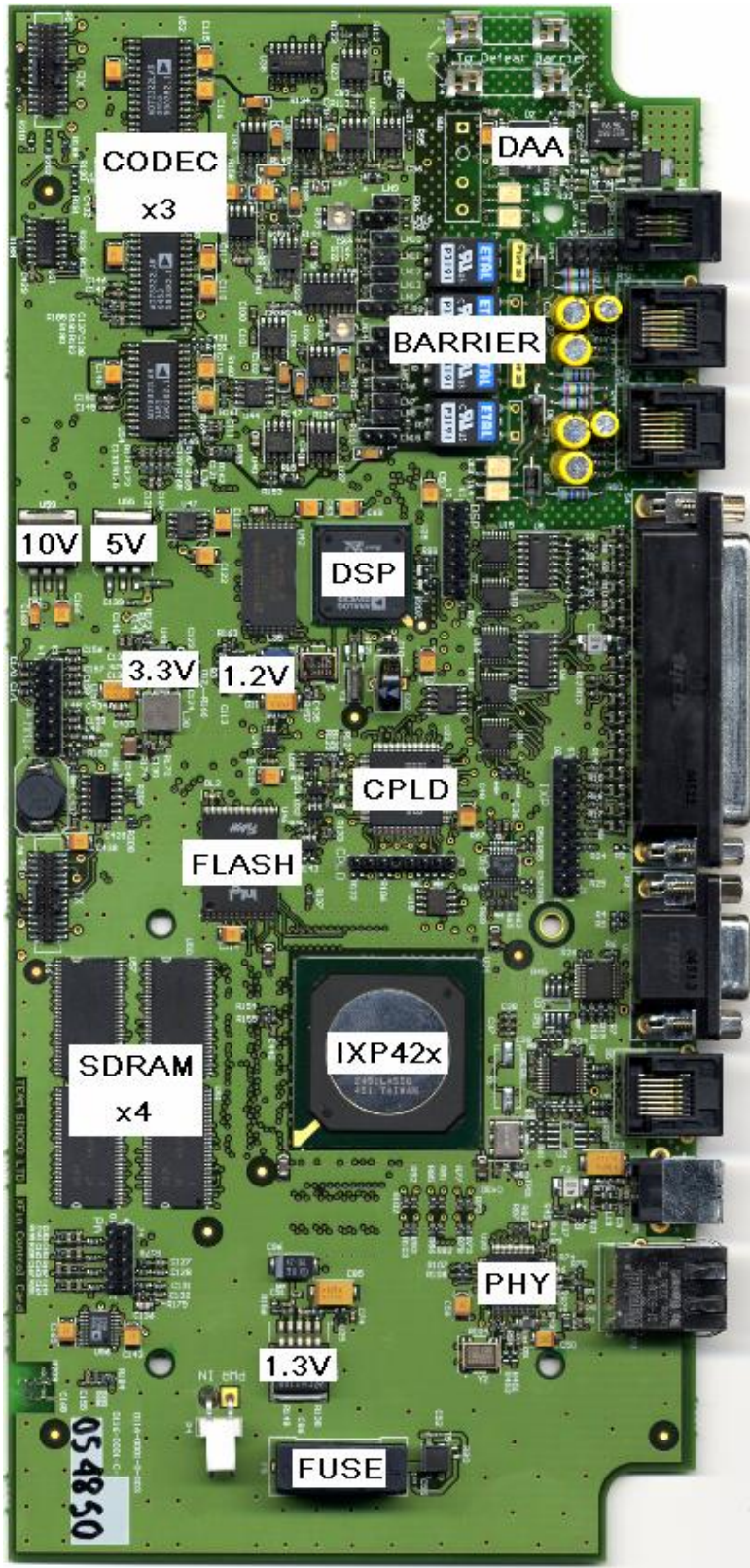

Figure 4.3 -
Control Board
Layout with Main
Sections Labelled

4.2.2 Circuit Description

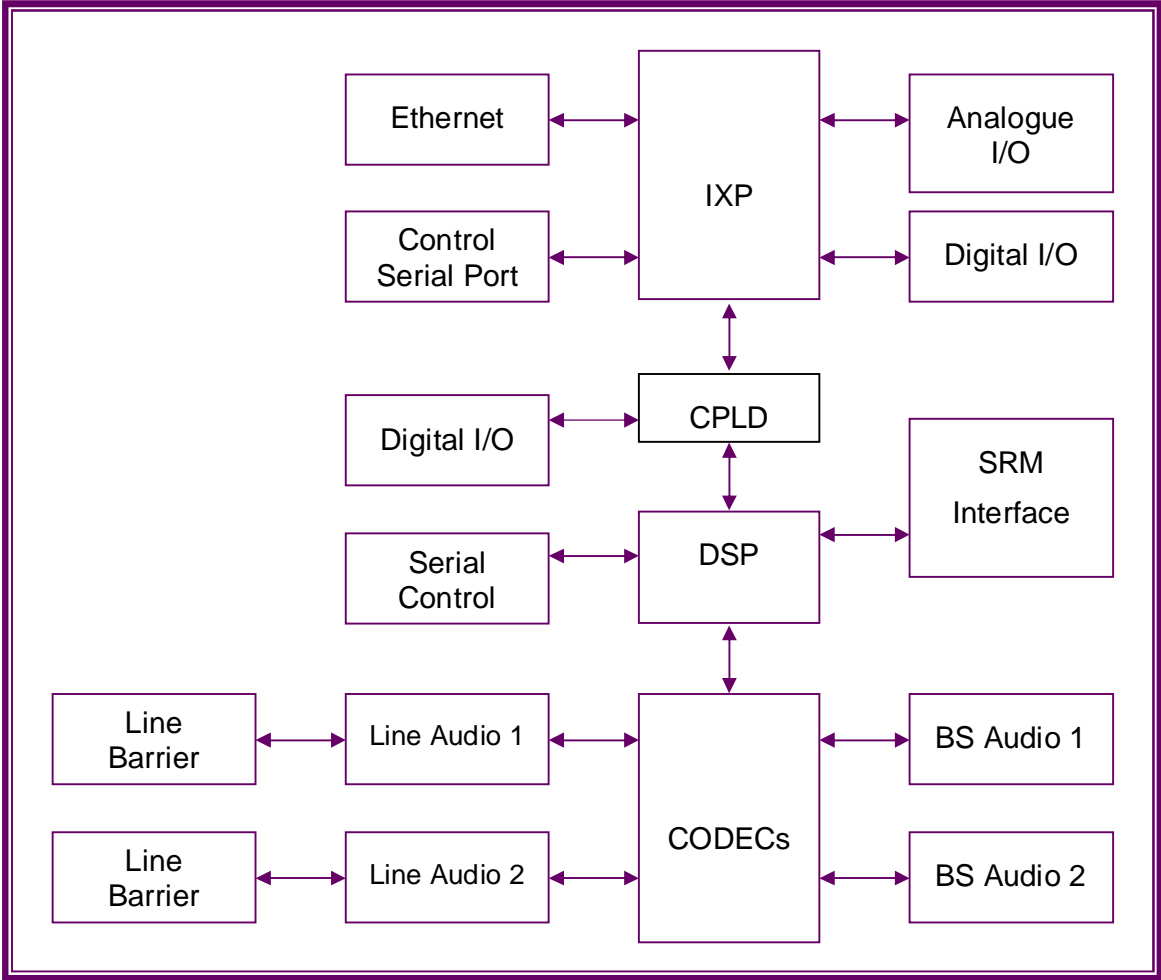

Figure 4.4 – Block Diagram of Control Board

See the Appendix for a more detailed block diagram representing the control card.

4.2.2.1 LEDs

LED DL1 indicates Ethernet connection (±INKq).

LED DL2 indicates the Flash device at U46 is being written to.

4.2.2.2 Test Points

Test Point	Monitors	Signal Type
1	Active-Low INVALID Pin on RS232 chip (U1)	3.3V Digital
2	Active-Low INVALID Pin on RS232 chip (U2)	3.3V Digital
3	Transmit Centre-Tap on Magnetic RJ45 (P3)	D.C.
4	Output 4 of Clock Driver (U12) Bank B	Clock Signal
5	Inverted Output of Digital I/O Shift Register (U10)	3.3V Digital
6	Inverted Output of Digital I/O Shift Register (U17)	3.3V Digital
7	Inverted Output of Digital I/O Shift Register (U11)	3.3V Digital
8	Output 4 of Clock Driver (U12) Bank B	Clock Signal
9	DSP PF10	3.3V Digital
10	IXP_IRQA output from CPLD (U22)	3.3V Digital
11	IXP_CLK_CPLD Signal to CPLD (U22)	Clock Signal
12	IXP_IRQB output from CPLD (U22)	3.3V Digital
13	GPIO_IN4 Signal to CPLD (U22)	3.3V Digital
14	Feedback to Clock Driver (U12)	Clock Signal
15	SPI_MISO signal to IXP GPIO(2)	3.3V Digital
16	TX_DATA signal for High Speed Serial Port 1 on the IXP (U34)	3.3V Digital
17	RX_CLK signal for High Speed Serial Port 0 on the IXP (U34)	3.3V Digital
18	SPI_CS_ADC signal from IXP GPIO(9)	3.3V Digital
19	GPIO_IN7 Signal to CPLD (U22)	3.3V Digital
20	IXP_RD_N Signal to CPLD (U22)	3.3V Digital
21	I ² C CLK (SCL)	3.3V Digital
22	SPI_CS_DS from IXP GPIO(3)	3.3V Digital
23	RX_DATA signal for High Speed Serial Port 1 on the IXP (U34)	3.3V Digital
24	RTS for DSP Serial Port from DSP PF3	3.3V Digital
25	Off-Hook signal OH_N from DSP PF8	3.3V Digital
26	SPI_CS_DM	3.3V Digital
27	Spare I/O Pin CIO2 on CPLD (U22)	3.3V Digital
28	JTAG TDO Signal from CPLD (U22)	3.3V Digital
29	TX_FRAME signal for High Speed Serial Port 1 on the IXP (U34)	3.3V Digital
30	TX_CLK signal for High Speed Serial Port 0 on the IXP (U34)	3.3V Digital
31	RX_CLK signal for High Speed Serial Port 1 on the IXP (U34)	3.3V Digital

32	PF1 on the DSP (U28)	3.3V Digital
33	I ² C Data (SDA)	3.3V Digital
34	RX_FRAME signal for High Speed Serial Port 1 on the IXP (U34)	3.3V Digital
35	Active-Low RING signal (indicating half-wave ringing detect output signal) from PSTN interface (U7)	3.3V Digital
36	GPIO_IN6 Signal to CPLD (U22)	3.3V Digital
37	SPI_CS_DAC from IXP GPIO(10)	3.3V Digital
38	RX_FRAME signal for High Speed Serial Port 0 on the IXP (U34)	3.3V Digital
39	TX_CLK signal for High Speed Serial Port 1 on the IXP (U34)	3.3V Digital
40	RX_DATA signal for High Speed Serial Port 0 on the IXP (U34)	3.3V Digital
41	DSP Memory Select DSP_AMS3_N to CPLD (U22)	3.3V Digital
42	Spare I/O Pin CIO3 on CPLD (U22)	3.3V Digital
43	TDI JTAG Signal to CPLD (U22), connected to IXP GPIO(11)	3.3V Digital
44	TX_FRAME signal for High Speed Serial Port 0 on the IXP (U34)	3.3V Digital
45	DSP_IRQA output from CPLD (U22)	3.3V Digital
46	GPIO_IN5 to CPLD (U22)	3.3V Digital
47	TMS JTAG Signal to CPLD (U22)	3.3V Digital
48	TX_DATA signal for High Speed Serial Port 0 on the IXP (U34)	3.3V Digital
49	ENET0_INT_N to IXP GPIO(4)	3.3V Digital
50	Audio Output 1 from Codec C2 (U52) after passing through the 1 st Op-Amp stage	Audio Signal
51	DSP_IRQB output from CPLD (U22)	3.3V Digital
52	TCK JTAG Signal to CPLD (U22)	3.3V Digital
53	CPLDI_CS_N	3.3V Digital
54	DSP_IRQA output from CPLD (U22)	3.3V Digital
55	GPIO_IN3 to CPLD (U22)	3.3V Digital
56	GPIO_IN2 to CPLD (U22)	3.3V Digital
57	Audio Input 2 to Codec C2 (U52) prior to being converted from single-ended to differential	Audio Signal
58	IXP Write Strobe IXP_WR_N	3.3V Digital
59	Active-Low Global Reset	3.3V Digital
60	Anti-Aliasing Filter Selector, generated by DSP PF11	3.3V Digital
61	SPI_MOSI generated by IXP GPIO12	3.3V Digital

62	Audio Input 1 to Codec C2 (U52) prior to being converted from single-ended to differential	Audio Signal
63	SPI_CLK	3.3V Digital
64	5V Bias for 10V Op Amps	D.C.
65	Audio Output 2 from Codec C2 (U52) after passing through 1 st Op-Amp stage	Audio Signal
66	Analogue 3.3V A3V3	D.C.
67	Analogue Ground AGND	D.C.
68	Analogue 2.5V Supply Rail (Bias for 5V Op Amps and ADC) A2V5	D.C.
69	Codec Select Strobe CODSE generated by DSP PF4	3.3V Digital
70	Digital 5V supply rail (used by 3.3V Switched Mode Power Supply) 5V0D	D.C.
71	Analogue 5V Supply Rail (used by ADC and 5V Op Amps) A5V	D.C.
72	Codec Reset CODRST_N generated by DSP PF5	3.3V Digital
73	Digital Ground DGND	D.C.
74	Pin 23 of P5 Rx Radio Header	
75	Pin 21 of P5 Rx Radio Header	
76	Pin 3 of P5 Rx Radio Header	
77	I2C Data (I2C_SDA)	3.3V Digital
78	Analogue 2.5V Supply Rail (Bias for 5V Op Amps and ADC) A2V5	D.C.
79	Digital Ground DGND	D.C.
80	Pin 23 of P6 Tx Radio Header	
81	Pin 21 of P6 Tx Radio Header	
82	Pin 3 of P6 Tx Radio Header	
83	TX_PTT inputted to DSP PF15	3.3V Digital
84	I ² C CLK (SCL)	3.3V Digital
85	Pin 20 of P5 Rx Radio Header	
86	3.3V Digital Voltage Supply 3V3	D.C.
87	RX_EXTOUT inputted to DSP PF9	3.3V Digital
88	Pin 6 of P6 Tx Radio Header	
89	Digital Ground DGND	D.C.
90	PSTN Tx+	Audio Signal
91	Network Processor Oscillator Tri-State Enable	3.3V Digital
92	PSTN Rx-	Audio Signal
93	PSTN Tx-	Audio Signal

94	PSTN Rx+	Audio Signal
95	Auxiliary Audio Rx	Audio Signal
96	Auxiliary Audio Tx	Audio Signal
97	Mic Rx	Audio Signal
98	Speaker Tx+	Audio Signal
99	Speaker Tx-	Audio Signal
100	Handset Rx	Audio Signal
101	Handset Tx	Audio Signal
102	10V Voltage Supply	D.C.
103	3.3V Digital Voltage Supply	D.C.
104	Codec 0, Output 1 (Positive)	Audio Signal
105	1.3V Digital Voltage Supply 1V3	D.C.
106	Filtered Input Voltage Supply VIN _F	D.C.
107	Input Voltage Supply VIN	D.C.
108	1.2V Digital Voltage Supply 1V2	D.C.
109	3.3V Analogue Voltage Supply	D.C.

4.2.2.3 DSP

The DSP on the Xfin control card is a Blackfin device manufactured by Analog Devices; it runs at speeds of up to 500 MHz. The DSP is responsible for all audio processing including mixing, FFSK encoding/decoding, DTMF encoding/decoding, supervisory tone generation, audio emphasis and speech processing for VOIP between Blades.

Booting

The DSP downloads the application code from the IXP Network Processor at start up and runs the software entirely in internal memory.

RS232 Serial Interface (Rear RJ-45)

The rear of the Blade contains a standard RJ-45 Serial connection in order that an engineer may connect a PC to the DSP via an RJ-45 to DB-9 cable. Debug commands may then be issued to the DSP for diagnostic information.

CPLD Interface

Communications between the IXP Network Processor and the DSP are performed by connecting the data bus on the IXP to the host interface (Lattice LC256V-75T100 CPLD) connecting to the DSP. The IXP writes to the host interface, triggering a DMA on the DSP to copy the data to a buffer. After a packet has been sent, the DMA on the DSP copies data from an outgoing buffer to the host interface port that is read by the IXP. This enables high-speed communications without impacting the performance of the DSP.

4.2.2.4 Power

The control board requires a 12V 2000ma supply. Linear regulators are provided to reduce the input voltage down to 10V and 5V for the audio circuits. The input voltage supply is also regulated down to 3.3V for the digital logic via a switched mode power supply. The 1.3V supply for the IXP processor core is generated by a regulator off the 3.3V rail. The 1.2V supply for the DSP core is generated by a diode (controlled by the DSP) off the 3.3V rail.

4.2.2.5 IXP

Description

The main processor is an IXP42x processor manufactured by INTEL. It consists of a central ARM based processor supported by separate network processor engines for supporting the Ethernet and USB ports. The IXP runs the application code under MontaVista Linux. The application code consists of Trunked Site Control, Inter-Blade Communications, Site Configuration, Fan Control and the LCD menu system.

The network processor also provides support to the DSP. The IXP is connected to external flash memory that stores the IXP software. Reset of the IXP is performed reset circuitry monitoring voltage supplies.

Watchdog

The IXP processor has its own internal watchdog.

Fan Control

The IXP performs fan control via Maxim Fan Regulator devices, monitoring the temperature of the airflow from the transmitter module using a thermistor (RT1). If the temperature is too high or low, the speed of the fans is adjusted accordingly. Fans are not allowed to stop during normal operation. Each fan generates a tachometer output allowing software to detect a fan failure or potential failure by monitoring fan speed. If one fan fails the speed of the second fan will be increased to compensate.

Analogue Outputs

Two analogue outputs are provided by a dual-channel Digital to Analogue Converter (U41). They provide analogue outputs to the Facilities Connector to output, for example, the RSSI level.

Analogue Inputs

The ADC (U56) has eight analogue inputs available, which are currently used to provide voltage monitoring of the thermistor and the 12V unregulated supply, receive inputs from the PA header and provide feedback of the analogue outputs.

Digital I/O

A set of shift registers (U10, U11, U15, U16 and U17) is controlled by the IXP via the CPLD to provide digital I/O to the Facilities Connector as well as internal controls.

Ethernet interface

The IXP controls an LXT971 PHY chip (U20) that provides a 10/100 Base-T Ethernet interface. The PHY is connected to an RJ-45 socket with built-in magnetics; the socket also presents two external LEDs which are configured to indicate activity and 10/100 status.

RS232 Serial Interface (DB-9)

The rear of the Blade contains a standard 9-way Serial connection in order that a straight through cable may be used to connect a PC to the IXP.

UART Serial Interfaces (Front Panel RJ-45)

The IXP presents a serial port interface to the RJ-45 port in the front panel.

4.2.2.6 CoDec

Audio received from either or both of the line ports and the PSTN interface is fed into a chain of 3x AD73322L codecs (U52, U53 and U54) that is connected to the DSP via its SPORT (Serial PORT) interface serial link.

The DSP performs audio signalling to the line equipment or patches the audio to the radio module.

Handset audio is fed via a codec (U53) into the DSP allowing it to be mixed to line or the radio modules under software control. Audio is also fed to the speaker on the front panel.

The codec contains built-in analogue gain adjustment under software control.

4.2.2.7 Audio Interface

General

External audio equipment is connected to either of the two independent audio ports which are presented barriered on the RJ45 connectors, and un-barriered on the 37-way Facilities Connector.

Two and Four Wire

The barriered connections are link selectable as either two or four wire. In two-wire mode the balance of the hybrid can be set manually by moving LN18 (LN16 for port 2) to position 2-3. If a test tone is generated to line, the reflected audio can be monitored on TP57 (TP62 for port 2) and variable resistor R128 (R135 for port 2) can be adjusted to give the minimum level.

At the time of configuration, the audio levels of the line ports must be set for optimal performance. In line-to-air mode, it must be possible for a -10dBm signal to generate a 2.5kHz (full-scale) deviation. In loopback mode, an undistorted signal up to -10dBm should be re-outputted with unity gain; this can be configured by inputting a -14.4dBm signal (equivalent to 1.5kHz/60% deviation over air) into the line port and altering the gain level until an equivalent -14.4dBm signal is seen at the output.

E & M

The control board contains opto-isolated digital inputs (U9, U14) and outputs (U8, U13). In order to support local connections where an external bias voltage is not present, Fuse-

links F3 and F4 can be fitted to provide bias volts. This allows the unit to use DC signalling.

4.2.2.8 PSTN Interface

A Clare DAA chip (U7) provides a PSTN interface. An audio channel links the telephone port to a codec (U54).

At the time of configuration, the audio levels of the PSTN interface should be set for optimal transmission and reception.

PSTN Interface Specifications:

Isolation Characteristics	3000 Vrms rated isolation voltage; 2000V/ s rated surge rise time.
Continuous Output Current	130 mA (max where $R_{zdc} = 8.2 \Omega$).
Ringling Signal Detect Level	5 Vrms (min for 68Hz applied to tip and ring); 28 Vrms (min for 15Hz applied across tip and ring).
Frequency Response	30 to 4000Hz (166Hz to 4000Hz for Snoop Circuit).
Ringer Equivalence	0.01B REN.
Return Loss	26 dB (typical, into 600 Ω at 1800Hz).
Insertion Loss	-0.4dB to 0.4dB (Tx and Rx, 30 to 4000Hz).
Tx/Rx Level	2.2Vp-p (max) for a single-tone sine wave.

4.2.3 Links

For Fuse Links F3 and F4, see E & M above.

Link		Remarks	Default
LN1	In	Line 2 M-Wire bias GND - requires F3 fit	
	Out	No bias - barrier is not breached	✓
LN2	In	Line 1 M-Wire bias GND - requires F3 fit	
	Out	No bias - barrier is not breached	✓
LN3	In	Line 2 E-Wire +V Bias (input supply volts) - requires F4 fit	
	Out	No bias - barrier is not breached	✓
LN4	In	Line 1 E-Wire +V Bias (input supply volts) - requires F4 fit	
	Out	No bias - barrier is not breached	✓
LN5	In	Capacitor link for Line 1 UK Complex Impedance Select	
	Out		✓
LN6	In	Line 1 Four-Wire RX Impedance Enable	✓
	Out	Line 1 Two-Wire	
LN7	In	Line 1 UK Complex Impedance Select	
	Out		✓
LN8	In	Line 1 Two-Wire 600R Impedance select	
	Out		✓
LN9	In	Line 2 Complex Impedance Hybrid Balance	
	Out		✓
LN10	In	Capacitor link for Line 2 UK Complex Impedance Select	
	Out		✓

Link		Remarks	Default
LN11	In	Line 2 Two-Wire 600R Impedance select	
	Out		✓
LN12	In	Line 2 UK Complex Impedance select	
	Out		✓
LN13	In	Line 2 Four-Wire RX Impedance Enable	✓
	Out	Line 2 Two-Wire	
LN14	In	Line 2 Complex Imped. Hybrid Balance	
	Out		✓
LN15	1 - 2	Line 1 Four-Wire Mode	✓
	2 - 3	Line 1 Two-Wire Mode	
LN16	1 - 2	Line 2 Two-Wire 600R Imped. Hybrid Balance	✓
	2 - 3	Line 2 Adjustable Hybrid Balance	
LN17	1 - 2	Line 2 Four-Wire Mode	✓
	2 - 3	Line 2 Two-Wire Mode	
LN18	1 - 2	Line 1 Two-Wire 600R Imped. Hybrid Balance	✓
	2 - 3	Line 1 Adjustable Hybrid Balance	

Note: Unless specifically ordered otherwise, the Control Board is supplied in the default configuration shown in this table.

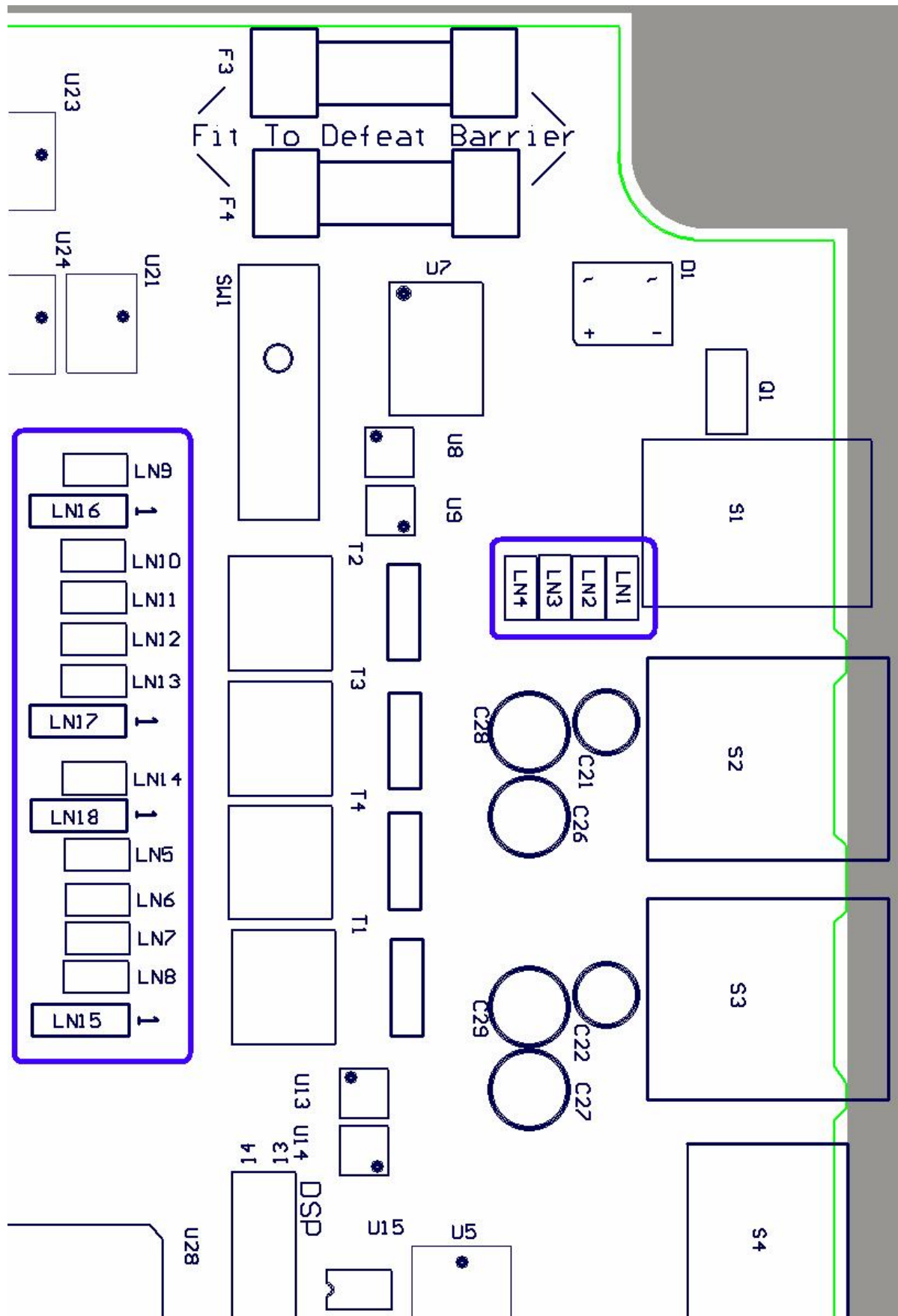

4.3 RECEIVER AND TRANSMITTER MODULES

4.3.1 Frequency Bands

The Blade is supplied with a matched pair of radio sub-assemblies fitted.

The designated frequency bands are:

66 - 88	MHz	E0 Band	335 - 375	MHz	R1 Band
136 - 174	MHz	AC Band	400 - 450	MHz	TK Band
174 - 208	MHz	K1 Band	400 - 480	MHz	TU Band
208 - 245	MHz	KM Band	440 - 500	MHz	UW Band
310 - 350	MHz	R0 Band	470 - 530	MHz	WR Band

The following text refers to the components and circuits within the RF sub-assemblies only. For additional information, refer to the SRM9000 Service Manual [1].

The Rx and Tx Modules are equivalent and interchangeable for a given power classification (25W or 100W). They are connected to the Control Board via a 26-way Ribbon Cable that carries analogue audio, digital audio and control signals.

Power connections are made via a 15-way, D-type connector and RF connections are made via BNC sockets. RF connections are taken to the rear of the Blade via double-screened cables terminated with female N-types.

4.3.2 Receiver

Refer to Figure 3.5.

4.3.2.1 Front-end Filters and Rx Front-end Amplifier

The receiver input signal from the antenna passes through the antenna filter comprising L10, L11, L12 and associated tuning capacitors. With a transceiver module in receive mode, diodes D3, D4 and D5 in the antenna switch are reverse biased allowing the receiver input signal to be coupled through to the front-end with minimal loss. The overall insertion loss of the antenna filter and switch is approximately 0.8dB.

Front-end selectivity is provided by varactor tuned bandpass filters at the input and output of the RF amplifier.

Front-end tuning voltages are derived from the alignment data stored in the radio. The DSP processes this data to optimise front-end tuning relative to the programmed channel frequencies that may be changed at any time without re-aligning the radio.

To achieve the required varactor tuning range an arrangement of positive and negative bias power supplies is used to provide a total bias across the varactors of up to 14.0VDC. A fixed 2.5V positive bias derived from the 5.0V supply and voltage divider R425/426 is applied to the cathodes of the varactor diodes. The negative bias supply originates at the DSP/FPGA as a composite digital tuning signal (FE TUNE) containing the data for the four front-end tuning values TUNE 1 to 4 for the particular channel frequency selected. The level is dependent on channel frequency and tuning and varies between +0.1 and +3.0V. This signal then passes through buffer U901A and level translator Q900 to Q903 where it is converted to a high level (-0.5 to -11.5V) negative equivalent of the original signal.

The -12.0V rail of the level translator is generated by U300B/C with D304 to D306 providing the required voltage multiplier effect. The high level negative signal is then split into the four individual front-end negative DC values under software control by multiplexer U902 and associated storage capacitors C904 to C907 before being applied to the anodes of the front-end tuning varactors.

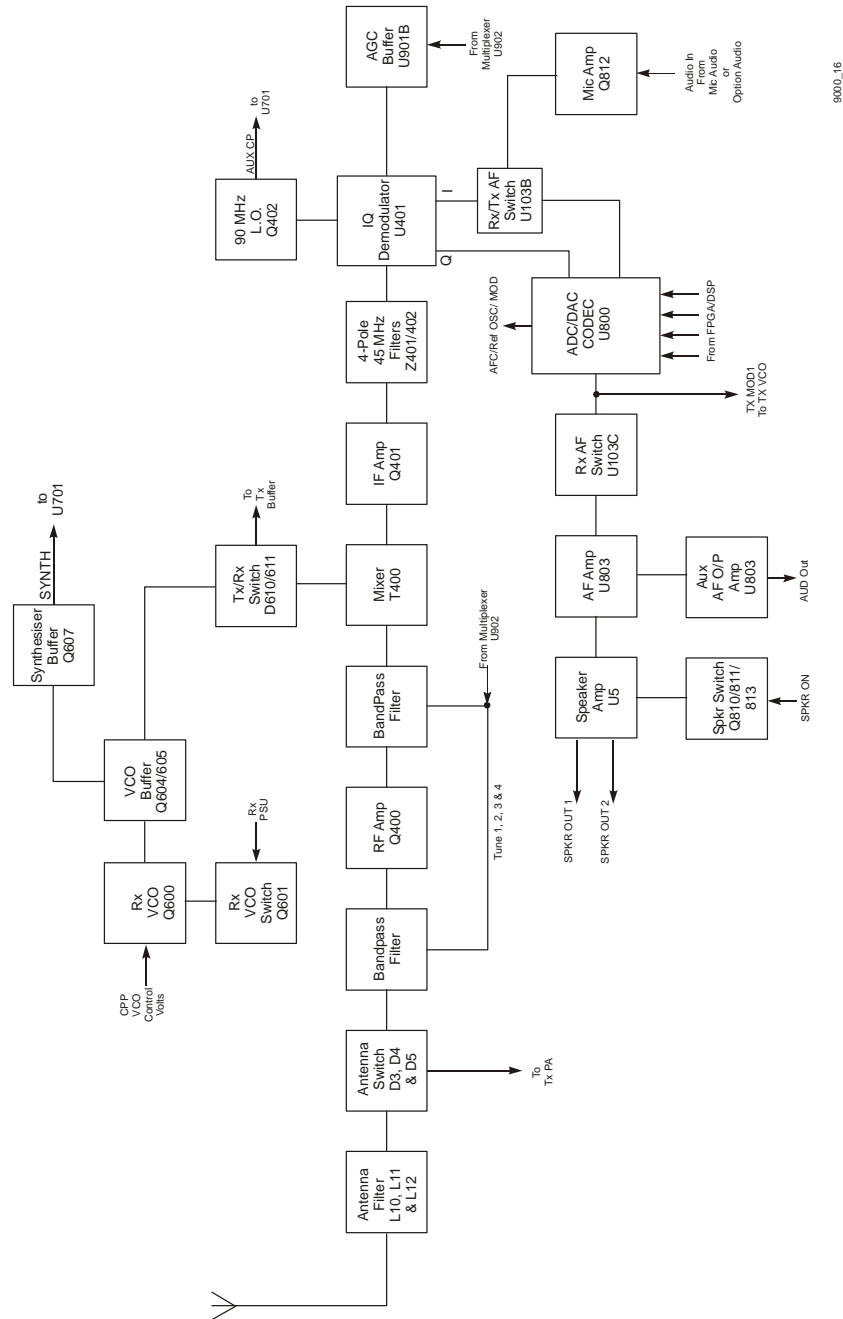

Figure 3.5 - VHF/UHF Receiver Block Diagram

The RF front-end amplifier stage comprises a low-noise transistor amplifier (Q400), which is compensated to maintain good linearity across the required frequency bands and temperature range. This provides excellent intermodulation and blocking performance across the full operating range. The gain of this stage is typically 17dB for both UHF and VHF versions.

4.3.2.2 First Mixer and IF Section

The output of the last front-end bandpass filter is coupled into single balanced mixer T400/D413 which converts the RF signal to an IF frequency of 45MHz.

The local oscillator injection level is typically +8dBm at T400 pin 1 with low side injection used for UHF and high side for VHF. Following the mixer is IF amplifier Q401 which provides approximately 15dB of gain and in association with its output circuitry presents the required load conditions to the 4 pole 45MHz crystal filter Z401/402.

4.3.2.3 Quadrature Demodulator

Additional IF gain of approximately 30dB occurs at U401, which is a dedicated IF AGC amplifier/Quadrature, Demodulator configured for single-ended input and output operation.

The AGC voltage for U401 is derived from the RSSI function of the DSP via AUX CTL and multiplexer U902. The onset of AGC operation occurs when RF input signal levels at the antenna exceeds -90dBm. Conversion of the 45MHz IF signal to I and Q baseband signals is carried out by the demodulator section of U401. The 90MHz local oscillator signal is generated by VCO Q402 which is phase locked by the auxiliary PLL output of U701 via feedback signal AUX LO2.

4.3.2.4 Receiver Audio Processing

All receiver audio processing and filtering functions are performed by the CODEC U800 under the control of the DSP.

The receiver I and Q analogue baseband signals are converted to digital signals by the CODEC ADC before being applied to a series of digital filters which provide the final stage of adjacent channel filtering, high pass and low pass filtering and mute noise processing for narrow and wideband operation. The processed signals are then converted to analogue audio signals by the CODEC DAC and are applied to conventional audio amplifiers U803A/B and the speaker amplifier U5.

The speaker circuits are not used in the Blade. The carrier and signalling mute functions are performed by Q810/811/813 under DSP control with additional receiver muting to U803B being applied by U103C when the mobile is in transmit mode.

Flat audio (20Hz . 5.8kHz) is provided to S1-6 via amplifier U803A. De-emphasis is performed on the Control Board.

Software functions are used to filter off signals below 300Hz and above 3kHz.

4.3.3 Transmitter

Refer to Figure 3.6.

4.3.3.1 Drivers and PA Stages

The RF output level from the VCO buffer Q604 is typically +5dBm (UHF) and +8dBm (VHF). TX buffer Q606 increases this level by approximately 3dB (UHF) and 11dB (VHF) and also provides additional VCO isolation.

The following section of the TX buffer Q612 is controlled by the transmitter power control loop and Q609. Q609 is normally saturated in transmit mode so there is no minimum gain control applied to this stage. The gain of Q612 is typically 10dB (UHF) and 15dB (VHF) but the output level is reduced by input and output resistive attenuators to limit the PA driver input level to typically +20dBm. The gain of PA driver Q12 is controlled by the power control loop to ensure that transmitter output power remains within defined limits. The PA driver output level is typically +25dBm.

PA module U2 utilises three stages (UHF) and two stages (VHF) to achieve the required final RF output power level of +44dBm (25 watts). Power output settings are derived from alignment data stored in flash memory during the initial factory alignment. The DSP processes this data to optimise the power output level relative to the programmed channel frequencies which may be changed at any time without retuning the radio.

An active filter comprising Q14, 17,18 and 19 provides isolation to minimise power supply noise at the PA. This is achieved by maintaining a voltage differential of approximately 1V across Q14 and indirectly filtering its gate voltage. Q14 is switched on only during transmit via R523 to minimise receiver power requirements.

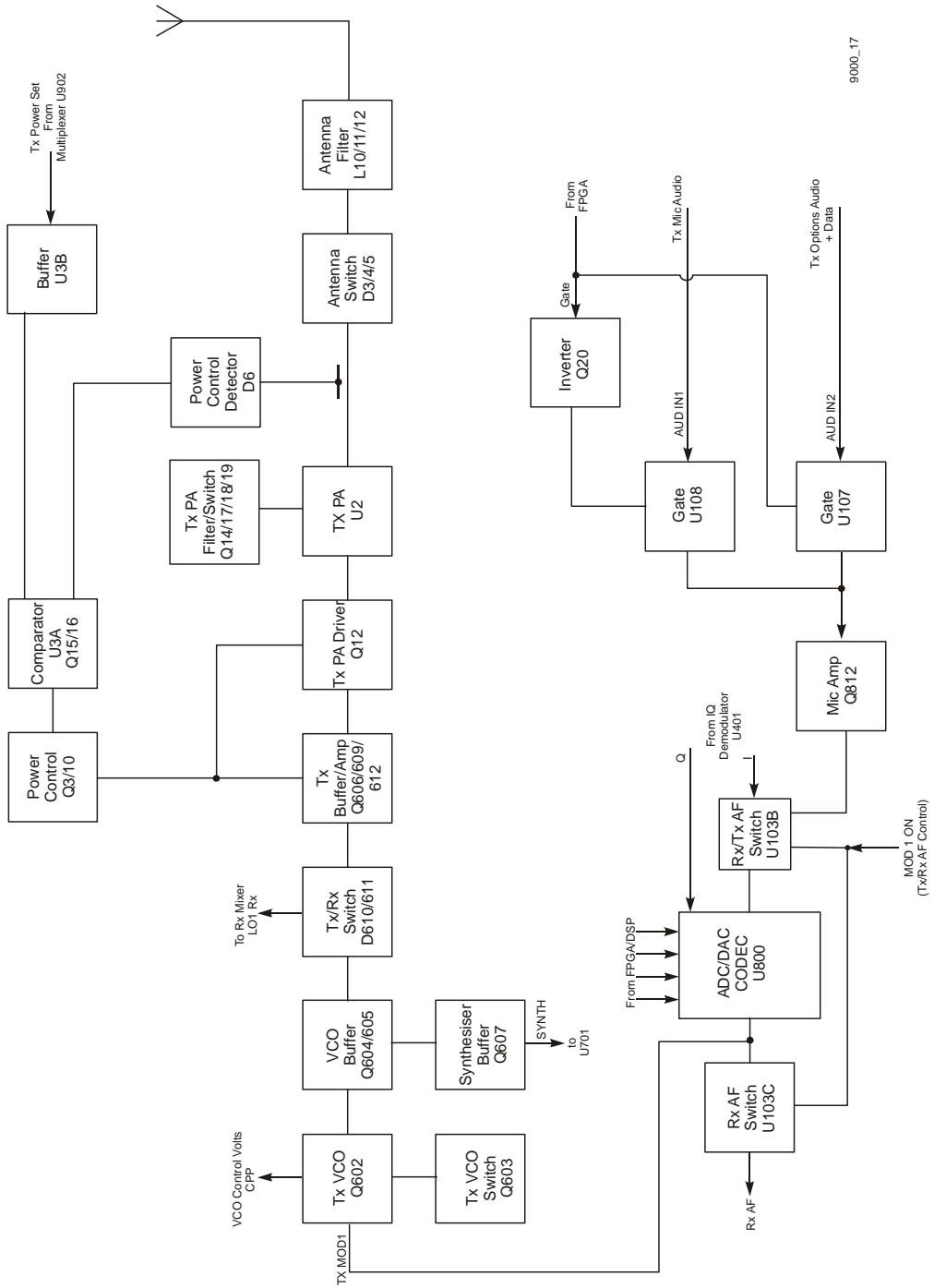

9000_17

Figure 3.6 - VHF/UHF Transmitter Block Diagram

4.3.3.2 Tx Power Control

Output power is stabilised by a power control feedback loop. L1, R54, a printed circuit transmission line, D6 and associated components comprise the power detector with Q3/Q10, U3 and associated components providing the power setting and control sections. Forward and reverse power is sampled by the power detector and applied as a DC voltage to the inverting input of comparator U3A. The TX PWR SET voltage, which is a DC voltage proportional to the programmed TX power setting, is applied to the non-inverting input of the comparator. PA module output level changes due to supply voltage, load or temperature variations are detected and applied to the comparator which proportionally adjusts the PA driver (Q12) supply, and therefore the PA drive level, via Q10/Q3. High temperature protection is provided by Thermistor R452 which progressively reduces the power level if the PA module temperature becomes excessive, approximately 86C case temperature. Q15 and Q16 provide for dual power control time constants necessary for good power ramp and decay characteristics.

4.3.3.3 Antenna Changeover and Harmonic Filter

The antenna changeover circuit consisting of pin diodes D3/D4/D5 is switched by Q4/Q8/Q11 and associated circuitry allowing the transmitter output to be coupled to the antenna while providing isolation for the receiver input. With the transmitter switched on, the diodes are forward biased allowing power to be coupled through to the antenna and isolating the receiver by grounding its input at C28. The short circuit at the receiver input is transformed to an effective open circuit at D3 by L13, which minimises transmitter loading. With the transmitter switched off the diodes are reverse biased allowing the receiver input signal to reach the receiver front-end with minimal loading and loss. The harmonic rejection low pass filter comprises L10/11/12 and associated capacitors.

4.3.3.4 Transmitter Audio Processing

Microphone audio input signals of 40mV RMS, with a source impedance of 470 ohms, are provided at the microphone input (AUD IN1) by the Control Board. Pre-emphasised flat-audio, (300Hz . 3kHz; 20Hz . 3kHz; or 20Hz . 5.8kHz) is provided to the transmitter by the Control Board via the 26-way ribbon cable. U108 is a control gate for the microphone audio signals.

AUD IN2 is the external audio options and data input used by the Blade Control Board. This is controlled by gate U107. Inverter Q20 ensures that the mic. audio is muted when the data or audio options signals are active. The AUD IN2 input level and source impedance is the same as the microphone input. Alternatively, the Blade can bypass the audio input circuits by sending a digital audio stream to the transceiver module.

Q812 is a unity gain amplifier that provides buffering of the audio and data signals. U103B provides CODEC input switching which selects either the receiver I signal or transmitter audio/data signals depending on the TX/RX mode. All pre-emphasis, filtering, compression and limiting processes for narrow and wideband operation are carried out in the CODEC (U800) under the control of the DSP. The processed transmitter audio/data from the CODEC output at VOUTL is applied to the VCO as a modulation signal with a level of approximately 200mV P/P.

4.3.4 Frequency Synthesis

4.3.4.1 General

Refer to Figure 3.7.

The SRM9000 frequency synthesiser consists of individual transmitter and receiver (local oscillator) voltage controlled oscillators, loop filter, varactor negative bias generator, reference oscillator and an integrated, dual phase locked loop device U701.

4.3.4.2 PLL

The PLL device contains two prescalers, programmable dividers and phase comparators to provide a main and auxiliary PLL. The main PLL of U701 controls the frequency of the TX/RX VCOs via Control Voltage outputs at pins 2 and 3 and VCO Feedback to pin 6. The auxiliary PLL is used to control the receiver 90MHz second local oscillator via the Control Voltage output at pin 17 and VCO Feedback to pin 15.

The PLL operation involves the division of the 14.4MHz reference oscillator frequency by divider U710 and the internal divider of U701 down to a lower frequency which corresponds to a sub-multiple of the radio channel spacing i.e. 6.25kHz for 12.5/25kHz channel spacing or 5kHz for 20kHz channel spacing. The VCO frequency is sampled and divided down to the same frequency after which it is phase compared to the reference. Any error produces an offset to the Control Voltage output which is used to correct the VCO frequency. A valid lock detect output is derived from pin 20 and is sampled by the FPGA during transmit. If an unlocked signal is detected the radio will switch back to receive mode.

4.3.4.3 VCO

The transmitter and receiver VCOs use low noise JFET transistors (Q600 RX, Q602 TX) and inductors L602 (RX), L608 (TX) to generate the signals for the required band coverage. Electronic tuning is provided by varactor diodes D600 to D608 with their control voltages derived from the Loop Filter, PLL and Negative Bias Generator. VCO selection and timing is controlled by the DSP via the RX and TX power supplies and applied through switches Q601 (RX) and Q603 (TX). VCO buffer Q604/605 isolates the VCO from load variations and active power supply filter Q615 minimises supply related noise. A PLL feedback signal is sampled from the VCO buffer output via buffer Q607.

4.3.4.4 Negative Bias Generator and Loop Filter

A positive and negative varactor bias supply similar to the front-end varactor arrangement has been used to achieve the required broadband tuning range of the VCOs. PLL device U701 is programmed to deliver a fixed nominal +2.5V output from phase detector/charge pump CPPF or CPP (selection depends on radio setup) regardless of the channel frequency selected. This voltage is filtered to remove synthesiser noise and reference products by loop filter C719/722/734 and R721/724/734. The resulting low noise voltage is applied to the cathode side of the VCO varactor tuning diodes as a positive bias voltage.

The negative bias supply originates as a positive DC voltage (0.1V to 3.0V) at the DAC output of U701 (DOUT) with a level relative to the programmed state of the radio (e.g.

channel frequency, TX/RX state). The voltage is converted to a high level negative supply by VCO Varicap Negative Supply Q700 to Q703. The -17V rail of this supply is generated by U300B/C with D304 to D307 providing the voltage multiplying effect needed to achieve -17V. The output of the negative supply is applied directly to the VCO varactor anodes as the negative tuning voltage VCAP BIAS.

4.3.4.5 Phase Modulator

The modulation path for audio, data and higher frequency CTCSS signals is via D609 and its associated components in the TX VCO. The reference input to the PLL (FXTAL) provides the low frequency modulation path in conjunction with phase modulator Q714 to Q716. U711A is a low pass filter that provides 6dB per octave attenuation to frequencies above approximately 180Hz. Modulation balance adjustment is carried out using a CODEC generated 100Hz square wave applied to TX MOD1. A DAC output from the Alignment Tool is applied to buffer U711B and ramp generator Q711 to Q713 via the TUNE BAL line to adjust the low frequency modulation level.

4.3.4.6 Reference Oscillator

TCXO U700 determines the overall frequency stability and frequency setting of the radio. The frequency setting is achieved by adjusting its ADJ voltage with the Alignment Tool. In addition, the ADJ input is used in a frequency control loop with the receiver I and Q signals to provide receiver AFC. U700 operates at 14.4MHz and is specified at ± 2.0 ppm frequency stability over the temperature range . 25C to +75C.

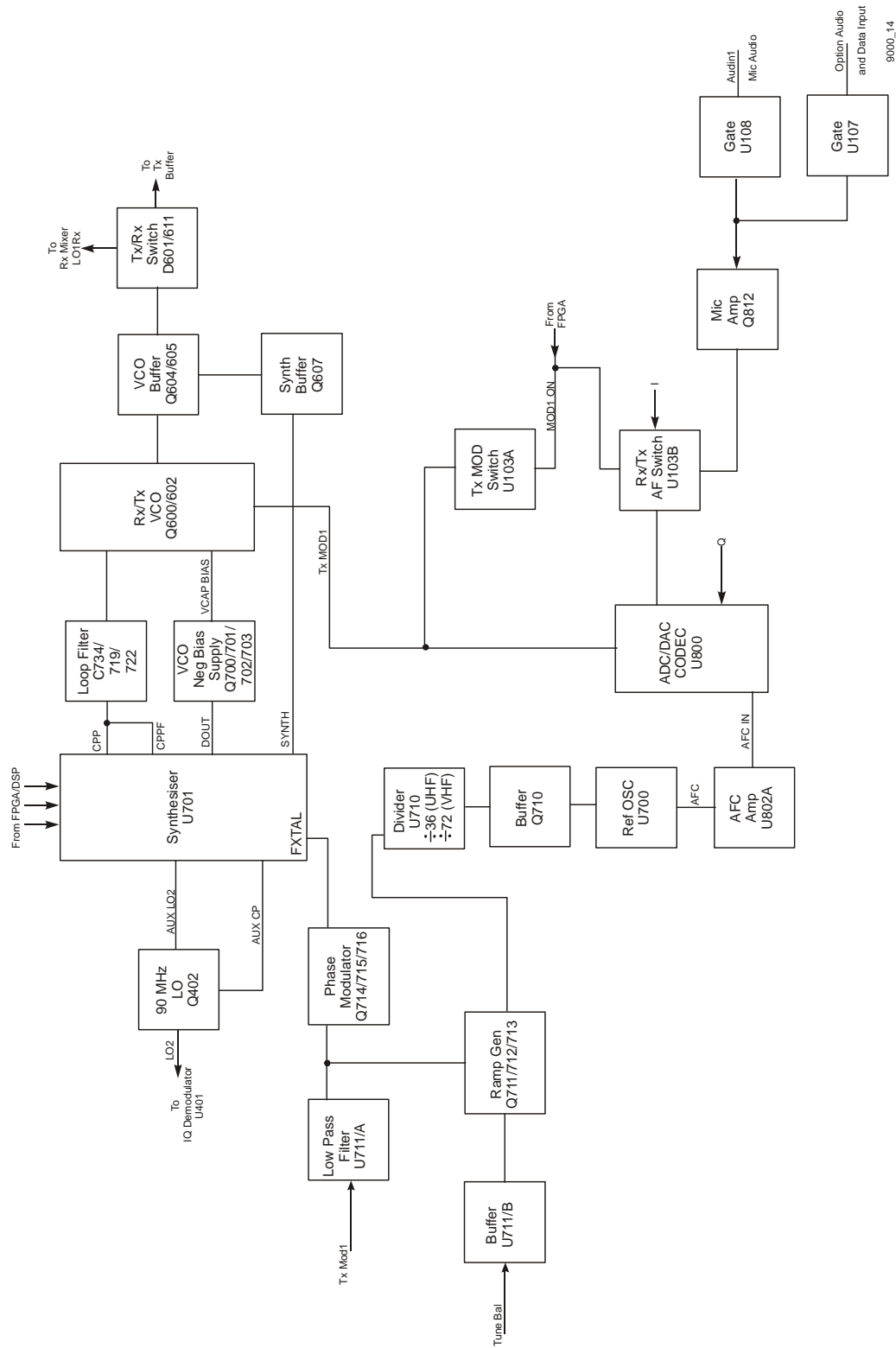
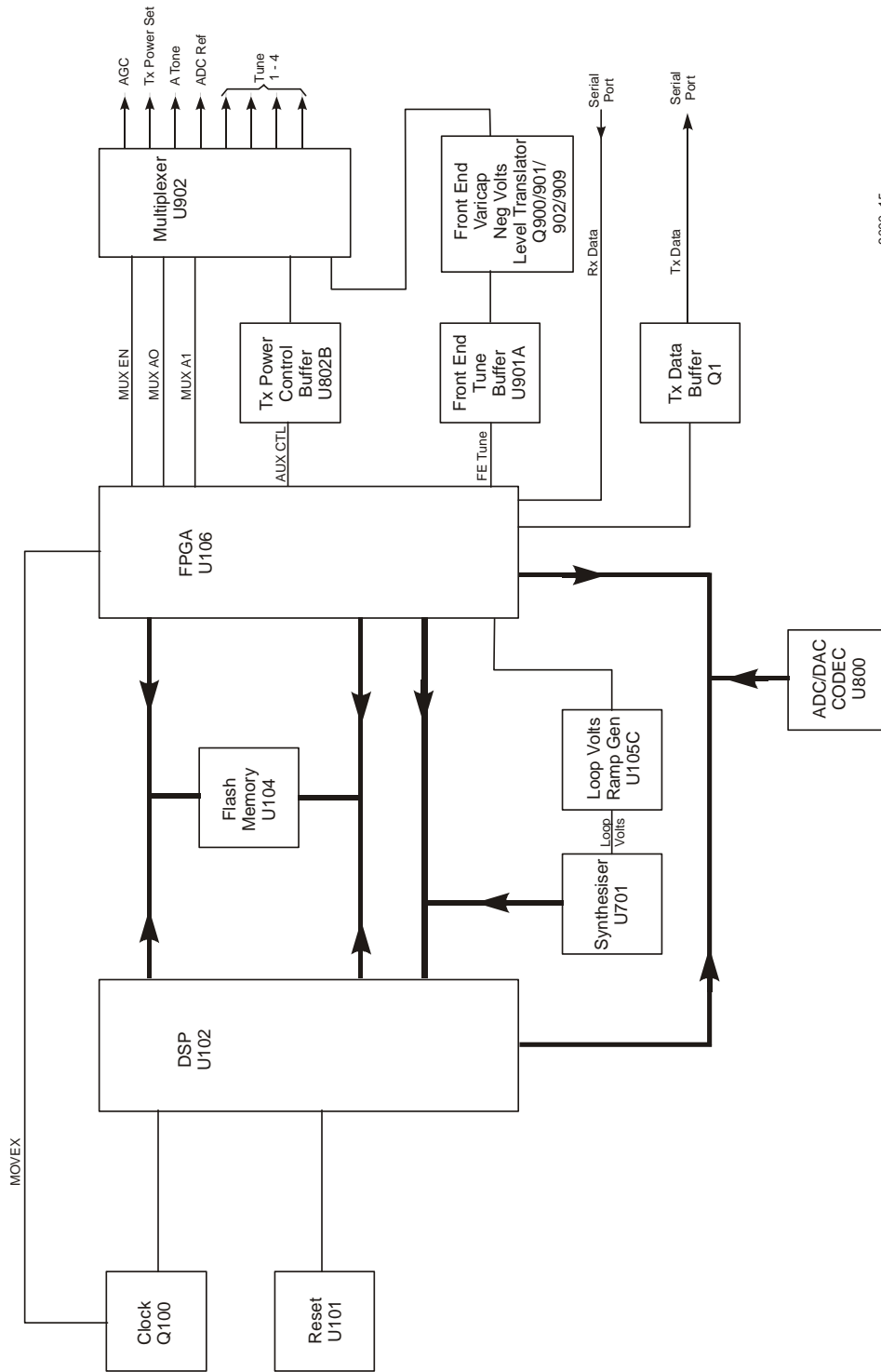

Figure 3.7 - VHF/UHF Synthesiser, Block Diagram

4.3.5 RF Sub-Assembly Internal Control Logic



9000_15

Figure 3.8 - VHF/UHF Control Block Diagram

4.3.5.1 DSP and FPGA

The Blade RF sub-assemblies operate under the control of a DSP (U102) and FPGA (U106) combination which together with a number of other dedicated devices perform all the operational and processing functions required by the radio. The FPGA is configured by the DSP under software control to provide the following functions:

- Channel set-up for operating frequency
- Modulation processing and filtering
- De-modulation processing and filtering
- TX power output reference
- Receiver front-end tuning
- Serial communications with control board
- Modem functionality for data modulation
- Embedded signalling / CTCSS generation and decoding
- CO control
- Receiver muting control
- TX / RX switching
- PLL detect

4.3.5.2 DSP Clock Oscillator

The DSP is clocked by a 15.360MHz oscillator that consists of crystal X100 and an internal DSP oscillator. Q100 forms a crystal switching circuit with C117 which when activated by a command from the FPGA steers the oscillator away from potential interfering frequencies.

4.3.6 RF Sub-Assembly Internal Memory

Memory consists of the internal DSP memory and an external 4MB non-volatile Flash Memory U104. When power is off, program and data is retained in Flash Memory. At power-on, a boot program downloads the DSP program from Flash Memory to its internal RAM for faster program execution and access to data.

4.3.6.1 Multiplexer

U902 contains 2 separate 4-channel multiplexers providing a total of 8 independently controlled analogue switches. Under software control, the multiplexers produce tuning voltages from supplied data for the receiver front-end (TUNE 1 to 4), TX power setting (TX PWR SET), receiver AGC (AGC-1), alert tone (A TONE) and FPGA ramp generator (ADC REF).

Buffer U802B is fed with a composite digital tuning signal (AUX CTL) from the DSP/FPGA containing the data for AGC, A TONE, ADC REF and TX PWR SET settings. The level is dependent on channel frequency and tuning and varies between 0.1 to 3.0V. This signal

is applied to one group of 4 analogue switches in U902 via a common input connected to pin 13. The second group of 4 switches is fed with the receiver front-end tuning signal FE TUNE (to provide outputs for TUNE 1 to 4) via the second common input at pin 3 as described in the receiver front-end section.

The 2 groups of analogue switches are independently controlled by FPGA binary signals MUX A0 and A1 and enable line MUXEN to output the required tuning voltages as a series of pulses. These pulses are converted to steady state voltages by integration capacitors C904 to 911 and C921 to 925.

4.3.7 RF Sub-Assembly Internal Power Supplies

4.3.7.1 Power On Function

This set of functionality is designed for normal use in a vehicle environment; hence much of it is unused in this product.

The unregulated 13.8V DC input is routed directly to high current devices and is also switched via FET Q350. The output from Q350 feeds three, low drop out series regulators and associated switched and auxiliary supplies that along with a negative voltage generator provide all the switched power requirements of the transceiver.

Q315/316/317 and U313 form a power on/off latch circuit that is activated by a pulse from the control unit or microphone/handset via PWR ON or PWR OFF and controls the FET power switch Q350. A PWR OFF operation requires the button to be held down for more than 2 seconds. This is then sensed by the FPGA via the PWR SENSE line that turns the radio off by placing a positive pulse on the PWR OFF line thereby resetting U313B.

4.3.7.2 Power Lines

The following is a list of the internal RF Sub-Assembly's power supplies and some of the devices and circuits they supply.

+8V Regulator U310

Regulated +8.0V supply (8V0 and +8V)

- TX buffer Q612
- VCOs and VCO buffers via active filter Q615
- RX second local oscillator via Q403

Regulated +8.0V switched supply (RX PSU)

- RX front-end
- IF Amplifier
- Various switching functions

+5V Regulator U311

Regulated +5.0V supply (5V0 and +5V)

- RX front-end varactor positive bias
- Synth. buffer Q607
- VCO varactor negative supply Q700 to Q703
- TCXO U700
- RX audio amplifiers U803A/B

- RX mute switch Q810/813
- Multiplexer U902
- FE TUNE level translator and buffer U901A, Q900/901

Regulated +5.0V switched supply (TX PSU and TX PSU+)

- TX power control U3
- TX buffer Q606
- Microphone amplifier Q812
- Various switching functions

+3.3V Regulator U312

Regulated +3.3V supply (3N3)

- Digital supply for CODEC U800
- DSP U102
- FPGA U106

Regulated +3.3V supply (3Q3)

- I Q demodulator U401

Regulated +3.3V supply (3C3)

- Analogue supply for CODEC U800

Regulated +3.3V supply (3P3)

- PLL U701
- TCXO divider U702

Unregulated 13.8V (13V8 UNSW)

- TX PA module U2
- TX PA power control circuit Q3
- Active filter Q14/17/18/19
- Antenna changeover switch Q4/8/11
- RX mute switch Q811
- RX speaker amplifier U5

Negative Power Supply U300B/C

Provides -17.0V output (-17V0)

- Negative rail for VCO Varicap Negative Supply Q700, 701, 702 and Q703

-12.0V Output (-12V0)

- Negative rail for FE TUNE level translator Q900, 901, 902, 903 and multiplexer U902

4.4 ANTENNA REQUIREMENTS

The antenna connections on the Blade are provided with 50Ω female N-type sockets. These should be tested, by use of a suitable test set, e.g. Anritsu/Wiltron S331A, for good VSWR (1.5:1 or better) at the Tx and Rx frequencies prior to use.

Mating connectors should be galvanically compatible with nickel outer and gold centre pin to minimise passive intermodulation.

A minimum of 85dB transmit-receive isolation should be provided by the antenna system and associated filters.

4.5 POWER SUPPLIES

For type approval reasons, this product should not be operated with un-approved supplies.

The switch mode supplies used in the wall mount and rack mount ancillaries are able to accept main AC in the range of 100 to 240 V, 50 or 60Hz. The output from the switched mode power supply to the Blade is +13.6VDC.

Pin 3 on the D-type Power Connector provides protective earthing on the equipment. This should be connected using heavy duty Green/Yellow earthing wire, capacity greater than mains feed to equipment, as few bends as possible and an appropriate eyelet tag.

Mains protective Earth should be checked for low impedance ($<0.3\Omega$).

The equipment must be installed so that the IEC connector for the Wall or Rack Mount can be easily removed and/or the power socket should be readily accessible.

All mains wiring must comply with local wiring regulations.

4.6 CONFIGURATION

Configuration is provided via file download. This is performed via the XBMT Programmer using a PC connected to the Xfin Control card via its Ethernet port. Files are then stored in the product in non-volatile memory.

Editing of parameters on a live base station is also possible with a connected PC.

4.7 ADJUSTMENT AND ALIGNMENT

The two RF modules within this product are based upon the RF card of an SRM9000 mobile. The set up and alignment procedures for SRM9000 should be followed. In the event of a level-3 repair being required, refer to the SRM9000 Service Manual (TSD-SRM9000-SM) [1].

There are no user adjustments to be made in normal use.

5 MAINTENANCE

Although no Routine Maintenance is required on the Blade, it is generally good practice to clean the inside of the equipment on each occasion that it is necessary to open it.

Dust and or light debris may accumulate in the following areas:

- Fans
- Heatsinks
- Vents

Use a fine bristle brush to remove all dust/debris from these areas, taking care not to damage the equipment.

5.1 TORQUE SETTINGS

The torque range to be used on tightening Torx screws and self-tapping screws on the Blade and SRM sub-assemblies is 8-10Lb/in (0.90-1.13 Nm).

For all other small screws (Phillips/pozi head) use a maximum of 8 Lb/in (0.90Nm).

5.2 DISASSEMBLY

When disassembling any part of the Blade take care to note where parts belong.

5.2.1 To Remove the Blade from a Rack

When also fitted with associated PSUTRAY and shelf supports:

1. Switch off at mains.
2. Undo the screws holding the front panel of the PSUTRAY.
3. Disconnect and remove the PSUTRAY.
4. Undo the four screws securing the Blade Ears to the rack.
5. If the Blade is to be removed entirely, then disconnect all cables from the rear of the equipment.
6. The Blade can now be lifted away from the shelf supports.

5.2.2 To Open the Blade



Qty 2 Fixing Screws M3

1. Remove the 2 x M3 Pan Head screws one each side of the lid.
2. Lift and pull the front edge of the lid to remove the lid.

5.2.3 To Remove a Tx or Rx Assembly

1. Disconnect the BNC connector.
2. Disconnect the DB15 power connector.
3. Disconnect the appropriate miniature 26-way and the long ribbon cables (**when refitting, take care to align centrally**).
4. Undo the two quarter-turn Dzus fasteners.
5. Lift the rear of the sub-assembly then slide backwards until the Heatsink clears the front lip of the recess (take care not to damage any of the components on the control board).

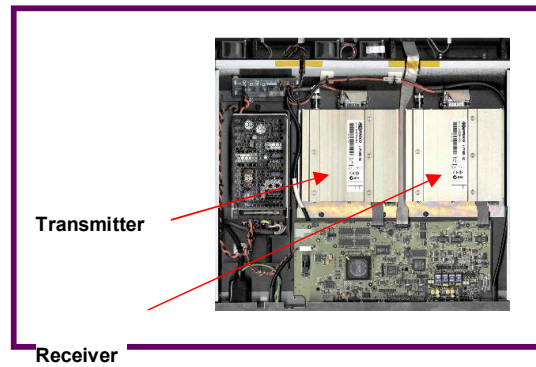

DB15 Connectors BNC Connectors

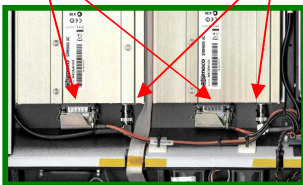

Miniature Ribbon Cables Long Ribbon Cable

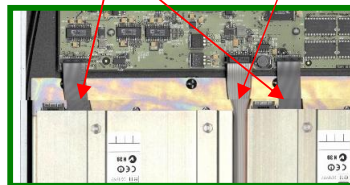

Dzus Fasteners

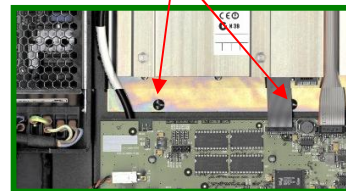

5.2.4 To Remove the Control Board

1. Remove the top cover as detailed in Section 4.2.3.
2. Disconnect the three ribbon cables from the board.

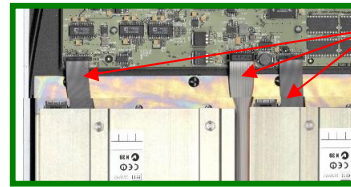

Ribbon Cables

3. Disconnect the Power Connector.



Power Connector

4. Remove the four socket fasteners from the 9-way and 37-way connectors on the rear panel.



Socket Fasteners

5. Release the three plastic locking pegs.

Press in to release

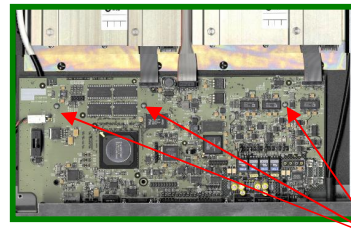
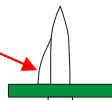

Plastic Locking Pegs

6. Carefully lift out the board taking care not to damage the Thermistor assembly underneath the board. Ensure that the Thermistor assembly is protected from damage when the Control Board is out of the Base Station chassis.

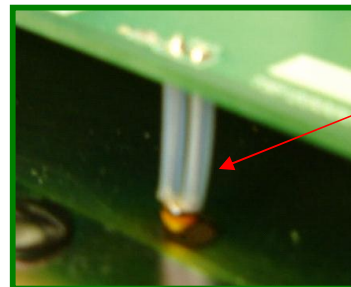

Thermistor

5.2.5 To Remove the Front Assembly

1. Remove the four, Front Panel securing screws . two per each side of the Front Panel
2. Carefully ease the front panel assembly away from the MMI assembly. Taking care to prevent damage to the control knob.

3. Carefully separate the cables (power, fans, loudspeaker, control card) taking care not to damage or unduly tension them.

5.2.6 To Remove the MMI Board

1. Remove the front assembly as described in Section 5.2.5.
2. Remove the six securing screws from the chassis brackets.
3. Detach all of the cables (power, fans, loudspeaker, control card).
4. The MMI Board may now be removed.
5. To Remove the Loudspeaker, remove the front assembly and MMI board as described above. Remove the four M3 nuts securing the Loudspeaker to the fan bulkhead.

5.2.7 To Remove a Fan

1. Remove the Front assembly as described in Section 5.2.5 and the MMI board as described in Section 5.2.6.
2. Remove the two fixing screws securing the appropriate Fan to the fan bulkhead.
3. Remove the Fan from the fan bulkhead.

5.3 RE-ASSEMBLY

In general, the re-assembly procedure is the reverse of disassembly procedure. If there are any differences or there are any special areas of concern, they are described in this section.

5.3.1 To Fit an MMI Board

1. Fit the new MMI Board to the three support brackets using six M3 mm Pan-Head Screws.
2. Offer the front panel into position ensuring the top edge of the front panel clears the control knob. Ensure that the LCD Display and the control knob are correctly centred.
3. Reverse the procedure described in Section 5.2.6.

5.3.2 To Fit the Front Assembly

1. Reverse the procedure described in Section 5.2.6 taking note of the following:

Notes: 1. Care must be taken to prevent damage to the cables and connectors when re-locating them through the access slot in the fan bulkhead and reconnecting them to the MMI board.

2. Care must be taken to prevent trapping the cables when fitting the front cover back together with the fan bulkhead.

5.3.3 To Fit the Control Board

1. Reverse the procedure described in Section 4.2.5.

Note: When positioning the Control Board, care must be taken to ensure that the Thermistor is located correctly in the hole in the base plate.

6 PRODUCT VARIANTS AND ACCESSORIES

6.1 VARIANTS

Blade - Full-Duplex Intelligent Base Station				25W Ext. PSU	25W Int. PSU	100W Version
66 - 88	MHz	E0 Band		XFINBLADE-E0	XFINBLADEI-E0	XFINPWRBLADE-E0
136 - 174	MHz	AC Band		XFINBLADE-AC	XFINBLADEI-AC	XFINPWRBLADE-AC
174 - 208	MHz	K1 Band		XFINBLADE-K1	XFINBLADEI-K1	XFINPWRBLADE-K1
208 - 245	MHz	KM Band		XFINBLADE-KM	XFINBLADEI-KM	XFINPWRBLADE-KM
310 - 350	MHz	R0 Band		XFINBLADE-R0	XFINBLADEI-R0	XFINPWRBLADE-R0
335 - 375	MHz	R1 Band		XFINBLADE-R1	XFINBLADEI-R1	XFINPWRBLADE-R1
400 - 450	MHz	TK Band		XFINBLADE-TK	XFINBLADEI-TK	XFINPWRBLADE-TK
400 - 480	MHz	TU Band		XFINBLADE-TU	XFINBLADEI-TU	XFINPWRBLADE-TU
440 - 500	MHz	UW Band		XFINBLADE-UW	XFINBLADEI-UW	XFINPWRBLADE-UW
470 - 530	MHz	WR Band		XFINBLADE-WR	XFINBLADEI-WR	XFINPWRBLADE-WR

6.2 ACCESSORIES

The full range of accessories for the Blade is shown on the two Blade Accessories Posters.

Accessories for MIC Connector	
TSF Serial Programming Lead with adaptor (DB-9)	TSF-PROGLEAD

Wall Mount Installation Items	
Wall Mount Unit with universal PSU (for single BS)	TSF-WMPS
Mains Cord for Wall Mount unit (EU/UK/US - select country)	TSF-ACCORD-EU TSF-ACCORD-UK TSF-ACCORD-US
Duplexer option for wall-mount use	TSF-DUPxx (where xx = freq band)

Rack Mount Installation Items	
Rack Mount Ears (1U)	TSF-EARS
Rack mount PSU tray (1 base station, 2U) 25 WATT	TSF-PSUTRAY
Rack mount PSU tray (1 base station, 2U) 100 WATT	TSF-2100PSUTRAY
Duplexer for PSUTRAY (specify frequencies . TSF only)	TSF-DUPxx (where xx = freq band)
Mains Cord for PSUTRAY (EU/UK/US - select country)	TSF-ACCORD-EU TSF-ACCORD-UK TSF-ACCORD-US

6.2.1 TSF-ACCORD

A 2m long cable used to connect the AC Mains Supply to the Blade, using the Wallmount, or a PSUTray in the Rackmount. Request the version relevant to the area of use:

- TSF-ACCORD-UK United Kingdom
- TSF-ACCORD-EU Rest of Europe
- TSF-ACCORD-US United States

6.2.2 Duplexers, Combiners, Cavities, RSA Units

Where a duplexer, combiner, cavity or Rx Antenna Amplifier must be re-ordered, an enquiry should be made to a qualified Project Engineer, who can advise on specific components.

6.2.3 TSF-EARS

A pair of 1U Rack Mounting Ears with screws for the Blade Base Station.

These must be used in conjunction with a rack-support

6.2.4 TSF-PROG

The **TSF** Serial Programming Lead contains an RS232 level converter. Together with the adaptor (DB-9) **it can be used to connect the Blade**, via the front panel RJ45 connector, to a PC.

6.2.5 Blade Shelves

Where a re-ordering enquiry is made with regard to Blade shelving, a qualified Project Engineer should be consulted to give advice.

Order code for a PSU tray for Blade systems involving 1-3 basestations:

PSU Trays for Blade Systems with 1-3 Basestations	
Rack mount PSU tray (19+1U for 1x 25W Blade)	TSF-1PSU1U
Rack mount PSU tray (19+1U for 2x 25W Blade)	TSF-2PSU1U
Rack mount PSU tray (19+1U for 3x 25W Blade)	TSF-3PSU1U

6.2.6 TSF-1BS PSUTRAY

A 2U-rack tray with front panel is designed for use with a Blade in an enclosed 19+rack where duplexers must be shelved alongside power supplies. The Blade plus the TSF-PSUTRAY occupies a total of 3U of rack space.

The tray is supplied complete with a universal power supply (100-240VAC, 50/60Hz, IEC input) suitable for a single Blade.

TSF-DUPLEXER may be fitted as an option.

An optional PSU may be used with the Power Blade configuration.

6.2.6.1 TSF-1BS PSUTRAY Specifications

- **Dimensions:** 480mm(W) x 400mm(D) x 90mm(H).
- **Weight:** 3.95kg.
- **Mains Connector:** IEC
- **Power requirement:** 150W
- **Fuse Rating:** 110V: T250V 4A HB
250V: T250V 2A HB.
- **Blade Cable:** Approx. 300mm

7 SPARES

7.1 SERVICE CONCEPT

The Blade series has been designed to provide a low cost trunked and non-trunked, analogue, base station, using common core electronics, software and interfacing.

It is a requirement that once the customer has purchased equipment, Team Simoco can follow this by providing ongoing, high level of customer support together with a competitive and professional servicing activity.

There are three levels of service available:

Level	Activity	Recommended Spares	Recommended Test Equipment and tools
1	<p>This is intended to achieve rapid turn around by .</p> <ul style="list-style-type: none"> • Complete replacement of transceiver or ancillaries • Replacement of sub-assemblies • Reprogramming • Checking/replacement of fuses <p>Faulty units are to be returned to a level-2 service facility with an attached fault report.</p> <p>This level of service should not exceed 20 minutes.</p>	<p>SRM sub-assembly (by band)</p> <p>Control board</p> <p>MMI board</p> <p>Fan</p> <p>Spare cable assys.</p> <p>Replacement fuses</p>	<p>Multimeter</p> <p>P.C. with Programmer</p> <p>Engineering handset</p> <p>Small flat-blade screwdriver</p> <p>Small cross-head screwdriver</p> <p>Large pozi-drive screwdriver</p>
2	<p>Level 2 service includes level 1 with the addition of fault rectification by:</p> <ul style="list-style-type: none"> • Replacement of PCB, mechanical component, or cable assembly <p>Cosmetic repair</p>	<p>Listed in Level 2 Spares Schedule</p> <p>Spare parts available to order from Central Spares</p>	<p>As above + service aids and test equipment</p>
3	<p>Repair by PCB or mechanical component replacement, Cosmetic repair.</p> <p>Repair of PCB to</p>	<p>Listed in Level 2 Spares Schedule</p> <p>Radio PCB components only</p>	<p>As above + service aids and test equipment</p>

Figure 6.1 Exploded Diagram of the Xfin Blade

7.2.2 Assembly Item List

Part Number	Part Description	Quantity
D116-0027-M-01	CASE BULKHEAD X/FIN	1
D116-0024-M-05	X-FIN FRONT PANEL (SOLID FRONT)	1
D116-0006-M-03	LID ASSY X/FIN	1
00601-0001630-0	M3X8 SCREW PAN HD POZI STL/S	2
00606-000540-0	M3 PLAIN WASHER STAINLESS/STL.	2
D116-0012-M-04	230V REAR PANEL	1
D116-0025-M-01	TSC 2000 WINDOW PROTECTION	1
D116-0028-M-02	INSULATION PAD TSF/XFIN	1
D111-0042-M-02	TSF2025I INT PSU BRKT (LAMBDA)	1
0003-0001-M-07	RACK MNTG EARS TSF2000	2
D111-0006-M-01	TSF WALL MOUNTING EAR	2
0003-0029-W-03	TSF LOUDSPEAKER ASSY	1
02800-0000175-0	FAN TYPE 412J/2H-T224-730Q	3
D111-0041-G-01	TSF2000 FUSE BOARD	1
02700-0000140-0	KNOB CONTROL SILVER 25MM	1
01109-0000120-0	LIGHT GUIDE 14mm ROUNDED	5
00304-0002190-0	CONNECTOR IEC FLANGED	1
00304-0002110-0	CONNECTOR CLIP RETAINING	1
D116-0013-W-02	RF CABLE RX TSC2000	1
D116-0022-W-01	X/FIN DC POWER LOOM INTERNAL	1
D116-0015-W-02	TSC2000 PA TO CTRL PCB CBL FRM	1
0003-0018-W-01	RIBBON CABLE RX/TX SRM	2
D116-0014-G-03	MMI ASSY - X/FIN	1
D116-0001-G-03	CONTROL BOARD ASSY - X/FIN	1
59800-0000034-0	FUSEHOLDER PCB 20X5MM	1
00806-0000130-0	FUSE COVER CLEAR	1
00804-0000002-0	FUSE 10A Q/BLOW GLASS 20MM	2
00804-0000180-0	2A 20MM QB GLASS	1
52701-0000040-0	PSU 12V 150W (TSF2025i)	1
00602-0000360-0	RECEPTACLE DZUS 334-200-190	4
00603-0000210-0	PCB SUPPORT - BLIND HOLE 4.8mm	4
3513 903 67181	LABEL T/A & UNIT SRM9000	3
00601-0001660-0	M3X8 PAN HD POZI-BLACK	4
00601-0000420-0	M3 X8 POZI P/HD BZP	6

00601-0000585-0	M3 X 30 POZI P/HEAD	6
00601-0000700-0	M4 X10 CSNK POZI	4
00601-0000760-0	M5 X20 POZI P/HD BZP	1
00602-0000120-0	M3 NUT BZP	8
00601-0001560-0	NUT M5 HEX STEEL ZINC PLATE	3
00606-0000220-0	M4 PLAIN WASHER BZP	2
00601-0001570-0	S/P WASHER STEEL ZINC/P M4	2
00601-0000440-0	M3 X10 POZI P/HD BZP	2
00606-0000180-0	M3 PLAIN WASHER BZP	2
00601-0000650-0	M4 X 6 P/HD POZI	2
D111-0046-W-03	IEC CONN TO LAMBDA PSU CBL	1
00606-0000190-0	M3 S/P WASHER BZP	4
0003-0016-W-01	TSF2000 RX TX CABLEFORM	1
00601-0001570-0	S/P WASHER STEEL ZINC/P M4	2
00601-0001580-0	WASHER PLAIN M5 ZINC PLATE	2
D116-0031-W-01	XFIN MMI TO FUSE PCB CBL FORM	1
01202-0000150-0	XFIN PACKING BOX	1
01202-0000160-0	XFIN PACKING BAG	1
01202-0000170-0	XFIN ETHER FOAM PACKING	1
PA-ACCORD-UK	CORD AC POWER UK	1
D116-0030-W-01	XFIN CTRL PCB TO PSU CBL FRM	1
02313-0000010-0	ENCODER 15mm KNURLED SHAFT	1
01108-0000010-0	DISPLAY LCD WHITE/BLUE	1

7.3 WARRANTY

Unless superseded by specific contractual/supply agreements, the normal statutory 24 - month warranty will apply to all base stations and ancillaries.

7.3.1 Service Within and Out Of Warranty

Please contact our Central Repair facility regarding support of either type.

customerservices@teamsimoco.com

Tel: +44 (0)1332 375620

In some countries a local Simoco agent may be responsible for providing this service.

7.3.2 Ancillary Items

Please contact our Central Repair facility regarding service, for replacement of these parts.

customerservices@teamsimoco.com

Tel: +44 (0)1332 375620

7.3.3 Unpacking Equipment

Any damaged or missing parts must be notified to Team Simoco or their agent in writing within 10 days of receipt.

7.4 SOFTWARE POLICY

Software provided by Team Simoco shall remain the Company's property, or that of its licensors and the customer recognises the confidential nature of the rights owned by the Company.

The customer is granted a personal, non-exclusive, non-transferable limited right of use of such software in machine-readable form in direct connection with the equipment for which it was supplied only.

In certain circumstances the customer may be required to enter into a separate licence agreement and pay a licence fee, which will be negotiated at the time of the contract.

The customer undertakes not to disclose any part of the software to third parties without the Company's written consent, nor to copy or modify any software. The Company may, at its discretion, carry out minor modifications to software. Major modifications may be undertaken under a separate agreement, and will be charged separately.

All software is covered by a warranty of 3 months from delivery, and within this warranty period the Company will correct errors or defects, or at its option, arrange free-of-charge replacement against return of defective material.

Other than in the clause above, the Company makes no representations or warranties, expressed or implied such, by way of example, but not of limitation regarding merchantable quality or fitness for any particular purpose, or that the software is error free, the Company does not accept liability with respect to any claims for loss of profits or of contracts, or of any other loss of any kind whatsoever on account of use of software and copies thereof.

8 LCD MENU OPERATION

8.1 DEFAULT DISPLAY

The LCD Display is a back-lit alphanumeric 2-line visual output which shows status, menu options and call activity.

Immediately following power-up, the LCD indicates its progress through the boot-up procedure. A typical sequence is:

<i>BLADE Xfin Loading...</i>
<i>Init</i>
<i>Available</i>

Additional status changes include adoption of Control status, the *q* marker indicating assumption of site master status and the *#* marker which indicates assumption of system master status (in a multi-site configuration).

8.2 MENU STRUCTURE

The Xfin Blade menu is manipulated via the control knob. Rotating the knob while in default state will alter the loudspeaker volume setting.

Pressing the knob once from the default display opens the main menu, with the current option displayed on the screen. Rotating the control knob cycles through the available options, which are:

1. Alarms
2. Set IP Address
3. Set Position in Site
4. Set Site ID
5. Set System ID
6. Enable Screen Saver
7. Test Menu
8. Exit

Where a menu selection gives the option of altering parameters (e.g. entering a series of digits), this may be carried out by:

- moving the underline cursor to the variable in question by rotating the knob
- pressing the button to select the digit
- rotating the knob to alter the value
- pressing the knob to set the digit

- moving the cursor to the tick mark at the side of the screen when all variables are altered and pressing to confirm (an \times on the other side of the screen can be selected to cancel the alteration).

Where a variable can only be increased or decreased, no cursor, tick or \times symbols are present.

8.2.1 Alarms Menu

If the Alarm LED is lit (red LED on the far right hand side of the Blade front-panel), the Alarms menu will display the details of each alarm . for example Fan Too Slow, No DSP, No Rx Module+etc. Each alarm message is displayed by rotating the control knob.

8.2.2 Set IP Address

Accessing this menu displays the current IP address as four 3-digit sections. This address may be altered from this section.

8.2.3 Set Position in Site

Accessing this menu displays the current position in site as a 2-digit decimal number. This number may be altered from this section.

8.2.4 Set Site ID

Accessing this menu displays the current site ID as a 2-digit decimal number. This number may be altered from this section.

8.2.5 Set System ID

Accessing this menu displays the current system ID as a 2-digit decimal number. This number may be altered from this section.

8.2.6 Enable Screen Saver

This section allows the user to enable the screen saver. The screen saver activates after the LCD menu has not been accessed for a set period.

8.2.7 Test Menu

This menu is for engineering use only and should only be access by qualified personnel. It can be used to assist with the configuration of audio levels and the testing of communication paths.

8.2.8 Exit

Select this option to exit the menu and revert to the display of current status..

9 PROGRAMMER GUIDE

9.1 GETTING STARTED

Ensure that the PC is connected to the Xfin Blade Management Terminal via a CAT 5 Ethernet cable or a RS232 Serial cable. This provides the communications link between the Xfin Blade Management Terminal and the Xfin Blade.

9.1.1 Main Screen

The main menu by default displays clickable buttons of several configurable areas. Some areas will be hidden depending on whether the Xfin Blade Management Terminal is in Single Site or Multi Site. The areas are:

- Switch
- Site Configuration
- Xfin Blades
- Channels
- Channel Lists
- PABX/PSTN
- Operating Parameters
- Fleets
- Subscribers
- Access Levels
- Diversions
- White List
- Timers
- Time Schedule
- External Alarms
- Queue Depths
- VOX

9.2 DATABASE

The Xfin Blade Management Terminal requires a database to be created to store raw data. This data can then be used to configure an Xfin Blade. When configuring the Xfin Blade data is taken from the database and sent to the Xfin Blade. Data that the Xfin Blade Management Terminal receives from the Xfin Blade is also stored within the database.

9.2.1 Creating a New Database

Located across the top of the Main Menu form there is a menu bar. To create the new database click on Database tab, then select New from the drop down. A window will appear allowing a new database to be created in a location of choice. Use the save in drop down box to navigate to the area where the database is to be stored. Give the database a name using the File Name box and then click on save. Clicking on cancel instead would bring back the main menu form.

9.2.2 Opening a Database

Multiple databases can be created however the Xfin Blade Management Terminal will only use one database at a time. Xfin Blade Management Terminal offers the ability to switch between the databases by selecting Database from the menu bar at the top of the form, and clicking Open in the drop down. Using the Look in drop down box navigate the database to be opened. Select the database by clicking on the database to highlight it. Now select the button Open which will load in that database. Clicking cancel instead will bring back the main menu.

9.3 COMMUNICATIONS SETTINGS

To connect to the Xfin Blade the communications settings will first need to be altered. This is located in the menu bar running across the top of the form, under Communications. On this form there are options for Ethernet and Serial.

9.3.1 Connection Type

There are two options Ethernet via CAT 5 cable, or Serial via RS232. Select the type of connection by left clicking on one of the radio buttons in the Ethernet Communications box.

9.3.2 Serial Communications

The Serial Communications needs to be configured when Serial is selected in the Connection Type box. There are five setting in the Serial Communications:

- **Com Port** . This is the serial communication port being used to connect to the Xfin Blade. To select a Com Port click on the arrow in the box to the right of Com Port and select a Com Port from the drop down list.
- **Baud Rate** . This is the speed at which the data is passed through the serial connection. To Select a Baud Rate click on the arrow in the box to the right of Baud Rate and select a Baud Rate from the drop down list.
- **Parity** . This is a type of error detection using bit checking. To select a Parity click on the arrow in the box to the right of Parity and select a Parity from the drop down list.
- **Stop Bits** . This is the bit that signals the end of a transmission on the serial line. To select a Stop Bit click on the arrow in the box to the right of Stop Bit and select a Stop Bit from the drop down list.

- **Flow Control** . This is used to regulate the rate at which information is transferred from one device to another. To select a Flow Rate click on the arrow in the box to the right of Flow Rate and select a Flow Rate from the drop down list.

Now that the Serial Communications setting have been configured click on Save & Exit to menu to the main menu. Alternatively click on refresh to set the setting back to what they were when the Communications Settings form was first opened.

9.3.3 Ethernet Communications

The Ethernet Communications options needs to be configured when Ethernet is selected in the Connection Type box. There are four settings in the Ethernet Communications:

- **Connect to Site Master/Connect to System Master** . This option allows you to choose whether to connect to the Site master or if you want to connect to the System master.
- **Site ID** . This is the ID of the site that you want to connect to. The Site ID is set from a Xfin Blades front panel.
- **System ID** . This is the ID of the system that you want to connect to. The System ID is set from a Xfin Blades front panel.
- **UDP Listening Port** . This is the port that the Xfin Blade Management Terminal listens for a connection on. To set this port, click on the box to the right of UDP Listening Port and enter a port number. The default value for this port is 4950.

Now that the Ethernet Communications setting have been configured click on Save & Exit to menu to the main menu. Alternatively click on refresh to set the setting back to what they were when the Communications Settings form was first opened.

9.3.4 Open Comms

To be able to send messages to the Xfin Blade, communications firstly has to be established between the Xfin Blade Management Terminal and Xfin Blade. Ensure that the Communication settings are correct.

From the main menu window select Communications from the menu bar that is located across the top of the form. Left click on Open Comms from the drop down list. The Xfin Blade Management Terminal will now attempt to connect to the Xfin Blade. If the Xfin Blade Management Terminal was successful then Established will be displayed in the button left hand corner of the main menu.

If the Xfin Blade Management Terminal does not go in to Established then make sure that the Communication Settings are correct and then retry connecting.

9.4 STATE

There are two states that the Xfin Blade Management Terminal can be in. The state will determine how the Xfin Blade Management Terminal configures the Xfin Blade.

- **Offline** . When in offline mode any changes that are made to the data contained in the Xfin Blade Management Terminal will not be sent to the Xfin Blade. To place

the Xfin Blade Management Terminal in to offline mode click on the small box in the status bar of the main menu until it says offline.

- **Live** . When in live mode any changes that are made to the data contained in the Xfin Blade Management Terminal will also be sent to the Xfin Blade. To place the Xfin Blade Management Terminal in to Live mode make sure that the Live mode click on the small box in the status bar of the main menu until it says live.

9.5 AREA CONFIGURATION

Choose an area from the main menu to configure by left clicking on one of the large buttons, which are located in the middle on the main menu form.

The area form will now be shown with the configurable fields. The majority of the forms all follow this same format and allow you to edit, add, delete, get, get configuration, accept/send, send configuration and reset configuration. The mode effects differ if the Xfin Blade Management Terminal is in Live or Offline state. When the Xfin Blade Management Terminal is in Live mode the changes happen to the Xfin Blade Management Terminal and the Xfin Blade. When the Xfin Blade Management Terminal is in Offline mode the changes are only stored in the Xfin Blade Management Terminal.

9.5.1 Edit

To alter any of the fields shown on the form the form needs to be in edit mode. Once the form is set to edit mode the boxes that were blanked out are now available for altering. Edit mode will allow you to only alter an existing record.

To set the form in to edit mode left click on the Edit button located on the right hand side of the screen. To get out of edit mode, click on accept or cancel. Accept will store the changes, if any that have been made. Cancel will ignore any changes that have been made and return back to its previous state.

9.5.2 Add

Add mode allows a new record to be added to the Xfin Blade Management Terminal. Left click on the add button which is locate to the right of the form and an empty form will be shown. Enter the required data in to all of the boxes.

To accept the record click on the accept button. To cancel the record, click on the cancel button.

9.5.3 Delete

Delete will remove the current selected record that is being shown from the Xfin Blade Management Terminal and the Xfin Blade depending on the state of the programmer. Left click on the delete button located on the right hand side of the form to delete the record.

9.5.4 Accept/Send

Accept/Send will accept the record that is currently being show on the form. Accept/Send will also send the record to the Xfin Blade as long as comms are established. Left click on the Accept/Send button located on the right hand side of the form to Accept/Send a record.

9.5.5 Get Record

As long as the Xfin Blade Management Terminal has established a connection to an Xfin Blade Get Record will retrieve an update on the current selected record. To do a Get Record left click on the Get Record button located on the right hand side of the form.

9.5.6 Send Configuration

As long as the Xfin Blade Management Terminal has established a connection to an Xfin Blade Send Configuration will send every record for the current area to an Xfin Blade. To Send Configuration left click on the Send Configuration button located on the right hand side of the form.

9.5.7 Get Configuration

As long as the Xfin Blade Management Terminal has established a connection to an Xfin Blade Get Configuration will retrieve every record that is store in the Xfin Blade for that area. To Get Configuration left click on the Get Configuration button located on the right hand side of the form.

9.5.8 Reset Configuration

Reset Configuration offers the user the choice to delete everything that is in the Xfin Blade Management Terminal's current database for that area or to delete everything in the database for that area for the Xfin Blade and the Xfin Blade Management Terminal.

9.5.9 Navigation Buttons

One area can store multiple records and the form can only show one record at a time. The navigation buttons located below the forms data boxes.

- The double arrow that points to the left displays the first record.
- The double arrow that points to the right displays the last record.
- The single arrow that points to the left displays the previous record.
- The single arrow that points to the right displays the next record.



Team Simoco Ltd, Field House, Uttoxeter Old Road, Derby DE1 1NH

Tel: +44 (0) 1332 375500
FAX: +44 (0) 1332375501

www.teamsimoco.com

A. GLOSSARY AND ABBREVIATIONS

TX	Transmit
RX	Receive
DSP	Digital Signal Processor
USB	Universal Serial Bus
MII	Media-Independent Interface
JTAG	Joint Test Action Group
EMI	Electro-Magnetic Interference
GPIO	General Purpose Input/Output
PCB	Printed Circuit Board
PHY	PHYSical layer interface
SDRAM	Synchronous Dynamic Random Access Memory
UART	Universal Asynchronous Receiver-Transmitter
MMI	Man-Machine Interface
RTC	Real Time Clock
PA	Power Amplifier
CoDec	Coder/Decoder
TSC	Trunked Site Controller
RTS	Request To Send (RS232 flow control signal)
CTS	Clear To Send (RS232 flow control signal)
PSTN	Public Switched Telephone Network
TBR	Technical Basis for Regulation
LVD	Low Voltage Directorate
NIC	Network Interface Controller
LCD	Liquid Crystal Display
SPORT	Serial PORT of the digital signal processor
ROM	Read Only Memory
NC	Not Connected
E&M	Ear and Mouth
DAA	Data Access Arrangement

B. CONTROL CARD BLOCK DIAGRAM

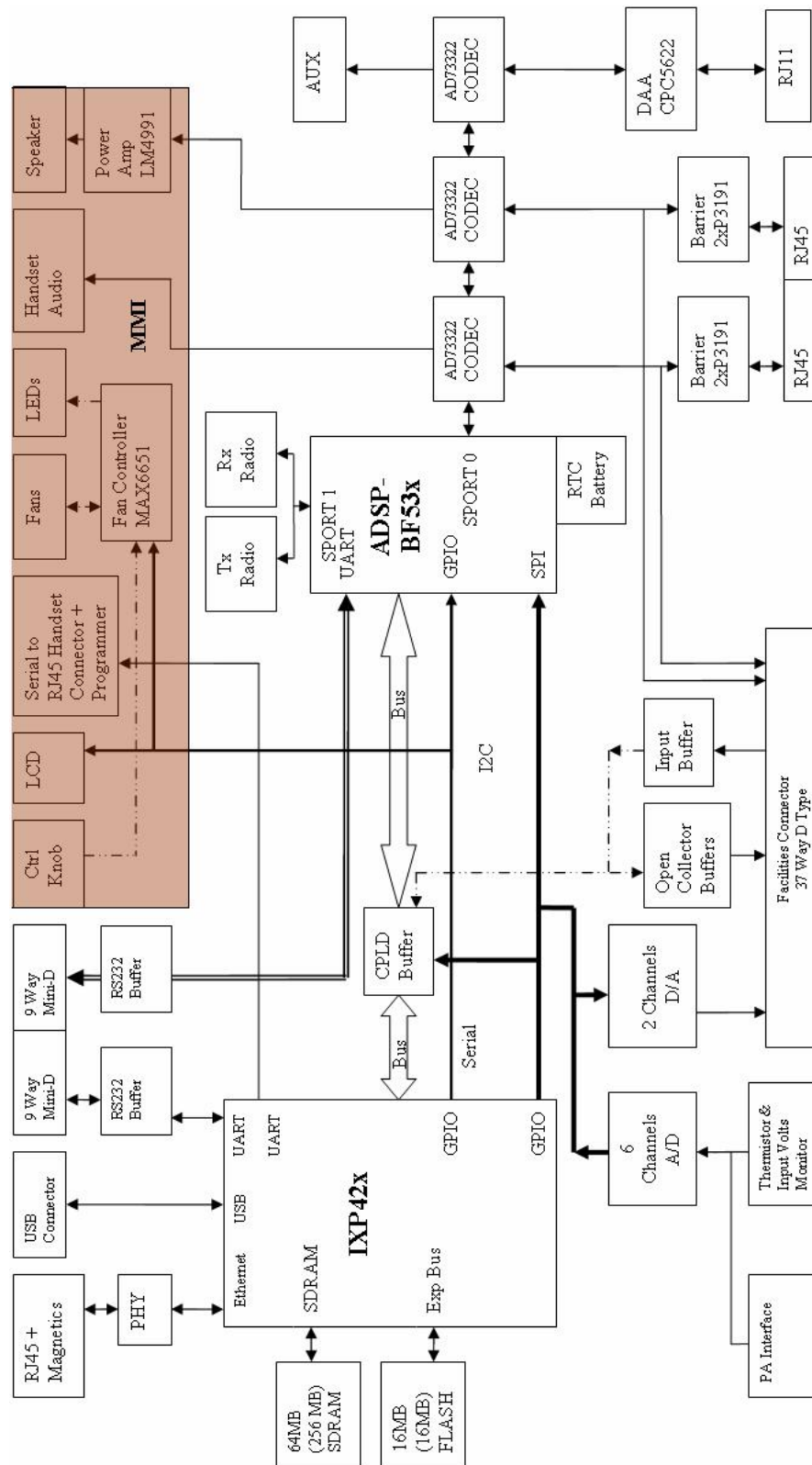

C. RADIO FREQUENCY HAZARD INFORMATION

RF Hazard Test conducted by EMC Technologies (NZ) Ltd - test report no. 70232.1.
Report date: 26 March 2007.

Test report is as follows:

As per Section 1.1310 and Section 2.1091 certification of this transmitter is sought using the Controlled / Occupational exposure limits as detailed in OST/OET Bulletin Number 65 as a power of 100 watts is to be used in a fixed environment.

Calculations have been made using the General Public/Uncontrolled Exposure limits.

Minimum safe distances have been calculated below.

Power density, $W/m^2 = E^2/3770$

- Occupational / Controlled Exposure limit will be 1.46 mW/cm^2
($f/300 = 440 \text{ MHz}/300$)

- General Population / Uncontrolled exposure limit will be 0.29 mW/cm^2
($f/1500 = 440 \text{ MHz}/1500$)

The minimum distance from the antenna at which the MPE is met is calculated from the equation relating field strength in V/m, transmit power in watts, transmit antenna gain, transmitter duty cycle and separation distance in metres:

$$E, \text{ V/m} = (\frac{1}{2}(30 * P * G)) / d$$

Controlled Uncontrolled

$$E = 1.46 \text{ mW/cm}^2 = E^2/3770$$

$$E = \sqrt{1.46 * 3770}$$

$$E = 74.2 \text{ V/m}$$

$$E = 0.29 \text{ mW/cm}^2 = E^2/3770$$

$$E = \sqrt{0.29 * 3770}$$

$$E = 33.1 \text{ V/m}$$

The rated maximum transmitter power = 100.0 watts.

Transmitter operated using a quarter wave whip antenna with a gain of 2.15 dBi (1.64).

Controlled Uncontrolled

$$d = \frac{1}{2}(30 * P * G * DC) / E$$

$$d = \frac{1}{2}(30 * 100.0 * 1.64) / 74.2$$

$$d = 0.94 \text{ metres or } 94 \text{ cm}$$

$$d = \frac{1}{2}(30 * 25.0 * 1.64) / 33.1$$

$$d = 2.11 \text{ metres or } 211 \text{ cm}$$

Result: Complies