

Simplicity[™] Serge PRO[™]

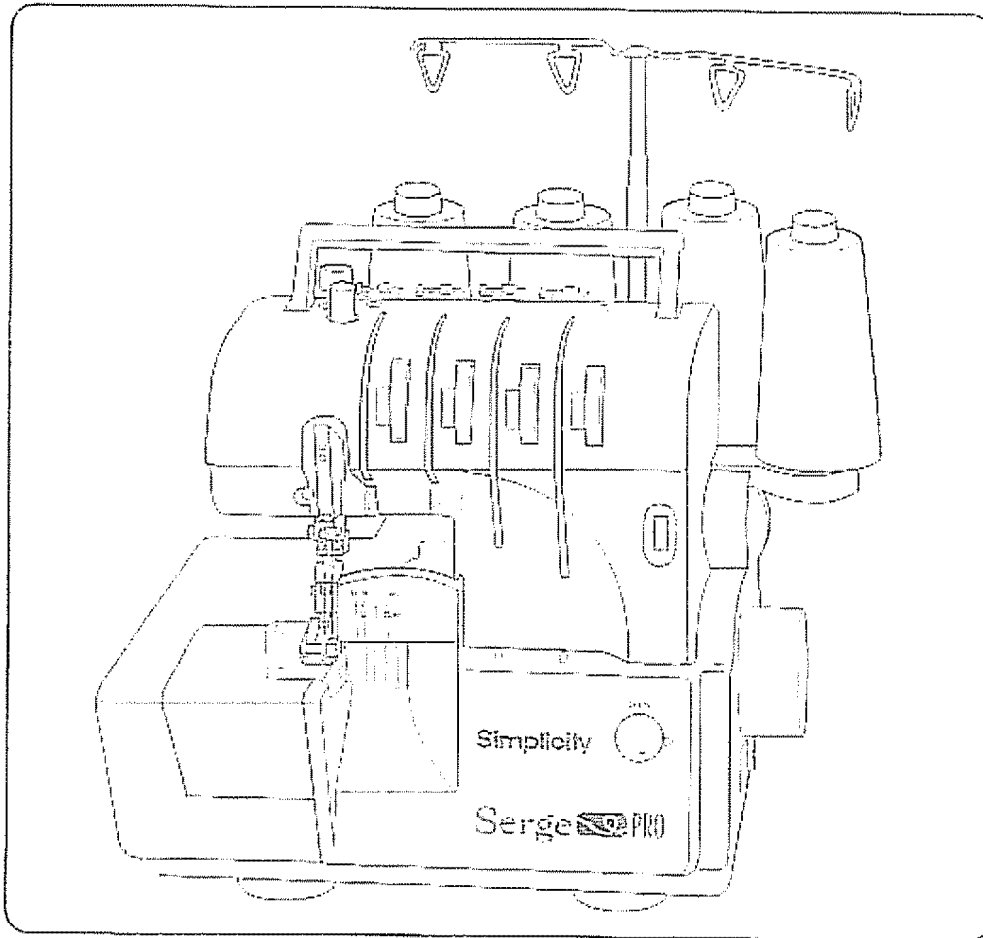

Serger Model SW432

INSTRUCTION MANUAL

Manual de Instrucciones

Simplicity Sewing Machine Education Helpline: 800-822-6691

IRSW432

INSTRUCTION AND REFERENCE GUIDE

This sewing machine is intended for household use.

IMPORTANT SAFETY INSTRUCTIONS

When using a sewing machine, basic safety precautions should always be followed, including the following. Read all instructions before using.

DANGER - To reduce the risk of electric shock:

1. Never leave unattended when plugged in. Always unplug this machine from the electric outlet immediately after using and before cleaning.
2. Always unplug before relamping. Replace bulb with same type rated 10 Watts.

WARNING - To reduce the risk of burns, fire, electric shock, or injury to persons:

1. Do not allow to be used as a toy. Close attention is necessary when this sewing machine is used by or near children.
2. Use this sewing machine only for its intended use as described in this manual. Use only attachments recommended by the manufacturer as contained in this manual.
3. Never operate this sewing machine if it has a damaged cord or plug, if it is not working properly, if it has been dropped or damaged, or dropped into water. Return the sewing machine to the nearest authorized dealer or service center for examination, repair, electrical or mechanical adjustment.
4. Never operate the sewing machine with any air openings blocked. Keep ventilation openings of the sewing machine and foot controller free from the accumulation of lint, dust, and loose cloth.
5. Never drop or insert any object into any opening.
6. Do not use outdoors.
7. Do not operate where aerosol (spray) products are being used or where oxygen is being administered.
8. To disconnect, turn the power switch to the off position, then remove plug from outlet.
9. Do not unplug by pulling on cord. To unplug, grasp the plug, not the cord.
10. Keep fingers away from all moving parts. Special care is required around the sewing machine needle and knives.
11. Always use the proper needle plate. The wrong plate can cause the needle to break.
12. Do not use bent needles.
13. Do not pull or push fabric while stitching. It may deflect the needle causing it to break.
14. Switch the sewing machine off when making any adjustments in the needle area, such as threading needle or loopers, changing needle, blade, or needle plate.
15. Always unplug the sewing machine from the electrical outlet when removing covers, lubricating, or when making any other user servicing adjustments mentioned in this manual.

SAVE THESE INSTRUCTIONS

TABLE OF CONTENTS

SPECIFICATIONS	1	ROLLED OVEREDGE-Method B	15
GETTING TO KNOW YOUR SERGER	2	thread tension-Method B	15
ACCESS TO THREAD GUIDES AND FREE ARM	3	TWO THREAD SERGING	16
ELECTRICAL CONNECTION	4	to convert from 3-thread to 2-thread sewing	16
ACCESSORIES	4	thread tension	17
INSERTING THE NEEDLE	5	to convert from 2 thread to 3- or 4- thread sewing	17
NEEDLE, THREAD AND FABRIC CHART	5	FREE ARM SEWING	17
THREADING THE MACHINE	6	BLIND HEMMING	18
extension bar	6	changing the presser foot	18
threading the upper looper	7	setting controls	18
threading the lower looper	8	sewing	18
threading the right and left needles	9	SEWING WITH THE UPPER BLADE DISENGAGED	19
easy thread changing - Tying On method	9	sewing	19
BEFORE STARTING TO SEW	10	FLATLOCK SEAM	20
starting to sew	10	setting controls	20
presser foot markings	10	thread tension	20
end of seam	10	sewing	20
when thread breaks	10	PIN TUCKING	21
OVERLOCK SEWING (2-needle, 4-thread)	11	sewing	21
FOUR THREAD TENSION	11	ELASTIC FOOT	21
SETTING STITCH LENGTH	12	DECORATIVE OVERLOCK	22
ADJUSTING THE DIFFERENTIAL FEED	13	TURNING CORNERS	22
SETTING THE SEAM WIDTH	12	outside corner	22
ADJUSTING THE PRESSURE ON FABRIC	13	inside corners	22
OVERLOCK SEWING (1-needle, 3-thread)	13	outside curves	22
three thread tension	13	CLEANING AND MAINTENANCE	23
NARROW AND ROLLED HEMMING	14	cleaning	23
changing the needle plate	14	oiling	23
setting controls	14	changing the sewing light	23
sewing	15	changing the lower blade	23
thread tension-Method A	15	BEFORE YOU CALL FOR SERVICE	24
		STITCH SELECTION CHART	25

SPECIFICATIONS

Stitch length	1.4 mm
Differential feed ratio	0.7-2.0
Seam width	Left needle: 6.2-7.2 mm; Right needle: 4.0-5.0 mm
Needle bar stroke	27 mm
Presser foot	Hinged, Snap on type
Presser foot lift	5 mm
Needle	Type Schmetz ELx705 or Organ HAx ¹ size 75-90/11-14
Number of threads	4, 3, 2
Dimensions	Width: 290 mm x Depth: 230 mm x Height: 320 mm
Net weight	6.7 kg

GETTING TO KNOW YOUR SERGER

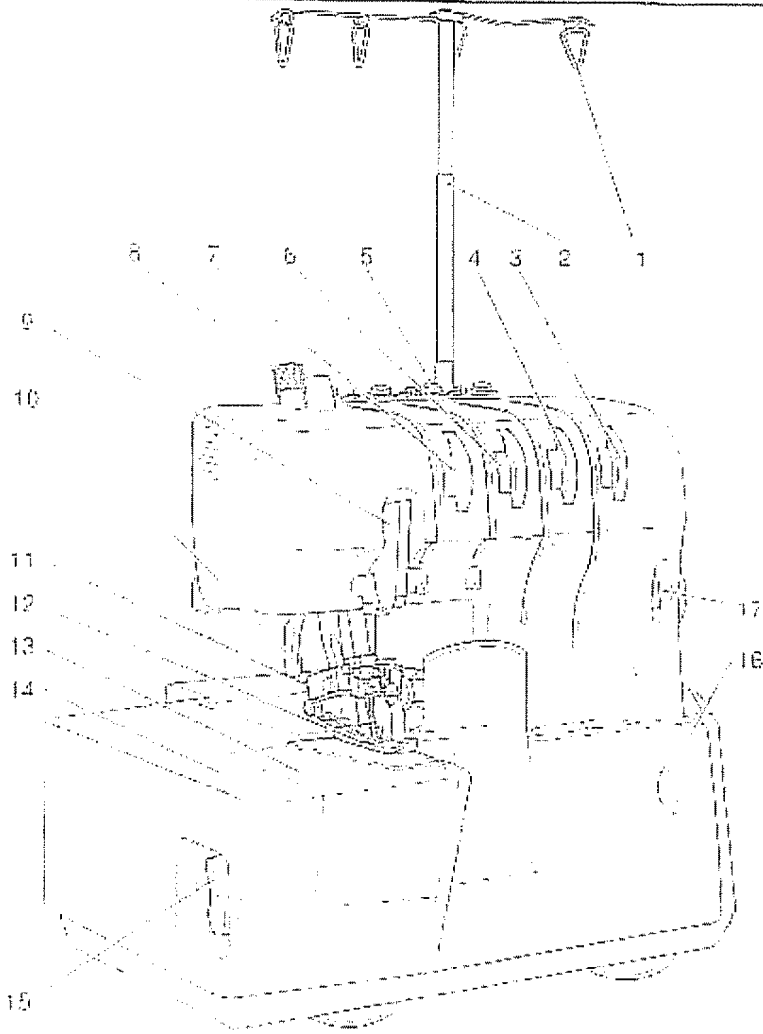

- 1. Thread Guide Hanger
- 2. Extension Bar
- 3. Lower Loper Thread Tension Dial (Blue)
- 4. Upper Loper Thread Tension Dial (Green)
- 5. Thread Guide and Tension Disc
- 6. Right Needle Thread Tension Dial (Yellow)
- 7. Left Needle Thread Tension Dial (Red)
- 8. Pressure Regulator
- 9. Thread Take-up Lever
- 10. Presser Foot Lifter
- 11. Presser Foot Releasing Lever
- 12. Presser Foot
- 13. Free Arm
- 14. Extension Table
- 15. Extension Table Lock/Release Lever
- 16. Front Cover
- 17. Stitch Length Window

FRONT VIEW

- 18. Differential Feed Indicator
- 19. Stitch Length Regulator Dial (outside dial)
- 20. Differential Feed Regulator Dial (inside dial)
- 21. Hand Wheel
- 22. Light & Power Switch
- 23. Terminal Box
- 24. Spool Stand
- 25. Spool Pin
- 26. Spool Supporter
- 27. Handle

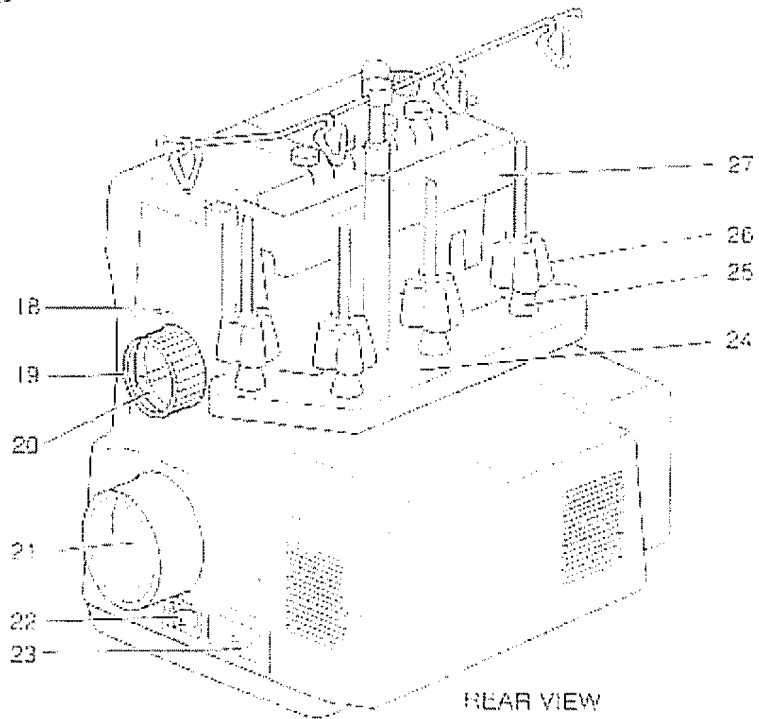

REAR VIEW

INSIDE OF FRONT COVER AND FREE ARM COVER

1. Needle Clamp
2. Upper Blade Holder
3. Upper Blade
4. Needle Plate
5. Seam Width Knob
6. Upper Looper
7. Lower Looper
8. Lower Blade

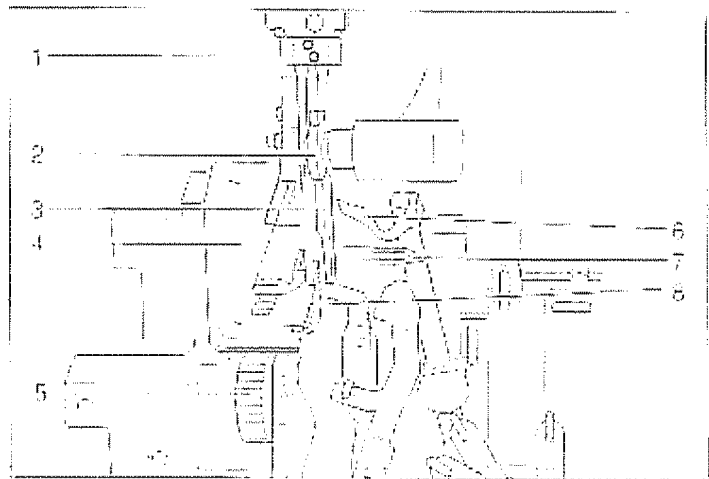

ACCESS TO THREAD GUIDES AND FREE ARM

1. Place thumb in hollow of front cover and slide it to the right as far as possible; pull cover down towards you
2. To close, lift cover up and it will snap into place.
3. Be sure that the cover is properly closed before starting to sew.



Opening the Extension Table

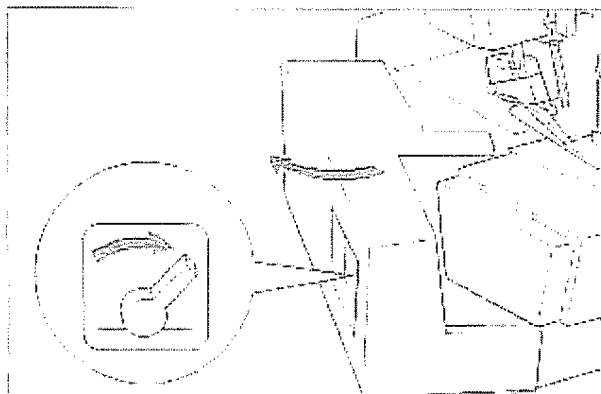

1. Turn lever located on left side of Extension Table towards front of machine
2. Pull Extension Table out to open.
3. To close push shut and turn lever in opposite direction. This locks the Extension Table to Free Arm Cover.

Removing the Free Arm Cover

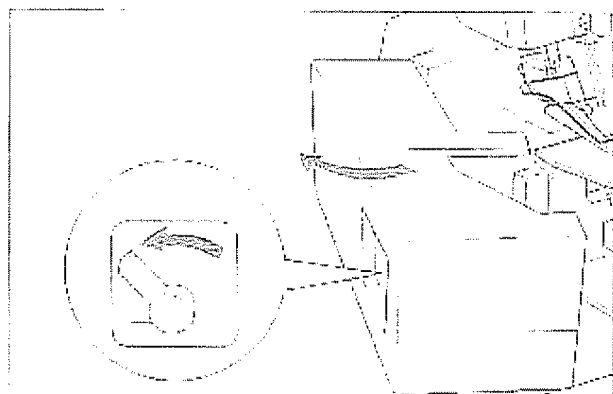

Swing Extension Table out with lever in locked position and Free Arm Cover will stay attached to the Extension Table.

ELECTRICAL CONNECTION

Connect the electrical cord to the machine by inserting the three-hole plug into the terminal box located on the right side of the machine.

Connect the cord plug into an electrical outlet.

POLARIZED PLUG INFORMATION

This appliance has a polarized plug (one prong wider than the other). To reduce the risk of electric shock, this plug is intended to fit in a polarized outlet only one way. If the plug does not fit fully in the outlet, reverse the plug. If it still does not fit, contact a qualified electrician to install the proper outlet. Do not modify the plug in any way.

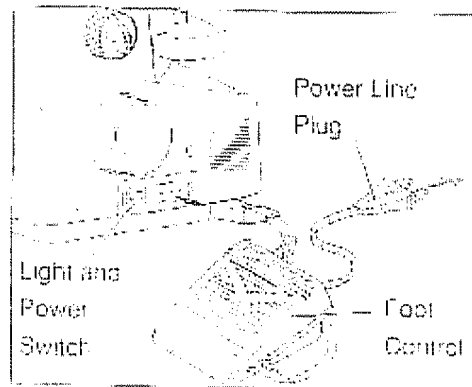

LIGHT AND POWER SWITCH

The light and power switch is located alongside the terminal box. To turn power on, push on left side of switch. Turning on the power lights up the stitching area. The machine will not operate unless the switch is on.

FOOT CONTROL (Model 4C-316B)

This foot control was designed exclusively for this machine, and is not to be used on any other machine; nor should any other foot control be connected to this machine.

Place Foot control on floor where it is easy to reach with your foot.

To make machine go faster, press down on foot control; to slow down let up slightly.

CAUTION:

Disconnect the electrical cord from the wall outlet when machine is not in use or when it is being cleaned.

Turn the power switch to the "OFF" position before changing needles or needle plates, and before connecting the cord. This will help prevent accidents.

ACCESSORIES

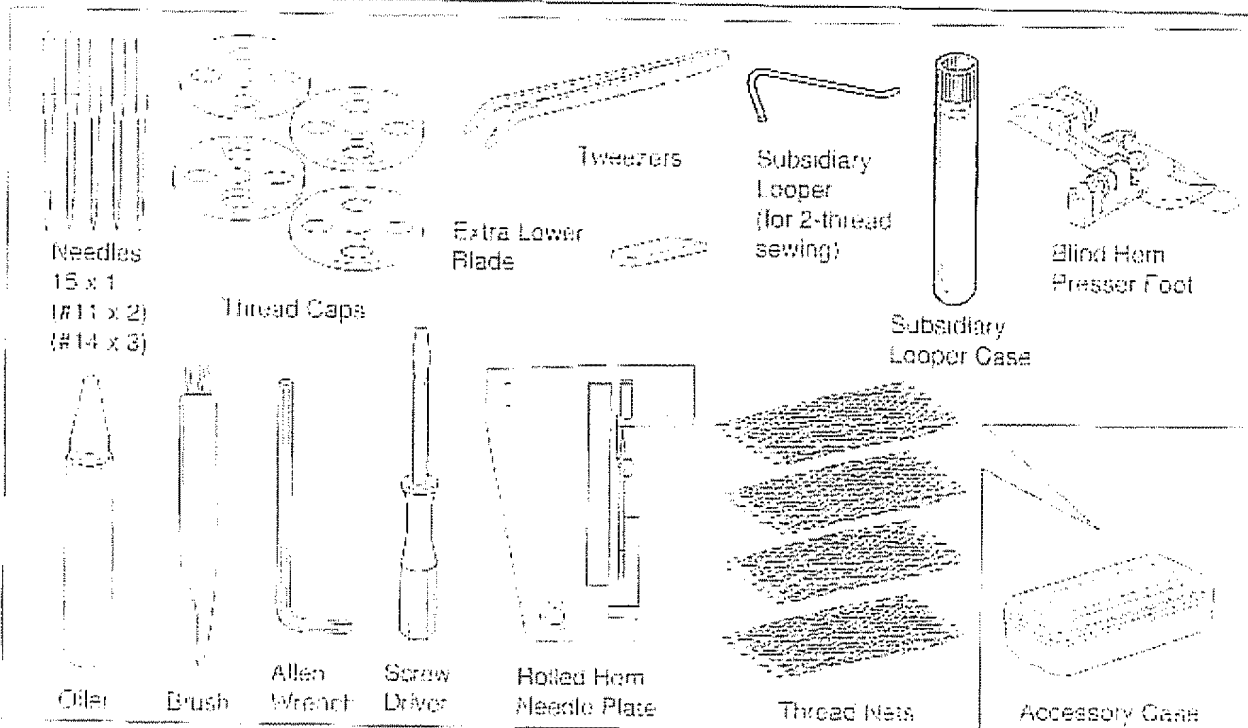

INSERTING THE NEEDLE

Select the proper type and size needle for fabric used. (See below "NEEDLE, THREAD AND FABRIC CHART")

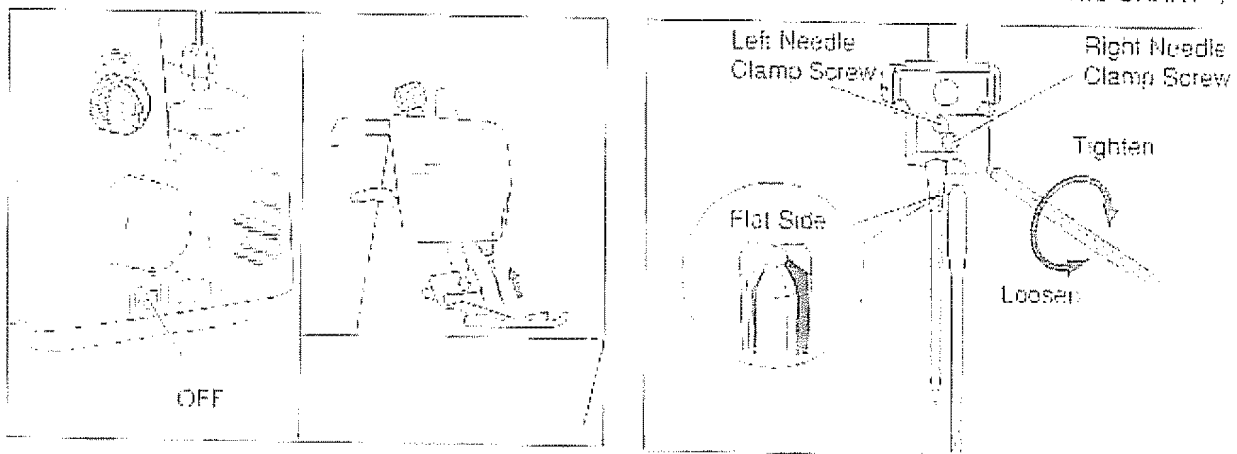

1. Turn electrical power off
2. Turn hand wheel towards you until the needle comes to its highest point
3. Use the allen wrench to loosen the Left and/or Right needle clamp screw, and remove the needle.
4. Place flat side of needle toward back of the machine and insert in needle clamp as far as it will go.
5. Retighten the screw

NEEDLE, THREAD AND FABRIC CHART

The chart shows size and type of thread and needle size for various weights and types of fabrics. Size means the fineness of both needle and thread.

FABRICS		THREADS	NEEDLE SIZES
LIGHTWEIGHT: organdy, voile, taffeta, lawn, crepe.		Cotton #100 Silk #100 Spun #80-100 Tetron #90	Schmetz ELx705: 80/12 or Organ HAx1: 75/11
MEDIUM WEIGHT: gingham, satin, seersucker, linen, velveteen, gabardine, broadcloth		Cotton #60-80 Silk #50 Spun #60-90 Tetron #60-80	Schmetz ELx705: 80/12, 90/14 or Organ HAx1: 75/11, 90/14
HEAVY WEIGHT: denim, tweed, corduroy, pile fabrics.		Cotton #40-60 Silk #40-50 Spun #60-90 Tetron #50-60	Schmetz ELx705: 90/14 or Organ HAx1: 90/14
	tricot	Spun #60-80 Tetron #60-80 Woolly Nylon	Schmetz ELx705: 90/14 or Organ HAx1: 75/11
KNIT	jersey	Spun #60-80 Tetron #60 Woolly Nylon	Schmetz ELx705: 80/12 or 90/14 Organ HAx1: 75/11, 90/14
	wool	Spun #60-80 Tetron #50-60 Woolly Nylon Woolly Tetron	Schmetz ELx705: 90/14 or Organ HAx1: 90/14

THREADING THE MACHINE

When threading, be sure to follow the directions given below. The machine must be threaded in the proper sequence in order to sew. An illustration for correct threading is inside the front cover of the machine.

The thread guides are identified with color markings corresponding to the thread to which they belong. Always thread the upper and lower loopers before threading the needles.

Thread Sequence

1. Upper Looper (Green)
2. Lower Looper (Blue)
3. Right Needle (Yellow)
4. Left Needle (Red)

extension bar

1. Pull the Extension Bar up as far as it will go.
2. Rotate the Thread Guide Hanger so that the Thread Guides are right above the spool pins.
3. Place the spools or thread cones on spool pins.

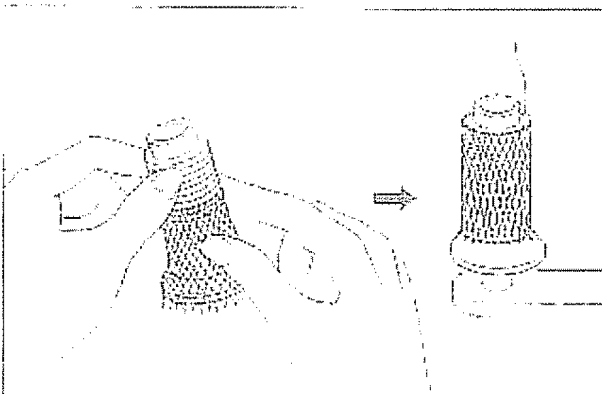
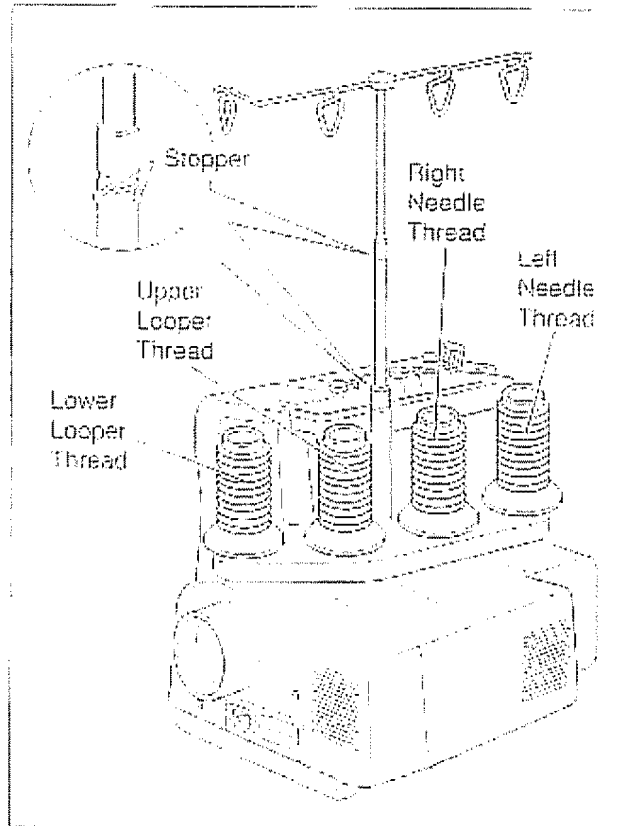

Thread spool nets are useful for synthetic threads which tend to drop off its holder. Cover the thread cones with the thread nets provided with the accessories. Bring thread end to the top of the machine.

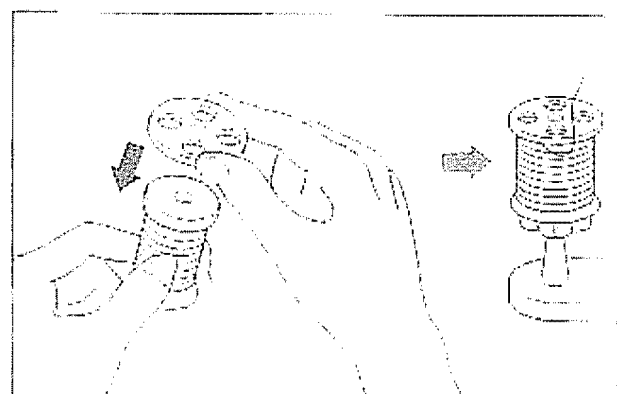

Thread caps are also provided with the accessories. They are used when sewing with regular spools. Insert the stem of cap into the spool hole opposite the end with notch.

threading the upper looper

Open the front cover and thread upper looper thread as illustrated below in steps 1 to 9
Follow thread guides with green color markings on machine

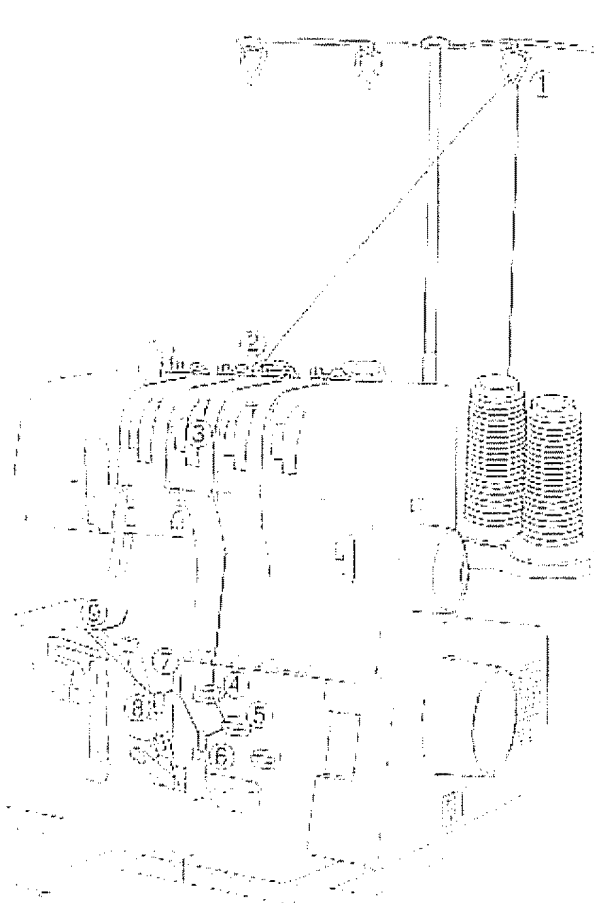

Threading chart

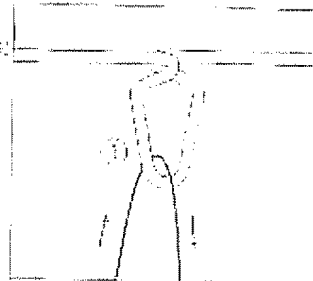

1 Pass thread through top guide from back to front

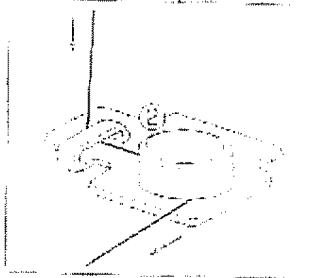

2 Bring thread down and pass through thread guide and under Tension Disc

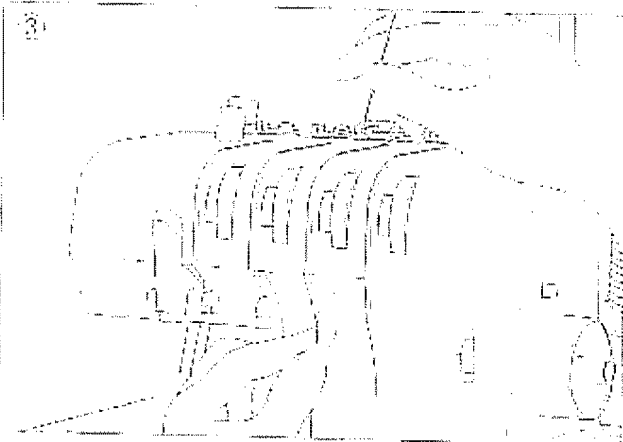

3 Bring thread straight down through the slot so that it passes between the tension discs

4 Hook thread from the left side

5 Hook thread from the right side

6 Hook thread from the bottom side and pull thread up.

7 Hook thread from the top side

8 Hook thread from the bottom side and pull thread up

9 Use tweezers to pass thread through the upper looper hole front to back. Pull at least 7 cm (8 inches) of thread through the upper looper

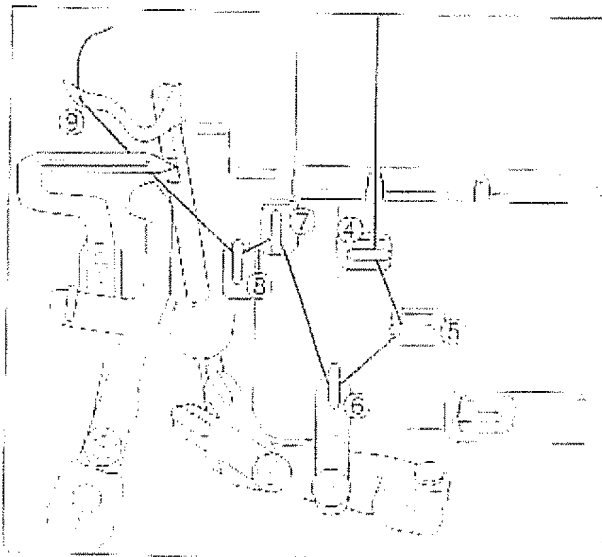

threading the lower looper

Swing the extension table, with free arm attached, out to the left. Thread lower looper thread as illustrated below in steps A to H. Follow thread guides with blue color markings on machine.

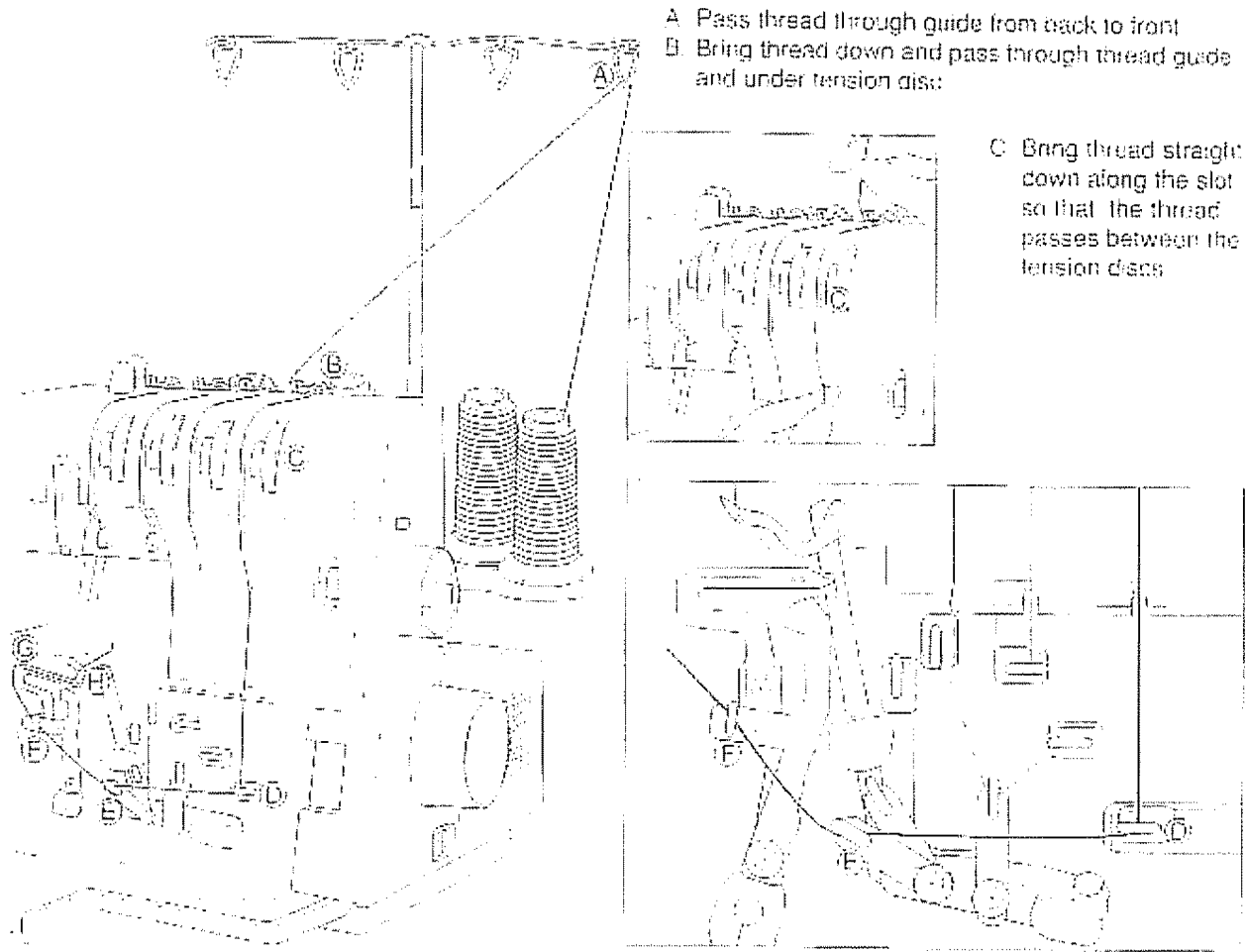

- A Pass thread through guide from back to front
- B Bring thread down and pass through thread guide and under tension disc

- C Bring thread straight down along the slot so that the thread passes between the tension discs

- D Hook thread from the right side and pull thread towards left
- E Hook thread from the bottom side
- F Hook thread from the bottom side and pull thread towards left

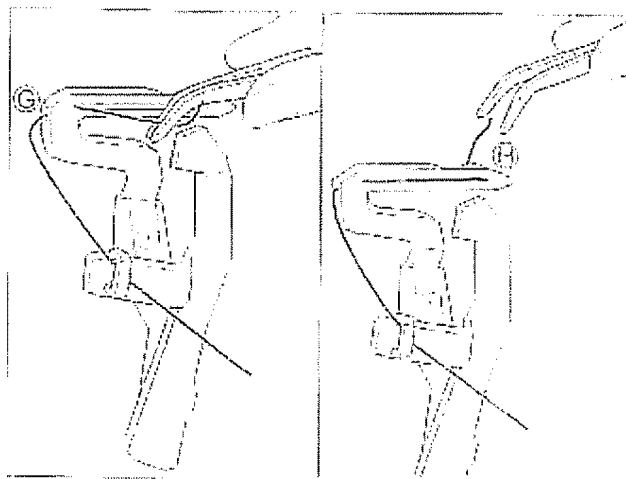

- G Turn hand wheel towards you until the lower looper is in extreme left side position. Pass thread through hole using the tweezers.
- H Turn hand wheel until the lower looper is in extreme right position. Use the tweezers to pass thread through hole front to back. Pull at least 7 cm (3 inches) of thread through lower looper.

threading the right and left needles

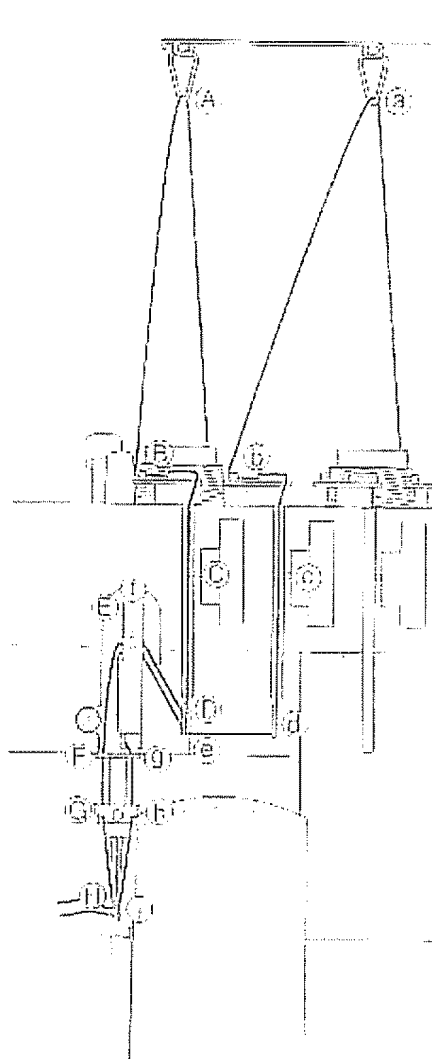

Thread right needle as illustrated below in steps a to i
Thread guides with yellow color marking on machine

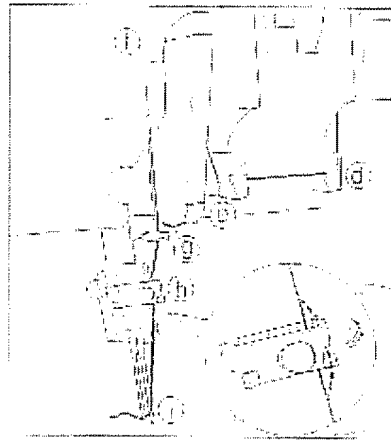

- a-c Thread same sequence as threading upper and lower looper thread
- d Hook thread into guide and pull it towards left.
- e Hook thread into back opening of guide
- f Hook into guide by sliding thread across top and down into hole.
- g Hook thread into right side opening of guide.
- h Pass thread through guide
- i Pass through needle eye front to back. Pull at least 7 cm (3 inches) of thread through the needle eye

Thread left needle as illustrated below in steps A to H
Thread guides with red color marking on machine

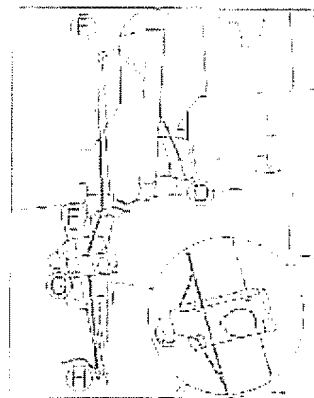

- A-C Thread same sequence as threading upper and lower looper thread
- D Hook thread into front opening of guide and pull thread up.
- E Hook into guide by sliding thread across top and down into hole
- F Hook thread into left side opening of guide
- G Pass thread through guide
- H Use the tweezers to pass through the needle eye front to back. Pull at least 7 cm (3 inches) of thread through the needle eye

easy thread changing -Tying On method

- 1 Cut the thread near the spools.
- 2 Exchange the spool with a new one and tie end to remaining thread making knot as small as possible
- 3 Note the numbers on each Thread Tension Dial.
- 4 Turn Thread Tension Dials to the smallest number.
- 5 Press Foot Control and run machine until upper and lower thread knot comes through looper hole
- 6 Stop needle thread knot before passing through eye of needle. Pull needle threads near the needle eye and cut thread knots
- 7 Pass threads through needle eye manually
- 8 Return tension dials to original tension settings.

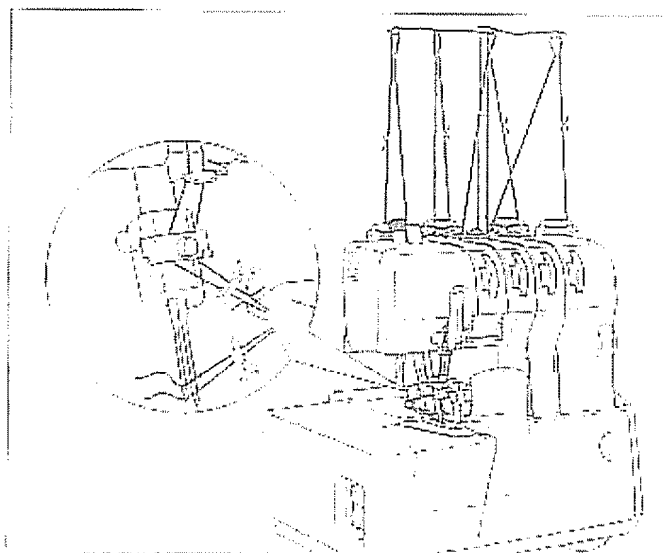

BEFORE STARTING TO SEW

When the machine is plugged in properly and threaded correctly it is ready for sewing. To insure good stitches make several sewing tests using the same fabric and thread on which you will sew. Make the proper adjustments while test sewing.

starting to sew

1. Pull all threads under the presser foot and toward the back.
2. Lower the presser foot.
3. Turn hand wheel towards you 2 or 3 times and check the thread chain.
4. Press Foot Control lightly pulling threads towards back and make thread chain about 5 cm (2 inches).
5. Place a scrap of fabric under the toe of the presser foot at the position to be stitched.
6. Hold end of thread with your left hand when starting to sew.

presser foot markings

The markings on the front of the presser foot line up directly in front of the needles for guiding your fabric.

- Left mark for the left needle.
- Right mark for the right needle.

The toe opening in the presser foot is designed to guide a stabilizing tape, narrow elastic or decorative ribbon into the stitching.

Insert the tape or elastic into the slot and under the back of the foot.

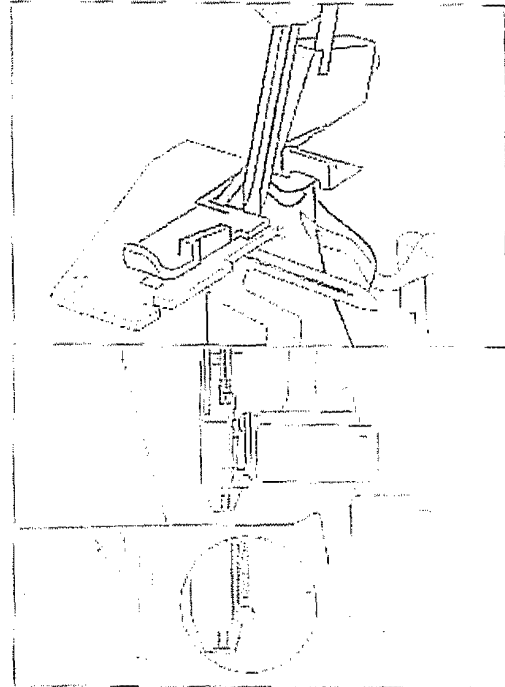

end of seam

1. When the needle reaches the end of seam, chain off by running the machine until the thread chain is 6-7 cm (2-3 inches) long.
2. Stop the machine and cut the thread chain remaining 3-4 cm (1-2 inches) to the machine. Tie small knots in thread ends and treat with dot of seam sealant. Let dry and trim close to knot.
3. For neater finish, pull thread ends back through seam using hook or yarn needle.



when thread breaks

If the thread breaks while sewing, remove fabric from machine and rethread as indicated below.

- Upper Looter Thread: turn hand wheel towards you until the upper looper is in the lowest position. Pass thread through the looper hole.
- Lower Looter Thread: cut the needle threads near needle hole; rethread the lower looper; rethread the needle/needles.

To begin sewing, place material 3-4 cm (1-2 inches) behind point where thread broke.

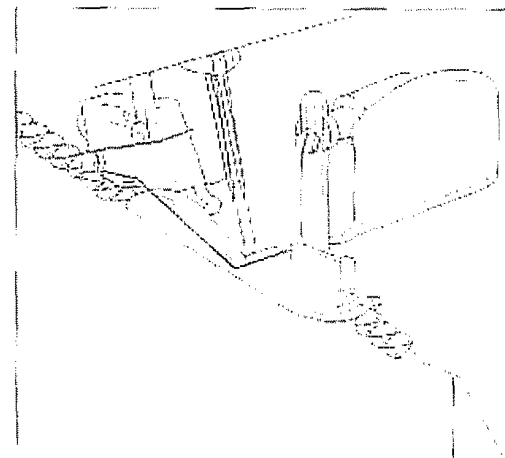

OVERLOCK SEWING (2-needle, 4-thread)

Your machine will sew overlock stitches and simultaneously trim the fabric. It is delivered from the factory preset to sew a 4-thread overlock stitch.

This machine can also sew 1-needle, 3-thread overlock stitch by removing one needle. (See page 13 'OVERLOCK SEWING 1-needle, 3-thread'.)

The 2-needle, 4-thread stitch offers a stronger seam for some areas of your sewing. It is recommended for most woven fabrics and clothes that will receive harder wear and/or frequent washings.

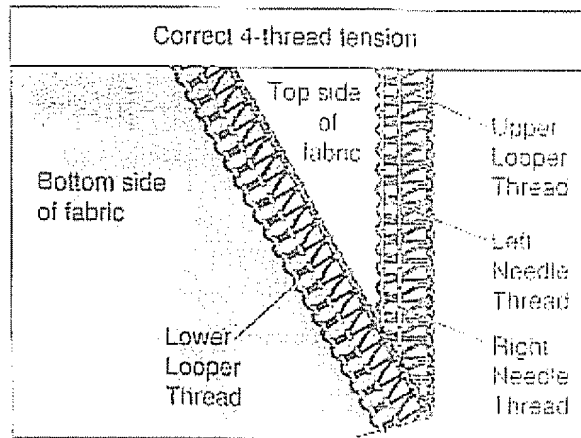

FOUR THREAD TENSION

The stitch quality depends on proper balance between the four thread tensions. The tensions may require adjustment depending on the type of fabric, heaviness of fabric and size of thread used.

The table below is a guide for adjusting the thread tension. Note: Be sure that the thread is passing between the tension discs.

Fabric	Left Needle Thread	Right Needle Thread	Upper Looper Thread	Lower Looper Thread
Light Weight	2.5-4.5	1.5-3.5	2.0-4.0	2.0-4.0
Medium Weight	2.5-4.5	1.5-3.5	2.0-4.0	2.0-4.0
Heavy Weight	2.5-4.5	1.5-3.5	2.0-4.0	2.0-4.5

NOTE:
This table is a guide for thread tensions when sewing with #60 to #90 polyester spun threads.

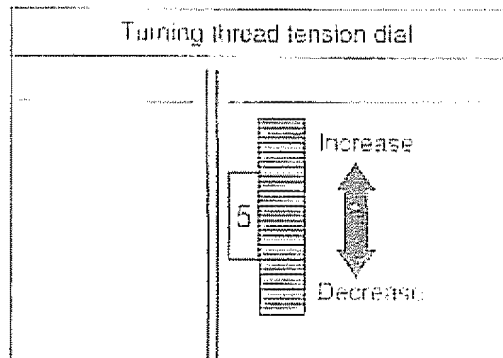
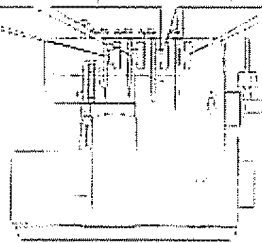

TO INCREASE, turn tension dial to a higher number.
TO DECREASE, turn tension dial to a lower number.

The charts below are illustrations of stitches needing adjustment in the thread tension.

Left needle thread is too loose. (Clearly visible on the bottom side of fabric.)	Right needle thread is too loose.	Upper looper thread crossed on bottom side of fabric.	Lower looper thread crossed on top side of fabric.
Increase Left Needle Thread Tension and/or Decrease Upper and Lower Looper Thread Tensions	Increase Right Needle Thread Tension	Increase Upper Looper Thread Tension and/or Decrease Lower Looper Thread Tension.	Increase Lower Looper Thread Tension and/or Decrease Upper Looper Thread Tension

SETTING STITCH LENGTH

The stitch length can be adjusted between 1 and 4 mm

- For shortest stitch, turn dial to 1. (fig 12-A)
- For longest stitch, turn dial to 4

As a rule, light weight fabrics take a shorter stitch
Heavy weight fabrics need longer stitches
Most normal sewing is done with stitch length dial set at 3. This produces a medium length stitch which makes a strong seam and is suitable for most fabrics

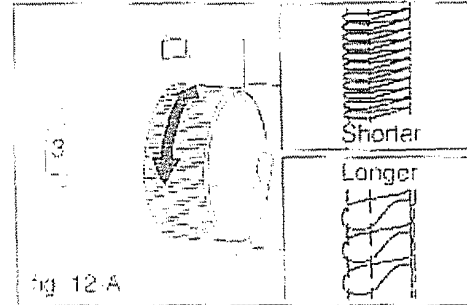

ADJUSTING THE DIFFERENTIAL FEED

This machine has two feed dogs - a front feed dog and a rear feed dog - which move independently and can be adjusted separately. This Differential Feed prevents waving in stretch fabrics and insures pucker-free seams in light weight woven fabrics

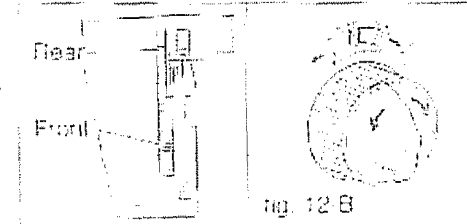

The rear feed motion (main feed) is adjusted by turning the stitch length regulator dial. The front feed motion is adjusted by turning the differential feed regulator dial which is located inside the stitch length regulator dial (fig 12-B)

- For normal sewing, set the differential feed regulator dial to '1'. Both feed dogs will move together and feed evenly
- For pucker-free seams in delicate or closely woven fabrics, turn the dial to '0.7'. The front feed dog motion will be shorter than the rear feed dog motion. The front feed dog will hold back the fabric, enabling the rear feed dog to take it up behind the needle without any puckering. (fig 12-C)
- When sewing stretch or knit fabrics, turn the dial towards '2'. The front feed dog motion will be longer than the rear feed dog motion and in this manner the fabric can be sewn without stretching. (fig 12-D)

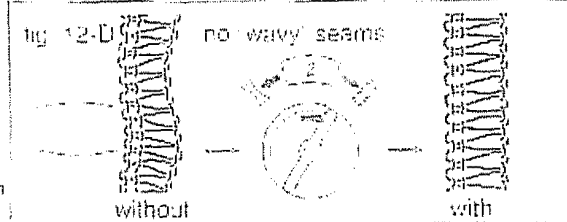
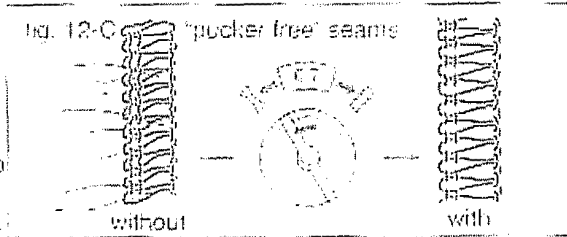

- The differential feed can be used for gathering or lettuce edging
- For gathering, set the dial towards '2' (fig 12-E)
- For lettuce edging, set the dial towards '0.7' (fig 12-F)

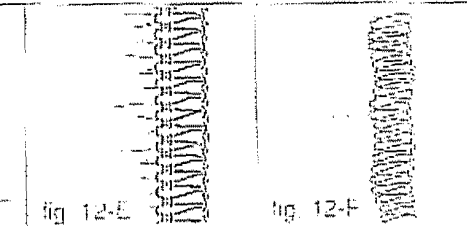

SETTING THE SEAM WIDTH

Overedge seam width can be adjusted from 6.2 mm (right needle 4.0 mm) to 7.2 mm (right needle 5.0 mm) stitch. Normally the machine is set at 6.2 mm which is the width most frequently used.
For heavy weight fabrics, set control knob to wider stitch.

1. Turn power switch off.
 2. Open front cover and Free Arm Cover.
 3. Push the Upper Blade Holder to the right and turn the Width Indicator Knob downward to select wider stitch width. For smaller width turn knob in opposite direction.
- When adjusting the width, use the markings on the needle plate as guide and line up with left edge of lower blade width indicator.
- The numbers marked on the needle plate are the width to the right needle, and the distance between needles is 2.2 mm. Therefore the width to left needle is an additional 2.2 mm

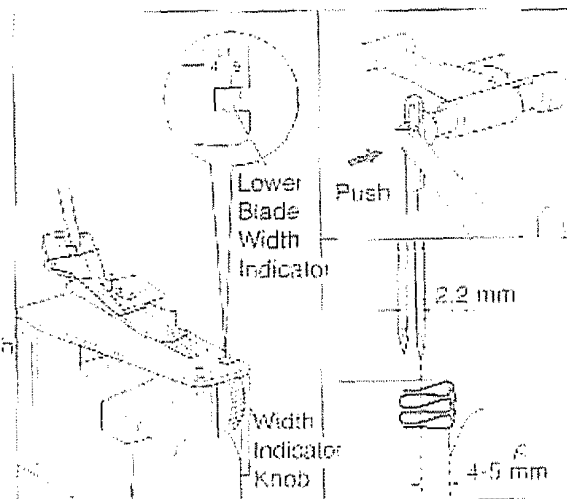

ADJUSTING THE PRESSURE ON FABRIC

The pressure on the foot can be adjusted for different weight fabrics. The fabric should move along smoothly and evenly without slipping. Stitches should be uniform in size.

The pressure on this machine is set for sewing medium weight fabrics.

- For sewing light weight fabrics, decrease the pressure (turn screw to left).
- For heavy weight fabrics, increase the pressure (turn screw to right).

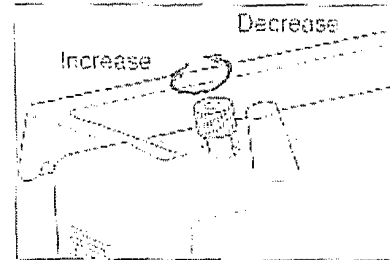

OVERLOCK SEWING (1-needle, 3-thread)

This machine can also sew 1-needle, 3-thread overlock stitching by removing either needle, depending on the seam width you desire.

This is the standard overlock stitch and is suitable for most fabrics.

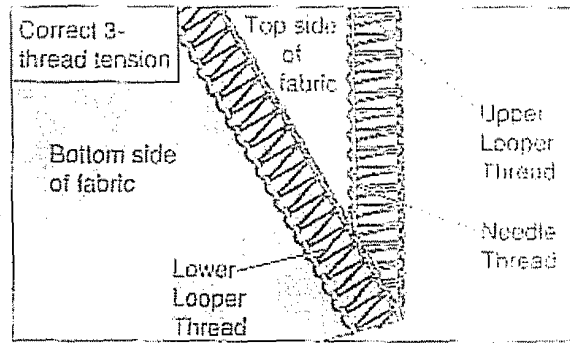

To convert your machine to a wide 3-thread stitch (7.2 mm - 6.2 mm), snip the right needle thread just above the eye of the needle. Remove the thread from the "yellow" color coded thread guides. Remove the right needle and tighten the right needle clamp screw. This stitch width is suitable for sewing heavier fabrics.

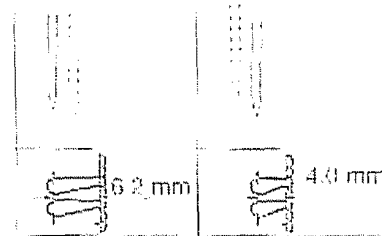

To convert your machine to a narrow 3-thread stitch (5 mm - 4 mm), snip the left needle thread just above the eye of the needle. Remove the thread from the "red" color coded thread guides. Remove the left needle and tighten the left needle clamp screw. This stitch width is suitable for sewing lightweight to medium weight fabrics.

Both seam widths can be adjusted by turning the width indicator knob. (See page 12: SETTING SEAM WIDTH.)

Fabric Weight	Needle Thread (Left or Right)	Upper Looper Thread	Lower Looper Thread
Light	(Left)	2.0-4.0	2.0-4.0
	(Right)	1.5-3.5	2.5-5.0
Medium	(Left)	2.0-4.0	2.0-4.0
	(Right)	1.5-3.5	2.5-5.0
Heavy	(Left)	2.5-4.5	2.0-4.0
	(Right)	1.5-3.5	2.5-5.0

three thread tension

Use the chart to the right as a guide in setting tension. Note: Be sure that the thread is passing between the tension discs.

NOTE:
This table is a guide for thread tensions when sewing with #60 to #90 polyester spun threads.

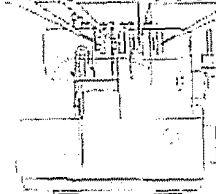

The illustrations below are examples of stitches which need adjusting.

Needle thread is too loose. (Clearly visible on the bottom side of fabric.)	Upper looper thread crossed on bottom side of fabric.	Lower looper thread crossed on top side of fabric.
Increase Needle Thread Tension and/or Decrease Upper and Lower Looper Thread Tension	Increase Upper Looper Thread Tension and/or Decrease Lower Looper Thread Tension	Increase Lower Looper Thread Tension and/or Decrease Upper Looper Thread Tension

NARROW AND ROLLED HEMMING

By changing the needle plate to "Rolled Hem Needle Plate" and using right needle only, the machine trims fabric, folds back the edge and sews a narrow hem (overedge). The width of the narrow overedge is 1.5 mm (about 1/16") and is used for overedging light and medium weight fabrics.

Two variations of the rolled overedge hem can be sewn with this machine by changing the thread tension. Both methods are used with light and medium weight fabrics. Method B gives a softer finish by pulling the interlocking threads to the wrong side.

changing the needle plate

The machine comes with a standard overedge needle plate set to the machine. Change the needle plate when sewing rolled overedge.

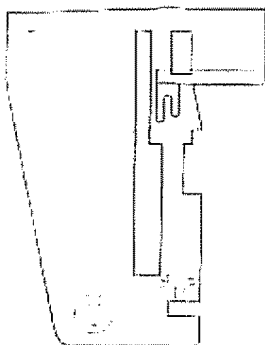

Standard Overedge
Needle Plate

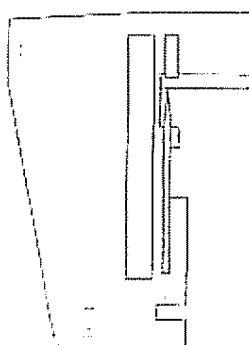

Rolled Hem
Needle Plate

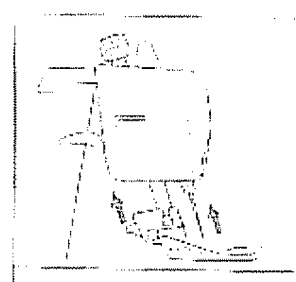
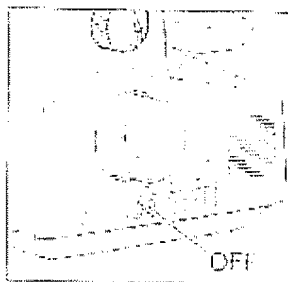

- 1 Turn power switch off
- 2 Turn hand wheel toward you until needle is at its highest point
- 3 Lift presser foot bar.
- 4 Clear stitches off the stitch fingers

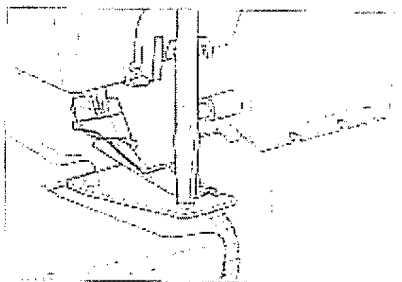

- 5 Open Extension Table and Free Arm Cover (See page 3)
- 6 Loosen the front side screw

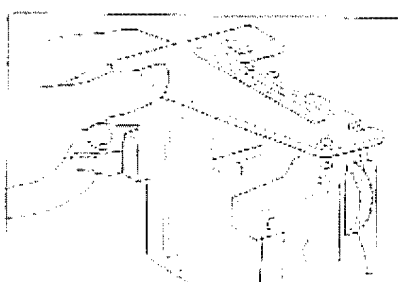

- 7 Lift the Needle Plate off and replace with Rolled Hemming Plate. (Be sure that thread is not caught under plate.)

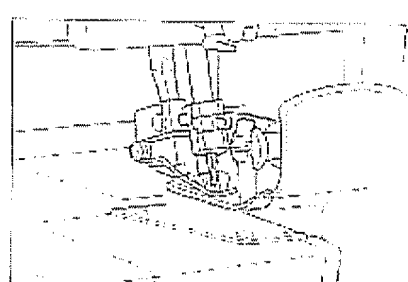

- 8 Retighten the screw and replace Free Arm Cover

setting controls

Set the controls as follows:

- 1 Use right needle only. (Remove the left needle.)
- 2 Fabric, Thread & Needle Size
Refer to Page 5 "NEEDLE, THREAD & FABRIC CHART", for selecting suitable thread and needle sizes for sewing on light and medium weight fabrics.
- 3 Stitch Length Regulator
Set stitch length between 1 and 2 mm.
- 4 Width Indicator Knob
The seam width for sewing rolled overedge is normally 1.5 mm (about 1/16").
Turn width indicator knob and adjust so that the left side of Lower Blade Width Indicator is aligned with the mark of the Rolled Hem Needle Plate. (See page 12).

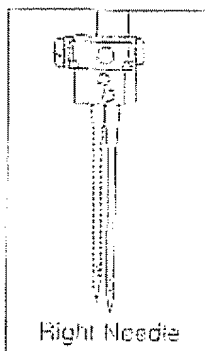

Right Needle

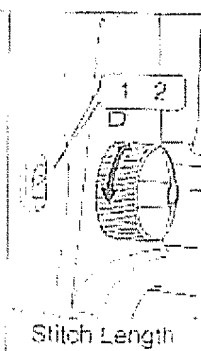

Stitch Length

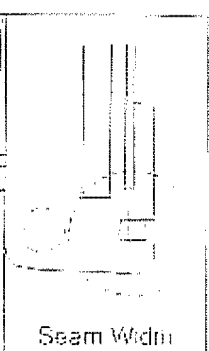

Seam Width

sewing

Pull the excess threads gently toward the back and begin sewing. Although the stitch width is set at 1.5 mm, you will actually need 3.5 mm (about 1/8") to provide enough fabric for the fold back.

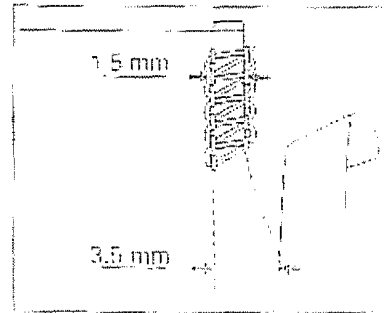

thread tension -Method A

Use the chart below as a guide in setting tension. The tension adjustments for Method A are the same as 1-needle, 3-thread overlock. See page 13 if adjustments are needed.

Fabric	Needle Thread (Right)	Upper Loper Thread	Lower Loper Thread
Light & Medium	1.5-3.5	2.0-4.0	2.0-4.0

NOTE:
This table is a guide for thread tensions when sewing with #80 to #90 polyester spun threads.

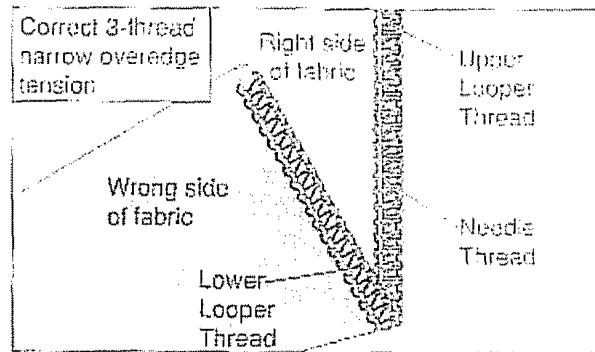

ROLLED OVEREDGE -Method B

The upper looper thread encases the edge fabric in Method B rolled overedge hem creating a softer finish. Settings and sewing of Method B rolled overedge hem are the same as the Method A rolled overedge except for thread tension. (See below)

thread tension -Method B

Regulate the tension dials using guide below

Fabric	Needle Thread (Right)	Upper Loper Thread	Lower Loper Thread
Light & Medium	1.5-3.5	2.0-4.0	4.0-7.0

NOTE:
This table is a guide for thread tensions when sewing with #80 to #90 polyester spun threads.

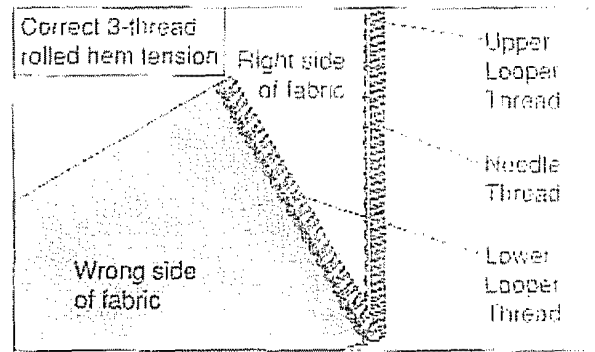
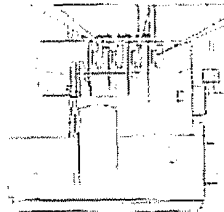

Needle thread is too loose.	Upper looper thread is too loose.	Lower looper thread is too loose.
Increase Needle Thread Tension and/or Decrease Upper Thread Tension.	Increase Upper Loper Thread Tension.	Increase Lower Loper Thread Tension and/or Decrease Upper Loper Thread Tension.

TWO THREAD SERGING

Two thread serging provides a decorative, yet functional seam known as the flatlock seam. You can flatlock garments ranging from lingerie to fake fur coats. When sewing with two threads you can achieve a flat, bulk-free seam. Using it to seam fake-fur fabrics and hand knit fabrics you will find that the "stitches" disappear into the nap. Enhance the appearance of flatlock stitch with the use of decorative threads through the looper.

Besides flatlock seaming, two thread serging also provides a sturdy means of overedging all fabrics.

This can be combined with specialty threads for decorative edges on ruffles, hemlines, and borders.

Two thread sewing is accomplished through the elimination of two threads: the upper looper and either needle. **NOTE:** Use the **LEFT** needle for a wide flatlock stitch; use the **RIGHT** needle for a narrow flatlock stitch.

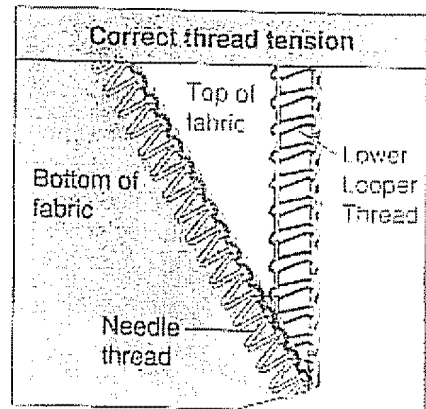

Needle and lower looper threads are crossing on the edge of fabric.

to convert from 3-thread to 2-thread sewing

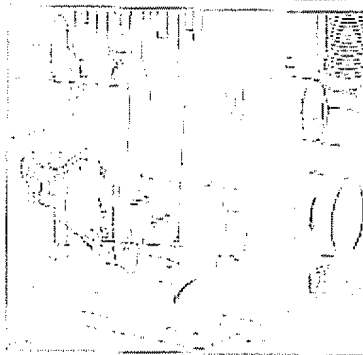

1. Open the front cover and rotate the handwheel to bring the upper looper to its lowest position.

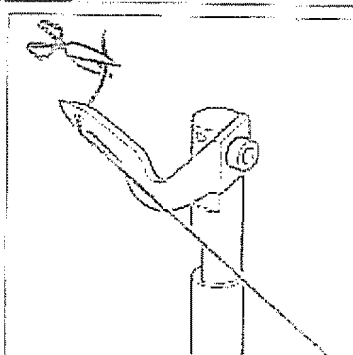

2. Cut the upper looper thread just behind the eye of the upper looper.



3. Remove the lower looper thread from the thread guide (A).

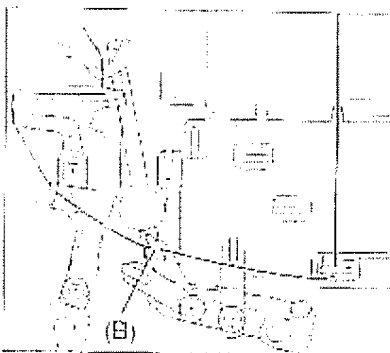

4. Hook the lower looper thread to the thread guide (B).

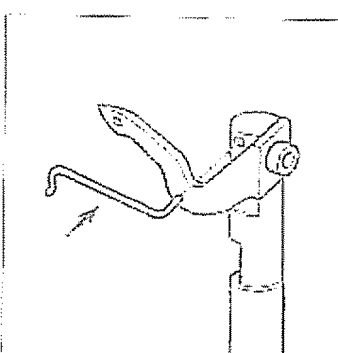

5. Insert the subsidiary looper into the hole at the top of the upper looper shaft.

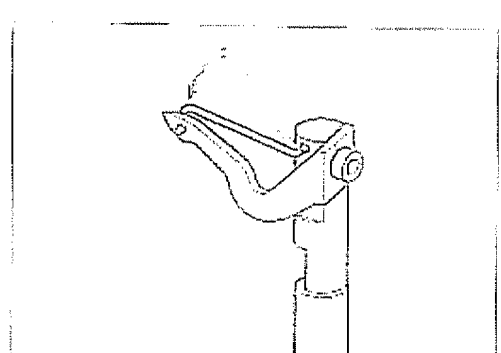

6. Push on the subsidiary looper with your finger and rotate it to the left until the tip of the subsidiary looper is securely positioned into the eye of the upper looper.

thread tension

When you are doing two thread serging for the first time use a medium weight fabric to sew a test sample for determining the correct tension setting. Begin by adjusting the needle tension to "1" and the lower looper tension to "4". Sew a sample. If the threads are not balanced make necessary adjustments according to the illustrations.

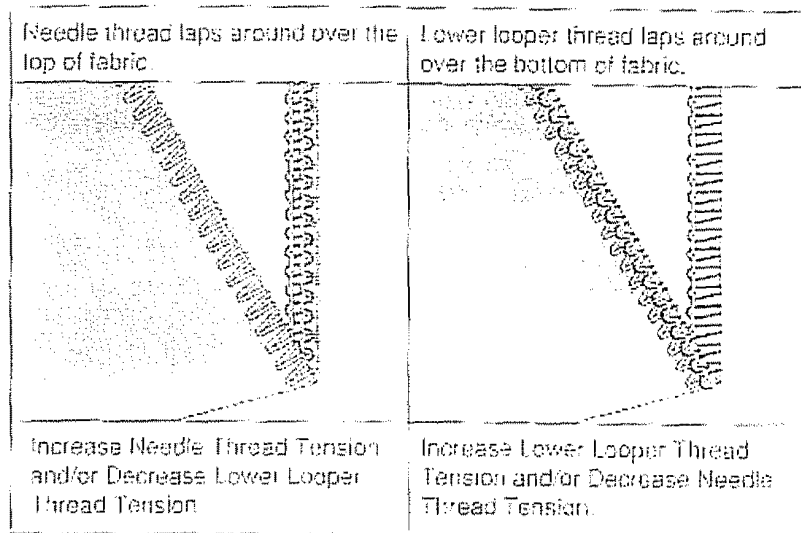

to convert from 2-thread to 3- or 4- thread sewing

1. Open the front cover and bring the upper looper to its lowest position
2. With your finger, push back on the subsidiary looper and rotate clockwise (up) to disengage from the eye of the upper looper.
3. Remove subsidiary looper from the upper looper shaft and place in accessory box
4. Remove the lower looper thread from the thread guide (B) and hook to the thread guide (A).
5. Re-thread upper looper thread guides which may have been unthreaded and back through the eye of the upper looper
6. For four thread sewing, replace the second needle and its corresponding thread.
7. Rebalance tensions - tighten needle thread, re-adjust lower looper if necessary

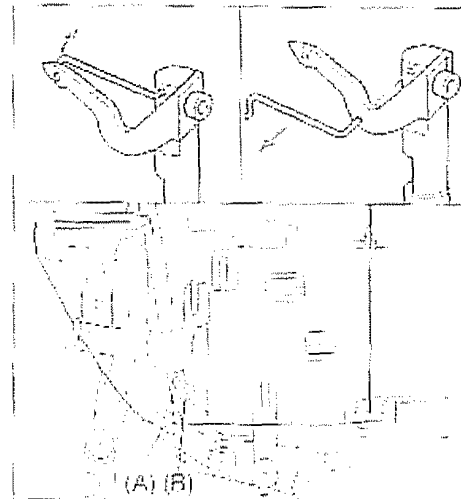

FREE ARM SEWING

This machine will convert to free arm sewing by simply opening the Extension Table. It is used for sewing sleeves, trousers or similar places that are difficult to sew on a flat bed machine.

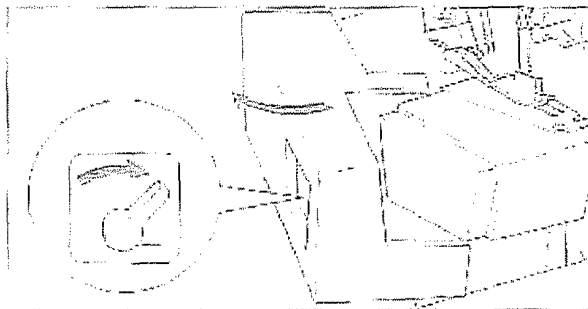

Turn lever located on left side of extension table to the front of machine and swing table out

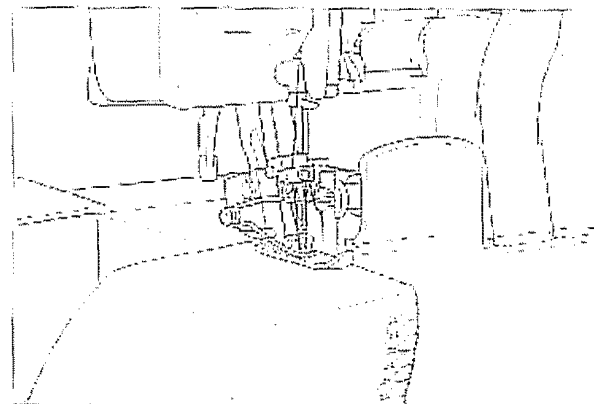

BLIND HEMMING

By changing the presser foot to 'Blind Hem Presser Foot', you can sew blind stitches while trimming fabric. It produces a durable hem which is almost invisible on the right side of the article sewn. It is useful for sewing cuffs, trouser bottoms, pockets etc..

changing the presser foot

REMOVING THE PRESSER FOOT

1. Turn the hand wheel towards you until the needle is at its highest point.
2. Lift up the presser foot by raising the presser foot lifter.
3. Push the presser foot releasing lever towards you, and presser foot will disengage.
4. Pull up the presser foot spring and remove the presser foot.

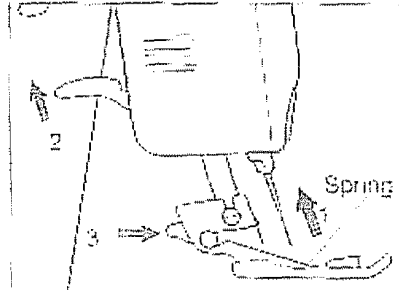

REPLACING THE PRESSER FOOT

1. Pull up the presser foot spring and place the presser foot below the presser foot holder so that the pin on the foot fits into the hollow of presser foot holder.
2. Lower the presser bar with the presser foot lifter and the presser foot will snap into place.

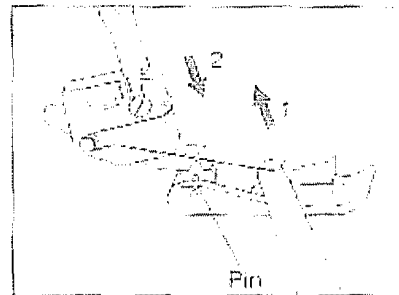

setting controls

Attach the blind hem presser foot and remove the left needle (leave the right needle). Set the machine to sew 1-needle, 3 thread overlock and adjust the thread tensions as shown on the right.

Turn tension dials for normal 3-thread overlocking.

Needle Thread (Right)	Upper Loper Thread	Lower Loper Thread
Slightly Decrease	Slightly Increase	Slightly Decrease

Needle	Stitch Length
Right	3 - 4
Presser Foot	Needle Plate
Blind Hem	Standard
	Seam Width
	4

sewing

First sew a test sample on a scrap of fabric and adjust the seam guide and thread tension.

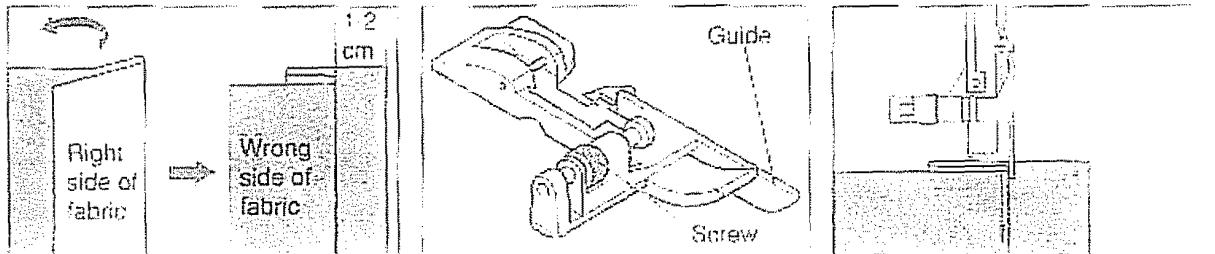

1. Fold hem up as desired, fold it back toward right side of the fabric. Leave 1 to 2 cm seam allowance to the right.
2. The plastic guide on the presser foot ensures even leading of the fabric when blind hemming. This guide is adjusted by turning the screw.
3. Raise the presser foot.
4. With the wrong side up, place the fabric under the presser foot so that the plastic guide is just touching the folded edge.
5. Adjust the guide so that the needle pierces just the folded edge.

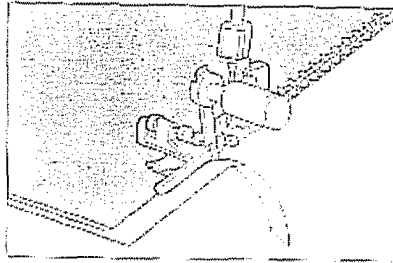

6 Lower the presser foot and sew hem, guiding fabric evenly along the plastic guide.

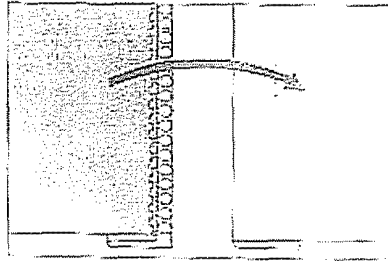

7 When hem is completed, open the fabric and press hem

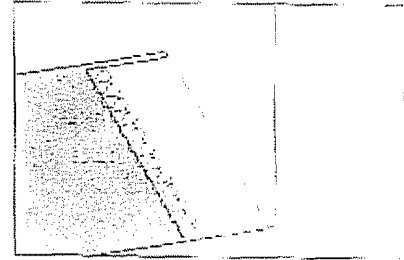

CORRECT THREAD TENSION
The upper and lower looper threads are crossed on the cut edge of fabric

SEWING WITH UPPER BLADE DISENGAGED

When sewing without trimming, disengage the moving blade as shown below.

Use the blind hem presser foot to insure even seam width.

NOTE: When using the blind hem foot, always remove the left needle.

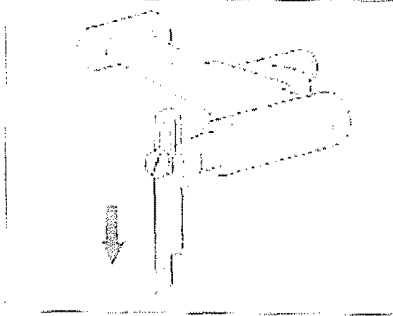

1 Unplug the machine.
2 Open the front cover.
3 Turn hand wheel towards you until the upper blade is at its lowest point.

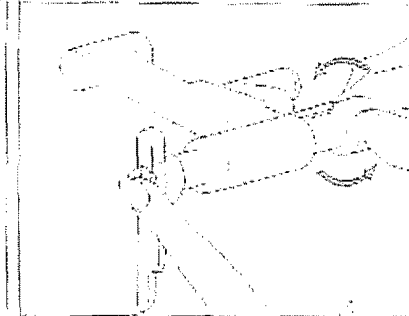

4 Push the upper blade to the right as far as it will go and turn knob in opposite direction until it clicks into position.
5 To re-engage, push blade holder to right and turn blade towards you until it clicks into position.

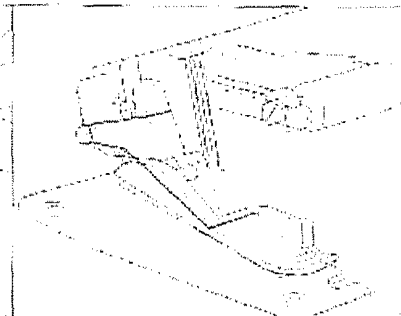

sewing

Adjust the plastic guide by turning the screw so that the stitches are just over the folded edge.

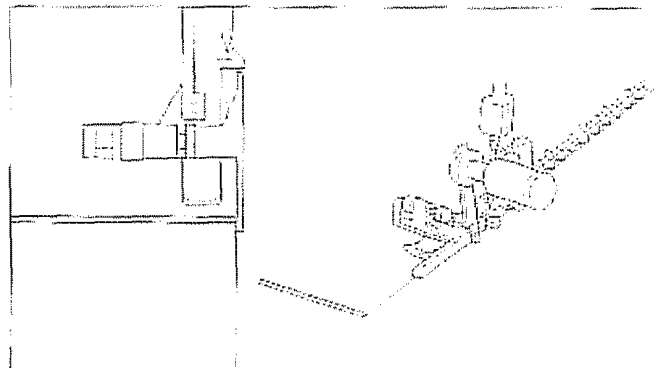

FLATLOCK SEAM

Using the blind hem presser foot and disengaging the upper blade, you can sew decorative top stitching "Flatlock Seam" as shown on the sketch:

setting controls

Set the machine controls as below:

Needle	Right
Presser Foot	Blind Hem

Stitch Length	2-3
Upper Blade	Disengage
Needle Plate	Standard

Flatlock Seam (Correct thread tension)

thread tension

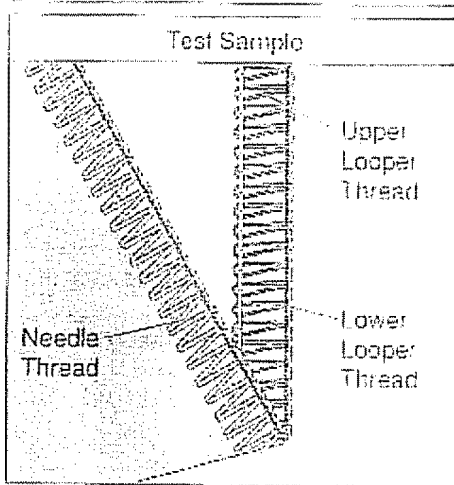

Turn tension dials for normal 3-thread overcasting		
Needle Thread (Right)	Upper Loper Thread	Lower Loper Thread
Decrease	-	Increase

1. First sew test sample for adjusting the thread tensions
 2. Fold fabric with wrong sides together
 3. Adjust the plastic guide so that the stitches just overcast the folded edge
 4. Adjust the thread tensions until the needle thread comes to folded edge and the lower looper thread forms nearly a straight line on the edge
-

sewing

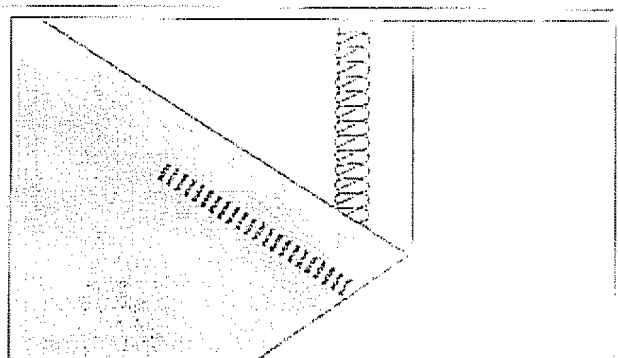
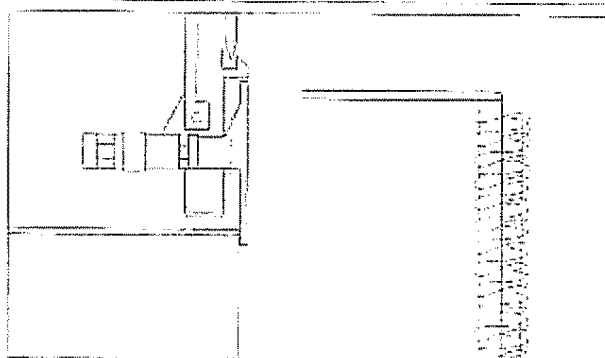

1. Fold fabric with wrong sides together
2. Adjust the plastic guide so that the stitches hang halfway over the folded edge
3. Lower the presser foot and sew
4. When stitching is completed, pull fabric flat and press the stitches from the wrong side of fabric

PIN TUCKING

Pin tucking is a useful decorative stitch for blouses and children's wear.

Set the machine controls as shown on the right.

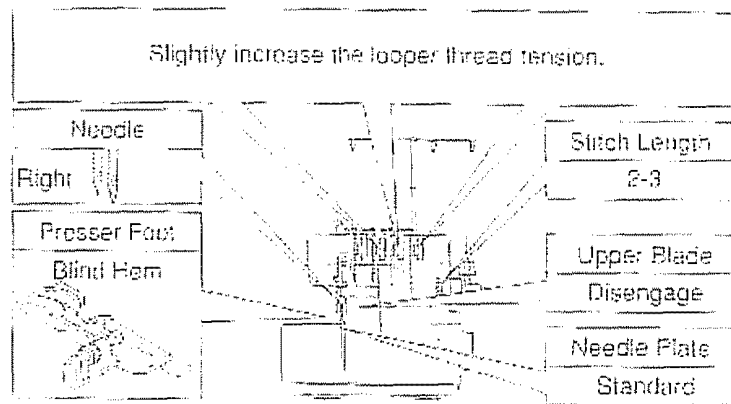

sewing

1. Fold fabric with wrong sides together
2. Adjust the plastic guides so that the stitches just overcast the folded edge.
3. Lower the presser foot and sew.
4. Sew as many rows as desired and press them to lay flat on one side.

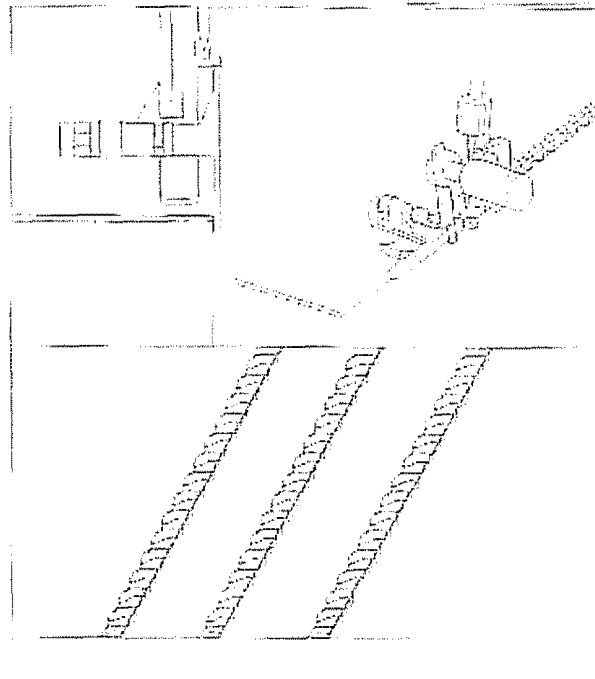

ELASTIC FOOT

(Optional on certain models)

The Elastic foot stretches the elastic as it attaches the elastic to fabric.

The large screw (A) on the front of the foot determines the amount of stretch on the elastic.

1. Attach the elastic presser foot (see page 18 for changing presser foot).
2. Turn the large screw (A) counter clockwise to loosen the upper plate for inserting elastic.
3. Insert the elastic under the plate (B) and under the foot so the elastic extends back under the length of the foot.
4. Tighten the upper plate slightly by turning the large screw (A) clockwise.
5. Stitch an inch or so to be sure the elastic is feeding properly.
6. Insert the fabric at the toe of the foot and serge.

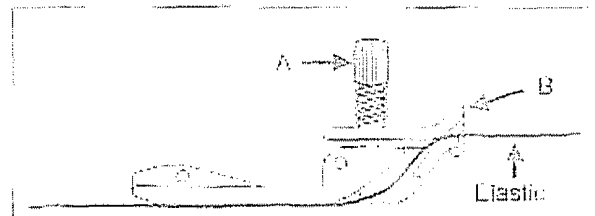

Tighten the screw (turn clockwise) to increase the stretch of the elastic as you serge.

Loosen the screw (turn counter clockwise) to decrease the stretch of the elastic as you serge.

Sew a test piece to determine the appropriate setting for your project.

DECORATIVE OVERLOCK

When you change the Upper Looper Thread to heavier thread or yarn, you can produce decorative overlock stitching. Try using various types of thread to create attractive combinations experiment with different tension adjustments to produce a variety of decorative effects

examples:

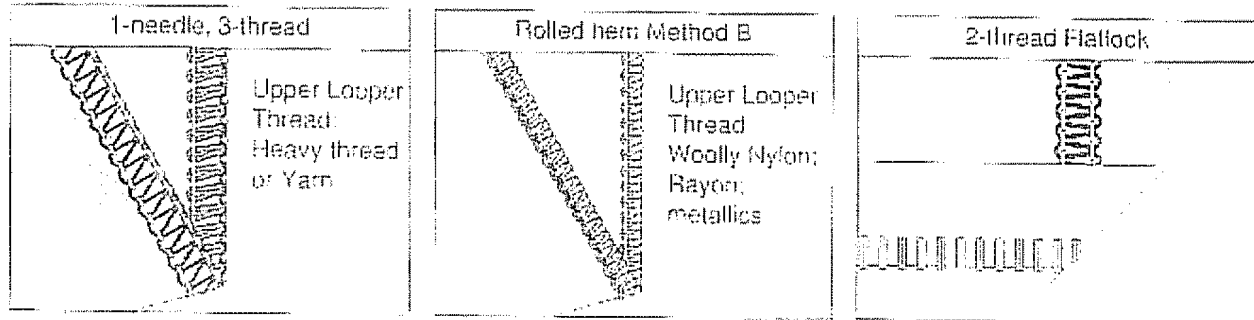

TURNING CORNERS

outside corner

1. Cut the corner about 5-6 cm (2-3 inches) along the cutting line
2. Sew to the end of fabric and stop machine
3. Raise needle and presser foot
4. Pull fabric slightly towards the back and pull out tangled thread from Needle plate
5. Turn fabric and position the fabric by lining up the cut line and blade. Lower the Presser Foot
6. Resume sewing

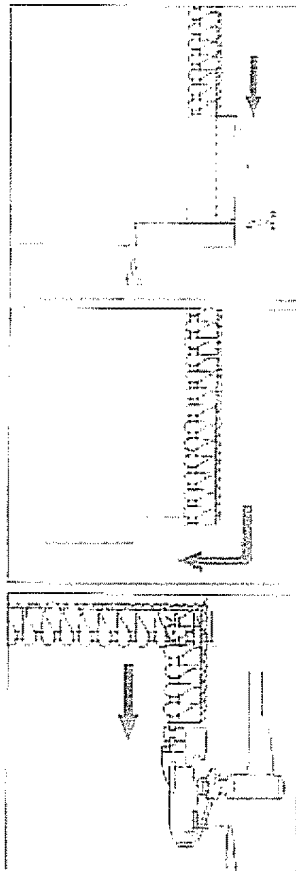

inside corners

1. Snip to corner of seam line
2. Sew desired seam line until blade reaches corner.
3. When you approach the corner, slow down. Lower the needle.
3. Straighten the seam line out in front of the blade. Continue stitching to complete the edge.

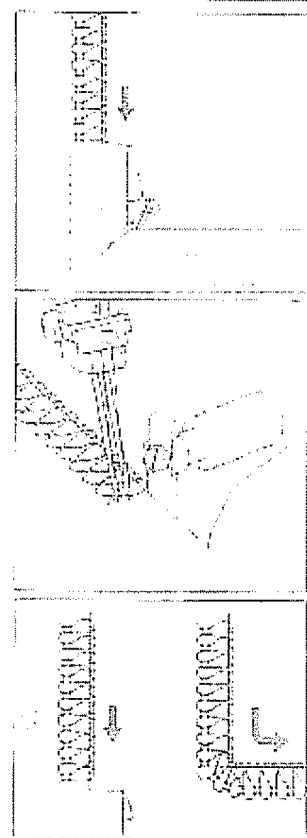

outside curves

The machine can continue sewing when rounding a curve. There is no need to stop the machine and pivot. Push excess fabric toward the presser foot giving the machine more fabric and continue sewing as if sewing a straight seam.



CLEANING AND MAINTENANCE

cleaning

Fabric, thread scraps and dust may accumulate around moving parts and effect the functioning of machine.

Unplug cord and clean machine with the brush provided with the accessories

Brush around the fabric feed dog

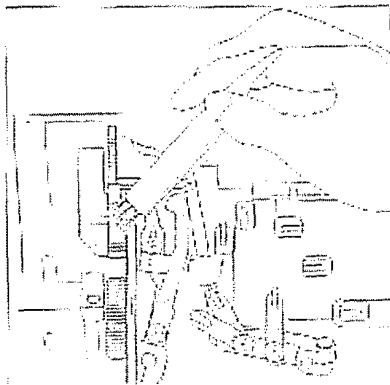

Brush inside of the front cover

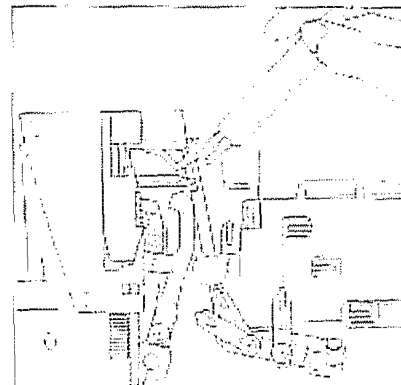

oiling

Critical parts used in this machine are made of special material that does not require oiling. Only the parts indicated with arrows shown below need oiling. Depending on use these should be oiled once or twice a month.

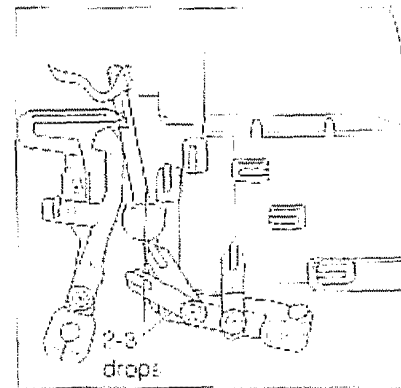
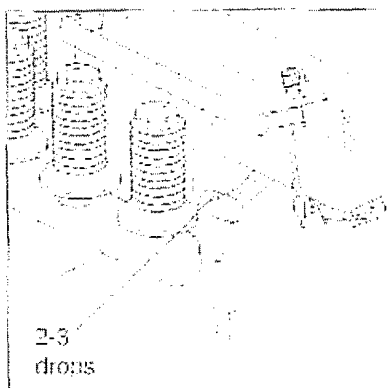

changing the sewing light

If the sewing light does not light when power switch is turned on replace the bulb

1. Unplug sewing machine from the wall receptacle.
2. Remove the Light Cover by loosening the screw.
3. Remove the bulb.
4. Replace with new bulb of same size wattage and size.
5. Replace the Light Cover.

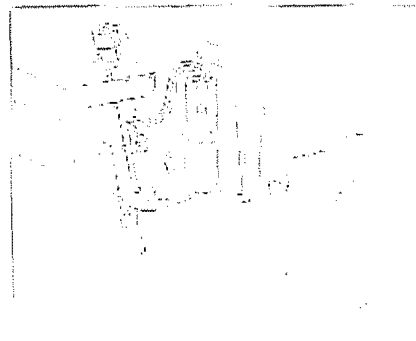

changing the lower blade

Exchange the Lower Blade as shown below when it becomes dull. An extra blade is provided with the accessories.

1. Unplug the machine.
2. Open the front cover.
3. Disengage the upper blade. (See page 19)
4. Loosen the Lower Blade Screw and take out the blade.
5. Install new blade by inserting it into the groove of the blade holder. Be sure that the tip of the lower blade is lined up with the surface of Needle Plate, and tighten screw.
6. Re-engage the Upper Blade to cutting position. Close the front cover.

The upper blade is made of special hard material and should not require replacement under normal use. If it should chip or need replacement, call for your dealer.

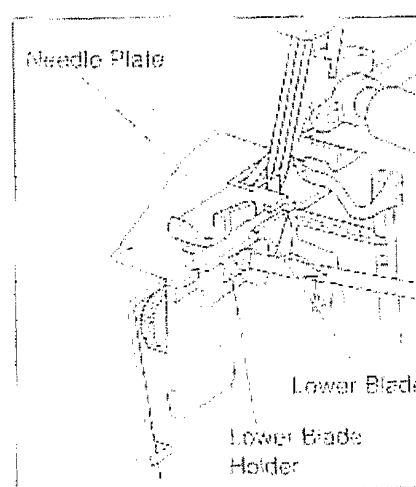

BEFORE YOU CALL FOR SERVICE





Your new serger was carefully inspected and tested at the factory and was in perfect working order when shipped.

Under normal conditions, if you carefully follow instructions for threading, operating and maintenance, your machine will give you years of trouble-free service.

Occasional difficulties are usually caused by a condition that can be easily remedied with a minor adjustment. Some possible problems, their causes and corrections are given here.

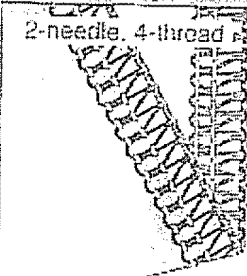
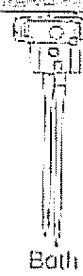
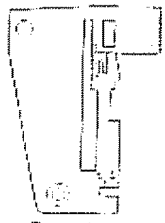
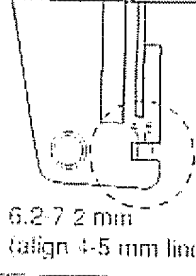
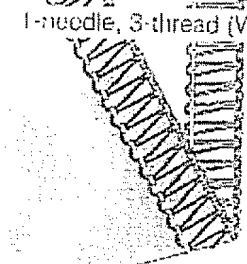
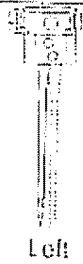
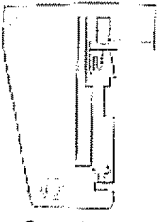
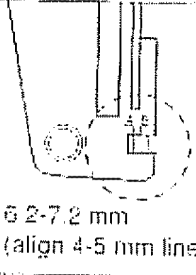
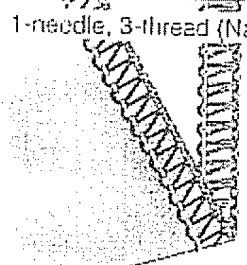
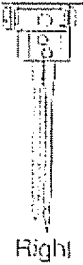
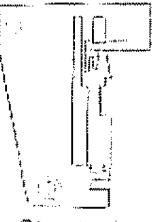
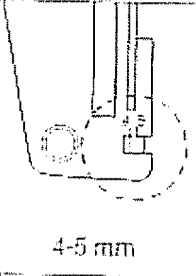
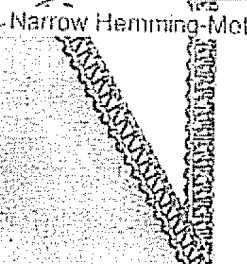
PROBLEM	CAUSE	CORRECTION	REF. PAGE
THREAD BREAKS	<ul style="list-style-type: none"> - Needle inserted incorrectly - Thread tensions are too tight - Bent or blunt needle - Machine not properly threaded - Threads are caught in incorrect guide 	<ul style="list-style-type: none"> Reset needle Loosen thread tensions Insert new needle Rethread machine Rethread machine 	<ul style="list-style-type: none"> 5 11, 13, 15, 17 5 6-9 6-9
MACHINE SKIPS STITCHES	<ul style="list-style-type: none"> - Bent or blunt needle - Needle inserted incorrectly - Pressure on foot insufficient - Incorrect needle size or type - Machine incorrectly threaded - Tensions set too high 	<ul style="list-style-type: none"> Insert new needle Reset needle Increase pressure Insert correct needle Rethread machine Loosen thread tensions 	<ul style="list-style-type: none"> 5 5 13 5 6-9 11, 13, 15, 17
NEEDLE BREAKS	<ul style="list-style-type: none"> - Pulling fabric while sewing - Incorrect size needle or thread for fabric being sewn - Needle inserted incorrectly 	<ul style="list-style-type: none"> Do not pull fabric Choose correct needle and thread Reset needle 	<ul style="list-style-type: none"> 10 5 5
MACHINE DOES NOT FEED PROPERLY	<ul style="list-style-type: none"> - Pressure on presser foot insufficient 	<ul style="list-style-type: none"> Increase pressure 	<ul style="list-style-type: none"> 13
FABRIC PUCKERS	<ul style="list-style-type: none"> - Lower blade is dull - Stitch length not suitable for fabric - Differential feed not suitable - Thread tensions are too tight - Seam width not suitable for fabric 	<ul style="list-style-type: none"> Change lower blade Readjust stitch length Readjust differential feed Loosen thread tensions Readjust seam width 	<ul style="list-style-type: none"> 23 12 12 11, 13, 15, 17 12
LOOSE STITCHES OR LOOPS FORMED	<ul style="list-style-type: none"> - Tensions not adjusted properly 	<ul style="list-style-type: none"> Check thread tensions 	<ul style="list-style-type: none"> 11, 13, 15, 17
MACHINE RUNS HEAVILY	<ul style="list-style-type: none"> - Dirt or lint in stitching mechanism 	<ul style="list-style-type: none"> Clean the machine 	<ul style="list-style-type: none"> 23
MACHINE WILL NOT SEW	<ul style="list-style-type: none"> - Cord not plugged into electrical outlet - Light and power switch not on 	<ul style="list-style-type: none"> Check plug Turn on the switch 	<ul style="list-style-type: none"> 4 4

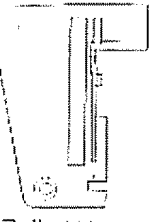
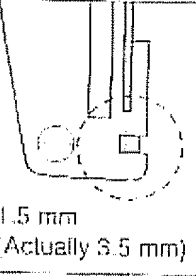
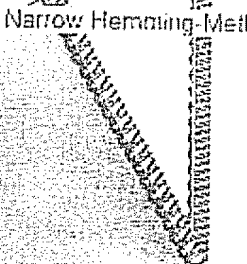
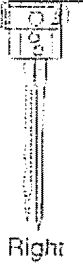
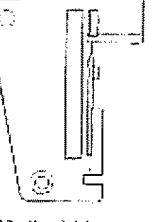
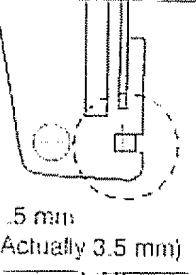
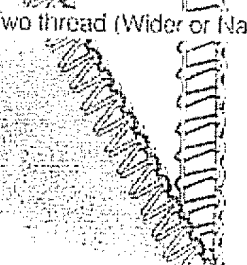
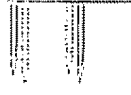
STITCH SELECTION CHART

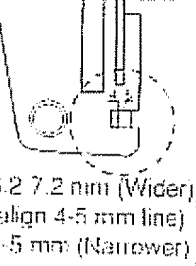
STITCH (Correct thread tension)	NEEDLE	NEEDLE PLATE	SEAM WIDTH	STITCH LENGTH
 <p>2-needle, 4-thread</p>	 <p>Both</p>	 <p>Standard</p>	 <p>6.2-7.2 mm (align 4-5 mm line)</p>	<p>1-4 mm</p> <p>Refer to Page 11 for Tension Adjustment</p>
 <p>1-needle, 3-thread (Wider)</p>	 <p>Left</p>	 <p>Standard</p>	 <p>6.2-7.2 mm (align 4-5 mm line)</p>	<p>1-4 mm</p> <p>Refer to Page 13 for Tension Adjustment.</p>
 <p>1-needle, 3-thread (Narrower)</p>	 <p>Right</p>	 <p>Standard</p>	 <p>4-5 mm</p>	<p>1-4 mm</p> <p>Refer to Page 13 for Tension Adjustment.</p>
 <p>Narrow Hemming-Method A</p>	 <p>Right</p>	 <p>Rolled Hem</p>	 <p>1.5 mm (Actually 3.5 mm)</p>	<p>1-2 mm</p> <p>Refer to Page 15 for Tension Adjustment.</p>
 <p>Narrow Hemming-Method B</p>	 <p>Right</p>	 <p>Rolled Hem</p>	 <p>1.5 mm (Actually 3.5 mm)</p>	<p>1-2 mm</p> <p>Refer to Page 15 for Tension Adjustment.</p>
 <p>Two thread (Wider or Narrower)</p>	<p>Remove Upper Looper Thread and attach Subsidiary Looper.</p>  <p>Left (Wider) or Right (Narrower)</p>	 <p>Standard</p>	 <p>6.2-7.2 mm (Wider) (align 4-5 mm line) 4-5 mm (Narrower)</p>	<p>1-4 mm</p> <p>Refer to Page 17 for Tension Adjustment.</p>