

**SKY**<sup>®</sup>  
DEVICES

Tablet with 3G  
PLATINUM VIEW



User Manual / Manual de Instrucciones

## **Introduction**

### **Announcements**

#### **Preventive maintenance**

Please always keep the MID dry. To avoid the device short trouble, corrosion fault and electric short, please prevent the device, battery and charger from water and moisture, and don't operate the device or charger by wet hand.

To avoid failure of device, battery and charger, please prevent the device, battery, charger from violent shock or shake.

To avoid failure of device, battery and charger, please prevent the device, battery, charger of all over heating or too cold circumstance

Never shock, throw, prod the MID, or drop, extrude, bend the MID.

Never disassemble the device and accessories arbitrarily, otherwise the device and accessories are not in our company warranty scope.

#### **Safety Instruction**

Before the operation of the MID, please read this chapter and teach your kids about these information. For further details, please refer to the safety instructions and announcement.

Never use the MID when driving car, in order to ensure safe driving.

In the medical area, please abide by related rules and regulations. Please shut down the MID when it is near to the medical area.

To avoid the wireless signal to interrupt the plane-controlled signal, please shut down the MID or using airplane mode when you are boarding a flight,

To avoid electronic equipment failure, please shut down the MID in the vicinage of high-accuracy electronic equipments.

Please don't disassemble the MID and accessories. Only authorized agent has access to service the MID.

Please keep the MID far away from magnetic equipments, the radiation of MID may erase the data stored in the magnetic equipments.

Never use the MID in the vicinage of high temperature, inflammable gas ( gas station).

Protect the MID and accessories from kids reach scope, and avoid the kids to use the MID without parents' supervision.

Please comply with related rules and regulations, and respect others' privacy and legal rights while using the MID.

Please strictly adhere to related instructions in the manual when using USB cable to ensure the safety of the MID or PC.

Never use the MID in bathroom or other humid environment, and please protect the MID from liquid wash or wet.

## Read me first

Please read this manual before operating your tablet, and keep it for future reference.

The descriptions in this manual are based on the default settings.

Images and screenshots used in this manual may differ from the actual product.

Available features and additional services may vary by device, software or service provider.

Our company is not liable for performance issues caused by third-party applications.

## Assembling

### Charge the battery

Before using the device for the first time, you must charge the battery.

**Warning:** Use only original batteries and chargers. Unapproved chargers or cables can cause batteries to explode or damage your device.

### Install the SIM card

### Install the memory card

**Notice:** Our company uses approved industry standards for memory cards, but some brands may not be fully compatible with your device.

## Unit at a Glance

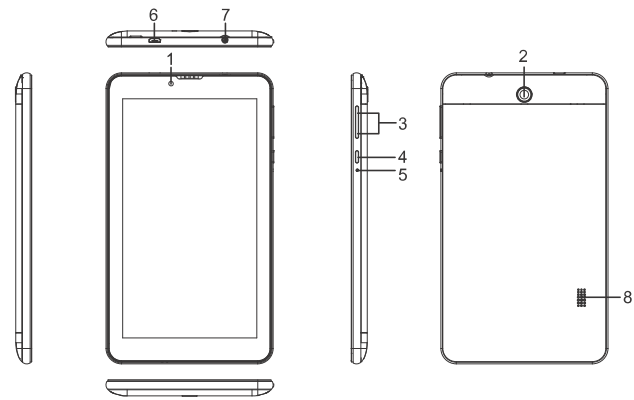

- 1.FRONT CAMERA
- 2.REAR CAMERA
- 3.VOL+/VOL-
- 4.POWER

- 5.RESET
- 6.TF CARD
- 7.EARPHONE
- 8.SPEAKER

EN-3

## Home screen

The home screen has multiple panels. Scroll left or right to the panels on the home screen, you can view indicator icons, widgets, shortcuts to applications, and other items.

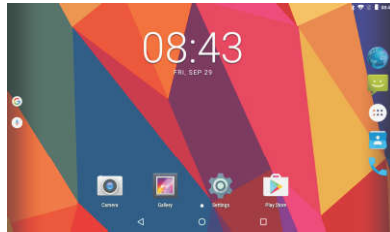

### **Task bar**

The task bar is shown at the bottom of the screen.

It displays commonly used option buttons, battery level indicator, current time and other indicator icons.

Return to previous screen.









Return to home screen.

View the applications you have accessed recently.









Open application menu.

Display notification icons. Tap the notifications area to open the notification panel.

## Indicator icons

Icon	Definition
	Open Wi-Fi available
	Wi-Fi connected
	Signal strength
	Roaming mode
	Uploading data
	Downloading data
	Connected to PC
	Alarm activated

## Indicator icons

Icon	Definition
	Flight mode activated
	New email
	New text or multimedia message
	Call in progress
	Missed call
	Call on hold
	Call diverting activated
	Battery power level
	Music being played

## Notification panel

Tap the notifications area to open the notification panel shown below. You can access a list of notifications. Tap icon to activate or deactivate wireless connection features and other settings.



**Wi-Fi:** Activate or deactivate the Wi-Fi connection.

**Auto-rotate screen:** Activate or deactivate the auto rotation feature.

**Brightness:** Adjust the basic brightness level of the display to lighter or darker.

**Notifications:** Activate or deactivate the notification feature.

**Settings:** Access Settings application.

## **Auto rotation**

If you rotate the device while using some features, the interface will automatically rotate as well. To prevent the interface from rotating, open the notifications panel and select Auto-rotate screen, then scroll it to Off.

## **Lock & unlock the screen**

To unlock the screen, tap and hold the lock icon, then drag it to the unlock area where the unlock icon is.

To lock the screen manually, press Power key.

## **Enter text**

You can enter text by selecting characters on the virtual keyboard.

Tap the text input field to display the virtual keyboard. To hide the keyboard, tap  at the task bar.

To change the text input method, tap  at the task bar.

From a text field, you can use the copy and paste feature for fast inputting.

## **Reset tablet**

You can reset system and desktop settings to their original values by the following steps:

1. Select SettingsBackup & reset from application list.
2. Tap Factory data reset.
3. If you want to erase **all** data on your tablet, such as music, pictures, and other data, tap Erase SD card checkbox to create a checkmark.
4. Tap Reset tablet.

The device resets to the factory default settings automatically.

**Warning!:** Factory data reset will erase all data from your device and SD card, including your google account, system and application data and settings, and downloaded applications.

## **Communication**

### **Phone**

To use calling functions, tap Phone from application list.

- **Make calls**

- **Answer a call**

To answer a call, drag the circled button to the green button.

- **Decline or end a call**

To decline a call, drag the circled button to the red button.

To end a call in progress, tap the red button.

- **Call settings**

To change call settings, tap the option button at the upper right.

#### **1. Ringtone & Vibrate**

- You can set different ringtones for incoming calls. Select Phone ringtone to open a list of ringtones, select the desired ringtone, and then select OK to confirm.

- Tap Vibrate when ringing to create a checkmark and the tablet vibrates to notify you of incoming calls.

### **Contacts**

Tap People from application list to access contacts.

- **Add new contact**

- **Edit a contact**

- **Create new group**

- **Rename group**

- **Import/Export contacts**

- **Search for contacts**

### **Messaging**

Create and send a text or multimedia message, and view or manage messages that you have sent or received.

### **Email**

To receive and send mail, you must have a remote mailbox service. This service may be offered by a service provider. Your device is compliant with applicable internet standards for POP3/IMAP/Exchange.

1. Before you can send or receive mail on your device, you need to set up an email account and define the email settings correctly.



## Web

### Browser

Tap Browser from application list to access to the web.

### Talk

Google Talk is a free web-based application for instant text, voice and video chats. Before using the Google Talk, you must have a Google Account.

## Entertainment

### Gallery

To view or organize your images and video clips, or edit and send your files to other devices, or set photos as wallpapers, select Gallery from application list.

**Note:** It takes a few more minutes to enter this application if you store more files.

### Supported file formats

Type	Format
Image	JPEG, GIF, BMP, PNG
Video	MPEG4-SP, H264/AVC, H263, VPX, 3GP, 3G2, MP4, MKV, AVI, WEBM

**Note:** Some files may not play properly depending on how they are encoded.

### Camera

With the camera function, you can capture photos and take videos.

## Tools

### Calendar

With the Calendar feature, you can consult the calendar by day, week, or month, create events, and set an alarm to act as a reminder, if necessary.

### Alarm

From application list, tap Clock, and then

select  to add alarm.

### **File Manager**

Many features of the device, such as images, videos, documents, received attachments and downloaded files or applications, use memory to store data. With File manager, you can store and browse files and folders in your device, or edit, move, copy files; you can send files to compatible devices as well.

### **Sound Recorder**

With Recorder, you can record a voice memo. From application list, tap Recorder.

### **Calculator**

## **Connectivity**

### **USB Connection**

You can connect your device to a PC and use it as a removable disk, which allows you access the file directory.

1.If you want to transfer files from or to a memory card, insert a memory card into the device.

2.With a USB cable, connect your device to a PC.

3.Open the notification panel, select USB connected.

4.Tap Turn on USB storage.

5.Open the folder to view files.

6.Copy files from the PC to the memory card.

### **Wi-Fi**

With Wi-Fi, you can connect to the internet or other network devices anywhere an access point or wireless hotspot is available.

#### **• Activate the Wi-Fi feature**

1.From application list, tap Settings.

2.In the field of WIRELESS & NETWORKS, turn on the Wi-Fi feature.

#### **• Find and connect to Wi-Fi**

1.Once the Wi-Fi feature is activated, the device automatically search for available Wi-Fi connection.

2.Select a network.

3.Enter a password for the network (if necessary).

4.Select Connect.

## **Safety Precautions**

Read these simple guidelines before using your device. Not following them may be dangerous or illegal.

### **Aircraft**

Switch off in aircraft and follow any restrictions. Wireless devices can cause interference in aircraft.

### **Vehicles**

Never use your device while driving. Place it in a safe place.

Position your device within easy reach. Be able to access your device without removing your eyes from the road.

### **Electronic devices**

In some circumstances your device may cause interference with other devices.

### **Potentially explosive environments**

Switch off your device when in any area with a potentially explosive atmosphere, and obey all signs and instructions. Sparks in such areas could cause an explosion or fire resulting in bodily injury or even death.

### **Pacemakers and other medical devices**

Pacemaker manufacturers recommend that a minimum separation of 8 inches be maintained between a wireless device and a pacemaker to avoid potential interference with the pacemaker.

Operation of any radio transmitting equipment, including wireless phones may interfere with the functionality of inadequately protected medical devices. Consult a physician or the manufacturer of the medical device to determine if they are adequately shielded from external RF energy or if you have any questions. Switch off your device in health care facilities when any regulations posted in these areas instruct you to do so.

### **Operating environment**

When connecting to other device, read its user guide for detailed safety instructions. Do not connect incompatible products. Do not place your device in the air bag deployment area.

Use the device only in its normal operating positions as explained in the product documentation.

Always switch off your device when its use is prohibited or when it may cause interference and danger.

**Areas with posted regulations**

Switch off your device when any regulations posted in these areas instruct you to do so.

## Care & Maintenance

- Use only manufacturer-approved accessories. Use general accessories may shorten the life of your device or cause device to malfunction.
- Keep your device dry. Humidity and all types of liquids may damage device parts or electronic circuits.
- Do not use or store the device in dusty, dirty areas.
- Do not store the device in hot or cold areas.
- Do not store your device near magnetic fields.
- Do not store your device with such metal objects as coins, keys and necklace.
- Do not drop your device or cause impacts to your device.

## Specifications

Processor	MTK 8321 , Quad Cortex-A7 1.3GHz
RAM	1GB DDR3
Storage	8GB flash built-in; micro SD card (max.32GB supported)
Display	7" TN LCD(1024x600)
Wi-Fi Networking	IEEE 802.11 b/g/n
Bluetooth	BT4.0
Audio Output	3.5mm headphone
PC Interface	USB 2.0 high speed
Additional Features	Built-in microphone Front facing camera(2.0MP), Rear 5.0MP 1X1W speaker
Operating System	Android™ 7.0
Power	Rechargeable Li-poly battery, power Adapter(DC 5V, 1.5A)
Playback Time (hours)	Up to 4 hours music, 2.5 hours video, 2.5 hours web browsing
2G Band	850/900/1800/1900 MHz
3G Band	850/1900/2100 MHz

Android is a trademark of Google LLC.  
Google, Android and Google Play are trademarks of Google LLC.  
Android and other marks are trademarks of Google LLC.  
The Android robot is reproduced or modified from work created and shared by Google and used according to terms described in the Creative Commons 3.0 Attribution License.

## FCC Statement

This equipment has been tested and found to comply with the limits for a Class B digital device, pursuant to part 15 of the FCC Rules. These limits are designed to provide reasonable protection against harmful interference in a residential installation. This equipment generates, uses and can radiate radio frequency energy and, if not installed and used in accordance with the instructions, may cause harmful interference to radio communications. However, there is no guarantee that interference will not occur in a particular installation. If this equipment does cause harmful interference to radio or television reception, which can be determined by turning the equipment off and on, the user is encouraged to try to correct the interference by one or more of the following measures:

- Reorient or relocate the receiving antenna.
- Increase the separation between the equipment and receiver.
- Connect the equipment into an outlet on a circuit different from that to which the receiver is connected.
- Consult the dealer or an experienced radio/TV technician for help.

Caution: Any changes or modifications to this device not explicitly approved by manufacturer could void your authority to operate this equipment.

This device complies with part 15 of the FCC Rules. Operation is subject to the following two conditions: (1) This device may not cause harmful interference, and (2) this device must accept any interference received, including interference that may cause undesired operation.

### Specific Absorption Rate (SAR) information:

This Tablet with 3G meets the government's requirements for exposure to radio waves. The guidelines are based on standards that were developed by independent scientific organizations through periodic and thorough evaluation of scientific studies. The standards include a substantial safety margin designed to assure the safety of all persons regardless of age or health. FCC RF Exposure Information and Statement the SAR limit of USA (FCC) is 1.6 W/kg averaged over one gram of tissue. Device types: Tablet with 3G has also been tested against this SAR limit. This device was tested for typical body-worn operations with the back of the tablet kept 0mm from the body. To maintain compliance with FCC RF exposure requirements, use accessories that maintain an 0 mm separation distance between the user's body and the back of the tablet. The use of belt clips, holsters and similar accessories should not contain metallic components in its assembly. The use of accessories that do not satisfy these requirements may not comply with FCC RF exposure requirements, and should be avoided.

**SKY**<sup>®</sup>  
DEVICES



Designed in the USA  
Manufactured to Sky Devices Specifications