

User's Information Manual

Bobcat Direct-Vent Sealed Combustion Condensing Boiler Model B-120A and B-200A

FOR YOUR SAFETY:

- Before operating this boiler, READ this manual.
- DO NOT attempt to install, service or repair this boiler yourself. There are no user serviceable parts. Contact a qualified service agency if your boiler needs repair or maintenance. Ask your gas supplier for a list of qualified service agencies.
- A qualified service agency should inspect the venting system of this boiler on an annual basis.



WARNING: If the information in this manual is not followed exactly, a fire or explosion may result causing property damage, personal injury or loss of life.

— **DO NOT** store or use gasoline or other flammable vapors and liquids in the vicinity of this or any other appliance.

— **WHAT TO DO IF YOU SMELL GAS**

- **DO NOT** try to light any appliance.
- **DO NOT** touch any electrical switch
- **DO NOT** use any phone in your building.
- Immediately call your gas supplier from a neighbor's phone. Follow the gas supplier's instructions.
- If you cannot reach your gas supplier, call the fire department.

— Installation and service must be performed by a qualified installer, service agency or the gas supplier.

Your gas boiler must be installed and serviced by a qualified service agency or gas supplier. The lack of proper service can result in a dangerous condition.

This manual must be left with owner, hung on or adjacent to the boiler. Owner should retain manual for future reference.

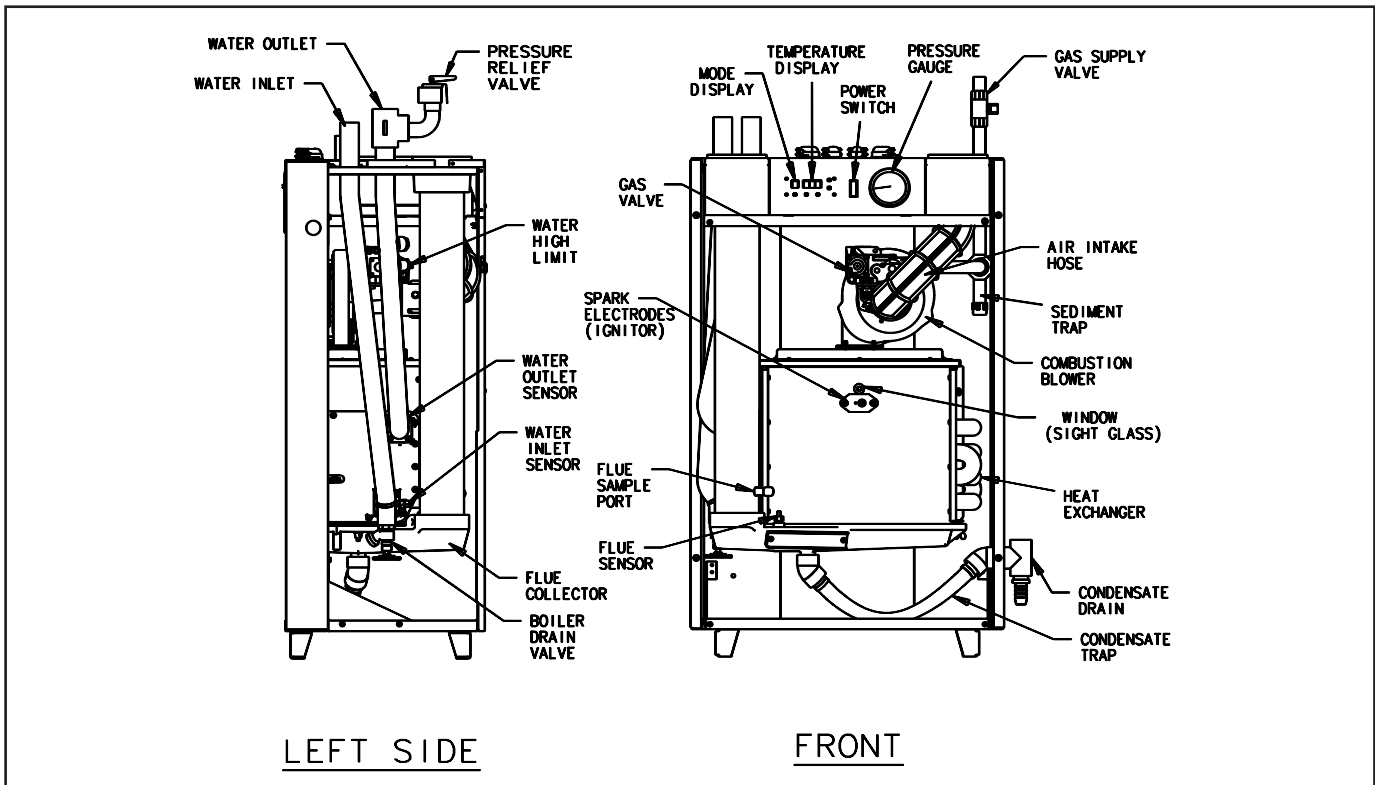

Figure 1. Location and identification of parts. (model 120A shown)

WELCOME TO OUR VALUED CUSTOMER

You are now the owner of a Slant/Fin Bobcat series gas-fired boiler, another quality heating product designed and manufactured by an industry leader, to provide your family with many years of reliable comfort and trouble-free performance.

The care and maintenance of your new boiler is important to prevent a hazardous condition which might result from lack of proper servicing. Therefore, you should perform regular “owner” inspections as described in this manual (and report any concerns to a qualified service technician) as well as have your boiler serviced by a qualified service technician at least once a year, preferably before the beginning of each heating season.

LIGHTING INSTRUCTIONS

Locate, read and then follow the procedures on the lighting instructions label attached to the boiler. For reference, we have reproduced those instructions in this manual.

DO NOT use this boiler if any part has been underwater. Immediately call a qualified service technician to inspect the boiler and to replace any part of the control system and any gas control which has been underwater.

WARNING

Should overheating occur or the gas supply fail to shut off, **DO NOT** turn off or disconnect the electric supply to the circulator pump. Instead, shut off the gas supply at a location **EXTERNAL** to the appliance.

WARNING

SLANT/FIN DOES NOT PERMIT THE USE OF VENT DAMPERS ON BOBCAT B-120 or B-200 SERIES BOILERS. OTHER DAMPERS OR DEVICES WITH SIMILAR PURPOSE ARE NOT PERMITTED.

Keep the boiler area clean and free of all materials that can burn.
NEVER close or reduce openings that supply air for the boiler fire and for ventilation.

INSPECTION

Your boiler and heating system will last an indefinitely long time at full efficiency, if it is inspected regularly and is kept in good repair and adjustment. You, the user, should make regular inspections, and report any problems to your service agency. At regular intervals, you should have that agency inspect the system and make repair adjustments as necessary. What you and the service agency should do is listed below. Contact your gas supplier for a list of qualified service and repair agencies.

USER INSPECTION

The user should make the following inspections at least once each month during the heating season and once just before cold weather starts. Bobcat B-120 and B-200 boilers may be installed and vented either as direct-vent boiler, which all air for combustion is obtained directly from outside through the air intake piping or as non-direct-vent boiler, which all air for combustion is taken from inside the boiler room. Typical direct-vent installations are shown on Figures 2 and 3. Non-direct-vent installation is shown on Figures 4, 5 and 6.

1. VENTING AND AIR INTAKE SYSTEM REGULAR INSPECTION

Inspect the system regularly for condensation, corrosion, sagging and/or physical damage. A qualified professional should service the boiler annually and include such an inspection at that time. The homeowner should look over the system monthly for damage, water stains, any signs of rust, other corrosions or separation of the vent and air intake piping (if direct-vent).

Should an inspection turn up signs of condensation, corrosion, sagging or damage, the boiler should be shut down immediately and the condition should be corrected by a qualified professional.

If the boiler is vented horizontally through the wall, the outside termination, louvers and screen should be checked for any debris blocking the opening and cleaned as required.

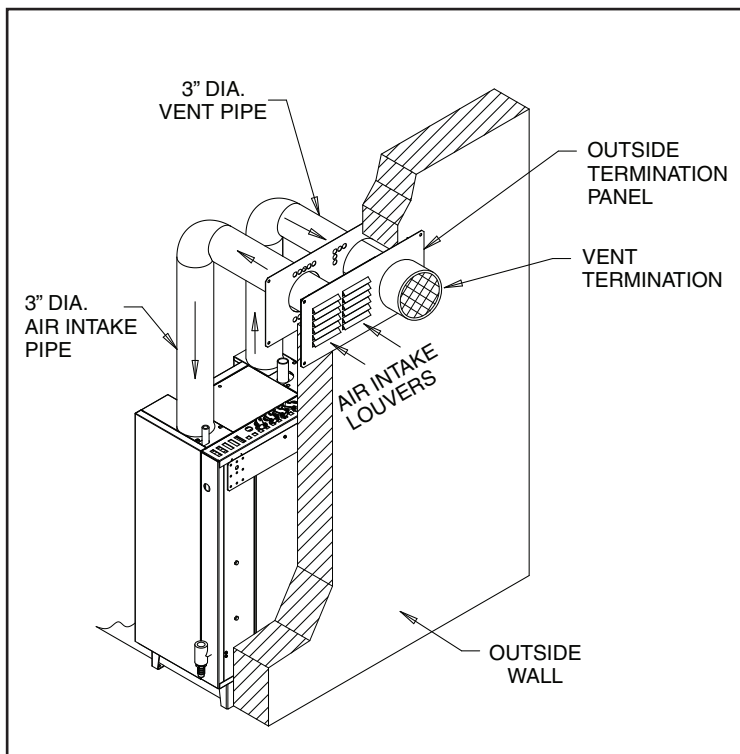

Figure 2. Direct vent, sidewall venting illustration.

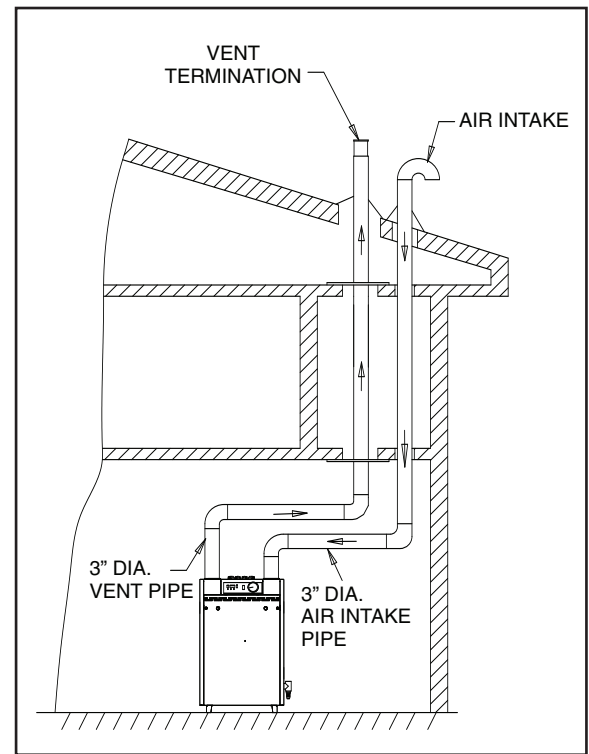

Figure 3. Direct vent, venting and air intake through a roof.

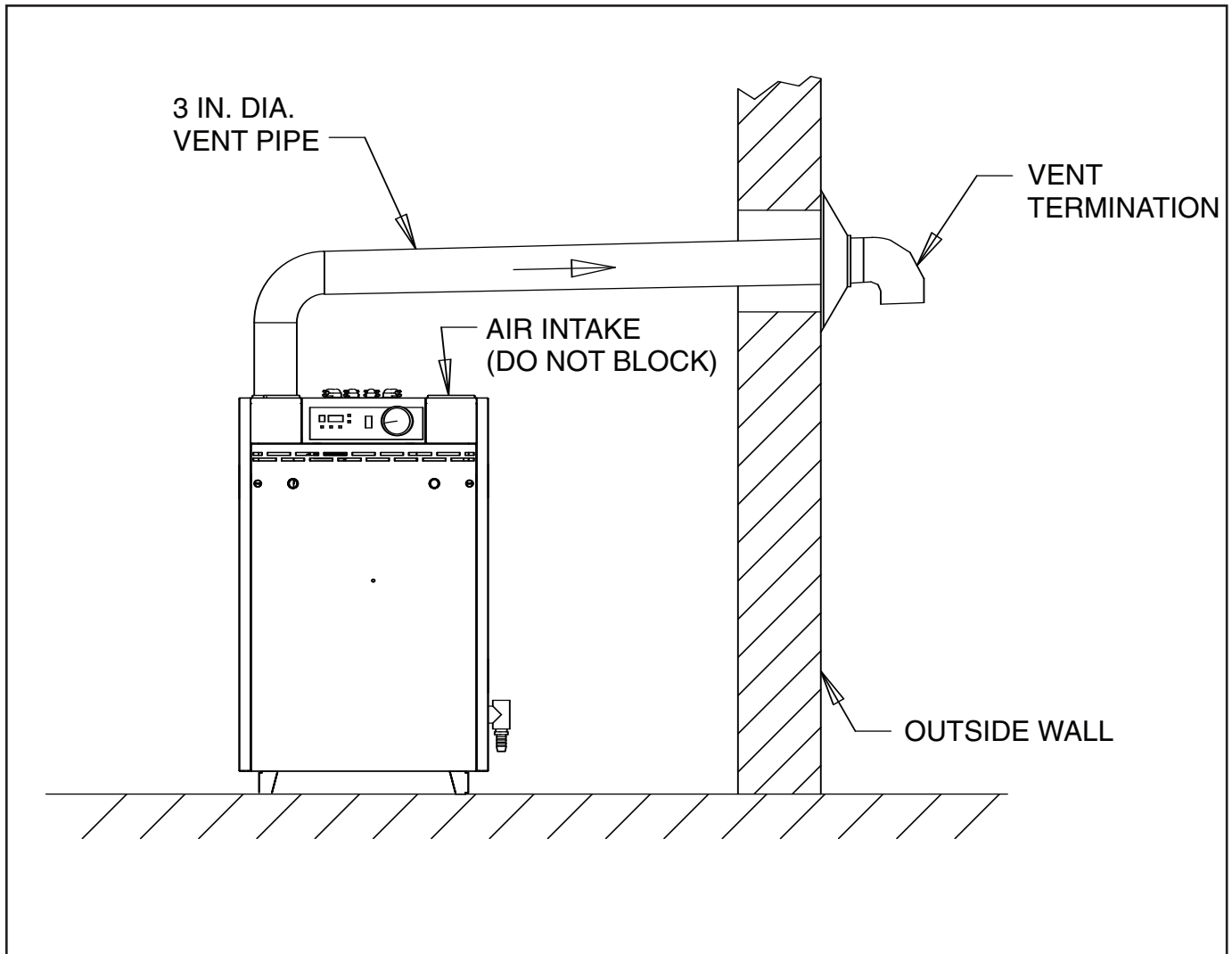

Figure 4. Non-direct vent, sidewall venting.

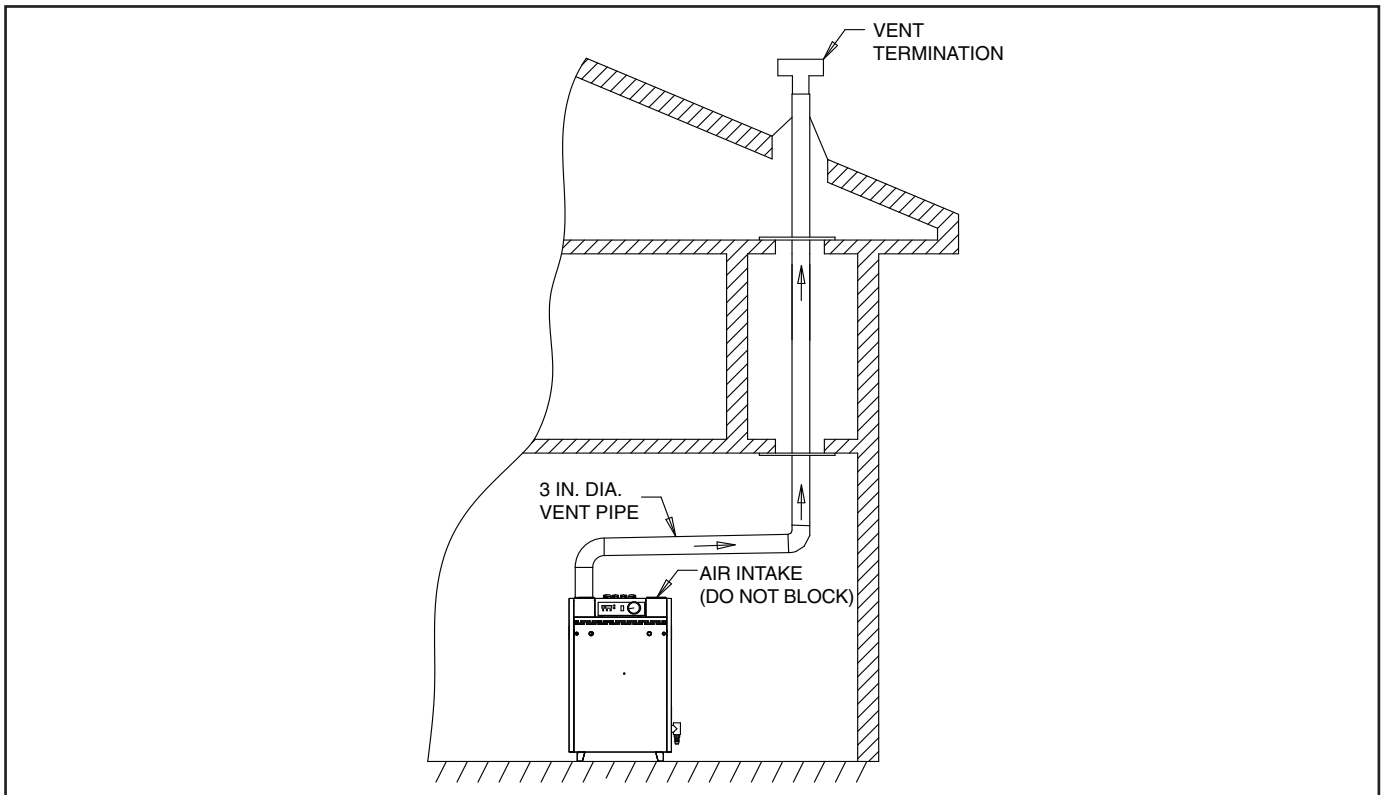

Figure 5. Non-direct vent, venting through the roof.

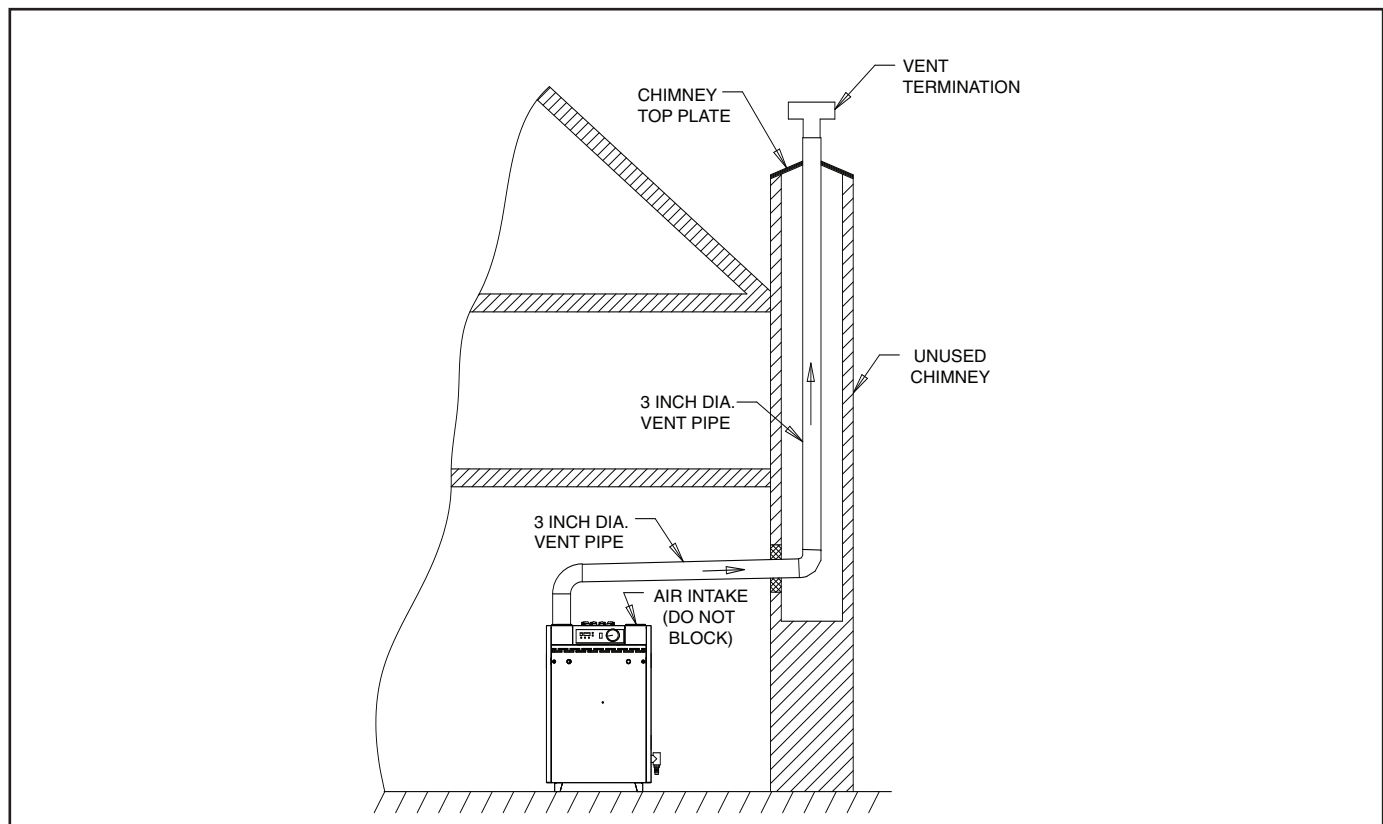

Figure 6. Non-direct vent, utilizing an existing chimney as a chase.

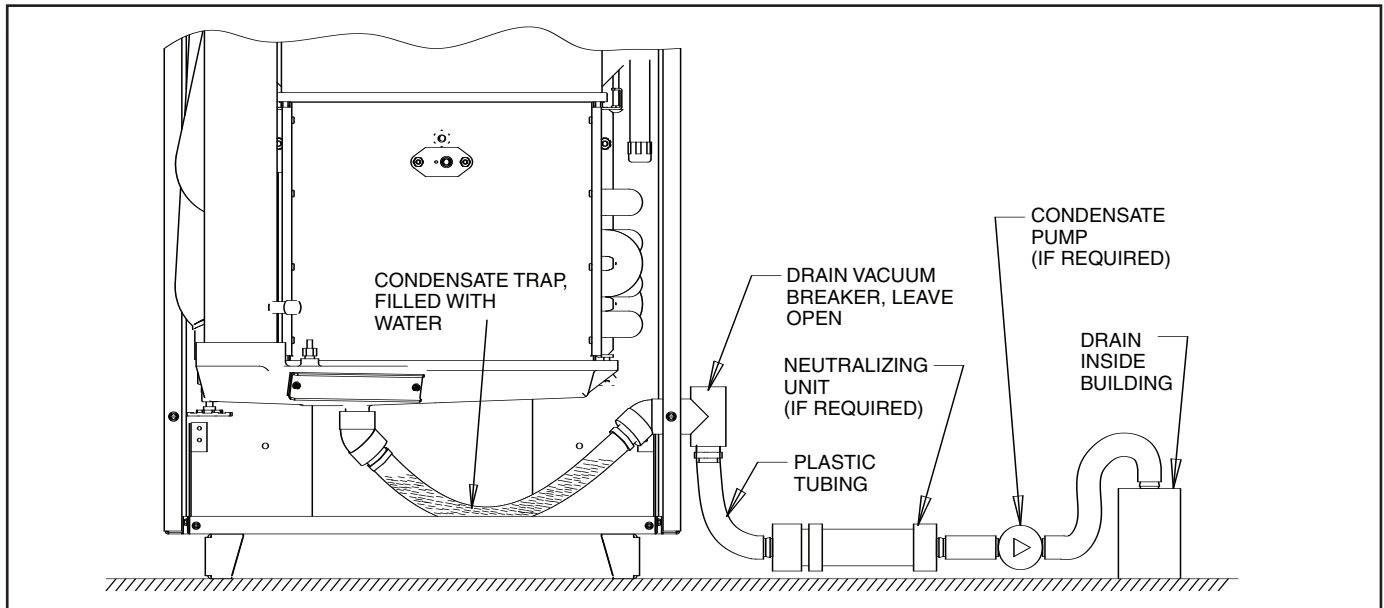

Figure 7. Condensate disposal system

2. CONDENSATE REMOVAL SYSTEM

The Bobcat B-120 and B-200 boilers are equipped with a built-in condensation drain and trap. The trap must be filled with water. DO NOT operate the boiler without filling the trap with water to prevent flue gas discharge into space. Periodic inspection should be made of this assembly for deterioration of the tubing and to insure that the trap is not plugged. If it is plugged or appears to have excessive sediment in it, it should be removed from the drain assembly, straightened out to clear the obstruction, reformed, filled with water and reinstalled as before. (See Figure 7).

Leave the top of the condensate drain tee open, to act as a vacuum breaker. Do not allow any part of the condensate removal system to be exposed to freezing temperatures, or any other conditions that could cause blockage.

If a neutralizing system is installed, the filter medium will require periodic changing, to ensure it's effectiveness. Refer to the neutralizing unit's manufacturers instructions, if available, or change the medium on an annual basis.

3. PIPING INSPECTION

Look at all water piping. There should be no leaks or signs of leaks at any pipe joints or around the boiler.

4. SYSTEM WATER PRESSURE INSPECTION

The boiler water pressure is indicated on the pressure gage (See Figure 1 for location). The boiler water outlet temperature is normally indicated on the temperature display (See Figure 1 for location and Figure 9 for digits illustration). For most installations, it should indicate

about 12 to 15 psi pressure when temperature is about 70 to 100°F and from 15 psi to 25 psi when temperature is up to 195°F. FOR YOUR SYSTEM, there is one correct pressure for each temperature. ASK YOUR INSTALLER OR SERVICEPERSON TO EXPLAIN AND SHOW YOU. Learn what normal pressure to look for. If pressure increases from normal, the relief valve will open to relieve the pressure. Call your service organization if pressures are higher or lower than normal, and if the relief valve spills water. Repair or adjustment is needed.

5. UNUSUAL NOISE

Stand near the boiler and look and listen. As the burner start and shut off, there should be no unusual noise.

6. BOILER ROOM AIR SUPPLY

Ample boiler room fresh air is required for combustion (non-direct vent installation) and ventilation (direct-vent installation).

Check air vents for continues positive supply of air as required. Air needs are greatest in cold weather if boiler installation is non-direct vent method. Air vents must be open and free of obstruction.

Warning: The flow of combustion and ventilating air to the boiler should not be obstructed.

Warning: If you find any problem during your inspection, call for service immediately.

The combustion air supply must not be susceptible to contaminants, which may cause corrosion or other damage to the heat exchanger and components of the boiler, causing failure of these parts or unsafe operation.

Below is a list of products which must be avoided from being stored or entering the boiler room or air supply area:

PRODUCTS TO AVOID

- Spray cans containing chloro/fluorocarbons
- Permanent wave solutions
- Chlorinated waxes/cleaners
- Chlorine-based swimming pool chemicals
- Calcium chloride used for thawing
- Sodium chloride used for water softening
- Refrigerant leaks
- Paint or varnish removers
- Hydrochloric acid/muriatic acid
- Cements and glues
- Antistatic fabric softeners used in clothes dryers
- Chlorine-type bleaches, detergents and cleaning solvents found in household laundry rooms.
- Adhesives used to fasten building products and other similar products.

ANNUAL SERVICE AND GENERAL MAINTENANCE

A trained and qualified service technician should perform inspection and general maintenance listed in Installation and Operating Instructions (Publication No. B-40) before each heating season and at regular intervals.

WARNING: If you do not follow these instructions exactly, a fire or explosion may result causing property damage, personal injury or loss of life.

SAFETY AND OPERATING INSTRUCTIONS

Follow the lighting instructions in this manual. These instructions are also attached to the boiler.

SAFETY INFORMATION

For Your Safety Read Before Operating

- A. This appliance does not have a pilot. It is equipped with an ignition device which automatically lights the burner. Do not try to light the burner by hand.
- B. BEFORE OPERATING smell all around the appliance area for gas. Be sure to smell next to the floor because some gas is heavier than air and will settle on the floor.

WHAT TO DO IF YOU SMELL GAS:

- Do **not** try to light any appliance.
- Do **not** touch any electric switch: do **not** use any phone in your building.
- Immediately call your gas supplier from a neighbor's phone. Follow the gas supplier's instructions.
- If you cannot reach your gas supplier, call the fire department.

- C. Use only your hand to turn the gas supply shut off valve. Never use tools. If the supply shut off will not turn by hand, don't try to repair it, call a qualified service technician. Force or attempted repair may result in a fire or explosion.
- D. **DO NOT** use this appliance if any part has been under water. Immediately call a qualified service technician to inspect the appliance and to replace any part of the control system and any gas control which has been under water.

OPERATING INSTRUCTIONS

1. STOP! Read the safety information above.
 2. Set the thermostat to lowest setting.
 3. Turn off all electric power to the appliance.
 4. This appliance is equipped with an ignition device which automatically lights the burner. **Do not** try to light the burner by hand.
 5. Open the gas supply shut off valve, by turning the handle to be parallel to the gas piping. (See Figure 8).
 6. Wait five (5) minutes (longer for propane) to clear out any gas, then smell for gas, including near the floor. If you then smell gas, STOP! Follow "B" in the safety information above on this page. If you don't smell gas, go to next step.
 7. Turn on all electric power to the appliance.
 8. Set thermostat to desired setting.
- If the appliance will not operate, follow the instructions "To Turn Off Gas to Appliance" and call your service technician or gas supplier.

To Turn Off Gas to Appliance

1. Set thermostat to lowest setting.
2. Turn off all electric power to the appliance if service is to be performed.
3. Close the gas supply shut off valve, by turning the handle to be perpendicular to the gas piping. (See Figure 8).

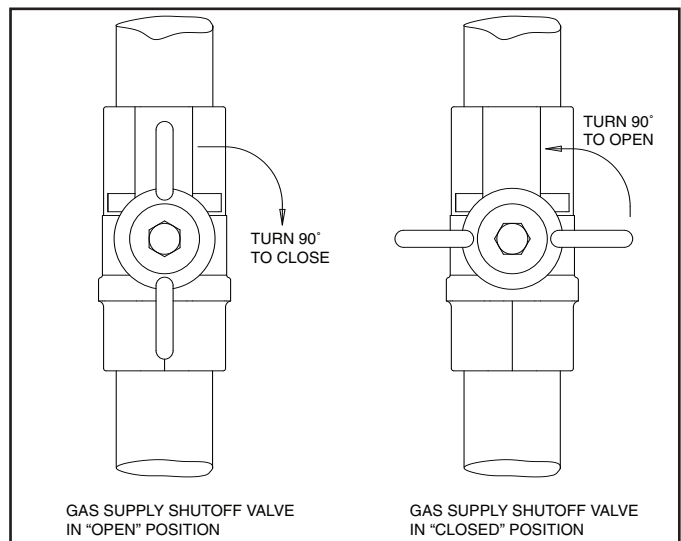

Figure 8.

Removing Jacket Front Panel

1. Turn black screws ¼ turn to open position.
2. Remove front panel.
To replace the panel, reverse procedure.

INTEGRATED BOILER CONTROL

The integrated boiler control monitors the status of the room thermostat, high limit switch, low water cutoff (if installed), water inlet and outlet sensors, flue gas sensor and flame sensor. It controls the operation of the circulator, combustion blower, gas valve and spark ignitor. The boiler control also determines the sequence of operation and timing for pre and post purge periods, trial for ignition and lock out.

The control display board provides information on boiler operation on a mode and temperature display and can be viewed, programmed and reset with specific push buttons. Diagnostic information is also provided on the display, to help determine the cause of boiler failure. (See Figure 9).

BOILER CONTROL AND DISPLAY FEATURES

(See Figure 9)

A. BOILER OPERATION STATUS: “Mode Display” shows status of boiler operation. (See Table 1).

B. VIEW AND CHANGING TEMPERATURES: Setting boiler supply water temperature and water tank temperatures (See Table 2).

Press “Select” button for viewing following different modes on “Mode Display”

1. While “c” is blinking, boiler supply water temperature for space heating may be set to desired temperature. The setting range is between 90° to 185°F.
2. While “d” is blinking, boiler supply water temperature for DHW may be set to desired temperature. The setting range is between 104° to 185°F.

3. While “t” is blinking, DHW tank temperature may be set to desired temperature (if tank is equipped with sensor). The setting range is between 104° to 185°F.
4. View actual following temperatures on “Temperature Display”, Press “Select” button for selection:
 - a. Supply water temperature – Select #1 on “Mode Display”.
 - b. Return water temperature – Select #2 on “Mode Display”.
 - c. Domestic hot water tank temperature (if tank equipped with sensor) – Select #3 on “Mode Display”.
 - d. Flue gas temperature – Select #4 on “Mode Display”.
 - e. Outside temperature (if outside sensor is used) – Select #5 on “Mode Display”.

C. Display Board Pushbuttons:

1. **Reset** - Used to clear a Lockout Error (indicated with an “A” in the “Mode Display”)
2. **Select** - Used to scroll through the modes in the “View and Changing Temperatures” and “Viewing and Changing System Setting” menus.
3. **Enter** - Used to store values that are changed in the “View and Changing Temperatures” and “Viewing and Changing System Setting” menus.
4. **Up** - Used to increase values in the “View and Changing Temperatures” and “Viewing and Changing System Setting” menus.
5. **Down** - Used to decrease values in the “View and Changing Temperatures” and “Viewing and Changing System Setting” menus.

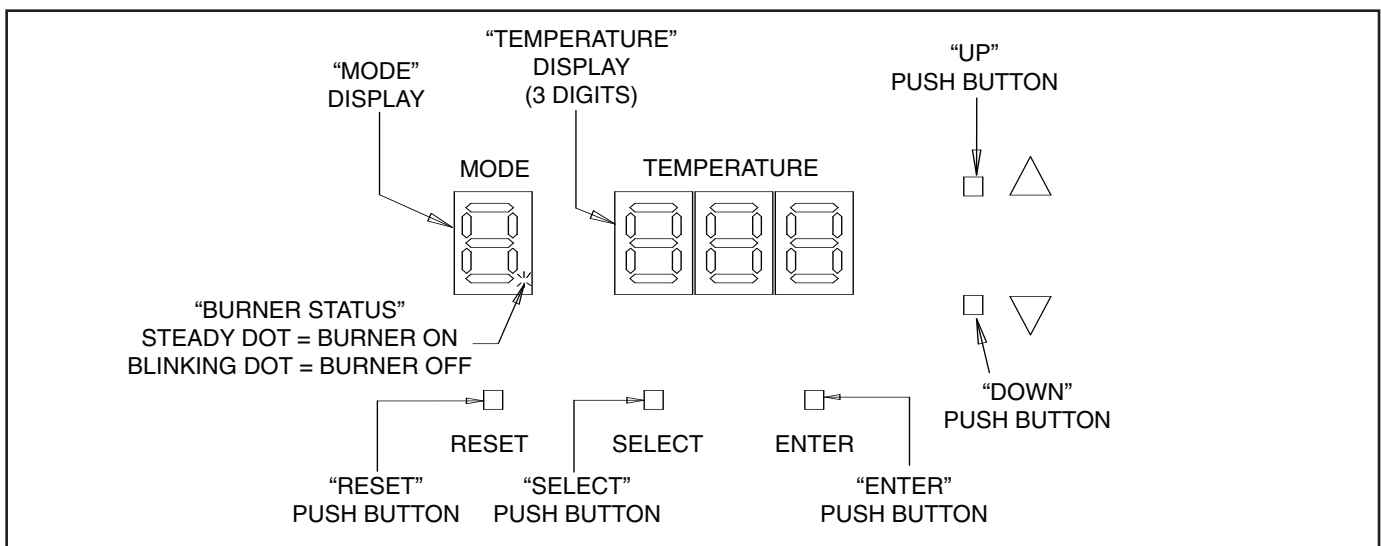

Figure 9. Display Board

Bobcat Boiler Display Board “Boiler Operation Status”

Mode Display	Description & Temperature Display
0	Boiler is on stand-by mode. Temperature display shows supply water Temp.
C	Space heating mode. Temperature display shows supply water Temp.
D	Domestic hot water mode. Temperature display shows supply waterTemp.
F	Frost protection mode.** Temperature display shows supply water Temp.
R	Lockout (Alarm) condition. Temperature Display indicates the lockout code Reset button must be pressed to resume normal operation.
E	Error Condition. * Temperature display indicates the error code.
H	Warning Condition. *** Temperature display indicates the error code.

Table 1

Note:

Blinking dot on “Mode Display” indicates active heating control, burner off. Steady dot indicates burner is on.

*: Error must be corrected to resume boiler operation. Pressing the “Reset” button is not required.

** : The boiler circulator is energized, when boiler water temperature drops below 50°F.

***: Error must be corrected to resume DHW operation. Space heating not affected. Pressing the “Reset” button is not required.

Table 2: Viewing and Changing Temperatures

Press “Select” button for viewing different modes on “Mode Display”



Mode Display	Description & Temperature Display
 Blinking	Space heating supply water temperature could be changed by pressing “Up/Down” button. Settable from 90°F to 185°F (steps of 1 F). The default valve is 176° F Press “Enter” button to store. (see note 1)
 Blinking	Domestic hot water supply temperature could be changed by pressing “Up/Down” button. Settable from 104°F to 185°F (steps of 1 F). The default valve is 176° F Press “Enter” button to store. (see note 2)
 Blinking	Domestic hot water tank temperature could be changed by pressing “Up/Down” button. Settable from 104°F to 160°F (steps of 1 F). The default valve is 140° F. Press “Enter” button to store. (see note 3)
1	Temperature display shows actual supply water temperature.
2	Temperature display shows actual return water temperature.
3	Temperature display shows actual DHW tank temperature. (if the water tank is equipped with sensor)
4	Temperature display shows actual flue gas temperature.
5	Temperature display shows actual outside temperature. (boilers with outdoor sensor)

Table 2

Notes:

1. For space heating mode “0” (boilers not utilizing outdoor sensor)
2. For DHW mode “2” (storage tank with Aquastat)
3. For DHW mode “1” (storage tank with sensor)

DIAGNOSTIC ERROR CODES

WARNING:

If an operational problem has occurred, the boiler will shut off and show an “A”, “E” or “H” in the mode display, along with an error code in the temperature display.

Do not attempt performing any service under these conditions, but do note the mode and temperature display indication, in case the problem clears itself. An “A” indication error can be cleared by pressing the reset button once, which will allow re-try of operation. Do not repeatedly press the reset button in this case, or if an “E” or “H” indication error is displayed. Call a trained, experienced service technician to troubleshoot and correct the problem. The Bobcat Installation and Operating Instructions, publication B-40 contain a full troubleshooting section for this. Turn off all electric power of the boiler before service.

A. LOCKOUT ERRORS:

Indicated by an “A” in the mode display. The reset button must be pressed to clear the error and retry operation. The temperature display shows the error code.

ERROR CODE	INDICATION
01	Ignition Failure - 3 unsuccessful ignition attempts in a row
02	Flame Failure - 3 losses of flame signal during one demand
03	Water High Limit Open
04, 05, 09, 10, 12, 13, 14, 15, 16, 18, 32	Control Failure
19, 20	Flame Detected at Wrong Time
33	Fan Failure - RPM Error

B. BLOCKING ERRORS:

Indicated by an “E” in the mode display. Operation is automatically restored, once the condition returns to normal or is fixed. The temperature display shows the error code. Pressing the “Reset” button is not required.

ERROR CODE	INDICATION
01	Water Outlet Sensor Open
02	Water Inlet Sensor Open
03	Flue Gas Sensor Open
11	Water Outlet Sensor Shorted
12	Water Inlet Sensor Shorted
13	Flue Gas Sensor Shorted
19, 42, 45, 46, 47, 48	Control Failure
20	Flame Detected at Wrong Time
21	Polarity Error
22	Frequency Error
24	Earth Connection Faulty
30	Excess Flue Temperature
31	Low Water Cutoff Error
32	Excess Water Inlet Temperature
51	Reset Button Error
52	Boiler Model Selection Error

C. WARNING ERRORS:

Indicated by an “H” in the mode display. Operation of the space heating mode is not affected, and the warning is displayed intermittently. Operation of the DHW mode is automatically restored, once the condition is fixed. The temperature display shows the error code. Pressing the “Reset” button is not required.

ERROR CODE	INDICATION
04	Domestic Hot Water Tank Sensor Open
14	Domestic Hot Water Tank Sensor Shorted

