

Low Frequency Mullion Mount Reader Installation Manual

FCC STATEMENT

1. This device complies with Part 15 of the FCC Rules. Operation is subject to the following two conditions:

- (1) This device may not cause harmful interference.
- (2) This device must accept any interference received, including interference that may cause undesired operation.

2. Changes or modifications not expressly approved by the party responsible for compliance could void the user's authority to operate the equipment.

NOTE: This equipment has been tested and found to comply with the limits for a Class B digital device, pursuant to Part 15 of the FCC Rules. These limits are designed to provide reasonable protection against harmful interference in a residential installation.

This equipment generates uses and can radiate radio frequency energy and, if not installed and used in accordance with the instructions, may cause harmful interference to radio

communications. However, there is no guarantee that interference will not occur in a particular installation. If this equipment does cause harmful interference to radio or television reception, which can be determined by turning the equipment off and on, the user is encouraged to try to correct the interference by one or more of the following measures:

- Reorient or relocate the receiving antenna.

- Increase the separation between the equipment and receiver.

- Connect the equipment into an outlet on a circuit different from that to which the receiver is connected.

- Consult the dealer or an experienced radio/TV technician for help.

Operation is subject to the following two conditions:

- (1) this device may not cause interference, and
- (2) this device must accept any interference, including interference that may cause undesired operation of the device.

Low Frequency Mullion Mount Reader Installation Manual

Mounting:

1. Install the back plate on the wall as shown in the diagram below ①.
2. The cover shall clip on the upper edge ② the push in the bottom part as show in diagram ③.
3. Tighten the non-dropout screw, which located underneath of the reader to fix the reader and the back plate ④, installation is completed.

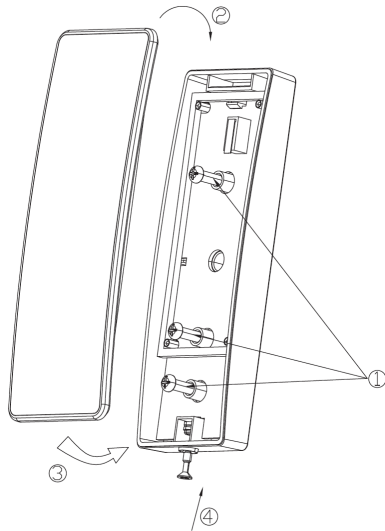

Specification:

Input Voltage (at Reader end)	DC9V~15V	Typical Read range	> 5cm
Operating Current	120mA (max)	Maximum Cable Length	150m
Operating Temperature	-30°C~70 °C		

Recommendation:

1. Linear DC Power Supply;
2. 22AWG shielded cable; it's required to do "one-point" ground. (As shown in the diagram)

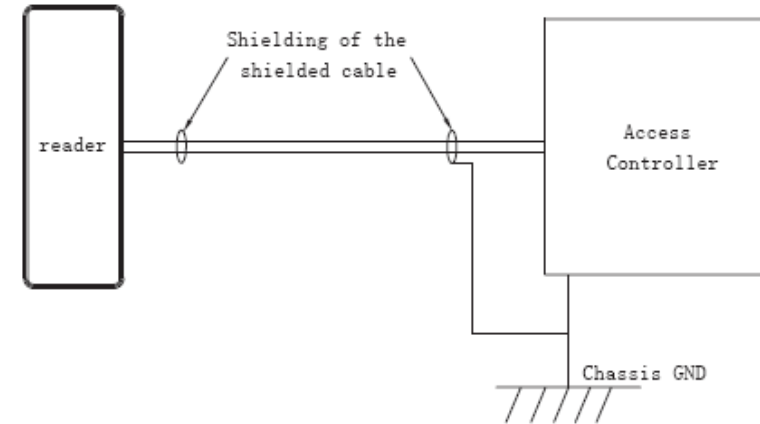

Wiring:

Color	Label	Description
Red	+12V dc	Power Supply to the reader
Black	GND	Signal GND
Green	RS232+/RS485+	RS232+/RS485+
White	RS232-/RS485-	RS232-/RS485-
Yellow	RED LED	RED LED control, active low.
Blue	Green LED	Green LED control, active low
Brown	Buzzer	Buzzer input, active low
Grey	Tamper	Tamper output (open collector, Active low, max 100mA)

Low Frequency Mullion Mount Reader Installation Manual

Power up Sequences:

1. When reader is powered up, the reader will flash in Green for 5 seconds . Then the Reader is ready.
2. Blue back lit stays on when the reader is ready.
3. When card is present and read by the reader, blue back lit will flash once; and buzzer will beep once as well. The card data will then transmit to the controller. After, weather the back lit of the reader will remain ON or Flash or change to Green or Red color, this shall depend on the Green and Red LED inputs.

Physical Dimension:

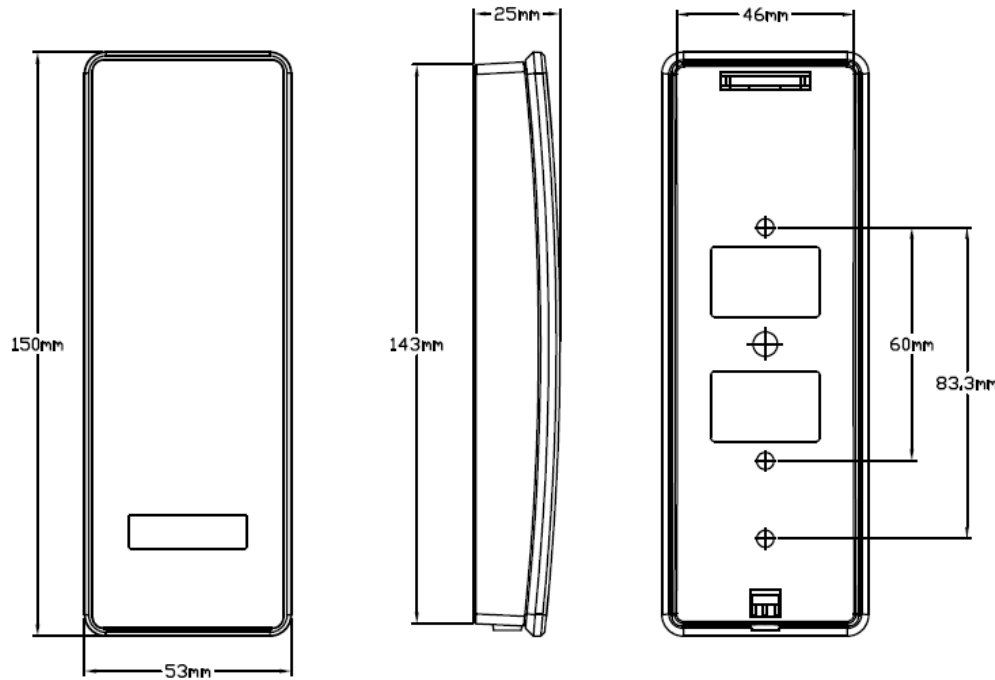

Troubleshooting:

Trouble List	Solution
No Response when Power Up	<ul style="list-style-type: none"> ● Discount the power and confirm that the power supply cable is correctly connected (See "Wiring" above). ● Check the input voltage is sufficient (See "Specifications" above).
Auto Restart	<ul style="list-style-type: none"> ● Check the input voltage is sufficient (See "Specifications" above).
Cannot read card number correctly	<ul style="list-style-type: none"> ● Check the format setting on the controller if it is the same as the card format. Use approved card (known format and Facility Code) to test. ● Check if the shield cable is correctly connected to Classis Ground at ONE point only.
Reader beeps but No card data info	<ul style="list-style-type: none"> ● Check if data 0 & data 1 cable is correctly connected (See "Wiring" above). ● Check the input voltage at the card reader end is correct (See "Specifications" above).
Buzzer error	<ul style="list-style-type: none"> ● Check if the buzzer cable is correctly connected (See "Wiring" above).
Back Lit Error	<ul style="list-style-type: none"> ● Check the Led cable is correctly connected (See "Wiring" above). ● Use Default Configuration Card to set it back to normal.