



Contactless Door Egress Device (North America Version)

Design Philosophy

- Match OEM reader design in order to maximize the marketing value at the door.

Technology & Function

- Capacitance Proximity Technology has been used instead of Infar-red technology – environmental independent design.
- Back Light design.
- Built-in buzzer
- When triggered, the back lit will change color with an audible tone – very user friendly.
- Provide a dry contact output to interface with any Access Control controller.
- Build-in Mechanical Override in case of power failure or electronic failure.
- Build-in a digital timer to control the relay output timing from 1 to 63 sec..
- Optional with Remote Control (433MHz) to trigger the REX output remotely.
- Each Remote Control can “learn” up to 5 Remote Buttons.

Friendly Installation



All inputs are 12Vdc protected.



All input and output signals are protected against static charges.



Reverse power protection.



Fit with US single gang box

Specification:

Model	REX2140-c	
Functions		
Functional Specification		
Request to Exit indication	Color changes from Blue to Green with a beep	
Request to Exit output	Dry contact output	
REX Relay	NC/NO jumper selectable rated @ 30Vdc; 1A	
Mechanical Override	Available	
Output Timer	From 1 sec to 63 sec	
Remote Button (Optional)	433MHz (Max supports 5 remote buttons at the same time.) 	
Dimension	118.2 (L) X 74.2 (W) X 8.5 (H) mm (above surface)	
Technical Specifications		
Typical Read range	~2.5 cm	
Electric Gang Box Requirement	Shall fit with most of the North America single gang box installation	
Weight	157g	

Operating Specification:

Operating Voltage	10 - 15VDC	Case material	PC+ABS
Operating Current	150mA (max @ 12Vdc)	Standard Color	Black & White
Operating Temperature	0°C-60°C	Operating Humidity	10% - 90%

FCC Caution.

§ 15.19 Labelling requirements.

This device complies with part 15 of the FCC Rules. Operation is subject to the following two conditions: (1) This device may not cause harmful interference, and (2) this device must accept any interference received, including interference that may cause undesired operation.

§ 15.21 Information to user.

Any Changes or modifications not expressly approved by the party responsible for compliance could void the user's authority to operate the equipment.

§ 15.105 Information to the user.

Note: This equipment has been tested and found to comply with the limits for a Class B digital device, pursuant to part 15 of the FCC Rules. These limits are designed to provide reasonable protection against harmful interference in a residential installation. This equipment generates uses and can radiate radio frequency energy and, if not installed and used in accordance with the instructions, may cause harmful interference to radio communications. However, there is no guarantee that interference will not occur in a particular installation. If this equipment does cause harmful interference to radio or television reception, which can be determined by turning the equipment off and on, the user is encouraged to try to correct the interference by one or more of the following measures:

- Reorient or relocate the receiving antenna.
- Increase the separation between the equipment and receiver.
- Connect the equipment into an outlet on a circuit different from that to which the receiver is connected.
- Consult the dealer or an experienced radio/TV technician for help.

REX2-c Installation and Operation Manual

REX2 (US Gang Box version) is a contactless proximity exit button. It is using capacitive proximity technology instead of Infra-Red to realize the contactless triggering. While Infra-Red technology exit button will trigger by sunlight, air conditioner or even a paper...etc, capacitive proximity technology does not have such problems. This makes REX2 a very ideal product for applications which requires a high hygiene requirement standard.

Function:

- Put your hand near the exit button then you will trigger the device. The color of the exit button will change to green when triggered. At the same time, the relay inside the exit button device will trigger for 1 second, and the buzzer will beep once.
- To adjust the door open duration, please power off the exit button. Change the DIP Switch setting to alter the door open duration from 1 to 63 seconds, and then power it up again.
- Support manually door open
- Support remote controlled door open

PCB setting description:

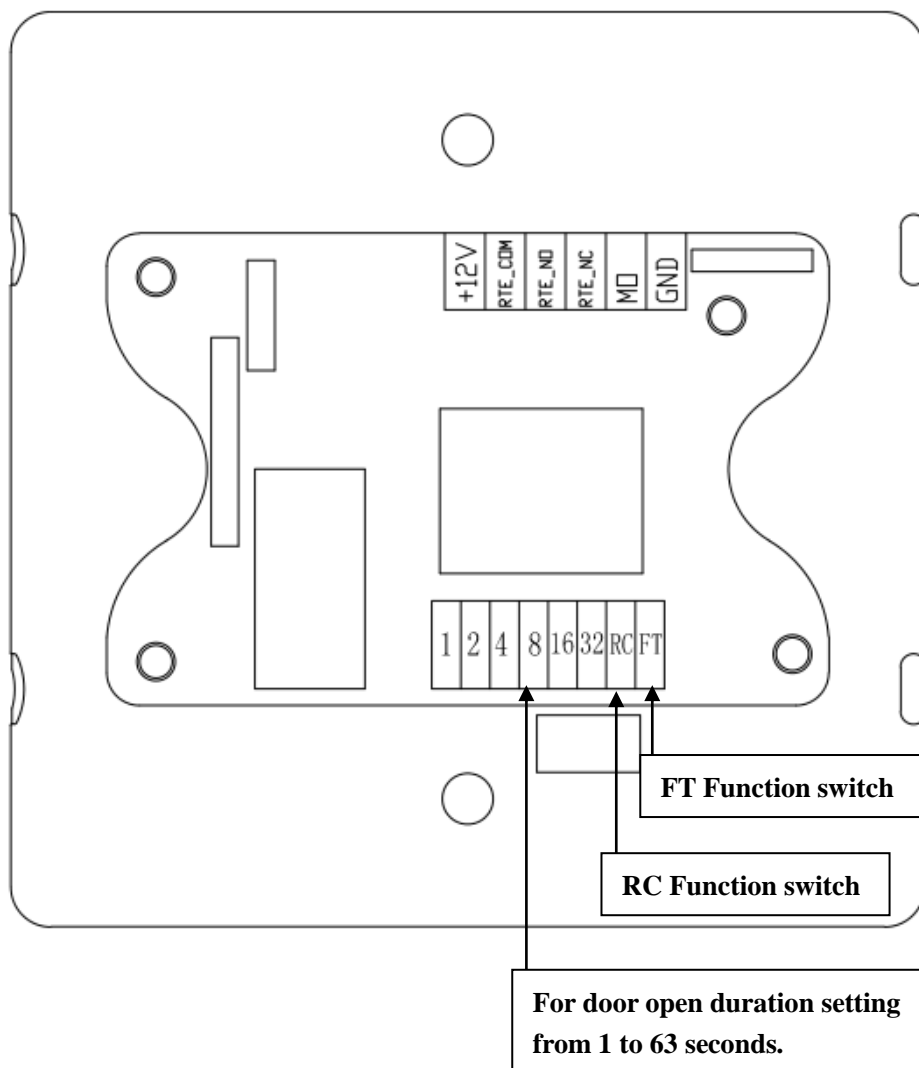

Wiring

Label	Description
+12V	Power Input (+12VDC)
RTE_COM	Exit Button Output (Dry Contact)
RTE_NO	
RTE_NC	
MO	Manual Open Input, Active Low
GND	Signal Ground (0 VDC)

DIP Switch Setting:

1	ON	1	No.1,2,4,8,16,32 are used for adjusting door open duration ON = valid OFF =invalid Door open duration=To add all the ON position switch numbers Example: If we set #1 and #8 to “ON”, the door open during will be: $1+0+0+8+0+0=9$, the decimal number is 9 seconds (decimal number) *Setting all DIP Switch to OFF position means door open duration=1sec.
	OFF	0	
2	ON	2	
	OFF	0	
4	ON	4	
	OFF	0	
8	ON	8	
	OFF	0	
16	ON	16	
	OFF	0	
32	ON	32	
	OFF	0	
RC	ON	RC ON	In certain installation environments, when the device’s maximum capacitive value is reached, setting RC to the ON position can reset the baseline of measured capacitive by offsetting a pre-programmed value to return it to a normalized triggering status.
	OFF	RC OFF	
FT	ON	FT ON	When FT is set to the ON position. a higher triggering threshold value will be adopted to prevent false trigger
	OFF	FT OFF	

Installation:

- 1) Confirm if the size of installation box fits for the REX2 as shown in Fig.1
- 2) Confirm all wirings are in the correct position, then set the jumpers to the right position
- 3) Put the whole module into the installation box and fixed by screw as Fig.2.
- 4) There are 2 M-type buckles at the bottom of the cover as shown in Fig.3. Buckle them into the slot at the bottom of the module and push the upper part of the cover up as Fig.4

Fig.1

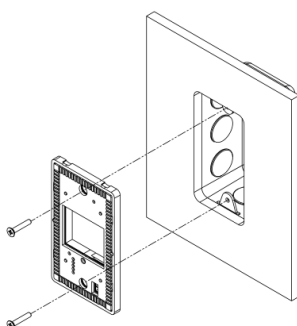
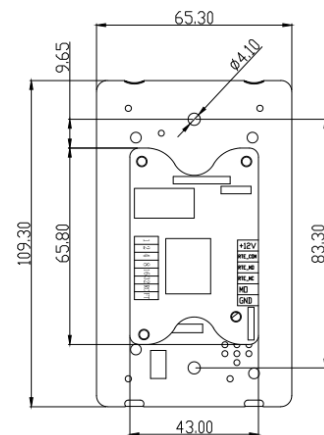
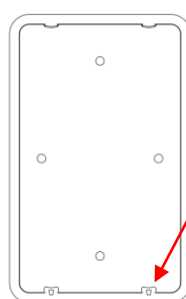

Fig.2



M-type Buckles

Fig.3

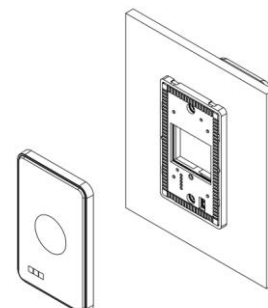

Fig.4

