

# User manual of F-USB-US-V1

## 1. Introduction

F-USB-US-V1 is a ZigBee/ Z-wave Combo module compliant with IEEE802.15.4 MAC/baseband/radio and ITU-T G.9959 optimized for low-power applications.

The ZigBee chipset is from Silicon Labs, part number EM3588-RT and Z-wave chipset is from Sigma Designs, part number SD3503.

## 2. Hardware Architecture:

### 2.1 Main Chipset Information

Item	Vendor	Part Number
IEEE802.15.4	Silicon Labs	EM3588-RT
ITU-T G.9959	Sigma Designs	SD3503

### 2.2 Circuit Block Diagram

The major internal and external block diagram of F-USB-US-V1 is illustrated in Figure 1-1.

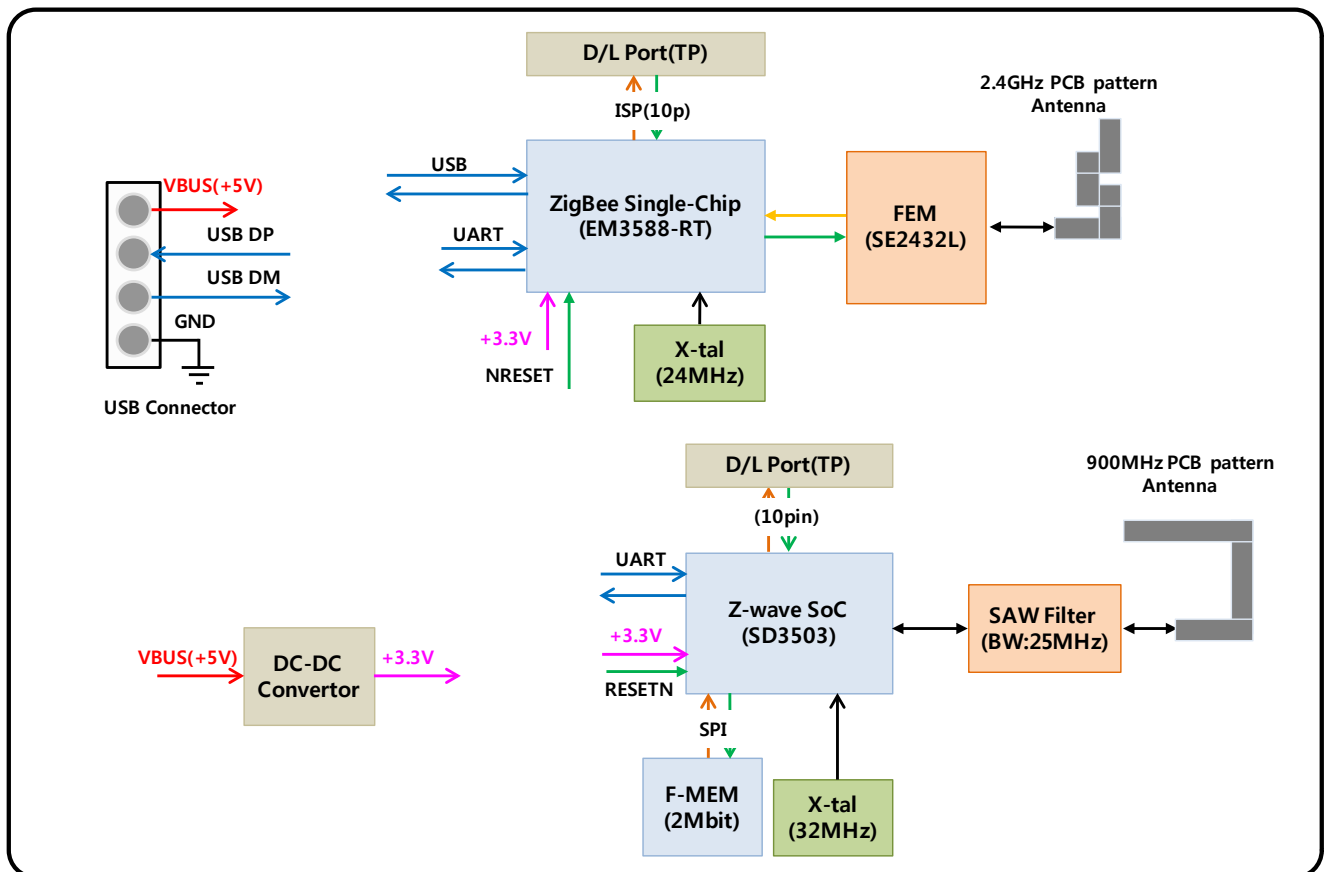

Figure 1-1 F-USB-US-V1 block diagram and System Interface

### 3. Operational Description

F-USB-US-V1 is the 802.15.4 ZigBee, ITU-T G.9959 Z-wave COMBO Module that acts as a communication controller for users of a wireless device to connect to SMART TV

#### - Features

- > ZigBee 2.4GHz IEEE 802.15.4
- > AES128 encryption accelerator
- > Low power consumption, advanced management
- > On-chip power amplifiers and low –noise amplifiers for both bands
- > Z-Wave ITU-T G.9959
- > Z-Wave 9.6/40/100 kbit/s data rate
- > 128-bit AES security processor and hardware random number generator

#### - Time base of the RF frequency

For ZigBee IF and RF frequency, a crystal(24MHz) is a clock reference.

For Z-wave IF and RF frequency, a crystal(32MHz) is a clock reference.

#### - ZigBee Transmission

The ZigBee Tx path produces an O-QPSK-modulated signal using the analog front end and digital baseband. The area- and power-efficient Tx architecture uses a two-point modulation scheme to modulate the RF signal generated by the synthesizer. The modulated RF signal is fed to the integrated PA and then out of the EM357.

#### - ZigBee Receiver

The ZigBee Rx path uses a low-IF, super-heterodyne receiver that rejects the image frequency using complex mixing and polyphase filtering. In the analog domain, the input RF signal from the antenna is first amplified and mixed down to a 4 MHz IF frequency. The mixers' output is filtered, combined, and amplified before being sampled by a 12 MSPS ADC. The digitized signal is then demodulated in the digital baseband. The filtering within the Rx path improves the EM35x's co-existence with other 2.4 GHz transceivers such as Zigbee/ 802.15.4-2003, IEEE 802.11-2007, and Bluetooth radios. The digital baseband also provides gain control of the Rx path, both to enable the reception of small and large wanted signals and to tolerate large interferers.

#### - Z-wave Transceiver

The F-USB-US-V1 is a fully integrated module with an on-board antenna that allows the establishment of a Z-Wave network with minimum risk. The SD3503 chip is used with an external NVM (Serial Flash MEM), 32MHz crystal, power supply decoupling, SAW filter, matching circuit, and a PCB pattern Antenna.

**- Product Details**

> Data Modulation

ZigBee : O-QPSK for 802.15.4

Z-Wave : FSK/GFSK for ITU-T G.9959

> Frequency :

ZigBee

Channel 0x0B(11ch)	2405 MHz
Channel 0x0C(12ch)	2410 MHz
Channel 0x0D(13ch)	2415 MHz
Channel 0x0E(14ch)	2420 MHz
Channel 0x0F(15ch)	2425 MHz
Channel 0x10(16ch)	2430 MHz
Channel 0x11(17ch)	2435 MHz
Channel 0x12(18ch)	2440 MHz
Channel 0x13(19ch)	2445 MHz
Channel 0x14(20ch)	2450 MHz
Channel 0x15(21ch)	2455 MHz
Channel 0x16(22ch)	2460 MHz
Channel 0x17(23ch)	2465 MHz
Channel 0x18(24ch)	2470 MHz
Channel 0x19(25ch)	2475 MHz
Channel 0x1A(26ch)	2480 MHz

Z-wave

Data rate	9.6kbps	40kbps	100kbps	
Modulation	Frequency Shift Keying (FSK)	FSK	Gaussian Frequency Shift Keying (GFSK)	
Frequency deviation	$f_c \pm 20\text{kHz}$	$f_c \pm 20\text{kHz}$	$f_c \pm 29.3\text{kHz}$	
Coding	Manchester encoded	Non-return to Zero (NRZ)	NRZ	
United Arab Emirates	868.42 MHz	868.40 MHz	869.85 MHz	E
Australia	921.42 MHz	921.40 MHz	919.80 MHz	H
Brazil	921.42 MHz	921.40 MHz	919.80 MHz	H
Canada	908.42 MHz	908.40 MHz	916.00 MHz	U
Chile	908.42 MHz	908.40 MHz	916.00 MHz	U
China	868.42 MHz	868.40 MHz	869.85 MHz	E
European Union	868.42 MHz	868.40 MHz	869.85 MHz	E
Hong Kong	919.82 MHz	919.80 MHz	919.80 MHz	H
Israel	916.02 MHz	916.00 MHz	-	U
India	865.20 MHz	865.20 MHz	865.20 MHz	E
Japan	-	-	922.50 MHz	H
	-	-	923.90 MHz	H
	-	-	926.30 MHz	H
Korea	-	-	919.70 MHz	H
	-	-	921.70 MHz	H
	-	-	923.10 MHz	H
Mexico	908.42 MHz	908.40 MHz	916.00 MHz	U
Malaysia	868.12 MHz	868.10 MHz	868.10 MHz	E
New Zealand	921.42 MHz	921.40 MHz	919.80 MHz	H
Russia	869.02 MHz	869.00 MHz	-	E
Singapore	868.42 MHz	868.40 MHz	869.85 MHz	E
Taiwan	-	-	922.50 MHz	H
	-	-	923.90 MHz	H
	-	-	926.30 MHz	H
United States	908.42 MHz	908.40 MHz	916.00 MHz	U
South Africa	868.42 MHz	868.40 MHz	869.85 MHz	E

**- Product pwr Spec.**

Symbol	Parameter	Min	Typ.	Max	Unit
VDD	Power supply	4.5	5	5.5	V

**- Product Spec.**

> ZigBee

Parameter	Min	Typ.	Max	Unit
<b>RF Characteristics</b>				
RF Frequency Range	2.405	-	2.4835	GHz
TX Frequency Tolerance	-74.4	-	74.4	KHz
TX Spurious Emission 30.0MHz to 2.395GHz 2.495GHz to 12.75GHz	-	-	-30	dBm
TX Harmonics 2 <sup>nd</sup> Harmonics 3 <sup>rd</sup> Harmonics	-	-	-30	dBm
Error Vector Magnitude(EVM)	-	-	35	%
RX sensitivity PER at -85dBm	-	-	1	%
RX Spurious Emission 30.0MHz to 12.5GHz	-	-	-54	dBm

Frequency	Power setting Level
2405 MHz	-2
2440 MHz	-2
2475 MHz	-5
2480 MHz	-16

> Z-wave

Parameter	Min	Typ.	Max	Unit
RF Characteristics(NA)				
RF Frequency Range	868.40	-	923.1	MHz
TX Frequency Tolerance	-25.0	-	25.0	KHz
TX Harmonics 2 <sup>nd</sup> Harmonics 3 <sup>rd</sup> Harmonics	-	-	-30	dBm
RX sensitivity PER at -85dBm	-	-	3	%
RX Spurious Emission 30.0MHz to 12.5GHz	-	-	-54	dBm

Frequency (MHz)	Power Setting
908.40	10
908.42	11
916.00	15

#### 4. Installation Guide

##### - Installation Figure

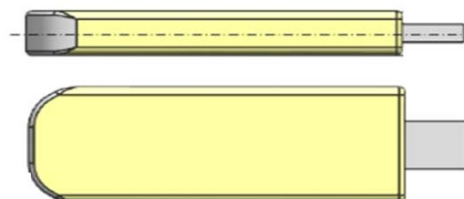

< USB Dongle >



## 5. Notice

### FCC Statement

**This device complies with Part 15 of FCC Rules, Operation is Subject to following two conditions:**

**(1) This device may not cause harmful interference, and**

**(2) This device must accept any interference received including interference that cause undesired operation.**

This equipment has been tested and found to comply within the limits for a Class B digital device, pursuant to part 15 of the FCC Rules. These limits are designed to provide reasonable protection against harmful interference in a residential installation.

This equipment generates, uses, and can radiate radio frequency energy and, if not installed and used in accordance with the instructions, may cause harmful interference to radio communications. However, there is no guarantee that interference will not occur in a particular installation. If this equipment does cause harmful interference to radio or television reception, which can be determined by turning the equipment off and on, the user is encouraged to try to correct the interference by one or more of the following measures:

- Reorient or relocate the receiving antenna
- Increase the separation between the equipment and receiver
- Connect the equipment into an outlet on a different circuit from that to which the receiver is connected
- Consult the dealer or an experienced radio/TV technician for help.

This device and its antenna(s) must not be co-located or operation in conjunction with any other antenna or transmitter.

#### **IMPORTANT NOTE:**

FCC Radiation Exposure Statement;

This equipment complies with FCC radiation exposure limits set forth for an uncontrolled environment.

This equipment should be installed and operated with minimum distance 20cm between the radiator & body.

#### **IMPORTANT NOTE**

This module is intended for OEM integrator. The OEM integrator is still responsible for the FCC compliance Requirement of the end product, which integrates this module.

20cm minimum distance has to be able to be maintained between the antenna and the users for the host this module is integrated into. Under such configuration, the FCC radiation exposure limits set forth for an population / uncontrolled environment can be satisfied.

Any change or modifications not expressly approved by the manufacturer could avoid the user's authority to Operate this equipment.

---

**USER MANUAL OF THE END PRODUCT:**

In the users manual of the end of product, the end user has to be informed to keep at least 20cm separation with the antenna while this end product is installed and operated.

The end user has to be informed that the FCC radio-frequency exposure guidelines for an uncontrolled environment can be satisfied. The end user has to also be informed that any changes or modifications not expressly approved by the manufacturer could void the user's authority to operate this equipment.

if the size of the end product is smaller than 8x10cm, then additional FCC part 15.19 statement is required to be available in the users manual; This device complies with Part 15 of FCC rules.

**LABEL OF THE END PRODUCT:**

The final end product must be labeled in a visible area with the following " Contains TX FCC ID: R3Y-F-USB-US-V1"

"If the size of the end product is larger than 8x10cm, then the following FCC part 15.19 statement has to also be available on the label:

This device complies with Part 15 of FCC rules. Operation is subject to the following two conditions:

(1) this device may not cause harmful interference and (2) this device must accept any interference received, including interference that may cause undesired operation.



---

## IC Statement

This Class B digital apparatus complies with Canadian ICES-003. Operation is subject to the following two conditions: (1) this device may not cause interference, and (2) this device must accept any interference, including interference that may cause undesired operation of the device.

Le présent appareil est conforme aux CNR d'Industrie Canada applicables aux appareils radio exempts de licence. L'exploitation est autorisée aux deux conditions suivantes : (1) l'appareil ne doit pas produire de brouillage, et (2) l'utilisateur de l'appareil doit accepter tout brouillage radioélectrique subi, même si le brouillage est susceptible d'en compromettre le fonctionnement.

This Class B digital apparatus complies with Canadian ICES-003.

Cet appareil numérique de la classe B est conforme à la norme NMB-003 du Canada.

This device and its antenna(s) must not be co-located or operation in conjunction with any other antenna or transmitter.

The device could automatically discontinue transmission in case of absence of information to transmit, or operational failure. Note that this is not intended to prohibit transmission of control or signaling information or the use of repetitive codes where required by the technology.

### IMPORTANT NOTE:

#### IC Radiation Exposure Statement:

This equipment complies with **IC RSS-102** radiation exposure limits set forth for an uncontrolled environment. This equipment should be installed and operated with minimum distance 20cm between the radiator & your body.

### IMPORTANT NOTE:

This module is intended for OEM integrator. The OEM integrator is still responsible for the IC compliance requirement of the end product, which integrates this module.

20cm minimum distance has to be able to be maintained between the antenna and the users for the host this module is integrated into. Under such configuration, the **IC RSS- 102** radiation exposure limits set forth for a population/uncontrolled environment can be satisfied.

Any changes or modifications not expressly approved by the manufacturer could void the user's authority to operate this equipment.

### USERS MANUAL OF THE END PRODUCT:

In the users manual of the end product, the end user has to be informed to keep at least 20cm separation with the antenna while this end product is installed and operated. The end user has to be informed that the IC radio-frequency exposure guidelines for an uncontrolled environment can be satisfied. The end user has to also be informed that any changes or modifications not expressly approved by the manufacturer could void the user's authority to operate this equipment. IC statement is required to be available in the users manual: This Class B digital apparatus complies with Canadian ICES-003.

Operation is subject to the following two conditions: (1) this device may not cause harmful interference and (2) this device must accept any interference received, including interference that may cause undesired operation.



---

**LABEL OF THE END PRODUCT:**

The final end product must be labeled in a visible area with the following " Contains TX IC:10734A-FUSBUSV1"