

# **Instructions for Use**

Combi Steam oven

# **Bedienungsanleitung**

Combi Dampfgarer

SA45VCX2 combi steam oven



1	PRECAUTIONS FOR USE.....	1
2	DISPOSAL INSTRUCTIONS - OUR ENVIRONMENT POLICY .....	1
3	SAFETY PRECAUTIONS.....	2
4	GET TO KNOW YOUR OVEN.....	5
5	ACCESSORIES AVAILABLE .....	5
6	BEFORE INSTALLATION .....	6
7	DESCRIPTION OF FRONT PANEL CONTROLS .....	7
8	USING THE OVEN.....	9
9	WATER FEEDING.....	10
10	SELECTING THE FUNCTION.....	11
11	RECOMMENDED COOKING TABLES .....	23
12	CARE AND MAINTENANCE .....	29
13	OVEN CLEANING .....	32
14	EXTRAORDINARY MAINTENANCE.....	33
15	INSTALLING THE APPLIANCE .....	35

**INSTRUCTIONS FOR THE USER:** these provide recommendations for use, a description of the controls and the correct procedures for cleaning and maintaining the appliance



**INSTRUCTIONS FOR THE INSTALLER:** these are intended for the **qualified engineer** who is to install, commission and test the appliance





## 1 PRECAUTIONS FOR USE



THIS MANUAL IS AN INTEGRAL PART OF THE APPLIANCE. TAKE GOOD CARE OF IT AND KEEP IT TO HAND THROUGHOUT THE OVEN'S LIFE CYCLE. WE URGE YOU TO READ THIS MANUAL AND ALL THE INFORMATION IT CONTAINS CAREFULLY BEFORE USING THE APPLIANCE. INSTALLATION MUST BE CARRIED OUT BY QUALIFIED STAFF IN COMPLIANCE WITH THE RELEVANT REGULATIONS. THIS APPLIANCE IS INTENDED FOR HOUSEHOLD USE AND COMPLIES WITH THE EEC DIRECTIVES CURRENTLY IN FORCE. THE APPLIANCE IS BUILT TO PROVIDE THE FOLLOWING FUNCTION: COOKING AND HEATING FOODS; ALL OTHER USES ARE TO BE CONSIDERED IMPROPER. THE MANUFACTURER DECLINES ALL LIABILITY FOR USES OTHER THAN THOSE STATED ABOVE. KEEP THE DOCUMENTATION OF THIS PRODUCT FOR FUTURE REFERENCE. ALWAYS KEEP THE INSTRUCTION MANUAL HANDY. IF YOU LEND THE STEAMER TO SOMEONE ELSE GIVE THEM THE MANUAL AS WELL!



NEVER USE THIS APPLIANCE FOR HEATING ROOMS.



NEVER LEAVE PACKAGING RESIDUES UNATTENDED IN THE HOME. SEPARATE THE VARIOUS PACKAGING MATERIALS BY TYPE AND CONSIGN THEM TO THE NEAREST SEPARATE DISPOSAL CENTRE.



THIS APPLIANCE IS TAGGED UNDER EUROPEAN DIRECTIVE 2002/96/EC ON WASTE ELECTRICAL AND ELECTRONIC EQUIPMENT (WEEE). THIS DIRECTIVE CONTAINS THE REGULATIONS GOVERNING THE COLLECTION AND RECYCLING OF DECOMMISSIONED APPLIANCES THROUGHOUT THE EUROPEAN UNION.



NEVER OBSTRUCT THE OPENINGS AND SLITS PROVIDED FOR VENTILATION AND HEAT DISPERSAL.



THE NAMEPLATE WITH THE TECHNICAL DATA, SERIAL NUMBER AND MARK IS IN A VISIBLE POSITION ON THE OVEN DOOR FRAME. THE NAMEPLATE MUST NEVER BE REMOVED.



NEVER USE METAL SCOURING PADS OR SHARP SCRAPERS WHICH WILL DAMAGE THE SURFACE. USE ORDINARY NON-ABRASIVE PRODUCTS WITH THE AID OF WOODEN OR PLASTIC UTENSILS IF NECESSARY. RINSE THOROUGHLY AND DRY WITH A SOFT CLOTH OR CHAMOIS LEATHER.





## **2 *DISPOSAL INSTRUCTIONS - OUR ENVIRONMENT POLICY***

By ensuring this product is disposed of correctly, you will help prevent potential negative consequences for the environment and human health, which could otherwise be caused by inappropriate waste handling of this product. The symbol on the product indicates that this product may not be treated as household waste. Instead it shall be handed over to the applicable collection point for the recycling of electrical and electronic equipment.

Disposal must be carried out in accordance with local environmental regulations for waste disposal. For more detailed information about treatment, recovery and recycling of this product, please contact your local city council office.

## 3 SAFETY PRECAUTIONS



REFER TO THE INSTALLATION INSTRUCTIONS FOR THE SAFETY REGULATIONS FOR ELECTRIC OR GAS APPLIANCES AND VENTILATION FUNCTIONS.

IN YOUR INTEREST AND TO ENSURE YOUR SAFETY, BY LAW ALL ELECTRIC APPLIANCES MUST ONLY BE INSTALLED AND SERVICED BY QUALIFIED STAFF, IN ACCORDANCE WITH THE RELEVANT REGULATIONS.

OUR APPROVED INSTALLATION ENGINEERS GUARANTEE YOU A JOB WELL DONE.

GAS OR ELECTRIC APPLIANCES MUST ALWAYS BE DISCONNECTED BY SUITABLY SKILLED PEOPLE.



THE PLUG TO BE CONNECTED TO THE POWER SUPPLY LEAD AND THE RELATIVE SOCKET MUST BE OF THE SAME TYPE AND COMPLY WITH THE RELEVANT REGULATIONS.

THE POWER SUPPLY SOCKET MUST BE ACCESSIBLE EVEN AFTER THE APPLIANCE HAS BEEN BUILT-IN.

NEVER DISCONNECT THE PLUG BY PULLING ON THE POWER SUPPLY LEAD



THE APPLIANCE MUST BE CONNECTED TO EARTH IN COMPLIANCE WITH ELECTRICAL SYSTEM SAFETY REGULATIONS.



IMMEDIATELY AFTER INSTALLATION, CARRY OUT A QUICK TEST ON THE OVEN FOLLOWING THE INSTRUCTIONS PROVIDED LATER IN THIS MANUAL. IF THE APPLIANCE FAILS TO OPERATE, DISCONNECT IT FROM THE ELECTRICAL MAINS AND CONTACT YOUR NEAREST SERVICE CENTRE. NEVER ATTEMPT TO REPAIR THE APPLIANCE.



**WARNING!** NEVER LEAVE THE OVEN UNSUPERVISED.

**WARNING!** IF YOU SEE SMOKE OR FIRE, KEEP THE DOOR CLOSED IN ORDER TO SMOTHER THE FLAMES. SWITCH OFF THE OVEN AND TAKE THE PLUG OUT OF THE SOCKET OR CUT OFF THE OVEN POWER SUPPLY.

**WARNING!** OVERHEATED FAT AND OIL CAN EASILY CATCH FIRE. HEATING OIL IN THE COOKING SPACE TO SEAR MEAT IS DANGEROUS AND SHOULD NOT BE DONE. NEVER TRY TO EXTINGUISH BURNING OIL OR FAT WITH WATER (DANGER OF EXPLOSION)! SMOTHER THE FLAMES WITH A DAMP CLOTH AND KEEP ALL DOORS AND WINDOWS CLOSED.



**WARNING!** DO NOT USE ALCOHOL TO COOK IN THE OVEN. IT CAN CAUSE THE OVERHEATING OF THE FOOD. DANGER OF EXPLOSION!



**WARNING!** THE APPLIANCE AND ITS ACCESSIBLE PARTS BECOME HOT DURING USE. CARE SHOULD BE TAKEN TO AVOID TOUCHING HEATING ELEMENTS. CHILDREN LESS THAN 8 YEARS OF AGE SHALL BE KEPT AWAY UNLESS CONTINUOUSLY SUPERVISED.

THIS APPLIANCE CAN BE USED BY CHILDREN AGED FROM 8 YEARS AND ABOVE AND PERSONS WITH REDUCED PHYSICAL, SENSORY OR MENTAL CAPABILITIES OR LACK OF EXPERIENCE AND KNOWLEDGE IF THEY HAVE BEEN GIVEN SUPERVISION OR INSTRUCTION CONCERNING USE OF THE APPLIANCE IN A SAFE WAY AND UNDERSTAND THE HAZARDS

## Safety Precautions

INVOLVED. CHILDREN SHALL NOT PLAY WITH THE APPLIANCE. CLEANING AND USER MAINTENANCE SHALL NOT BE MADE BY CHILDREN WITHOUT SUPERVISION.

**WARNING:** ACCESSIBLE PARTS MAY BECOME HOT DURING USE. YOUNG CHILDREN SHOULD BE KEPT AWAY.

**WARNING:** DURING USE THE APPLIANCE BECOMES VERY HOT. CARE SHOULD BE TAKEN TO AVOID TOUCHING HEATING ELEMENTS INSIDE THE OVEN. RISK OF BURNS!

**WARNING! WHEN OPENING THE DOOR DURING OR UPON COMPLETION OF THE COOKING CYCLE, BE CAREFUL OF THE FLOW OF HOT AIR AND/OR STEAM AND WATER DROPS COMING OUT OF THE COOKING CHAMBER. STEP BACK OR TO THE SIDE TO AVOID BURNS.**



**WARNING!** MAKE SURE YOU NEVER CATCH THE POWER CABLES OF OTHER ELECTRICAL APPLIANCES IN THE HOT DOOR OR THE OVEN. THE CABLE INSULATION MAY MELT. **DANGER OF SHORT-CIRCUITING!**



**THIS OVEN IS EXCLUSIVELY FOR DOMESTIC USE!**

**THE APPLIANCE IS DESIGNED FOR USE IN THE HOME FOR PREPARING FOOD. NO LIABILITY IS ASSUMED FOR ANY DAMAGE CAUSED BY IMPROPER OR INCORRECT USE.**

AVOID DAMAGING THE OVEN OR OTHER DANGEROUS SITUATIONS BY FOLLOWING THESE INSTRUCTIONS:

- Do not cover or obstruct the **ventilation openings**.
- Do not keep any **flammable object** inside the oven as it may burn if the oven is switched on.
- Do not use the oven as a **pantry**.
- Do not pour spirits (e.g. brandy, whisky, schnapps, etc.) over hot food. **DANGER OF EXPLOSION!**
- Accessories such as wire racks and trays, etc. get hot in the cooking space. Always wear protective gloves or use oven cloths.
- **To avoid being burnt**, always use oven gloves for handling dishes and containers and touching the oven.
- **Do not lean or sit on the open oven door**. This may damage the oven, especially in the hinge zone. The door can bear a maximum weight of 8 kg.
- The racks can bear a maximum load of 8 kg. To avoid damaging the oven, do not exceed this load.

## CLEANING:

- The appliance will remain hot for some time after it is switched off and cool down only slowly to room temperature. Please allow sufficient time for the appliance to cool down before, for instance, cleaning it.
- DO NOT USE HARSH ABRASIVE CLEANERS OR SHARP METAL SCRAPERS TO CLEAN THE OVEN DOOR GLASS SINCE THEY CAN SCRATCH THE SURFACE, WHICH MAY RESULT IN SHATTERING OF THE GLASS.
- The door contact surfaces (the front of the cooking space and the inside part of the doors) must be kept very clean in order to ensure the oven functions correctly.
- Please follow the instructions regarding cleaning in the section "Oven Cleaning and Maintenance".

## REPAIRS:

- If the supply cord is damaged, it must be replaced by the manufacturer or its service agent or a similarly qualified person in order to avoid a hazard. Furthermore, special tools are required for this task.
- Repair and maintenance work, especially of current carrying parts, can only be carried out by technicians authorised by the manufacturer.



*The manufacturer declines all responsibility for injury or damage caused by failure to comply with the above regulations or deriving from tampering with even just one part of the appliance and the use of non-original spare parts.*



## 4 GET TO KNOW YOUR OVEN

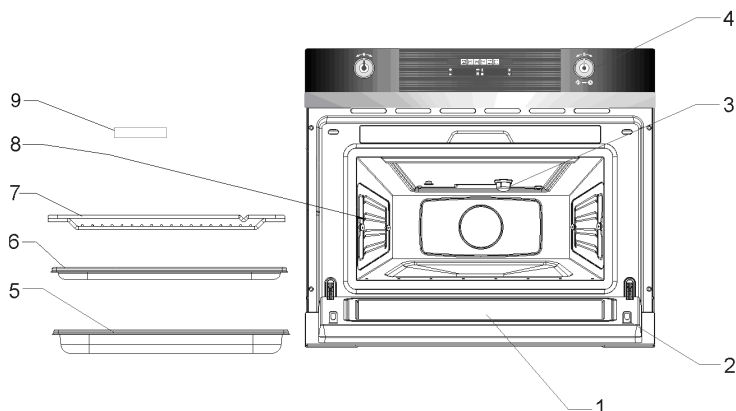

- |                           |                               |
|---------------------------|-------------------------------|
| 1. – Door window glass    | 6. – Non-perforated container |
| 2. – Catches              | 7. – Rack                     |
| 3. – Lamp                 | 8. – Shelf guides             |
| 4. – Control panel        | 9. – Sponge                   |
| 5. – Perforated container |                               |

## 5 ACCESSORIES AVAILABLE

**Perforated container:** suitable for cooking fresh or deep frozen vegetables, meat and poultry.

**Non-perforated container:** suitable for steaming sensitive foods, e.g. compotes and dumplings. You can use it with the perforated container to catch the water.

**Rack:** used when cooking with small containers, as for example, dessert bowls and to regenerate plate dishes.

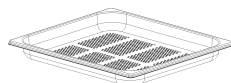

Oven accessories which may come into contact with foods are made from materials compliant with the EC Regulation 1935-2004 and national relevant regulations.



## Instructions for the User

EN

### **6 BEFORE INSTALLATION**



Never leave packaging residues unattended in the home. Separate waste packaging materials by type and consign them to the nearest separate disposal centre.



The inside of the appliance should be cleaned to remove all manufacturing residues. For further information about cleaning, see point "CARE AND MAINTENANCE".



## 7 DESCRIPTION OF FRONT PANEL CONTROLS

All the appliance's control and monitoring devices are placed together on the front panel. The table below provides the key to the symbols used.

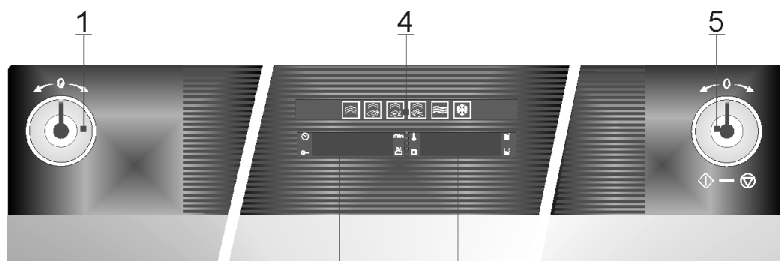

**1**  
PT1

**Function's parameters knob**

This knob allows you to set the time, select the cooking temperature and duration and program the cooking start and end times. From now on, for convenience it will be referred to as PT1.



**5**  
PT2

**Function-switch on knob**

This knob allows access to the oven's three operating settings, and is also used to select a cooking function (see point "8.2 Operating settings").

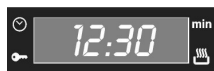

**2**  
DSP1

**Current time / Duration display**

This display shows the current time or the cooking duration. Also visible are the function cut-out light



**Clock** Adjusting the cooking time



**Child lock out function**

Child lock-out function mode on (see point "10.3.4 Child safety lock-out function")



**Cooking duration**

Setting the cooking duration



**Delayed start**

Setting the cooking time with a delayed start



# Instructions for the User

EN



**3**  
DSP2

**Temperature / Type of food display**

This display shows the Parameters set for the function required, or the Parameters set by the user.



**Temperature**

The oven is heating up

**Descalc function**

See point 10.3.2 Descalc function



**Water level indication**

Indicates the existing water quantity in the tank (see point 9.2 Water levels indication)



**4**  
DSP3

**Function display**

This display shows (illuminated) all the cooking functions available for selection. For instructions on how to select a cooking function, see point "10 Selecting a cooking function".

The table below provides a list of the functions available.  
Please see chapter 10 for a more detailed description of the functions

	STEAM		VEGETABLES COOKING
	MEAT COOKING		REHEATING & STERILISING
	FISH COOKING		DEFROSTING
	GRILL ELEMENT		PIZZA FUNCTION
	HOT AIR		HOT AIR + GRILL
	HOT AIR + STEAM		



## 8 USING THE OVEN

### 8.1 Precautions and General Advice



When the oven is used for the first time, it should be heated to the maximum temperature for long enough to burn off any oily residues left by the manufacturing process, which might contaminate foods with unpleasant smells.

The accessories can contain hot water when they are taken from the oven, therefore the use of gloves and particular attention are always recommended



Oven accessories which may come into contact with foods are made from materials compliant with the EC Regulation 1935-2004 and national relevant regulations.

### 8.2 Operating settings

This product is programmed to provide 3 operating settings, which can be modified by pressing PT2.

**Standby setting:** activated as soon as the current time has been confirmed, with DSP1 on and showing the current time.

**ON setting:** from the standby setting, press PT2 once. All the displays and knobs light up.

**OFF setting:** from the ON setting, press PT2 once.

Only the symbol  on DSP1 remains on.

**The heating system is not activated immediately in any of these functions, in order to improve operator safety.**

### 8.3 First Use

At first use, or after a power failure, the oven's left hand-display, DSP1, will show a flashing  symbol. The oven will not operate until the clock, the water hardness parameter and the calibration is set.

#### 8.3.1 Setting the current time and the water hardness level

To set the current time, turn PT1 to the right and left to increase or decrease the hours.

Press PT1 once to move on to setting the minutes. Turn it to the right and left to increase or decrease the minutes.

Press PT1 again to confirm the current time and move on to water hardness level setting. The DSP2 will show the word "Dur" and DSP1 will show the water hardness level "MED" (pre-set value).

Turn PT1 to the right and left to change the water hardness level value, as described in table below



# Instructions for the User

EN

Press PT1 to confirm the water hardness level.

TYPE	WATER HARDNESS				disp 1
	Ca + Mg (ppm)	English deg. [°dH]	French deg. [°dF]	German deg. [°dH]	
SOFT WATER	0 TO 150	0 TO 11	0 TO 15	0 TO 8	SOFT
MEDIUM WATER	151 TO 350	12 TO 25	16 TO 35	9 TO 20	MED
HARD WATER	301 TO 500	26 TO 35	36 TO 50	21 TO 28	HARD

### 8.3.2 Water Level calibration

After setting the water hardness, appears  in the Display and the water level lights shine.

Please take the Water tank completely off. Wait until the display and the water tank lights disappear.

### 8.3.3 Changing the current time

It might become necessary to change the current time, for example at the switch from summer to winter time. To do this, starting from the standby setting (see point “8.2 Operating settings”) keep PT1 pressed for a few seconds until the figures on DSP1 flash. Now repeat the operations described in point “8.3.1 Setting the current time and water hardness level”.

### 8.3.4 Changing the current water hardness level

It might become necessary to change the current water hardness level. To do this, please refer to point “10.3.3 changing the water hardness level”.

## 9 WATER FEEDING

All functions require the water tank to be full.

Fill the water tank up to the “MAX” mark, which is in the water tank, with cold, fresh drinking water and introduce it into the slot located above the cavity (recommended 1,2 L, maximum 1,4 L).

If the indication “rES” appears, it means that the water tank was not properly inserted.

### 9.1 Refilling the water

The contents of the water tank normally suffice for one cooking session of 50-60 minutes.

If, however, the water tank needs to be refilled, the water refill light starts

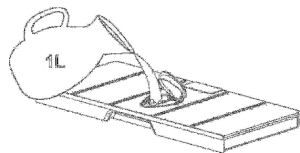

to flash . **Only fill the water tank up to a maximum of 0.5 litres to ensure that the water does not overflow when it is pumped back to the water tank. RISK OF OVERFLOW.**





### 9.2 Water levels indication

The steamer indicates the existing water quantity in the tank through 3 levels, which correspond to the following percentages:

-  – 0% to 20%
-  – 20% to 60%
-  – 60% to 100%

Remark: don't refill the tank, if it's placed. Please remove it completely and wait > 20 sec. before placing it again.

### 9.3 Emptying the water tank

When the appliance is switched off, the residual water is pumped back into the water tank.

While the water is being pumped the display shows "PUMP".

This message stays on until the temperature of the water reaches 75° C before it can be pumped back to the water tank.

If the display shows "FULL" it means that the water has too much water inside. Please empty the tank and place it again.

**Warning: the water in the tank may be hot. Danger of burns!**

After the water is pumped back to the water tank, the display will show the message "DEP" requiring the following actions:

1. Remove and empty the water tank.
2. Dry the water tank and introduce it back into the slot located above the cavity. Clean and dry the cooking space.
3. Leave the appliance door open so that the cooking space can cool down and dry completely.

**IMPORTANT NOTE: It is advisable to remove the water tank and empty it after a cooking cycle. This prevents the formation of bacteria and limestone inside the appliance.**

**Don't wash the water tank in the dishwasher machine.**

If the water tank has not been removed from the oven and a new cooking cycle is started, the oven displays the warning "DEP".

This warning can be cleared by pressing PT2 and proceed with the new cooking cycle without removing and emptying the water tank.

## 10 SELECTING THE FUNCTION

In the ON state only, a cooking function can be selected by simply turning PT2 to the right or left. The function selected will change colour to orange on DSP3. The preset cooking time will be displayed on DSP1 and the preset parameters (temperature, food type) are displayed on DSP2.



The suggested times and temperatures are guideline values. The actual cooking time can vary according to the type and quality of the foods.



# Instructions for the User





EN

## 10.1.1 Steam function (Manual program)

After selecting this function, press PT1 to modify the preset parameters of cooking time and temperature. The temperature light  starts to blink. Turn PT1 to the right or left to change the preset temperature. Press PT1 to validate and the cooking duration light  starts to blink. Turn PT1 to the right or left to change the preset cooking duration. Please consider the information on the cooking table (see point 10). Press PT2 to immediately start the cooking process or otherwise press PT1 to set a different time for the cooking process start (please refer to point "10.1.7 Delayed Start Time").

## 10.1.2 Meat Cooking function (Automatic program)

After selecting this function, press PT1 to modify the preset parameters and the DSP2 starts to blink. Turn PT1 to the right or left to change the preset food type displayed on DSP2. The cooking duration is calculated based on the food's type but can be changed by pressing PT1. Turn PT1 to the right or left to change the preset cooking duration. Press PT2 to immediately start the cooking process or otherwise press PT1 to set a different time for the cooking process start (please refer to point "10.1.7 Delayed Start Time"). The temperature will be automatically set to achieve the best results. The following table shows the programmes, indicating the time that the function will take.

PROGRAM	TYPE OF MEAT	TEMPERATURE °C	TIME (MIN)	CONTAINER	LEVEL
C 1	 CHICKEN BREAST	100 °C	30	PERFORATED	2
C 2	 SMOKED PORK LOIN / PIECES	100 °C	45	PERFORATED	2
C 3	 TURKEY ESCALOPE	100 °C	20	PERFORATED	2
C 4	 PORK FILET, WHOLE	100 °C	25	PERFORATED	2
C 5	 VIENNA SAUSAGES	90 °C	15	PERFORATED	2

## 10.1.3 Fish Cooking function (Automatic program)

After selecting this function, press PT1 to modify the preset parameters and the DSP2 starts to blink. Turn PT1 to the right or left to change the preset food type displayed on DSP2. The cooking duration is calculated based on the food's type but can be changed by pressing PT1. Turn PT1 to the right or left to change the preset cooking duration.





## Instructions for the User



Press PT2 to immediately start the cooking process or otherwise press PT1 to set a different time for the cooking process start (please refer to point "7.4.7 Delayed Start Time").

The temperature will be automatically set to achieve the best results.

The following table shows the programmes, indicating the time that the function will take.

PROGRAM		TYPE OF FISH	TEMPERATURE °C	TIME (MIN)	CONTAINER	LEVEL
b 1		TROUT	80 °C	25	PERFORATED	2
b 2		SHRIMP	90 °C	15	PERFORATED	2
b 3		FISH FILET	80 °C	18	PERFORATED	2
b 4		MUSSELS	100 °C	25	PERFORATED	2
b 5		LOBSTER	100 °C	30	PERFORATED	1/2

### 10.1.4 Vegetables Cooking function (Automatic program)

After selecting this function, press PT1 to modify the preset parameters and the DSP2 starts to blink.

Turn PT1 to the right or left to change the preset food type displayed on DSP2.





The cooking duration is calculated based on the food's type but can be changed by pressing PT1.

Turn PT1 to the right or left to change the preset cooking duration.

Press PT2 to immediately start the cooking process or otherwise press PT1 to set a different time for the cooking process start (please refer to point "10.4.7 Delayed Start Time").

The temperature will be automatically set to achieve the best results.

The following table shows the programmes, indicating the time that the function will take.

PROGRAM		FOOD	TEMPERATURE (°C)	TIME (MIN)	CONTAINER	LEVEL
A 1		BROCCOLI	100 °C	20	PERFORATED	2
A 2		CARROTS	100 °C	25	PERFORATED	2
A 3		POTATOES AND MIXED VEGETABLES	100 °C	25	PERFORATED	2
A 4		SNOW PEAS	100 °C	15	PERFORATED	2
A 5		ASPARAGUS	100 °C	25	PERFORATED	2

### 10.1.5 Re-Heating and Sterilising function (Automatic program)

After selecting this function, press PT1 to modify the preset parameters and the DSP2 starts to blink.



# Instructions for the User

EN

Turn PT1 to the right or left to change the preset food type displayed on DSP2.







The cooking duration is calculated based on the food's type but can be changed by pressing PT1.

Turn PT1 to the right or left to change the preset cooking duration.

Press PT2 to immediately start the defrost process or otherwise press PT1 to set a different time for the defrost process start (please refer to point "10.1.7 Delayed Start Time").

The temperature will be automatically set to achieve the best results.

The following table shows the programmes, indicating the time that the function will take.

PROGRAM	TYPE OF FOOD	TEMPERATURE °C	TIME (MIN)	INSTRUCTIONS	CONTAINER	LEVEL
r 1	 PLATE DISHES	100°C	13		RACK	2
r 2	 READY-MADE MEALS / FROZEN	100°C	18	REMOVE LID FROM CONTAINER AND PUT ON RACK.	RACK	2
r 3	 BEANS	100°C	35	STERILISING: THE TIMES AND TEMPERATURE S REFER TO 1L PRESERVING JARS.	RACK	2
r 4	 CHERRIES	80°C	35		RACK	2
r 5	 PLUMS	90°C	35		RACK	2
r 6	 BABY BOTTLES	100°C	12		RACK	2

## 10.1.6 Grill Element function

After selecting this function press PT1 to set the parameters and the duration light  starts to blink. Turn PT1 to the right or left to change the preset cooking duration. Press PT1 to validate.

Press PT2 to immediately start the cooking process or otherwise press PT1 to set a different time for the cooking process start (please refer to point "7.4.11 Delayed Start Time (Automatic cooking)").

## 10.1.7 Grill Element + Fan function

After selecting this function **press PT1 to set the parameters and the duration light  starts to blink.** Turn PT1 to the right or left to change the preset cooking duration.

Press PT1 to validate.

Press PT2 to immediately start the cooking process or otherwise press PT1 to set a different time for the cooking process start (please refer to point. Delayed Start Time (Automatic cooking)").

The temperature light  will blink until the cavity temperature has reached the set value.



### 10.1.8 Hot Air function



After selecting this function **press PT1 to set the parameters and the duration light  starts to blink.** Turn PT1 to the right or left to change the preset cooking duration.

Press PT1 to validate.

Press PT2 to immediately start the cooking process or otherwise press PT1 to set a different time for the cooking process start.

The temperature light  will blink until the cavity temperature has reached the set value.

### 10.1.9 Pizza function

After selecting this function **press PT1 to set the parameters and the duration light  starts to blink.** The weight light  starts to blink.

Turn PT1 to the right or left to change the preset Pizza weight.

### 10.1.10 Special Functions

Chose the *Bread and Pizza/Gratin* , *Meat* , *Fish* , *Vegetables*  or *Reheating & Sterilising*  function in *DSP3* by rotating and pressing *PT2*.

The display *DSP1* shows the cooking time by default for the program displayed in *DSP2* which also alternates with the predetermined temperature. The following screens show the first program corresponding to each one of the five *Special Functions* listed in 1





# Instructions for the User

EN

Press *PT1* to enter the Special Function and rotate it to select a program, the program starts to blink. The selection is linear from “X1” to “X5”, “X6” or “X14”, corresponding “X” to “A”, “B”, “C”, “P” or “R”. While the Special Function is being set the temperature is not displayed. Only the Special Function is displayed blinking.

Press the *PT1* knob to validate the program and enter the *Cooking Time* and rotate it to set a new value, the *Cooking Time* value and symbol  start to blink.

Press the *PT1* knob to validate the *Cooking Time* and enter the *Delayed Start*.

The display *DSP1* shows the actual *Clock* value and *DSP2* “AUTO”.

In *Delayed Start* rotate *PT1* to set a new time value, the time value in *DSP1* and *Delayed Start* symbol  start to blink”. The selection is circular from 0:00 minutes to 23:59 hours in one minute steps.

Press *PT2* to initiate the program.

If a *Delayed Start* is set the program will only be initiated when the *Clock* equals the time value set in 8. Until the program is initiated the displays *DSP1* and *DSP2* will present the *Cooking Time* and *Temperature* alternating with the *Delayed Start*. The *Delayed Start* can be override by pressing *PT2* again.

The temperature light  will blink until the cavity temperature has reached the set value. **Press *PT2* to start the cooking process.**

The following table shows the four *Special Functions*, their programs, temperatures and cooking times.

Function	Program	Temperature (°C)	Duration (min.)
<b>Bread &amp; Pizza/Gratin</b>			
	P1	200	15
	P2	200	20
	P3	180	25
	P4	190	50
	P5	200	40
	P6	200	60
	P7	190	70
	P8	180	70
	P9	160	60
	P10	160	50
	P11	180	35
	P12	180	30
	P13	220	15
	P14	230	15



Function	Program	Temperature (°C)	Duration (min.)
<b>Meat</b>			
	C1	100	30
	C2	100	45
	C3	100	20
	C4	100	25
	C5	90	15
<b>Fish</b>			
	B1	80	25
	B2	90	15
	B3	80	18
	B4	100	25
	B5	100	30
<b>Vegetables</b>			
	A1	100	20
	A2	100	25
	A3	100	25
	A4	100	15
	A5	100	25
<b>Reheating &amp; Sterilising</b>			
	R1	100	13
	R2	100	18
	R3	100	35
	R4	80	35
	R5	90	35
	R6	100	12

### 10.1.11 Defrost function (Manual program)

After selecting this function, press PT1 to modify the preset cooking duration and the DSP1 starts to blink.

Turn PT1 to the right or left to change the preset defrosting duration.

Please consider the information on the defrosting table (see point 10).

Press PT2 to immediately start the defrost process or otherwise press PT1 to set a different time for the defrost process start (please refer to point "10.1.7 Delayed Start Time").

### 10.1.12 Delayed Start Time

When PT1 is pressed to define a delayed start time the corresponding light  starts to blink, DSP1 shows the current time and DSP 2 shows "Auto".

Turn PT1 to the right or left to change the delayed start time.

Press PT2 to validate the delayed start time.

The oven enters in an idle state waiting for the defined start time. DSP3 shows the selected function and DSP1 and DSP2 show all the defined parameters for the function continuously alternating.

If you wish to start the function before the selected time, just press PT2.

If you wish to cancel the programming, press PT2 for 3 seconds.



# Instructions for the User

EN



## **10.2 When the oven is working...**

IT IS NORMAL THAT SOME STEAM ESCAPES THROUGH THE OPENING BETWEEN THE DOOR AND CONTROL PANEL DURING THE HEATING PERIOD. THE AMOUNT OF RELEASED STEAM WILL BE REDUCED WHEN THE OVEN REACHES THE SET TEMPERATURE.

### **10.2.1 Interrupting a cooking cycle**

You can stop the cooking process at any time by pressing the PT2 key once or by opening the oven door.

The oven incorporates a steam-reduction function that is activated when the Start/Stop key is pressed to gradually release the steam from the cavity, so that there is no sudden rush of steam when the appliance door is opened.

This function takes around 3 minutes and during it the display shows the word "VAP".



**WARNING! WHEN OPENING THE DOOR DURING OR COMPLETION OF THE COOKING CYCLE WITHOUT STOPPING IT AS DESCRIBED ABOVE BE CAREFUL OF THE FLOW OF HOT AIR AND/OR STEAM COMING OUT OF THE COOKING CHAMBER. STEP BACK OR TO THE SIDE TO AVOID BURNS.**

At this point:

- Steam generation is stopped immediately although steam continues to be produced until the water cools down in the boiler.
- The cavity walls and the water tank are still very hot. Danger of burning!
- The timer stops and the display shows the remaining amount of operating time.

If you wish, at this time you can:

- Turn or stir the food to ensure it will be evenly cooked.
- Modify the process parameters.
- Cancel a cooking cycle
- End of a cooking cycle.

To restart the process, close the door and press PT2.

### **10.2.2 Modifying parameters**

The operating parameters (time, temperature, etc.) can only be modified when the cooking process has been interrupted. Proceed as follows:

- Press PT1 to activate the parameter modification mode. The **min** symbol starts to blink. Turn PT1 to the right or left to change the remaining cooking duration.
- Press PT1 to validate and the next parameter light starts to blink. Proceed as described in the active function chapter to modify the remaining parameters.
- Press PT2 to continue the cooking process.

### **10.2.3 Cancelling a cooking cycle**

If you wish to cancel the cooking process, press PT2 for 3 seconds.



You will then hear a beep and the oven will be in the condition described in the following paragraph (10.2.4)

### 10.2.4 End of a cooking cycle

At the end of the set duration or when you press PT2 to finish the cooking cycle, you will hear three beeps and the display will show the word "End" flashing, the oven starts the steam-reduction function.

This function gradually releases the steam from the cavity, so that there is no sudden rush of steam when the appliance door is opened.

This function takes around 3 minutes and during it the display shows the word "VAP". If you want to start a new cooking cycle press PT2 and rotate.

**WARNING! WHEN OPENING THE DOOR DURING OR COMPLETION OF THE COOKING CYCLE WITHOUT STOPPING IT AS DESCRIBED, BE CAREFUL OF THE FLOW OF HOT AIR AND/OR STEAM COMING OUT OF THE COOKING CHAMBER. STEP BACK OR TO THE SIDE TO AVOID BURNS.**

**The cooling fan can continue to run for a certain length of time after the appliance has been switched off. This is a normal function that is meant to reduce the temperature inside the oven.**

In the meantime, as soon as the water in the boiler reaches below 75 °C it is pumped back to the water tank. This phase can take as long as 10 minutes and the DSP1 shows the message "PUMP". If the display shows "FULL" it means that the water has to match water inside. Please empty the tank and place it again.

When the display shows the word "DEP", this means that the water was pumped and that the water tank can be removed.

Remove the water tank and dry it thoroughly. Let the cooking space cool down for a moment and then clean and dry it with a cloth or sponge. **The door should be left open for some time so that the appliance can dry completely.**

## 10.3 Secondary menu

This appliance also has a concealed "secondary menu" allowing the user to:

1. Activate or deactivate the Show Room function (which disables all the heating elements so that only the control panel works);
2. Perform a Descale cycle;
3. Change the Water Hardness Level
4. Activate or deactivate the child safety device ();

### 10.3.1 Show Room Function

With the oven in OFF status (see point "8.2 Operating settings") keep PT1 pressed until the message OFF SHO appears on DSP1 and DSP2. This means that the SHOW ROOM function (which disables all the heating elements so that only the control panel works) is not active.

Turn PT1 to the right or left to activate (ON SHO) or deactivate (OFF SHO) this function. To use the oven normally, set OFF SHO.

After setting the parameter required, press PT2 to return the oven to the initial standby status.





## 10.3.2 Descale function

**Warning: For safety reasons, the descaling process cannot be interrupted and it takes about 45 minutes.**

The appliance can be descaled with the appliance door open or closed. (See 11.1)

To run a descaling cycle proceed as follows:

With the oven in OFF status (see point "8.2 Operating settings") keep PT1 pressed until the message OFF SHO appears on DSP1. Now press PT1 until the message "ENTR CAL" appears on DPS1 and DSP2.

Turn PT1 to the right press PT2 at the same time to activate the descale program . When this function is active, the  symbol appears on DPS2.

When the display shows "**0.5L**", remove the water tank.

Pour 0,5 litres of an adequate descaling solution into the water tank and put the water tank back (see 11.2).

Press PT2 to start the Descale cycle that takes about 30 minutes.

When the display shows "**1.0L**" flashing and the oven emits a beep, remove and empty the water tank.

Fill the water tank with 1,0 litres of cold water and put the water tank back.

Press PT2 to start the first rinsing cycle.

When the display again shows "**1.0L**" flashing and the oven emits a new beep, remove and empty the water tank.

Fill the water tank with 1,0 litres of cold water and put the water tank back.

Press PT2 to start the second rinsing cycle.

When the rinsing cycle has finished the display shows "**End**".

Remove, empty and dry the water tank.

## 10.3.3 Changing the water hardness level

With the oven in OFF status (see point "8.2 Operating settings") keep PT1 pressed until the message OFF SHO appears on DSP1. Now press PT1 until the message "MED DUR" appears on DPS1 and DSP2.

Turn PT1 to the right or left to change the hardness level. Available options are HARD, MED and SOFT.

After setting the parameter required, press PT2 to return the oven to the initial standby status.



### **10.3.4 Child safety lock-out function**

With the oven in OFF status (see point “8.2 Operating settings”) keep PT1 pressed until the message OFF SHO appears on DSP1. Now press PT1 until the message “OFF BLOC” appears on DPS1.

Turn PT1 to the right or left to activate (ON BLOC) or deactivate (OFF BLOC) this function, which locks out all the functions and knobs after 3 minutes of operation without any command from the user (when this system is active, the  symbol appears on DPS2).

After setting the parameter required, press PT2 to return the oven to the initial standby status.

To exit the lockout status temporarily to modify a cooking program or select a different function, keep PT1 pressed until the  symbol disappears from DSP2. The required changes can now be made, and 2 minutes after the last setting is made the lockout will come into operation again.

To deactivate the lockout permanently, access the secondary menu and switch the function off as described in this section.



# Instructions for the User

EN

## 10.4 Display messages

DISPLAY	DESCRIPTION
<b>DESCALING</b>	
<b>SOFT</b>	SOFT WATER.
<b>MED</b>	MEDIUM WATER.
<b>HARD</b>	HARD WATER.
<b>CAL</b>	APPLIANCE MUST BE DESCALED. FLASHING – DESCALING STARTS.
<b>0.5L</b>	FEED 0.5 LITRE DESCALING SOLUTION INTO THE WATER TANK.
<b>1.0L</b>	FEED 1 LITRE COLD WATER INTO THE WATER TANK FOR RINSING.
<b>WATER TANK</b>	
<b>RES</b> <b>REP</b>	INDICATION THAT WATER TANK IS MISSING OR WRONGLY INSERTED THE WATER TANK MUST BE REMOVED, EMPTIED AND REINSERTED.
<b>STEAM REDUCTION AND WATER PUMPING</b>	
<b>VRP</b>	INDICATION THAT STEAM REDUCTION PROCESS IS ONGOING.
<b>PUMP</b>	INDICATION THAT COLD WATER IS ENTERING THE BOILER AND HOT WATER IS BEING PUMPED TO THE WATER TANK.
<b>FULL</b>	THE WATER TANK MUST BE REMOVED, EMPTIED AND REINSERTED.
	PERFORM WATER LEVEL CALIBRATION ( SEE 8.3.2)
<b>SYSTEM WARNINGS</b>	
<b>HOT</b>	TEMPERATURE IN THE PCB IS TOO HIGH.
<b>SYMBOLS</b>	
	CHILD SAFETY LOCK-OUT FUNCTION
	DESCALE FUNCTION
	WATER LEVEL INDICATION
	TEMPERATURE

## 10.5 Cooling fan system

The appliance is equipped with a cooling system which comes into operation as soon as a cooking function starts.

**Operation of the fans generates a normal air flow which comes out above the door and may continue for a short time even after the oven is switched off.**

## 10.6 Inside light

The oven light comes on:

- when the oven door is opened in standby status (point “8.2 Operating settings”) or;
- when the function knob is turned to any function.

If the oven door is left open, the oven light will automatically shut-off after 10 minutes.



## 11 RECOMMENDED COOKING TABLES

For more detailed information about cooking refer to the following tables. The suggested times and temperatures are guideline values. The actual cooking time can vary according to the type and quality of the foods. The levels indicated in the last column of the tables are explained in the following picture.

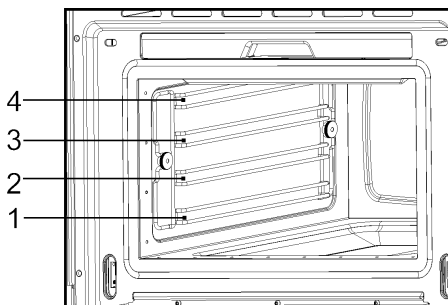

The perforated container with the food should preferably be inserted into the level 2. In this case it is important that the non-perforated container is introduced into the level 1. This way, dripping liquids are collected and the appliance does not get dirty.

To remove the rack, lift it upwards slightly at the front when the safety notches connect with the sides of the oven (see illustration).

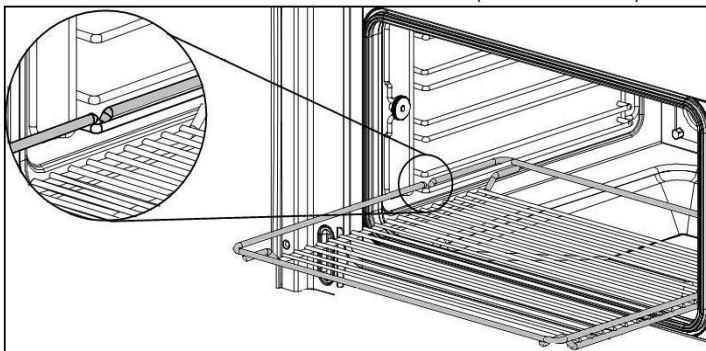

We recommend using the rack together with the baking tray when cooking items on the rack which might drip.



# Instructions for the User

EN

## 11.1 Fish

FISH	QUANTITY	TEMPERATURE (°C)	TIME (MIN.)	CONTAINER	LEVEL
GILTHEAD SEA BREAM	800-1200 G	80	30-40	PERFORATED	2
TROUT	4 X 250 G	80	20-25	PERFORATED	2
SALMON FILET	500-1000 G	80	15-25	PERFORATED	2
SALMON TROUT	1000-1200 G	80	25-35	PERFORATED	1/2
KING PRAWNS	500-1000 G	80	15-20	PERFORATED	2
GREEN-SHELL MUSSEL	1000-1500 G	100	25-35	PERFORATED	2
HALIBUT FILET	500-1000 G	80	20-25	PERFORATED	2
COCKLES	500-1000 G	100	10-20	PERFORATED	2
LOBSTER	800-1200 G	100	25-30	PERFORATED	1/2
COD FILET	1000-1200 G	80	20-25	PERFORATED	2
BLUE MUSSEL	1000-1200 G	100	15-25	PERFORATED	2
LAKE TROUT	4 X 250 G	80	25-30	PERFORATED	2
HADDOCK	1000-1200 G	80	20-25	PERFORATED	2
TUNA FILET	500-1000 G	80	15-20	PERFORATED	2
PIKE PERCH	4 X 250 G	80	25-30	PERFORATED	2



### 11.2 Meat

MEAT	QUANTITY	TEMPERATURE (°C)	TIME (MIN.)	CONTAINER	LEVEL
CHICKEN LEG	4-10	100	40-45	PERFORATED	2
CHICKEN BREAST	4-6	100	25-35	PERFORATED	2
SMOKED PORK LOIN	500G – 1000 G	100	40-50	PERFORATED	2
TURKEY ESCALOPE	4-8	100	20-25	PERFORATED	2
PORK FILET, WHOLE	4-8	100	20-30	PERFORATED	2
SAUSAGES		80-100	10-15	PERFORATED	2

### 11.3 Eggs

EGGS	TEMPERATURE (°C)	TIME (MIN.)	CONTAINER	LEVEL
EGGS IN GLASS	100	10-15	RACK	2
EGGS, HARD	100	15	RACK	2
EGGS, SOFT	100	10-12	RACK	2

### 11.4 Side dishes

SIDE DISHES	QUANTITY	TEMPERATURE (°C)	TIME (MIN.)	CONTAINER	LEVEL
PEARL BARLEY + LIQUID	200G + 400 ML	100	30-35	RACK,	2
SEMOLINA + LIQUID	200G + 300 ML	100	10-20	RACK	2
LENTILS + LIQUID	200G + 375 ML	100	20-50	RACK	2
RICE + LIQUID	200G + 250 ML	100	25-40	RACK	2



# Instructions for the User

EN

## 11.5 Vegetables

VEGETABLES		TEMPERATURE (°C)	TIME (MIN.)	CONTAINER	LEVEL
EGGPLANT/AUBERGINE	IN SLICES	100	15-20	PERFORATED	2
BEANS		100	35-45	PERFORATED	2
BROCCOLI	FLORETS WITH STALK	100	25-30	PERFORATED	2
BROCCOLI	FLORETS WITHOUT STALK	100	15-20	PERFORATED	2
CAULIFLOWER	FLORETS	100	25-30	PERFORATED	2
CAULIFLOWER	WHOLE HEAD	100	40-45	PERFORATED	1
PEAS		100	30-35	PERFORATED	2
FENNEL	IN STRIPES	100	15-20	PERFORATED	2
FENNEL	CUT IN HALF	100	20-30	PERFORATED	2
POTATOES WITH SKIN	WHOLE, VERY SMALL	100	20-25	PERFORATED	2
POTATOES WITH SKIN	WHOLE, VERY BIG	100	45-50	PERFORATED	2
POTATOES WITHOUT SKIN	IN PIECES	100	20-25	PERFORATED	2
TURNIP	IN STICKS	100	20-25	PERFORATED	2
SNOW PEAS		100	15-20	PERFORATED	2
CARROTS	IN SLICES	100	25-30	PERFORATED	2
CORN COBS		100	50-60	PERFORATED	2
BELL PEPPERS	IN STRIPES	100	12-15	PERFORATED	2
HOT PEPPER		100	12-15	PERFORATED	2
MUSHROOMS	IN QUARTERS	100	12-15	PERFORATED	2
LEEKs	IN SLICES	100	10-12	PERFORATED	2
BRUSSELS SPROUTS		100	25-35	PERFORATED	2
CELERY	IN STRIPES	100	15-20	PERFORATED	2
ASPARAGUS		100	20-35	PERFORATED	2
SPINACH		100	12-15	PERFORATED	2
CELERY STALKS		100	25-30	PERFORATED	2
COURGETTE	IN SLICES	100	12-18	PERFORATED	2



### 11.6 Dumplings

DUMPLINGS	TEMPERATURE (°C)	TIME (MIN.)	CONTAINER	LEVEL
SWEET DUMPLING	100	20-30	NOT PERFORATED	2
SWEET YEAST DUMPLING	100	15-20	NOT PERFORATED	2
YEAST DUMPLING	100	15-25	NOT PERFORATED	2
BREAD DUMPLING	100	20-25	NOT PERFORATED	2
NAPKIN DUMPLING	100	25-30	NOT PERFORATED	2

### 11.7 Desserts

DESSERTS	QUANTITY	TEMPERATURE (°C)	TIME (MIN.)	CONTAINER	LEVEL
STEWED APPLES	500-1500 G	100	15-25	NOT PERFORATED	2
STEWED PEARS	500-1500 G	100	25-30	NOT PERFORATED	2
CRÈME BRÛLÉE		80	20-25	RACK	2
CRÈME CARAMEL		80	25-30	RACK	2
YOGURT		40	4-6 HRS.	RACK	2
STEWED PEACHES	500-1500 G	100	15-20	NOT PERFORATED	2

### 11.8 Fruit (Sterilising / Boiling down)

FRUIT	QUANTITY	TEMPERATURE (°C)	TIME (MIN.)	CONTAINER	LEVEL
PEARS	4-6 1L GLASSES	100	30-35	RACK	1
CHERRIES	4-6 1L GLASSES	80	30-35	RACK	1
PEACHES	4-6 1L GLASSES	80	30-35	RACK	1
PLUMS	4-6 1L GLASSES	80	30-35	RACK	1

### 11.9 Regenerate

WARMING-UP	QUANTITY	TEMPERATURE (°C)	TIME (MIN.)	CONTAINER	LEVEL
PLATE DISHES	1-2	100	12-15	RACK	2
PLATE DISHES	3-4	100	15-20	RACK	2
READY-MADE MEALS		100	15-20	RACK	2

### 11.10 Blanch

VEGETABLES	QUANTITY	TEMPERATURE (°C)	TIME (MIN.)	CONTAINER	LEVEL
E.G. BEANS, LEEK		100	10-12	PERFORATED	2
CURLY KALE	1000-2000 G	100	12-16	PERFORATED	2
SAVOY CABBAGE	10-20	100	12-15	PERFORATED	2
WHITE CABBAGE, WHOLE	2000-2500 G	100	30-45	PERFORATED	1
TOMATOES, PEELED		80	12	RACK	2



# Instructions for the User

EN

## 11.11 Defrost

VEGETABLES / SIDE DISH		TEMPERATURE (°C)	TIME (MIN.)	CONTAINER	LEVEL
BROCCOLI	FLORETS WITH STALK	40	15-20	PERFORATED	2
MIXED VEGETABLES		40	15-20	PERFORATED	2
SPINACH LEAVES	PORTIONS	40	10-15	NOT PERFORATED	2
CAULIFLOWER	FLORETS	40	15-20	PERFORATED	2
PEAS		40	15-25	PERFORATED	2
CURLY KALE	BIGGER PORTION	40	25-35	NOT PERFORATED	2
CARROTS	IN SLICES	40	15-20	PERFORATED	2
BRUSSELS SPROUTS		40	20-25	PERFORATED	2
ASPARAGU		40	25-30	PERFORATED	2
READY-MADE MEALS		40	AS REQUIRED	RACK	2
BREAD		40	10-25	RACK	2
RICE		40	15-25	NOT PERFORATED	2
LENTILS		40	15-20	NOT PERFORATED	2
NOODLES		40	15-20	NOT PERFORATED	2

## 11.12 Two level cooking

### Some suggestions:

When cooking with two levels the accessories should be always inserted in the 2nd or 3rd level and in the 1st level.

Different cooking times are controlled this way:

Foods that need a longer cooking time should be placed in the upper area of the oven. Foods with a shorter cooking time should be placed on the 1st level.

**One example:** Vegetables, potatoes and fish.

Place the vegetables and potatoes in any suitable container on the rack inserted in the 2nd or 3rd level.

Insert the fish in the 1st level.

When using the perforated tray to cook fish, the non-perforated tray must be inserted in the bottom of the appliance to collect liquid dripping from the fish. This way the appliance is kept clean.

Time: Vegetables and potatoes 25-35 Min.

Time: Fish – depending on type – 15-25 Min.

Select the longest cooking time. Because of the different levels the food is ready at the same time, without any over cooking.



## 12 CARE AND MAINTENANCE

### 12.1 Descaling

Whenever steam is produced, irrespective of the hardness of the local water supply (i.e. the limescale content of the water), limescale is deposited inside the steam generator.

The time interval between descaling depends on the hardness of the water and frequency of use. If steaming 4x30 minutes per week, the appliance must be descaled (depending on water hardness) roughly as follows:

WATER HARDNESS	LEVEL NO.	DESCALE AFTER ABOUT
VERY SOFT	<i>SOFT</i>	18 MONTHS
MEDIUM	<i>MED</i>	9 MONTHS
VERY HARD	<i>HARD</i>	6 MONTHS

The appliance automatically detects when descaling is necessary and when this happens the Descal light turn on. If the Descaling procedure is not performed, some cooking cycles after the Descal light starts to flash. If once again the Descaling procedure is not performed, some cooking cycles after the oven functioning is blocked, the Descal light stays on and the display shows “CAL” blinking. The oven keep being blocked until the descale procedure is performed

**To run a descale cycle proceed as described in 10.3.2 Descal function.**

**IMPORTANT NOTE: Failure to descale the appliance will likely impair the functioning of or cause damage to the appliance.**

### 12.2 Suitable descaling solutions

For descaling use suitable solution, as Durgol or liquid coffee machine descaling solutions for example. Solutions containing foam agents are not appropriate.

**Warning! Do not use vinegar or vinegar-based products as they can cause damage to the oven’s internal circuit.**

### 12.3 Descaling Process

Please see point 10.3.2

### 12.4 Cleaning the oven

The steam oven cavity and front surface must be cleaned after each use. All food remains and condensed water must be removed (see section on Oven Cleaning). If the steam oven is not kept clean its surface may deteriorate **and this may shorten the oven’s working life.**

For ease of cleaning, the shelf guides can be removed (see the following chapter).

**IMPORTANT NOTE: Don’t wash the water tank in the dishwasher machine.**



# Instructions for the User

EN

## 12.5 Removing the shelf guides

1. Unscrew and remove the knurled nuts 1 in the front of the shelf guides in an anti-clockwise direction.

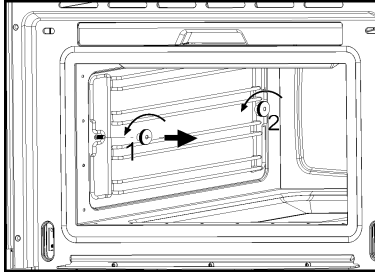

2. Unscrew and loosen the knurled nuts 2 in the back of the shelf guides in an anti-clockwise direction. Do not completely remove these nuts.

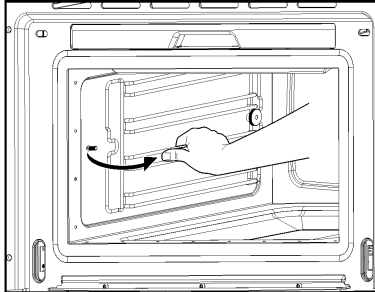

3. Pull the shelf guides to the inside of the cavity and remove from the front.

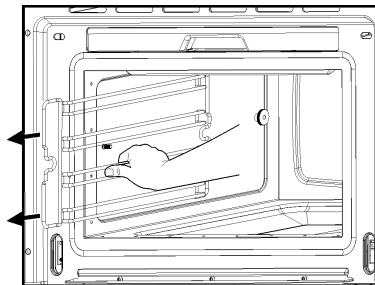

To put them back, insert the shelf guides into the knurled nuts 2 in the back and position on the screws in the front.

Screw the knurled nuts 1 and 2 in a clockwise direction till tight.



### 12.6 Removing the appliance door

1. Open the appliance door as far as it will go.

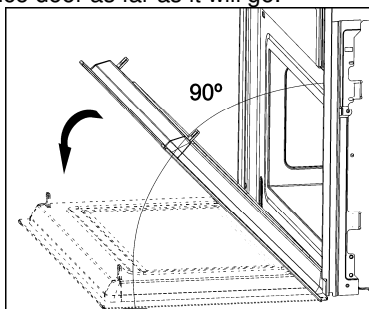

2. Insert 2 pins inside the holes in the hinges.

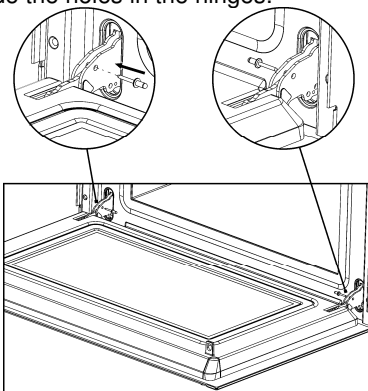

3. Close the appliance door just enough that it can be lifted out.

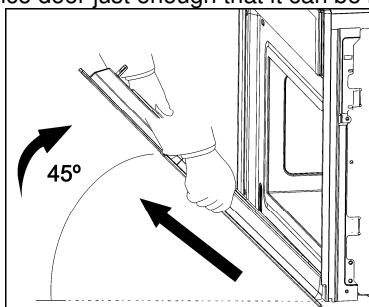

4. To reassemble, push the hinges into the holes from the front.
5. Open the appliance door as far as it will go and remove the pins.



## 13 OVEN CLEANING



**Warning!** Cleaning should be done with the oven power switched off. Take the plug out of the socket or switch off the oven's power circuit.



**Warning!** Do not use aggressive or abrasive cleaning products, scourers that scratch surfaces or sharp objects, since stains may appear. To clean stainless steel parts, please use suitable detergent which does not contain abrasive or acid substances or chlorine.



**Warning!** Never use high pressure or steam jet cleaning appliances.

### 13.1 Front surface

Normally you just need to clean the oven with a damp cloth. If it is very dirty, add a few drops of dishwashing liquid to the cleaning water. Afterwards, wipe the oven with a dry cloth.

**In an oven with a finger print proof treatment front**, use a mild glass cleaning product and a soft cloth that does not release any fibres or threads. Wipe from side to side without exerting any pressure on the surface.

Immediately remove limescale, fat, starch or egg white stains. Corrosion can occur under these stains.

Do not let any water get inside the oven.

### 13.2 Oven interior

After use, remove any water on the bottom of the cooking space with a soft cloth. Leave the appliance door open so that the cooking space can cool down.

To remove dirt that is harder to shift, use a non-aggressive cleaning product. **Do not use oven sprays or other aggressive or abrasive cleaning products.**

**Always keep the door and the oven front very clean to ensure that the door opens and closes properly.**

Make sure water does not enter the oven ventilation holes.

The glass lamp cover is located on the oven ceiling and can be removed easily for cleaning. For this you just need to unscrew it and clean it with water and dishwashing liquid.

### 13.3 Accessories

Clean the accessories after each use. If they are very dirty, soak them first of all and then use a brush and sponge. The accessories can be washed in a dish washing machine except the water tank.



## 14 EXTRAORDINARY MAINTENANCE

Occasionally, the oven will require minor servicing procedures or the replacement of parts subject to wear and tear, such as gaskets, light bulbs, etc. The specific operations for each procedure of this kind are provided below.

*Before carrying out any operation involving access to live parts, disconnect the appliance from the electricity supply.*



### 14.1 What should I do if the oven doesn't work?

**WARNING!** Any type of repair must only be done by a specialised technician. Any repair done by a person not authorised by the manufacturer is dangerous.

You do not need to contact Technical Assistance to resolve the following questions.

<b>Failure description</b>	<b>Solution</b>
<i>The display is not showing!</i>	- The time indication has been switched off (see section on Operating Settings).
<i>Nothing happens when I press the keys!</i>	- The Safety Block is active (see section on Child Safety Lock-out function).
<i>The oven does not work!</i>	- Check if the plug is correctly fitted in the socket. - Check if the oven power is switched on.
<i>When the oven is operating I can hear some strange noises!</i>	- It has to do with the operating noises that can occur during the cooking process, e.g. by the water pumps in the steam generator. - The steam inside the cavity produces a pressure build-up and sometimes the cavity walls may produce noise when they react to the pressure. - These noises are normal, there is no problem.
<i>The food doesn't heat up or heats very slowly!</i>	- You have selected the correct operating times and temperature setting. - The food you have put inside the oven is a larger amount or colder than you usually put in.
<i>The message "Err_" appears in the display</i>	- Please contact the Customer Care.
<i>The appliance still makes a noise after the cooking process is finished!</i>	This is not a problem. The cooling fan keeps on working for some time. When the temperature has dropped sufficiently, the fan will switch itself off.
<i>The oven switches on but the interior light does not go on!</i>	If all the functions work properly it is probable that the lamp has blown. You can keep on using the oven.
<i>Display shows </i>	Perform water level calibration (see 8.3.2)



## 14.2 Replacing the light bulb

**WARNING:** Ensure that the appliance is switched off before replacing the lamp to avoid the possibility of electric shock.

To replace the light bulb, proceed as follows:

- Disconnect the oven from the power supply. Take the plug out of the socket or switch off the oven's power circuit.
- Unscrew and remove the glass light cover (1).
- Remove the light bulb (2). Warning! The bulb may be very hot.
- Fit a new E14 230-240V/15W bulb. Follow the lamp manufacturer's instructions. **IMPORTANT NOTE:** Make sure that the sealing rings (3) are applied in the correct sequence.
- Screw the glass light cover into place (1).
- Connect the oven again to the power supply.

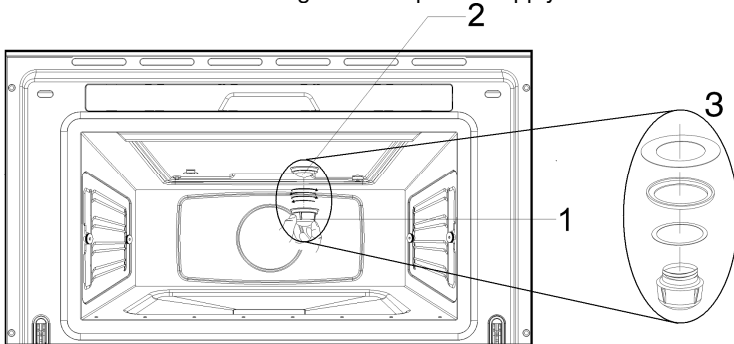



## 15 INSTALLING THE APPLIANCE

### 15.1 Before installation

**Check that the input voltage** indicated on the characteristics plate is the same as the voltage of the power outlet you are going to use.

Open the oven door and **take out all the accessories** and remove the packing material.

**Warning!** The front surface of the oven may be covered in a **protective film**. Before using the oven for the first time, carefully remove this film, starting on the inside.

**Make sure that the oven is not damaged in any way.** Check that the oven door closes correctly and that the interior of the door and the front of the oven opening are not damaged.

**DO NOT USE THE OVEN** if the power cable or the plug is damaged, if the oven does not function correctly or if it has been damaged or dropped.

Put the oven on a flat and stable surface. The oven must not be installed close to any sources of heat, radios or televisions.

**During installation, make sure that the power cable does not come into contact with any moisture or objects with sharp edges and the back of the oven. High temperatures can damage the cable.**

**Warning: after the oven is installed you must make sure you can access the plug.**

### 15.2 Electrical connection



The nameplate with the technical data, serial number and mark is in a visible position on the oven door frame.

The nameplate must never be removed.



The appliance must be connected to earth in compliance with electrical system safety regulations.



If a permanent connection is used, the appliance's power supply line must be fitted with an omnipolar breaking device with contact gap of at least **3 mm**, located in an easily accessible position close to the appliance itself.



If a socket and plug connection is used, check that they are of the same type. Do not use reducers, adapters or junctions since they may cause overheating or burns.



## 15.3 Positioning the oven

The appliance is designed for building-in to cabinets made from any heat-resistant material. Comply with the dimensions shown in following pictures. When installing in tall units bear in mind that the top/rear of the unit must have an opening 100 mm deep.

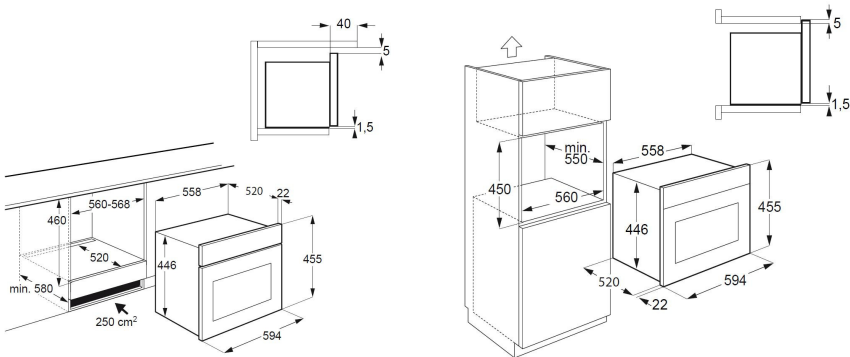

Screw the 4 screws into the inside of the frame.

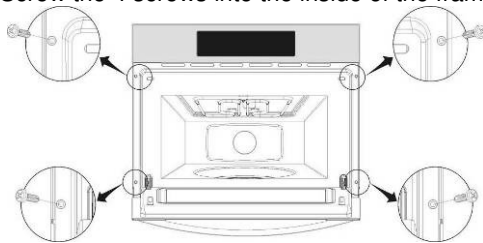

The manufacturer reserves the right to make any changes deemed useful for improvement of his products without prior notice. The illustrations and description contained in this manual are therefore not binding and are merely indicative