

5.25 MOTORIZED TREADMILL

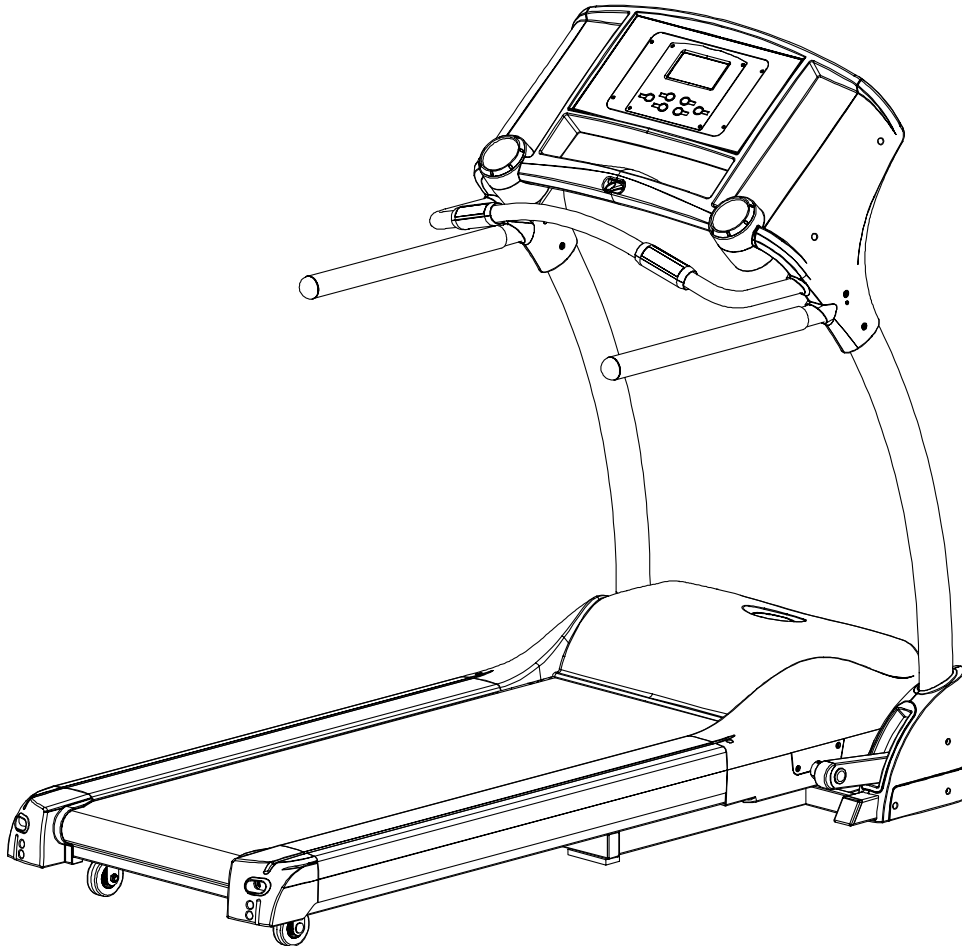

USER WEIGHT LIMITATION: **275lbs. (124 kgs.)**

SERIAL NUMBER (found on frame):

PRECAUTIONS

For future service or related questions:

Please staple your receipt and/or write in the name and phone number of the retail store where you purchased your treadmill.

Name: _____ Phone Number: _____ Receipt: _____

Precautions:

WARNING: To reduce the risk of burns, fire, electric shock, or injury to persons, read the following important precautions and information before operating the treadmill. It is the responsibility of the owner to ensure that all users of this treadmill are adequately informed of all warnings and precautions.

- Use the treadmill only as described in this manual.
- Place on a level surface, with 6 feet (2 m) of clearance behind it. Do not place the treadmill on any surface that blocks air openings. To protect the floor or carpet from damage, place a mat under the treadmill.
- When choosing a location for the treadmill be sure that the location and position permit access to a plug.
- Keep the treadmill indoors, away from moisture and dust. Do not put the treadmill in a garage or covered patio, or near water.
- Do not operate the treadmill where aerosol products are used or where oxygen is being administered.
- Keep children under the age of 12 and pets away from the treadmill at all times.
- The treadmill should not be used by persons weighing more than **275lbs (124 kgs.)**
- Never allow more than one person on the treadmill at a time. Wear appropriate exercise clothing when using the treadmill. Do not wear loose clothing that could become caught in the treadmill. Athletic support clothes are recommended for both men and women. Always wear athletic shoes. Never use the treadmill with bare feet, wearing only stockings, or in sandals.
- When connecting the power cord, plug the power cord into a grounded circuit. No other appliance should be on the same circuit.
- Always straddle the belt and allow it to start moving before stepping onto the belt.
- Always examine your treadmill before using to ensure all parts are in working order.
- Allow the belt to fully stop before dismounting.
- Never insert any object or body parts into any opening.
- Follow the safety information in regards to plugging in your treadmill.
- Keep the power cord away from the incline wheels and do not run the power cord underneath your treadmill. Do not operate the treadmill with a damaged or frayed power cord.
- Always unplug the treadmill before cleaning and/or servicing. Service to your treadmill should only be performed by an authorized service representative, unless authorized and/or instructed by the manufacturer. Failure to follow these instructions will void the treadmill warranty.
- Never leave the treadmill unattended while it is running.
- This equipment is Class B (Home Use Only).

POWER REQUIREMENTS

Power Requirements:

IMPROPER CONNECTION OF THE EQUIPMENT GROUNDING CONNECTOR CAN RESULT IN THE RISK OF AN ELECTRIC SHOCK. CHECK WITH A QUALIFIED ELECTRICIAN OR SERVICE MAN IF YOU ARE IN DOUBT AS TO WHETHER THE PRODUCT IS PROPERLY GROUNDED. DO NOT MODIFY THE PLUG PROVIDED WITH THE PRODUCT, IF IT WILL NOT FIT THE OUTLET; HAVE A PROPER OUTLET INSTALLED BY A QUALIFIED ELECTRICIAN.

This treadmill can be seriously damaged by sudden voltage changes in your home's electrical power. Voltage spikes, surges and noise interference can result from weather conditions or from other appliances being turned on or off. To reduce the possibility of treadmill damage, always use a surge protector (not included) with your treadmill.

Surge protectors can be purchased at most hardware stores. The manufacturer recommends a single outlet surge protector with a UL 1449 rating as a Transient Voltage Surge Suppressor (TVSS) with a UL suppressed voltage rating of 400V or less and an electrical rating 110VAC, 15 amps.

This treadmill must be grounded to reduce the risk of electrical shock. Grounding provides a path of least resistance for electric current, should the treadmill malfunction. This treadmill is equipped with an electrical cord that has an equipment-grounding conductor and a grounding plug. Always plug the power cord into a surge protector, and plug the surge protector into an appropriate outlet that is properly installed and grounded in accordance with all local codes and ordinances.

This product is for use on a nominal 110-volt circuit, and has a grounding plug that looks like the plug illustrated in the drawing below. GFCI outlets and GFCI Circuit Breakers are NOT recommended for use on this product. GFCI outlets and GFCI Circuit Breakers may cause this equipment to improperly function.

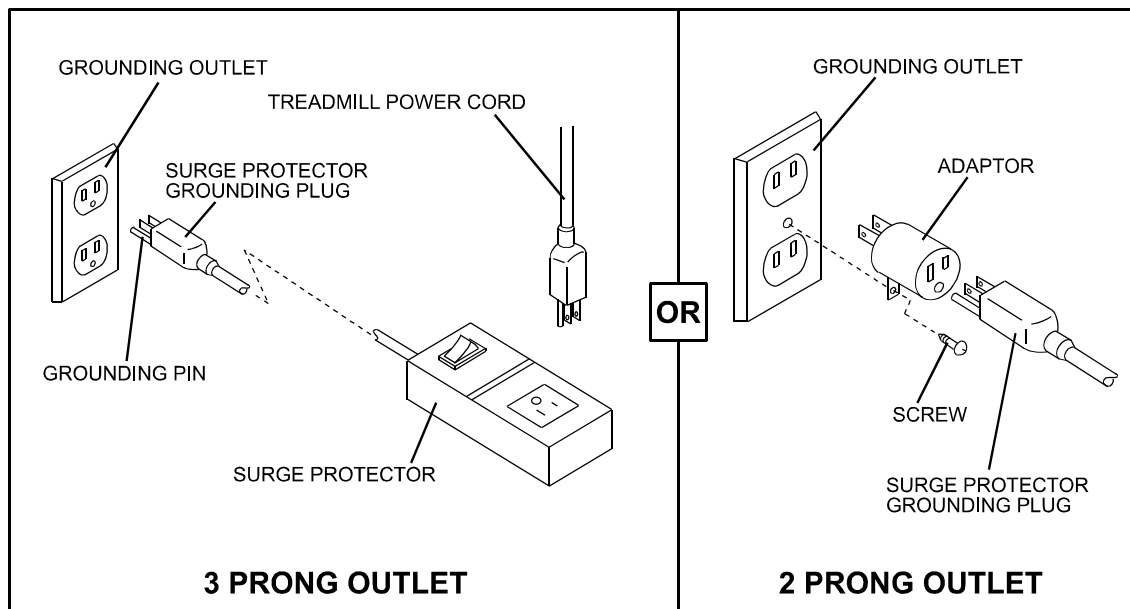

Before You Begin

- **Open the boxes:**

Open the boxes of your new equipment. Inventory all parts included in the boxes, and compare them to the Supplied Components and Supplied Hardware lists on pages 5-6 for a full count of the parts included. If you are missing any parts or have any questions contact us directly at 888-800-1167

*Assembly instructions begin on page 10.

- **Gather your tools:**

Before you begin, make sure that you have gathered all the necessary tools you may require to assemble the unit properly. Having all of the necessary equipment at hand will save time and make the assembly quick and hassle-free.

- **Clear your work area:**

Make sure that you have cleared away a large enough space to properly assemble the unit. Make sure the space is free from anything that may cause injury during assembly. After the unit is fully assembled, make sure there is a comfortable amount of free area around the unit for unobstructed operation.

- **Invite a friend:**

Some of the assembly steps may require heavy lifting. It is recommended that you obtain the assistance of another person when assembling this product.

- **User Weight Limitation:**

Please note that there is a weight limitation for this product. If you weigh more than 275LB (Approx. 124 Kg) it is not recommended that you use this product. Serious injury may occur if the user's weight exceeds the limit shown here. This product is not intended to support users whose weight exceeds this limit.

- **Care and maintenance:**

The safety level can be maintained only if it is examined for damage and wear.

Replace any defective components immediately and stop all use of the equipment until repaired.

Always take care when mounting the equipment. Straddle the equipment by placing your feet on the straddle rails. Dismount from the equipment only after all parts have stopped.

Always check the wear and tear components like pulley, belts, etc....To prevent injury.

There is an emergency stop, in the form of a SAFETY KEY, to prevent injury; you can stop the treadmill immediately by actuating the emergency stop for emergency dismount.

Supplied Components

This list identifies the major components you will use to assemble this product. Component A, B, and C are already partially assembled

No.	Description	Qt
A	Main Frame Assembly	1
B	Front handlebar	1
C	Side handle bar	2
108	Water Bottle Holder	2
207	Handle Bar Cover - LL	1
208	Handle Bar Cover - LR	1
209	Handle Bar Cover - RL	1
210	Handle Bar Cover - RR	1
302	Upright Base Cover - LL	1
303	Upright Base Cover - LR	1
304	Upright Base Cover - RL	1
305	Upright Base Cover - RR	1

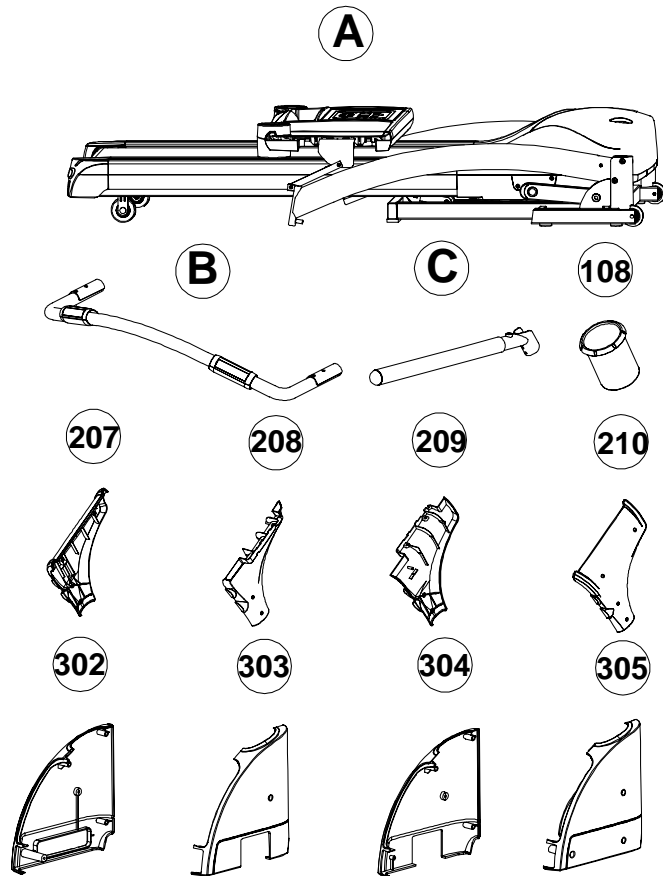

Supplied Hardware

This list identifies the hardware you will use to assemble the product. To help distinguish between the various types of screws and bolts, use the scale below to measure them and compare them to the sizes listed.

No.	Description	Qty.
802	M4x15 Screw	27
805	M8x45 Bolt	2
810	M8x18 Bolt	8
811	M8x52 Bolt	2
812	#8 Washer	12
845	M8x75 Bolt	2
A	Screw driver	1
B	Allen key	1
C	Allen Wrench	1
D	Safety Key	1
E	Power Cord	1

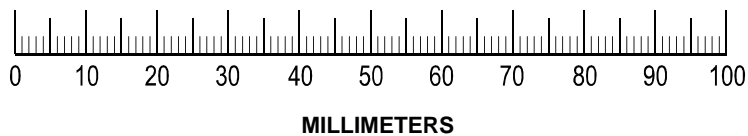
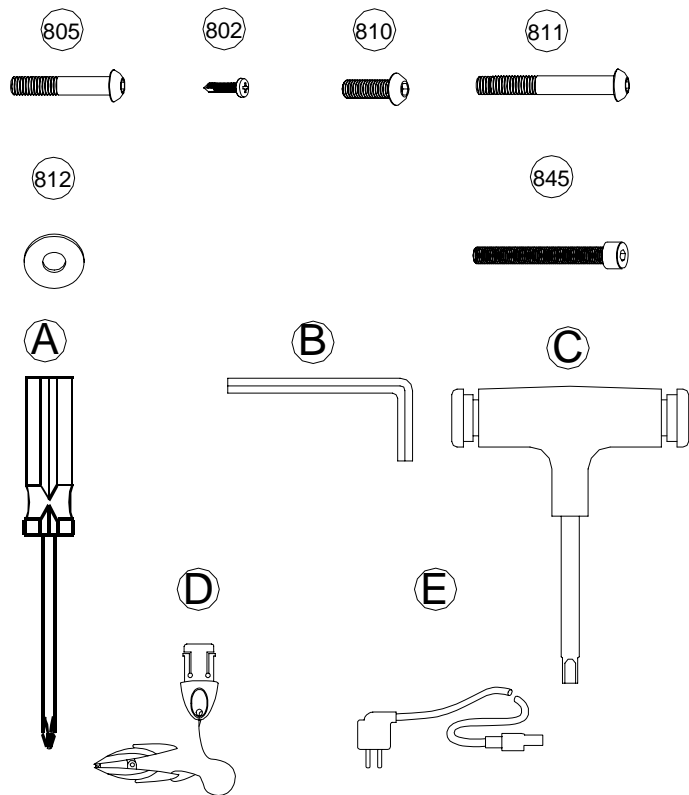

Complete Parts List

100 Complete Computer Console Components				
101	Overlay	1		5.25-101
102	Computer PC Board	1		5.25-102
103	Console Plate	1		5.25-103
104	Console Housing – Upper	1		5.25-104
105	Console Housing – Bottom	1		5.25-105
106	Safety Key Base	1		5.25-106
107	Safety Key	1		5.25-107
108	Water Bottle Holder	2		5.25-108
109	Hand Pulse Wire – Upper	2		5.25-109
110	Plastic Fixing Insert	8		5.25-110
111	Hand Pulse Wire – Lower	2		5.25-111
200 Complete Handle Bar Components				
201	Front Handle Bar Tube	1		5.25-201
202	Handle Bar	2		5.25-202
203	Handle Bar Upright Foam Grip	2		5.25-203
204	Handle Bar Upright Foam Grip	2		5.25-204
205	Handle Bar Upright Foam Grip	1		5.25-205
206	Hand Pulse Sensor	2		5.25-206
207	Handle Bar Cover – LL	1		5.25-207
208	Handle Bar Cover – LR	1		5.25-208
209	Handle Bar Cover – RL	1		5.25-209
210	Handle Bar Cover – RR	1		5.25-210
211	Console Connect Piece – L	1		5.25-211
212	Console Connect Piece – R	1		5.25-212
213	Console Connect Tube	2		5.25-213
216	Handle Bar End Cap	2		5.25-216
217	Hand Pulse Wire – Lower	2		5.25-217
300 Complete Upright Components				
301	Upright	2		5.25-301
302	Upright Low Cover – LL	1		5.25-302
303	Upright Low Cover – LR	1		5.25-303
304	Upright Low Cover – RL	1		5.25-304
305	Upright Low Cover – RR	1		5.25-305
306	Adjustable Cylinder Cover – Upper	2		5.25-306
307	Motion Control Sensor Wire – Middle	2		5.25-307
308	2 pin Safety Key Wire 2200 mm	1		5.25-308
309	7 pin Computer Wire – Upper 2980mm	1		5.25-309

COMPLETE PARTS LIST cont.

400		Complete Base Frame Components	
401	Base Frame	1	5.25-401
402	Rubber Cushion	2	5.25-402
403	Rubber Cushion	2	5.25-403
404	Power Switch Plate Base	1	5.25-404
405	Power Switch Plate Cover	1	5.25-405
406	Power Switch Plate	1	5.25-406
407	Power Breaker	1	5.25-407
408	Power Switch	1	5.25-408
409	Front Caster	2	5.25-409
410	Cushion	2	5.25-410
411	Foot Locker	1	5.25-411
412	Transportation Wheel Bracket	1	5.25-412
413	Spring	1	5.25-413
414	Transportation Wheel	1	5.25-414
415	Fold Up Locker	1	5.25-415
416	Spring Of The Fold Up Locker Assembly	1	5.25-416
500		Complete Motor Components	
501	Motor Hood Top	1	5.25-501
502	Driving Motor	1	5.25-502
503	Motor Holder	1	5.25-503
504	Driving Belt	1	5.25-504
505	Control Board	1	5.25-505
506	Elevation Support Tube	1	5.25-506
507	Elevation Support Tube End Cap	4	5.25-507
508	Elevation Motor	1	5.25-508
509	Elevation Gear Sleeve	1	5.25-509
510	Fold Up Support	1	5.25-510
511	Shock	1	5.25-511
512	Wheel	1	5.25-512
513	Plastic Clamp – Top	2	5.25-513
514	Plastic Clamp – Bottom	2	5.25-514
515	Elevation Support	2	5.25-515
516	Motor Hood – Left	1	5.25-516
517	Motor Hood – Right	1	5.25-517
518	Motor Bottom Cover	1	5.25-518
600.		Complete Running Deck Components	
601	Running Belt	1	5.25-601
602	Side Rail	2	5.25-602
603	Running Deck	1	5.25-603
604	Side Rail End Cap – Left	1	5.25-604
605	Side Rail End Cap – Right	1	5.25-605
606	Cushion Pad	8	5.25-606
607	Main Frame Cross Bar	1	5.25-607

COMPLETE PARTS LIST cont.

700	Complete Deck Frame Components		
701	Deck Frame	1	5.25-701
702	Front Roller Shaft	1	5.25-702
703	Front Roller Tube	1	5.25-703
704	Rear Roller Shaft	1	5.25-704
705	Rear Roller Tube	1	5.25-705
706	Running Deck Support Tube	2	5.25-706
707	Cushion Pad	6	5.25-707
800	Complete Hardware PACK		
801	M3.5x16 Screw	8	5.25-801
802	M4x15 Screw	49	5.25-802
803	M3x10 Screw	2	5.25-803
804	#4 Washer	4	5.25-804
805	M8x45 Bolt	2	5.25-805
806	M4x8 Screw	4	5.25-806
807	M5x30 Screw	4	5.25-807
808	M3x14 Screw	4	5.25-808
809	M8x49 Bolt	1	5.25-809
810	M8x18 Bolt	8	5.25-810
811	M8x52 Bolt	4	5.25-811
812	#8 Washer	22	5.25-812
813	M4x25 Screw	2	5.25-813
814	Transportation Wheel Bolt	3	5.25-814
815	#5 Washer	3	5.25-815
816	M5x10 Screw	3	5.25-816
817	M4x14 Screw	3	5.25-817
818	M10 Nylon Nut	7	5.25-818
819	M10x67 Bolt	2	5.25-819
820	14x50 Bolt	2	5.25-820
821	33x8x10 Screw	2	5.25-821
823	4x45 Screw	2	5.25-823
824	M10x116 Screw	1	5.25-824
825	#8 Nylon Nut	2	5.25-825
826	M8x12 Bolt	2	5.25-826
827	#8 Washer	2	5.25-827
828	#10 Washer	4	5.25-828
829	14 Clip	2	5.25-829

PARTS DIAGRAM

MOST OF THE PARTS SHOWN HERE HAVE ALREADY BEEN PRE-ASSEMBLED.

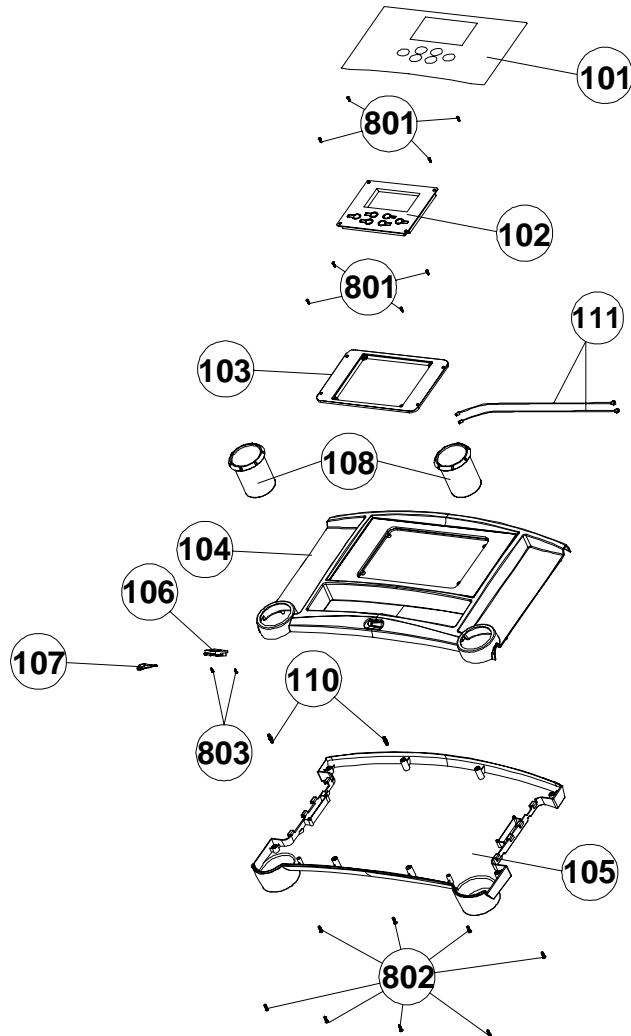
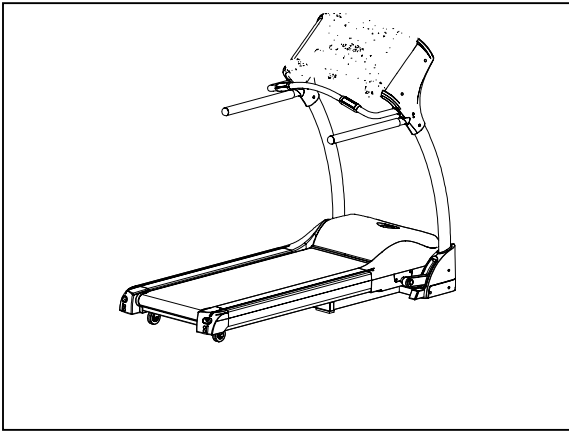

PARTS DIAGRAM

MOST OF THE PARTS SHOWN HERE HAVE ALREADY BEEN PRE-ASSEMBLED.

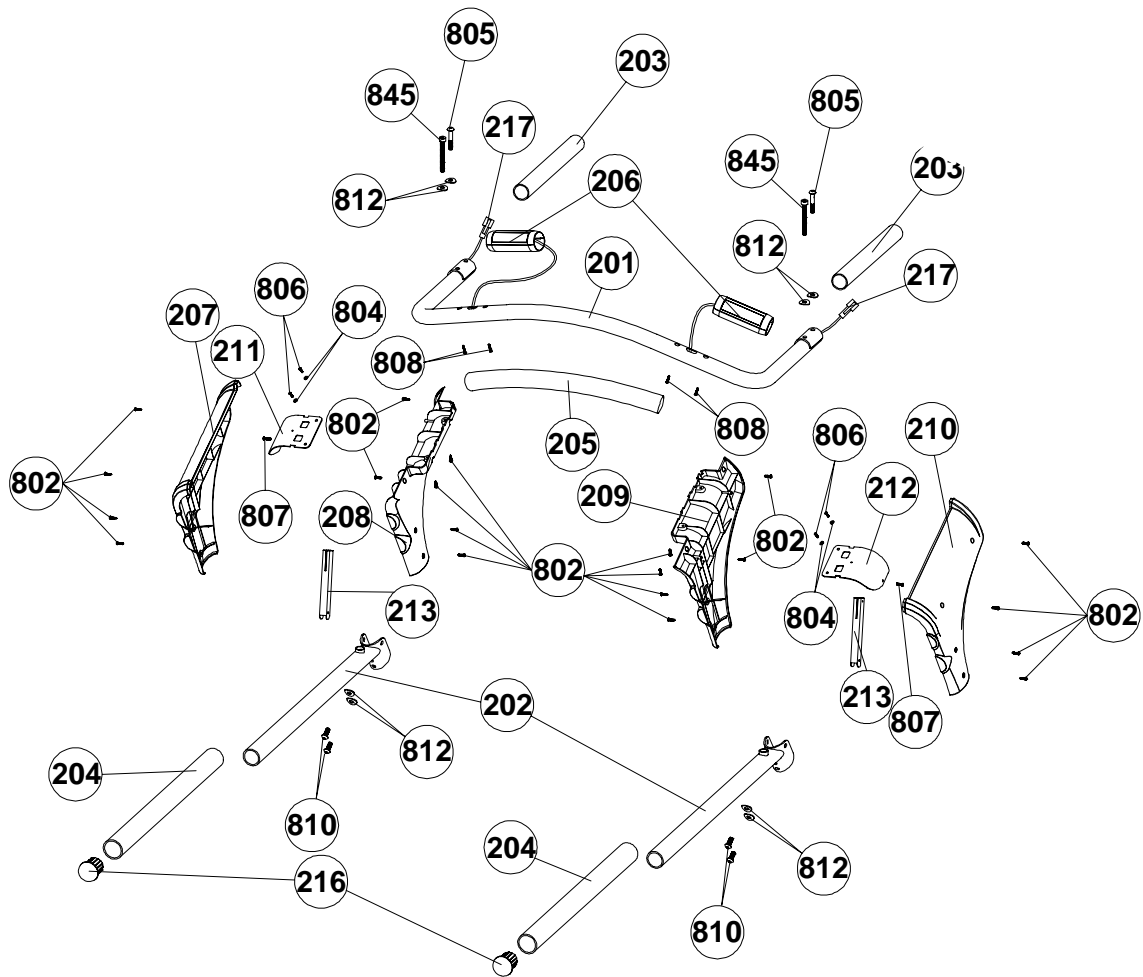
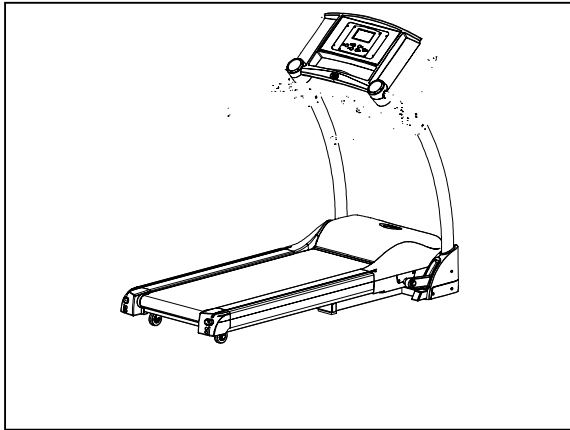

PARTS DIAGRAM

MOST OF THE PARTS SHOWN HERE HAVE ALREADY BEEN PRE-ASSEMBLED.

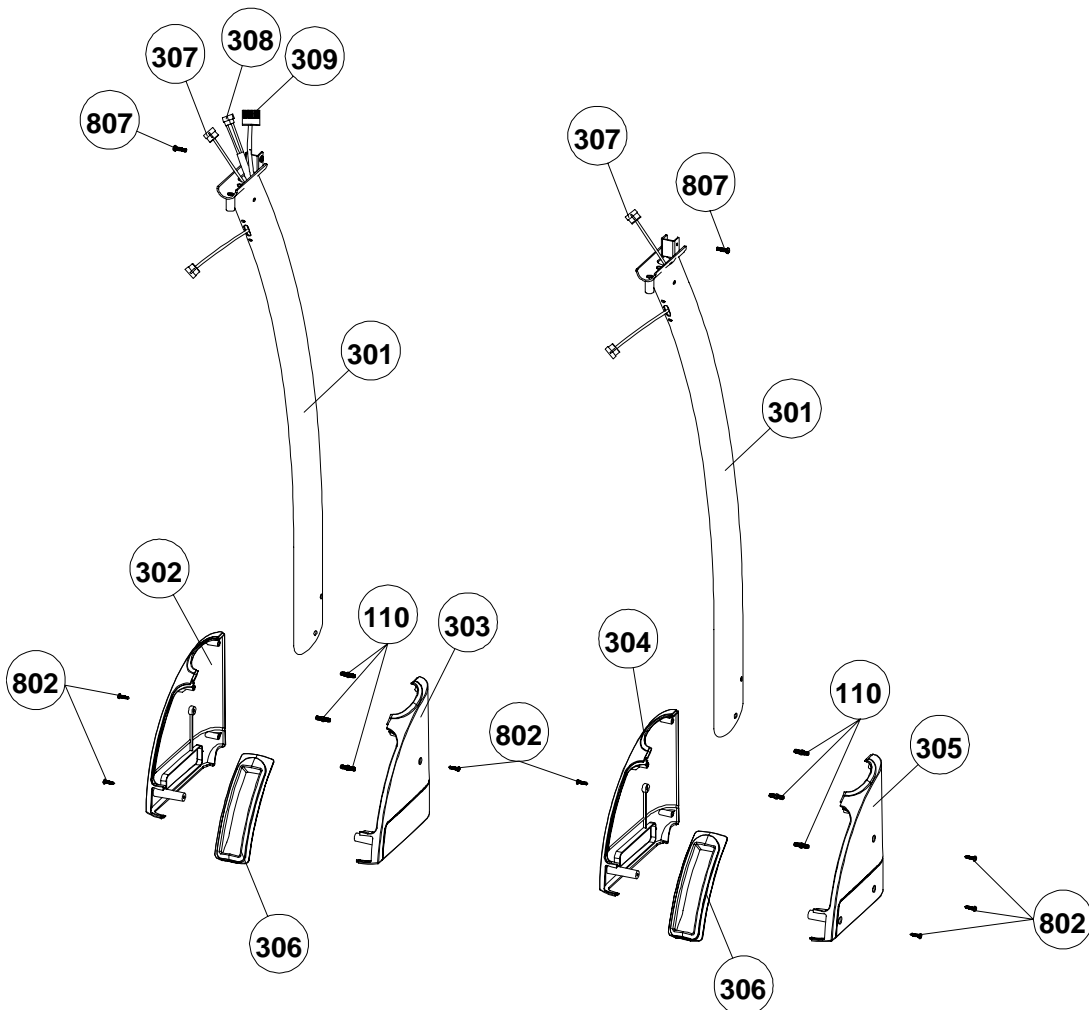
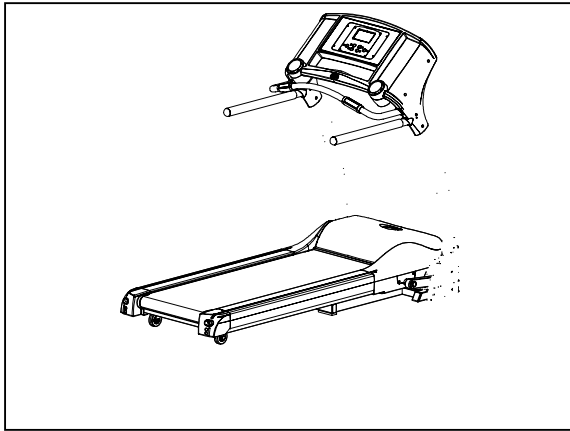

PARTS DIAGRAM

MOST OF THE PARTS SHOWN HERE HAVE ALREADY BEEN PRE-ASSEMBLED.

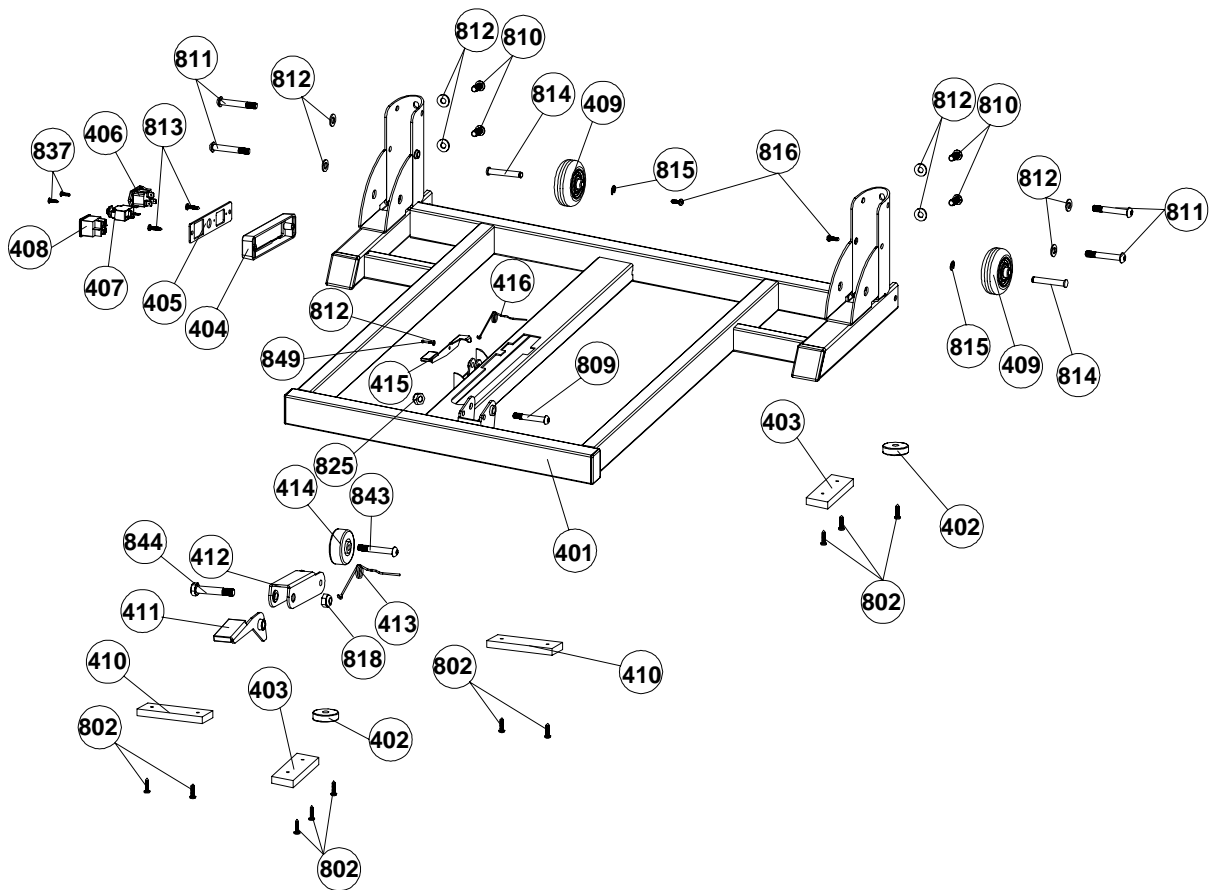
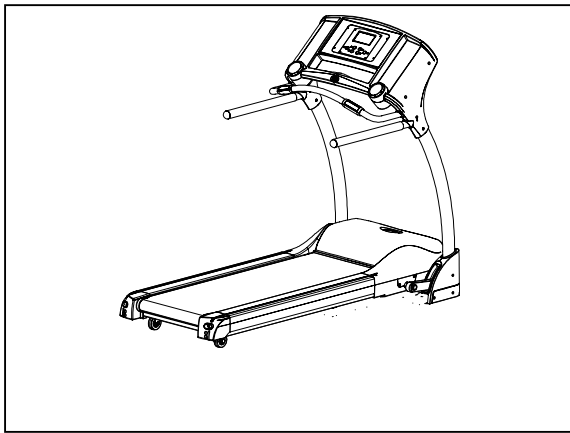

PARTS DIAGRAM

MOST OF THE PARTS SHOWN HERE HAVE ALREADY BEEN PRE-ASSEMBLED.

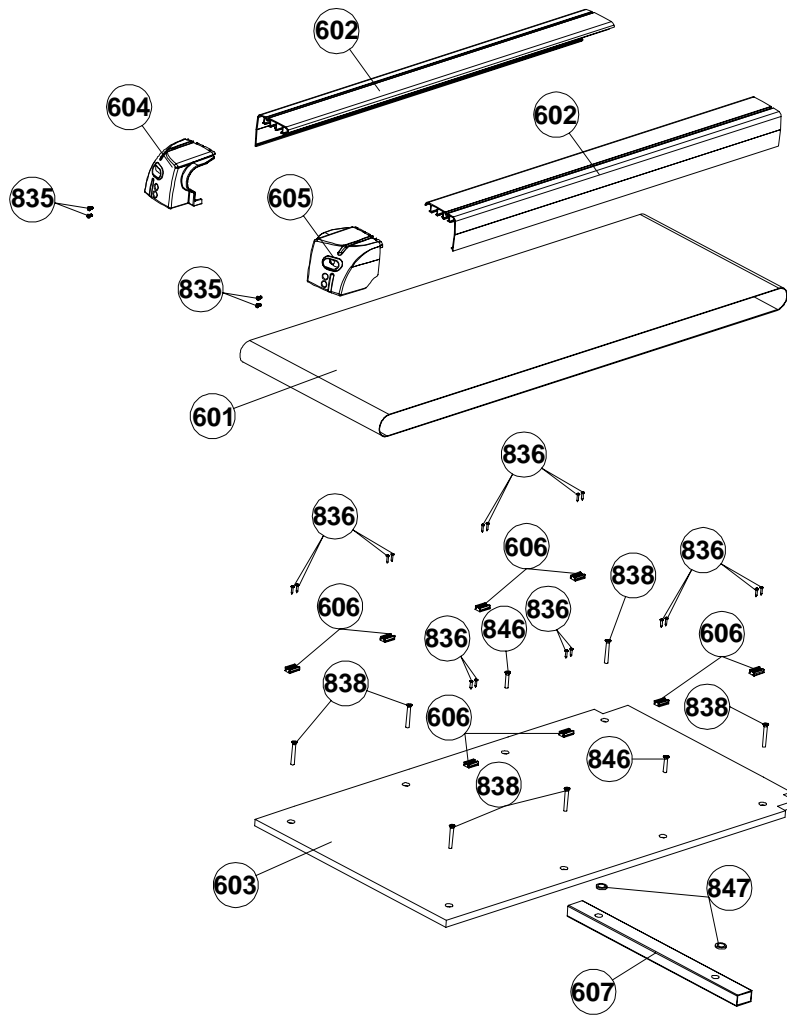
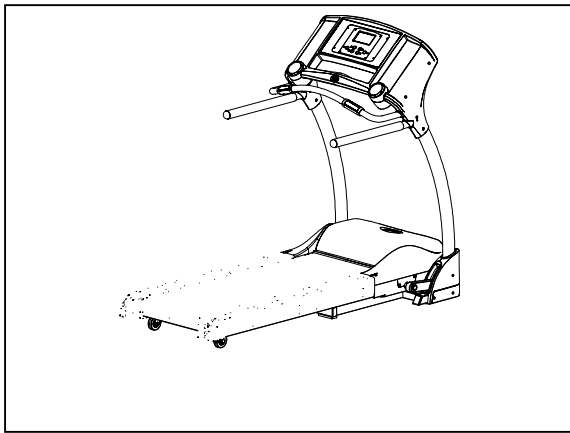

PARTS DIAGRAM

MOST OF THE PARTS SHOWN HERE HAVE ALREADY BEEN PRE-ASSEMBLED.

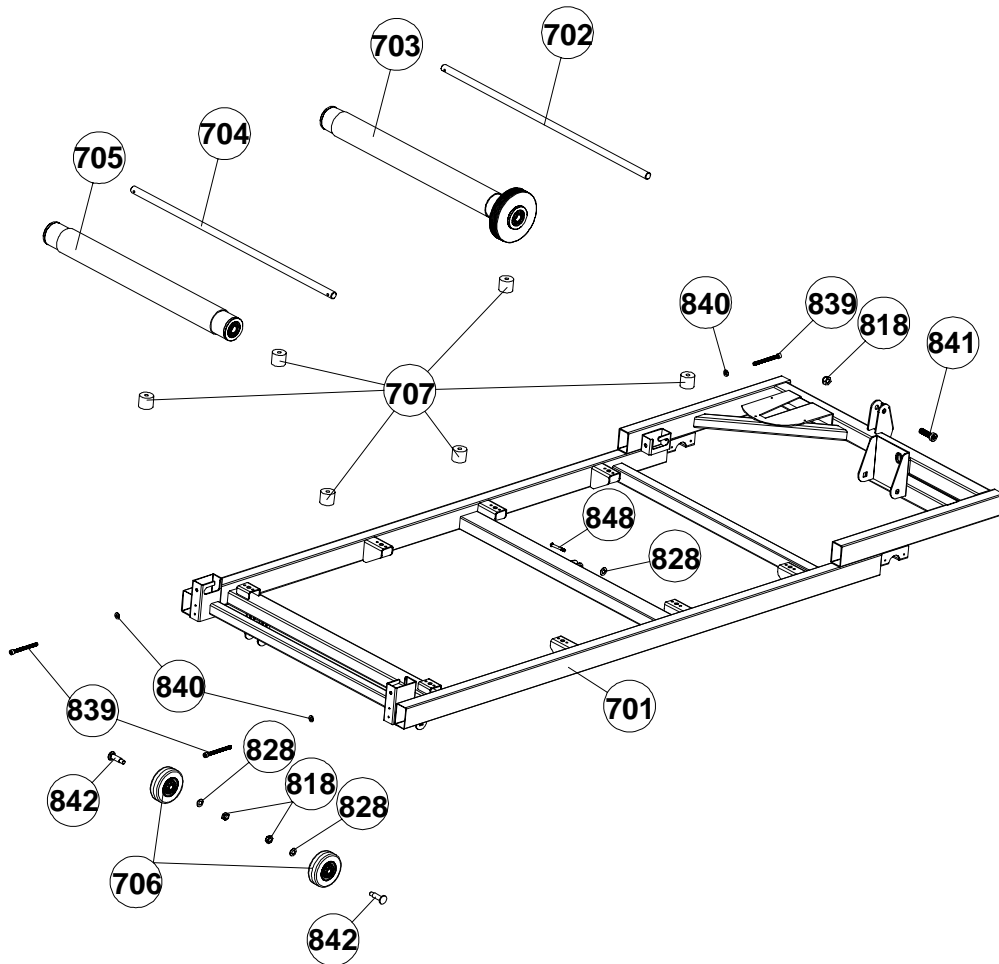
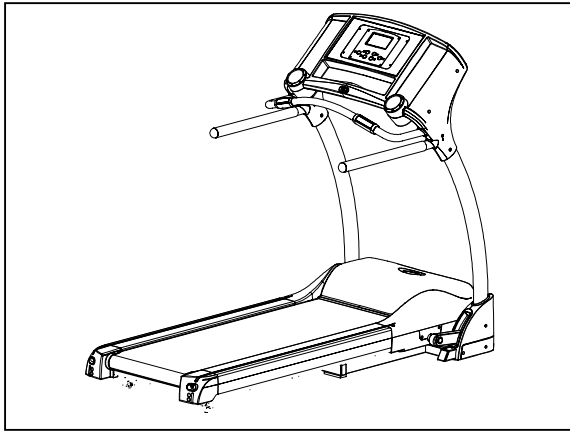

ASSEMBLY**STEP 1: Unpacking and Inventory**

NOTE: FOR SAFER AND EASIER TRANSPORTATION DO NOT REMOVE THE PLASTIC RETAINING STRAPS UNTILL THE UNIT IS IN THE AREA OF ASSEMBLY

Remove the treadmill and all the components and hardware from the box. Check the quantities of all components and hardware with the component and hardware lists on pages 5-6

P.5	Components
P.6	Hardware and tools

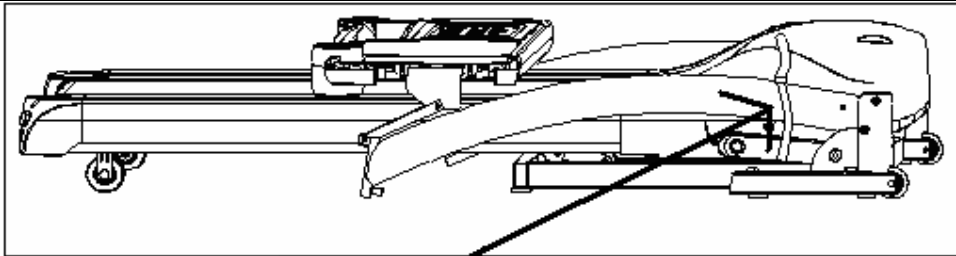
**ATTENTION!!!**

DO NOT REMOVE PLASTIC STRAPS
until the unit is in the location where it
will be assembled

ASSEMBLY**STEP 2: Assemble Upright Frame**

NOTE: Make sure all wires are recessed into the frame. DO NOT trap or pinch (Hand tighten bolts until last step)

- A) Raise the Left and right uprights (301 x 2)
- B) Secure the left upright (301) with two 8x18mm Allen bolts (810) and two # 8 washers through the front side of the base frame. Hand tighten.
- C) Secure the right upright (301) with two 8x18mm Allen bolts (810) and two # 8 washers through the front side of the base frame. Hand tighten.
- D) Insert one M8x52mm Allen bolt (811) and one #8 washer through the side of the base frame and the left upright. Hand tighten.
- E) Insert one M8x52mm Allen bolt (811) and one #8 washer through the side of the base frame and the right upright. Hand tighten.
- F) Tighten all Allen bolts with Allen wrench C (provided with hardware)

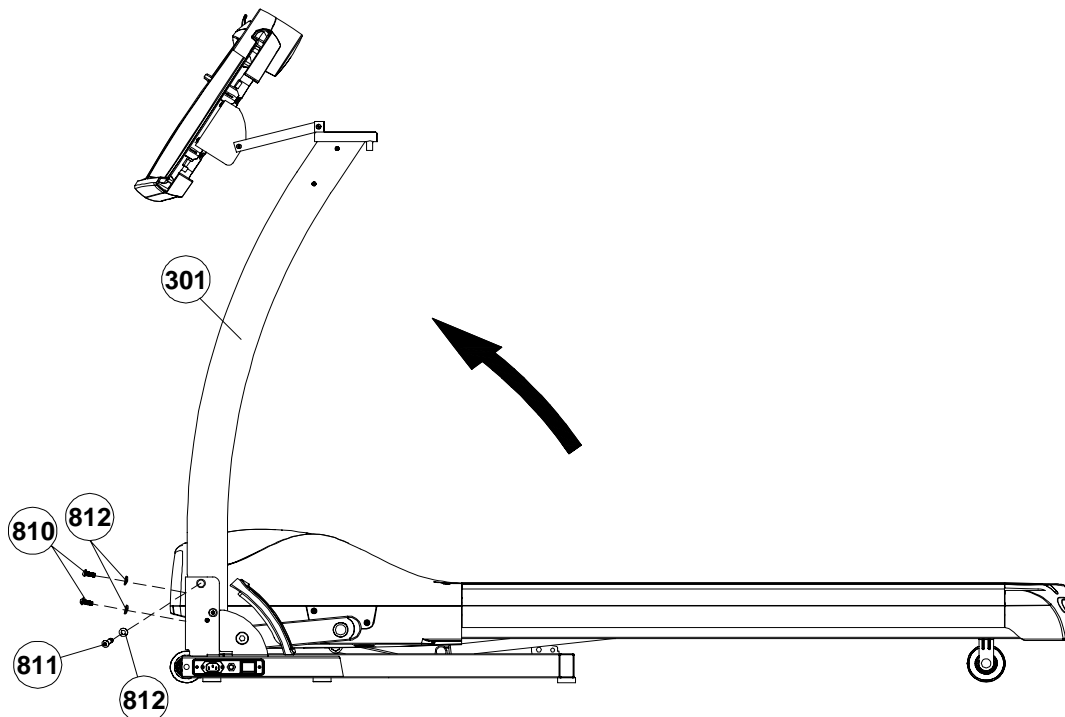
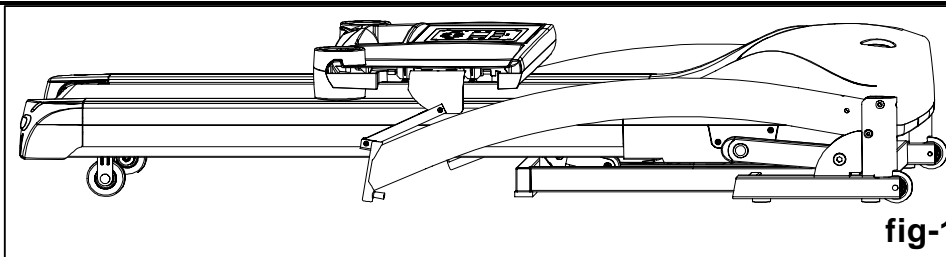
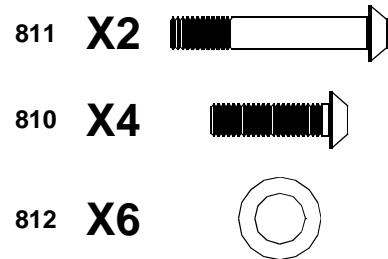

ASSEMBLY**STEP 3: Assemble Front Handle Bar**

Note: Only hand tighten bolts until last step

- A) Place the front handle bar (201) on top of the left and right uprights (301).
- B) Secure left side with one #8 washer (812) and one M8x45mm Allen bolt (805) in the forward most hole
- C) Secure right side with one #8 washer (812) and one M8x45mm Allen bolt (805) in the forward most hole
- D) Connect contact pulse wire (217) and wire (111) on left and right side (as shown in diagram). Then insert the remaining length of wire into the front handle bar tube. Tighten all bolts with Allen wrench.

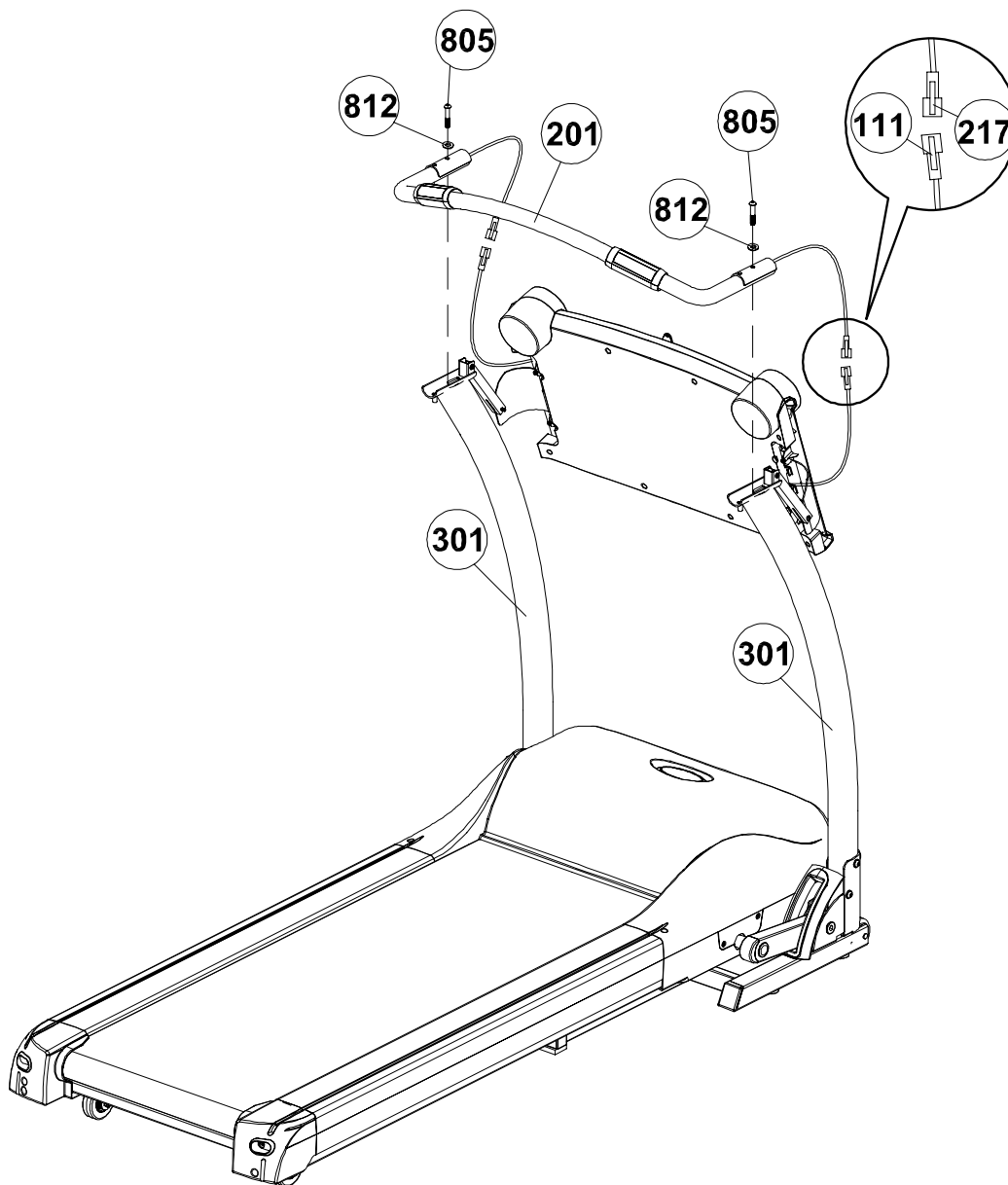
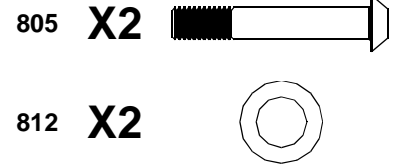

ASSEMBLY**STEP 4: Assemble The Side Handlebars**

NOTE: Side rails are interchangeable for use on both right and left sides

- A) Attach one handlebar (202) to the left upright (301)
- B) Secure the Side Handlebar with one M8x75mm bolt (845) and one #8 washer, through the top of front handle bar into the side handle bar.
- C) Insert two M8x18mm (810) and two #8 washers (812) through the side handrail plate and thread into the upright
- D) Repeat the above process for the right side
- E) Tighten all bolts with Allen wrench

810 X4



845 X2



812 X6

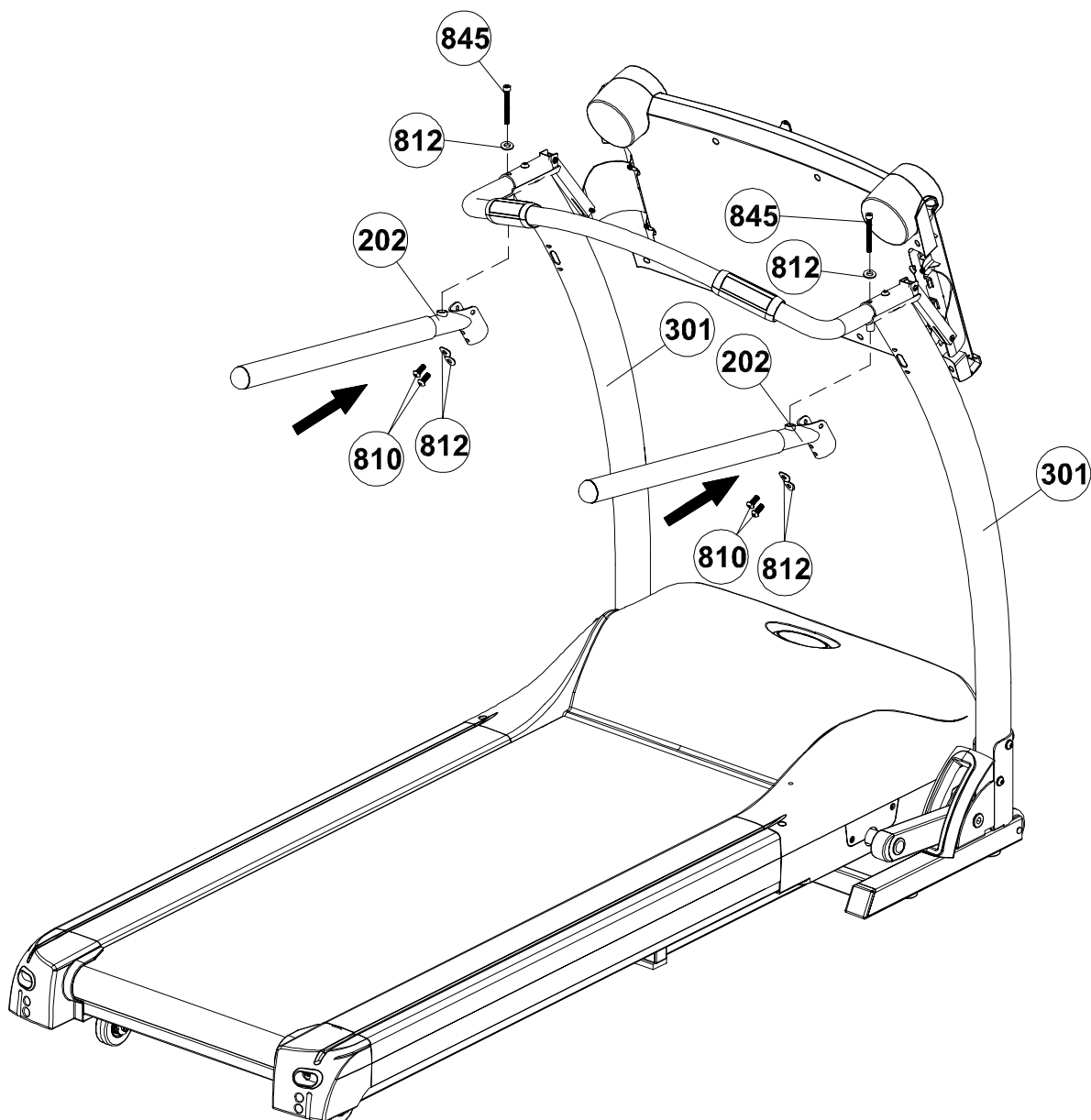

ASSEMBLY**STEP 5: Assemble Computer Console**

- A) Rotate the console up until it stops as shown in diagram below.
- B) Tighten the screw (807) of the console connect tube (213) for right and left side. Console connect tube (213) will be loose for the next steps of assembly.
- C) Attach Handle Bar Cover (208) to the underside of the console and the inside of the Left Upright (301). Secure with four M4x15mm screws (802).
- D) Attach Handle Bar Cover (207) to the top left side of the console and to the outside of the Left Upright. Secure with four M4x15mm screws (802).
- E) Repeat the above process for the right hand side as shown in diagram.(209) (210)

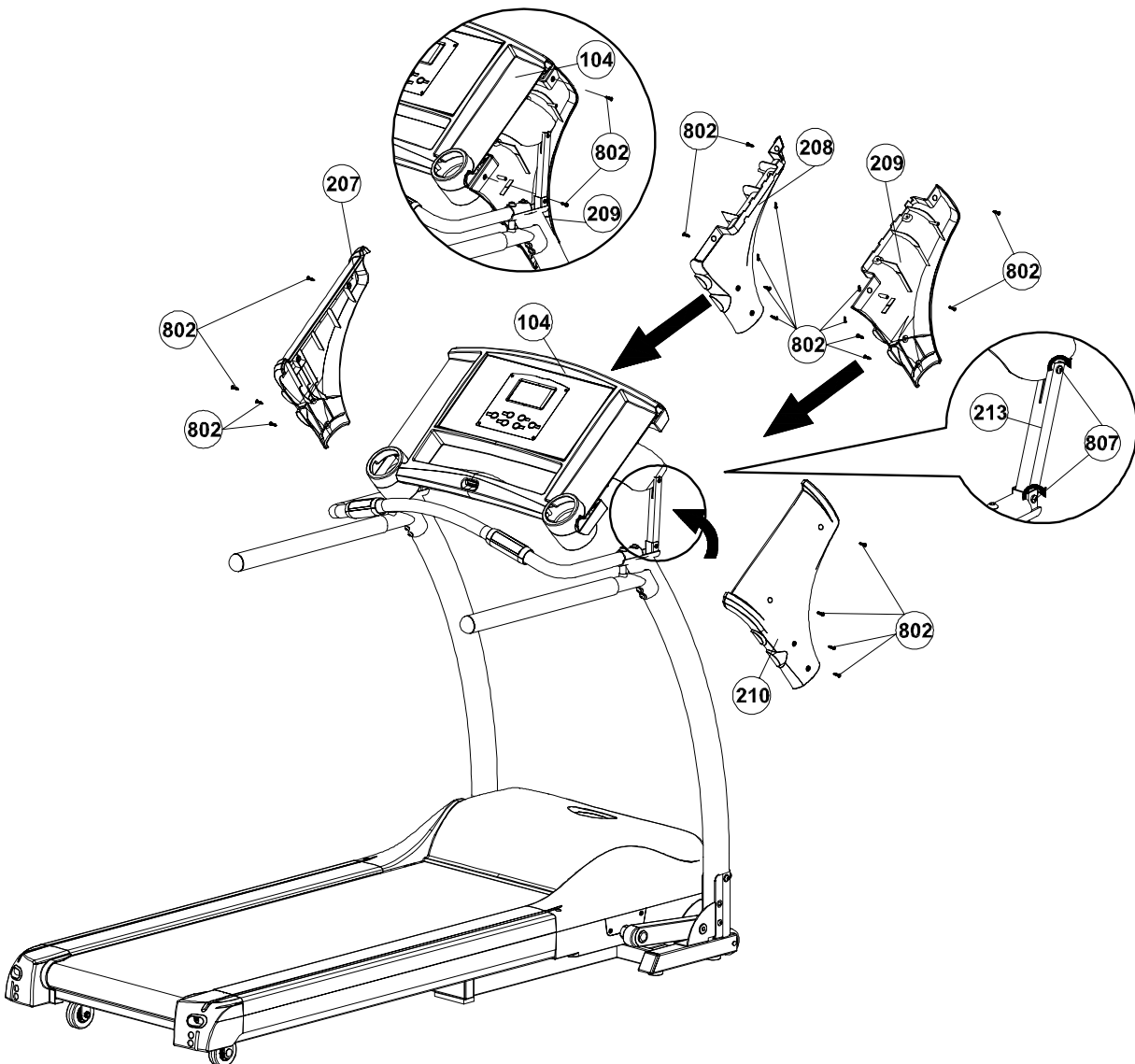
802 **X20** 

ASSEMBLY**STEP 6: Assemble Base Covers**

NOTE: Refer to the folding instructions on page 26.

- A) Fold up the running deck until it locks in place.
- B) Attach Upright Base Cover (302) to the outside of the Left Upright (301). Secure with two M4x15mm screws(802)
- C) Attach Upright Base Cover (303) to the inside of the Left Upright (301). Secure using one M 4x15 mm.
- D) Attach Upright Base Cover (302) to the outside of the Right Upright (301). Secure with three M4x15mm screws(802)
- E) Attach Upright Base Cover (304) to the inside of the Right Upright (301). Secure using one M 4x15 mm.

802 X7 

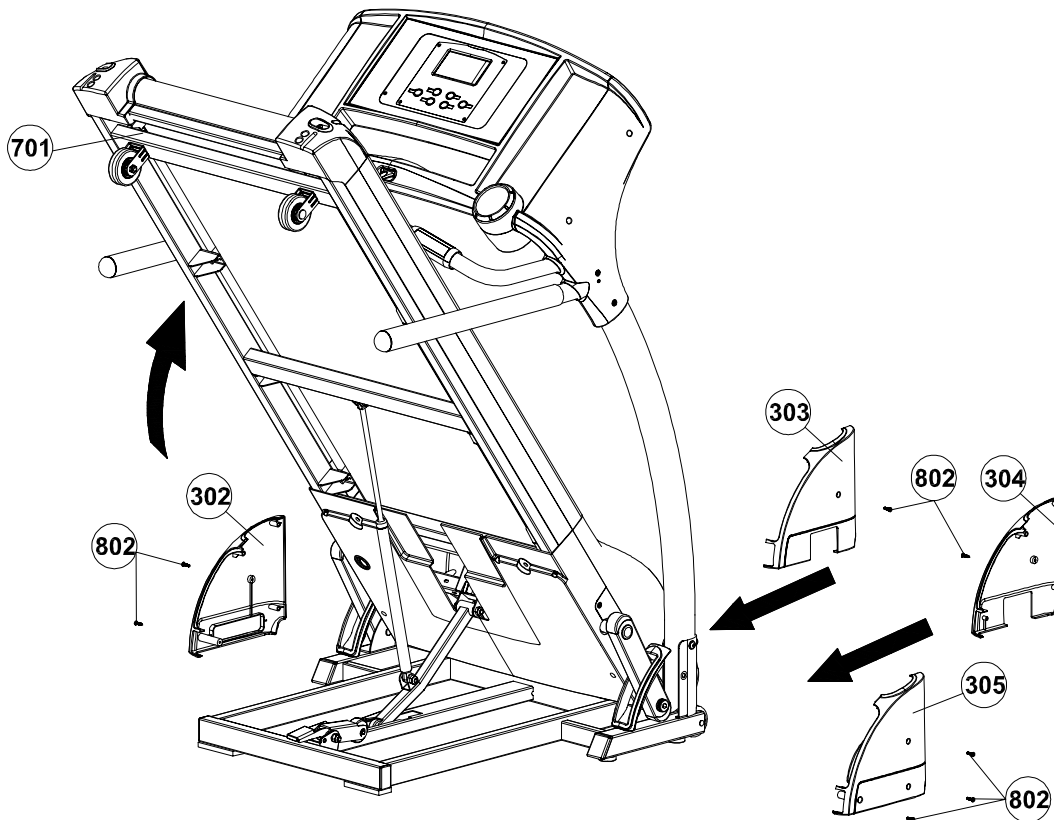

ASSEMBLY

STEP 6: Attaching Rubber Cover

Insert the rubber cover (306) into the slot upright base cover

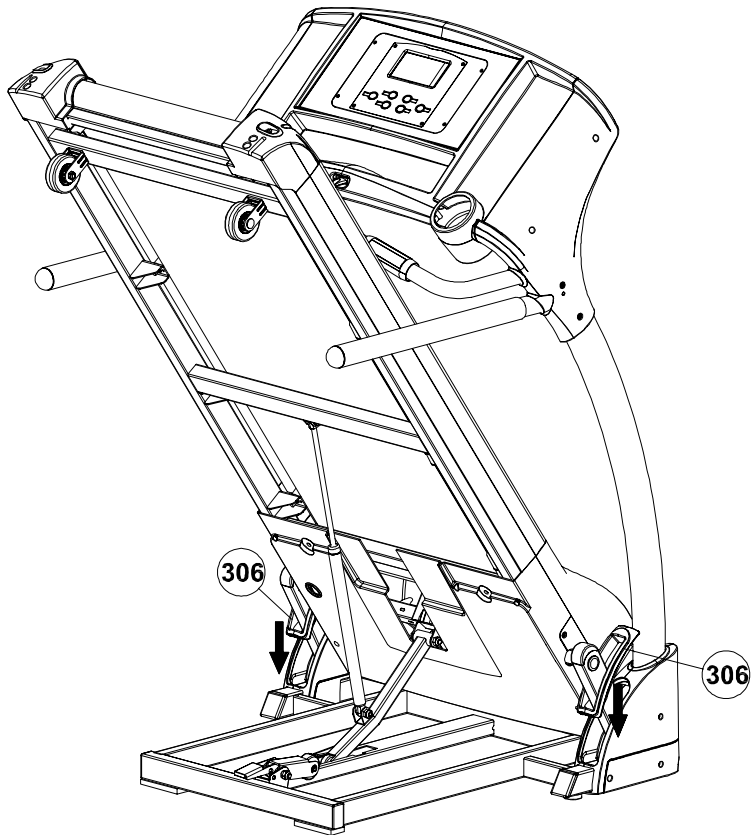

ASSEMBLY**STEP 7: Inserting Water Bottle Holders**

Insert the Water Bottle Holder (108) to the Console Housing - Upper (104). Push down until they snap in place.

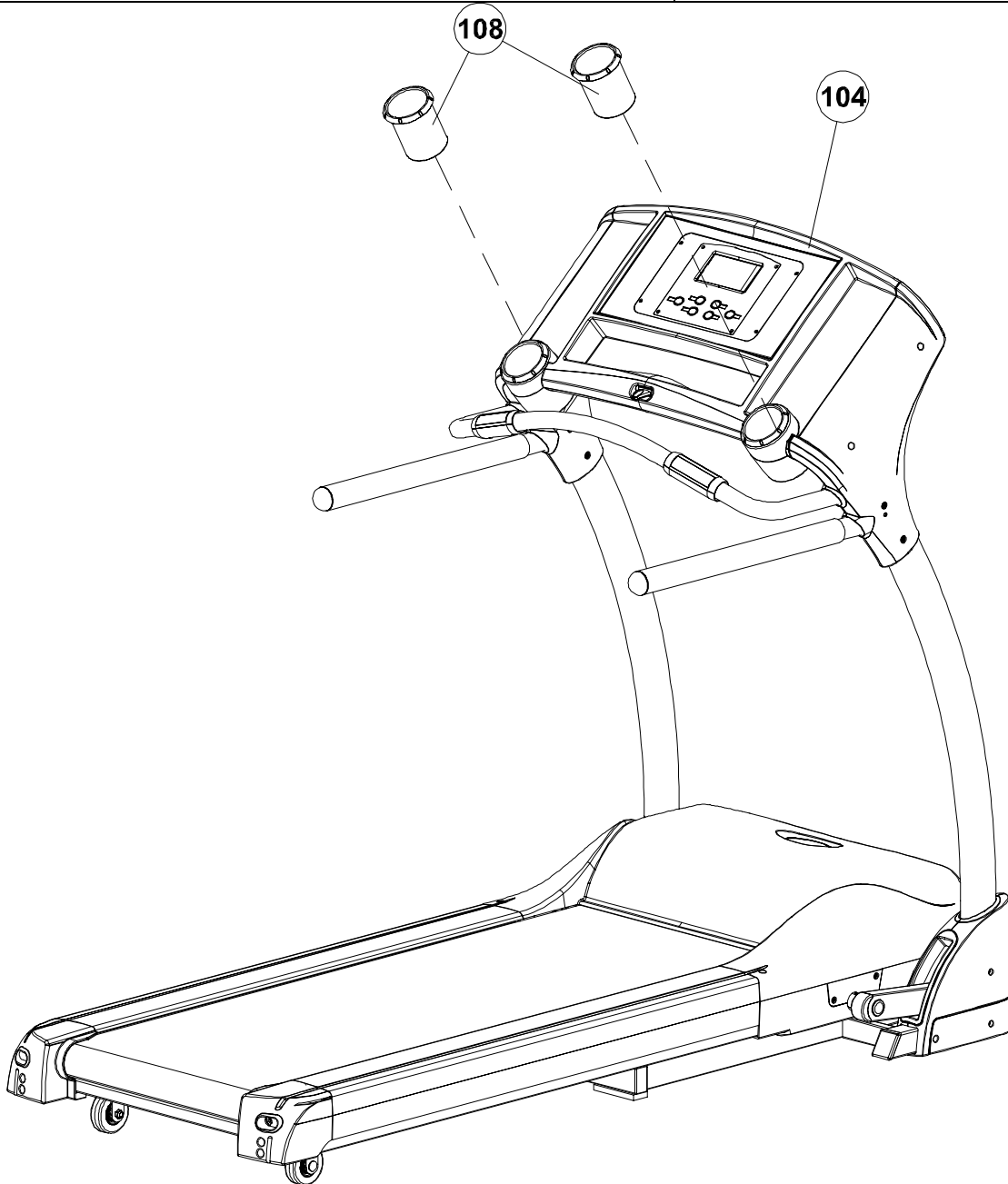

ASSEMBLY COMPLETE

Assembly is now complete. Check that all the components are secure and all the hardware is tight. By this step all bolts and screws should be wrench tight. If any hardware is not wrench tight go back and tighten.

The finished product should resemble the picture below.

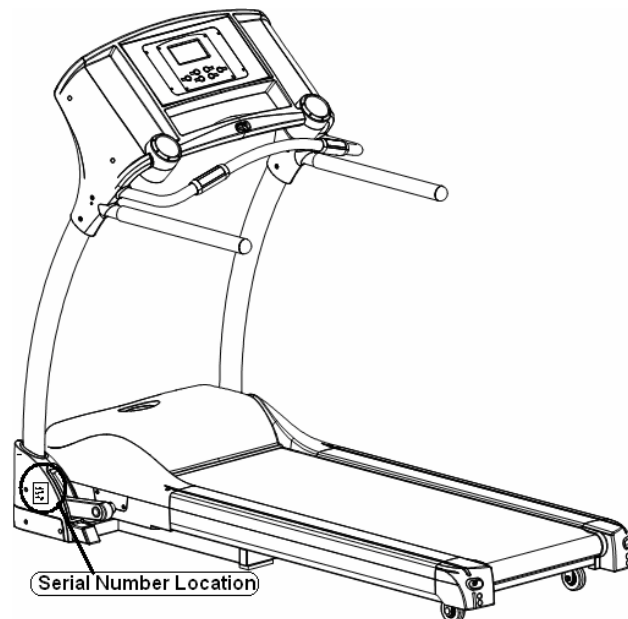
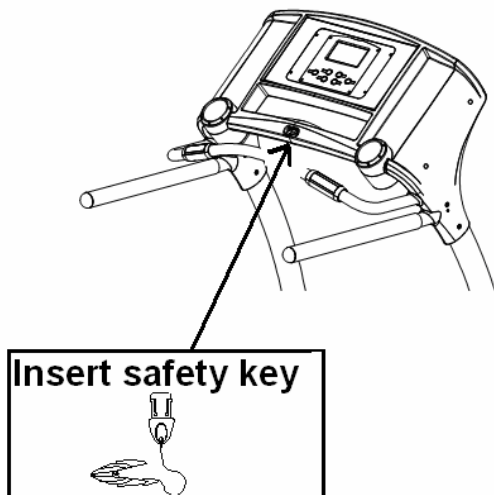
**Safety Features**

The safety key must be inserted for the treadmill to function. The safety key tether should be worn at all times when the treadmill is in use. This safety feature is designed to prevent injury.

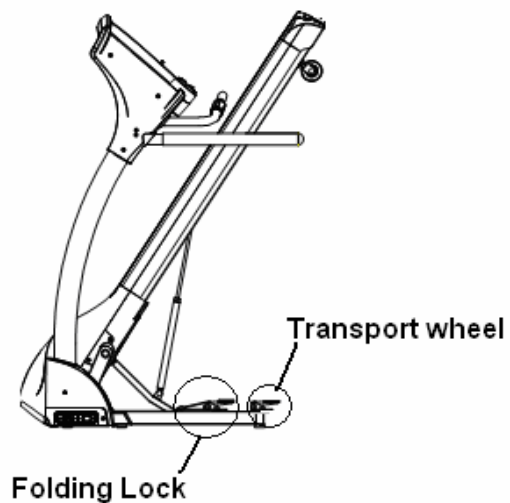

There are two orange levers on this treadmill. The most forward lever is the folding lock which is used in folding and unfolding this treadmill. The other is used for transporting from one location to another

FOLDING INSTRUCTIONS

How to fold up the treadmill:

This treadmill can be folded up for space saving storage. To do this follow the instructions here:

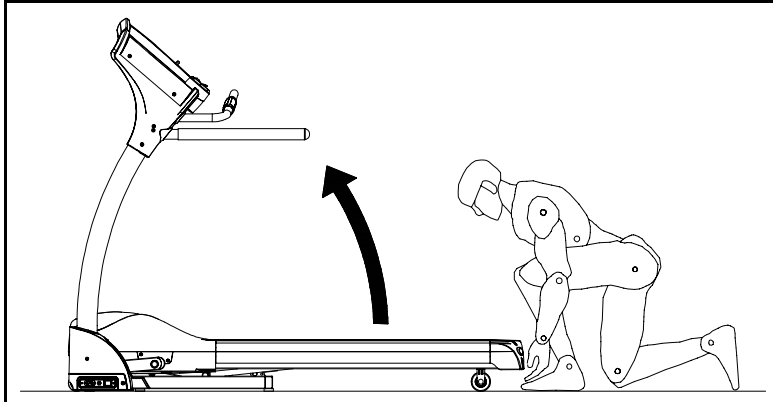

Lift the deck from the rear towards the computer console.

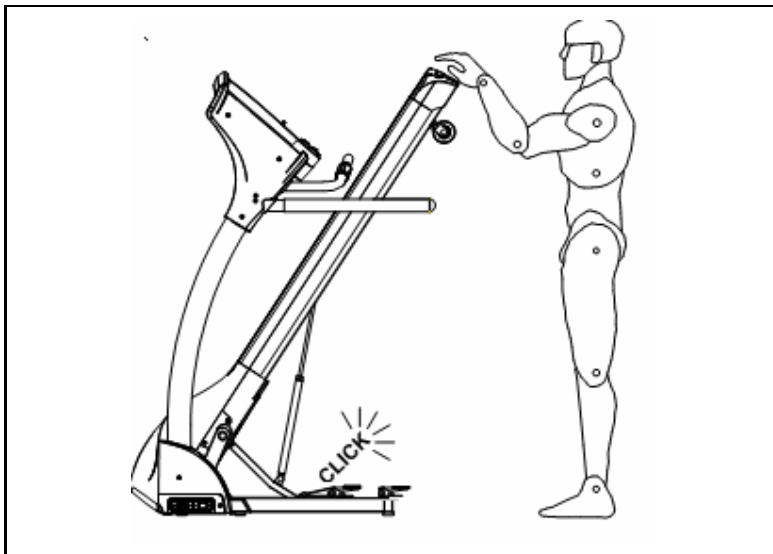

Listen for the click of the Folding Lever locking mechanism.
Be sure locking mechanism is engaged before transporting.
(Transportation instruction on pg 28)

UNFOLDING INSTRUCTIONS

How to unfold the treadmill:

NOTE: To maintain stability make sure the rear transportation wheel is disengaged before unfolding treadmill

To unfold the treadmill for use follow the instructions here:

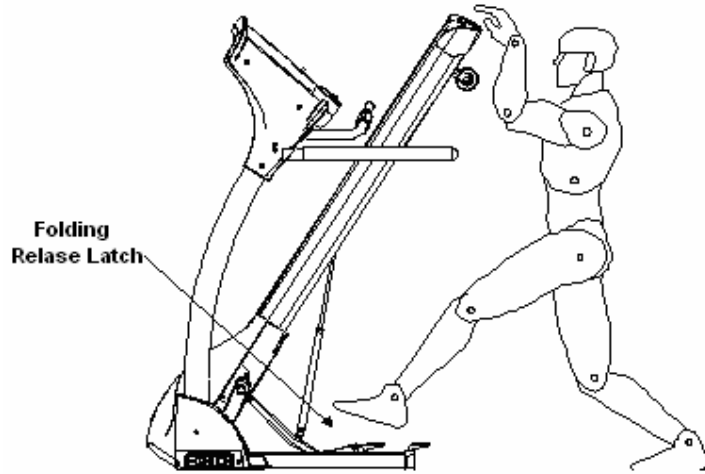

Push the deck towards the computer console.
Depress the Folding Lever begin lowering the treadmill
towards the floor release the Folding Lever

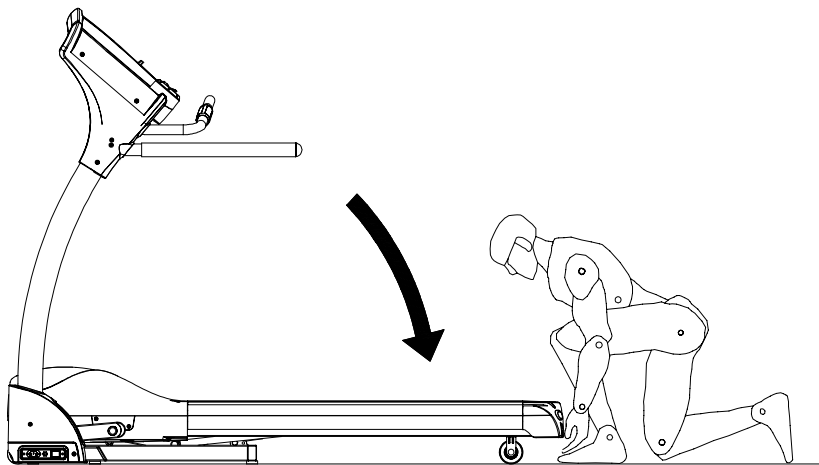

Lower treadmill deck towards floor.

TRANSPORT INSTRUCTIONS

TRANSPORT INSTRUCTIONS:

NOTE: Transport wheel must be down as pictured below

To roll away for storage simply grab the rear deck, lift slightly and roll to desired location.

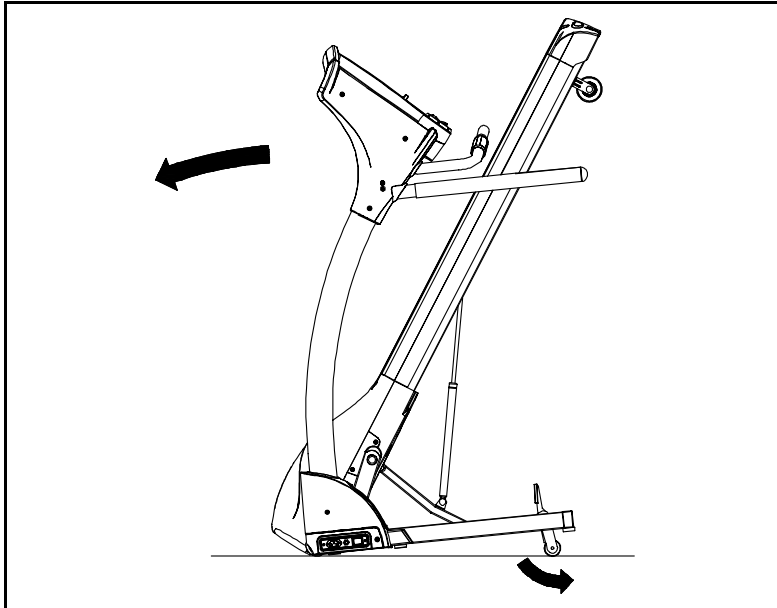

Lift the deck from the rear so that the treadmill rests on the front transportation wheels and rear transportation wheel engages

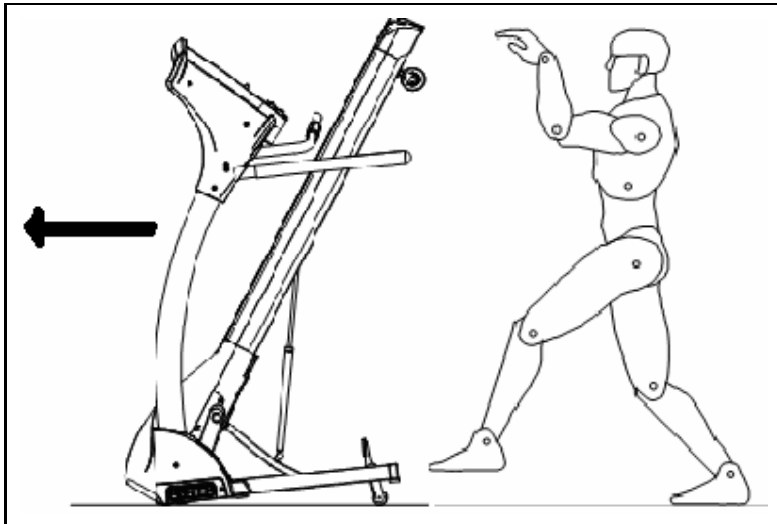

Roll to a desired location.

MAINTAINENCE

HOW TO MAINTAIN THE Smooth -5.25 TREADMILL:

Proper maintenance is very important to ensure your treadmill is always in top working condition. Improper maintenance could cause damage or shorten the life of your treadmill and exceed the LIMITED WARRANTY coverage.

- **Important: DO NOT** use abrasives or solvents to clean the treadmill. To prevent damage to the computer, keep liquids away and keep it out of direct sunlight.
- Inspect and tighten all parts of the treadmill regularly. Replace any damaged or worn parts immediately.

BELT ADJUSTMENT:

ALL BELT ADJUSTMENTS ARE CONSIDERED MAINTENIANCE, AND ARE THE RESPONSIBILITY OF THE END USER.

Belt adjustment and tension performs two functions: adjustment for tension and centering. The running belt has been adjusted properly at the factory. However transportation, uneven flooring or other unpredicted reasons could cause the belt to shift off center resulting in the belt rubbing on the plastic side rail or end caps and possibly causing damage to the equipment. To adjust the belt back to it's proper position please follow the directions below:

- **Walking belt has shifted to the left:** First unplug the power cord from the surge protector. Using the hex key provided, turn the left rear roller adjustment bolt 1/4 turn in the clockwise direction. Plug the power cord back into the surge protector and run the treadmill at 2.5 mph. You should see the belt start to correct itself, moving back towards the center. Repeat the above procedure until the walking belt is centered. It may be necessary to set walking belt tension once you have completed this procedure if the belt feels like it is slipping while walking. Refer below to the "Walking belt slipping" instructions.
- **Walking belt has shifted to the right:** First unplug the power cord from the surge protector. Using the hex key provided, turn the right rear roller adjustment bolt 1/4 turn in the clockwise direction. Plug the power cord back into the surge protector and run the treadmill at 2.5 mph. You should see the belt start to correct itself, moving back towards the center. Repeat the above procedure until the walking belt is centered. It may be necessary to set walking belt tension once you have completed this procedure if the belt feels like it is slipping while walking. Refer below to the "Walking belt slipping" instructions.
- **Walking belt is slipping:** First unplug the power cord from the surge protector. Using the hex key provided, turn both the left and right rear roller adjustment bolts the equal amounts, 1/2 turn in the clockwise direction. Plug the power cord back into the surge protector and run the treadmill at 2.5 mph. You should now walk on the belt to determine if the belt is still slipping. Repeat the above procedure until the walking belt is not slipping. The tension should be just tight enough not to slip. If proper tension cannot be achieved within four attempts please contact Smooth Fitness Technical Support. Belt centering may be necessary once you have completed the tensioning procedure.

WARNING! Do not over tighten rollers! This will cause premature roller bearing failure!

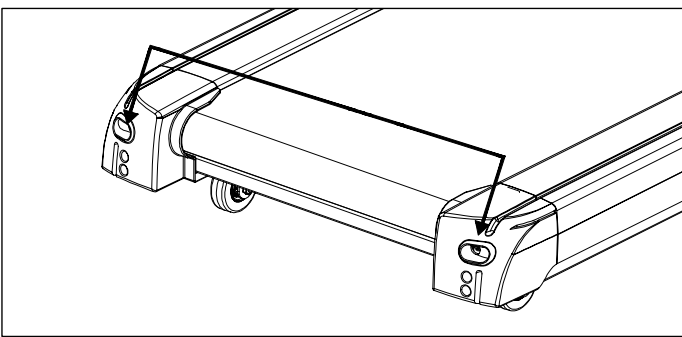

Right and left tension bolts are located at the rear of the treadmill.

MAINTAINENCE

CLEANING:

Routine cleaning of your treadmill will extend the product's life.

- **Warning:** To prevent electrical shock, be sure the power to the treadmill is OFF and the power cord is unplugged from the wall electrical outlet before attempting any cleaning or maintenance.
- **Important: DO NOT** use abrasives or solvents to clean the treadmill. To prevent damage to the computer, keep liquids away and keep it out of direct sunlight.
- **After each workout:** Wipe off the console and other treadmill surfaces with a clean, water dampened soft cloth to remove excess perspiration.
- **Weekly:** Use of a treadmill mat is recommended for ease of cleaning. Dirt from your shoes contacts the belt and eventually makes it to underneath the treadmill. Vacuum underneath treadmill once a week.

DECK LUBRICATION:

The walking belt has been pre-lubricated at the factory. However, it is recommended that the running deck be checked periodically for lubrication to ensure optimal treadmill performance. Your treadmill should not have to be lubricated usually within the first 400 hours of use.

Every 2 months of operation lift the sides of the walking belt and feel the top surface of the running deck as far as you can reach. If you feel signs of silicone, no further lubrication is required. If it feels dry to the touch, follow the instructions below.

. To purchase lubricant Kit please contact Smooth Fitness 1-888-800-1167

To apply lubricant under the walking belt:

1. Position the walking belt so that the seam is located on top and in center of the walking board.
2. Insert the spray nozzle into the spray head of the lubricant can.
3. While lifting the side of the walking belt, position the spray nozzle between the walking belt and the board approximately 6" from the front of the treadmill and as far to the center as possible. Apply the silicone spray to the walking board, moving from the front of the treadmill to the rear. Repeat this on the other side of the belt. Spray approximately 1/4 bottle (supplied with treadmill) each time.
4. Allow the silicone to "set" for 1 minute before using the treadmill.

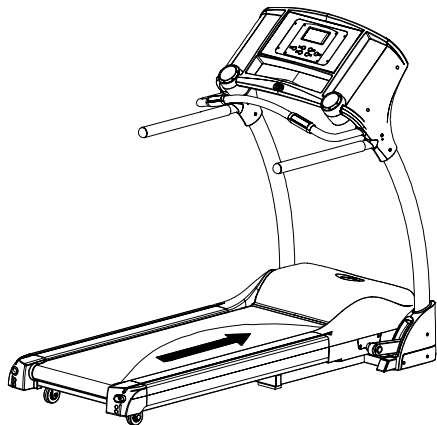

Apply from front to back.

IMPORTANT STEPS

Warning:

Before using this product, please consult your personal physician for a complete physical examination. Frequent and strenuous exercise should be approved by your doctor prior to use. If any discomfort should result from your use of this product, stop exercising and consult your doctor. Proper usage of this product is essential. Please read your manual carefully before exercising.

Please keep all children away from the equipment during use and when equipment is unattended.

Always wear appropriate clothing, including athletic shoes, when exercising. Do not wear loose clothing that could become caught during exercising.

Make sure that all bolts and nuts are tightened before each use. Periodic maintenance is required on all exercise equipment to keep it in good condition.

Before beginning:

How you begin your exercise program depends on your physical condition. If you have been inactive for several years, or are severely overweight, you must start slowly and increase your time gradually, a few minutes per week.

Initially you may be able to exercise only for a few minutes in your target zone. However, your aerobic fitness will improve over the next six to eight weeks. Don't be discouraged if it takes longer. It's important to work at your own pace. Ultimately, you'll be able to exercise continuously for 30 minutes. And the better your aerobic fitness, the harder you will have to work to stay in your target zone. But remember these essentials:

- Contact your physician before starting a workout or training program. Have your doctor review your training and diet programs to advise you of a workout routine you should adopt.
- Begin your training program slowly with realistic goals that have been set by you and your doctor.
- Supplement your program with some type of aerobic exercise such as walking, jogging, swimming, dancing and/or bicycling. Monitor your pulse frequently. If you do not have an electronic heart rate monitor, have your physician show you the proper way to manually check your pulse by using your wrist or neck. Establish your target heart rate based on your age and condition.
- Drink plenty of fluids during the course of your routine. You must replace the water content lost from excessive exercising to avoid dehydration. Avoid drinking large amounts of cold liquids. Fluids should be at room temperature when consumed.



The Surgeon General
has determined that lack
of physical activity is
detrimental to your health.™

TARGET HEART RATE

Finding your pulse:

To make sure your heart is beating in its target zone, you'll need to know how to monitor your heart rate. The easiest way is to feel the pulse in the carotid artery on either side of your neck, between the windpipe and the large neck muscles. Count the number of beats in ten seconds, and then multiply that number by six. This gives you the number of beats per minute.

How fast should your heart beat during aerobic exercise? Fast enough to reach and stay in its "target zone," a range of beats per minute that is largely determined by your age and physical condition. To determine your target zone, consult the chart we have provided.

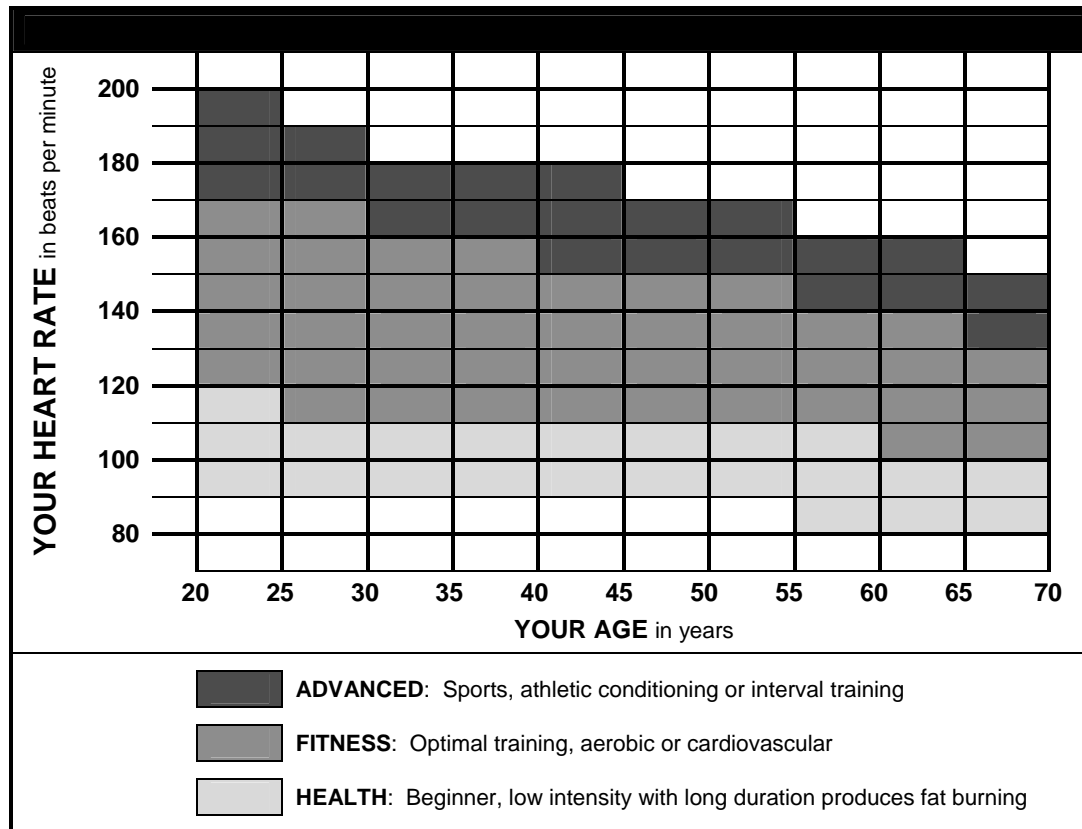

Aerobic exercise:

Is any sustained activity that sends oxygen to your muscles via your heart and lungs. It will improve the fitness of your lungs and heart: your body's most important muscle. Aerobic fitness is promoted by any activity that uses your large muscle groups - arms, legs or buttocks, for example. Your heart beats quickly and you breathe deeply. An aerobic exercise should be part of your entire exercise routine.







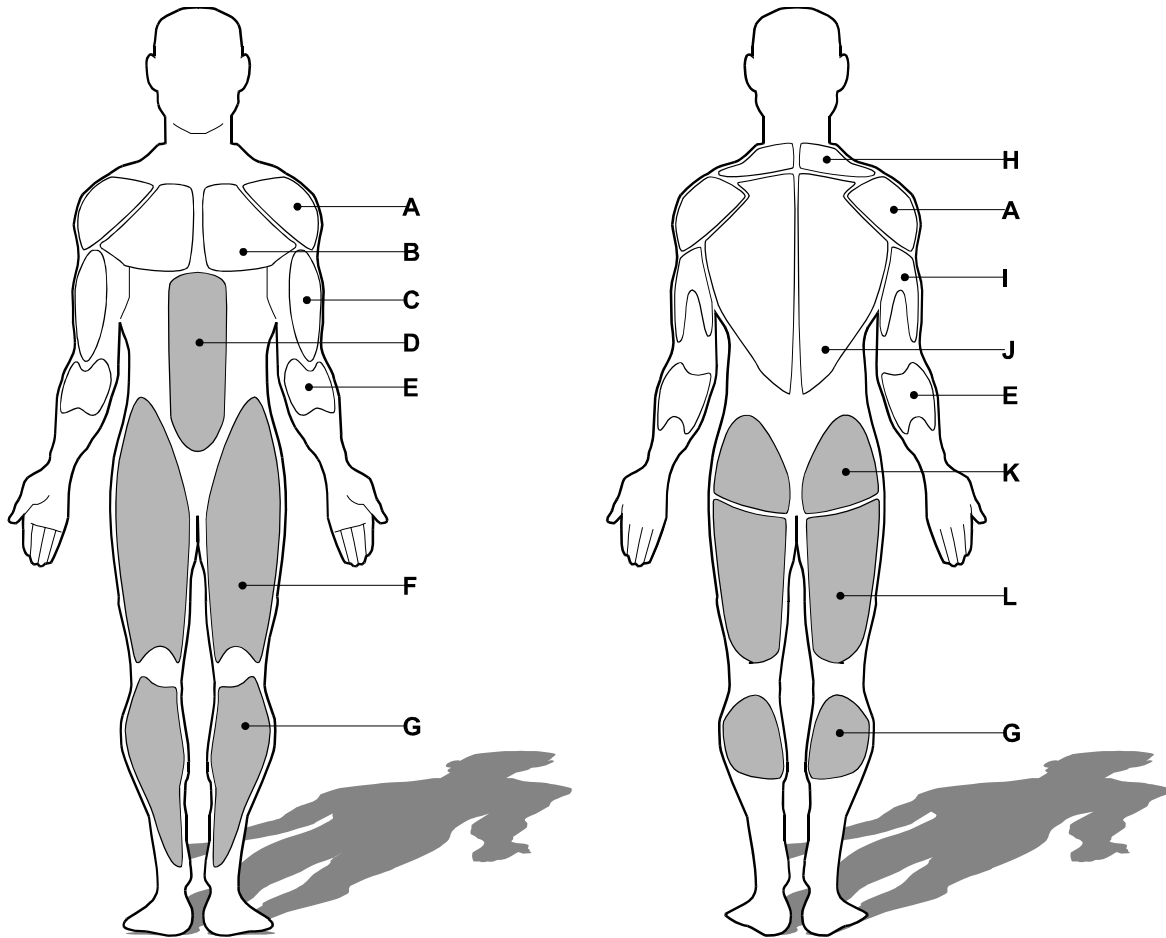





MUSCLE CHART

Targeted muscle groups:

The exercise routine that is performed on this product will develop primarily lower body muscle groups. These muscle groups are shown in gray color on the chart below.



MUSCLE GROUPS

	Shoulder muscles		Calf muscles
	Pectoral muscles		Trapezius muscles
	Bicep muscle		Tricep muscles
	Abdominal muscles		Back muscles
	Forearm muscles		Gluteal muscles
	Quadricep muscles		Hamstring muscles

STRETCHING ROUTINE

Warm up and cool down:

A successful exercise program consists of a warm-up, aerobic exercise, and a cool-down. Do the entire program at least two and preferably three times a week, resting for a day between workouts. After several months, you can increase your workouts to four or five times per week.

Warming up is an important part of your workout, and should begin every session. It prepares your body for more strenuous exercise by heating up and stretching out your muscles, increasing your circulation and pulse rate, and delivering more oxygen to your muscles. At the end of your workout, repeat these exercises to reduce sore muscle problems. We suggest the warm-up and cool-down exercises on the following pages:

Slowly bend forward from your waist, letting your back and shoulders relax as you stretch toward your toes. Reach down as far as you can and hold for 15 counts.

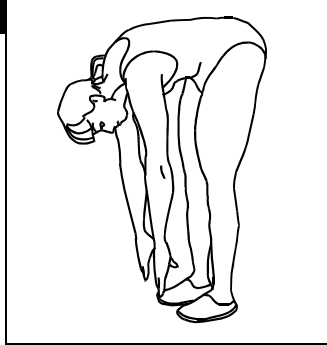

Lift your right shoulder up toward your ear for one count. Then lift your left shoulder up for one count as you lower your right shoulder.

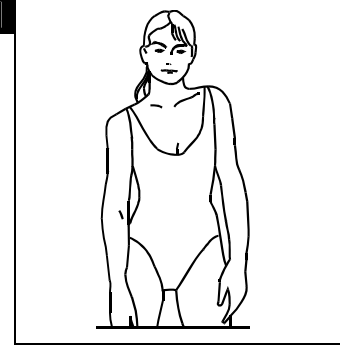

Sit with the soles of your feet together with your knees pointing outward. Pull your feet as close into your groin as possible. Gently push your knees towards the floor. Hold for 15 counts.

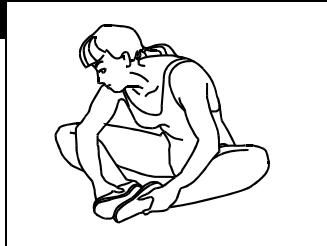

Sit with your right leg extended. Rest the sole of your left foot against your right inner thigh. Stretch toward your toe as far as possible. Hold for 15 counts. Relax and then repeat with left leg extended.

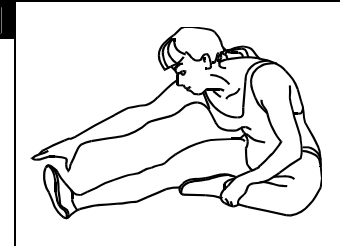

Open your arms to the side and continue lifting them until they are over your head. Reach your right arm as far upward toward the ceiling as you can for one count. Feel the stretch up your right side. Repeat this action with your left arm.

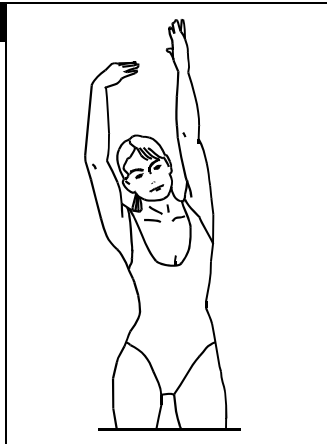

Lean against a wall with your left leg in front of the right and your arms forward. Keep your right leg straight and the left foot on the floor; then bend the left leg and lean forward by moving your hips toward the wall. Hold, and then repeat on the other side for 15 counts.

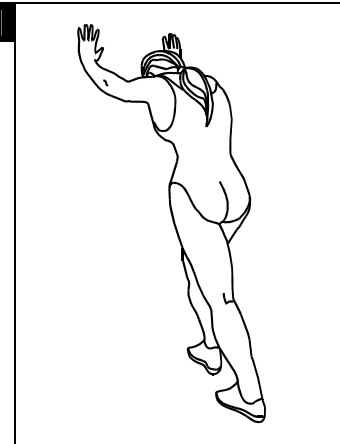

Rotate your head to the right for one count, feeling the stretch up the left side of your neck. Next, rotate your head back for one count, stretching your chin to the ceiling and letting your mouth open. Rotate your head to the left for one count, and finally, drop your head to your chest for one count.

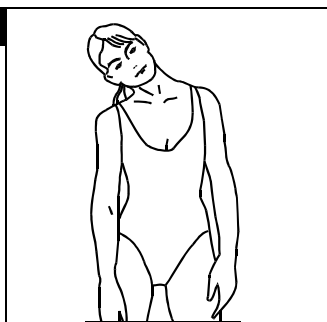

TROUBLESHOOTING

NOTE: Do not touch any internal electric wires without consulting the manufacturer.

Treadmill will not start:

Symptom	Resolution
Treadmill will not power up	Check the following:
	<ul style="list-style-type: none"> ▪ Make sure the power cord is plugged into a surge protector, the surge protector is plugged into a properly grounded outlet and the surge protector is turned on (refer to the Power Requirements section in this manual).
	<ul style="list-style-type: none"> ▪ Equipment circuit breaker is in the reset position
	<ul style="list-style-type: none"> ▪ Equipment power switch is in the on position
	<ul style="list-style-type: none"> ▪ Safety key is properly inserted into the computer console
Treadmill stops operation during use	<ul style="list-style-type: none"> ▪ Wall outlet is properly functioning with correct voltage (Have an electrician check for inadequate voltage at the outlet refer to the Power Requirements section in this manual)
	<ul style="list-style-type: none"> ▪ House circuit breaker is reset and is the proper size. (refer to the Power Requirements section in this manual)
	<ul style="list-style-type: none"> ▪ Safety key is properly inserted into the computer console
	<ul style="list-style-type: none"> ▪ Equipment circuit breaker is in the reset position
Treadmill will not incline(Power fold models only)	<ul style="list-style-type: none"> ▪ House circuit breaker is reset, meets proper requirements and if worn replaced by an electrician. (refer to the Power Requirements section in this manual)
Treadmill will not unfold	<ul style="list-style-type: none"> ▪ Program time has expired
	<ul style="list-style-type: none"> ▪ Check for proper positioning of spring knob for folding(See procedure in owners manual)
Treadmill running belt moves slower than speed displayed on computer	Power Fold only
	<ul style="list-style-type: none"> ▪ Check for proper positioning of spring knob for folding(See procedure in owners manual)
Treadmill running belt moves slower than speed displayed on computer	Manual Fold only
	<ul style="list-style-type: none"> ▪ Folding locking lever is depressed
Treadmill running belt moves slower than speed displayed on computer	<ul style="list-style-type: none"> ▪ Metric/English conversion (See owners manual for Metric/English conversion process)
Running belt is not centered	<ul style="list-style-type: none"> ▪ Metric/English conversion (See owners manual for Metric/English conversion process)
	<ul style="list-style-type: none"> ▪ Treadmill is properly leveled(See procedure in owners manual)
Running belt is slipping or hesitating while in use	<ul style="list-style-type: none"> ▪ Center running belt (See Centering procedure in owners manual)
	<ul style="list-style-type: none"> ▪ Tension running belt (See process in owners manual)
Treadmill running belt moves slower than speed displayed on computer	<ul style="list-style-type: none"> ▪ Metric/English conversion (See owners manual for Metric/English conversion process)
Running belt is not centered	<ul style="list-style-type: none"> ▪ Treadmill is properly leveled(See procedure in owners manual)
	<ul style="list-style-type: none"> ▪ Center running belt (See Centering procedure in owners manual)
Running belt is slipping or hesitating while in use	<ul style="list-style-type: none"> ▪ Tension running belt (See process in owners manual)



Smooth Fitness
112 Gaither Drive
Mt. Laurel, NJ 08054

Toll Free Customer Service:
1.888.800.1167

Website:
www.smoothfitness.com

