

# 735 MOTORIZED TREADMILL

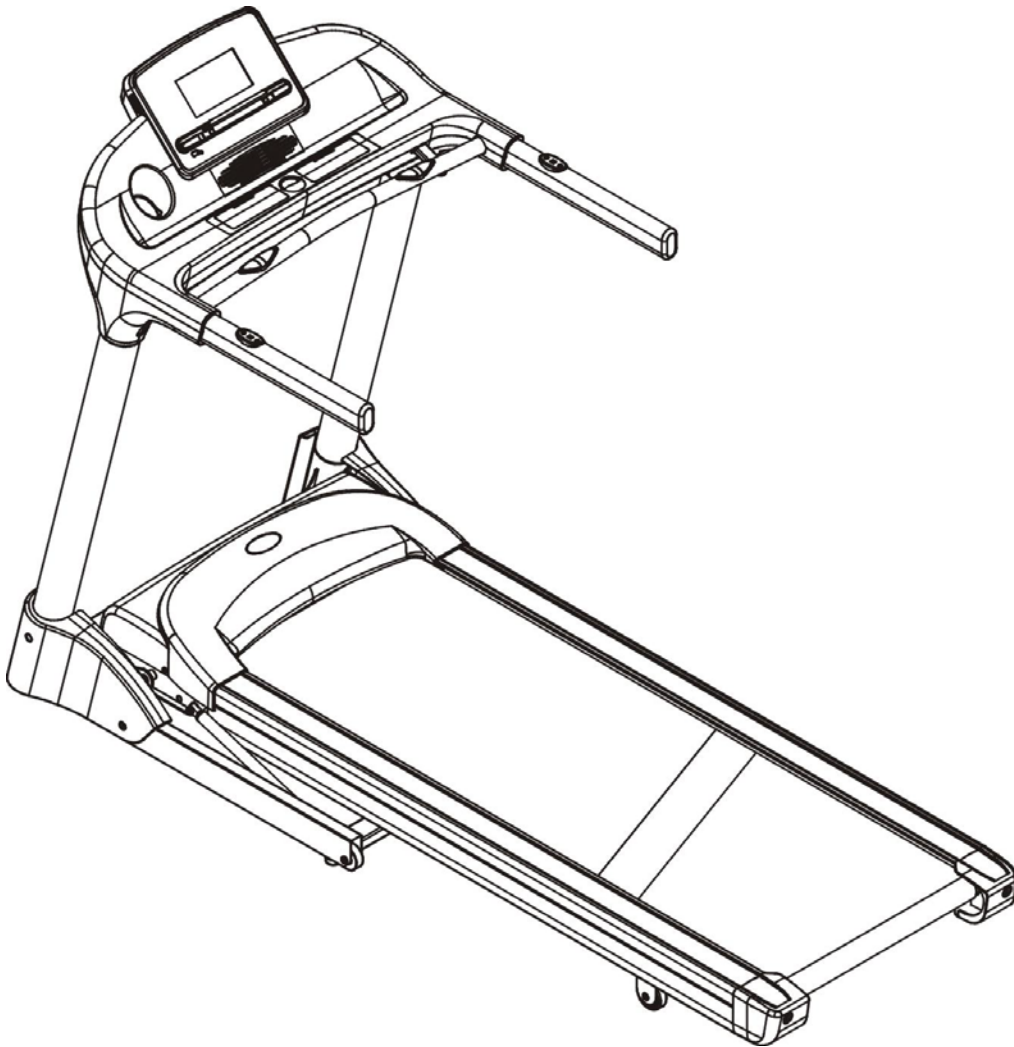

USER WEIGHT LIMITATION: **350lbs(160kgs).**

SERIAL NUMBER (found on frame):

## PRECAUTIONS

### For future service or related questions:

Please staple your receipt and/or write in the name and phone number of the retail store where you purchased your treadmill.

Name: \_\_\_\_\_ Phone Number: \_\_\_\_\_ Receipt: \_\_\_\_\_

### Precautions:

**WARNING:** To reduce the risk of burns, fire, electric shock, or injury to persons, read the following important precautions and information before operating the treadmill. It is the responsibility of the owner to ensure that all users of this treadmill are adequately informed of all warnings and precautions.

- Use the treadmill only as described in this manual.
- Place on a level surface, with 6 feet 2 X1m of clearance behind it. Do not place the treadmill on any surface that blocks air openings. To protect the floor or carpet from damage, place a mat under the treadmill.
- When choosing a location for the treadmill be sure that the location and position permit access to a plug.
- Keep the treadmill indoors, away from moisture and dust. Do not put the treadmill in a garage or covered patio, or near water.
- Do not operate the treadmill where aerosol products are used or where oxygen is being administered.
- Keep children under the age of 12 and pets away from the treadmill at all times.
- The treadmill should not be used by persons weighing more than **350LBS (160 Kgs)**.
- Never allow more than one person on the treadmill at a time. Wear appropriate exercise clothing when using the treadmill. Do not wear loose clothing that could become caught in the treadmill. Athletic support clothes are recommended for both men and women. Always wear athletic shoes. Never use the treadmill with bare feet, wearing only stockings, or in sandals.
- When connecting the power cord, plug the power cord into a grounded circuit. No other appliance should be on the same circuit.
- Always straddle the belt and allow it to start moving before stepping onto the belt.
- Always examine your treadmill before using to ensure all parts are in working order.
- Allow the belt to fully stop before dismounting.
- Never insert any object or body parts into any opening.
- Follow the safety information in regards to plugging in your treadmill.
- Keep the power cord away from the incline wheels and do not run the power cord underneath your treadmill. Do not operate the treadmill with a damaged or frayed power cord.
- Always unplug the treadmill before cleaning and/or servicing. Service to your treadmill should only be performed by an authorized service representative, unless authorized and/or instructed by the manufacturer. Failure to follow these instructions will void the treadmill warranty.
- Never leave the treadmill unattended while it is running.
- Use "safety key" when operating the treadmill and make sure the "safety key" is clipped to the users clothing.
- Remove the "safety key" and store it in a safe place when the treadmill is not in use. Keep the "safety key" away from children.

## PRECAUTIONS

### Pour réparations futures ou questions connexes :

Please staple your receipt and/or write in the name and phone number of the retail store where you purchased your treadmill.

Name: \_\_\_\_\_ Phone Number: \_\_\_\_\_ Receipt: \_\_\_\_\_

### Précautions:

**AVERTISSEMENT** : Pour réduire les risques de brûlures, d'incendie, de choc électrique ou de blessures aux personnes, lire les précautions importantes et l'information suivantes avant de se servir du tapis roulant. Il revient au propriétaire de s'assurer que tous les utilisateurs de ce tapis ont bien été informés de tous les avertissements et précautions.

- Utiliser le tapis seulement comme il est décrit dans ce manuel.
- Le placer sur une surface plane, en laissant 2X1m d'espace libre en arrière. Ne pas placer le tapis roulant sur une surface qui bloque les ouvertures d'air.
- Pour protéger le plancher ou un tapis de dommages, placer un petit tapis sous le tapis roulant.
- Choisir pour le tapis roulant un emplacement et une position qui permettent d'avoir accès à une prise murale.
- Garder le tapis roulant à l'intérieur, à un endroit sans humidité ni poussière. Ne pas mettre le tapis roulant dans un garage, sur une terrasse couverte ou près de l'eau.
- Ne pas faire fonctionner le tapis roulant pendant la vaporisation de produits aérosol ou l'administration d'oxygène.
- Ne pas laisser les enfants de moins de 12 ans et les animaux s'approcher du tapis roulant.
- Le tapis roulant ne doit pas être utilisé par des personnes pesant plus de **160 kg (350 lb)**.
- Il ne doit jamais y avoir plus d'une personne sur le tapis à la fois. Porter des vêtements d'exercice appropriés pour utiliser le tapis roulant. Ne pas porter de vêtements lâches qui pourraient être pris dans le tapis roulant. Les vêtements de soutien athlétiques sont recommandés tant pour les hommes que pour les femmes. Porter toujours des chaussures d'athlétisme. Ne pas être pieds nus, ou porter seulement des chaussettes ou des sandales lors de l'utilisation du tapis roulant.
- Brancher le cordon d'alimentation dans un circuit avec mise à la terre. Aucun autre appareil ne doit être sur le même circuit.
- Toujours enjamber le tapis et le laisser commencer à rouler avant de monter dessus.
- Toujours examiner votre tapis roulant avant de l'utiliser pour s'assurer que toutes les pièces fonctionnent correctement.
- Laisser le tapis s'arrêter complètement avant de descendre.
- Ne jamais insérer d'objets ou de parties du corps dans une ouverture.
- Suivre les directives de sécurité en ce qui concerne le branchement de votre tapis roulant.
- Garder le cordon d'alimentation éloigné des roues inclinées et ne pas faire passer le cordon d'alimentation sous votre tapis roulant. Ne pas faire fonctionner le tapis roulant si le cordon d'alimentation est endommagé ou effiloché.
- Débrancher toujours le tapis roulant avant de le nettoyer ou de le réparer.
- Toute réparation au tapis doit être effectuée par un réparateur agréé, à moins d'autorisation ou de directives contraires du fabricant. Le non-respect de ces instructions annulera la garantie du tapis roulant.
- Ne jamais laisser le tapis roulant sans surveillance lorsque la clé de sécurité est insérée.
- Utiliser la « clé de sécurité » pour faire fonctionner le tapis roulant et s'assurer qu'elle est accrochée aux vêtements des utilisateurs.
- Retirer la « clé de sécurité » et la ranger dans un endroit sûr lorsque le tapis roulant n'est pas en fonction. Garder la « clé de sécurité » hors de la portée des enfants.

## POWER REQUIREMENTS

### Power Requirements:

IMPROPER CONNECTION OF THE EQUIPMENT GROUNDING CONNECTOR CAN RESULT IN THE RISK OF AN ELECTRIC SHOCK. CHECK WITH A QUALIFIED ELECTRICIAN OR SERVICE MAN IF YOU ARE IN DOUBT AS TO WHETHER THE PRODUCT IS PROPERLY GROUNDING. DO NOT MODIFY THE PLUG PROVIDED WITH THE PRODUCT, IF IT WILL NOT FIT THE OUTLET; HAVE A PROPER OUTLET INSTALLED BY A QUALIFIED ELECTRICIAN.

This treadmill can be seriously damaged by sudden voltage changes in your home's electrical power. Voltage spikes, surges and noise interference can result from weather conditions or from other appliances being turned on or off. To reduce the possibility of treadmill damage, always use a surge protector (not included) with your treadmill.

Surge protectors can be purchased at most hardware stores. The manufacturer recommends a single outlet surge protector with a UL 1449 rating as a Transient Voltage Surge Suppressor (TVSS) with a UL suppressed voltage rating of 400V or less and an electrical rating 120VAC, 15 amps.

This treadmill must be grounded to reduce the risk of electrical shock. Grounding provides a path of least resistance for electric current, should the treadmill malfunction. This treadmill is equipped with an electrical cord that has an equipment-grounding conductor and a grounding plug. Always plug the power cord into a surge protector, and plug the surge protector into an appropriate outlet that is properly installed and grounded in accordance with all local codes and ordinances.

This product is for use on a nominal 120-volt circuit, and has a grounding plug that looks like the plug illustrated in the drawing below.

GFCI outlets and GFCI / AFCI Circuit Breakers are NOT recommended for use on this product. GFCI outlets and GFCI / AFCI Circuit Breakers may cause this equipment to function improperly.

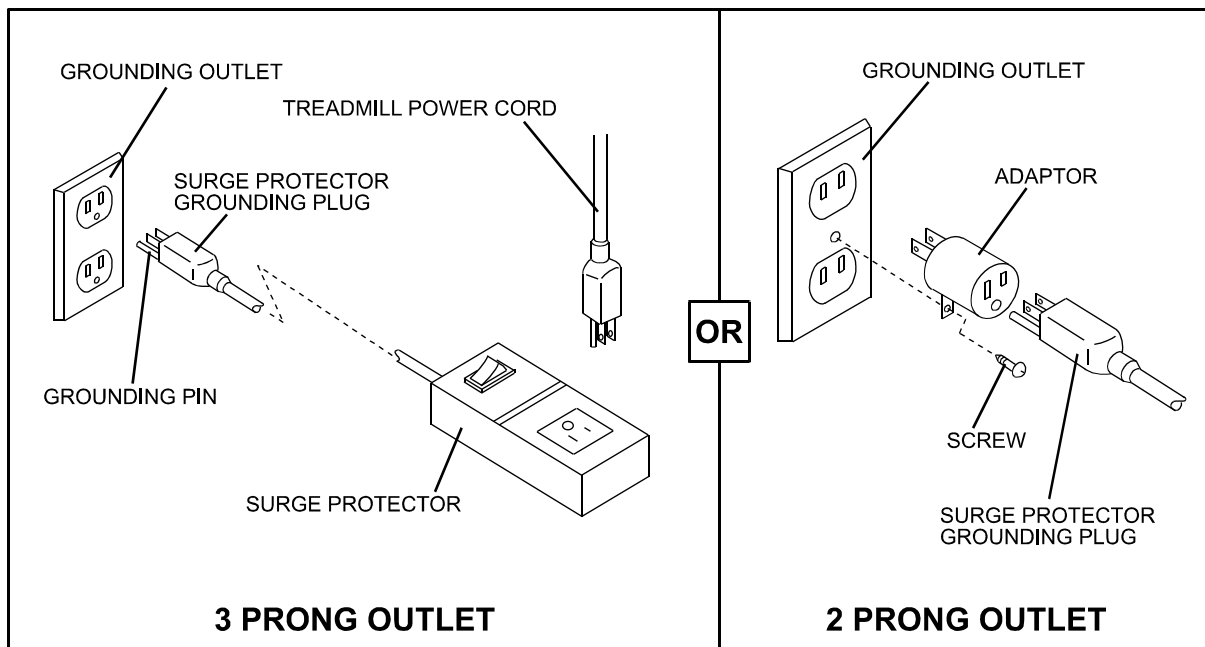

## POWER REQUIREMENTS

### Alimentation :

UN MAUVAIS BRANCHEMENT DU CONNECTEUR DE MISE À LA TERRE DE L'ÉQUIPEMENT POURRAIT PROVOQUER UN CHOC ÉLECTRIQUE. EN CAS DE DOUTE, CONSULTER UN ÉLECTRICIEN OU UN RÉPARATEUR QUALIFIÉ POUR SAVOIR SI LE PRODUIT EST CORRECTEMENT MIS À LA TERRE. NE PAS MODIFIER LA FICHE FOURNIE AVEC LE PRODUIT. SI ELLE N'ENTRE PAS DANS LA PRISE, FAIRE INSTALLER UNE PRISE APPROPRIÉE PAR UN ÉLECTRICIEN PROFESSIONNEL.

Ce tapis roulant pourrait être gravement endommagé en cas de changement soudain de tension dans votre alimentation électrique. Les conditions météorologiques ou la mise sous tension ou hors tension d'autres appareils électriques peuvent provoquer des pointes de tension, des surtensions ou un brouillage. Pour réduire la possibilité que le tapis soit endommagé, toujours utiliser un limiteur de surtension (non inclus) avec votre tapis roulant.

Il est possible d'acheter des limiteurs de surtension dans la plupart des quincailleries. Le fabricant recommande un limiteur de surtension UL 1449 à prise unique comme suppresseur de tension transitoire (TVSS) ayant un taux de suppression de tension de 400 V ou moins et une tension électrique de 110 V C.A., 15 A.

Ce tapis roulant doit être mis à la terre pour réduire le risque de choc électrique. La mise à la terre fournit une voie de moindre résistance au courant électrique en cas de mauvais fonctionnement du tapis roulant. Ce tapis roulant est équipé d'un cordon électrique avec un conducteur de mise à la terre et une fiche de mise à la terre. Brancher toujours le cordon électrique dans un limiteur de surtension et brancher le limiteur de surtension dans une prise appropriée, correctement installée et mise à la terre conformément à tous les codes locaux et ordonnances.

Ce produit doit être utilisé avec un circuit nominal de 110 volts et à une fiche de mise à la terre qui ressemble à celle illustrée ci-dessous.

Les prises avec disjoncteur de fuite de terre et les disjoncteurs de fuite de terre ne sont PAS recommandés pour ce produit. Les prises avec disjoncteur de fuite de terre et les disjoncteurs de fuite de terre pourraient provoquer un mauvais fonctionnement de cet équipement.

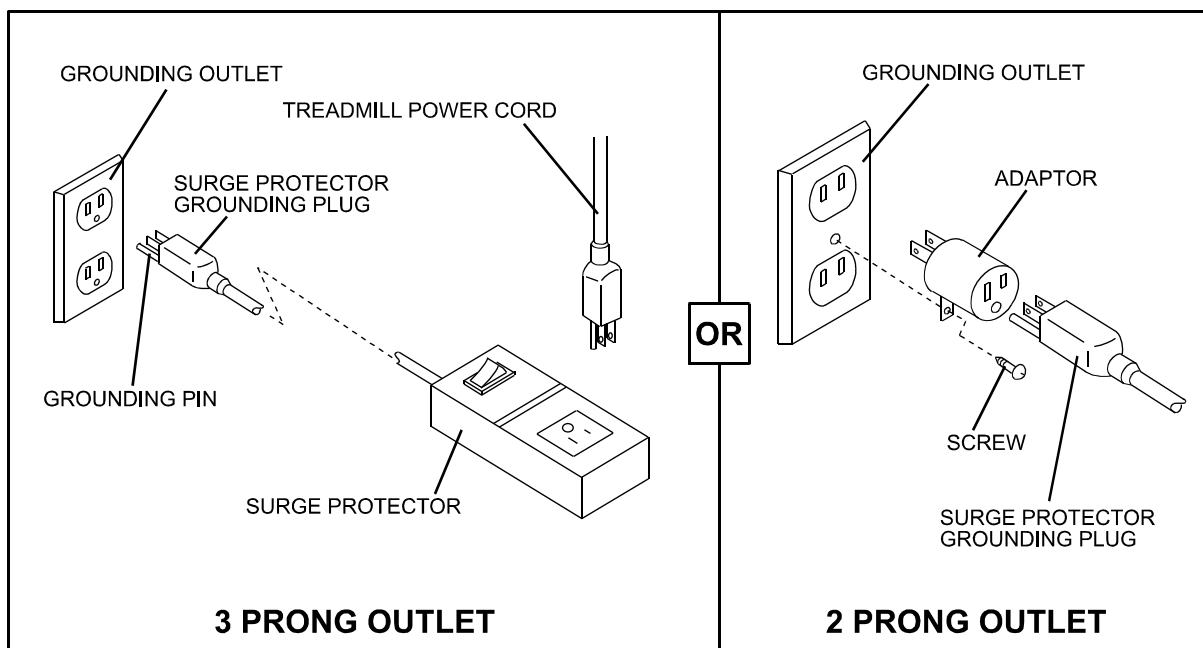

## BEFORE YOU BEGIN

### Open the boxes:

Open the boxes of your new equipment. **Inventory all parts included in the boxes, and Supplied Hardware lists on page 7 for a full count of the parts included.** If you are missing any parts or have any questions contact us directly at 888-800-1167

### Gather your tools:

Before you begin, make sure that you have gathered all the necessary tools you may require to assemble the unit properly. Having all of the necessary equipment at hand will save time and make the assembly quick and hassle-free.

### Clear your work area:

Make sure that you have cleared away a large enough space to properly assemble the unit. Make sure the space is free from anything that may cause injury during assembly. After the unit is fully assembled, make sure there is a comfortable amount of free area around the unit for unobstructed operation.

### Invite a friend:

Some of the assembly steps may require heavy lifting. It is recommended that you obtain the assistance of another person when assembling this product.

### User Weight Limitation:

Please note that there is a weight limitation for this product. If you weigh more than 350LBS (Approx. 160 Kgs). It is not recommended that you use this product. Serious injury may occur if the user's weight exceeds the limit shown here. This product is not intended to support users whose weight exceeds this limit.

### Care and maintenance:

The safety level can be maintained only if it is examined for damage and wear.

Replace any defective components immediately and stop all use of the equipment until repaired.

Always take care when mounting the equipment. Straddle the equipment by placing your feet on the straddle rails. Dismount from the equipment only after all parts have stopped.

Always check the wear and tear components like pulley, belts, etc....To prevent injury.

There is an emergency stop, in the form of a SAFETY KEY, to prevent injury; you can stop the treadmill immediately by actuating the emergency stop for emergency dismount.

**SUPPLIED COMPONENTS / SUPPLIED HARDWARE**

This list identifies the major components you will use to assemble this product.

No.	Description	Qty.
A1	Treadmill Base	1
A2	Console Assembly	1
735i -301	Right Upright	1
735i -302	Left Upright	1
735i -307	Right Handle Bar	1
735i -308	Left Handle Bar	1
735i -310	Right Protective Cover	1
735i -311	Left Protective Cover	1
<b>Hardware Kit</b>		
735i -303	M8x15mm Bolt	14
735i -304	M8 Curve Washer	14
735i -305	M4x15mm Bolt	2
735i -306	M6x15mm Bolt	2
735i -312	M6x65mm Bolt	2
A	5mm Allen Key	1
B	6mm Allen Key	1
735i -209	Safety Key	1
C	Silicone Lubricant	1
735i -309	End cap	4
735i -313	M4x10mm Bolt	4

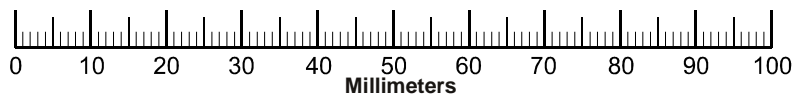
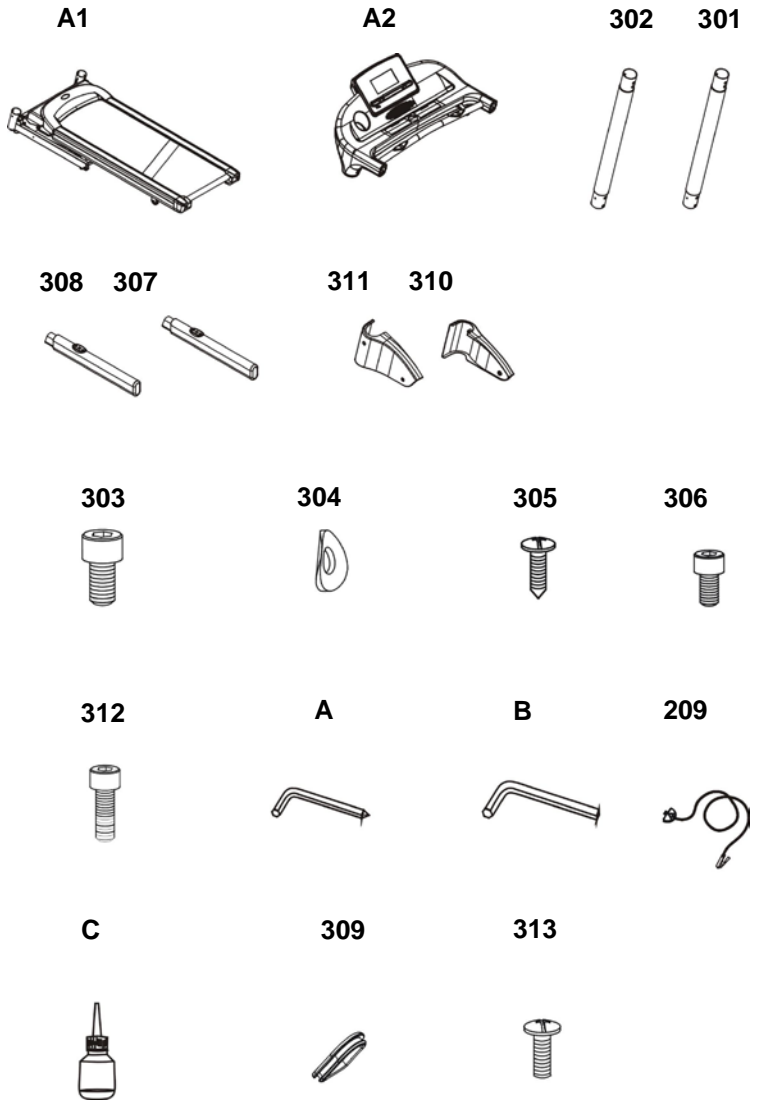

## COMPLETE PARTS LIST

Item No.	Description	Qty.
<b>735i -100</b>		
735i -101	Running deck frame	1
735i -102	Front roller	1
735i -103	Rubber cushion	8
735i -104	Running deck	1
735i -105	Running belt	1
735i -106	Rear roller	1
735i -107	Motor control board	1
735i -108	Upper motor cover	1
735i -109	Fixing bracket, motor	1
735i -110	Bolt M4*15mm	2
735i -111	Front mobile wheel	2
735i -112	Bolt M4*10mm	8
735i -113	Base frame	1
735i -114	Speed sensor	1
735i -115	On-off switch	1
735i -116	Bolt M8*30mm	2
735i -117	Power breaker	1
735i -118	End cap-2	2
735i -119	Running deck frame end cap	2
735i -120	Spring washer M8	2
735i -121	Drive belt	1
735i -122	Left roller cover	1
735i -123	Right roller cover	1
735i -124	Side rein	2
735i -125	Stud-1	2
735i -126	Washer, stud	2
735i -127	Bolt M8*15mm	2
735i -128	Bushing	4
735i -129	Lower locking tube	1
735i -130	Upper locking tube	1
735i -131	Lower motor cover	1
735i -132	Rear wheel	2
735i -133	Spacer	2
735i -134	Incline motor	1
735i -135	DC motor	1
735i -136	Lift arm	1
735i -137	Adjustment pad	2
735i -138	Bolt M8*15mm	2
735i -139	Bolt M3*6mm	2
735i -140	Bolt M8*40mm	2



**COMPLETE PARTS LIST**

tem No.	Description	Qty.
735i -141	Bolt M8*40mm	3
735i -142	Nut M8	2
735i -143	Bolt M10*45mm	1
735i -144	Nut M10	1
735i -145	Spring washer M8	5
735i -146	Bolt M8*15mm	2
735i -147	Horizontal adjustment	2
735i -148	Bolt M8*140mm	1
735i -149	Nut M8	5
735i -150	Bolt 5/16"*135mm	1
735i -151	Lower console wire	1
735i -152	Spring washer M8	1
735i -153	Bolt M4*10mm-1	8
735i -154	Bolt M4*10mm-2	4
735i -155	Power cord	1
735i -156	Washer, stud	2
735i -157	Bolt M8*40mm	2
735i -158	Bolt M8*70mm	3
735i -159	Electric wire cover	1
735i -160	Stud-2	2
735i -161	Wire clip	4
735i -162	Bolt M5*12mm	4
735i -163	Air shock	1
735i -164	Bolt M8*15mm	2
735i -165	Bolt M8*55mm	1
735i -166	Bolt M8*60mm	1
735i -167	Adaptor	1

## COMPLETE PARTS LIST

Item No.	Description	Qty.
<b>735i -200</b>		
735i -201	Console frame	1
735i -202	Console housing	1
735i -203	Bolt M4*10mm	6
735i -204	Handle pulse sensor	2
735i -205	Bolt M4*25mm	2
735i -206	IHP	1
735i -207	Console cover	1
735i -208	Tablet Shelf	1
735i -209	Ring core	1
735i -210	Safety key	1
735i -211	Bolt M3*8mm	18
735i -212	Operational button & overlay	1set
735i -213	Audio jack	1
735i -214	Panel, console	1
735i -215	Bolt M3*6mm	13
735i -216	Bolt M4*10mm	4
735i -217	Speaker	2
735i -218	Speaker fixer	2
735i -219	Handle grip foam	2
735i -220	Handle button cover	2
735i -221	Bolt M4*12mm	4
735i -222	Safety key base	1
735i -223	Bolt M3*6mm	4
735i -224	Lower console cover	1
735i -225	Bottle Holder	1
735i -226	Bolt M3*6mm	2
735i -227	Bolt M4*12mm	14
735i -228	Bolt M3*10mm	2
735i -229	Console wire	1
735i -230	USB charger	1
735i -231	Handle button sticker	2
735i -232	Hand pulse wire	1
735i -233	Handle button wire	2
735i -234	Receiver wire	1
735i -235	Receiver	1
735i -236	Software update cap	1
735i -237	-	-
735i -238	Tablet left support	1
735i -239	Table right support	1
735i -240	Spring	2
735i -241	M4 washer	2
735i -242	Washer	2
735i -243	Bolt M2.6*8mm	2
735i -244	Adaptor wire	1

**COMPLETE PARTS LIST**

Item No.	Description	Qty.
<b>735i -300</b>		
735i -301	Right upright	1
735i -302	Left upright	1
735i -303	Bolt M8*15mm	14
735i -304	M8 curve washer	14
735i -305	Bolt M4*15mm	2
735i -306	Bolt M6*15mm	2
735i -307	Right handle bar	1
735i -308	Left handle bar	1
735i -309	End cap	4
735i -310	Right protective cover	1
735i -311	Left protective cover	1
735i -312	Bolt M6*65mm	2
735i -313	Bolt M4*10mm	4
<b>735i -400</b>		
735i -401	Fan	1
735i -402	Fan cover	1
735i -403	Bolt M3*30mm	4
735i -404	Bolt M3*8mm	4

PARTS DIAGRAM

MOST OF THE PARTS SHOWN HERE HAVE BEEN PRE-ASSEMBLED

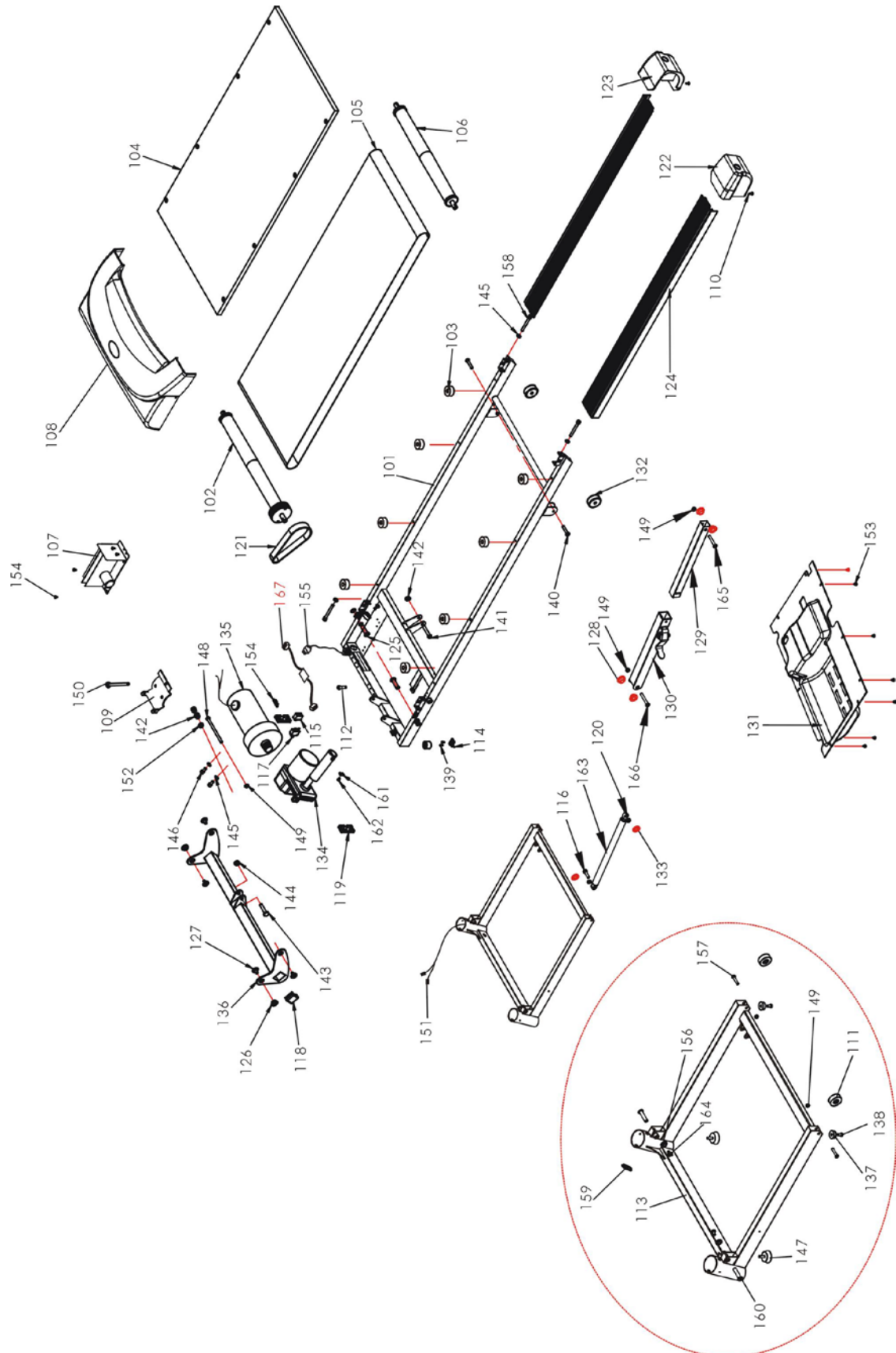

# PARTS DIAGRAM

MOST OF THE PARTS SHOWN HERE HAVE BEEN PRE-ASSEMBLED.

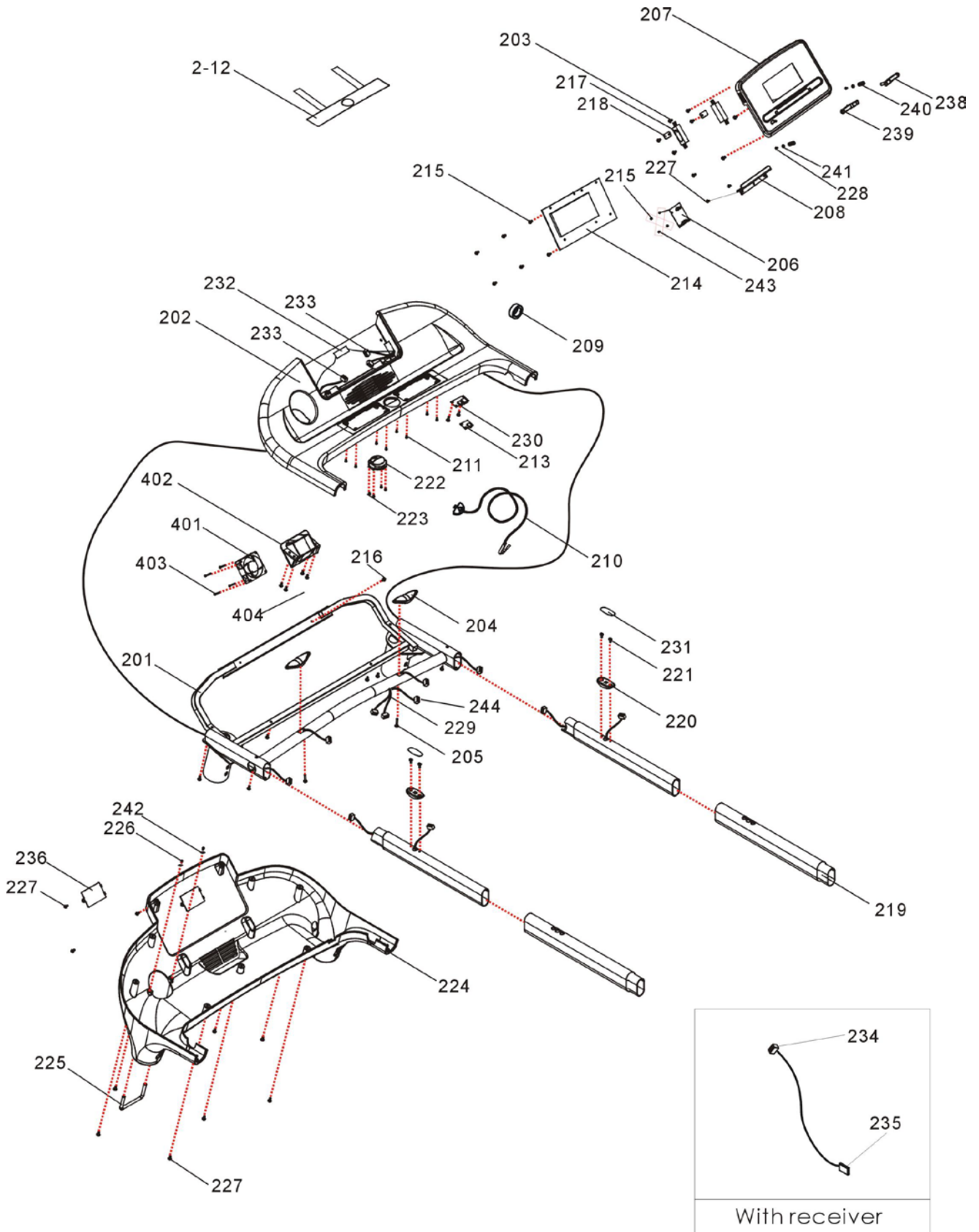

### PARTS DIAGRAM

A MAJORITY OF THE PARTS SHOWN HERE HAVE BEEN PREASSEMBLED AT THE FACTORY.

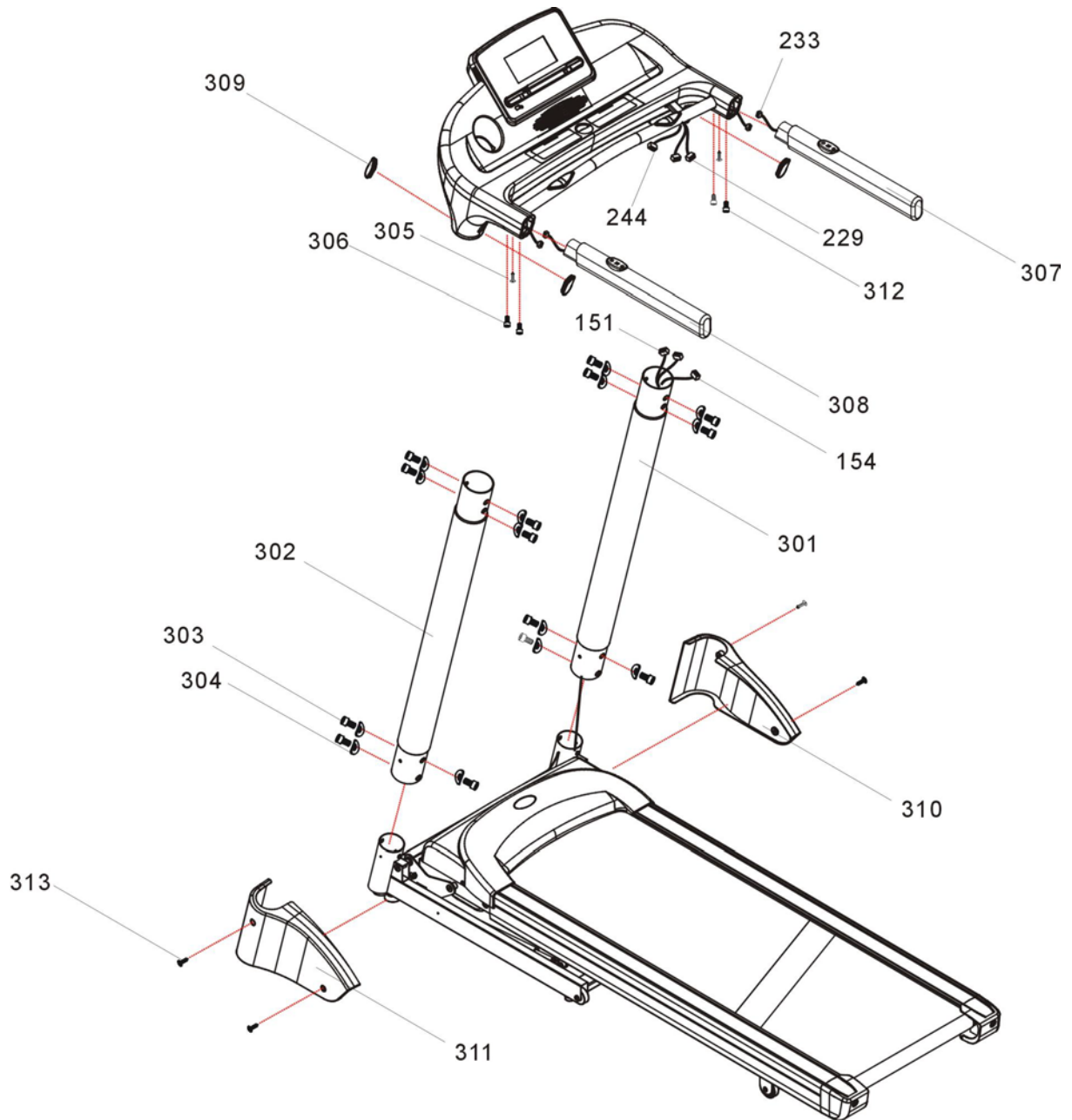

**ASSEMBLY – PLEASE READ ALL STEPS BEFORE BEGINNING YOUR WORK.****STEP1: Assemble Console Mast to Base Frame.**

**NOTE: Make sure all wires are recessed into the frame. DO NOT trap or pinch. DO NOT tighten any bolts until STEP2.**

When attaching the **Right** upright (301) first attach the Lower Console Wire to the fish wire in the upright. This will allow you to pull the data cable up through the upright during installation.

1). Attach Left and Right Uprights into base frame, and secure using 6 x M8x15mm Bolt (303) AND 6 x M8 Curve Washer (304).

**Note: Hand tighten only do not fully tighten the bolts until step 2 is complete.**

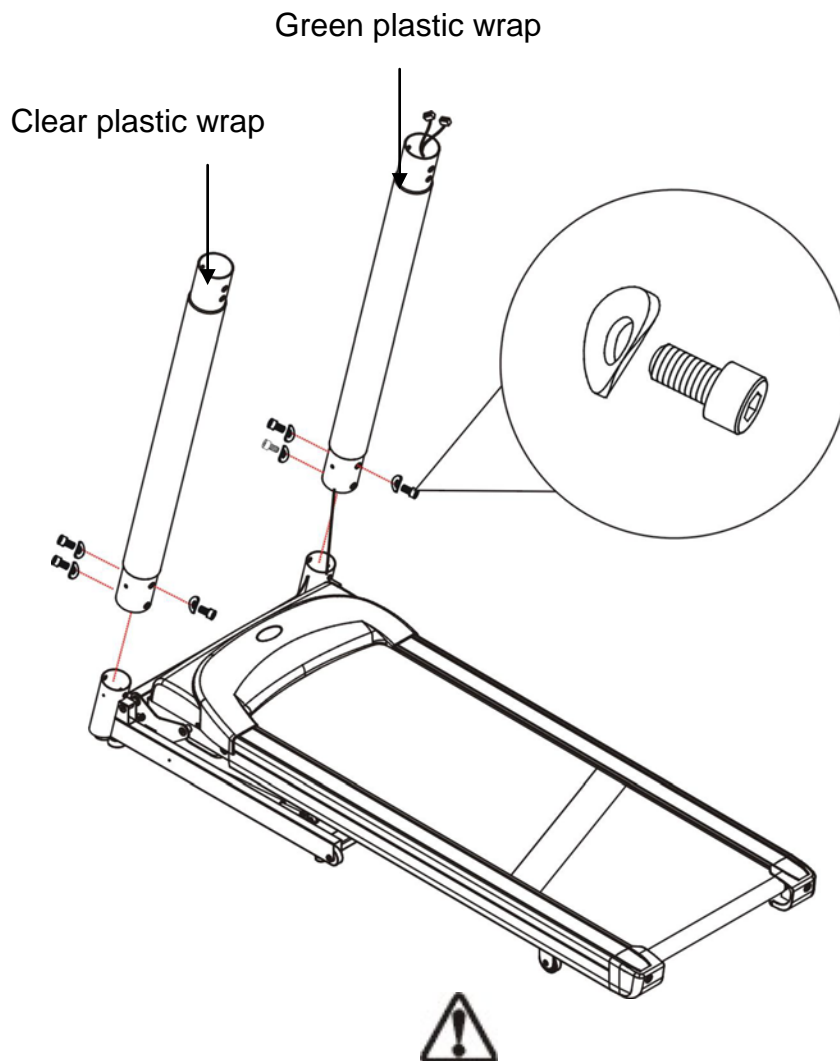
**303****X6****304****X6**

Bolts should be hand tight only

**ASSEMBLY – PLEASE READ ALL STEPS BEFORE BEGINNING YOUR WORK.****STEP 2: Attach Console to Left and Right Uprights**

1). Connect the Upper Console Wire (229) from the console set to Lower Console Wire (151) and Adaptor Wire (244 to 154) in the right upright, Then place the excess wire and the connectors into right upright.

2). Place the entire console set onto the uprights, and secure the left side using 4 x M8x15mm Bolt (303) with 4 x M8 Curve Washer (304).

3). Repeat the above process for the Right side.

4). Fully tighten all bolts from step 1 and step 2.

**303****X8****304****X8**

**Caution Pinch point! Do not pinch wires between frame.**

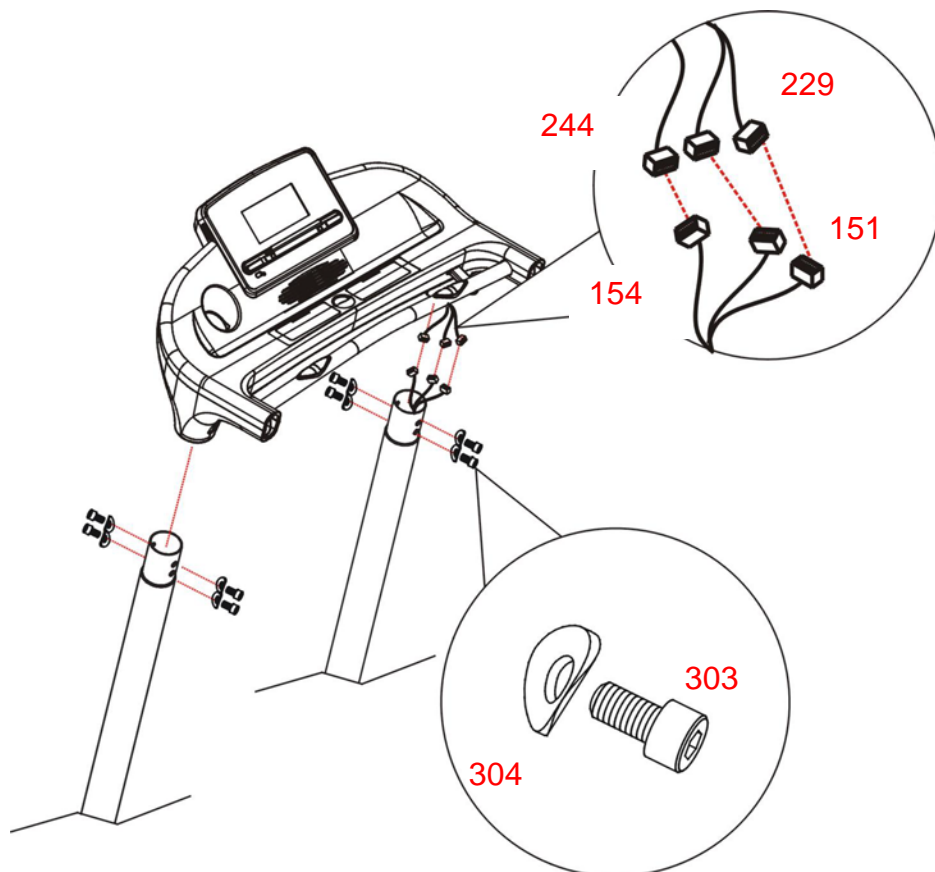



**ASSEMBLY****STEP 3: Attach the Handle Bars**

- 1). Take out right handle bar from the carton, connect the handlebar button wire  
The excess wire must be placed inside the console frame after connecting the wires to prevent pinching the wire as the wire might be pinched or damaged
- 2). Attach the right and left handle bar and secure using the 2xM4x15mm bolt (305) with 2xM6x15mm bolt (306) and 2xM6x65mm bolt (312).

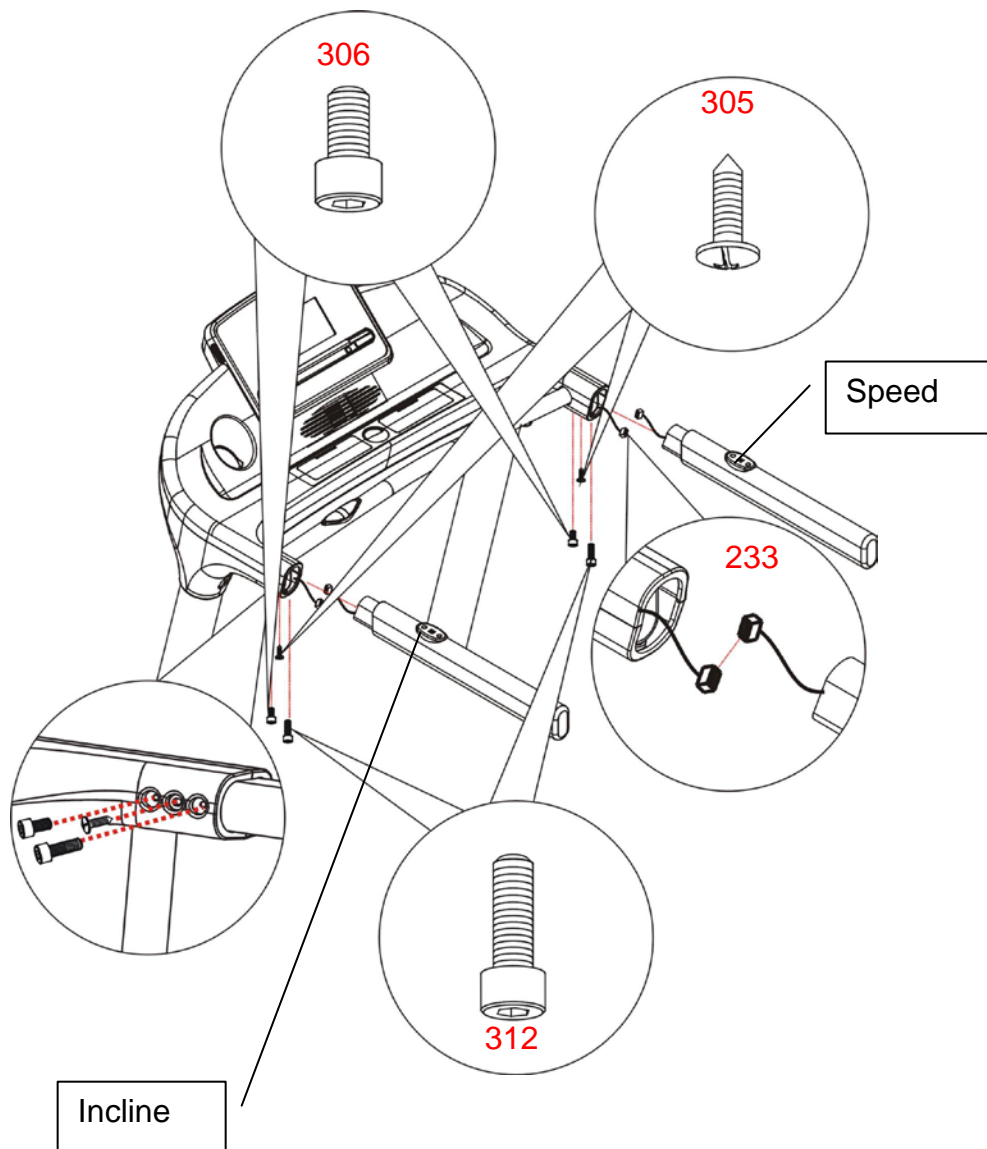
**305****X2****306****X2****312****X2**

 Tighten all bolts and fasteners now

**ASSEMBLY**

**Step4: Attach the console to the console mast**

1). Put 4 plastic caps (309) into console lower cover.

**309 X4**

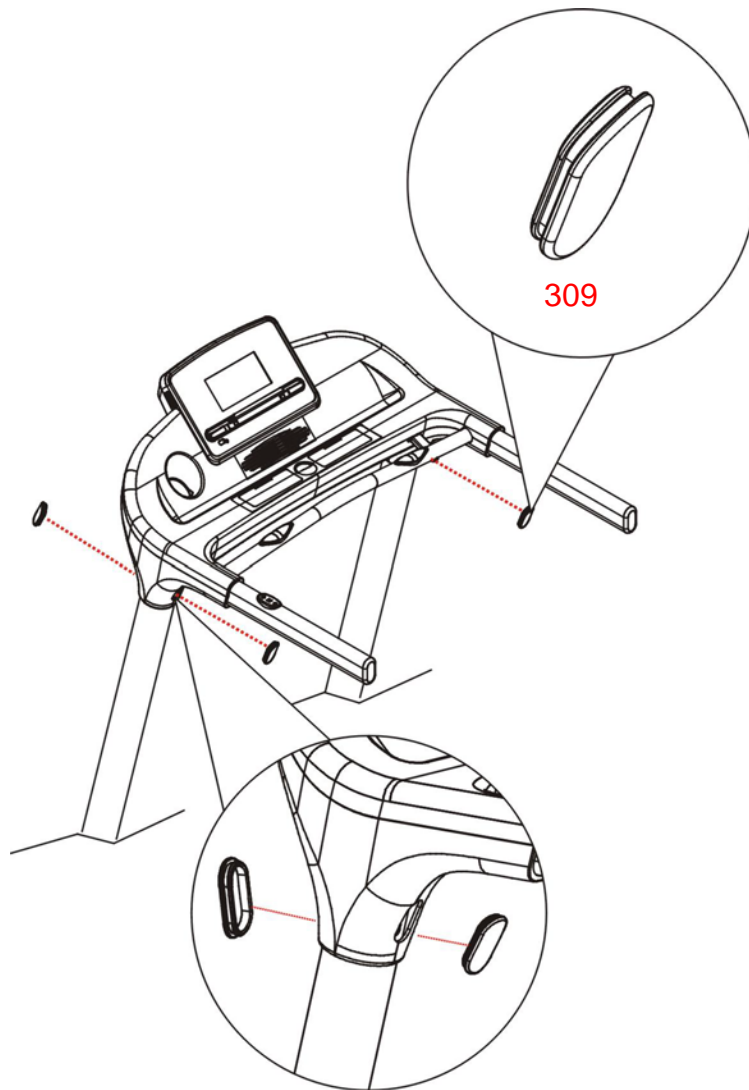

**ASSEMBLY****STEP 5: Attach the upright covers onto the uprights**

- 1). Attach the Left Upright Cover (311) onto the Left upright and secure using 2 x M4x10mm Bolt (313).
- 2). Repeat the above process for the Right side

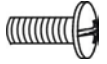
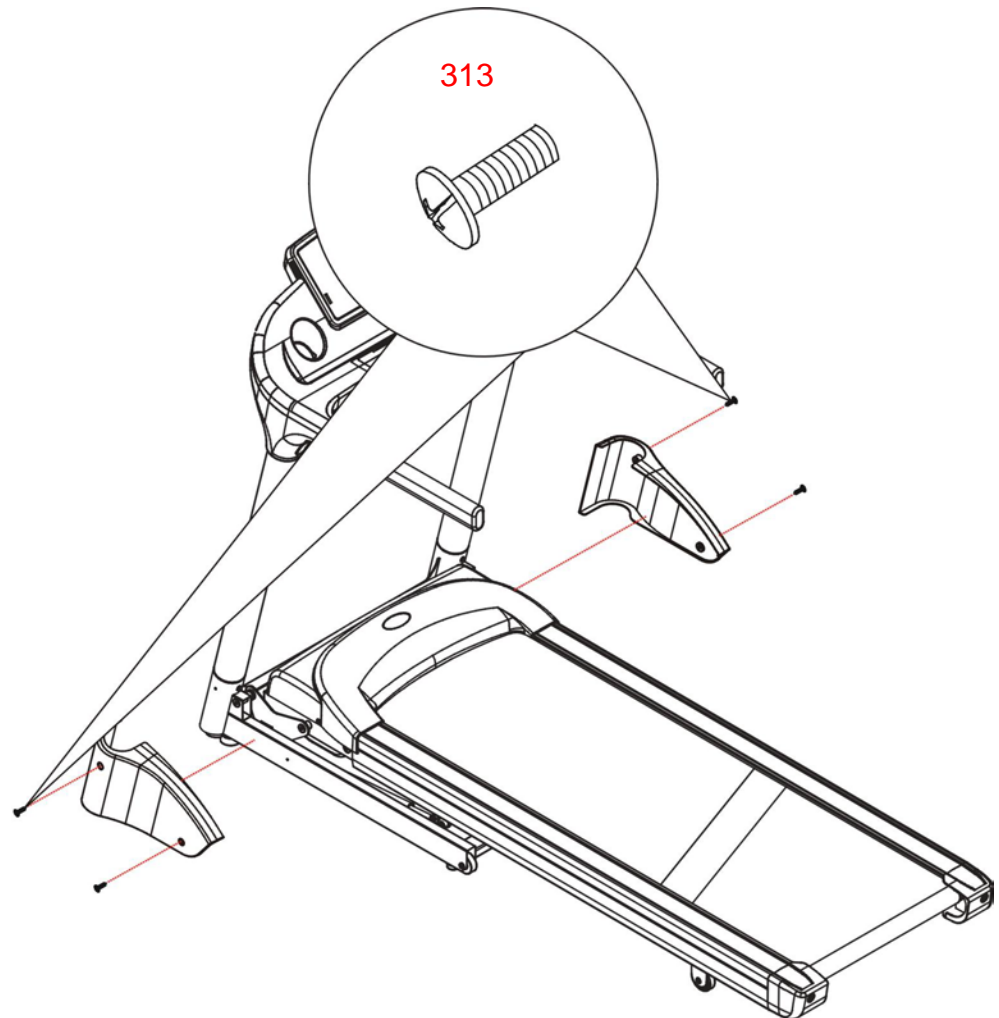
**313 X4****311 310**

**ASSEMBLY**

**STEP 6:**

Insert Safety Key (209) into Bottom Center of Console prior to operation. Your treadmill will not Function with out the safety key.

**209 X1**

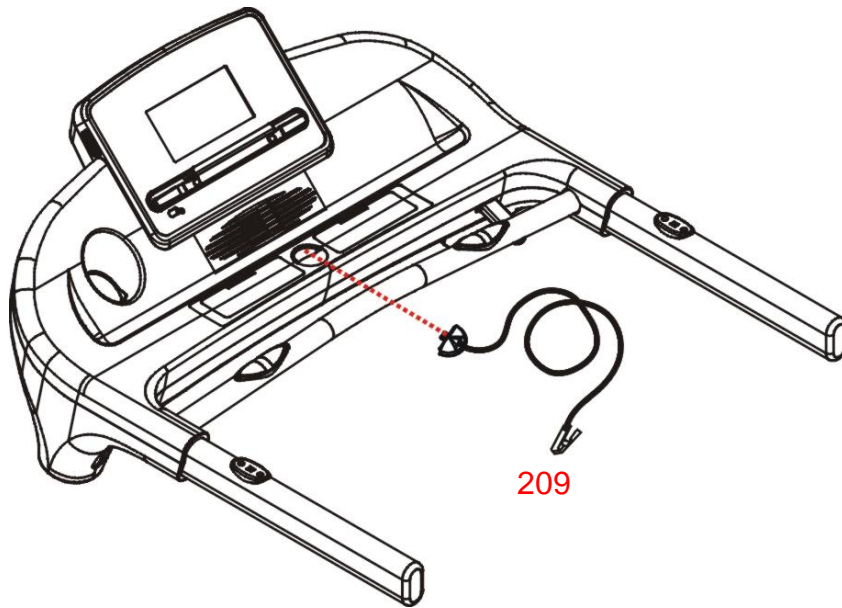

## ASSEMBLY

### How to fold and unfold the treadmill:

Your treadmill can be folded up and unfold for space saving storage. To do this follow the instructions here:

#### Fold Up

1. To fold the deck you first need to bring the treadmill to the lowest incline level and then remove the power cord
2. Lift the deck up from the rear of the treadmill and fold up until it locks in place. **TO PREVENT INJURY BE SURE YOU HAVE A FIRM HOLD WHEN RAISING THE DECK.**
3. You will hear a "click" sound as the lock engages.

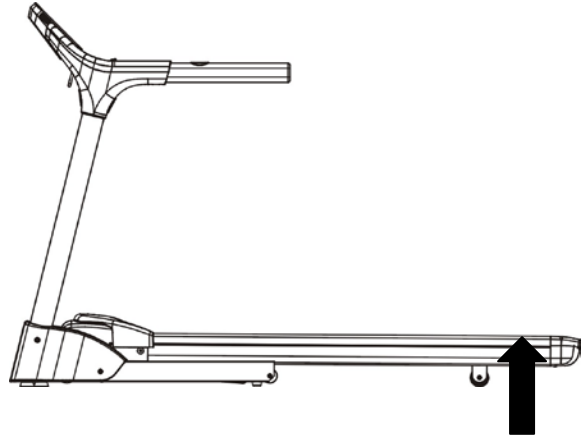

#### Unfold

You can unfold the treadmill from the upright position:

1. Begin by standing behind and supporting the deck with your hands. Next release the lock with your foot by stepping on the release lever. **TO PREVENT INJURY BE SURE YOU HAVE A FIRM HOLD ON THE DECK BEFORE RELEASING THE LOCK.**
2. Slowly lower the deck certain angle till the deck start to lower by itself. The deck will lower slowly till it rests securely on the ground. **PLEASE DO NOT STAND ON THE AREA WHERE UNDERNEATH THE DECK WHEN THE DECK LOWERING.**

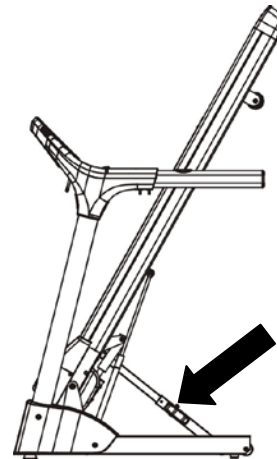

#### Horizontal Adjustment

An uneven floor or improper stabilizer level can cause the treadmill to wobble during use as well as the incline adjustment to function incorrectly. Please follow the procedure described below to make sure the treadmill stabilizer is adjusted correctly prior to use. You may need the assistance of another person to perform this adjustment.

**First locate the two adjustable stabilizers under the base frame. Then simply rotate them in or out to adjust the level of the treadmill. When properly adjusted the treadmill should sit firmly on both stabilizers and all cushions.**

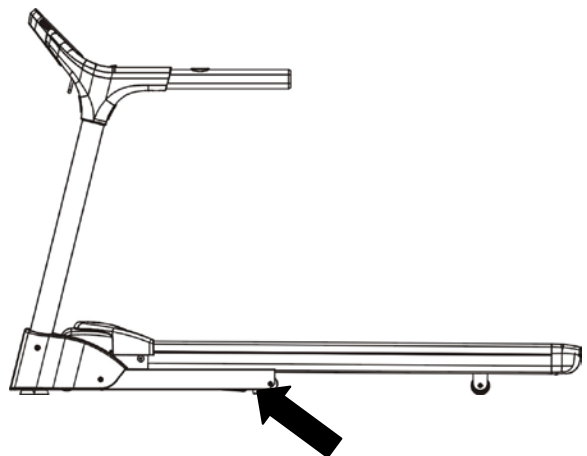

## MAINTAINENCE

### HOW TO MAINTAIN YOUR TREADMILL:

Proper maintenance is very important to ensure your treadmill is always in top working condition. Improper maintenance could cause damage or shorten the life of your treadmill and exceed the LIMITED WARRANTY coverage.

- **Important: DO NOT** use abrasives or solvents to clean the treadmill. To prevent damage to the computer, keep liquids away and keep it out of direct sunlight.
- Inspect and tighten all parts of the treadmill regularly. Replace any damaged or worn parts immediately.

### BELT ADJUSTMENT:

The running belt has been properly adjusted at the factory. However transportation, uneven flooring or other unpredicted reasons could cause the belt to shift off center resulting in the belt rubbing with the plastic side rail or end caps and possibly causing damage. To adjust the belt back to it's proper position please follow the directions below:

1. If your belt tends to walk to the right, rotate the right tension bolt clockwise. We recommend adjustments of 1/4 turn at a time, and follow with a test. If your belt continues to walk to the right, simply adjust the left belt tension bolt by turning it 1/4 turn counterclockwise, and follow with a test.
2. If your belt tends to walk to the left, rotate the left tension bolt clockwise 1/4 turn at a time, and follow with a test. If the belt continues to walk to the left, simply adjust the right tension bolt counterclockwise.
3. If your belt appears to be loose, simply tighten both bolts evenly 1/4 turn. If it appears tight, simply loosen both bolts evenly 1/4 turn.

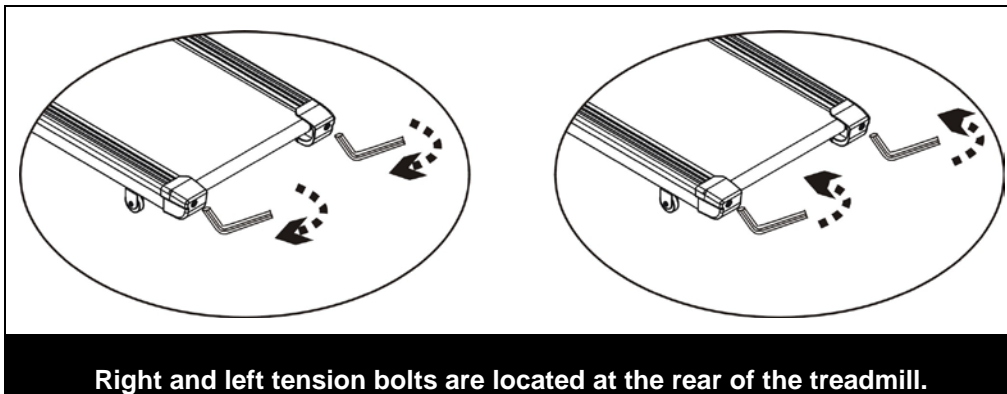

### DECK LUBRICATION:

The walking belt has been pre-lubricated at the factory. However, it is recommended that the walking board be checked periodically for lubrication to ensure optimal treadmill performance. Your treadmill should not have to be lubricated usually within 3 months.

Smooth Fitness recommends lubricating the walking deck a minimum of twice a year for light use (2 days a week) and four times a year for heavier use (3 times a week multiple users)

Please visit [www.smoothfitness.com](http://www.smoothfitness.com) for approved maintenance supplies

## MAINTAINENCE

### To apply lubricant under the walking belt:

1. Position the walking belt so that the seam is located on top and in center of the walking board.
2. Insert the nozzle of the lubricant container under the belt
3. While lifting the side of the walking belt, position the nozzle between the walking belt and the board approximately 15 cm (6 inches) from the front of the treadmill. Apply the silicone lubricant to the walking board, moving from the front of the treadmill to the rear. Repeat this on the other side of the belt. Note: it is important to get the lubricant as far to the center of the walking board as possible.
4. Allow the silicone to "set" for 1 minute before using the treadmill.

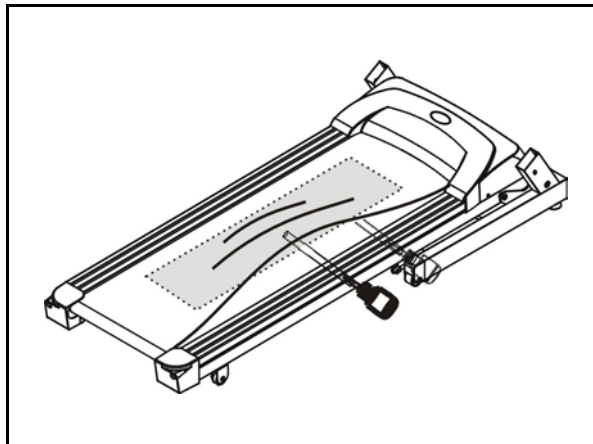

Apply lubricant from front to back.

## CLEANING:

Routine cleaning of your treadmill will extend the product's life.

- **Warning:** To prevent electrical shock, be sure the power to the treadmill is OFF and the power cord is unplugged from the wall electrical outlet before attempting any cleaning or maintenance.
- **Important:** DO NOT use abrasives or solvents to clean the treadmill. To prevent damage to the computer, keep liquids away and keep it out of direct sunlight.
- **After each workout:** Wipe off the console and other treadmill surfaces with a clean, water dampened soft cloth to remove excess perspiration.
- **Weekly:** Use of a treadmill mat is recommended for ease of cleaning. Dirt from your shoes contacts the belt and eventually makes it to underneath the treadmill. Vacuum underneath treadmill once a week.

**Note:** when lubricating the belt, make sure the treadmill is located on a surface that can be easily cleaned. After lubricating your treadmill running belt, clean any excess silicone off the belt and frame.

**IMPORTANT STEPS****Warning:**

Before using this product, please consult your personal physician for a complete physical examination. Frequent and strenuous exercise should be approved by your doctor first. If any discomfort should result from your use of this product, stop exercising and consult your doctor. Proper usage of this product is essential. Please read your manual carefully before exercising.

**Avertissement :**

Avant d'utiliser de produit, veuillez consulter votre médecin personnel pour un examen médical complet. Des exercices fréquents et difficiles doivent d'abord être approuvés par votre médecin. Si vous ressentez un malaise par suite de l'utilisation de produit, arrêtez les exercices et consultez votre médecin. Un usage approprié de ce produit est essentiel. Veuillez lire attentivement votre manuel avant de commencer les exercices.

Les enfants doivent rester éloignés de l'équipement pendant son utilisation et lorsqu'il est laissé sans surveillance. Portez toujours des vêtements appropriés pour les exercices, y compris des chaussures d'athlétisme. Ne portez pas de vêtements amples qui pourraient être pris dans l'appareil durant les exercices.

Please keep all children away from the equipment during use and when equipment is unattended.

Always wear appropriate clothing, including athletic shoes, when exercising. Do not wear loose clothing that could become caught during exercising.

Make sure that all bolts and nuts are tightened when equipment is in use. Periodic maintenance is required on all exercise equipment to keep it in good condition.

**Before beginning:**

How you begin your exercise program depends on your physical condition. If you have been inactive for several years, or are severely overweight, you must start slowly and increase your time gradually, a few minutes per week.

Initially you may be able to exercise only for a few minutes in your target zone. However, your aerobic fitness will improve over the next six to eight weeks. Don't be discouraged if it takes longer. It's important to work at your own pace. Ultimately, you'll be able to exercise continuously for 30 minutes. And the better your aerobic fitness, the harder you will have to work to stay in your target zone. But remember these essentials:

- Contact your physician before starting a workout or training program. Have your doctor review your training and diet programs to advise you of a workout routine you should adopt.
- Begin your training program slowly with realistic goals that have been set by you and your doctor.
- Supplement your program with some type of aerobic exercise such as walking, jogging, swimming, dancing and/or bicycling. Monitor your pulse frequently. If you do not have an electronic heart rate monitor, have your physician show you the proper way to manually check your pulse by using your wrist or neck. Establish your target heart rate based on your age and condition.
- Drink plenty of fluids during the course of your routine. You must replace the water content lost from excessive exercising to avoid dehydration. Avoid drinking large amounts of cold liquids. Fluids should be at room temperature when consumed.



## MUSCLE CHART

### Targeted muscle groups:

The exercise routine that is performed on this product will develop primarily lower body muscle groups. These muscle groups are shown in gray color on the chart below.

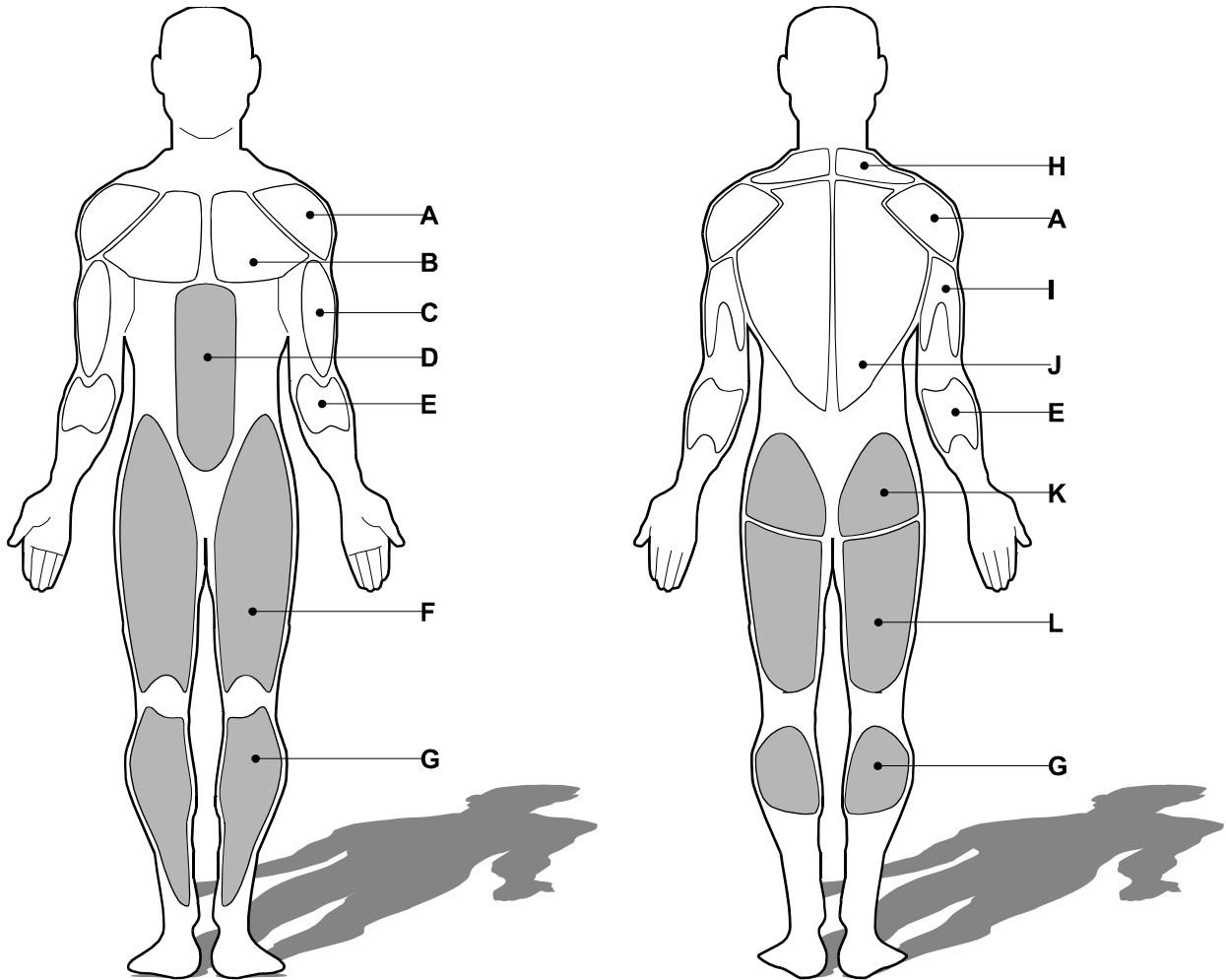

### MUSCLE GROUPS

<b>A</b>	Shoulder muscles	Calf muscles	<b>G</b>
<b>B</b>	Pectoral muscles	Trapezius muscles	<b>H</b>
<b>C</b>	Bicep muscle	Tricep muscles	<b>I</b>
<b>D</b>	Abdominal muscles	Back muscles	<b>J</b>
<b>E</b>	Forearm muscles	Gluteal muscles	<b>K</b>
<b>F</b>	Quadricep muscles	Hamstring muscles	<b>L</b>

## STRETCHING ROUTINE

### Warm up and cool down:

A successful exercise program consists of a warm-up, aerobic exercise, and a cool-down. Do the entire program at least two and preferably three times a week, resting for a day between workouts. After several months, you can increase your workouts to four or five times per week.

Warming up is an important part of your workout, and should begin every session. It prepares your body for more strenuous exercise by heating up and stretching out your muscles, increasing your circulation and pulse rate, and delivering more oxygen to your muscles. At the end of your workout, repeat these exercises to reduce sore muscle problems. We suggest the warm-up and cool-down exercises on the following pages:

### Toe Touch:

Slowly bend forward from your waist, letting your back and shoulders relax as you stretch toward your toes. Reach down as far as you can and hold for 15 counts.

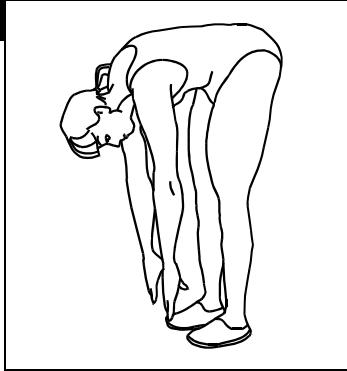

### Shoulder Lift:

Lift your right shoulder up toward your ear for one count. Then lift your left shoulder up for one count as you lower your right shoulder.

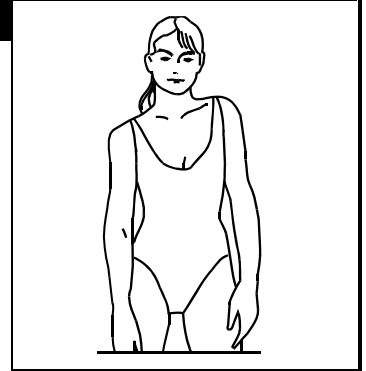

### Inner Thigh Stretch:

Sit with the soles of your feet together with your knees pointing outward. Pull your feet as close into your groin as possible. Gently push your knees towards the floor. Hold for 15 counts.

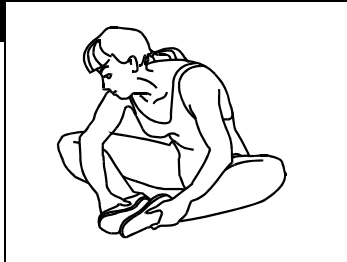

### Hamstring Stretch:

Sit with your right leg extended. Rest the sole of your left foot against your right inner thigh. Stretch toward your toe as far as possible. Hold for 15 counts. Relax and then repeat with left leg extended.

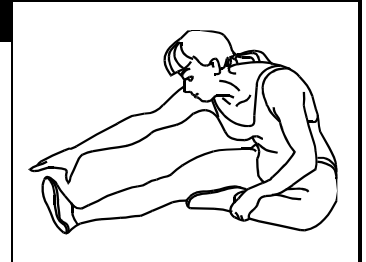

### Side Stretch:

Open your arms to the side and continue lifting them until they are over your head. Reach your right arm as far upward toward the ceiling as you can for one count. Feel the stretch up your right side. Repeat this action with your left arm.

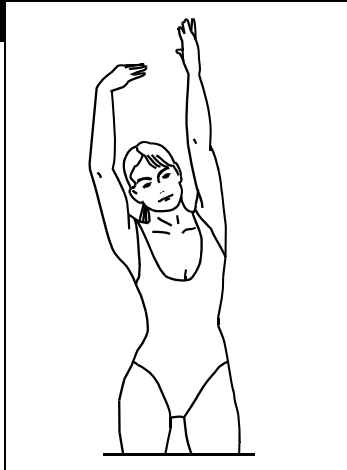

### Calf-Achilles Stretch:

Lean against a wall with your left leg in front of the right and your arms forward. Keep your right leg straight and the left foot on the floor; then bend the left leg and lean forward by moving your hips toward the wall. Hold, and then repeat on the other side for 15 counts.

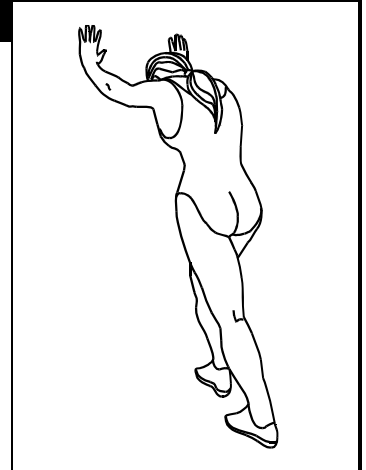

### Head Roll:

Rotate your head to the right for one count, feeling the stretch up the left side of your neck. Next, rotate your head back for one count, stretching your chin to the ceiling and letting your mouth open. Rotate your head to the left for one count, and finally, drop your head to your chest for one count.

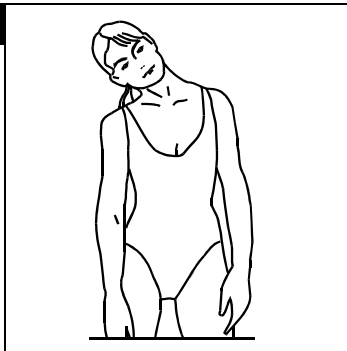

## STRETCHING ROUTINE

### Read carefully the following before using your treadmill

- ◆ Always stretch your muscles before exercise program. Warm up slowly by walking at a slow speed. Increase workout intensity gradually until you reach your desired workout pace. Decrease workout intensity gradually to an easy walk, allowing your heart rate to decrease to a normal situation.
- ◆ When starting the treadmill, always stand with both feet on the step-on side rails.
- ◆ When finishing, allow the running belt to slow down and come to a complete stop before stepping off.
- ◆ Wear comfortable, non-restrictive clothing when using the treadmill. Never wear anything loose, such as baggy sweat pants, neckties, loose socks or jewelry. Never drape towels on or around the treadmill during use.

### WARNING

If you feel dizzy, nausea, chest pain or other abnormal symptoms, stop immediately. Consult a physician before continuing use.

**AVERTISSEMENT:** Si vous vous sentez étourdi, la nausée, la douleur de coffre ou d'autres symptômes anormaux, s'arrêtent immédiatement. Consultez un médecin avant de continuer l'utilisation.

- ◆ Always use the handrail when stepping on or off the treadmill and when changing incline or speed.
- ◆ This treadmill is equipped with a safety key – always clip the cord attached to the safety key to a part of your clothing so the safety key will properly detach from the computer console, thereby stopping the treadmill.
- ◆ Wear running or walking shoes with high-traction soles. To avoid injury and unnecessary wear on your treadmill, be sure your shoes are free of any debris such as gravel and small rocks.

### Before completing an exercise session, always:

1. Allow time to slow your pace, cool down, and reduce your heart rate to a normal level before completing your workout.
2. Grasp the handlebars and press the Speed “?” button. Slow your pace to an easy walk.
3. Ensure the running belt has come to a complete stop before exiting the treadmill.

### WARNING

Turn off and unplug the treadmill before proceeding with any maintenance or visual inspections. Failure to do so may result in serious injury. Note: Failure to perform the required periodic and preventative maintenance can void your warranty.

### AVERTISSEMENT

Arrêtez et débranchez le tapis roulant avant de procéder à tout l'entretien ou inspections visuelles. Le manque de faire ainsi peut avoir comme conséquence des dommages sérieux. Note : Le manque d'exécuter l'entretien périodique et préventif exigé peut vider votre garantie.

### At the end of every exercise session, always:

1. Remove the Safety Key from the computer console.
2. Use the master power switch to turn the treadmill off. The master power switch is located at the right side of frame next to the electrical cord.
3. Always position and store the electrical cord where is clear from all pathways.
4. Unplug the electrical cord from the electrical outlet. This is especially important if you are not going to use your treadmill for extended periods.
5. Wipe all treadmill surfaces with a dry cloth or towel especially perspiration on the handlebars, con troll panel, running belt or other treadmill components.

COMPUTER OPERATION



Congratulations this product is equipped with the MY SMOOTH Virtual Fitness Trainer. Whether you want to lose weight, train for a sporting event, or simply maintain a healthy lifestyle, the MY SMOOTH Virtual Fitness Trainer provides the tools, structure and support you need to be fit and live healthy. The 5 simple steps, outlined in the customer care kit\* are proven to help you lose weight, improve your health, and make positive steps to a healthier lifestyle. These five steps combined with the tools built into your online account, will provide you with a great start toward achieving your goals.

To set up your account, refer to the instructions in the Getting Started Guide contained in your Smooth Fitness customer care kit or visit [www.mysmoothtrainer.com](http://www.mysmoothtrainer.com)

<p><b>Welcome to mySMOOTH!</b></p> <p>Your personal online account will empower you to take control of your health and fitness to achieve your goals.</p> <p>You can truly consolidate all of your exercise activity and your vital statistics in one place; automatically save and log your exercise, weight and blood pressure; and get exercise programs designed just for you.</p> <p>Your USB storage device provides the connection between your mySMOOTH account and the IHP certified products you use. Once your data is in your account, you can view it in a variety of ways that will help motivate you to stick with your exercise program. mySMOOTH is easy to use and proven to help you stay active, lose pounds, or train for a marathon.</p> <p>780 5th Avenue King of Prussia PA, 19406 800-211-1611 <a href="http://www.SmoothFitness.com">www.SmoothFitness.com</a></p> <p>2010 Smooth Fitness. All Rights Reserved</p>	<p><b>1 Create Your Account</b></p> <p><b>1. Enroll</b> It takes only minutes to set up your account.</p> <ol style="list-style-type: none"> <li>Go to <a href="http://www.mysmoothtrainer.com">www.mysmoothtrainer.com</a> and click the <b>Enroll Now</b> button.</li> <li>Follow the online instructions.             <ol style="list-style-type: none"> <li>Enter the enrollment ID shown below.</li> <li>Read and accept the Terms and Conditions, then click continue.</li> <li>Fill out the enrollment form. Make sure you enter a valid and accessible email address.</li> </ol> </li> </ol> <p>After completing the enrollment form, you will be sent an email with your temporary password (check your junk email box if you do not receive it within 10 minutes).</p> <p>Enrollment ID#</p>	<p><b>2. Log In &amp; Enter Your Baseline Vital Stats</b></p> <ol style="list-style-type: none"> <li>To log in to your account, go to <a href="http://www.mysmoothtrainer.com">www.mysmoothtrainer.com</a> and click <b>Member Login</b>. Enter the temporary password emailed to you, and change your password following the on-screen prompts.</li> </ol> <p><b>Health Metrics</b></p> <ol style="list-style-type: none"> <li>Enter your health metrics (at least the stats you know) to establish a baseline of your information. As you use your mySMOOTH membership, you can compare your progress to your baseline.</li> </ol> <p>NOTE: At a minimum, it is important to enter your height and weight. This personal data is used by IHP certified exercise equipment and health monitors to save you time during setup and record accurate data to your USB storage device.</p>	<p><b>3. Set Your Goals</b></p> <p>A critical step in using your mySMOOTH membership is to enter your health and fitness goals.</p> <p>You'll have an 80% higher success rate of achieving your goals if you record them. Specific, attainable goals for exercise, vital stats and behavioral change provide the foundation for your roadmap to success.</p> <p>Your goals are used to develop a plan that's right for you. Later, when you review your results and compare your progress to your goals, you can re-establish your goals and set them even higher.</p>	<p><b>4. Pick a Workout Calendar</b></p> <p><b>Workout Calendar</b></p> <p>Using the information you've already provided, mySMOOTH recommends workout calendars that match your goals, physical condition, and exercise preferences. All workout calendars are developed by experienced Exercise Physiologists to help you receive the maximum benefit from your exercise.</p> <p>Your personalized workout calendar combines cardio, strength, flexibility and balance exercises, and tells you which days to exercise, for how long, and at what level of intensity. YOU choose the physical activities you enjoy, whether indoors, outdoors, at home or at the gym.</p> <p>Your personalized workout calendar provides a structured approach to help you achieve your goals.</p>
<p><b>2 Using Your USB Drive</b></p> <p><b>1. Install Your Communications Software</b></p> <p>If you have a mySMOOTH drive, you must first install the IHP data communicator software on your computer. This allows your computer to recognize the USB drive. This is a quick, one-time process done on each computer you use with your USB drive.</p> <ol style="list-style-type: none"> <li>Click <b>Install Communications Software</b> button at the bottom of your home page.</li> <li>If you are prompted to <b>Open</b> or <b>Save</b> the file, click the <b>Open</b> button. Follow the prompts displayed on the screen.</li> <li>When installation is complete, an IDC icon will be on your desktop (in Windows) or dock (on a Macintosh).</li> </ol> <p>NOTE: Before you use your IHP certified product, make sure the exercise equipment or health monitor has the correct date and time set so your data is accurately recorded (see the product Owner's Manual for details).</p>	<p><b>2. Sync Your Personal Data</b></p> <p>Synchronize your personal data with your USB drive, and upload exercise and health metrics results from your USB into your account.</p> <p>To Sync for the First Time, or When Logged In</p> <ol style="list-style-type: none"> <li>Insert your USB drive into your computer.</li> <li>Log in and click <b>Update Exercise Results</b> or <b>Update Health Metrics</b>, then <b>USB Update</b>.</li> <li>Click <b>Synchronize USB</b>.</li> <li>Enter your Last Name and Password, then click <b>Remember Me and Sign In</b>.</li> <li>Click <b>Select USB Drive</b>, then choose your computer's USB drive (usually E: or G:). Your computer will then recognize your USB and you do not need to perform this step again.</li> <li>Your personal profile, including name, age, height, weight and gender, will sync to your USB drive. Workout data and health metrics, if any on the USB, are uploaded to your account.</li> </ol>	<p><b>To Sync When Not Logged In</b></p> <p>After you've synchronized your USB drive, you can sync your data at any time simply by double-clicking the IDC icon on your desktop and following the on-screen prompts. It's simple and convenient, and doesn't require being logged in to update your results.</p> <p>All IHP certified products work with your mySMOOTH Account</p> <p>When you exercise on IHP certified fitness equipment and use IHP certified health monitors, your results are automatically saved to your USB for easy uploading into your account.</p>	<p><b>3 Enter Your Results Manually</b></p> <p>You can keep track of just about any exercise and health metrics in your mySMOOTH account, whether you have a mySMOOTH USB drive or not! It's simple to log and track all your physical activity - swim, bike outdoors, exercise at the gym, or attend fitness classes. Enter your vital stats as you take them or after you go to the doctor. You'll be rewarded with seeing your exercise results and health improvements in fun and motivating mySMOOTH reports.</p> <ol style="list-style-type: none"> <li>Log in to your account.</li> <li>Click the <b>Update Exercise Results</b> or <b>Update Health Metrics</b>.</li> <li>Follow the simple on-screen prompts.</li> </ol>	<p><b>Online Membership</b></p> <p><b>MY SMOOTH Virtual Fitness Trainer</b></p> <p>BY <b>SMOOTH FITNESS</b></p> <p>Enrollment ID# Included</p>

\*Not all Smooth Fitness products include the Smooth Customer Care Kit

# COMPUTER OPERATION

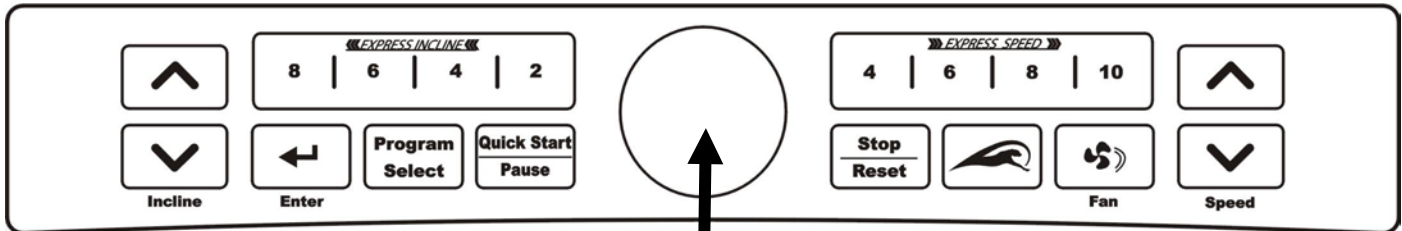
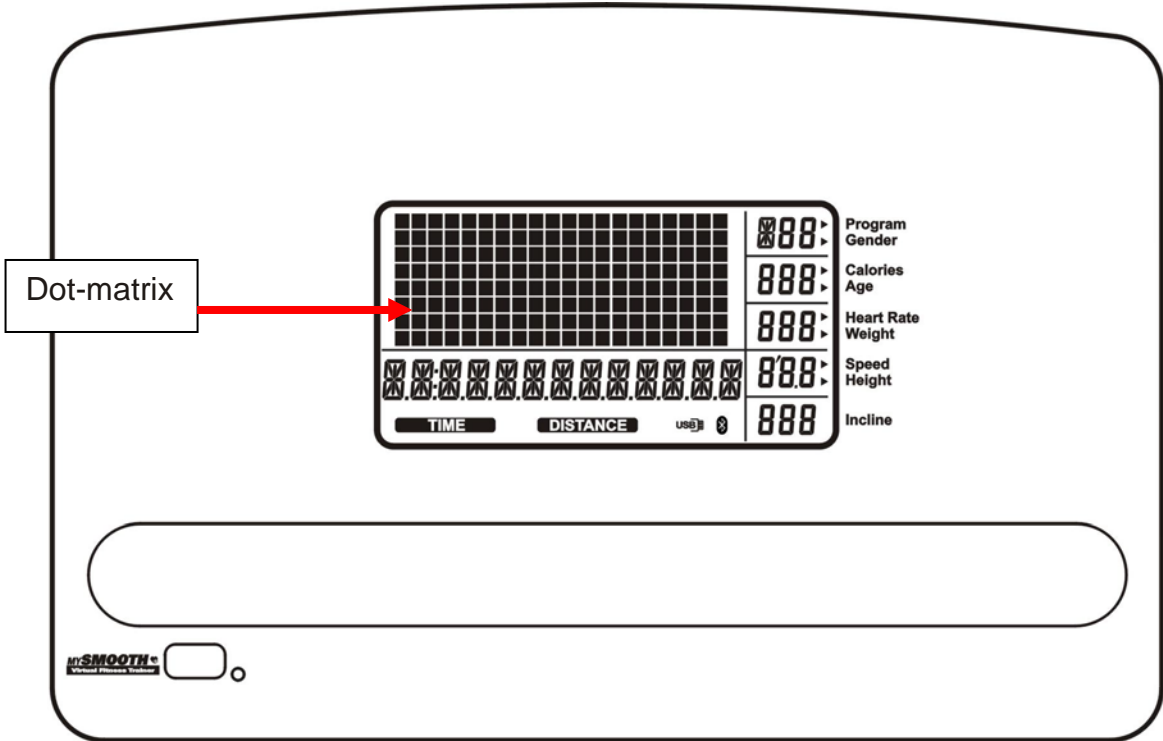

### Safety Key Pad

If the safety key is not present the treadmill will not function

**COMPUTER OPERATION****Display Function:**

<b>Program</b>	Displays program selection.
<b>Gender</b>	Displays set gender. M= Male, F=Female
<b>Calories</b>	Displays calories burned.
<b>Age</b>	Displays set age value.
<b>Heart Rate</b>	Displays hand grip and wireless Heart Rate reading.
<b>Weight</b>	Displays set weight value.
<b>Speed</b>	Displays the running speed.
<b>Height</b>	Displays set height value.
<b>Incline</b>	Displays current incline level 1-15.
<b>Time</b>	Displays time remaining or total time.
<b>Distance</b>	Displays total distance KM/Mi.
<b>USB</b>	Displays USB use.
<b>Dot-matrix</b>	Displays program profile.

**Buttons Functions:**

<b>Incline ▲ / ▼</b>	Adjusts the incline while in use. Adjusts program types and program values.
<b>Speed ▲ / ▼</b>	Adjusts the speed while in use. Adjusts program types and program values.
<b>Quick keys for Incline</b>	Adjusts incline to a predetermined value. There are 4 incline quick keys.
<b>Quick keys for Speed</b>	Adjusts speed to a predetermined value. There are 4 speed quick keys.
<b>Enter</b>	Confirm value entered.
<b>Quick Start / Pause</b>	Quick start or program start. Press to pause when in use.
<b>Stop / Reset</b>	To stop the treadmill while exercising. Will reset to User Select mode automatic). To reset back to the User Profile mode press twice and the computer will reset.
<b>Program select</b>	Selects program.
<b>Fan</b>	To switch on / off the fan.

## COMPUTER OPERATION

### SET UP USER PROFILE MODE:

At first, the LCD will show U1, and will also display only factory default setting values for user Gender, Weight, Height, and Age. Press the Speed  $- / +$  to choose the user number from 1 to 4 and press the Enter button to assign the user number shown. (If you insert the USB for My Smooth, the system will read the user's profile from USB and show them on the display)

Select from 1 of 4 user profiles. The user profile can be modified by following the following steps.

Before starting to exercise, press the speed adjust keys  $- / +$  to select the user First press and hold **【Program Select】**, then while holding the program button press and hold **【ENTER】**. The display will read set weight, choose the Gender by pressing the speed adjust

keys  $- / +$  then press **【ENTER】**. The display will read set age, choose the height by pressing the speed adjust keys  $- / +$  then press **【ENTER】**. The display will read set weight, choose the age by pressing the speed adjust keys  $- / +$  then press **【ENTER】**. The display will read set height, choose the gender by pressing the speed adjust keys  $- / +$  then press **【ENTER】**. You are now ready to select your program.

To skip the user profile mode, press enter (do not hold) and you will go directly to the program mode.



To record your exercise and health metrics, you must log on to [www.mysmoothtrainer.com](http://www.mysmoothtrainer.com). Then sync your MY Smooth Virtual Fitness Trainer USB device. Once complete simply plug in the MY Smooth Virtual Fitness Trainer USB device to your compatible Smooth Fitness exercise machine. Displayed on the equipment will be, your name, weight height and age. Press "START" button to begin your workout, the console will record your exercise data automatically, every 20 seconds, to your MY Smooth Virtual Fitness Trainer USB device. After your exercise session is complete, Insert the MY Smooth device in to the USB port of your PC or MAC to upload your data to The MY Smooth Virtual Fitness Trainer online health management program. The detailed reports show your exercise and health results, trends and recommendations to better achieve and maintain your fitness goals.

### QUICK START:

Press **Quick Start** to start the belt, the display will countdown 3 seconds with the LCD showing "3-2-1" then the belt will start moving.

1. Speed starts from 0.5ml, press **Speed**  $- / +$  to exercise speed by 0.1ml.
2. Incline level starts from Level 0, press **Incline**  $\blacktriangle / \blacktriangledown$  to change incline level.

### COOL DOWN PROGRAM:

1. When the programs reach 0 the treadmill will enter the cool down program, and then the speed will gradually lower the speed.
  - (1) Speed will lower 30%, after that the speed will lower 30% every 30 seconds until the speed lower to 2mph.
  - (2). Cool down program execute 5 minutes, program will be end when time reaches 0.
2. You can press and speed or incline key to change the speed or incline.

### P1 TARGET:

1. Press **【Program Select】** key to select **【TARGET】** then press enter to enter the program.
2. Set target time: press the **Speed**  $- / +$  to set the target time then press **【Enter】** to confirm.
3. Set target distance: press the **Speed**  $- / +$  to set the target distance then press **【Enter】** to confirm.
4. Set target calories: press the **Speed**  $- / +$  to set the target calories then press **【Start】** to begin.
5. Beginning the workout:

If either, Time, Distance and Calories are set the program will count down. Once the preset value reaches 0 the program will end. If no goal is set the program will not end unless manually stopped.

## COMPUTER OPERATION

## P2 Program:

1. Press **【Program Select】** key to select **【PROGRAM】** then press enter to enter the program. There are 15 preset programs.
2. Press the **Speed - / +** to change the program **【SPEED WEIGHT LOSS】**、**【SPEED ROLLING HILLS】**、**【SPEED TRAINING INTERVAL】**、**【SPEED SUMMIT】**、**【ENDURANCE TRAINING SPEED INTERVAL】**、**【INCLINE WEIGHT LOSS】**、**【INCLINE ROLLING HILLS】**、**【INCLINE TRAINING INTERVAL】**、**【ENDURANCE TRAINING INCLINE INTERVAL】**、**【MOUNTAIN SUBMMIT】**、**【VALLEY RUN】**、**【CROSS TRAINING】**、**【COMBINATION INTERVAL TRAINING】**、**【CROSS COUNTRY】**、**【MOUNTAIN JOG】** then press **【Enter】** to select program.
3. Set time: press the **Speed - / +** to set time then press **【Enter】** to confirm.
4. Set level: press the **Speed - / +** to set level then press **【Qucik Start】** to begin the workout..
5. Beginning the workout :
  - 5.1. The speed or incline will change automatically according to the program settings, the speed or incline will change every 2 minutes per segment if the time is in count up mode, if time is entered during setup then the segment time=set time / 20. You can use any speed or incline key to change speed or incline during your workout.
  - 5.2. The program will end when the counter reaches 0. Then enter cool down.

## 6. Preset program profiles:

## SPEED WEIGHT LOSS : Each Level speed value (incline=0)

Seg.	1	2	3	4	5	6	7	8	9	10	11	12	13	14	15	16	17	18	19	20
L1	1.5	2.0	2.5	3.0	3.5	3.5	3.5	3.5	3.5	3.5	3.5	3.5	3.5	3.5	3.5	3.5	3.0	2.5	2.0	1.5
L2	2.0	2.5	3.0	3.5	4.0	4.0	4.0	4.0	4.0	4.0	4.0	4.0	4.0	4.0	4.0	4.0	3.5	3.0	2.5	2.0
L3	2.5	3.0	3.5	4.0	4.5	4.5	4.5	4.5	4.5	4.5	4.5	4.5	4.5	4.5	4.5	4.5	4.0	3.5	3.0	2.5
L4	3.0	3.5	4.0	4.5	5.0	5.0	5.0	5.0	5.0	5.0	5.0	5.0	5.0	5.0	5.0	5.0	4.5	4.0	3.5	3.0
L5	3.5	4.0	4.5	5.0	5.5	5.5	5.5	5.5	5.5	5.5	5.5	5.5	5.5	5.5	5.5	5.5	5.0	4.5	4.0	3.5
L6	4.0	4.5	5.0	5.5	6.0	6.0	6.0	6.0	6.0	6.0	6.0	6.0	6.0	6.0	6.0	6.0	5.5	5.0	4.5	4.0
L7	4.5	5.0	5.5	6.0	6.5	6.5	6.5	6.5	6.5	6.5	6.5	6.5	6.5	6.5	6.5	6.5	6.0	5.5	5.0	4.5
L8	5.0	5.5	6.0	6.5	7.0	7.0	7.0	7.0	7.0	7.0	7.0	7.0	7.0	7.0	7.0	7.0	6.5	6.0	5.5	5.0
L9	5.5	6.0	6.5	7.0	7.5	7.5	7.5	7.5	7.5	7.5	7.5	7.5	7.5	7.5	7.5	7.5	7.0	6.5	6.0	5.5
L10	6.0	6.5	7.0	7.5	8.0	8.0	8.0	8.0	8.0	8.0	8.0	8.0	8.0	8.0	8.0	8.0	7.5	7.0	6.5	6.0

## SPEED ROLLING HILLS : Each Level speed value (incline=0)

Seg.	1	2	3	4	5	6	7	8	9	10	11	12	13	14	15	16	17	18	19	20
L1	1.5	2.0	2.5	3.0	2.5	2.0	1.5	2.0	2.5	3.0	2.5	2.0	1.5	2.0	2.5	3.0	2.5	2.0	1.5	1.5
L2	2.0	2.5	3.0	3.5	3.0	2.5	2.0	2.5	3.0	3.5	3.0	2.5	2.0	2.5	3.0	3.5	3.0	2.5	2.0	2.0
L3	2.5	3.0	3.5	4.0	3.5	3.0	2.5	3.0	3.5	4.0	3.5	3.0	2.5	3.0	3.5	4.0	3.5	3.0	2.5	2.5
L4	3.0	3.5	4.0	4.5	4.0	3.5	3.0	3.5	4.0	4.5	4.0	3.5	3.0	3.5	4.0	4.5	4.0	3.5	3.0	3.0
L5	3.5	4.0	4.5	5.0	4.5	4.0	3.5	4.0	4.5	5.0	4.5	4.0	3.5	4.0	4.5	5.0	4.5	4.0	3.5	3.5
L6	4.0	4.5	5.0	5.5	5.0	4.5	4.0	4.5	5.0	5.5	5.0	4.5	4.0	4.5	5.0	5.5	5.0	4.5	4.0	4.0
L7	4.5	5.0	5.5	6.0	5.5	5.0	4.5	5.0	5.5	6.0	5.5	5.0	4.5	5.0	5.5	6.0	5.5	5.0	4.5	4.5
L8	5.0	5.5	6.0	6.5	6.0	5.5	5.0	5.5	6.0	6.5	6.0	5.5	5.0	5.5	6.0	6.5	6.0	5.5	5.0	5.0
L9	5.5	6.0	6.5	7.0	6.5	6.0	5.5	6.0	6.5	7.0	6.5	6.0	5.5	6.0	6.5	7.0	6.5	6.0	5.5	5.5
L10	6.0	6.5	7.0	7.5	7.0	6.5	6.0	6.5	7.0	7.5	7.0	6.5	6.0	6.5	7.0	7.5	7.0	6.5	6.0	6.0







**COMPUTER OPERATION**

ENDURANCE TRAINING INCLINE INTERVAL : Each Level incline value (speed=0.6mph)

Seg.	1	2	3	4	5	6	7	8	9	10	11	12	13	14	15	16	17	18	19	20
L1	1	1	4	4	1	4	4	1	4	4	1	4	4	1	4	4	1	4	4	1
L2	2	2	5	5	2	5	5	2	5	5	2	5	5	2	5	5	2	5	5	2
L3	3	3	6	6	3	6	6	3	6	6	3	6	6	3	6	6	3	6	6	3
L4	4	4	7	7	4	7	7	4	7	7	4	7	7	4	7	7	4	7	7	4
L5	5	5	8	8	5	8	8	5	8	8	5	8	8	5	8	8	5	8	8	5
L6	6	6	9	9	6	9	9	6	9	9	6	9	9	6	9	9	6	9	9	6
L7	7	7	10	10	7	10	10	7	10	10	7	10	10	7	10	10	7	10	10	7
L8	8	8	11	11	8	11	11	8	11	11	8	11	11	8	11	11	8	11	11	8
L9	9	9	12	12	9	12	12	9	12	12	9	12	12	9	12	12	9	12	12	9
L10	10	10	13	13	10	13	13	10	13	13	10	13	13	10	13	13	10	13	13	10

MOUNTAIN SUMMIT : Each Level incline value (speed=0.6mph)

Seg.	1	2	3	4	5	6	7	8	9	10	11	12	13	14	15	16	17	18	19	20
L1	0	0	1	1	2	2	3	3	4	4	5	5	4	4	3	3	2	2	1	1
L2	1	1	2	2	3	3	4	4	5	5	6	6	5	5	4	4	3	3	2	2
L3	2	2	3	3	4	4	5	5	6	6	7	7	6	6	5	5	4	4	3	3
L4	3	3	4	4	5	5	6	6	7	7	8	8	7	7	6	6	5	5	4	4
L5	4	4	5	5	6	6	7	7	8	8	9	9	8	8	7	7	6	6	5	5
L6	5	5	6	6	7	7	8	8	9	9	10	10	9	9	8	8	7	7	6	6
L7	6	6	7	7	8	8	9	9	10	10	11	11	10	10	9	9	8	8	7	7
L8	7	7	8	8	9	9	10	10	11	11	12	12	11	11	10	10	9	9	8	8
L9	8	8	9	9	10	10	11	11	12	12	13	13	12	12	11	11	10	10	9	9
L10	9	9	10	10	11	11	12	12	13	13	14	14	13	13	12	12	11	11	10	10

VALLEY RUN : Each Level speed &amp; incline value

Seg.	1	2	3	4	5	6	7	8	9	10	11	12	13	14	15	16	17	18	19	20
L1	1.5	2.0	2.0	2.5	2.5	3.0	3.0	3.5	3.5	4.0	4.0	3.5	3.5	3.0	3.0	2.5	2.5	2.0	2.0	1.5
	4	4	4	3	3	2	2	1	1	0	0	1	1	2	2	3	3	4	4	4
L2	2.0	2.5	2.5	3.0	3.0	3.5	3.5	4.0	4.0	4.5	4.5	4.0	4.0	3.5	3.5	3.0	3.0	2.5	2.5	2.0
	5	5	5	4	4	3	3	2	2	1	1	2	2	3	3	4	4	5	5	5
L3	2.5	3.0	3.0	3.5	3.5	4.0	4.0	4.5	4.5	5.0	5.0	4.5	4.5	4.0	4.0	3.5	3.5	3.0	3.0	2.5
	6	6	6	5	5	4	4	3	3	2	2	3	3	4	4	5	5	6	6	6
L4	3.0	3.5	3.5	4.0	4.0	4.5	4.5	5.0	5.0	5.5	5.5	5.0	5.0	4.5	4.5	4.0	4.0	3.5	3.5	3.0
	7	7	7	6	6	5	5	4	4	3	3	4	4	5	5	6	6	7	7	7
L5	3.5	4.0	4.0	4.5	4.5	5.0	5.0	5.5	5.5	6.0	6.0	5.5	5.5	5.0	5.0	4.5	4.5	4.0	4.0	3.5
	8	8	8	7	7	6	6	5	5	4	4	5	5	6	6	7	7	8	8	8
L6	4.0	4.5	4.5	5.0	5.0	5.5	5.5	6.0	6.0	6.5	6.5	6.0	6.0	5.5	5.5	5.0	5.0	4.5	4.5	4.0
	9	9	9	8	8	7	7	6	6	5	5	6	6	7	7	8	8	9	9	9
L7	4.5	5.0	5.0	5.5	5.5	6.0	6.0	6.5	6.5	7.0	7.0	6.5	6.5	6.0	6.0	5.5	5.5	5.0	5.0	4.5
	10	10	10	9	9	8	8	7	7	6	6	7	7	8	8	9	9	10	10	10
L8	5.0	5.5	5.5	6.0	6.0	6.5	6.5	7.0	7.0	7.5	7.5	7.0	7.0	6.5	6.5	6.0	6.0	5.5	5.5	5.0
	11	11	11	10	10	9	9	8	8	7	7	8	8	9	9	10	10	11	11	11
L9	5.5	6.0	6.0	6.5	6.5	7.0	7.0	7.5	7.5	8.0	8.0	7.5	7.5	7.0	7.0	6.5	6.5	6.0	6.0	5.5
	12	12	12	11	11	10	10	9	9	8	8	9	9	10	10	11	11	12	12	12
L10	6.0	6.5	6.5	7.0	7.0	7.5	7.5	8.0	8.0	8.5	8.5	8.0	8.0	7.5	7.5	7.0	7.0	6.5	6.5	6.0
	13	13	13	12	12	11	11	10	10	9	9	10	10	11	11	12	12	13	13	13



**COMPUTER OPERATION**

CROSS COUNTRY : Each Level speed &amp; incline value

Seg.	1	2	3	4	5	6	7	8	9	10	11	12	13	14	15	16	17	18	19	20
L1	1.5	2.0	3.5	3.0	4.0	2.5	3.0	3.0	4.0	2.0	2.0	4.0	3.0	3.5	2.0	2.5	4.0	3.0	2.5	1.5
	0	4	2	3	1	5	3	1	0	5	5	0	3	2	5	4	2	1	0	0
L2	2.0	2.5	4.0	3.5	4.5	3.0	3.5	3.5	4.5	2.5	2.5	4.5	3.5	4.0	2.5	3.0	4.5	3.5	3.0	2.0
	1	5	3	4	2	6	4	2	1	6	6	1	4	3	6	5	3	2	1	1
L3	2.5	3.0	4.5	4.0	5.0	3.5	4.0	4.0	5.0	3.0	3.0	5.0	4.0	4.5	3.0	3.5	5.0	4.0	3.5	2.5
	2	6	4	5	3	7	5	3	2	7	7	2	5	4	7	6	4	3	2	2
L4	3.0	3.5	5.0	4.5	5.5	4.0	4.5	4.5	5.5	3.5	3.5	5.5	4.5	5.0	3.5	4.0	5.5	4.5	4.0	3.0
	3	7	5	6	4	8	6	4	3	8	8	3	6	5	8	7	5	4	3	3
L5	3.5	4.0	5.5	5.0	6.0	4.5	5.0	5.0	6.0	4.0	4.0	6.0	5.0	5.5	4.0	4.5	6.0	5.0	4.5	3.5
	4	8	6	7	5	9	7	5	4	9	9	4	7	6	9	8	6	5	4	4
L6	4.0	4.5	6.0	5.5	6.5	5.0	5.5	5.5	6.5	4.5	4.5	6.5	5.5	6.0	4.5	5.0	6.5	5.5	5.0	4.0
	5	9	7	8	6	10	8	6	5	10	10	5	8	7	10	9	7	6	5	5
L7	4.5	5.0	6.5	6.0	7.0	5.5	6.0	6.0	7.0	5.0	5.0	7.0	6.0	6.5	5.0	5.5	7.0	6.0	5.5	4.5
	6	10	8	9	7	11	9	7	6	11	11	6	9	8	11	10	8	7	6	6
L8	5.0	5.5	7.0	6.5	7.5	6.0	6.5	6.5	7.5	6.0	5.5	7.5	6.5	7.0	5.5	6.0	7.5	6.5	6.0	5.0
	7	11	9	10	8	12	10	8	7	12	12	7	10	9	12	11	9	8	7	7
L9	5.5	6.0	7.5	7.0	8.0	6.5	7.0	7.0	8.0	6.5	6.0	8.0	7.0	7.5	6.0	6.5	8.0	7.0	6.5	5.5
	8	12	10	11	9	13	11	9	8	13	13	8	11	10	13	12	10	9	8	8
L10	6.0	6.5	8.0	7.5	8.5	7.0	7.5	7.5	8.5	7.0	6.5	8.5	7.5	8.0	6.5	7.0	8.5	7.5	7.0	6.0
	9	13	11	12	10	14	12	10	9	14	14	9	12	11	14	13	11	10	9	9

MOUNTAIN JOG : Each Level speed &amp; incline value

Seg.	1	2	3	4	5	6	7	8	9	10	11	12	13	14	15	16	17	18	19	20
L1	1.5	3.0	3.0	4.0	3.5	3.0	2.5	2.0	1.5	2.0	2.5	3.0	3.5	3.5	4.0	3.0	2.5	2.5	2.0	1.5
	0	2	2	0	1	2	3	5	5	4	4	3	3	2	2	1	1	1	0	0
L2	2.0	3.5	3.5	4.5	3.5	3.5	3.0	2.5	2.0	2.5	3.0	3.5	4.0	4.0	4.5	3.5	3.0	3.0	2.5	2.0
	1	3	3	1	2	3	4	6	6	5	5	4	4	3	3	2	2	2	1	1
L3	2.5	4.0	4.0	5.0	4.0	4.0	3.5	3.0	2.5	3.0	3.5	4.0	4.5	4.5	5.0	4.0	3.5	3.5	3.0	2.5
	2	4	4	2	3	4	5	7	7	6	6	5	5	4	4	3	3	3	2	2
L4	3.0	4.5	4.5	5.5	4.5	4.5	4.0	3.5	3.0	3.5	4.0	4.5	5.0	5.0	5.5	4.5	4.0	4.0	3.5	3.0
	3	5	5	3	4	5	6	8	8	7	7	6	6	5	5	4	4	4	3	3
L5	3.5	5.0	5.0	6.0	5.0	5.0	4.5	4.0	3.5	4.0	4.5	5.0	5.5	5.5	6.0	5.0	4.5	4.5	4.0	3.5
	4	6	6	4	5	6	7	9	9	8	8	7	7	6	6	5	5	5	4	4
L6	4.0	5.5	5.5	6.5	5.5	5.5	5.0	4.5	4.0	4.5	5.0	5.5	6.0	6.0	6.5	5.5	5.0	5.0	4.5	4.0
	5	7	7	5	6	7	8	10	10	9	9	8	8	7	7	6	6	6	5	5
L7	4.5	6.0	6.0	7.0	6.0	6.0	5.5	5.0	4.5	5.0	5.5	6.0	6.5	6.5	7.0	6.0	5.5	5.5	5.0	4.5
	6	8	8	6	7	8	9	11	11	10	10	9	9	8	8	7	7	7	6	6
L8	5.0	6.5	6.5	7.5	6.5	6.5	6.0	6.0	5.0	5.5	6.0	6.5	7.0	7.0	7.5	6.5	6.0	6.0	5.5	5.0
	7	9	9	7	8	9	10	12	12	11	11	10	10	9	9	8	8	8	7	7
L9	5.5	7.0	7.0	8.0	7.0	7.0	6.5	6.5	5.5	6.0	6.5	7.0	7.5	7.5	8.0	7.0	6.5	6.5	6.0	5.5
	8	10	10	8	9	10	11	13	13	12	12	11	11	10	10	9	9	9	8	8
L10	6.0	7.5	7.5	8.5	7.5	7.5	7.0	7.0	6.0	6.5	7.0	7.5	8.0	8.0	8.5	7.5	7.0	7.0	6.5	6.0
	9	11	11	9	10	11	12	14	14	13	13	12	12	11	11	10	10	10	9	9

## COMPUTER OPERATION

### P3 HRC(Heart Rate Control):

1. Press **【Program Select】** to select the **【HRC】** program and press enter.
2. There are 4 types of HRC program. TARGET H.R., FAT BURN, CARDIO, PERFORMANCE, press **Speed - / +** to select the desired HRC program then press **【Enter】** to confirm.
3. Set time: Press the **Speed - / +** to set the time then press **【Enter】** to confirm.
4. Set target heart rate: TARGET H.R. mode preset value=130 (MHR mode preset value depends on the age set) press the **Speed - / +** to set the target heart then press **【Enter】** to confirm.
5. Set begin speed: Speed window shows lowest begin speed, press **Speed - / +** to set begin speed then press **【Start】** to begin workout.
6. Beginning the workout:
  - 6.1. The program will compare the real time and preset target heart rate every 30 seconds to adjust incline until the actual heart rate is reaches with in + or - 5 beats of the preset target heart rate.
    - (1). During the program, if the actual pulse rate  $\leq$  target workout heart rate minus 5, the incline will be increased one level every 30 seconds until the max. level.
    - (2). During the program, if the actual pulse rate  $\geq$  target workout heart rate plus 5, the incline will be decreased one level every 30 seconds until the min. level.
  - 6.2. You can use any speed or incline key or device to change the speed or incline during your workout.
  - 6.3. The program will end when the counter reaches 0, then enter cool down.

### P4 Fitness test

1. Press **【Program Select】** to select the **【Fitness test】** program and press enter.
2. Set begin speed : Speed window shows lowest speed, press the speed - / + to set begin speed then press **【START】** to begin workout.
3. Beginning the workout :
  - 3.1. This program is testing your fitness condition, how far you can run in 12 minutes, you can use any speed key to change the speed during your workout, the incline function is not available.
  - 3.2. The program will end when the counter reaches 0.
  - 3.3. Test result : **【VERY GOOD】** , **【GOOD】** , **【AVERAGE】** , **【BAD】** , **【VERY BAD】**

### P5 CUSTOM:

1. Press **【Program Select】** to select the **【CUSTOM】** program and press enter.
2. There are 4 customs for the user to build their own program, press speed - / + to select custom 1 ~ custom 4 then press **【ENTER】** to confirm.
3. Set each Segment : There 20 Segments you can set according to your desired levels of intensity, you can set the speed, incline and time in each segment.
  - 3.1. Set speed : Press the speed - / + to set the speed of the segment.
  - 3.2. Set incline : Press the incline **▲ / ▼** to set the incline of the segment.
  - 3.3. Set time : After setting the speed and incline press **【ENTER】** to set time, press speed - / + to set time then press **【ENTER】** to confirm and move to the next segment.
4. Press **【START】** to begin workout after all segments are set, the custom program will now be saved for future use.
5. Beginning the workout:
  - 5.1. The speed and incline change automatically according to the values previously set. The program will move from one segment to the next after the preset time for each segment expires. The program will skip any segments that are set to 0 time.
  - 5.2. The program will end when the last segment time reaches 0.

## MUSIC JACK USAGE

**NOTE:**

High speaker volume may interfere with the heart rate accuracy. Please decrease the speaker volume when you are using the heart rate function.

※ Warning: After removing the safety key, wait for 5 seconds to re-insert in.

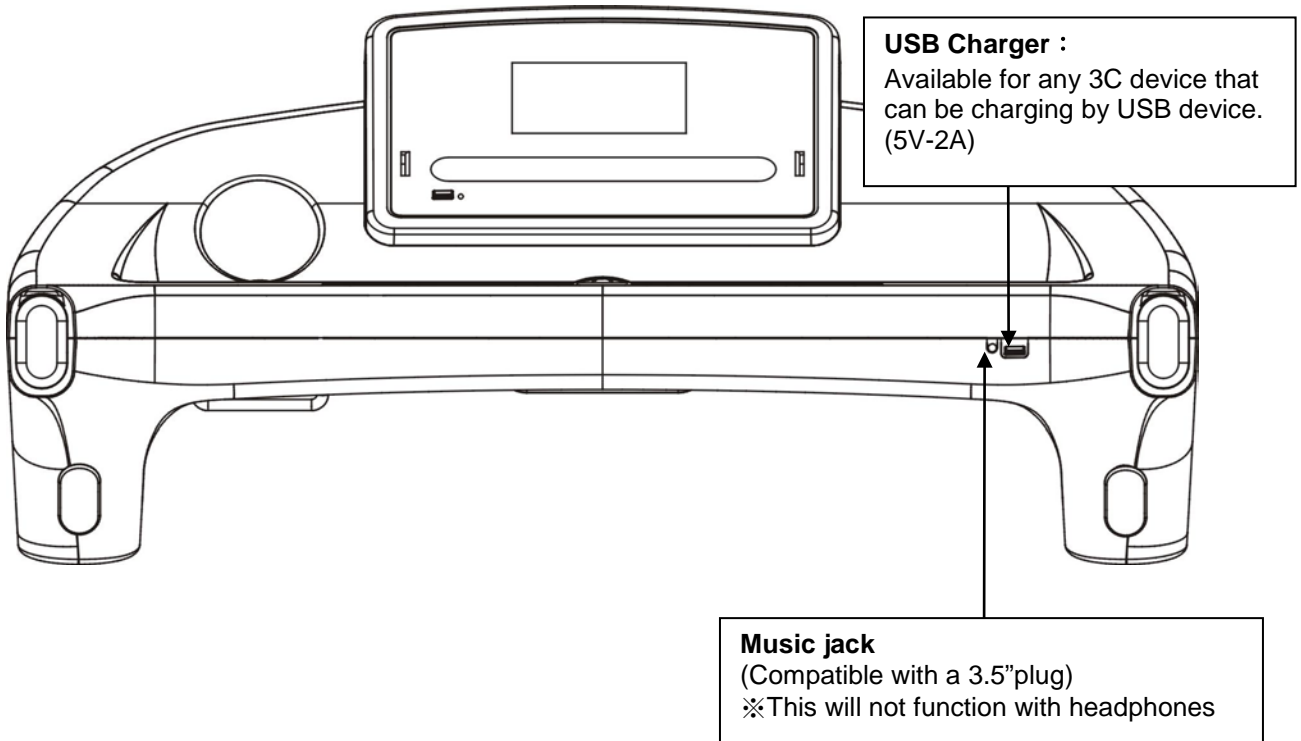

## TROUBLESHOOTING

SYMPTOM	CAUSE	SOLUTION
No power to display	A). Not plugged in. B). Power switch not activated C). Power input circuit breaker blown.	Please check power input and fuse. Contact your dealer if unit is plugged in, powered on and circuit breaker is depressed.
LCD display abnormal	LCD damaged	Contact your dealer for troubleshooting
SPEED ERROR	A).speed feed back problem. B).Motor console damaged.	Switch off the power and switch on after 10 seconds then press START. Check: 1. Does the running belt move? 2. If the running belt moves, does error message appear after 10 seconds? If the belt moves and message does not appear after powering off, lubricate the running belt and deck. If the belt moved and message appears, please contact your dealer.
Show E7	Incline motor malfunction.	You can keep going to use except adjust the grade. Contact your agent to determine and get solutions.



**LIMITED WARRANTY****LIMITED HOME USE WARRANTY – SMOOTH FITNESS Treadmill Warranty**

**Warranty Coverage:** EVO Fitness and Smooth Fitness, Inc. ("Smooth Fitness") warrants to the original owner that each new product to be free from defects in workmanship and material, under normal use and conditions.

**Period of Coverage:** The Warranty on this product runs from the date of original purchase using the following schedule:

Model Name	Frame	Drive Motor & Deck	Parts & Electronics	Labor
735i USA only	Lifetime	Lifetime	7 years	2 years
735i Canada	Lifetime	Lifetime	7 years	1 year

Labor: Smooth Fitness will reimburse for labor costs for Two (2) years\*. Smooth Fitness reserves the right to either: Hire and reimburse an independent service technician who will come into the home for the repair,  
OR

In the event that there is not an available certified Smooth Fitness service technician, Smooth will send the part directly to the consumer and will pay \$75 US per occurrence for the labor costs of such repair. If multiple repair attempts must be made for one reported problem, Smooth will only reimburse once per occurrence.

Smooth Fitness reserves the right to inspect damaged parts for misuse. Your Original Receipt is proof of purchase and should be kept with the product manual. You may be required to show proof of purchase prior to warranty service being initiated.

**Remedy Provided by Smooth Fitness:** Smooth Fitness will provide a replacement part free of charge if a defect is found during the Warranty period. Smooth Fitness may at its discretion, choose to provide any of following parts or repair options. In the event that a part is determined in need of replacement, upon receipt of the part by Smooth Fitness, Smooth Fitness may send out the part by UPS ground or another such carrier directly to the customer's home.

Any redemption may be by repair or replacement of the affected parts and/or product at the sole discretion of Smooth Fitness, by personnel approved by Smooth Fitness.

Parts repaired or replaced pursuant to this Warranty shall be warranted for the unexpired portion of the Warranty applying to the original product. Any technical advice furnished before or after delivery in regard to the use or application of Smooth Fitness products is furnished without charge and on the basis that it represents Smooth Fitness' best judgment under the circumstances but that the advice is used at your sole risk.

**Procedure for Obtaining Your Remedy Under This Warranty:** To obtain service on a Smooth Fitness product, call Smooth Fitness. In the instance that service is not available in an area, Smooth Fitness, at its discretion, can either 1) find a service technician in your area to perform warranty service, 2) have a local dealer perform warranty service, or 3) send the warranty parts to you and reimburse as described above. To help the technician assist you, please have the following information ready:

- Model name or number from the cover of the manual;
- Serial number located on the frame of the unit; and
- The part description and the order number.

**Limitations on Warranty:** This Warranty does not cover any problems, damages or failures that are caused by accident, improper assembly, failure to observe cautionary labels on the product, failure to operate the product correctly, power grid failures or spikes from your local electricity provider, abuse or freight damage. Smooth Fitness does not warrant against any damage or defects that may result from repair or alterations made to the product by an unauthorized repair facility. In order for this warranty to be valid, all Smooth Fitness and EVO Fitness exercise equipment must be stored and used in a fully finished and livable room within the residence (not including an indoor swimming pool room).

This Warranty shall terminate if you sell or otherwise transfer this product. This Warranty does not apply to any product shipped or handled outside of the United States or Canada. This Warranty does not apply if the product is used as a rental product or in commercial use. Consequential and incidental damages are not recoverable under this Warranty. (Some states do not allow the exclusion or limitation of incidental or consequential damages, so the above limitation or exclusion may not apply to you.)

THIS WARRANTY IS EXPRESSLY IN LIEU OF ALL OTHER EXPRESS WARRANTIES. ALL IMPLIED WARRANTIES, INCLUDING WARRANTIES OF MERCHANTABILITY OR FITNESS FOR ANY PARTICULAR PURPOSE, ARE LIMITED IN DURATION TO TWO (2) YEARS\* FROM THE EFFECTIVE DATE OF THIS WARRANTY. SMOOTH FITNESS IS NOT LIABLE FOR CONSEQUENTIAL OR INCIDENTAL DAMAGES RESULTING FROM ANY DEFECT IN PARTS NOR FOR ANY BREACH OF EXPRESS OR IMPLIED WARRANTIES. SMOOTH FITNESS' SOLE LIABILITY UNDER THIS WARRANTY IS LIMITED TO THE TERMS DESCRIBED IN THIS FORM. THIS WARRANTY GIVES YOU SPECIFIC LEGAL RIGHTS, AND YOU MAY ALSO HAVE OTHER RIGHTS WHICH VARY FROM STATE TO STATE.

\*Two year labor is valid only with the continental United States; Canadian labor warranties are valid for the period of 1 year from date of purchase.  
FORM WS-1 (rev. 03/2008)



Smooth Fitness  
780 5<sup>th</sup> Ave  
King of Prussia, PA 19406

Toll Free Customer Service:  
**1.888.800.1167**

Website:  
**[www.smoothfitness.com](http://www.smoothfitness.com)**