

DEALER SET-UP INSTRUCTIONS & CHECKLIST for SNAPPER 26" HIGH WHEEL MOWERS

This SNAPPER High Wheel Mower is equipped with a Blade Brake Clutch (BBC). This allows the machine to be started and operated with the blade disengaged (OFF). Releasing the blade control on this machine STOPS only the blade. The engine continues to run. The engine is stopped by moving the engine speed control to STOP position. These mowers are designed for quick set-up. The checklist should be filled out by the dealer as the items are checked off and/or performed and the Consumer/Operator Product Registration card filled out and sent to the Customer Service department at SNAPPER when completed. CAUTION: Cutting blades are extremely sharp. Wear heavy leather gloves when handling or working with blades. Be careful to avoid cutting yourself on sharp edges of blade.

- STEP 1:** Remove High Wheel mower from crate.
- STEP 2:** Rotate handle brackets until they line up with holes in rear case. Install bolts (5/16"X 1" carriage) from inside and use 5/16"-18 Nylok nuts to secure. DO NOT tighten at this time.
- STEP 3:** Assemble handles onto handle brackets using hardware provided in kit. Tighten to 12 to 22 ft. lbs.
- NOTE:** Make sure control cables are routed on the inside of handles and are not pinched.
- STEP 4:** Install speed control rod into speed control sector. See Figure 1.

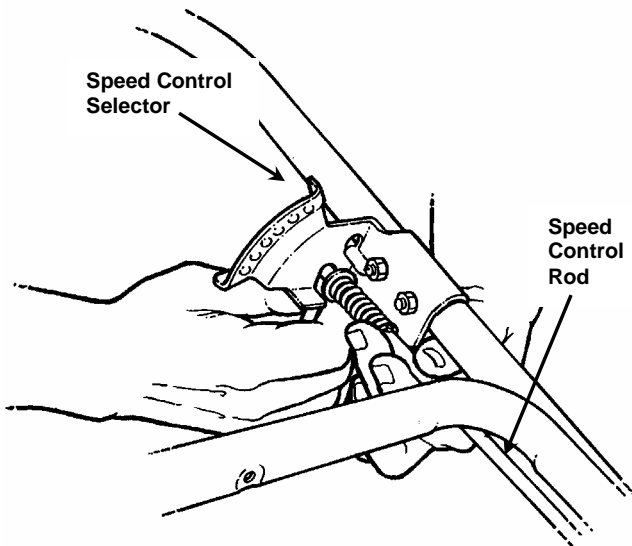

FIGURE 1

- STEP 5:** Attach speed control rod to control rod at rear of mower. Tighten securely using wing nut provided in kit. See Figure 2.
- STEP 6:** Adjust handle to desired height and securely tighten handle bracket fasteners.
- STEP 7:** Remove spindle cover and check adjustment of deck belt. To check this adjustment, measure the length of the idler tension spring when the blade control is in the "OFF" position.

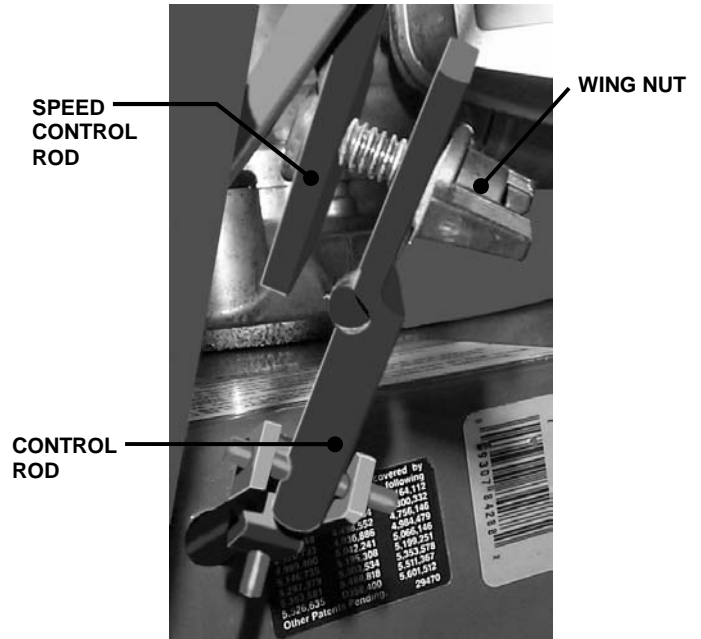

FIGURE 2

WARNING

Engine must be OFF for this adjustment.

STEP 8: Move blade control to the "ON" position and measure the length of the spring. The spring should be extended 1/4"-3/8" from it's original position. If adjustment is needed, adjust the thumb wheel on the upper left handle until proper spring extension is achieved. Install cover. See Figure 3.

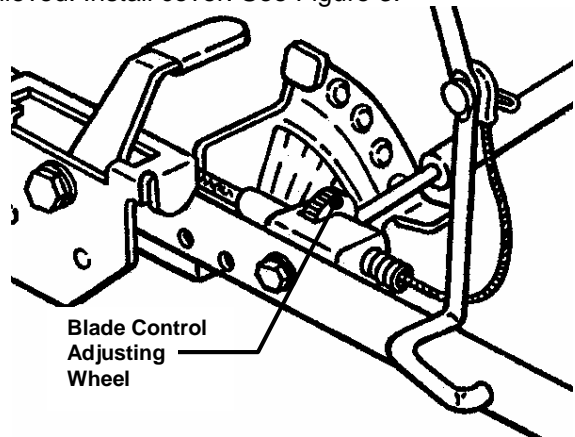

FIGURE 3

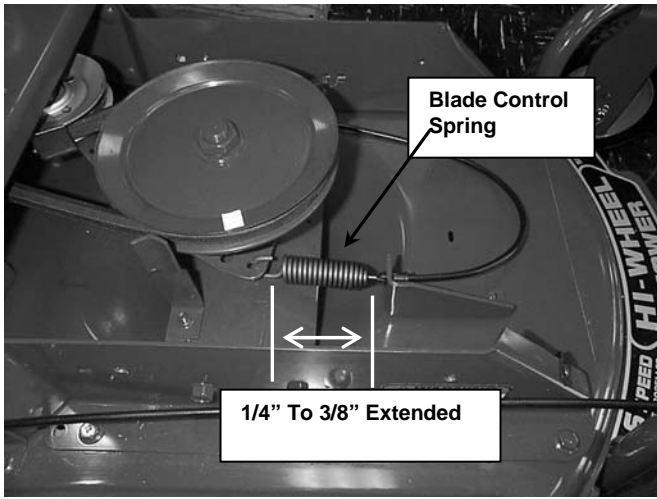

FIGURE 3

STEP 9: Check adjustment of wheel drive control spring. With the wheel drive control lever in the "OFF/Released" position measure the length of the wheel drive control spring. Move the wheel drive control lever to the "ON" position and measure spring length. The spring should extend 1/2" to 3/4" from its original length.

⚠ WARNING ⚠
Engine must be OFF for this adjustment.

If adjustment is needed, unhook wheel drive control spring from cable and rotate spring until proper spring extension is achieved. See Figure 4. Set cutting height as desired.

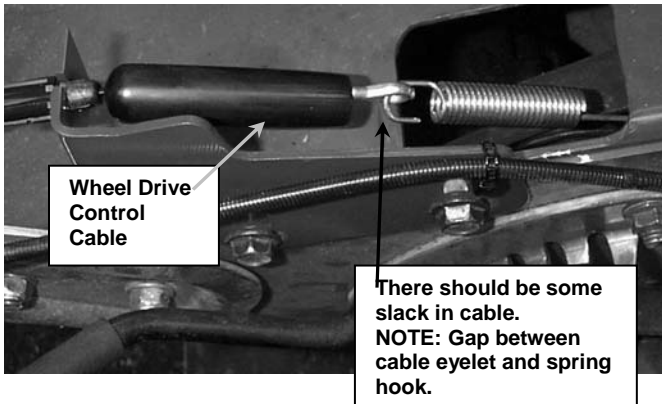

FIGURE 4

STEP 10: Fill engine to full mark on dipstick. See Engine Manual for proper oil specifications.

STEP 11: Set-Up is now complete.

DEALER SET-UP & CHECKLIST for SNAPPER 26" HIGH WHEEL MOWERS

The following must be achieved upon the purchase of the mower. It is very important that the Dealer performs and accomplishes the set-up and the operational tests as listed below.

SET-UP (Details on Pages 1 & 2 of this Instruction)

- _____ FOAM SHIPPING BLOCK removed from cutting blade.
- _____ UPPER HANDLE & LOWER HANDLE secured in place and hardware tightened securely.
- _____ SIDE CHUTE installed on mower.
- _____ BLADE retaining bolt(s) checked and tighten securely.

LUBRICATION

- _____ ENGINE OIL added to bring level up to full mark on 4-cycle engines (Refer to Engine Manual).
- _____ OIL mixed with FUEL in specified ratio (2 Cycle Engines Only).
- _____ DIFFERENTIAL grease checked and added if needed.

OPERATIONAL TEST

- _____ ENGINE started, engine control settings checked and adjusted as needed.
- _____ WHEEL DRIVE checked for proper operation and adjusted as needed
- _____ DRIVE DISC adjustment checked and made
- _____ GROUND SPEED control checked

CPSC (Consumer Product Safety Commission) COMPLIANCE TEST

- _____ BLADE CONTROL stops blade rotation when released.

DEALER'S RECORDS & FINAL CHECK

- _____ PERSONALLY HANDED Operator's Manual & Mower Safety Booklet to purchaser.
- _____ INSTRUCTED purchaser to read and follow instructions in Operator's Manual.
- _____ DEMONSTRATED proper starting procedure and operation of mower to purchaser.
- _____ INSTRUCTED purchaser how to service air cleaner, maintain oil level (4-cycle).
- _____ ASSISTED purchaser in completing Product Registration Card.

CONSUMER/OPERATOR PRODUCT REGISTRATION CARD

Purchase Date _____ Model _____ Serial No. _____

Retailers Name _____ Signature _____

Address _____ City _____ State _____ Zip _____

MOWER WILL BE USED COMMERCIALY? _____ YES _____ NO

Purchaser's Name _____ Signature _____

Address _____ City _____ State _____ Zip _____

IMPORTANT: This form is to be retained by the Dealer for future reference regarding Warranty, proof of purchase, traceability for product recall or service, etc. Complete the Product Registration Card and Mail to Customer Service Department at SNAPPER, P.O. BOX 1379, McDonough, Georgia, 30253.