



OPERATOR'S MANUAL



Coronet / 2400 / RE 200 Series

13HP Hydro Riders

Mfg. No.	Description
1694610	Coronet, 13HP
1694612	Coronet, 13HP (CE)
1694613	2413H, 13HP
1694614	2413H, 13HP (CE)
1694615	RE1330, 13HP
1694616	RE1330, 13HP (CE)
1695508	Coronet, 13HP
1695509	RE1330, 13HP
2690244	Coronet, 13HP & 30" Mower
2690246	Coronet, 13HP & 30" Mower (CE)
2690247	2413H, 13HP & 30" Mower
2690248	2413H, 13HP & 30" Mower (CE)
2690249	RE1330, 13HP & 30" Mower
2690250	RE1330, 13HP & 30" Mower (CE)
2690800	Coronet, 13HP & 30" Mower
2690801	RE1330, 13HP & 30" Mower

16HP Hydro Riders

Mfg. No.	Description
1694611	Coronet, 16HP
1695510	Coronet, 16HP
2690245	Coronet, 16HP & 34" Mower
2690802	Coronet, 16HP & 34" Mower

30" Mower Decks

Mfg. No.	Description
1692543	30" Mower Deck
1694053	30" Mower Deck
1694511	30" Mower Deck (CE)
1694537	30" Mower Deck

34" Mower Decks

Mfg. No.	Description
1692545	34" Mower Deck
1694191	34" Mower Deck

1726959

Revision E

Rev. Date 10/2008

TP10004528

**THIS PAGE INTENTIONALLY BLANK
(FOR PLACEMENT ONLY - DO NOT PRINT)**



Table of Contents

Safety Rules & Information	4	Troubleshooting, Adjustments & Service	25
Identification Numbers	9	Troubleshooting the Rider.....	25
Safety Decals	10	Troubleshooting the Mower	26
Features & Controls	12	Seat Adjustment.....	27
Control Functions	12	Steering Gear Adjustment.....	27
Safety Interlock System	14	Steering Wheel Adjustment	27
Operating the Rider	14	Brake Adjustment.....	28
General	14	Blade Brake Adjustment	28
Adding Fuel.....	14	Mower Adjustments	29
Checks Before Starting	14	Battery Charging	31
Brake Pedal Operation.....	15	Rider Drive Belt Replacement.....	32
Starting The Engine	15	Mower Belt Replacement.....	32
Selecting Ground & Engine Speed	16	Specifications	33
Stopping the Rider	16	Parts & Accessories	34
Operating the Mower	16		
Mowing in Reverse	17		
Attachment Operation in Reverse	17		
Pushing the Rider by Hand	17		
Mower Removal and Installation.....	18		
Storage	19		
Regular Maintenance	20		
Maintenance Schedule	20		
Checking Tire Pressures.....	20		
Raising the Seat Deck	21		
Adding Fuel.....	21		
Fuel Filter	21		
Oil & Filter Change.....	21		
Check / Change Air Filter.....	21		
Replace Spark Plug	21		
Lubrication	22		
Battery Maintenance	23		
Cleaning the Battery and Cables	23		
Lubricate Rear Axle Shafts	23		
Servicing the Mower Blades	24		

NOTE: In this manual, "left" and "right" are referred to as seen from the operating position.



Operating Safety

Congratulations on purchasing a superior-quality piece of lawn and garden equipment. Our products are designed and manufactured to meet or exceed all industry standards for safety.

Power equipment is only as safe as the operator. If it is misused, or not properly maintained, it can be dangerous! Remember, you are responsible for your safety and that of those around you.

Use common sense, and think through what you are doing. If you are not sure that the task you are about to perform can be safely done with the equipment you have chosen, ask a professional: contact your local authorized dealer.

Read the Manual

The operator's manual contains important safety information you need to be aware of **BEFORE** you operate your unit as well as **DURING** operation.

Safe operating techniques, an explanation of the product's features and controls, and maintenance information is included to help you get the most out of your equipment investment.

Be sure to completely read the Safety Rules and Information found on the following pages. Also completely read the Operation section.

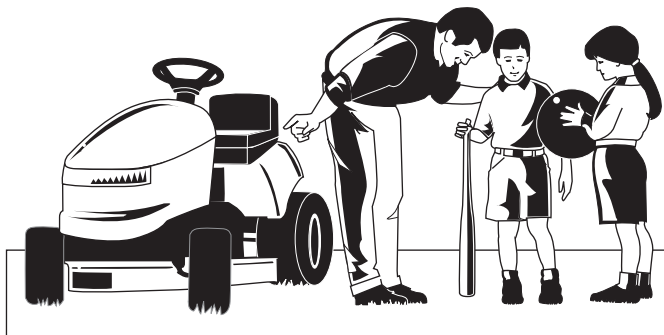

Children

Tragic accidents can occur with children. Do not allow them anywhere near the area of operation. Children are often attracted to the unit and mowing activity. Never assume that children will remain where you last saw them. If there is a risk that children may enter the area where you are mowing, have another responsible adult watch them.

DO NOT GIVE CHILDREN RIDES ON THIS UNIT! This encourages them to come near the unit in the future while it is running, and they could be seriously hurt. They may then approach the unit for a ride when you are not expecting it, and you may run over them.

Reverse

Do not mow in reverse unless absolutely necessary. Always look down and behind before and while traveling in reverse even with the mower blades disengaged.



Slope Operation

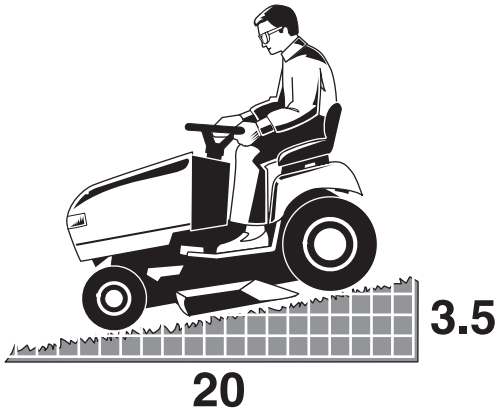

You could be seriously injured or even killed if you use this unit on too steep an incline. Using the unit on a slope that is too steep or where you don't have adequate traction can cause you to lose control or roll over.

A good rule of thumb is to not operate on any slope you cannot back up (in 2-wheel drive mode). You should not operate on inclines with a slope greater than a 3.5 foot rise over a 20 foot length. Always drive up and down slopes: never cross the face.

Also note that the surface you are driving on can greatly impact stability and control. Wet grass or icy pavement can seriously affect your ability to control the unit.

If you feel unsure about operating the unit on an incline, don't do it. It's not worth the risk.

Moving Parts

This equipment has many moving parts that can injure you or someone else. However, if you are seated in the seat properly, and follow all the rules in this book, the unit is safe to operate.

The mower deck has spinning mower blades that can amputate hands and feet. Do not allow anyone near the equipment while it is running!

To help you, the operator, use this equipment safely, it is equipped with an operator-present safety system. Do NOT attempt to alter or bypass the system. See your dealer immediately if the system does not pass all the safety interlock system tests found in this manual.

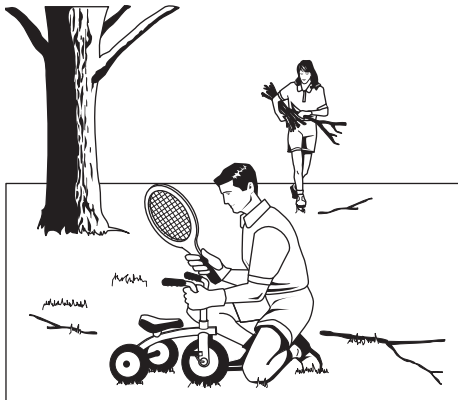
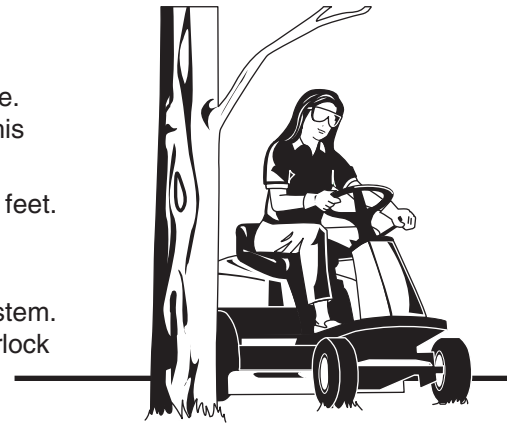

Thrown Objects

This unit has spinning mower blades. These blades can pick up and throw debris that could seriously injure a bystander. Be sure to clean up the area to be mowed BEFORE you start mowing.

Do not operate this unit without the entire grass catcher or discharge guard (deflector) in place.

Also, do not allow anyone in the area while the unit is running! If someone does enter the area, shut the unit off immediately until they leave.

Fuel and Maintenance

Gasoline is extremely flammable. Its vapors are also extremely flammable and can travel to distant ignition sources. Gasoline must only be used as a fuel, not as a solvent or cleaner. It should never be stored any place where its vapors can build up or travel to an ignition source like a pilot light. Fuel belongs in an approved, plastic, sealed gas can, or in the tractor fuel tank with the cap securely closed. Spilled fuel needs to be cleaned up immediately.

Proper maintenance is critical to the safety and performance of your unit. Be sure to perform the maintenance procedures listed in this manual, especially periodically testing the safety system.



Safety Rules & Information



Read these safety rules and follow them closely. Failure to obey these rules could result in loss of control of unit, severe personal injury or death to you, or bystanders, or damage to property or equipment.

This mowing deck is capable of amputating hands and feet and throwing objects.

The triangle  in text signifies important cautions or warnings which must be followed.

GENERAL OPERATION

1. Read, understand, and follow all instructions in the manual and on the unit before starting.
2. Do not put hands or feet near rotating parts or under the machine. Keep clear of the discharge opening at all times.
3. Only allow responsible adults, who are familiar with the instructions, to operate the unit (local regulations can restrict operator age).
4. Clear the area of objects such as rocks, toys, wire, etc., which could be picked up and thrown by the blade(s).
5. Be sure the area is clear of other people before mowing. Stop the unit if anyone enters the area.
6. Never carry passengers.
7. Do not mow in reverse unless absolutely necessary. Always look down and behind before and while traveling in reverse.
8. Never direct discharge material toward anyone. Avoid discharging material against a wall or obstruction. Material may ricochet back toward the operator. Stop the blade(s) when crossing gravel surfaces.
9. Do not operate the machine without the entire grass catcher, discharge guard (deflector), or other safety devices in place.
10. Slow down before turning.
11. Never leave a running unit unattended. Always disengage the PTO, set parking brake, stop engine, and remove keys before dismounting.
12. Disengage blades (PTO) when not mowing. Shut off engine and wait for all parts to come to a complete stop before cleaning the machine, removing the grass catcher, or unclogging the discharge guard.
13. Operate the machine only in daylight or good artificial light.
14. Do not operate the unit while under the influence of alcohol or drugs.
15. Watch for traffic when operating near or crossing roadways.
16. Use extra care when loading or unloading the unit into a trailer or truck.
17. Always wear eye protection when operating this unit.
18. Data indicates that operators, age 60 years and above, are involved in a large percentage of power equipment-related injuries. These operators should evaluate their ability to operate the equipment safely enough to protect themselves and others from injury.
19. Follow the manufacturer's recommendations for wheel weights or counterweights.
20. Keep in mind the operator is responsible for accidents occurring to other people or property.
21. All drivers should seek and obtain professional and practical instruction.
22. Always wear substantial footwear and trousers. Never operate when barefoot or wearing sandals.
23. Before using, always visually check that the blades and blade hardware are present, intact, and secure. Replace worn or damaged parts.
24. Disengage attachments before: refueling, removing an attachment, making adjustments (unless the adjustment can be made from the operator's position).
25. When the machine is parked, stored, or left unattended, lower the cutting means unless a positive mechanical lock is used.
26. Before leaving the operator's position for any reason, engage the parking brake (if equipped), disengage the PTO, stop the engine, and remove the key.
27. To reduce fire hazard, keep the unit free of grass, leaves, & excess oil. Do not stop or park over dry leaves, grass, or combustible materials.
28. It is a violation of California Public Resource Code Section 4442 to use or operate the engine on or near any forest-covered, brush-covered, or grass-covered land unless the exhaust system is equipped with a spark arrester meeting any applicable local or state laws. Other states or federal areas may have similar laws.

TRANSPORTING AND STORAGE

1. When transporting the unit on an open trailer, make sure it is facing forward, in the direction of travel. If the unit is facing backwards, wind lift could damage the unit.
2. Always observe safe refueling and fuel handling practices when refueling the unit after transportation or storage.
3. Never store the unit (with fuel) in an enclosed poorly ventilated structure. Fuel vapors can travel to an ignition source (such as a furnace, water heater, etc.) and cause an explosion. Fuel vapor is also toxic to humans and animals.
4. Always follow the engine manual instructions for storage preparations before storing the unit for both short and long term periods.
5. Always follow the engine manual instructions for proper start-up procedures when returning the unit to service.
6. Never store the unit or fuel container inside where there is an open flame or pilot light, such as in a water heater. Allow unit to cool before storing.

SLOPE OPERATION

Slopes are a major factor related to loss-of-control and tip-over accidents, which can result in severe injury or death. Operation on all slopes requires extra caution. If you cannot back up the slope or if you feel uneasy on it, do not operate on it.

Control of a walk-behind or ride-on machine sliding on a slope will not be regained by the application of the brake. The main reasons for loss of control are: insufficient tire grip on the ground, speed too fast, inadequate braking, the type of machine is unsuitable for its task, lack of awareness of the ground conditions, incorrect hitching and load distribution.

1. Mow up and down slopes, not across.
2. Watch for holes, ruts, or bumps. Uneven terrain could overturn the unit. Tall grass can hide obstacles.
3. Choose a slow speed so that you will not have to stop or change speeds while on the slope.
4. Do not mow on wet grass. Tires may lose traction.
5. Always keep unit in gear especially when traveling down slopes. Do not shift to neutral and coast downhill.
6. Avoid starting, stopping, or turning on a slope. If tires lose traction, disengage the blade(s) and proceed slowly straight down the slope.
7. Keep all movement on slopes slow and gradual. Do not make sudden changes in speed or direction, which could cause the machine to rollover.
8. Use extra care while operating machines with grass catchers or other attachments; they can affect the stability of the unit. Do not use on steep slopes.
9. Do not try to stabilize the machine by putting your foot on the ground (ride-on units).
10. Do not mow near drop-offs, ditches, or embankments. The mower could suddenly turn over if a wheel is over the edge of a cliff or ditch, or if an edge caves in.
11. Do not use grass catchers on steep slopes.
12. Do not mow slopes you cannot back up them.
13. See your authorized dealer/retailer for recommendations of wheel weights or counterweights to improve stability.
14. Remove obstacles such as rocks, tree limbs, etc.
15. Use slow speed. Tires may lose traction on slopes even through the brakes are functioning properly.
16. Do not turn on slopes unless necessary, and then, turn slowly and gradually downhill, if possible.

TOWED EQUIPMENT (RIDE-ON UNITS)

1. Tow only with a machine that has a hitch designed for towing. Do not attach towed equipment except at the hitch point.
2. Follow the manufacturer's recommendations for weight limit for towed equipment and towing on slopes.
3. Never allow children or others in or on towed equipment.
4. On slopes, the weight of the towed equipment may cause loss of traction and loss of control.
5. Travel slowly and allow extra distance to stop.
6. Do not shift to neutral and coast downhill.

WARNING

Never operate on slopes greater than 17.6 percent (10°) which is a rise of 3-1/2 feet (106 cm) vertically in 20 feet (607 cm) horizontally.

When operating on slopes use additional wheel weights or counterweights. See your dealer/retailer to determine which weights are available and appropriate for your unit.

Select slow ground speed before driving onto slope. In addition to front weights, use extra caution when operating on slopes with rear-mounted grass catchers.

Mow UP and DOWN the slope, never across the face, use caution when changing directions and **DO NOT START OR STOP ON SLOPE.**

CHILDREN

Tragic accidents can occur if the operator is not alert to the presence of children. Children are often attracted to the unit and the mowing activity. Never assume that children will remain where you last saw them.

1. Keep children out of the mowing area and under the watchful care of another responsible adult.
2. Be alert and turn unit off if children enter the area.
3. Before and during reverse operation, look behind and down for small children.
4. Never carry children, even with the blade(s) off. They may fall off and be seriously injured or interfere with safe unit operation. Children who have been given rides in the past may suddenly appear in the mowing area for another ride and be run over or backed over by the machine.
5. Never allow children to operate the unit.
6. Use extra care when approaching blind corners, shrubs, trees, or other objects that may obscure vision.

EMISSIONS

1. Engine exhaust from this product contains chemicals known, in certain quantities, to cause cancer, birth defects, or other reproductive harm.
2. Look for the relevant Emissions Durability Period and Air Index information on the engine emissions label.

IGNITION SYSTEM

1. This spark ignition system complies with Canadian standard ICES-002.

Safety Rules & Information

SERVICE AND MAINTENANCE

Safe Handling of Gasoline

1. Extinguish all cigarettes, cigars, pipes, and other sources of ignition.
2. Use only approved gasoline containers.
3. Never remove the gas cap or add fuel with the engine running. Allow the engine to cool before refueling.
4. Never fuel the machine indoors.
5. Never store the machine or fuel container where there is an open flame, spark, or pilot light such as near a water heater or other appliance.
6. Never fill containers inside a vehicle or on a truck bed with a plastic bed liner. Always place containers on the ground away from your vehicle before filling.
7. Remove gas-powered equipment from the truck or trailer and refuel it on the ground. If this is not possible, then refuel such equipment on a trailer with a portable container, rather than from a gasoline dispenser nozzle.
8. Keep nozzle in contact with the rim of the fuel tank or container opening at all times until fueling is complete. Do not use a nozzle lock-open device.
9. If fuel is spilled on clothing, change clothing immediately.
10. Never over-fill the fuel tank. Replace gas cap and tighten securely.
11. Use extra care in handling gasoline and other fuels. They are flammable and vapors are explosive.
12. If fuel is spilled, do not attempt to start the engine but move the machine away from the area of spillage and avoid creating any source of ignition until fuel vapors have dissipated.
13. Replace all fuel tank caps and fuel container caps securely.

Service & Maintenance

1. Never run the unit in an enclosed area where carbon monoxide fumes may collect.
2. Keep nuts and bolts, especially blade attachment bolts, tight and keep equipment in good condition.
3. Never tamper with safety devices. Check their proper operation regularly and make necessary repairs if they are not functioning properly.
4. Keep unit free of grass, leaves, or other debris build-up. Clean up oil or fuel spillage, and remove any fuel-soaked debris. Allow machine to cool before storage.
5. If you strike an object, stop and inspect the machine. Repair, if necessary, before restarting.
6. Never make adjustments or repairs with the engine running.
7. Check grass catcher components and the discharge guard frequently and replace with manufacturer's recommended parts, when necessary.
8. Mower blades are sharp. Wrap the blade or wear gloves, and use extra caution when servicing them.
9. Check brake operation frequently. Adjust and service as required.
10. Maintain or replace safety and instructions labels, as necessary.
11. Do not remove the fuel filter when the engine is hot as spilled gasoline may ignite. Do not spread fuel line clamps further than necessary. Ensure clamps grip hoses firmly over the filter after installation.

12. Do not use gasoline containing METHANOL, gasohol containing more than 10% ETHANOL, gasoline additives, or white gas because engine/fuel system damage could result.
13. If the fuel tank must be drained, it should be drained outdoors.
14. Replace faulty silencers/mufflers.
15. Maintain or replace safety and instruction labels as necessary.
16. Use only factory authorized replacement parts when making repairs.
17. Always comply with factory specifications on all settings and adjustments.
18. Only authorized service locations should be utilized for major service and repair requirements.
19. Never attempt to make major repairs on this unit unless you have been properly trained. Improper service procedures can result in hazardous operation, equipment damage and voiding of manufacturer's warranty.
20. On multiple blade mowers, take care as rotating one blade can cause other blades to rotate.
21. Do not change engine governor settings or over-speed the engine. Operating the engine at excessive speed can increase the hazard of personal injury.
22. Disengage drive attachments, stop the engine, remove the key, and disconnect the spark plug wire(s) before: clearing attachment blockages and chutes, performing service work, striking an object, or if the unit vibrates abnormally. After striking an object, inspect the machine for damage and make repairs before restarting and operating the equipment.
23. Never place hands near the moving parts, such as a hydro pump cooling fan, when the tractor is running. (Hydro pump cooling fans are typically located on top of the transaxle).
24. Units with hydraulic pumps, hoses, or motors: **WARNING:** Hydraulic fluid escaping under pressure may have sufficient force to penetrate skin and cause serious injury. If foreign fluid is injected into the skin it must be surgically removed within a few hours by a doctor familiar with this form of injury or gangrene may result. Keep body and hands away from pin holes or nozzles that eject hydraulic fluid under high pressure. Use paper or cardboard, and not hands, to search for leaks. Make sure all hydraulic fluid connections are tight and all hydraulic hoses and lines are in good condition before applying pressure to the system. If leaks occur, have the unit serviced immediately by your authorized dealer.
25. **WARNING:** Stored energy device. Improper release of springs can result in serious personal injury. Springs should be removed by an authorized technician.
26. Models equipped with an engine radiator: **WARNING:** Stored energy device. To prevent serious bodily injury from hot coolant or steam blow-out, never attempt to remove the radiator cap while the engine is running. Stop the engine and wait until it is cool. Even then, use extreme care when removing the cap.

Identification Numbers



North American / CE Models



Tractor ID Tag

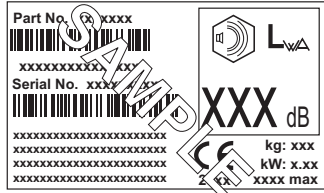

CE Models (Only)

When contacting your authorized dealer for replacement parts, service, or information you **MUST** have these numbers.

Record your model name/number, manufacturer's identification numbers, and engine serial numbers in the space provided for easy access. These numbers can be found in the locations shown.

NOTE: For location of engine identification numbers, refer to the engine owner's manual.

PRODUCT REFERENCE DATA	
Model Description Name/Number	
Unit MFG Number	Unit SERIAL Number
Mower Deck MFG Number	Mower Deck SERIAL Number
Dealer Name	Date Purchased
ENGINE REFERENCE DATA	
Engine Make	Engine Model
Engine Type/Spec	Engine Code/Serial Number

CE IDENTIFICATION TAG MARKINGS

- A. Manufacturer's Identification Number
- B. Manufacturer's Serial Number
- C. Power Rating in Kilowatts
- D. Maximum Engine Speed in Rotations per Minute
- E. Manufacturer's Name and Address
- F. Year of Manufacture
- G. CE Compliance Logo
- H. Mass of Unit in Kilograms
- I. Guaranteed Sound Power in Decibels

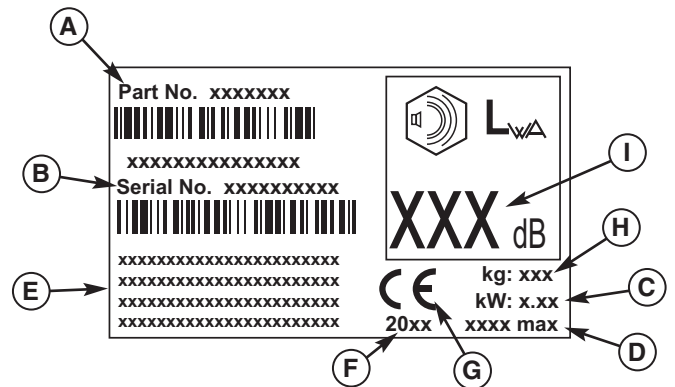

Safety Decals

SAFETY DECALS

This unit has been designed and manufactured to provide you with the safety and reliability you would expect from an industry leader in outdoor power equipment manufacturing.

Although reading this manual and the safety instructions it contains will provide you with the necessary basic knowledge to operate this equipment safely and effectively, we have placed several safety labels on the unit to remind you of this important information while you are operating your unit.

All DANGER, WARNING, CAUTION and instructional messages on your rider and mower should be carefully read and obeyed. Personal bodily injury can result when these instructions are not followed. The information is for your safety and it is important! The safety decals below are on your rider and mower.

If any of these decals are lost or damaged, replace them at once. See your local dealer for replacements.

These labels are easily applied and will act as a constant visual reminder to you, and others who may use the equipment, to follow the safety instructions necessary for safe, effective operation.

NORTH AMERICAN MODELS

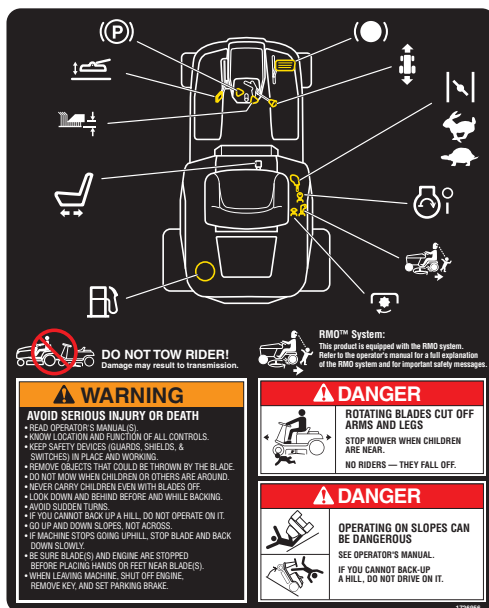

Decal - Operating Instructions, North American Models, Part No. 1726956

CE MODELS

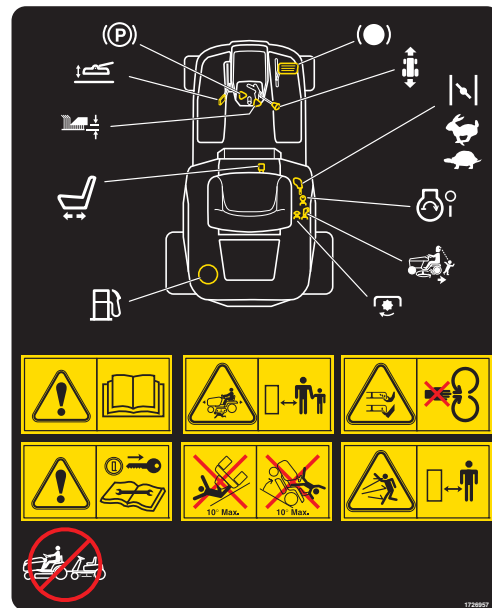

Decal - Operating Instructions, CE Models, Part No. 1726957



Decal - Danger, Side-Discharge Models Part No. 1704276



Decal - Danger, Side-Discharge Models Part No. 1704277



Decal - Danger, Rotating Blades Part No. 1720389

ALL MODELS

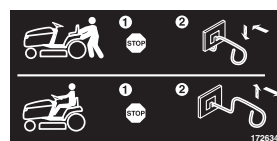

Decal - Transmission Release Part No. 1726341



Decal - Ignition Switch Positions Part No. 1722806

SAFETY ICONS

Warning: Read Operator's Manual.

Read and understand the Operator's Manual before using this machine.



Danger: Machine Rollover.

Do not use this machine on slopes greater than 10°.



Danger: Thrown Objects.

This machine is capable of throwing objects and debris. Keep bystanders away.



Danger: Dismemberment.

This machine can amputate limbs. Keep bystanders and children away when engine is running.

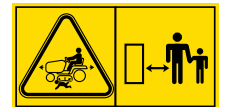

Warning: Remove Key Before Servicing.

Remove the key and consult technical literature before performing repairs or maintenance.



Danger: Dismemberment.

This mower deck can amputate limbs. Keep hands and feet away from blades.





Fuel Tank

To remove the cap, turn counterclockwise.



PTO Switch

The PTO (Power Take-Off) switch engages and disengages attachments that use the PTO. To engage the PTO, pull UP on the switch. Push DOWN to disengage. *Note that the operator must be seated firmly in the tractor seat for the PTO to function.*



Transmission Release Valve Lever

The transmission release valve lever deactivates the transmission so that the tractor can be pushed by hand. See “Pushing the Tractor by Hand” for operational information.



Ignition Switch

The ignition switch starts and stops the engine, it has three positions:



OFF Stops the engine and shuts off the electrical system.



RUN Allows the engine to run and powers the electrical system.



START Cranks the engine for starting.

NOTE: Never leave the ignition switch in the RUN position with the engine stopped—this drains the battery.



Brake Pedal

Depressing the brake pedal applies the tractor brake.



Ground Speed Lever

The tractor’s forward ground speed is controlled by the forward ground speed control lever. The tractor’s reverse ground speed is controlled by the reverse ground speed control pedal.

Moving the lever forward will increase ground speed. Note that the further forward the lever is moved, the faster the tractor will travel.



Parking Brake

The parking brake knob is used to lock the parking brake when the tractor is stopped. Fully depressing the brake pedal and pulling up on the knob engages the parking brake.



Mower Height of Cut Adjustment

The cutting height adjustment knob controls the mower cutting height. The cutting height is infinitely adjustable between 1” and 3-3/4.”



Seat Adjustment Lever

The seat can be adjusted forward and back. Move the lever, position the seat as desired, and release the lever to lock the seat into position.



Attachment Lift Control Lever

When using the mower deck, lift the deck off the ground while transporting to and from the job site. **DO NOT** cut with the mower in the raised, transport position.



Reverse Mowing Option (RMO)

The Reverse Mowing Option allows for mowing (or use of other PTO driven attachments) while traveling in reverse. If you choose to mow or operate another attachment in reverse, turn the RMO key after the PTO is engaged. The L.E.D. light will illuminate, and the operator can then mow in reverse. Each time the PTO is disengaged the RMO needs to be reactivated if desired.

Operating the Rider



SAFETY INTERLOCK SYSTEM

This unit is equipped with safety interlock switches and other safety devices. These safety systems are present for your safety, do not attempt to bypass safety switches, and never tamper with safety devices. Check their operation regularly.

Operational SAFETY Checks

Your unit is equipped with a seat switch safety system. Check the seat switch operation every fall and spring with the following tests.

Test 1 — Engine should NOT crank if any of the following conditions exist:

- Transmission lever is OUT of Neutral, OR
- PTO switch is engaged (ON), OR
- Clutch/brake pedal is NOT fully depressed.

Test 2 — Engine SHOULD crank if ALL of the following conditions are met:

- Transmission lever is IN neutral, AND
- PTO switch is NOT engaged, AND
- Clutch/brake pedal IS fully depressed.

Test 3 — Engine should SHUT OFF if any of the following conditions exist:

- Operator rises off seat with clutch/brake pedal NOT fully depressed (parking brake OFF), OR
- Operator rises off seat with PTO engaged.

NOTE: If operator returns to seat before engine stops, the engine will re-start and electric PTO clutch will re-engage.

NOTE: Once the engine has stopped, PTO switch must be turned off after operator returns to the seat in order to start the engine.

Test 4 — Blade Brake Check

Mower blades and mower drive belt should come to a complete stop within five seconds after electric PTO switch is turned off. If mower drive belt does not stop within five seconds, see your dealer.

Test 5 — Test 5 — Reverse Mow Option (RMO) Check

- Engine should shut off if reverse travel is attempted if the PTO has been switched on and RMO has not been activated.
- RMO light should illuminate when RMO has been activated.



WARNING

If the unit does not pass a safety test, do not operate it. See your authorized dealer. Under no circumstance should you attempt to defeat the purpose of the safety interlock system.

GENERAL OPERATING SAFETY

Be sure to read all information in the SAFETY RULES AND INFORMATION section before attempting to operate this unit. Become familiar with all of the controls and how to stop the unit.

ADDING FUEL

To add fuel:

1. Remove the fuel cap (A, Figure 4).
2. Fill the tank. Do not overfill. Leave room in the tank for fuel expansion. Refer to your engine manual for specific fuel recommendations.
3. Install and hand tighten the fuel cap.

CHECKS BEFORE STARTING

- Check that crankcase is filled to full mark on dipstick. See the Engine Manual for instructions and oil recommendations.
- Make sure all nuts, bolts, screws and pins are in place and tight.
- Adjust the seat position, and make certain you can reach all controls from operator's position.
- Fill the gasoline tank with fresh fuel. Refer to engine manual for fuel recommendations.
- Make certain proper wheel or counterweights are installed if required, and use extra caution if you will be operating the unit on sloping ground.

BRAKE PEDAL OPERATION

1. See Figure 2. Depressing the pedal from position A to B disengages the transmission drive and also returns the transmission control lever to neutral (from forward speeds). Fully depressing the pedal to position B applies the rider brake.
2. See Figure 2. Parking brake is applied at pedal position B when parking brake control knob (C) is pulled up with pedal fully depressed.

STARTING THE ENGINE

1. Seat yourself on the rider seat in the operating position. Set the parking brake using the brake pedal (D, Figure 3) and parking brake knob (B).
2. Disengage the PTO clutch.
3. Set the throttle to FULL.
4. Close the choke.

NOTE: A warm engine may not require choking.

5. Insert the ignition key and turn it to START.
6. After the engine starts, move the engine throttle control to SLOW. Warm up the engine by running it for at least a minute.
7. Set throttle to FULL.

NOTE: In the event of an emergency the engine can be stopped by simply turning the ignition switch to STOP. Use this method only in emergency situations. For normal engine shut down follow the procedure given in "Stopping the Rider."

WARNING

Make certain the area of operation, and especially the direction of travel is clear of objects, people and animals. Always look DOWN AND BEHIND before backing!

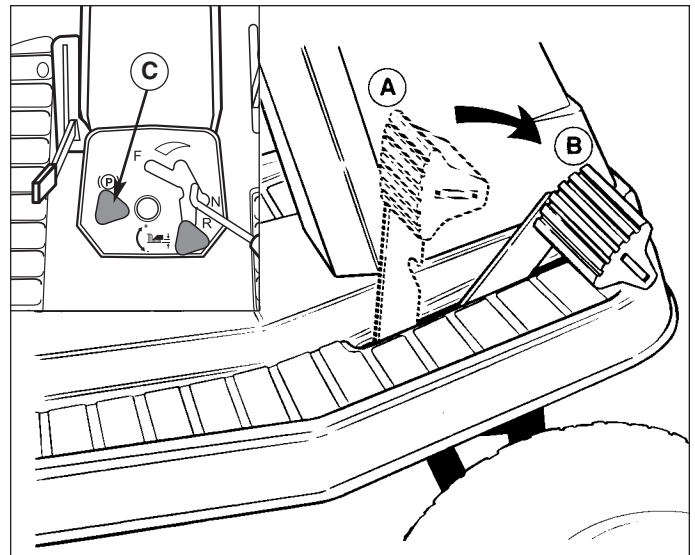
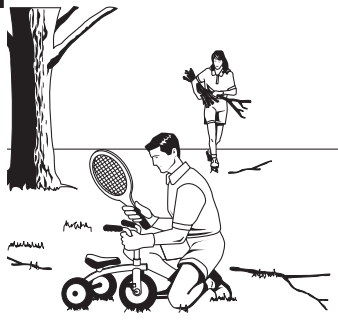

Figure 2. Brake Pedal
A. Brake Pedal (Disengaged)
B. Brake Pedal (Engaged)
C. Parking Brake Knob

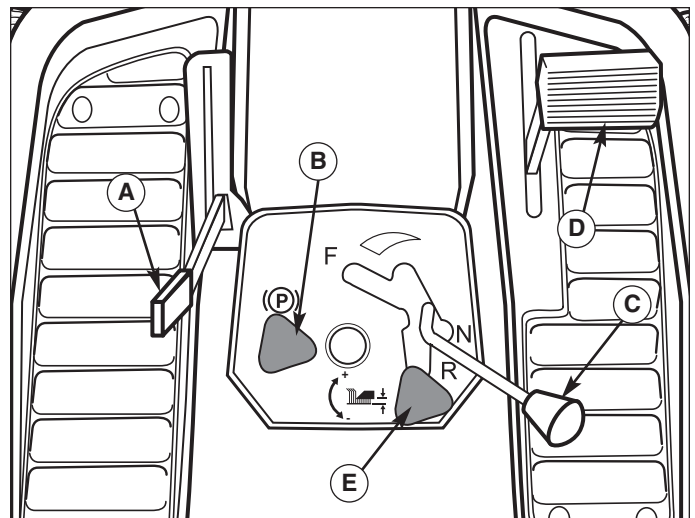

Figure 3. Controls
A. Mower Lift Lever
B. Parking Brake Knob
C. Ground Speed Control Lever
D. Clutch/Brake Pedal
E. Dial-A-Cut™ Control

Operating the Rider

SELECTING GROUND & ENGINE SPEED

Ground speed is selected by releasing the clutch/brake pedal (D, Figure 4) and moving the control lever (C, Figure 4) to the appropriate speed selection. If the terrain is rough, hilly or sloping, use first or second gear. If the grass is wet or over 3" (76 mm) high, use full engine speed (with slow ground speed) so the mower will have enough power to cut the grass.

1. If you are ready to mow, lower the mower from the transport position using lever (A, Figure 4) and set the mowing height using the Dial-A-Cut™ Control (E, Figure 4).
2. Set the engine throttle for full speed.
3. Use the PTO switch to engage the PTO.
4. Release the parking brake by depressing the clutch/brake pedal and pushing knob (B, Figure 4) down.
5. Move the ground speed control lever (C, Figure 4) to the desired direction and speed of travel to set the rider in motion.
6. Adjust engine throttle to the desired speed. Full throttle is recommended for mowing.

! WARNING

Make certain the area of operation, and especially the direction of travel is clear of objects, people and animals. Always look DOWN AND BEHIND before backing!



STOPPING THE RIDER

1. Move the ground speed control lever (C, Figure 4) into the NEUTRAL position to make a gradual stop. To make a more rapid stop, depress the clutch/brake pedal (D, Figure 4).

NOTE: The ground speed control lever will return to neutral from forward automatically when the clutch/brake pedal is depressed.

2. Engage the parking brake by fully depressing brake pedal and pulling up on parking brake knob (B, Figure 4).
3. Use the PTO switch (G, Figure 1) to disengage the PTO.
4. Set the engine throttle (M, Figure 1) to 1/2 throttle setting and allow the engine to idle for 20 seconds. Stopping a hot engine too fast may cause engine damage.
5. Turn key (C, Figure 1) to OFF and remove it.

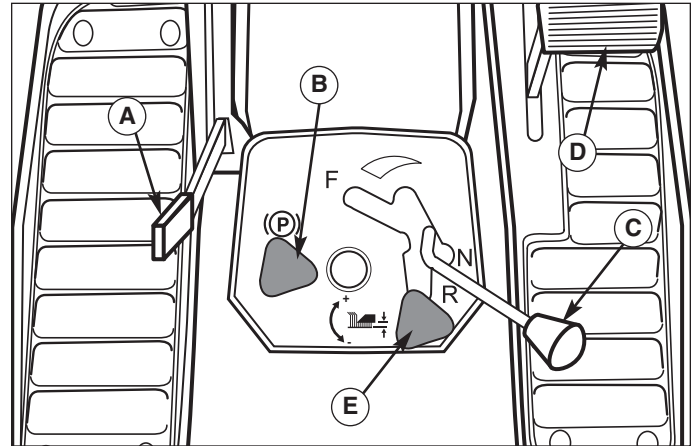

Figure 4. Controls

- A. Mower Lift Lever**
- B. Parking Brake Knob**
- C. Ground Speed Control Lever**
- D. Clutch/Brake Pedal**
- E. Dial-A-Cut™ Control**

! WARNING

Make certain direction of travel is clear of objects, people and animals.

Always look DOWN AND BEHIND before backing!



OPERATING THE MOWER

1. When traveling to or from the work site, fully raise the mower using the mower lift lever (A, Figure 4). At the work site, lower mower using the lift lever.
2. Use the Dial-A-Cut™ control (E, Figure 4) to adjust the height of the mower. Pull back slightly on mower lift lever (A, Figure 4) to relieve pressure and turn clockwise to raise mower cutting height, or counter-clockwise to lower cutting height.
3. Engage the parking brake. Make sure the PTO switch is disengaged.
4. Start the engine (see "Starting the Engine").
5. Fully lower the mower using the attachment lift lever.
6. Set the throttle to FULL.
7. Engage the PTO (Mower Deck).
8. Begin mowing.
9. When finished, shut off the PTO and raise the mower using the attachment lift control lever.
10. Stop the engine (see "Stopping the Rider").

NOTE: Cutting height scale is located on the quadrant at base of lift lever. Scale is numbered 1 thru 4, with 4 representing the highest cutting height.

⚠️ WARNING

The engine will shut off if the reverse ground speed pedal is depressed while the PTO is on and the RMO has not been activated. The operator should always turn the PTO off prior to driving across on roads, paths or any area that maybe used by other vehicles. Sudden loss of drive could create a hazard

⚠️ WARNING

Mowing in reverse can be hazardous to bystanders. Tragic accidents can occur if the operator is not alert to the presence of children. Never activate RMO if children are present. Children are often attracted to the unit and the mowing activity.

MOWING IN REVERSE

If an operator chooses to mow in reverse, the RMO system can be used. To use the Reverse Mowing Option (RMO) turn the RMO key after the PTO is engaged. The L.E.D. light will illuminate, and the operator can then mow in reverse. Each time the PTO is disengaged the RMO needs to be reactivated if desired. The key should be removed to restrict access to the RMO feature.

ATTACHMENT OPERATION IN REVERSE

If an operator chooses to operate a PTO driven attachment in reverse, the RMO system can be used. To use the Reverse Mowing Option (RMO) turn the RMO key after the PTO is engaged. The L.E.D. light will illuminate, and the operator can then operate the attachment in reverse. Each time the PTO is disengaged the RMO needs to be reactivated if desired. The key should be removed to restrict access to the RMO feature.

PUSHING THE RIDER BY HAND

1. Disengage the PTO and turn the engine off.
2. Push the transmission release (A, Figure 6) in and push down to lock into released position.
3. The tractor can now be pushed by hand.



DO NOT TOW TRACTOR

Towing the unit will cause transmission damage. • Do not use another vehicle to push or pull this unit. • Do not actuate the transmission release valve lever while the engine is running.

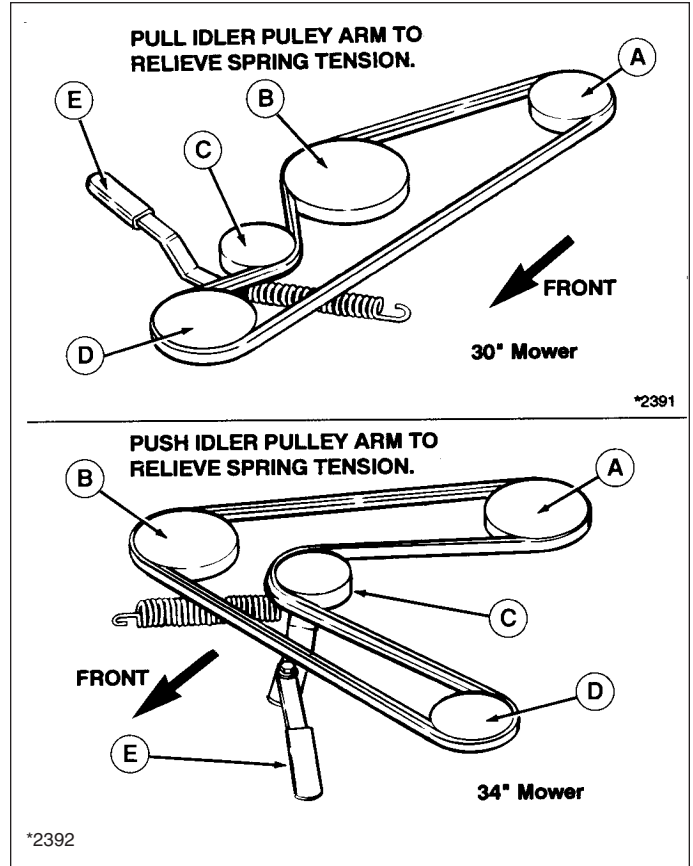

Figure 5. Mower Belt Pattern

- | | |
|---|--|
| A. PTO Pulley | D. Front Idler Pulley (30")
Left Arbor Pulley (34") |
| B. Arbor Pulley (30")
Right Arbor Pulley (34") | E. Idler Pulley Arm |
| C. Idler Pulley | |

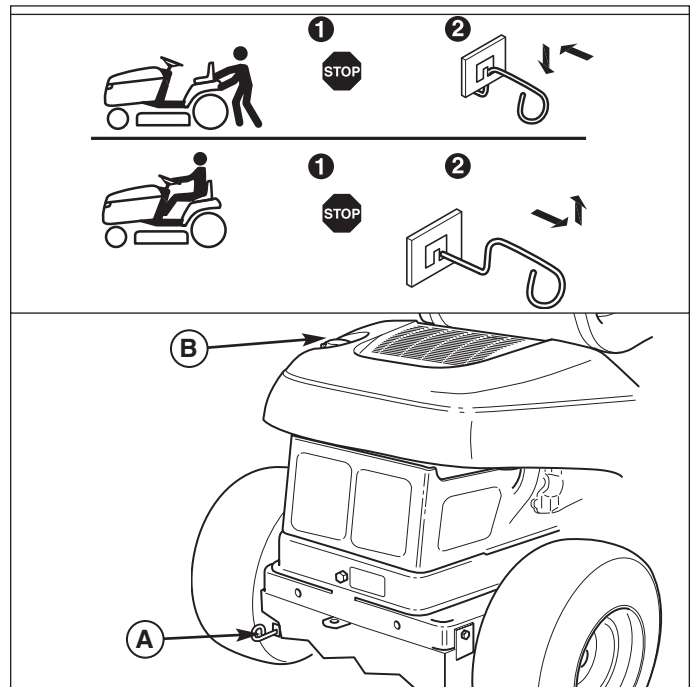

Figure 6. Transmission Release Lever

- | | |
|-------------------------------|------------------|
| A. Transmission Release Lever | B. Fuel Tank Cap |
|-------------------------------|------------------|

Operating the Rider

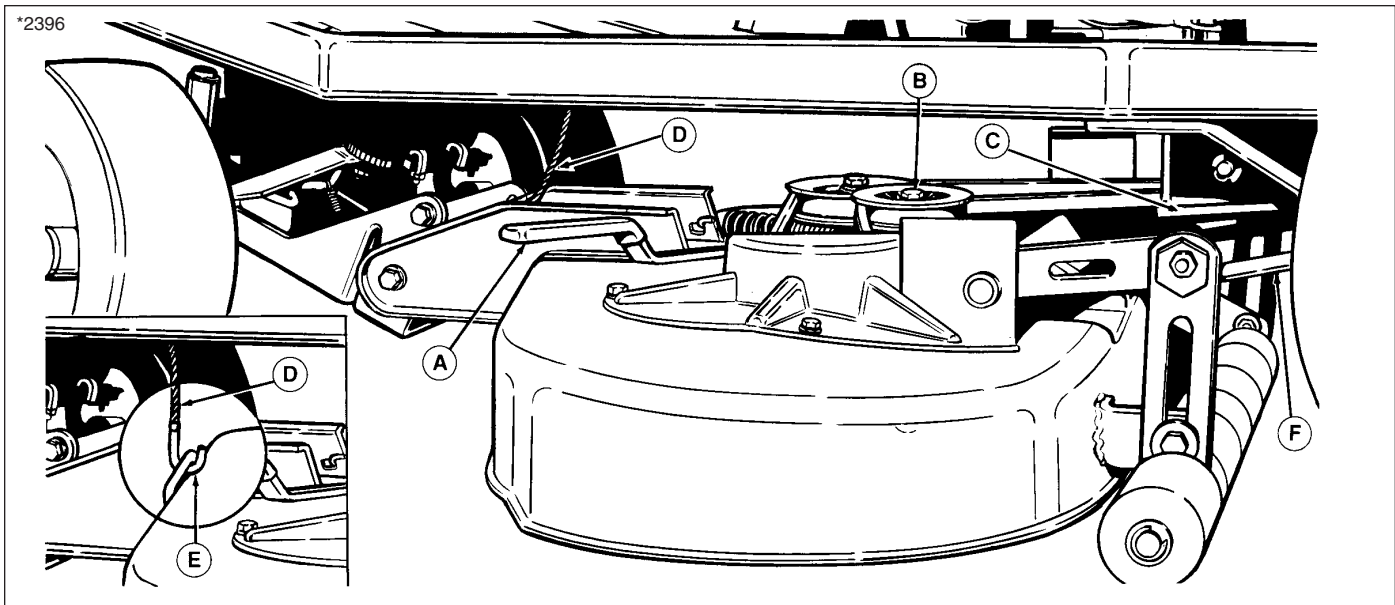

Figure 7. Mower Removal/Installation (34" mower shown)

- | | |
|---------------------------------|-----------------------|
| A. Idler Pulley Arm | D. Lift Cable |
| B. Idler Pulley | E. Lift Hook |
| C. PTO (Electric Clutch) Pulley | F. Rear Trailing Arms |

⚠ WARNING

Stop engine and remove key. Do not engage PTO until mower is completely removed or installed and operator is seated.

MOWER REMOVAL AND INSTALLATION

NOTE: Perform mower installation on a hard, level surface such as a concrete floor. For easier mower removal and installation, rear trailing arms (F, Figure 7) can be removed by removing spring clips and clevis pins.

1. Park rider and turn off PTO switch and engine, remove the key and apply parking brake. Turn the wheels fully to the left.
2. On left-hand side of 34" mower, push idler pulley arm (A, Figure 7) to relieve belt tension.
On right-hand side of 30" mower, pull idler pulley arm to relieve belt tension.
3. With belt tension relieved, remove belt from idler pulley (B, Figure 7) and PTO pulley (C). Removing belt relieves tension on the front hitch assembly.
4. With lift lever down and Dial-A-Cut™ control set to the lowest setting, remove lift cable (D, Figure 7) from mower hook (see inset illustration, Figure 7).

NOTE: Pull back slightly on the lift lever to allow easier turning of the Dial-A-Cut™ control.

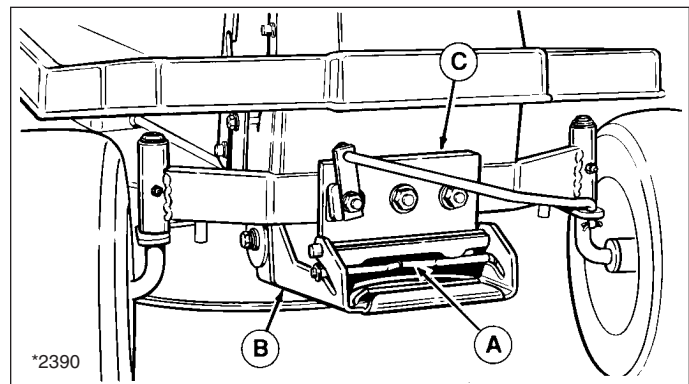

Figure 8. Mower Hitch

- | | |
|----------------|-------------------------|
| A. Lever | C. Rider Hitch Brackets |
| B. Mower Hitch | |

5. Remove mower hitch (B, Figure 8) from rider hitch brackets (C) by pulling spring-loaded lever (A) forward and lifting up on hitch. Place mower hitch on ground.
6. With wheels turned fully left, remove mower from underneath right-hand side of rider.
7. To install mower, reverse above steps. Check mower belt pattern (as shown in Figure 5). Make sure that the mower lift cable is installed with hook toward the rear (see Figure 7 inset) and rear trailing arms (F, Figure 7) are positioned above rear torsion bar.

STORAGE

WARNING

Never store the unit (with fuel) in an enclosed, poorly ventilated structure. Fuel vapors can travel to an ignition source (such as a furnace, water heater, etc.) and cause an explosion.

Fuel vapor is also toxic to humans and animals.

Before you store your unit for the off-season, read the "Maintenance and Storage" instructions in the SAFETY RULES AND INFORMATION section, then perform the following steps:

- Disengage the PTO, set the parking brake, & remove the key.
- Perform engine maintenance and storage measures listed in the Engine Manual. This includes draining the fuel system, or adding stabilizer to the fuel (do not store a fueled unit in an enclosed structure - see WARNING).

- Battery life will be increased if it is removed, put in a cool, dry place and fully charged about once a month. If the battery is left in the unit, disconnect the negative cable.

Before starting the unit after it has been stored:

- Check all fluid levels. Check all maintenance items.
- Perform all recommended checks and procedures found in the Engine Manual.
- Allow the engine to warm up for several minutes before use.

Regular Maintenance



MAINTENANCE SCHEDULE & PROCEDURES

The following schedule should be followed for normal care of your rider and mower.

SAFETY ITEMS	Before Each Use	Every 5 Hours	Every 25 Hours	Every 100 Hours	Every 250 Hours	Spring & Fall
Check Safety Interlock System						•
Check Tractor Brakes						•
Check Mower Blade Stopping Time				•		•
TRACTOR MAINTENANCE ITEMS	Before Each Use	Every 5 Hours	Every 25 Hours	Every 100 Hours	Every 250 Hours	Spring & Fall
Check Tractor/Mower for loose hardware		•				
Lubricate Rear Axle Shafts						Yearly
Clean Battery & Cables				•		
Check Tire Pressure			•			
Clean Deck & Check/Replace Mower Blades**				•		
Lubricate Rider & Mower				• ***		
Transmission Maintenance ****						
ENGINE MAINTENANCE ITEMS	Before Each Use	Every 5 Hours	Every 25 Hours	Every 100 Hours	Every 250 Hours	Spring & Fall
Check Engine Oil Level	•					
Check / Change Engine Air Filter *						
Change Engine Oil & Filter *						
Inspect Spark Plug(s) *						
Check / Replace Fuel Filter *						

* Refer to engine owner's manual. Change original engine oil after initial break-in period.

** More often in hot (over 85° F: 30° C) weather or dusty operating conditions.

*** Service after the first 50 hours of operation, then every 250 hours of operation.

**** Service after the first 25 hours of operation, then every 250 hours of operation.

***** See you dealer.

CHECK TIRE PRESSURES

Tire Pressure should be checked periodically, and maintained at the levels shown in the chart. Note that these pressures may differ slightly from the "Max Inflation" stamped on the side-wall of the tires. The pressures shown provide proper traction, improve cut quality, and extend tire life.

Tire	Pressure
Front	10-12 psi (.68 - .82 bar)
Rear	10-12 psi (.68 - .82 bar)

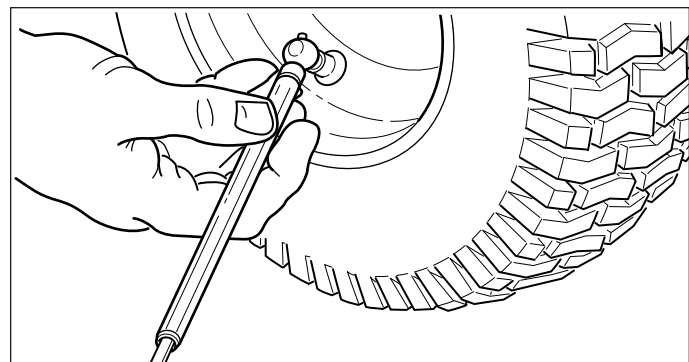

Figure 9. Checking Tire Pressure

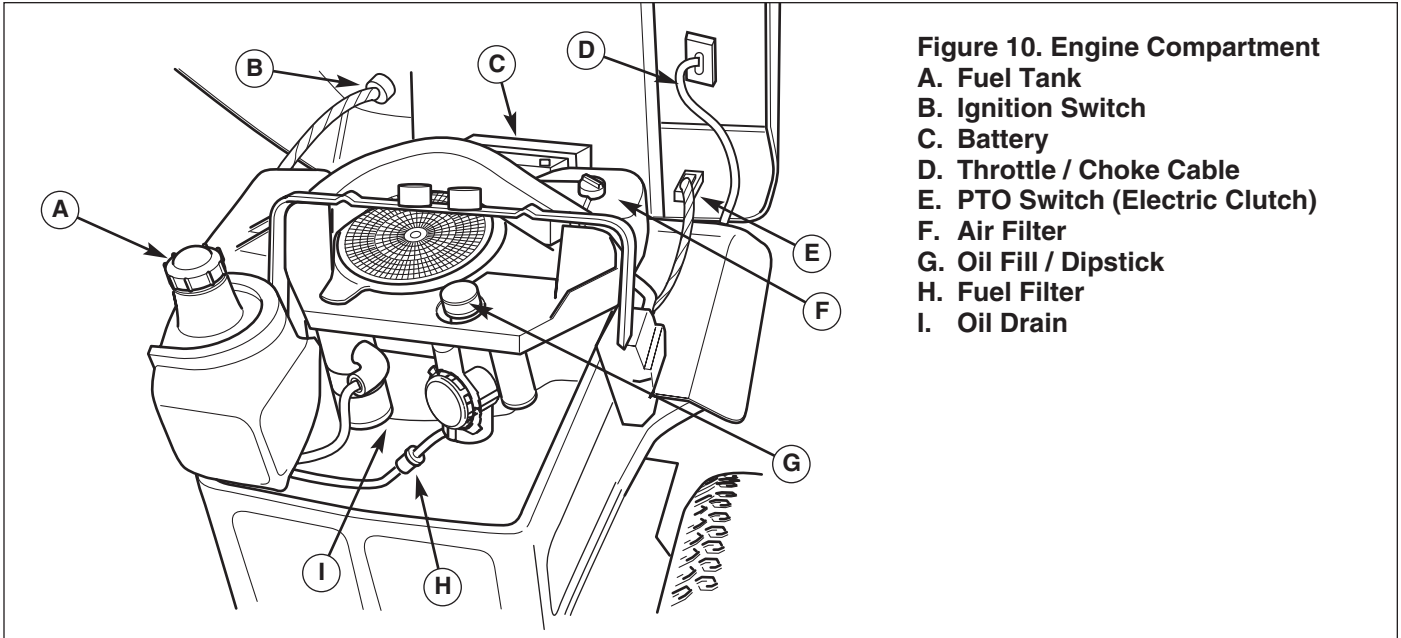

Figure 10. Engine Compartment
A. Fuel Tank
B. Ignition Switch
C. Battery
D. Throttle / Choke Cable
E. PTO Switch (Electric Clutch)
F. Air Filter
G. Oil Fill / Dipstick
H. Fuel Filter
I. Oil Drain

RAISING THE SEAT DECK

To gain access to the engine compartment, simply tilt the seat deck forward.

ADDING FUEL

To add fuel:

1. Remove the fuel cap (A, Figure 10).
2. Fill the tank. Do not overfill. Leave room in the tank for fuel expansion. Refer to your Engine Manual for specific fuel recommendations.
3. Install and hand tighten the fuel cap.

FUEL FILTER

The fuel filter is located in fuel line between fuel tank and carburetor. If filter is dirty or clogged, replace as follows. Place a container below filter to catch spilled gasoline.

1. Using a pliers, open and slide hose clamps from fuel filter.
2. Remove hoses from filter.
3. Install new filter in proper flow direction in fuel line. Secure with hose clamps. See warning at beginning of procedure.

OIL & FILTER CHANGE

Refer to Engine Manual.

CHECK / CHANGE AIR FILTER

Refer to Engine Manual.

REPLACE SPARK PLUG

Refer to Engine Manual.



Do not use gasoline containing METHANOL, gasohol containing more than 10% ethanol, gasoline additives, premium gasoline, or white gas because engine/fuel system damage could result.

WARNING

Gasoline is highly flammable and must be handled with care. Never fill the tank when the engine is still hot from recent operation. Do not allow open flame, smoking or matches in the area. Avoid over-filling and wipe up any spills.

Do not remove fuel filter when engine is hot, as spilled gasoline may ignite. DO NOT spread hose clamps further than necessary. Ensure clamps grip hoses firmly over filter after installation.

Regular Maintenance

LUBRICATION

Lubricate the rider and mower as shown in Figures 11 - 16. When a grease gun is shown, wipe the fitting clean, apply two or three shots of lithium base automotive grease, and wipe off excess grease. When an oil can is shown, wipe the area clean, apply a few drops of oil (SAE 30), then wipe up drips or spills.

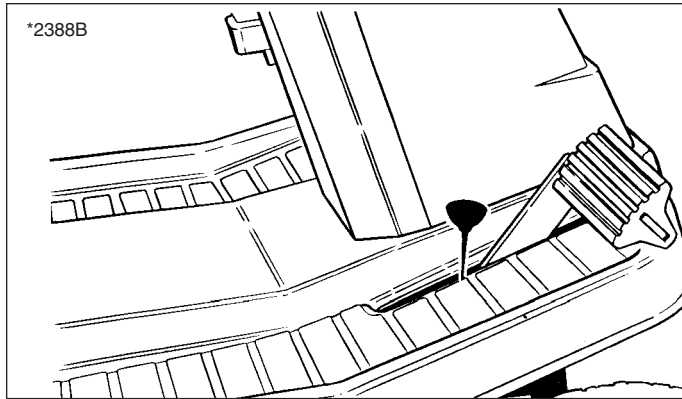

Figure 11. Brake Pedal Pivot Point

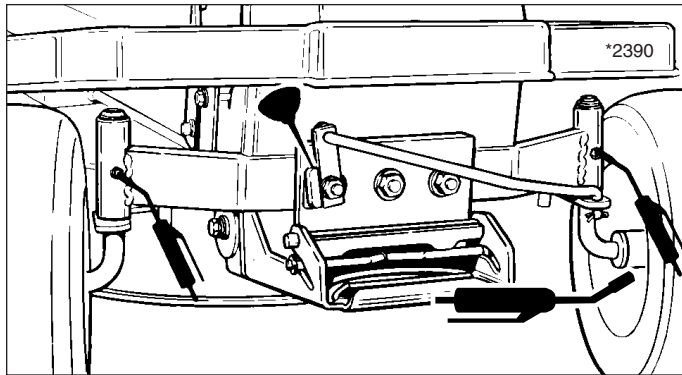

Figure 12. Front Axle Lubrication Points

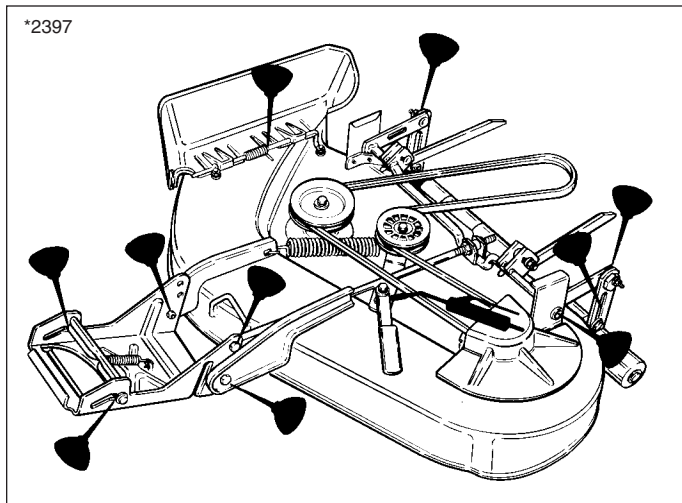

Figure 13. Mower Deck Lubrication Points

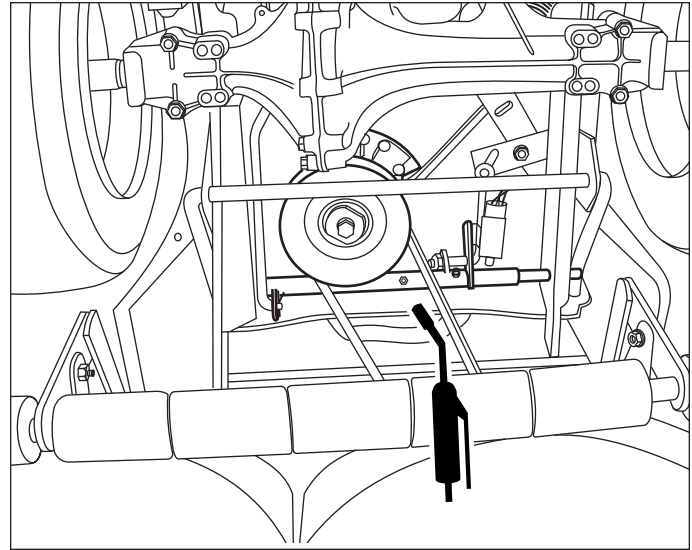

Figure 14. Rider Lubrication Points - Rear Half (Gear Model Shown)

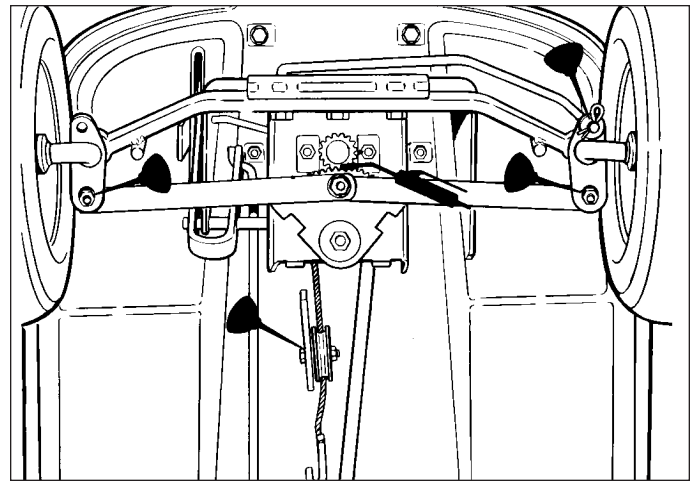

Figure 15. Rider Lubrication Points - Front Half

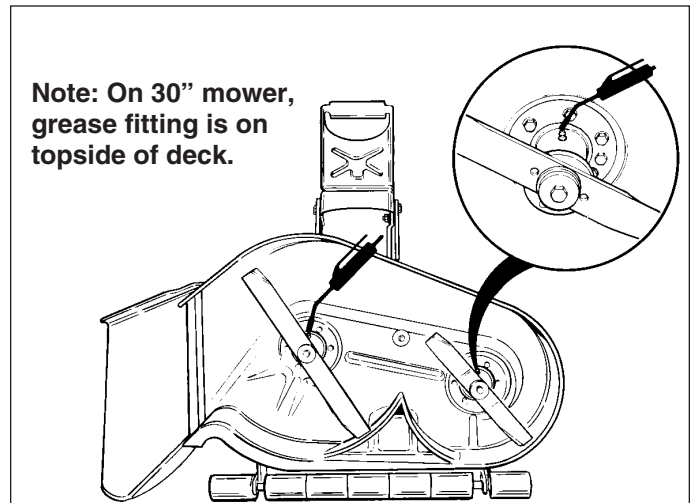

Figure 16. Arbor Lubrication Points

BATTERY MAINTENANCE

⚠ WARNING

When removing or installing battery cables, disconnect the negative cable **FIRST** and reconnect it **LAST**. If not done in this order, the positive terminal can be shorted to the frame by a tool.

Cleaning the Battery and Cables

Service Interval: Every 100 Hours

1. Disconnect the cables from the battery, negative cable first (A, Figure 17).
2. Remove the battery hold-down (C) and battery.
3. Clean the battery compartment with a solution of baking soda and water.
4. Clean the battery terminals and cable ends with a wire brush and battery terminal cleaner until shiny.
5. Reinstall the battery in the battery compartment, and secure with the battery hold down (C).
6. Reattach the battery cables, positive cable first (B).
7. Coat the cable ends and battery terminals with petroleum jelly or non-conducting grease.

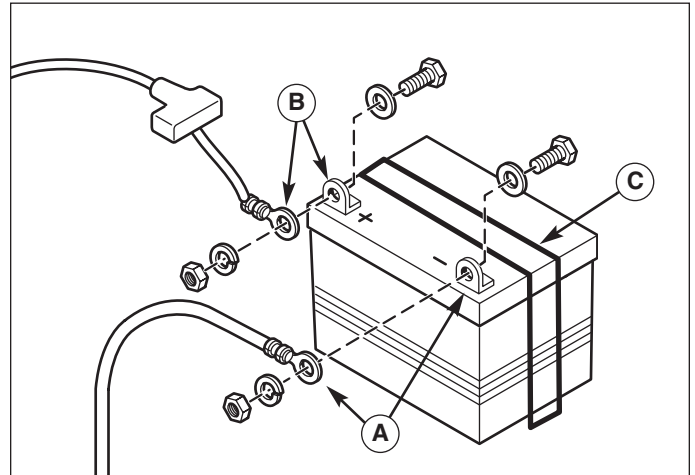

Figure 17. Battery

- A. Negative Battery Terminal & Cable**
- B. Positive Battery Terminal & Cable**
- C. Hold Down Strap**

LUBRICATE REAR AXLE SHAFTS

Service Interval: Yearly

We recommend removing the rear wheel hubs and lubricating the axle shafts yearly. This prevents the wheel hubs from seizing onto the axle shaft and makes future service easier.

1. Turn off the ignition, turn off the PTO, engage the parking brake, and block the front tires.
2. Using a jack or chain hoist positioned at the center of the rear frame, carefully jack the unit up until the rear tires are approximately 1" - 2" (2.5-5 cm) off the ground.

NOTE: For overall unit stability during service, do not jack rear end higher than required for wheel removal.

3. Support the rear of the unit on jackstands positioned under the rear frame.

NOTE: Your axle assembly may differ slightly from the assembly pictured: the quantity of washers is adjusted on a tractor by tractor basis during assembly to allow a small amount of axle end-play.

4. Remove the hardware retaining the wheel assembly to the axle and lubricate the axle shaft using anti-seize compound or lithium grease.
5. Reinstall the components in reverse order of disassembly and lower the unit. Be sure the key (A, Figure 18) is in place in the axle keyway.

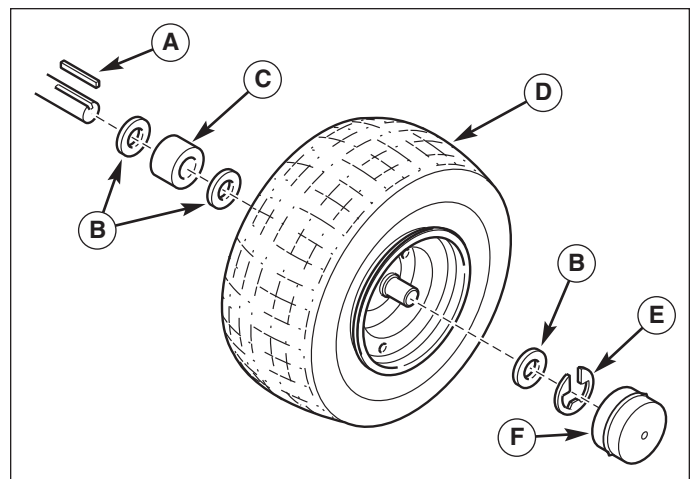

Figure 18. Rear Axle Hardware

- A. Key**
- B. Washer**
- C. Spacer**
- D. Wheel & Hub**
- E. Retaining Ring**
- F. Axle Cap**

Regular Maintenance

SERVICING THE MOWER BLADES

⚠ WARNING

For your personal safety, do not handle the sharp mower blades with bare hands. Careless or improper handling of blades may result in serious injury.

1. Remove mower from the rider.
2. Blades should be sharp and free of nicks and dents. If not, sharpen blades as described in following steps.
3. To remove blade for sharpening, use wooden block to hold blade while removing the blade mounting cap-screw (Figure 19).
4. Use a file to sharpen blade to fine edge. Remove all nicks and dents in blade edge. If blade is severely damaged, it should be replaced.
5. Balance the blade as shown in Figure 20. Center the blade's hole on a nail lubricated with a drop of oil. A balanced blade will remain level.
6. Reinstall each blade with the tabs pointing up toward deck as shown in Figure 21. Secure with a capscrew (D), cup washer (C) and hex washer (B). Use a wooden block (A) to prevent blade rotation and torque capscrews to 45-55 ft-lbs (61-75 Nm).

⚠ WARNING

For your personal safety, blade mounting capscrews must each be installed with a hex washer and spring washer, then securely tightened. Torque blade mounting capscrew to 45-55 ft-lbs (61-75 N-m.)

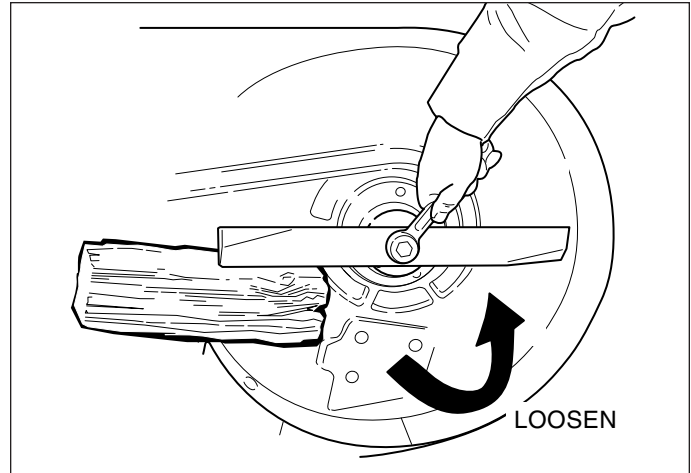

Figure 19. Removing The Blade

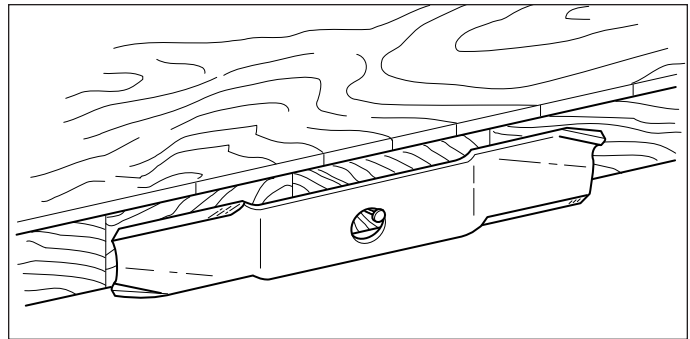

Figure 20 Balancing The Blade

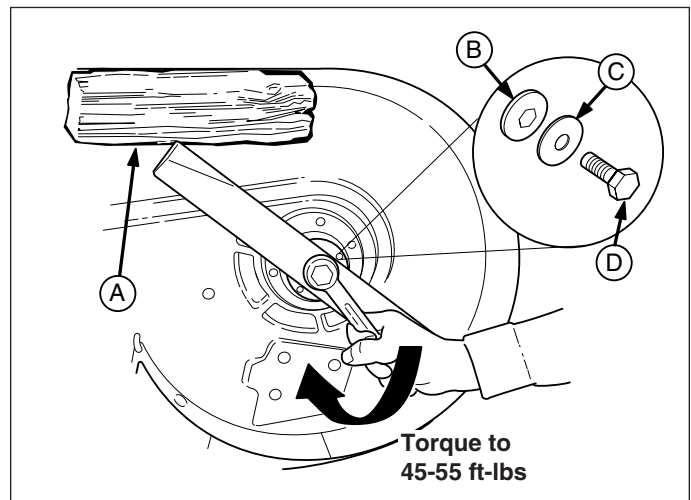

Figure 21. Installing The Blade

- | | |
|-----------------|---------------|
| A. Wooden Block | C. Cup Washer |
| B. Hex Washer | D. Capscrew |



Troubleshooting Adjustments & Service

TROUBLESHOOTING

While normal care and regular maintenance will extend the life of your equipment, prolonged or constant use may eventually require that service be performed to allow it to continue operating properly.

The troubleshooting guide below lists the most common problems, their causes and remedies.

See the information on the following pages for instructions on how to perform most of these minor adjustments and service repairs yourself. If you prefer, all of these procedures can be performed for you by your local authorized dealer.

WARNING

To avoid serious injury, perform maintenance on the tractor or mower only when the engine is stopped and the parking brake engaged.

Always remove the ignition key, disconnect the spark plug wire and fasten it away from the plug before beginning the maintenance, to prevent accidental starting of the engine.

TROUBLESHOOTING THE RIDER

PROBLEM	CAUSE	REMEDY
Engine will not turnover or start.	<ol style="list-style-type: none"> Ground speed control lever not in neutral-start position. PTO (electric clutch) switch in ON position. Out of fuel. Engine flooded. Circuit breaker tripped. Battery terminals require cleaning. Battery discharged or dead. Wiring loose or broken. Solenoid or starter motor faulty. Safety interlock switch faulty. Spark plug(s) faulty, fouled or incorrectly gapped. Water in fuel. Old stale gas. Brake pedal not depressed. 	<ol style="list-style-type: none"> Shift into neutral. Place in OFF position. If engine is hot, allow it to cool, then refill the fuel tank. Open the CHOKE. Wait one minute for automatic reset. Replace if defective (see your dealer). See "Normal Care" section. Recharge or replace. Visually check wiring & replace broken or frayed wires. Tighten loose connections. Repair or replace. (See your dealer.) Replace if needed. (See your dealer.) Clean and gap or replace. See Engine Manual. Drain fuel & refill with fresh fuel. Drain fuel & replace with fresh fuel. Depress pedal.
Engine starts hard or runs poorly.	<ol style="list-style-type: none"> Fuel mixture too rich. Carburetor adjusted incorrectly. Spark plug(s) faulty, fouled, or incorrectly gapped. 	<ol style="list-style-type: none"> Open the CHOKE. If problem persists, clean the air filter. (See Engine Manual.) See Engine Manual. Clean & gap or replace. See Engine Manual.
Engine knocks.	<ol style="list-style-type: none"> Low oil level. Using wrong grade oil. 	<ol style="list-style-type: none"> Check/add oil as required. See Engine Manual.
Excessive oil consumption.	<ol style="list-style-type: none"> Engine running too hot. Using wrong weight oil. Too much oil in crankcase. 	<ol style="list-style-type: none"> Clean engine fins, blower screen and air cleaner. See Engine Manual. Drain excess oil.
Engine exhaust is black.	<ol style="list-style-type: none"> Dirty air filter. Choke not fully open. 	<ol style="list-style-type: none"> Clean air filter. See Engine Manual. Open CHOKE. If problem persists, check air filter and carburetor adjustments. See Engine Manual.

Troubleshooting, Adjustments & Service

Troubleshooting the Rider (Continued)

PROBLEM	CAUSE	REMEDY
Engine runs, but rider will not drive.	<ol style="list-style-type: none"> 1. Ground speed control lever in neutral. 2. Transmission release lever in "push" position. 3. Belt is broken. 4. Drive belt slips. 5. Brake is not fully released. 	<ol style="list-style-type: none"> 1. Shift in forward or reverse. 2. Move into drive position. 3. See "Drive Belt Replacement." 4. See problem and cause below. 5. See "Brake Adjustment."
Rider drive belt slips.	<ol style="list-style-type: none"> 1. Clutch is out of adjustment. 2. Pulleys or belt greasy or oily. 3. Belt stretched or worn. 4. Idler pulley pivot bracket "frozen" in declutched position. 	<ol style="list-style-type: none"> 1. See your dealer. 2. Clean as required. 3. Replace with correct belt. 4. Remove idler pulley, clean and lubricate.
Brake will not hold.	<ol style="list-style-type: none"> 1. Brake is incorrectly adjusted. 2. Internal brake disc on transaxle worn. 	<ol style="list-style-type: none"> 1. See "Brake Adjustment." 2. See your dealer.
Rider steers hard or handles poorly.	<ol style="list-style-type: none"> 1. Steering linkage is loose. 2. Improper tire inflation. 3. Spindle bearings dry. 	<ol style="list-style-type: none"> 1. Check and tighten any loose connections. See "Steering Gear Adjustment." 2. Check and correct. 3. Grease spindles. See "Lubricating the Rider."

TROUBLESHOOTING THE MOWER

PROBLEM	CAUSE	REMEDY
Mower will not raise.	<ol style="list-style-type: none"> 1. Lift cable not properly attached or damaged. 	<ol style="list-style-type: none"> 1. Attach or repair.
Mower cut is uneven.	<ol style="list-style-type: none"> 1. Mower not leveled properly. 2. Rider tires not inflated equally or properly. 	<ol style="list-style-type: none"> 1. See "Mower Adjustment." 2. See "Normal Care."
Mower cut is rough looking.	<ol style="list-style-type: none"> 1. Engine speed too slow. 2. Ground speed too fast. 3. Blades dull and require sharpening. 4. Mower drive belt slipping. 5. Check PTO (Electric Clutch) Adjustment. 6. Blades not properly fastened. 	<ol style="list-style-type: none"> 1. Set to full speed. 2. Set ground speed control lever at a slower ground speed. 3. See "Servicing the Mower Blades." 4. Belt oily or worn. Clean or replace belt as necessary. 5. Clutch may need to be adjusted. 6. See "Servicing the Mower Blades." to arbors.
Engine stalls easily with mower engaged.	<ol style="list-style-type: none"> 1. Engine speed too slow. 2. Ground speed too fast. 3. Carburetor not adjusted properly. 4. Cutting height set too low when mowing tall grass. 5. Discharge chute jamming with cut grass. 	<ol style="list-style-type: none"> 1. Set for 3/4 to full throttle. 2. Reduce ground speed. 3. Adjust carburetor. (See Engine Manual.) 4. Cut tall grass at maximum cutting height during first pass. 5. Cut grass with discharge pointing toward previously cut area.
Excessive mower vibration.	<ol style="list-style-type: none"> 1. Blade mounting screws are loose. 2. Mower blade(s), arbors, or pulleys are bent. 3. Mower blade(s) out of balance. 4. Belt installed incorrectly. 	<ol style="list-style-type: none"> 1. Tighten to 45-55 ft-lbs (61-75 Nm). 2. Check and replace as necessary. 3. Remove, sharpen and balance blade(s). See "Servicing the Mower Blade(s)." 4. See "Belt Replacement."
Excessive belt breakage.	<ol style="list-style-type: none"> 1. Bent or rough pulleys. 2. Using incorrect belt. 	<ol style="list-style-type: none"> 1. Repair or replace. 2. See your dealer.
Mower drive belt slips or fails to drive.	<ol style="list-style-type: none"> 1. Idler pulley spring broken or not properly attached. 2. Mower drive belt broken. 	<ol style="list-style-type: none"> 1. See your dealer. 2. Replace.

WARNING

To avoid serious injury, perform adjustments only with engine stopped, key removed and rider on level ground.

SEAT ADJUSTMENT

Use the lever on the front of the seat (A, Figure 22) on to adjust the seat forward or rearward for best rider comfort.

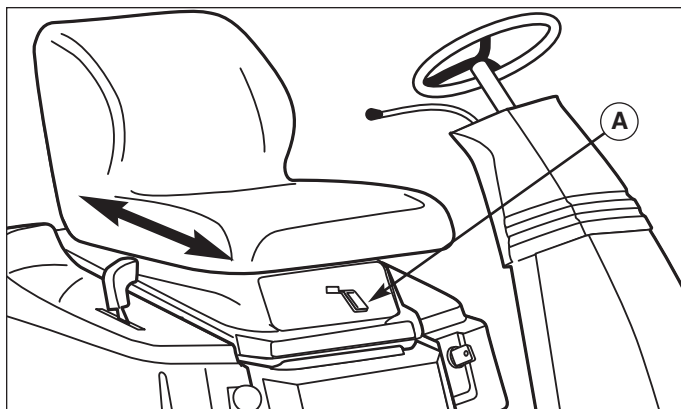

Figure 22. Seat Adjustment
A. Seat Adjustment Lever

STEERING GEAR ADJUSTMENT

If there is excessive slack in the steering system, the steering gear can be re-indexed to the steering shaft.

1. See Figure 23. Loosen the two capscrews (A) and push bracket so that gear teeth are closely meshed.
2. Tighten nuts after adjustment to 35 - 40 ft-lbs.

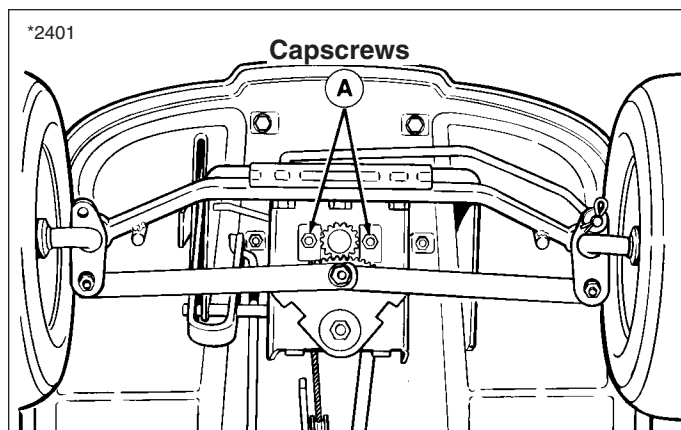

Figure 23. Steering Gear Adjustment
A. Capscrews

STEERING WHEEL ADJUSTMENT

Your unit is equipped with a dual position steering shaft to allow for steering wheel adjustment for rider comfort.

1. Pull down on the rubber boot to expose the two holes in the steering shaft (A, Figure 24).
2. Use a suitable drift to remove the roll pin at the base of the steering wheel.
3. Align the hole in the steering wheel with the appropriate steering shaft hole and install the roll pin.

NOTE: Steering wheel is factory installed with the roll pin in the bottom hole.

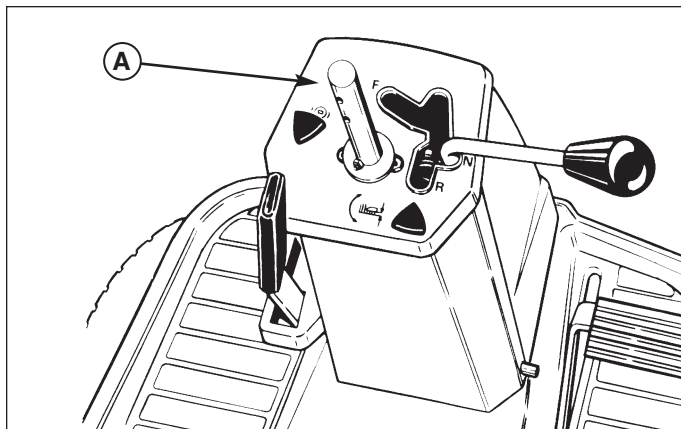

Figure 24. Steering Wheel Height Adjustment
A. Steering Shaft

Troubleshooting, Adjustments & Service

BRAKE ADJUSTMENT

Brake Adjustment

1. Release the parking brake.
2. Brake arm (C, Figure 25) should be touching stop (B).
3. Remove cotter pin (D) and loosen the castle nut (A). Place a 0.015" feeler gauge (E) gap between the brake disc (F) and the brake puck (G).
 - a. To decrease gap, insert feeler gauge in gap and turn nut (A) clockwise until resistance is felt on the feeler gauge. To increase gap, turn nut (A) counterclockwise and recheck gap.
 - b. Back off nut (counter-clockwise) until the nearest slot is aligned with hole in threads. Replace cotter pin.
4. Set the parking brake. Loosen or tighten adjustment nut (H) to achieve a 1-5/8" - 1-3/4" compressed spring length as shown in Figure 25.

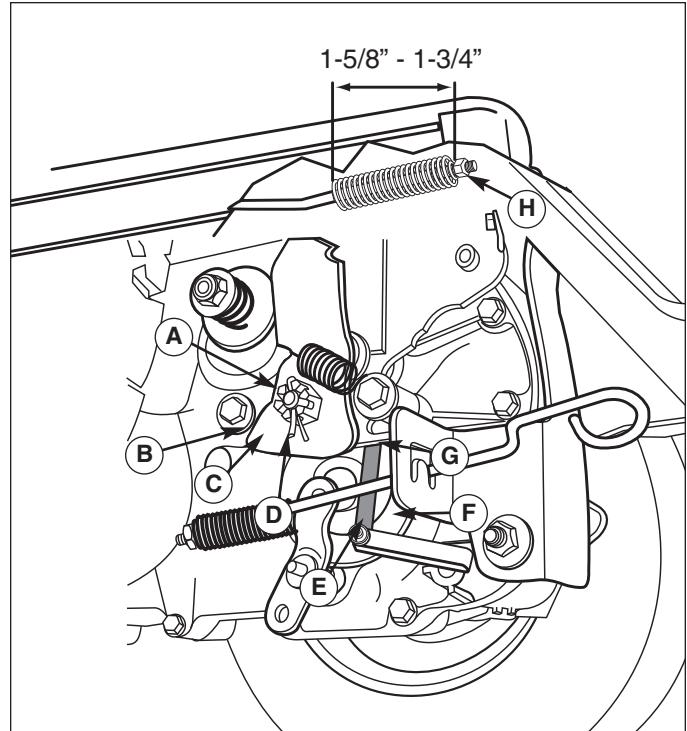

BLADE BRAKE CHECK

Mower blades and mower drive belt should come to a complete stop within five seconds after electric PTO switch is turned off.

1. With rider in neutral, PTO disengaged and operator in seat, start the rider engine.
2. Look over the left-hand footrest at the mower drive belt. Engage the PTO and wait several seconds. Disengage the PTO and check the amount of time it takes for the mower drive belt to stop.
3. If mower drive belt does not stop within five seconds, see your dealer.

Figure 25. Brake Adjustment

- | | |
|----------------------|--------------------------|
| A. Castle Nut | E. Feeler Gauge |
| B. Stop | F. Brake Disc |
| C. Brake Arm | G. Brake Puck |
| D. Cotter Pin | H. Adjustment Nut |

MOWER ADJUSTMENTS

If the cut is uneven, the mower may need leveling. Unequal or improper tire pressure may also cause an uneven cut. Make sure tire pressure is correct as specified in Checking Tire Pressure. To achieve proper mower leveling, perform Side-To-Side Leveling, Front-To-Back Leveling and Transport Height Adjustment procedures, in order, as follows.

Side-To-Side Leveling

1. With the mower installed, place the rider on a smooth, level surface such as a concrete floor. Turn the front wheels straight forward.
2. Check for bent blades and replace if necessary.
3. Loosen nut (C, Figure 26) so trailing arms are loose. Mower must be resting on rollers with no weight on trailing arms.
4. Use the Dial-A-Cut™ Control (E, Figure 27) and place mower in mid-cut position by aligning front edge of mower lift lever (A) with number 2 or 3 on quadrant scale. Make sure mower lift lever is in down position.
5. Make sure rear rollers (C, Figure 28) are on the ground. If not, refer to Transport Height Adjustment.

NOTE: If rollers do not rest on the ground and it is necessary to perform transport height adjustment, it is necessary to perform transport height adjustment again after all leveling procedures are completed.

6. Position blade(s) side-to-side and measure distance from outside tip of blade(s) to ground. Measurement should be equal (within 1/8").
7. See Figure 28. On left side of mower, make sure eccentric nut is in correct position as shown. Loosen outside nut (A) and rotate eccentric nut (B) so that flat side with hole closest to it is towards the rear. Tighten outside nut (A) while holding eccentric nut (B).
8. On right side of mower, loosen outside nut (A). Turn eccentric nut (B) counterclockwise to raise side of mower, or clockwise to lower right hand side of mower.

NOTE: Do not turn eccentric nut more than 1/4 turn in either direction. When adjusted beyond 1/4 turn, nut will move mower in opposite direction than when starting adjustment.

9. When adjustment is correct, hold eccentric nut (B) and tighten nut (A) to 30 ft-lbs. Check measurement on both sides of mower.

⚠ WARNING

Before checking mower, shut off PTO and engine. Allow all moving parts to stop. Remove ignition key, then disconnect the spark plug wire and fasten it away from the spark plug.

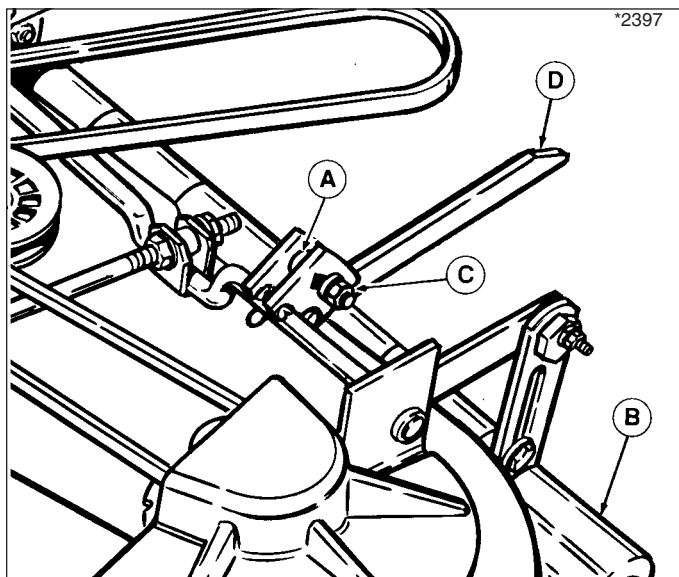

Figure 26. Trailing Arms

- | | |
|-----------------------|-----------------------|
| A. Spacers | C. Nut |
| B. Rear Mower Rollers | D. Rear Trailing Arms |

⚠ WARNING

Mower blades are sharp. Turn the mower drive belt to rotate blades into position or wear protective gloves to protect against injury.

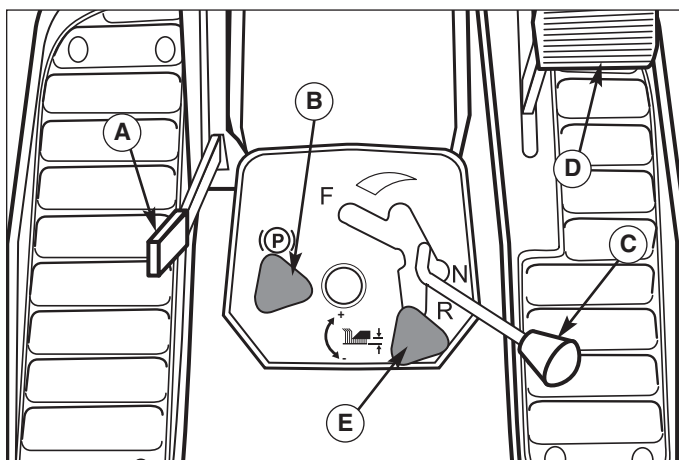

Figure 27. Controls

- | | |
|-------------------------------|------------------------|
| A. Mower Lift Lever | D. Clutch/Brake Pedal |
| B. Parking Brake Knob | E. Dial-A-Cut™ Control |
| C. Ground Speed Control Lever | |

Troubleshooting, Adjustments & Service

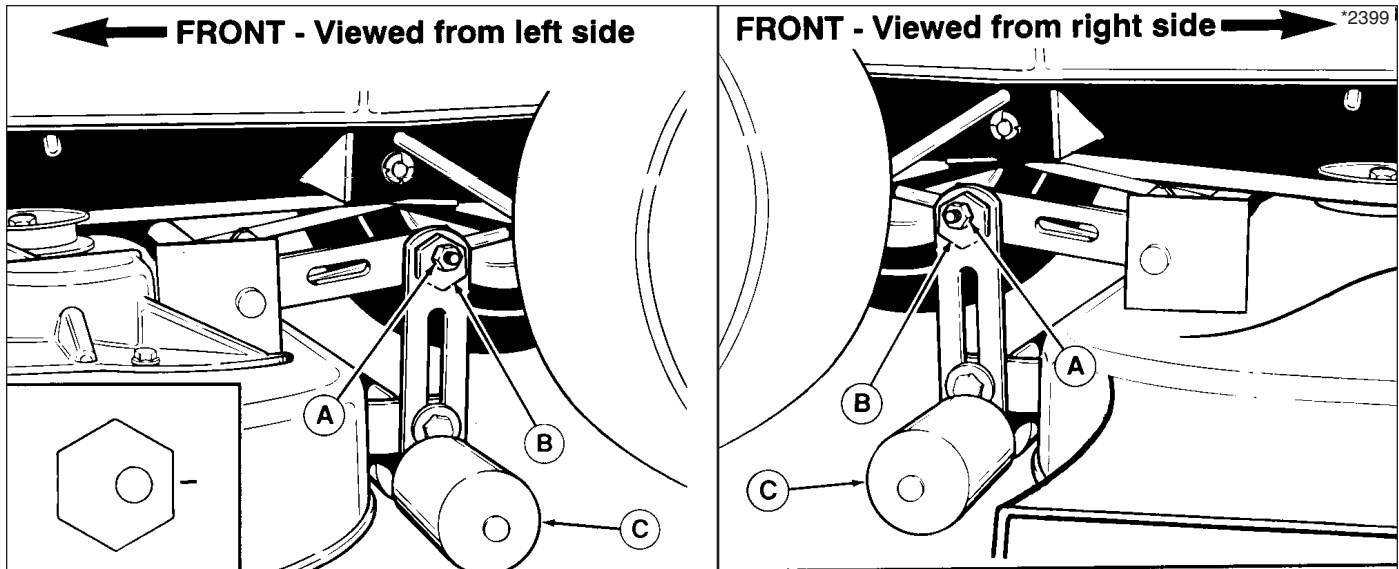
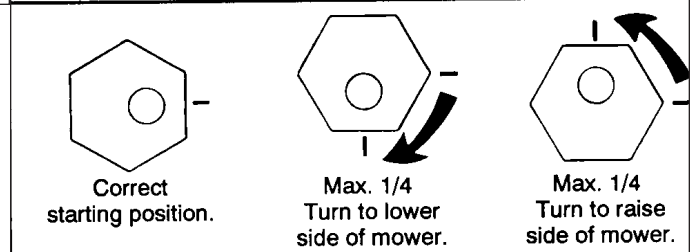

Figure 28. Leveling The Mower Side-to-Side

- A. Nut**
- B. Eccentric Nut**
- C. Rear Rollers**



Front-To-Back Leveling

1. Make sure mower is level side-to-side and that rear rollers are on the ground.
2. Position blade(s) front-to-back. Measure the distance from the ground to front tip of blade(s), and from ground to rear tip of blade(s).

On 30" mower, the front tip should be level to 1/8" (3 mm) higher than rear tip.

On 34" mower, the front tips should be 1/4" (6 mm) higher than the rear tips.

3. See Figure 29. Loosen jam nut (E). To lower rear of mower deck, loosen nut (B) which will lengthen leveling rod (D). To raise rear of deck, shorten leveling rod (D). When proper measurement is obtained, tighten nut (A) against bracket, then tighten jam nut (E) against nut (A).

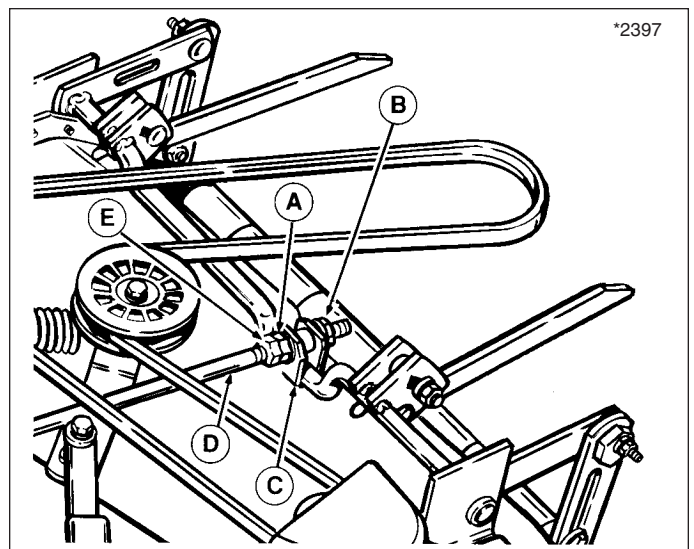

Figure 29. Front-To-Back Levelling

- A. Adjustment Nut**
- B. Rear Nut**
- C. Bracket**
- D. Levelling Rod**
- E. Jam Nut**

Transport Height Adjustment

Transport height should be adjusted so that rear mower rollers are 1/8" - 1/4" (3-6 mm) above ground when mower lift lever is in transport position. To adjust, perform both mower leveling procedures first, then do the following procedure.

See Figure 30.

1. Park rider on a flat level surface.
2. Adjust Dial-A-Cut™ control so that front edge of mower lift lever is aligned with 2-3/4" mark (34" mower) or at 3" mark (30" mower) on the quadrant scale.
3. Loosen nut (C) and position spacer (A) against rear trailing arms (D). Position both the left and right side spacers against trailing arms.
4. Tighten nut (C) securely.
5. Place mower lift lever in transport position. Rear mower rollers should be 1/8" - 1/4" off ground. If not, repeat Steps 2 - 4.

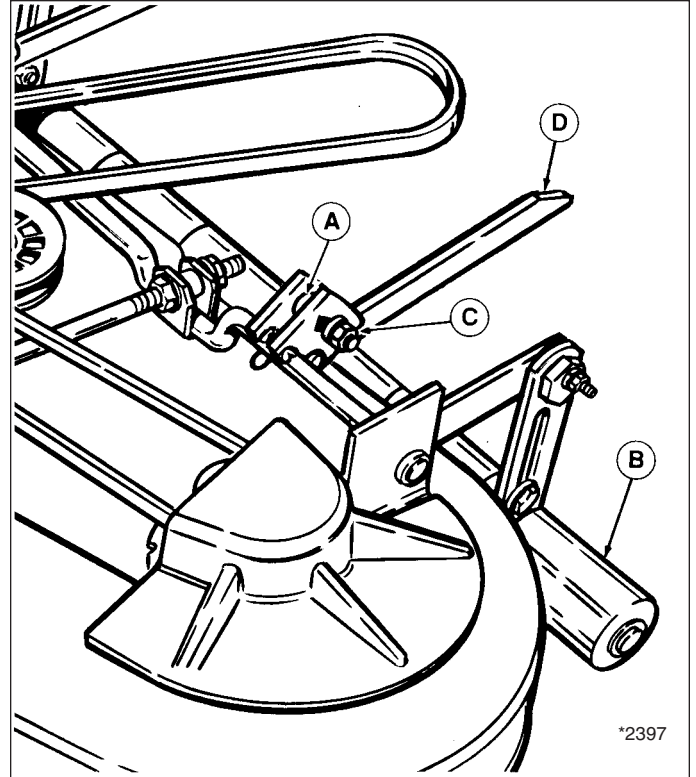

Figure 30. Transport Height Adjustment

A. Spacers
B. Rear Mower Rollers
C. Nut
D. Rear Trailing Arms

BATTERY CHARGING

WARNING

Keep open flames and sparks away from the battery; the gases coming from it are highly explosive. Ventilate the battery well during charging.

A dead battery or one too weak to start the engine may be the result of a defect in the charging system or other electrical component. If there is any doubt about the cause of the problem, see your dealer. If you need to replace the battery, follow the steps under "Cleaning the Battery & Cables" in the REGULAR MAINTENANCE section.

To charge the battery, follow the instructions provided by the battery charger manufacturer, as well as, all warnings included in the safety rules sections of this book. Charge the battery until fully charged (until the specific gravity of the electrolyte is 1.250 or higher and the electrolyte temperature is at least 60° F). Do not charge at a rate higher than 10 amps.

Troubleshooting, Adjustments & Service

 To avoid damaging belts, DO NOT PRY BELTS OVER PULLEYS.

RIDER DRIVE BELT REPLACEMENT

Replacement of the rider drive belt requires removal of the transmission and carrier frame. Should the drive belt ever fail, contact your dealer for replacement.

MOWER BELT REPLACEMENT - 30"

See Figure 31.

1. Mower does not need to be removed to install a new belt. However, for easier access, mower can be removed following steps in "Mower Removal and Installation."
2. If mower is not removed, place mower in lowest cutting position. Pull idler pulley arm (A) towards you to relieve belt tension. Remove belt from idler pulley (B) and center arbor pulley (C).
3. Remove belt from front idler pulley (D) and PTO pulley (E).
4. Replace old belt with new belt. Make sure V-side of belt runs in all pulley grooves except for idler pulley (B). Check belt pattern as shown.
5. Install mower if it was removed, and install belt on PTO pulley (E).

MOWER BELT REPLACEMENT - 34"

See Figure 32.

1. Mower does not need to be removed to install a new belt. However, for easier access, mower can be removed following steps in "Mower Removal and Installation."
2. If mower is not removed, place mower in lowest cutting position. Push idler pulley arm (A, Figure 32) away from you to relieve belt tension. Remove belt from idler pulley (B) and PTO pulley (C).
3. Remove the three capscrews (D, Figure 31) securing the left-hand arbor cover.
4. Remove old belt from arbor pulleys and replace with new belt. Make sure V-side of belt runs in all arbor pulley grooves and flat side of belt runs against idler pulley. See Figure 33 for belt pattern.
5. Install mower if it was removed, and install belt to PTO pulley (C, Figure 32). Push idler arm and install belt around idler pulley.

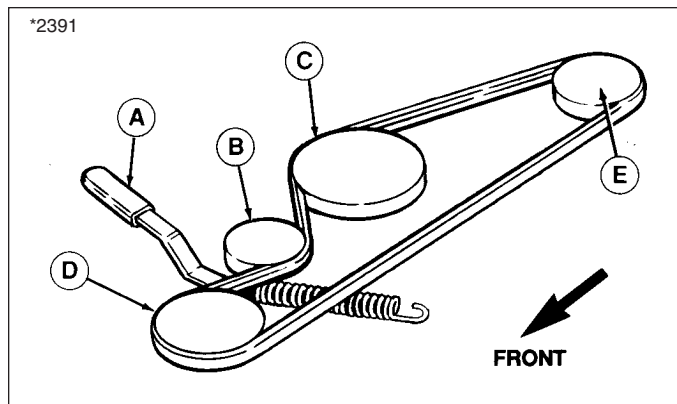

Figure 31 Belt Pattern - 30" Mower

- | | |
|------------------------|---------------------------------|
| A. Idler Pulley Arm | D. Front Idler Pulley |
| B. Idler Pulley | E. PTO Pulley (Electric Clutch) |
| C. Center Arbor Pulley | |

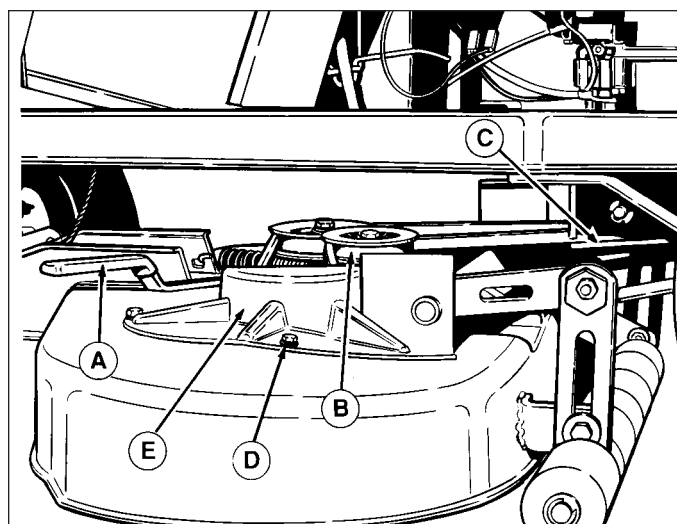

Figure 32. Mower Belt Replacement - 34"

- | | |
|---------------------|----------------|
| A. Idler Pulley Arm | D. Capscrews |
| B. Idler Pulley | E. Arbor Cover |
| C. PTO Pulley | |

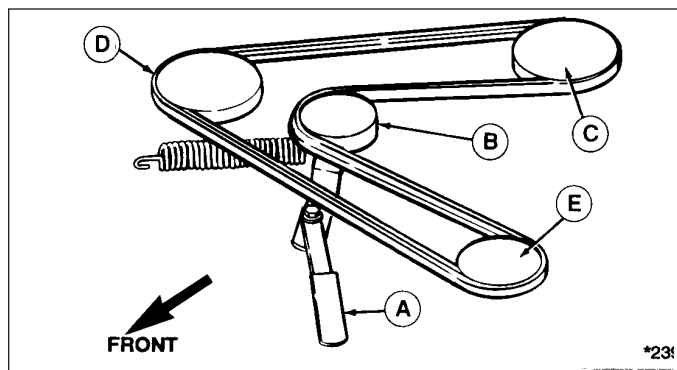

Figure 33. Belt Pattern - 34" Mower

- | | |
|---------------------|-----------------------|
| A. Idler Arm Pulley | D. Right Arbor Pulley |
| B. Idler Pulley | E. Left Arbor Pulley |
| C. PTO Pulley | |



Specifications

NOTE: Specifications are correct at time of printing and are subject to change without notice.

** The gross power rating for individual gas engine models is labeled in accordance with SAE (Society of Automotive Engineers) code J1940 (Small Engine Power & Torque Rating Procedure), and rating performance has been obtained and corrected in accordance with SAE J1995 (Revision 2002-05). Torque values are derived at 3060 RPM; horsepower values are derived at 3600 RPM. Actual gross engine power will be lower and is affected by, among other things, ambient operating conditions and engine-to-engine variability. Given both the wide array of products on which engines are placed and the variety of environmental issues applicable to operating the equipment, the gas engine will not develop the rated gross power when used in a given piece of power equipment (actual "on-site" or net power). This difference is due to a variety of factors including, but not limited to, accessories (air cleaner, exhaust, charging, cooling, carburetor, fuel pump, etc.), application limitations, ambient operating conditions (temperature, humidity, altitude), and engine-to-engine variability. Due to manufacturing and capacity limitations, Briggs & Stratton may substitute an engine of higher rated power for this Series engine.*

ENGINE

13 HP* Intek OHV — Briggs & Stratton

Horsepower	13 HP @ 3400 rpm
Displacement	21 Cu. In. (344 cc)
Electrical	12 Volt, 3 Amp D.C. Battery 230 CCA
Air Cleaner	Pre-Cleaned Air to Paper Filter
Oil Capacity	3 Pints (1.42 L)

16 HP* Command™ — Kohler

Horsepower	16 HP @ 3400 rpm
Displacement	27.9 Cu. In. (460 cc)
Electrical	12 Volt, 15 Amp Alternator Battery: 230 CCA
Oil Capacity	4 Pints (1.9 L)

TRANSMISSION

Hydro Models

Type	Hydrostatic
Lubrication	Transmission is a Sealed Unit
Ground Speeds	Infinite Forward: 0-5.2 MPH (0-8.4 km/h) Reverse: 0-2.3 MPH (0-3.7 km/h)

CHASSIS

Front Wheels	Tire Size 13 x 5.00-6 Pneumatic Inflation Pressure 10 -12 psi (.68 - .82 bar)
Rear Wheels	Tire Size 16 x 6.50-8 Pneumatic Inflation Pressure 10 -12 psi (.68 - .82 bar)
Fuel Tank	Material: Non-Corrosive Polyethylene Capacity: 2 Gallons (7.5 L)
Turning Radius	Inside Rear Tire 12 In. (30.2 cm)

DIMENSIONS

Overall Length	61 In. (155 cm)
Overall Width	
- w/30 mower	38.5 In. (97.8 cm)
- w/34 mower	45.5 In. (115.6 cm)
- at rear wheels	33 In. (83.8 cm)
Height at	
- steering wheel	41 In. (104.1 cm)
- seat back	35 In. (88.9 cm)
- engine cover	28 In. (71.1 cm)
Wheel Base	43 In. (109.2 cm)
Weight (appx.)	
- 13 HP w/34" mower	Net: 405 lbs (183 kg)
- 16 HP w/34" mower	Net: 405 lbs (183 kg)

Parts & Accessories



REPLACEMENT PARTS

Replacement parts are available from your authorized dealer. Always use genuine Simplicity/Snapper service Parts.

MAINTENANCE ITEMS

Many convenient and helpful service and maintenance items are available from you authorized dealer. Some of these items include:

- | | |
|-------------------|---------------------|
| Engine Oil | Tire Sealant |
| Touch-Up Paint | Degreaser/Degreaser |
| Grease Gun Kit | Gas Stabilizer |
| 8 oz. Grease Tube | |

OPTIONAL ACCESSORIES

- | | |
|------------------------|--------------|
| Twin Bag Grass Catcher | Gas Can |
| Dump Cart | Front Weight |
| Hour Meter Kit | |

TECHNICAL MANUALS

Additional copies of this manual are available, as well as fully illustrated parts lists. These manuals show all of the product's components in exploded views (3D illustrations which show the relationship of parts and how they go together) as well as part numbers and quantities used. Important assembly notes and and torque values are also included.

Technical manuals can be downloaded from

www.simplicitymfg.com

www.snapper.com

Model: _____

Mfg. No.: _____

Your Name: _____

Address: _____

City, State, Zip: _____

Visa/Mastercard No.: _____

Card Expiration Date: _____



www.simplicitymfg.com



www.snapper.com

Briggs & Stratton Power Products Group, L.L.C.
Copyright © 2008 Briggs & Stratton Corporation
Milwaukee, WI USA. All Rights Reserved
www.BRIGGSandSTRATTON.com



www.MasseyLawn.com

