



OWNER'S INSTALLATION AND OPERATION MANUAL

FLOW CONTROL PACKAGE

FOR PLOW SERIAL NUMBERS AFTER

STD200000, STG20000

MTD200000, MTG20000

HTD200000, HTG20000

HTV200000, HTVG10000

32C100000, 32D10000, 32G10000

26D10000, 26G10000

28V10000, 28VG10000

TABLE OF CONTENTS

	Page
TABLE OF CONTENTS	1
INTRODUCTION	2
SAFETY	3
INSTALLATION	4
Receiver Installation on Plow Power Pack	4
FCC Statement of Conditions	4
Industry Canada Statement	4
Programming Receiver to Learn Transmitter Code (Wireless Control).....	4
Wire Harness Installation, Control Harness (Hard-Wired Control).....	5
Install Control Harness Bracket	5
Install Control Harness.....	5
OPERATION.....	7
Theory of Operation	7
Controller Operation.....	7
Switches and Functions - Straight Blade	7
Switches and Functions - V Plow.....	7
Start / Stop Procedure for Hand Held Controller	8
Power Saving Mode	8
Using the Controller to Aid in Mounting and Removing the Snow Plow.....	8
WIRING SCHEMATIC (STRAIGHT BLADE - DOWN PRESSURE SYSTEM)	9
WIRING SCHEMATIC (STRAIGHT BLADE - GRAVITY DOWN SYSTEM)	10
WIRING SCHEMATIC (V PLOW).....	11
WARRANTY	BACK COVER

INTRODUCTION

This manual was written for the assembly, installation and maintenance of your new Sno-Way plow. Most importantly, this manual provides an operating plan for safe use. Refer to the Table of Contents for an outline of this manual.

Please keep this manual with your machine at all times as reference material and so it can be passed on to the next owner if the machine is sold.

We require that you read and understand the contents of this manual COMPLETELY, especially the chapter on SAFETY, before attempting any procedure contained in this manual.



The Society of Automotive Engineers has adopted this SAFETY ALERT SYMBOL to pinpoint characteristics that, if NOT carefully followed, can create a safety hazard. When you see this symbol in this manual or on the machine itself, BE ALERT!, your personal safety and the safety of others, is involved.

• Defined in the next column, are the SAFETY ALERT messages and how they will appear in this manual.

 WARNING
FAILURE TO HEED CAN RESULT IN SERIOUS INJURY OR DEATH.

 CAUTION
Information, that if not carefully followed, can cause minor injury or damage to equipment!

NOTE: Additional information concerning the equipment or the procedure that may or may not be contained elsewhere in this manual.

BE AWARE! It is illegal to remove, deface or otherwise alter the safety decals mounted on this equipment.

Record the Controller Serial Number And The Receiver Serial Number in the space provided below as a handy record for quick reference. The Controller Serial Number is

located on the bottom side of the controller, the Receiver serial number is located on the upper edge of the receiver. This plate contains information that your Dealer needs to answer questions or to order replacement parts, if needed, for your unit.

NAME PLATE DATA	
CONTROLLER SERIAL NUMBER _____	
RECEIVER SERIAL NUMBER _____	
	(FILL IN)

DEALER	
NAME _____	
ADDRESS _____	
CITY _____ STATE _____ ZIP _____	
PHONE () - _____	
	(FILL IN)

ORIGINAL PURCHASER	
NAME _____	
ADDRESS _____	
CITY _____ STATE _____ ZIP _____	
PHONE () - _____	
	(FILL IN)

We reserve the right to make changes or improve the design or construction of any part(s) without incurring the obligation to install such parts or make any changes on any unit previously delivered.



SAFETY



BEFORE ATTEMPTING ANY PROCEDURE IN THIS BOOK, READ AND UNDERSTAND ALL THE SAFETY INFORMATION CONTAINED IN THIS SECTION. IN ADDITION, ENSURE ALL INDIVIDUALS WORKING WITH YOU ARE ALSO FAMILIAR WITH THESE SAFETY PRECAUTIONS.

For your safety Warning and Information Decals have been placed on this product to remind the operator to take safety precautions. It is important that these decals are in place and are legible before operation begins. New decals can be obtained from Sno-Way or your local dealer.

REMEMBER The careful operator is the best operator. Most accidents are caused by human error. Certain precautions must be observed to prevent the possibility of injury to operator or bystanders and/or damage to equipment.

NEVER operate plow when under the influence of alcohol, drugs or other medications that could hamper your judgement and reactions. An accident may result in serious injury or death to other persons or yourself.

ALWAYS operate vehicle in a well-ventilated area. The carbon monoxide in exhaust gas is highly toxic and can cause serious injury or death.

NEVER allow hands, hair or clothing to get near any moving parts such as fan blades, belts and pulleys. Never wear neckties or loose clothing when working on the vehicle.

NEVER wear wrist watches, rings or other jewelry when working on the vehicle or individual equipment. These things can catch on moving parts or cause an electrical short circuit that could result in serious personal injury.

ALWAYS wear safety goggles when working on the vehicle to protect your eyes from battery acid, gasoline, and dust or dirt from flying off of moving engine parts.

ALWAYS be aware of and avoid contact with hot surfaces such as engine, radiator, and hoses.

ALWAYS wear safety glasses with side shields when striking metal against metal! In addition, it is recommended that a softer (non-chipable) metal material be used to cushion the blow. Failure to heed could result in serious injury to the eye(s) or other parts of the body.

NEVER allow children or unauthorized person to operate this unit.

NEVER exceed 45 m.p.h. when snow plow is attached to vehicle. Braking distances may be reduced and handling characteristics may be impaired at speeds above 45 m.p.h.

ALWAYS lock the vehicle when unattended to prevent unauthorized operation of the plow.

ALWAYS check the job site for terrain hazards, obstructions and people.

NEVER exceed 10 m.p.h. when plowing. Excessive speed may cause serious injury and damage of equipment and property if an unseen obstacle is encountered while plowing.

ALWAYS position blade so it does not block path of headlamps beam. Do not change blade positions while traveling. An incorrect plow position blocking headlamp beam may result in an accident.

ALWAYS check surrounding area for hazardous obstacles before operating this unit.

ALWAYS inspect the unit periodically for defects. Parts that are broken, missing or plainly worn must be replaced immediately. The unit, or any part of it should not be altered without prior written approval of the manufacturer.

ALWAYS insert the cylinder lock when plow is not in use. If the cylinder lock is not installed, the plow blade could inadvertently drop and cause serious injury.

ALWAYS shut off the vehicle engine, place the transmission in Neutral or Park, turn the ignition switch to the "OFF" position, firmly apply the parking brake of the vehicle and turn "OFF" the plow controller before attaching or detaching the blade from the vehicle or when making adjustments to the blade.

ALWAYS inspect lift system bolts and pins whenever attaching or detaching the plow, and before traveling. Worn or damaged components could result in the plow dropping to the pavement while driving, causing an accident.

ALWAYS keep hands and feet clear of blade and A-Frame when attaching or detaching plow.

NEVER place fingers in A-frame or mount lug holes to check alignment when attaching snow plow. Sudden motion of the plow could severely injure a finger.

NEVER stand between the vehicle and blade or directly in front of blade when it is being raised, lowered or angled. Clearance between vehicle and blade decreases as blade is operated and serious injury or death can result from blade striking a body or dropping on hands or feet.

NEVER work on the vehicle without having a fully serviced fire extinguisher available. A 5 lb or larger CO² or dry chemical unit specified for gasoline, chemical or electrical fires, is recommended.

NEVER smoke while working on the vehicle. Gasoline and battery acid vapors are extremely flammable and explosive.

NEVER use your hands to search for hydraulic fluid leaks; escaping fluid under pressure can be invisible and can penetrate the skin and cause a serious injury! If any fluid is injected into the skin, see a doctor at once! Injected fluid **MUST** be surgically removed by a doctor familiar with this type of injury or gangrene may result.

REMEMBER it is the owner's responsibility for communicating information on the safe use and proper maintenance of this machine.

INSTALLATION

Receiver Installation on Plow Power Pack

1. Loosen the four screws holding the pump cover in place and then lift and remove the pump cover.
2. Remove the 1/4" x 6" capscrew and 1/4" nylock nut from the top of the two channels located in front of the power unit reservoir.
3. Slide the receiver box into the two channels with the exposed wires of the receiver box positioned toward the front of the plow.
4. Re-install the 1/4" x 6" capscrew and 1/4" nylock nut previously removed and tighten to 7 to 9 Ft. Lb. torque.
5. Connect the 12 terminal connector on the receiver unit to the 12 terminal connector on the snow plow power pack.



WARNING

The connectors must be plugged in correctly. The connectors are keyed; you must line up the slots with the tabs when plugging in the connectors. Failure to do so WILL CAUSE FAILURE of the receiver. When plugged in correctly, the wire colors on each connector will match.

6. Connect the single black ground wire on the receiver to the 5/16" bolt where the plow ground wire is attached to the power unit.

FCC Statement of Conditions

Compliance Statement (Part 15.19)

This device complies with Part 15 of the FCC Rules and with RSS-210 of Industry Canada.

Operation is subject to the following two conditions:

1. This device may not cause harmful interference, and
2. This device must accept any interference received, including interference that may cause undesired operation.

Warning (Part 15.21)

Changes or modifications not expressly approved by the party responsible for compliance could void the user's authority to operate the equipment.

RF Exposure (OET Bulletin 65)

To comply with FCC RF exposure requirements for mobile transmitting devices, this transmitter should only be used or installed at locations where there is at least 20cm separation distance between the antenna and all persons.

Industry Canada Statement

The term "IC" before the certification/registration number only signifies that the Industry Canada technical specifications were met.

Programming Receiver to Learn Transmitter Code (Wireless Control)

Hard-wired control systems do not require the receiver to "learn" the transmitter code. Owners with hard-wired controls can proceed to the next section.

Every transmitter has its own unique code. In order to operate the plow, the receiver must "learn" the transmitters code. The receiver will only function with a transmitter it has been programmed for. That way several wireless units with different transmitter codes can function in the same area. Each receiver can "learn" one transmitter code.



WARNING

More than one receiver can "learn" the same transmitter code. The transmitter will operate all plows with receivers that have been programmed to "learn" its code.

A receiver must have the old code erased before a new one can be added. The receivers may have "learned" a code at the factory. All new receivers must be erased as noted below before "learning" new codes.

To erase any previously "learned" codes:

1. Place a metal object (screwdriver or pocket knife) across the contacts. The receiver is located under the pump cover. The contacts protrude through the potting near the LED on the same side of the receiver that the wire harness is on.

2. Hold the metal object across the contacts until the LED slowly blinks.

3. Remove the metal object.

Programming a receiver to "learn" a transmitter code:

1. Turn on the transmitter that the receiver is to be programmed to.
2. Place a metal object (screwdriver or pocket knife) across the contacts on the receiver. When the green LED on the receiver glows, remove the metal object.
3. Press any function on the transmitter. Hold the function button until the LED on the receiver turns off.
4. Release the function key on the transmitter. The receiver has now "learned" the transmitter code and will return to normal operation.

If the receiver has already "learned" a code, the LED will blink fast for five seconds after the metal object is removed from the contacts. You must erase the code before adding a new one.

Wire Harness Installation Control Harness (Hard-Wired Control)

NOTE: Wireless control systems do not require the control harness to be installed. Wireless owners may proceed to next section.

Remove the wire harness components from the bag of harness parts included in the control package.

Install Control Harness Bracket

1. Using bracket as a template, mark and drill two 9/32" holes into vehicle bumper or other suitable location for mounting of harness bracket. (See Figure 1-1)

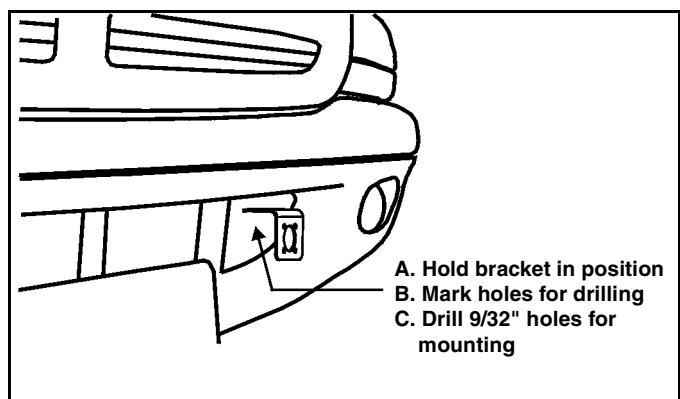

Figure 1-1

2. Install 1/4"-20 bolts up through bracket and vehicle bumper or other mounting surface. Secure with 1/4"-20 nylon locking nuts and tighten. (See Figure 1-2)

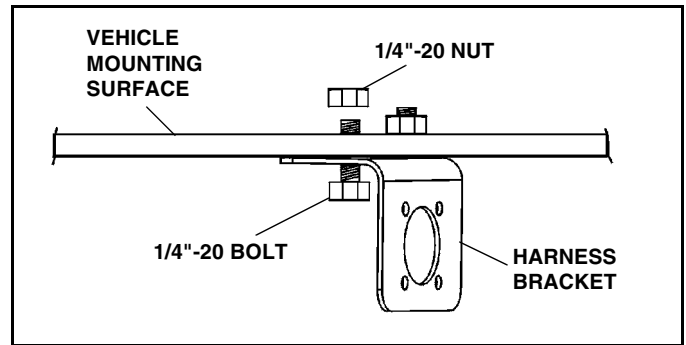

Figure 1-2

3. Install four screws through bracket into harness connector flange and tighten. One of the screws will also fasten the strap for the weatherproof cover. (See Figure 1-3)

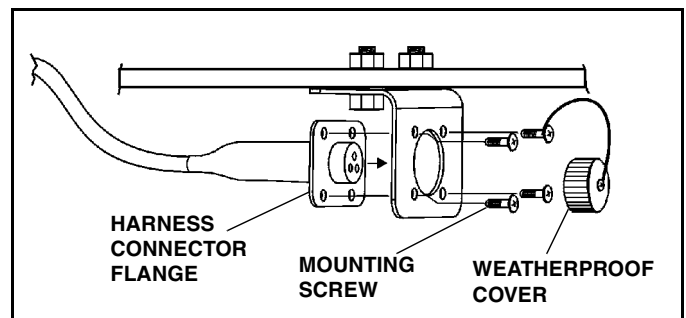

Figure 1-3

4. When operating vehicle without plow attached, install weatherproof cover onto connector to protect electrical contacts. (See Figure 1-4)

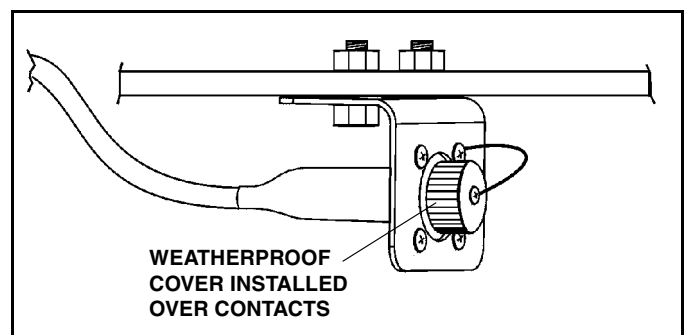



Figure 1-4

Install Control Harness

1. Run the 3 terminal connector on the receiver unit around the reservoir and along the left A-frame angle toward the vehicle.
2. Determine a routing for the 12 ft. long harness from the vehicle bumper at the left side of the power pack through the vehicle engine compartment to the cab of the vehicle.

3. Look for an existing hole, with a rubber grommet, in the vehicle firewall. The hole must be 5/16" diameter or larger.

 **CAUTION**

DO NOT drill any holes until a thorough visual inspection is performed to determine that the area around the hole to be drilled, on both sides of the firewall, is clear of any obstacles such as brake lines, linkage or vehicle wiring.

4. If an existing 5/16" hole is not available, look for an area to drill a 5/16" hole that satisfies these conditions;

• **DO NOT** put a hole in such a spot that will force the wiring harness, when installed, to interfere or be routed behind accelerator pedal, brake pedal, clutch pedal, parking brake or associated linkage.

NOTE: If the hole has to be drilled through carpeting and/or insulation pull carpet and/or insulation back and out of the way. After hole has been drilled, mark back side of carpet and/or insulation where harness will pass through. Mark location to be cut with a "X" then, using a sharp utility knife, cut along the "X". Route harness through drilled hole and cut in carpet and/or insulation. Reinstall carpet and/or insulation. This will allow for a clean repair should the plow ever be removed. Simply place a piece of duct tape on the back side of the carpet and press into place. This will virtually hide the cut in the carpet where the harness was routed.

5. Drill a 5/16" hole through the vehicle firewall.

 **CAUTION**

Keep wiring harness away from moving parts, sharp edges and areas of extreme heat to avoid electrical failure and fire.

6. Insert wiring harness through rubber grommet and firewall, then install grommet into firewall.

7. Insert harness wires through boot and then through strain relief (See Figure 1-5). Push the pins on the end of each of the three wires into the back side of the connector (the end with external threads and numbers 1 thru 4 on the surface). The black wire must be inserted into hole #1 of the connector (note that the holes in the

connector are numbered adjacent to each hole). The white wire must be inserted in hole #2 and the green wire must be inserted in hole #3.

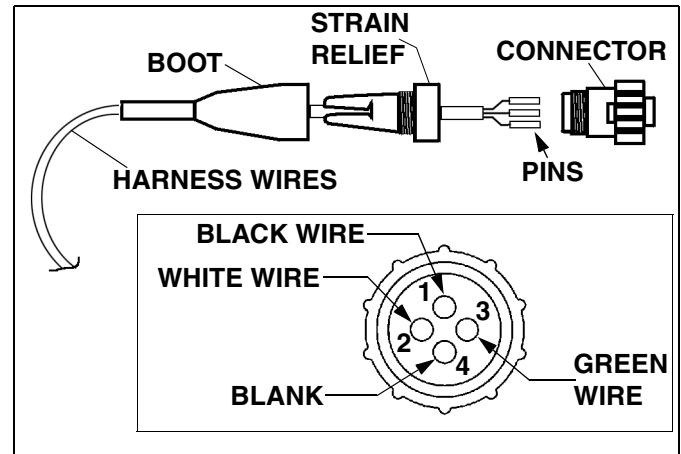

Figure 1-5

 **CAUTION**

The three wires MUST be inserted into the proper holes in the connector. Failure to place the wires in the proper holes in the connector can result in failure of the transmitter.

8. Use a small screwdriver or scribe to push the contacts into the connector until a slight "click" is heard or felt. Visually inspect the connector to make sure the pins are all the way through the housing. Then pull lightly on the wire to make sure the contact is locked into position. If the contact does not come out of the connector, it is properly installed.

NOTE: A contact insertion tool is available from Sno-Way, part number 96105325.

9. After the three wires have been inserted into the connector, screw the strain relief onto the connector and then screw the boot onto the strain relief.

10. After the harnesses have all been properly placed, inspect them to insure that the harnesses are clear of all obstructions and sharp objects and not near any areas of excessive heat. Then, tie the harnesses securely with plastic tie straps (provided) to ensure that the harnesses will stay in place.

11. After all harnesses are in place and all electrical connections have been made. replace the pump cover and tighten the four screws which hold the cover in place.

OPERATION

Theory of Operation

1. The Sno-Way Snow Plow Control System includes a hand held controller. When a switch is actuated, the controller sends a signal out to the snow plow through the plow control harness indicating which operation is to be performed, such as 'Raise', 'Swing Right' and 'DP On'.

2. The second key part of the Control System is the receiver on the plow. It receives the signal from the hand held controller and processes the signal to open or close the proper electrical switches to turn solenoids and valves on or off so that the hydraulic system of the plow power unit will perform the required operations.

3. 12V DC power is fed into the receiver from the battery terminal of the start solenoid. 12V DC power is then fed out of the receiver to the start solenoid primary circuit and to the coils of the valve solenoids. The ground wires for the start solenoid primary circuit and the coils of the valve solenoids return to the circuit board of the receiver where switches on the circuit board open or close the ground to complete or break the circuit to each coil and solenoid.

4. A low voltage power circuit leads from the receiver to the hand held controller. This powers the circuit board of the hand held controller and supplies the low voltage power needed to process the signal from the switches on the hand held unit and send a signal back to the receiver on the plow.

Controller Operation

Functions - Handheld Straight Blade

The hand held controller contains all of the control functions necessary for the operation of your Sno-Way snow plow. The curved rocker switch in the center of the touchpad controls the 'Raise' and 'Lower' functions. Pressing the forward portion of the rocker switch will 'Raise' the plow. Pressing the rearward portion of the rocker switch will 'Lower' the plow. Pressing the raised switch on the right side of the touchpad will swing the blade to the right. Pressing the raised switch on the left side of the touchpad will swing the blade to the left. The round button in the lower center is the 'Down Pressure' switch. Pressing the switch will turn on the down pressure, and a red indicator light in the center of the switch will glow. Pressing the switch again will turn the down pressure off. The round button in the lower right is the 'On-Off' switch. A green indicator light in the center of the switch will glow when the controller is 'On'. The round button in the lower left has no function at this time, and was designed into the controller for possible future use.

Functions - Joystick Straight Blade

The joystick controller contains all of the control functions necessary for the operation of your Sno-Way snowplow. The joystick on the top of the controller controls the 'Raise', 'Lower', and 'Angle' functions. Pulling the joystick toward you will 'Raise' the plow. Pushing the joystick away from you will 'Lower' the plow. Moving the joystick to the right will swing the blade to the right. Moving the joystick to the left will swing the blade to the left. There are two buttons on the front of the controller. The button on the right is the 'Down Pressure' button. Pressing the down pressure button will turn on the down pressure, and a red indicator on the top right corner of the controller will glow. Pressing the button again will turn the down pressure off. The button on the left is the power button. A yellow indicator light on the top left of the controller will glow when the controller is 'On'.

Functions - Handheld V Plow

The hand held controller contains all of the control functions necessary for the operation of your Sno-Way snow plow. The curved rocker switch in the center of the touchpad controls the 'Raise' and 'Lower' functions. Pressing the forward portion of the rocker switch will 'Raise' the plow. Pressing the rearward portion of the rocker switch will 'Lower' the plow. There are four raised switches that surround the 'Raise-Lower' rockers switch. To move the plow so both wings angle right press the two right switches at the same time. To move the plow so both wings angle left, press the two left switches at the same time. To 'Scoop' or 'Vee Forward' press the top two left and right switches at the same time. To 'Vee Backward' press the bottom two left and right switches at the same time. Either wing can be moved independently. To move the right wing forward, press the top right button. To move the right wing backward, press the bottom right button. The left side operation is just the opposite of the right side. The round button in the lower center is the 'Down Pressure' switch. Pressing the switch will turn on the down pressure, and a red indicator light in the center of the switch will glow. Pressing the switch again will turn the down pressure off and return the plow into float mode. The round button in the lower right is the 'On-Off' switch. A green indicator light in the center of the switch will glow when the controller is 'On'. The round button in the lower left has no function at this time, and was designed into the controller for possible future use.

Functions - Joystick V Plow

The joystick controller contains all of the control functions necessary for the operation of your Sno-Way snowplow. The joystick on the top left side of the controller controls the 'Raise' and 'Lower' functions. Pulling the joystick toward you will 'Raise' the plow. Pushing the joystick away from you will 'Lower' the plow. The joystick on the

top right side controls the wings. To move the plow so both wings angle right, move the joystick to the right. To move the plow so both wings angle left, move the joystick to the left. To 'Scoop' or 'Vee Forward', push the joystick away from you. To 'Vee Backward', pull the joystick toward you. Either wing can be moved independently. Pushing the joystick forward and to the left will move the left wing forward. Pulling the joystick back and to the left will move the left wing backward. Pushing the joystick forward and to the right will move the right wing forward. Pulling the joystick back and to the right will move the right wing backward. There are two buttons on the front of the controller. The button on the right is the 'Down Pressure' button. Pressing the down pressure button will turn on the down pressure and a red indicator on the top right of the controller will glow. Pressing the switch again will turn the down pressure off. The button on the left is the power button. A yellow indicator light on the top left of the controller will glow when the controller is 'On'.

Start/Stop Procedure for Controllers

To prevent the controller from inadvertently and accidentally being switched on or off, a sequence is required to turn the controller on or off.

To turn the controller 'On', press the 'On-Off' or 'Power' button and 'Down Pressure' button at the same time. A green or yellow indicator will glow to indicate that the controller is 'On'.

To turn the controller 'Off', press and hold the 'On-Off' or 'Power' button for one second. The controller will turn off and the yellow or green indicator will stop glowing.

Power Saving Mode

The hand held controller uses a very small amount of electrical current anytime it is 'On'. To minimize current use when the controller is inactive, the system has a 'Sleep' mode to shut itself down. If no control function is pressed for a time period of approximately 60 minutes, the controller will shut down by itself. When this happens, the start sequence procedure must be used to re-start the controller.

Using the Controller to Aid in Mounting and Removing the Snow Plow

The hand held controller can be used near the snow plow when mounting or removing the plow with the aid of the power jackstand.

NOTE: For proper procedure in mounting and removal of the snow plow, refer to your Sno-Way plow Owner's Manual.

For Hard-Wired Units

Disconnect the cable for the hand held controller at the harness connection inside the vehicle cab and take the controller to the front of the vehicle. Disconnect the plow control harness from the vehicle control harness at the

connector at the front of the vehicle. Connect the hand held controller harness to the plow control harness. The hand held controller can now be used just as it is normally used in the cab of the vehicle.

For Wireless Units

Remove the hand held controller from the cab, carry it to the front of the truck and use normally.



WARNING

When using the hand held controller near the plow, be especially careful of the movement of any plow components when any switch on the controller is actuated. Stand clear of the snow plow at all times to avoid being struck by any plow parts.

FAILURE TO HEED CAN RESULT IN SERIOUS INJURY OR DEATH.

When plow mounting or removal is completed, disconnect the hand held controller and, if the plow is being mounted, reconnect the harness of the hand held controller to the vehicle harness connector in the cab.

WIRING SCHEMATIC (STRAIGHT BLADE - DOWN PRESSURE SYSTEM)

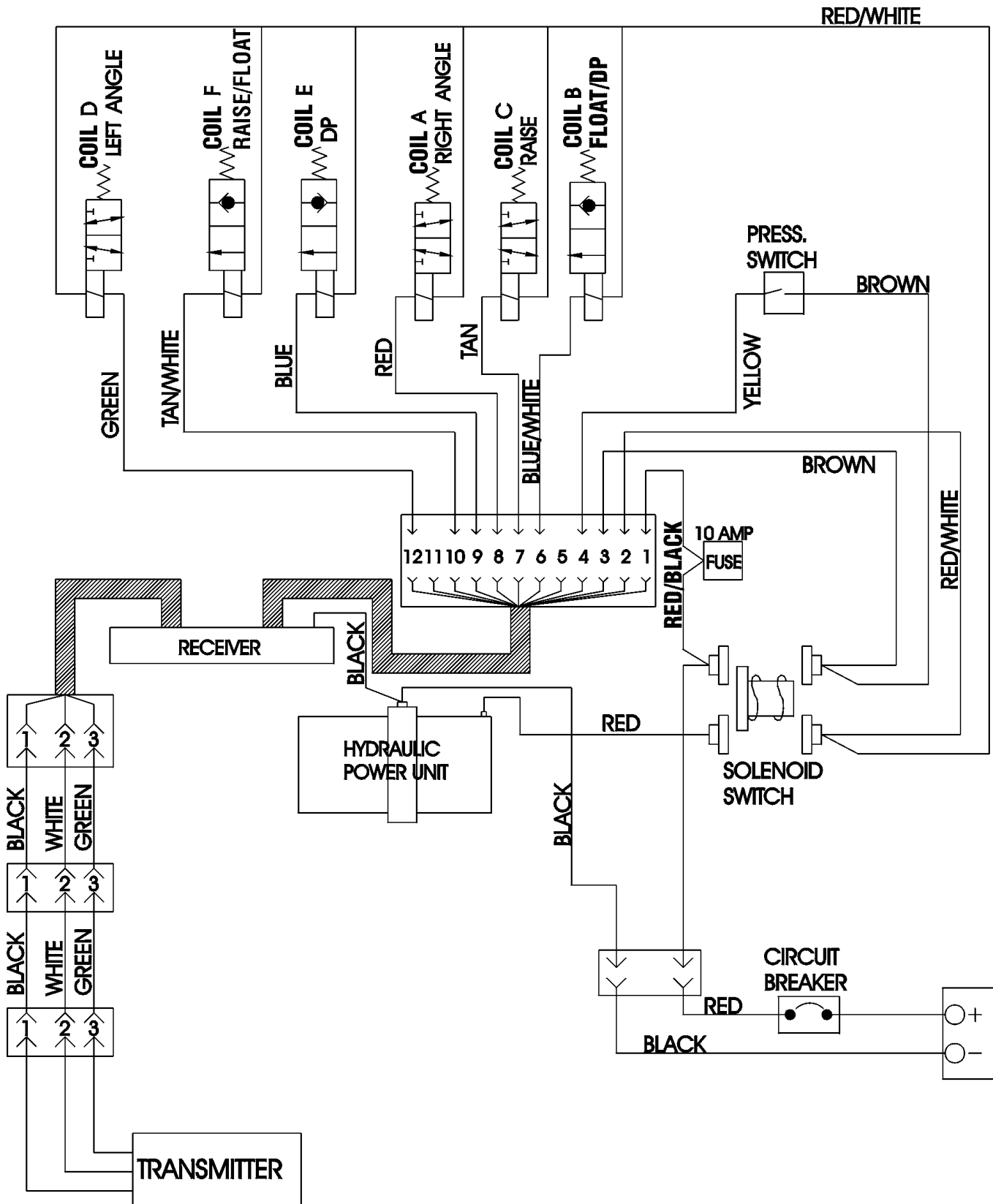

WIRING SCHEMATIC (STRAIGHT BLADE - GRAVITY DOWN SYSTEM)

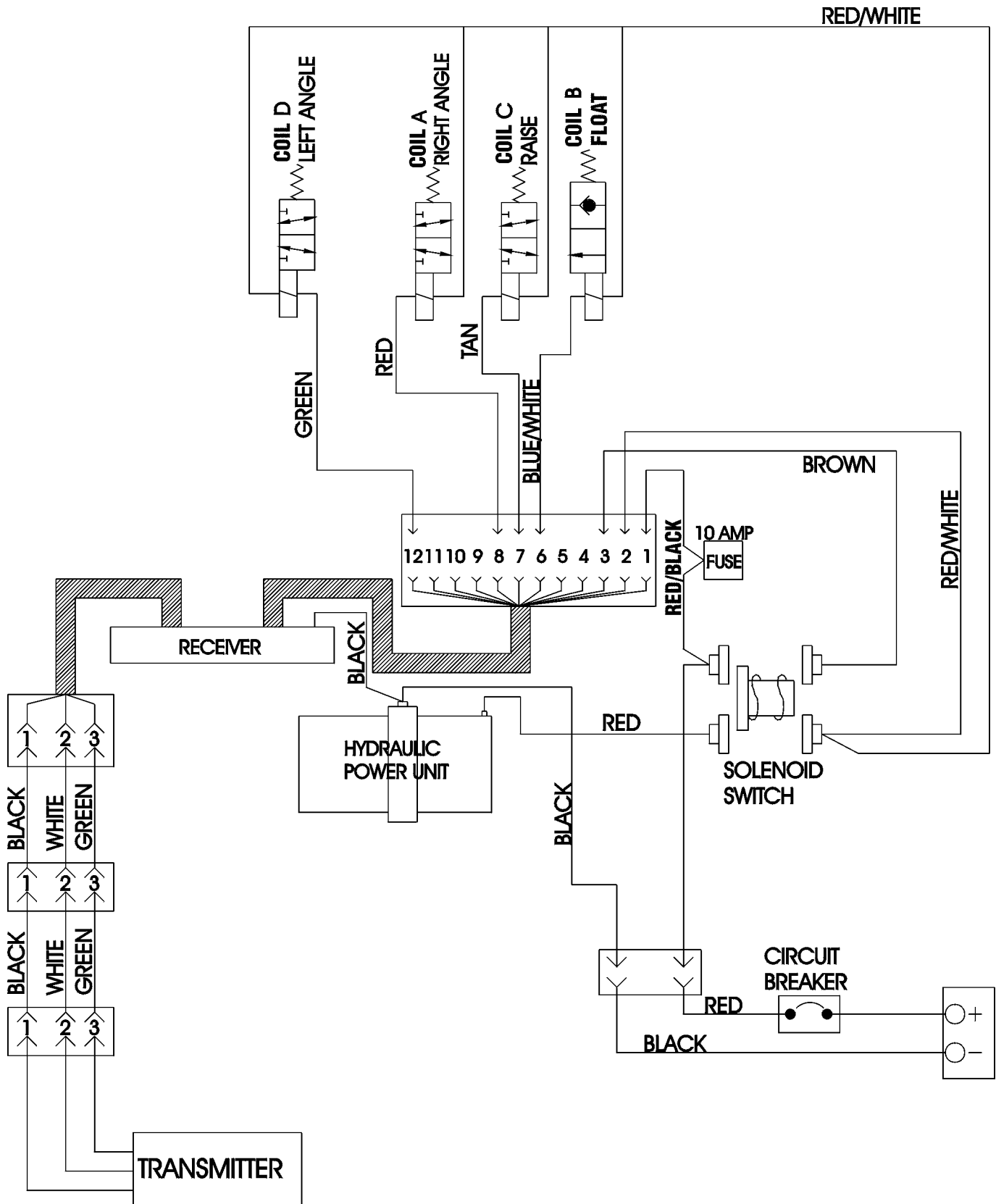

WIRING SCHEMATIC (V FLOW)

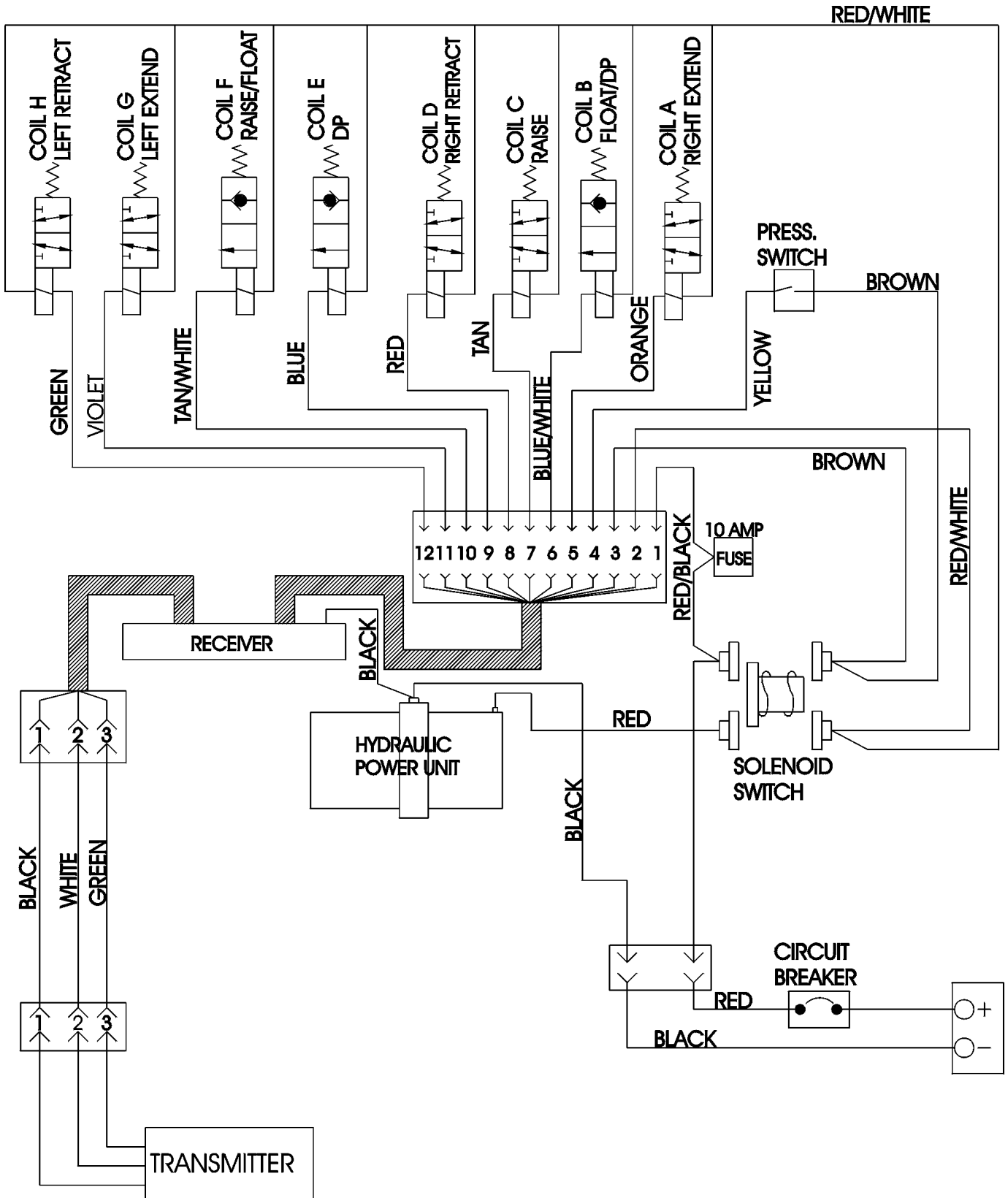

SNO-WAY PLOWS - LIMITED WARRANTY

FIVE YEAR STRUCTURAL LIMITED WARRANTY COVERAGE

The Sno-Way snow plow structural elements are warranted to be free from defects in materials and workmanship for a period of five years from date of delivery from an authorized Sno-Way Dealer. The Sno-Way Warranty Registration card for the product must be properly filled out and mailed to Sno-Way within 30 days of date of purchase to obtain benefits of this section of warranty.

Structural elements are defined for this warranty as: *Blade frames, A-frames, Swing Frames, vehicle sub frames, and structural components (weldments) of Sno-Way snow plows.*

TWO YEAR STANDARD LIMITED WARRANTY COVERAGE

The Sno-Way snow plow nonstructural components are warranted to be free from defects in workmanship for a period of two years from date of delivery from an authorized Sno-Way Dealer. The Sno-Way Warranty Registration card for the product must be properly filled out and mailed to Sno-Way within 30 days of date of purchase to obtain the benefits of this section of warranty.

Nonstructural product components are defined for this warranty as: *Blade inserts (Lexan/Hyzod or steel) and the SM01 Hydraulic power system and control module.*

ONE YEAR STANDARD LIMITED WARRANTY ACCESSORIES / SERVICE PARTS / COMPONENTS.

Sno-Way International, Inc. Warrants accessories, service parts and components purchased separately for a period of one year after original purchase to be free from defects in material and workmanship.

DEFINITION OF PRODUCT:

Product as used throughout this warranty means the Sno-Way line of Predator snow plows, straight blades and "V" blades and components thereof.

EXCLUSIONS UNDER THIS WARRANTY PROGRAM:

1. The installation of product must be an approved installation in accordance with the Sno-Way Vehicle Application Guide, Installation Instructions Manual and the Owner's Manual.
2. The "use" of the Sno-Way product must be in conformity with the operating and maintenance instructions as set forth in the Owner's Manual.
3. Damage as a result of accident, misuse and/or negligence is not covered.
4. The polycarbonate moldboard under the two year warranty does not cover: *Puncture, Hazing, Abrasion, Yellowing, Scratching or Chemical Damage.*
5. Normal wear items are excluded (Without limitation): *Paint finish-corrosion/contamination, Bushings and bearings, Plow shoes, Plow cutting edges, Blade markers/pins/clips, Accessory items and non-standard attachments - or any damage caused by the addition of non-standard attachments not sold by Sno-Way.*
6. Specific exclusions relating to items covered under the Two Year Warranty: *Fasteners and damage caused by failure to retighten fasteners, Electric contact corrosion - damage or abrasion of wiring harness, Control key pads/contacts, Any damage resulting from a failure to properly service and maintain the product as prescribed in the Owner's Manual.*
7. General exclusions:

(A) Any and all damage from the improper installation of product, misapplication of product, abusive use of vehicle and/or product, failure to properly maintain and service, improper repair, service or alteration of product, and any damage as a result of accident or misuse.

(B) Sno-Way will not be liable for any expense not related to defects in materials and workmanship. The attachment of product to or upon a vehicle, including any necessary modification of product or vehicle, is entirely at the purchasers risk and expense, and compliance with applicable motor vehicle rules and regulations is the responsibility of the installer.

(C) This Warranty when applicable applies to the "first" purchaser of product installed in accordance with Sno-Way Application Guides, Installation and Owner's Manuals, and to the transfer of the product by the "first" purchaser to another approved vehicle application by an authorized Sno-Way Dealer.

(D) The "repair" and/or replacement of any part or component is at the option of Sno-Way.

(E) Indirect costs incurred while "product" is being repaired during the warranty period are excluded such as; lost time, equipment rental, transportation charges, and similar incidental charges incurred.

OBTAINING WARRANTY SERVICE

To obtain warranty service, promptly return the product or any defective part at your expense to any authorized Sno-Way Dealer during the warranty period. Replacement or repair of defective or inadequate parts shall be performed without charge for labor or materials by such Dealer at his regular place of business during regular business hours after inspection and determination that the warranty applies.

Purchaser shall prepay all freight charges for returning Product or component to Dealer, Sno-Way or any other location designated by Sno-Way.

Note: The Sno-Way Technical Services help line is designed to service Sno-Way Dealers. Sno-Way Technical and Customer Service will help you locate your nearest Sno-Way Dealer.

Please also use the Sno-Way web site with the Dealer locator: www.snoway.com

DISCLAIMERS:

1. Sno-Way warrants its Products only as set forth in this warranty. Sno-Way makes no other warranties, express or implied, and disclaims all other warranties, including any implied warranty of merchantability or fitness for any particular purpose.
2. Sno-Way's obligations under this warranty are limited to those expressed in this warranty, and Sno-Way shall not be liable to the purchaser or any third party for any direct or indirect, incidental or consequential damage or loss.
3. No person is authorized to modify or add to this warranty in any manner.
4. If any Sno-Way product is improperly installed, altered, misused, damaged or otherwise tampered with, this warranty shall lapse and become null and void.

LEGAL RIGHTS:

Some states do not allow limitations on how long an implied warranty lasts or exclusions or limitations of incidental or consequential damages, so the above limitations or exclusions may not apply fully to you. This warranty gives you specific legal rights, and you may also have other rights which vary from state to state. All "other" provisions and "limitations" not altered by local law shall continue to apply.

ENFORCEMENT/CONSTRUCTION

This Warranty shall be enforced and construed under the laws of the State of Wisconsin.

SNO-WAY INTERNATIONAL, INC.

SNO-WAY® INTERNATIONAL, INC.

The logo for Sno-Way International, Inc. features the word "SNO-WAY" in a large, bold, stylized font. The letters are thick and have a slight 3D effect. A registered trademark symbol (®) is located at the bottom right of the word "WAY".

Hartford, WI 53027 USA
Website: www.snoway.com
©2004 Sno-Way® International