



# **SolarEdge ZigBee Slave Kit Installation Guide**

Version 1.0

# Disclaimers

## Important Notice

---

Copyright © SolarEdge Inc. All rights reserved.

No part of this document may be reproduced, stored in a retrieval system, or transmitted, in any form or by any means, electronic, mechanical, photographic, magnetic, or otherwise, without the prior written permission of SolarEdge Inc.

This document is solely for the use of SolarEdge customers and employees.

The material furnished in this document is believed to be accurate and reliable. However, SolarEdge assumes no responsibility for the use of this material. SolarEdge reserves the right to make changes to the material at any time and without notice. You may refer to the SolarEdge web site ([www.solaredge.com](http://www.solaredge.com)) for the most updated version.

All company and brand products and service names are trademarks or registered trademarks of their respective holders.

Patent marking notice:

<http://www.solaredge.com/groups/patent>

The general terms and conditions of purchase of SolarEdge products shall apply.

The content of these documents is continually reviewed and amended, where necessary. However, discrepancies cannot be excluded. No guarantee is made for the completeness of these documents.



# Table of Contents

<b>Disclaimers</b> .....	<b>2</b>
Important Notice .....	2
<b>Table of Contents</b> .....	<b>5</b>
<b>About This Manual</b> .....	<b>6</b>
<b>Support and Contact Information</b> .....	<b>13</b>
<b>Chapter 1: Introducing the ZigBee Communication</b> .....	<b>15</b>
Overview.....	15
Package Contents .....	15
Installation Procedure .....	15
<b>Chapter 2: Technical information of the SolarEdge ZigBee</b> .	<b>17</b>
General .....	17
Module Features.....	17
SolarEdge Supported Productse .....	18
Mechanical Information .....	18
<b>Chapter 3: Installing the ZigBee Module and Antenna</b> .....	<b>19</b>
Installing the Antenna and Cable .....	19
Mounting the Module in the Inverter.....	23
<b>Appendix A: Configuring ZigBee Communication</b> .....	<b>27</b>
<b>Appendix B: Technical Specifications</b> .....	<b>32</b>
<b>Appendix C: Agency Certifications</b> .....	<b>35</b>

## **About This Manual**

This user manual is intended for Photovoltaic (PV) system owners, installers, technicians, maintainers, and integrators who use the SolarEdge power harvesting system.

This manual describes how to install and set up ZigBee™ communication in a SolarEdge device (inverter or Safety and Monitoring Interface – SMI). The manual instructions and graphics refer to the inverter; however apply to SMI as well.

This guide assumes that the SolarEdge power harvesting system is already installed and commissioned. For additional information about how to install and commission the SolarEdge power harvesting system, refer to the relevant installation guide.

The guide includes the following chapters:

- **Chapter 1: Introducing the ZigBee Communication**, page 11, describes the SolarEdge ZigBee slave module functionality and connection.
- **Chapter 2: Technical information of the SolarEdge ZigBee**
- **General**

The SolarEdge ZigBee Module (SE ZB Module) is a Zigbee Module, enabling Zigbee communication between SolarEdge products – Inverter, Gateway, Home Gateway etc. The Main usage of the SE ZB is to create a ZigBee link between user's products, enabling the user to connect to all ZigBee products via one link, and transfer the data to the Server. By creating a ZigBee link, the user can spare the use of communication cable between his products, enabling easy installation in any place.

## Module Features

---

- Point-to-point connection
- Point-to-Multipoint connection
- Indoor\Outdoor communication
- AT Command control
- No configuration needed

## SolarEdge Supported Productse

---

- SolarEdge Portia (all versions)
- SolarEdge Gateway (all versions)
- SolarEdge Home Gateway (all versions)

## Mechanical Information

---

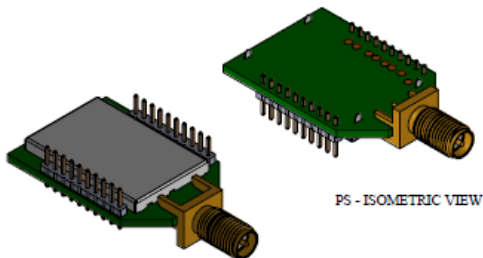



- Size (W) : 26.2 mm
  - Size (L) : 50 mm
  - Size (H) : 10.2 mm
- 
- Chapter 3: Installing the ZigBee Module and Antenna, page 13, describes the module electrical specifications, pinout description, supported devices and mechanical information.
  - **Chapter 2: Technical information of the SolarEdge ZigBee**

## **General**

---

The SolarEdge ZigBee Module (SE ZB Module) is a Zigbee Module, enabling Zigbee communication between SolarEdge products – Inverter, Gateway, Home Gateway etc. The Main usage of the SE ZB is to create a ZigBee link between user's products, enabling the user to connect to all ZigBee products via one link, and transfer the data to the Server. By creating a ZigBee link, the user can spare the use of communication cable between

his products, enabling easy installation in any place.

## **Module Features**

---

- Point-to-point connection
- Point-to-Multipoint connection
- Indoor\Outdoor communication
- AT Command control
- No configuration needed

## **SolarEdge Supported Productse**

---

- SolarEdge Portia (all versions)
- SolarEdge Gateway (all versions)
- SolarEdge Home Gateway (all versions)

## Mechanical Information

---

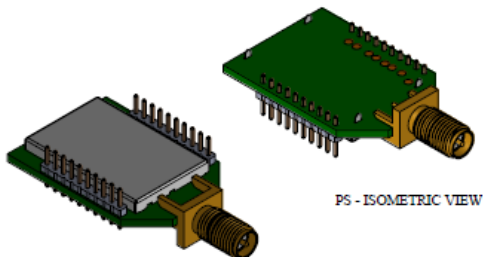

- Size (W) : 26.2 mm
  - Size (L) : 50 mm
  - Size (H) : 10.2 mm
- 
- Chapter 3: Installing the ZigBee Module and Antenna, page 15, describes how to mount, connect and verify the connection of the ZigBee slave module.
  - **Appendix A: Configuring ZigBee Communication**, page 23, describes how to set up the ZigBee communication type in the inverter, if necessary.

- **Appendix B: Technical Specifications** page 28, provides the electrical and mechanical specifications of the SolarEdge ZigBee slave module.
- **Appendix C: Agency Certifications** page 31, Provides all relevant module approvals.

For further information, datasheets and the most up-to-date certifications for various products in different countries, please visit the SolarEdge website: [www.solaredge.com](http://www.solaredge.com)

## Support and Contact Information

If you have technical queries concerning our products, please contact us:

US & Canada	1877 360 5292	<a href="mailto:support@solaredge.us">support@solaredge.us</a>
Germany	+49 89-45459730	<a href="mailto:support@solaredge.de">support@solaredge.de</a>
France	0800917410	<a href="mailto:support@solaredge.fr">support@solaredge.fr</a>
Belgium	080073041	<a href="mailto:support@solaredge.be">support@solaredge.be</a>
Italy	800 784 824	<a href="mailto:support@solaredge.it">support@solaredge.it</a>
Japan	+81.3.5530.9360	<a href="mailto:support@solaredge.jp">support@solaredge.jp</a>
Asia Pacific		<a href="mailto:support_asia@solaredge.com">mailto:support_asia@solaredge.com</a>
Netherlands	08000221089	<a href="mailto:support@solaredge.com">support@solaredge.com</a>
United Kingdom	0800 028 1183	
Greece	00800125574	
Israel	+972 73 240-3118	
Australia	1800 46 55 67	
Worldwide	+972 73 240-3118	
Fax	+972 73 240-3117	

Before contacting SolarEdge, ensure you have the product serial number as appears on its label.

# **Chapter 1: Introducing the ZigBee Communication**

## **Overview**

---

ZigBee is a technology that enables wireless connection between several SolarEdge devices. Up to 32 devices may be inter-connected, in a master-slave configuration. One device is the master (either by having a master ZigBee module pre-installed, or by installing the SolarEdge ZigBee master kit (sold separately). All the other modules act as slaves.

## **Package Contents**

---

- ZigBee slave module
- Antenna
- Mounting clip with RF cable
- This installation guide

## **Installation Procedure**

---

The following illustrates the steps required for the home gateway installation:

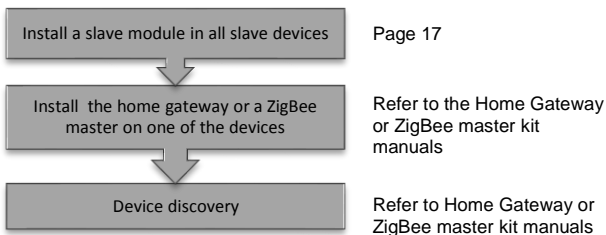



## **Chapter 2: Technical information of the SolarEdge ZigBee**

### **General**

---

The SolarEdge ZigBee Module (SE ZB Module) is a Zigbee Module, enabling Zigbee communication between SolarEdge products – Inverter, Gateway, Home Gateway etc. The Main usage of the SE ZB is to create a ZigBee link between user's products, enabling the user to connect to all ZigBee products via one link, and transfer the data to the Server. By creating a ZigBee link, the user can spare the use of communication cable between his products, enabling easy installation in any place.

### **Module Features**

---

- Point-to-point connection
- Point-to-Multipoint connection
- Indoor\Outdoor communication
- AT Command control
- No configuration needed

## SolarEdge Supported Productse

---

- SolarEdge Portia (all versions)
- SolarEdge Gateway (all versions)
- SolarEdge Home Gateway (all versions)

## Mechanical Information

---

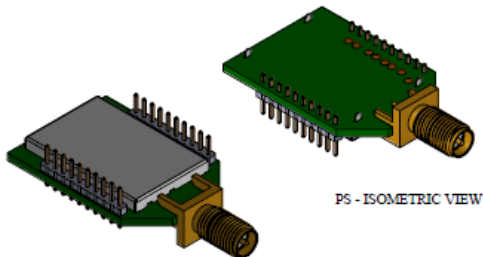

- Size (W) : 26.2 mm
- Size (L) : 50 mm
- Size (H) : 10.2 mm

## Chapter 3: Installing the ZigBee Module and Antenna

Install a slave module in all the devices that will communicate with the master ZigBee device (e.g. home gateway).

### Installing the Antenna and Cable

---

- 1 Connect the antenna to the mounting clip.



Figure 1: Connecting the antenna to the mounting clip

- 2 Attach the mounting clip with the antenna vertically to the top of the inverter. You may attach the clip to the heat sink fins or the inverter side.

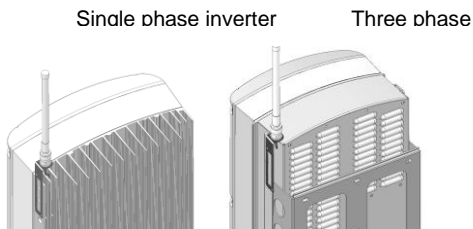

**Figure 2: Antenna mounted on the inverter**

For other SolarEdge devices, or if mounting the antenna not on the inverter top, install the clip on the wall using two screws (not supplied). The antenna must be vertical and far from metal surfaces (including the inverter side).

- 3** Route the antenna cable along the inner fins or the inverter side, in the bracket. Make sure the cable is not hanging loose outside the inverter enclosure.

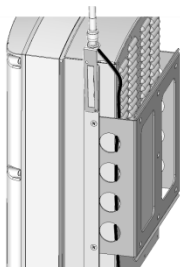

**Figure 3: Routing the antenna cable (Three phase inverter)**

- 4** Disconnect the AC power to the inverter and wait 5 minutes.
- 5** Open the inverter cover as described in its manual.
- 6** Open the gland numbered 1 at the bottom of the SolarEdge inverter.

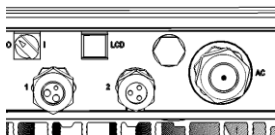

**Figure 4: Inverter sealing glands**

- 7** Remove the rubber seal from the gland and insert the RF cable through the gland cover and the opened connection of the inverter.
- 8** Push the cable into the cut opening of the rubber seal.

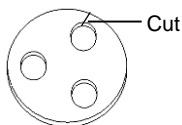

**Figure 5: Rubber seal**

- 9** Insert the rubber seal with the cable into to the gland body and reconnect the gland to the inverter. Tighten the sealing gland.
- 10** Insert the excess of cable length into the inverter until the cable can be tightly attached to the inverter side.

## **Mounting the Module in the Inverter**

---

**1** Connect the ZigBee slave module in its place on the communication board, as shown in Figure 6.

Follow these guidelines:

- Use the marking on the communication board to plug in the ZigBee slave module with the correct orientation
- Insert the ZigBee module such that all pins are correctly positioned in the communication board socket, and no pins are left out of their socket.
- Make sure that the module is firmly in place.

**2** Install the two cable holders on the communication board.

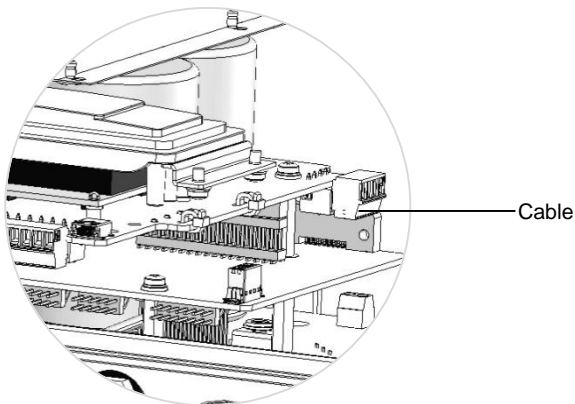

**Figure 6: Cable holders on the communication board**

- 3** Route the cable towards the ZigBee module while snapping it into the two cable holders at the side of the communication board.
- 4** Connect the RF cable to the ZigBee slave module and tighten manually.



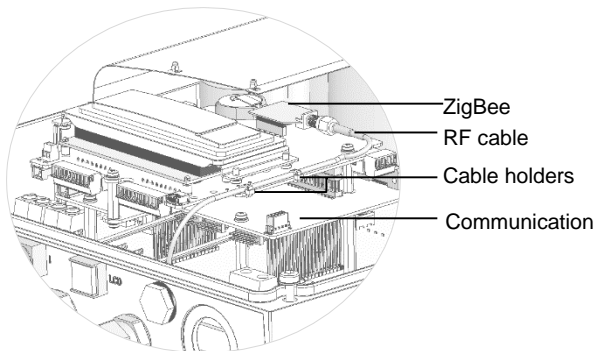

**Figure 7 ZigBee and RF cable on the communication board**

- 5** Close the SolarEdge device cover as described in its manual. Check for proper cover fastening to ensure sealing.
- 6** Turn the SolarEdge device AC power ON.
- 7** The inverter is configured as the slave device by default; therefore, no further configuration is required, unless the default has been changed. In this case, refer to *Appendix A: Configuring ZigBee* on page 27.

**NOTE:**

ZigBee is automatically enabled during the discovery of the inverter by the master. Enabling or configuring ZigBee is not required.

## **Appendix A: Configuring ZigBee Communication**

The inverter is set by default to slave for the ZigBee connection. ZigBee is automatically enabled during the discovery of the inverter by the master. Enabling or configuring ZigBee is not required. Use this procedure only if the default settings have been changed.

The inverter can be configured using the external LCD light button. When using this option, opening the inverter cover is not required in order to set it up.

It is recommended to keep the gateway close to the inverter during configuration.

### **► To configure the Inverter Using the LCD Light Button:**

The following figure illustrates the inverter connector panel:

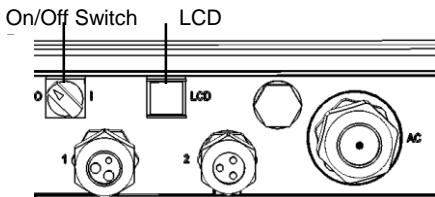

**Figure 8: Inverter connector panel**

Use the LCD button to toggle through the informative status screens, and for communication setup.

- 1** Verify that the inverter ON/OFF switch is OFF.
- 2** Press the LCD Light button once to turn ON the backlight.

If the inverter worked properly before this action, the following message is displayed:

```
D C   V O L T A G E   N O T   S A F E
D O   N O T   D I S C O N N E C T
V D C :           7 2 . 0
```

This message is displayed until the DC is below the safety voltage threshold. The default safety voltage is 50 V.

- 3** Access the Setup mode: Press and hold down the LCD button until the following message is displayed:

```
Keep holding button  
For pairing, release  
To enter menu ...  
Remaining 3 sec
```

Release the button within three seconds to access the Setup Mode. When using setup menus, short press to scroll down to the next menu option and long press to select the item. You can use the Exit option in these menus to move up one menu level.

```
Language  
Communication  
Information  
Maintenance  
Exit
```

- 4** Scroll down to the **Communication** submenu and select it. (Some of the menu items may vary depending on device and configuration).

```
S e r v e r < L A N >
L A N   C o n f
R S 4 8 5 - 1   C o n f < S >
R S 4 8 5 - 2   C o n f < >
Z i g B e e   C o n f < >
R S 2 3 2   C o n f
S l a v e   D e t e c t
```

- 5** Select the **Server** submenu, scroll down to the **Zigbee** option and select it.

```
L A N
R S 2 3 2
R S 4 8 5
Z i g b e e
N o n e
```

- 6** Scroll down to the **ZigBee Conf** submenu and select it.

If **Zigbee Conf <N/A>** indication appears, and ZigBee Conf submenu is not accessible, the ZigBee module is not installed correctly.

```
D e v i c e   T y p e < S E   >
P r o t o c o l < P 2 P >
```

```
D e v i c e   I D < 1 >
P A N   I D
S c a n   C h a n n e l
L o a d   Z B   D e f a u l t s
S l a v e   D e t e c t
```

- 7** Select **Protocol** and set it to **Multi-Point Slave (MPS)**.
- 8** Select **Load ZB Defaults**. The default settings are applied to the inverter.
- 9** Exit the Setup mode by selecting the Exit option in each submenu screen or wait for the device to automatically exit Setup mode, if no buttons are pressed for more than two minutes.

This concludes the slave configuration using the LCD button.

## Appendix B: Technical Specifications

Electrical			
			Unit
Operating Voltage (Typ)	3.0-3.6		V
Current Consumption (Tx Mode)	180		mA
Current Consumption (Rx Mode)	30		mA
Operating Temperature	-40 to +85		C
Interfaces			
RF connector	RPSMA		
Interface Connector	2X10 Header, 2mm		
Interface Protocol	UART \ SPI		
Performance			
	North America	Worldwide	Unit
Transmit power	21.1	11.8	dBm
Receiver sensitivity	-102		dBm
EIRP with antenna	26.1	16.8	dBm



Outdoor (LOS) range*	250	m
Indoor range*	15	m
Regulatory approvals	FCC (USA) IC (Canada) ETSI (Europe) C-Tick (Australia) Telec (Japan)	

---

\* Approximate values, may differ depending on specific installation conditions

## Pinout Description:

P1		P2	
Pin #	Function	Pin #	Function
1	VCC	11	GPIO1_6
2	UART0_TX	12	GPIO1_2
3	UART0_RX	13	GPIO1_7
4	POWER_EN	14	GPIO1_4
5	RESETn	15	GPIO2_0
6	GPIO0_1	16	GPIO1_3
7	GPIO1_5	17	GPIO0_4
8	DEBUG_DD	18	GPIO0_5
9	DEBUG_DC	19	GPIO0_6
10	GND	20	NC

## **Appendix C: Agency Certifications**

### **Labelling requirement for OEM and small device statement (FCC15.19(3))**

*This device complies with part 15 of the FCC Rules. Operation is subject to the following two conditions: (1) This device may not cause harmful interference, and (2) this device must accept any interference received, including interference that may cause undesired operation*

### **Modular approval labeling(FCC 15.212)**

*When integrating the module into the final product, it must be ensured that the FCC labelling requirements, as specified below, are satisfied.*

*Based on the Public Notice from FCC, the final product must display a label referring to the enclosed module. The label should use wording such as the following:*

*Contains Transmitter Module*

*FCC ID: 2AGPT-SEZB*

*IC: 20916-SEZB*

## **Radio Frequency Interference (RFI) (FCC 15.105)**

**This equipment has been tested and found to comply with the limits for Class B digital devices pursuant to Part 15 of the FCC Rules. These limits are designed to provide reasonable protection against harmful interference in a residential environment.**

This equipment generates, uses, and can radiate radio frequency energy, and if not installed and used in accordance with the instruction manual, may cause harmful interference to radio communications. However, there is no guarantee that interference will not occur in a particular installation. If this equipment does cause harmful interference to radio or television reception, which can be determined by turning the equipment off and on, the user is encouraged to try and correct the interference by one or more of the following measures:

- Reorient or relocate the receiving antenna.
- Increase the separation between the equipment and the receiver.

- Connect the equipment into an outlet on a circuit different from that to which the receiver is connected.
- Consult the dealer or an experienced radio/TV technician for help.

### **Modifications (FCC 15.21)**

Changes or modifications to this equipment not expressly approved by SolarEdge Technologies Ltd. may void the user's authority to operate this equipment.

### **RF Exposure info ( FCC 2.1093)**

This equipment has been approved for mobile applications where the equipment should be used at distances greater than 20cm from the human body (with the Exception of hands, wrists, feet and ankles). Operation at distances less than 20cm is strictly prohibited

### **Canadian Compliance**

**This device complies with Industry Canada license-exempt RSS standard(s). Operation is subject to the**

ZigBee Module User Manual - MAN-01-001xx-1.0

**following two conditions: (1) this device may not cause interference, and (2) this device must accept any interference, including interference that may cause undesired operation of the device.**

*Le présent appareil est conforme aux CNR d'Industrie Canada applicables aux appareils radio exempts de licence. L'exploitation est autorisée aux deux conditions suivantes: (1) l'appareil ne doit pas produire de brouillage, et (2) l'utilisateur de l'appareil doit accepter tout brouillage radioélectrique subi, même si le brouillage est susceptible d'en compromettre le fonctionnement.*

The device meets the exemption from the routine evaluation limits in section 2.5 of RSS 102 and compliance with RSS-102 RF exposure, users can obtain Canadian information on RF exposure and compliance.

*Le dispositif rencontre l'exemption des limites courantes d'évaluation dans la section 2.5 de RSS 102 et la conformité à l'exposition de RSS-102 rf,*

*utilisateurs peut obtenir l'information canadienne sur l'exposition et la conformité de rf.*

This transmitter must not be co-located or operating in conjunction with any other antenna or transmitter. This equipment should be installed and operated with a minimum distance of 20 centimeters between the radiator and your body.

*Cet émetteur ne doit pas tre Co-placé ou ne fonctionnant en même temps qu'aucune autre antenne ou émetteur. Cet équipement devrait être installé et actionné avec une distance minimum de 20 centimètres entre le radiateur et votre corps.*

This radio transmitter with model: **SE ZB** has been approved by Industry Canada to operate with the antenna type listed below with the maximum permissible gain and required antenna impedance for each antenna type indicated. Antenna type not included in this list, having a gain greater than the maximum gain indicated for that type, are strictly prohibited for use with this device.

IC ID: 20916-SEZB

ZigBee Module User Manual - MAN-01-001xx-1.0

*Le présent émetteur radio with model: **SE ZB** a été approuvé par Industrie Canada pour fonctionner avec les types d'antenne énumérés ci-dessous et ayant un gain admissible maximal et l'impédance requise pour chaque type d'antenne. Les types d'antenne non inclus dans cette liste, ou dont le gain est supérieur au gain maximal indiqué, sont strictement interdits pour l'exploitation de l'émetteur.*

*IC ID: 20916-SEZB*

Antenna	Manufacturer	Brand	Module Name	Antenna Type	Connector	Gain (dBi)	Frequency Band
xxxx	FT-RF	FT-RF	OI-242505-NM	Omni	SMA	5dBi	2.4-2.5GHz

## **RF Exposure info (IC RSS-102)**

ZigBee Module User Manual - MAN-01-001xx-1.0



The installer of this radio equipment must ensure that the antenna is located or pointed such that it does not emit RF field in excess of Health Canada limits for the general population; consult Safety Code 6, obtainable from Health Canada's website [www.hc-sc.gc.ca/rpb](http://www.hc-sc.gc.ca/rpb) .

***Class B Notice for Canada***

This Class B digital apparatus complies with Canadian ICES-003.

*Cet appareil numérique de la classe B est conforme à la norme NMB-003 du Canada.*

If you have technical queries concerning our products, please contact our support through SolarEdge service portal:  
<http://www.solaredge.com/groups/support/services>

North America	(Toll free) 1877 360 529 2
Australia	(Toll free) 1800 149 229
Germany	089 454 597 30
France	(Toll free) 0800 917 410
Italy	(Toll free) 0800 784 824
United Kingdom	(Toll free) 0800 028 1183
Belgium	(Toll free) 0800 730 41
Israel	073 240 311 8
Rest of world	+ 1 (0) 650 319 884 3
Fax	+ 972 (0) 73 240 311 7
Email to:	<a href="mailto:support@solaredge.com">support@solaredge.com</a>

[www.solaredge.com](http://www.solaredge.com)

**solar**edge



MAN-01-0012B-1.0

ZigBee Module User Manual - MAN-01-001xx-1.0