



CHRYSLER 46RE, 46RH, 47RE, 47RH ZIP KIT®

PART NUMBER 46-47RHE-ZIP

QUICK GUIDE

Parts are labeled here in order of installation. See other side of sheet for details on kit contents.

INSTALLATION DIAGRAM

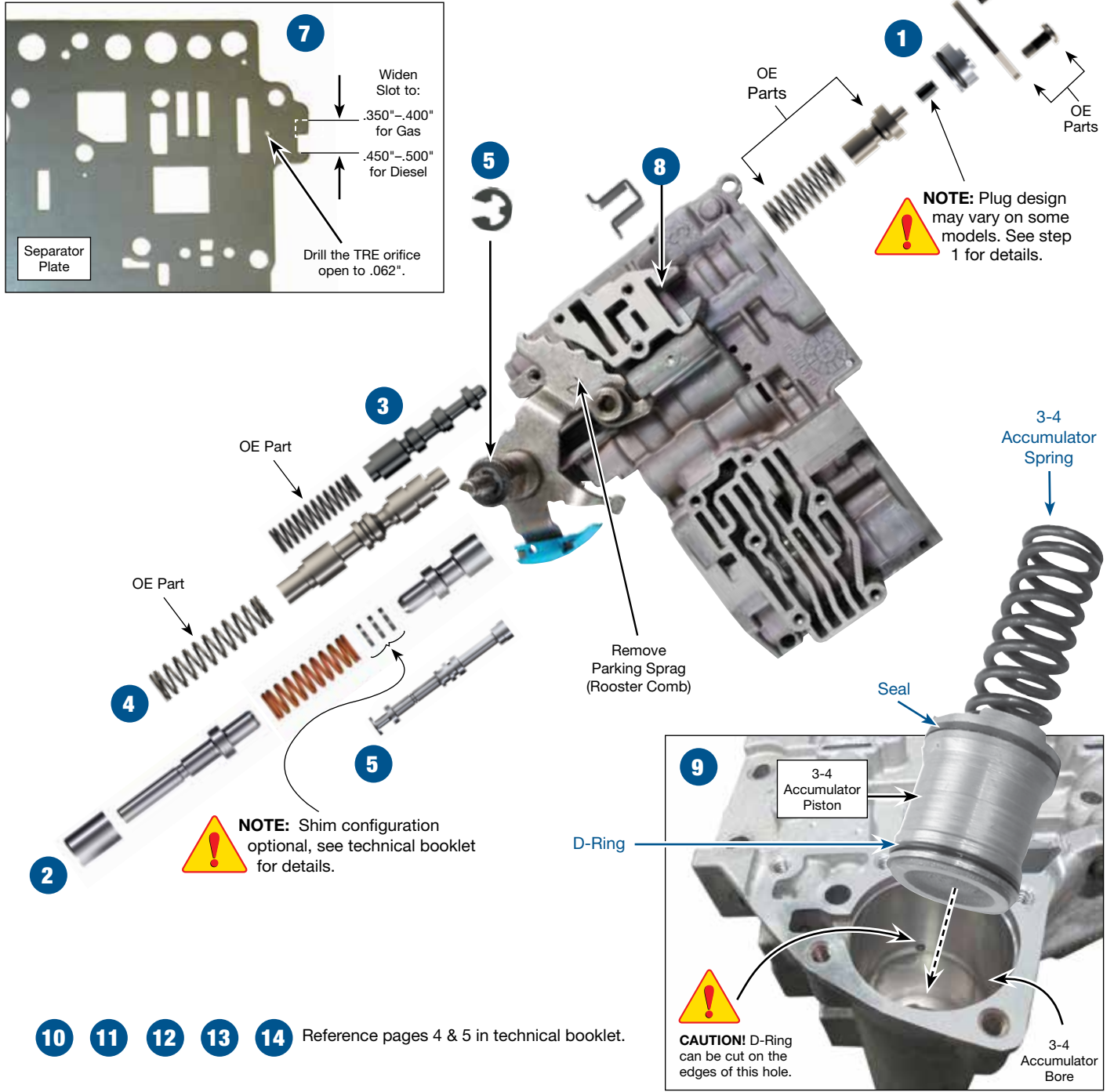
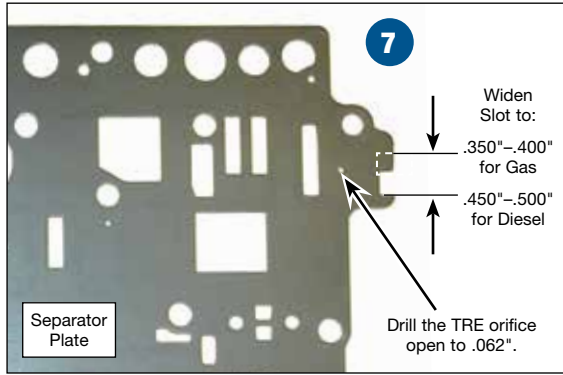

In addition to general rebuilding tips and technical information, the technical booklet included in this kit contains vacuum testing and additional repair options for higher mileage units or for repairing specific complaints which are beyond the scope of this kit.

Kit Contents & Installation Steps

Step 1 Replace Line Pressure Plug & Sleeve

Components provided are designed to replace an OE 3-piece line pressure plug and sleeve arrangement. If an OE 2-piece design is found during disassembly, alternative components (not included) may be required.

Place O-ring into sleeve groove. Lubricate with Sonnax Slippery Stick **O-LUBE** and roll on bench to size. Push Sonnax sleeve into bore, O-ringed end first. Insert plug into sleeve. Reinstall OE end plate, tightening screws to 35 in-lbs.

Packaging Pocket 1

- Plug • Sleeve • O-Rings (2) 1 Extra

Step 2 Remove Parking Sprag & Throttle Pressure Adjusting Screw Bracket & Install Throttle Valve Lineup



NOTE: For helpful hints and details on this step, reference page 2 in technical booklet.

Packaging Pocket 2

- Throttle Valve • Throttle Plunger • Sleeve • Shims (3) • Spring

Step 3 Replace 4-Spooled Switch Valve



NOTE: Part will only fit units with 4-spool switch valve. Reference page 2 of technical booklet for identification.

Packaging Pocket 3

- Switch Valve

Step 4 Replace Pressure Regulator Valve



NOTE: Sonnax pressure regulator valve allows converter charge in Park. **CAUTION:** Verify casting wall at pressure regulator valve has not been drilled with line-to-lube hole. See pages 2 and 3 of technical booklet.

Packaging Pocket 4

Patent No. 6,712,726

- Pressure Regulator Valve

Step 5 Replace Manual Valve, Reinstall Throttle Pressure Adjusting Screw Bracket & Parking Sprag



NOTE: Reference page 3 of technical booklet for helpful hints on OE parking sprag, bracket and spring reinstallation.

Packaging Pocket 5

Patent No. 6,689,007

- Manual Valve • E-Ring

Step 6 Adjust Pressure Regulator Spring & Set Throttle Lever Stop



NOTE: Reference page 3 of technical booklet for details.

Step 7 Separator Plate Modifications

Drill 'TRE' orifice to .062". Using Dremel®, open exhaust port/slot to .350–.400" for gas or .450"–.500" for diesel. The wider the slot, the faster the release oil exhausts and a firmer apply is felt.

Packaging Pocket 6

- Drill Bit, .062" dia. (*not shown*)

Step 8 Replace Boost Valve Retainer

Packaging Pocket 7

- Retainer

Step 9 Replace 3-4 Accumulator Spring & Seals

Remove and discard OE accumulator spring and seals. Install Sonnax scarf-cut seal in groove at open end of OE piston. Install Sonnax D-Ring in groove at closed end of OE piston. Reinstall piston, closed end first into casting bore. Install Sonnax spring and return cover plate and screws, torquing to 35 in-lbs.



CAUTION: D-Ring can be easily cut on sharp casting bore opening.

Packaging Pocket 8

- Spring • Seal • D-Ring

Step 10 Replace Checkballs

Reference page 4 in technical booklet for proper checkball locations.

Packaging Pocket 9

- 3/16" Checkball • 1/4" Checkballs (8) • 11/32" Checkball

Step 11 Replace Intermediate Shaft Pilot & End Plug

Reference pages 4 and 5 in technical booklet for installations tips.

Packaging Pocket 10

- End Plug • Shaft Pilot

Step 12 Install Output Pilot Bushing

Reference pages 4 and 5 in technical booklet for installation tips.

Packaging Pocket 11

- Bushing

Step 13 Install Rear Planet End Play Shim(s)

Reference page 5 in technical booklet for proper installation tips.

Packaged Separately

- Shims (2)

Step 14 Replace Turbine Shaft Seals

Reference page 5 in technical booklet for installation tips.

Packaging Pocket 12

- Seals (2)



CHRYSLER 46RE, 46RH, 47RE, 47RH ZIP KIT®

PART NUMBER 46-47RHE-ZIP

INSTALLATION & TESTING BOOKLET

Unit Assembly Specifications, Apply Chart & Electrical Checks

Electronic Checks		
Solenoid	Terminals	OHM Value
OD Solenoid	6 & 1	20-40
TCC Solenoid	7 & 1	20-40
Governor Solenoid	5 & 1	4-6

Technical Specifications		
Pump-to-Stator Bolts 15 ft-lb	Valve Body-to-Case Bolts 106 in-lb	Pump-to-Case Bolts 15 ft-lb
OE Endplay .034-.084"	Valve Body Assembly Bolts 35 in-lb	

Component Application Chart								
Gear	Front Clutch	Rear Clutch	Front Band	Rear Band	Low Roller Clutch	Overdrive Clutch	Overdrive Direct Clutch	Overdrive Roller Clutch
P								
R	ON			ON			ON	Holding
OD-1st		ON			ON		ON	Holding
OD-2nd		ON	ON				ON	Holding
OD-3rd	ON	ON					ON	Holding
OD-4th	ON	ON				ON		
M2		ON	ON				ON	Holding
M1		ON		ON	ON		ON	Holding

8-Pin Terminal Location & Function	
Pin	Terminal Function
1	12-Volt Power Supply from Relay/TCM
2	5-Volt Power Supply to Governor Pressure Sensor
3	Governor Pressure Sensor Ground
4	Governor Pressure Sensor Signal out to PCM
5	Governor Pressure Solenoid Ground Control from PCM
6	PCM Ground Control to OD Solenoid
7	PCM Ground Control to TCC Solenoid
8	Transmission Oil Temperature Sensor Signal to PCM

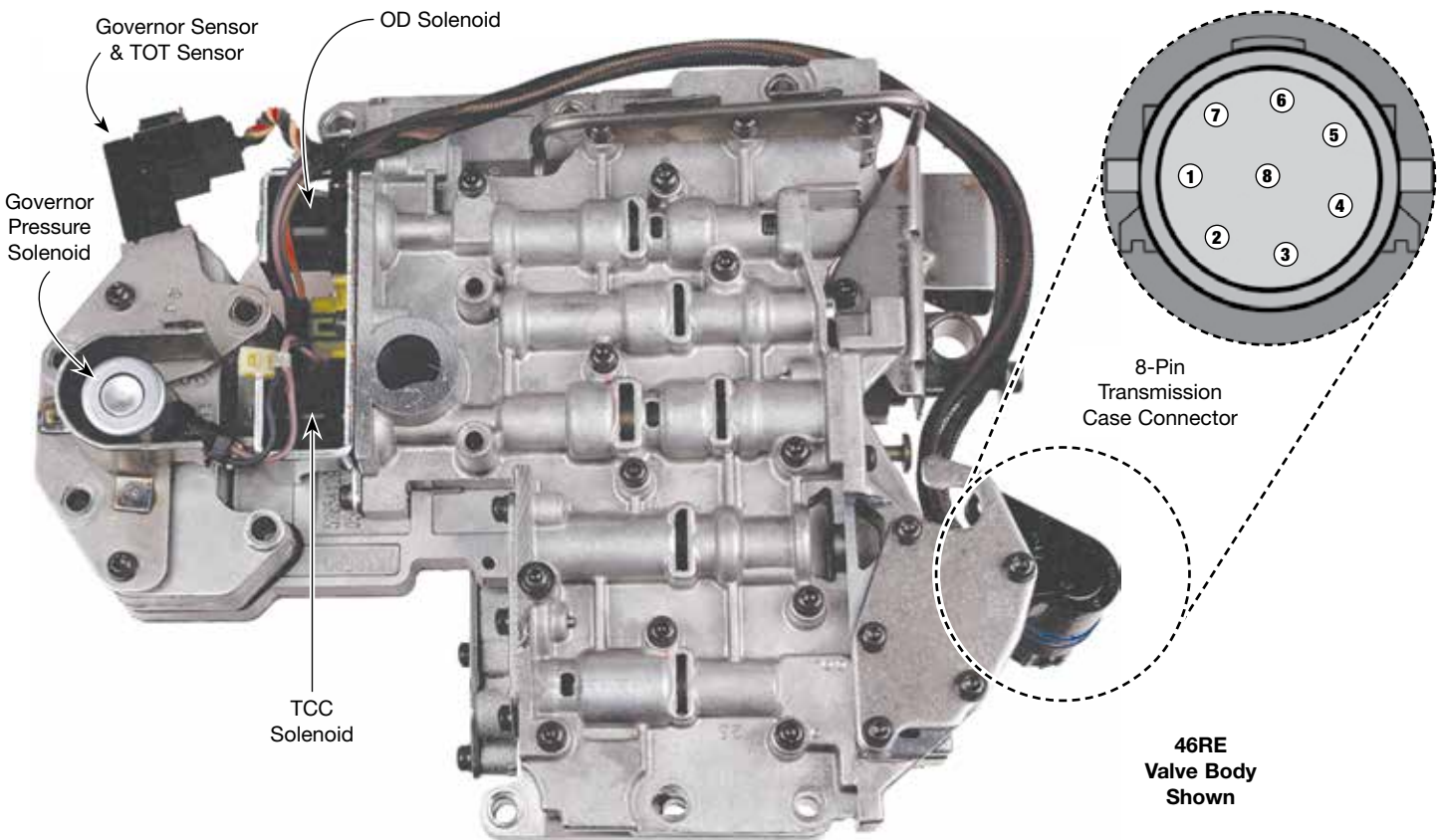

Valve Body & Unit Rebuild Tips & Techniques

Bore-by-bore tips for removal, installation, options and checks of components. The detailed instructions below correlate to the quick guide steps.

1. Replace Line Pressure Plug & Sleeve

Reference quick guide for details.

2. Remove Parking Sprag & Throttle Pressure Adjusting Screw Bracket & Install Throttle Valve Lineup

- a. For ease in removing and installing parking sprag, use small woodworker's type gouge or awl tool to compress detent ball and spring (Figure 1).
- b. Remove and discard OE E-Ring.
- c. Remove parking sprag, detent ball and spring, setting aside for reuse.
- d. Remove throttle pressure adjusting screw bracket and set aside for reuse.



NOTE: A new Sonnax E-Ring is included in this kit for reassembly (see Step 5).

- e. Remove OE throttle valve lineup. Discard sleeve, plunger and spring.
- f. Inspect OE throttle valve for etching between spools, which indicates poor ground circuit. Add additional ground between transmission and chassis ground if necessary. Discard OE throttle valve.
- g. Reference chart to determine shim usage for any desired change in TV pressure.
- h. Install any desired shims over spring stem of Sonnax throttle valve, install in valve body spring stem outboard (Figure 2).
- i. Install Sonnax spring (Figure 2).
- j. Install Sonnax throttle plunger and sleeve (Figure 2).

3. Replace 4-Spooled Switch Valve



NOTE: This Sonnax part (Figure 3) will only fit units with four-spool switch valves. These valve bodies can be easily identified by the tube that supplies oil to the boost valve (Figure 4).

4. Replace Pressure Regulator Valve

- a. Remove OE pressure regulator valve spring and save for reuse.
- b. Remove and discard OE pressure regulator valve.
- c. Install Sonnax lube regulated pressure regulator valve (Figure 5).
- d. Return OE spring to bore, ensuring coils slide over stem of Sonnax valve.



Figure 1

Use gouge tool or awl.

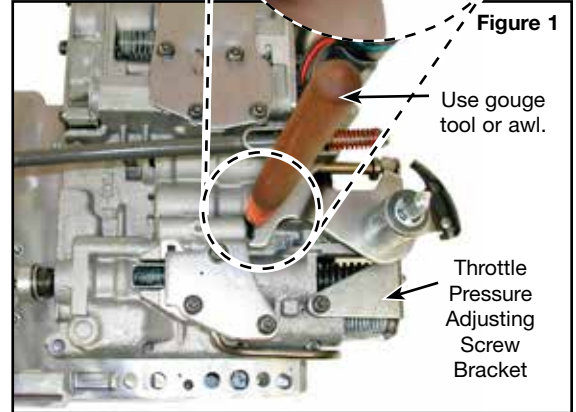

Throttle Pressure Adjusting Screw Bracket

Spring & Shim Usage for Desired Change in TV Pressure

	Spring	No. of Shims	Approx. Change to TV psi
Higher Upshifts	Sonnax	2	+ 14 psi
	Sonnax	1	+ 7 psi
	Sonnax	0	0 psi

OE Specifications	Pressure Regulator Spring
Free Length	2.57"
Wire Diameter	.061"
Approximate No. of Coils	11.5

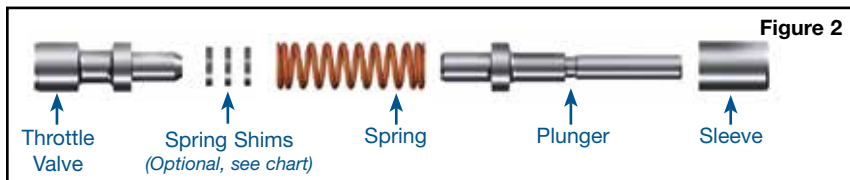

Figure 2

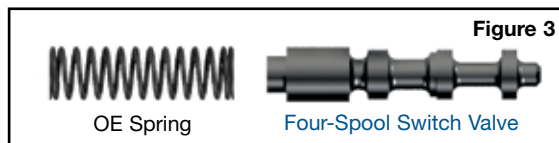

Figure 3

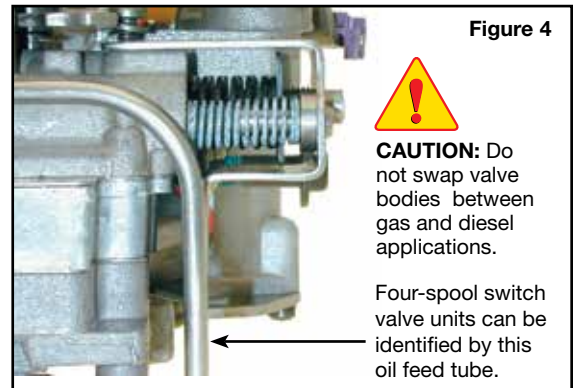

Figure 4



CAUTION: Do not swap valve bodies between gas and diesel applications.

Four-spool switch valve units can be identified by this oil feed tube.

Lube Regulated Pressure Regulator Valve **Figure 5**



Figure 6

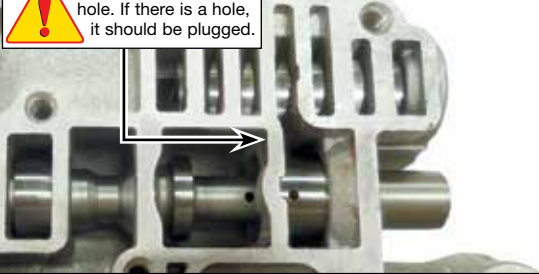

Figure 7

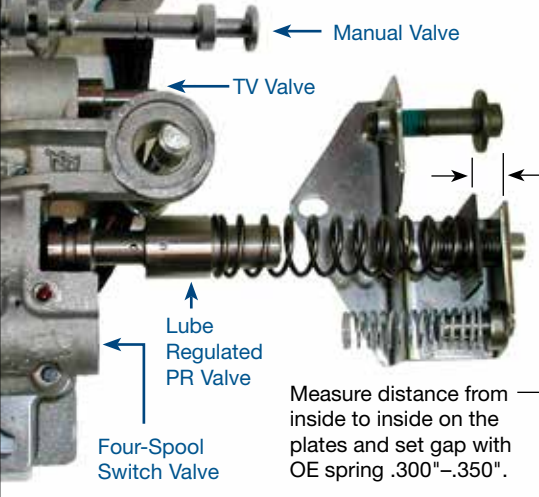
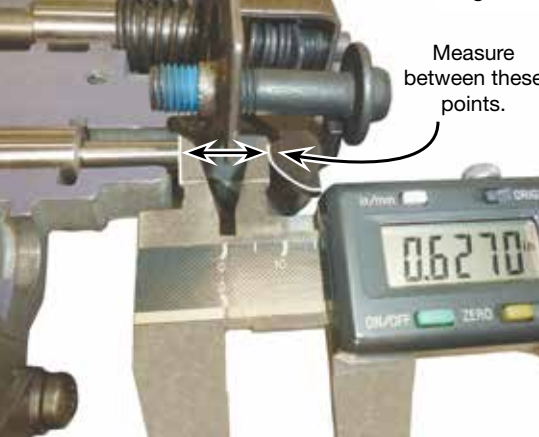

Figure 8



NOTE: Sonnax pressure regulator valve allows converter to be charged in Park.



CAUTION: Do NOT drill line-to-lube hole. If there already is a hole drilled, it should be plugged. A hole here will cause converter drainback (**Figure 6**).

5. Replace Manual Valve, Reinstall Throttle Pressure Adjusting Screw Bracket, Reinstall Parking Sprag

- a. Replace manual valve (**Figure 7**).
- b. Reinstall throttle pressure adjusting screw bracket.
 1. Ensure OE springs are returned to appropriate bores (**Figure 7**).
 2. Torque screws to 35 in-lbs.
- c. Reinstall parking sprag (**Figure 1**)
 1. Reinstall OE spring and detent ball into detent casting bore.
 2. Reinstall OE parking sprag on casting boss. Reference **Figure 1** and use gouge tool or awl for compressing detent ball during assembly.
 3. Install Sonnax E-Ring, ensuring it is installed in proper orientation (**Figure 1**).
 4. Ensure leg on parking sprag engages manual valve.

6. Adjust Pressure Regulator Spring & Set Throttle Lever Stop

- a. Adjust pressure regulator spring.
 1. Line pressure must be between 60–65 psi at idle in drive with minimum TV pressure. This is accomplished by setting distance to .300–.350" between inside of spring retaining plates (**Figure 7**).
 2. Each full clockwise turn of the adjuster will move the plate by approximately .050". Adjust gap between plates to .300–350".



NOTE: This adjustment can only be made with an OE spring. Aftermarket springs will require pressure gauge reading and subsequent readjustment of the distance setting to obtain correct line pressure.

3. Verify line pressure after assembly with a gauge hooked into the line pressure tap located on passenger side, middle of case, between the accumulators. Line pressure will be boosted at TCC apply and 4th gear. Line pressure must be between 60-65 psi at idle in Drive with minimum TV pressure.



CAUTION: Use caution adjusting the spring or high pressure will create bind-ups from cross leaks and increase throttle sensitivity.

- b. Set throttle lever stop.
 1. With throttle valve fully bottomed in bore, measurement between cam and plunger valve must be .627" (**Figure 8**).
 2. Adjust throttle adjusting screw as needed to meet .627" measurement specification.

7. Make Separator Plate Modifications

Reference quick guide for details.

8. Replace Boost Valve Retainer

9. Replace 3-4 Accumulator Spring & Seals

Reference quick guide for details.

10. Replace Checkballs

- a. Install the 3/16" checkball as shown (Figure 9).
- b. On other side of the channel plate, install two 1/4" checkballs as shown (Figure 10).
- c. Install six 1/4" checkballs and one 11/32" checkball in the lower valve body locations (Figure 11).



NOTE: Forward clutch failure will occur if the ball seat for the TV ball in the spacer plate leaks.

Helpful Hint for Valve Body Alignment

It can be helpful to use two 1/8" drill bits, in locations shown, to keep the valve body sections and separator plates in alignment during assembly (Figure 12).

11. Replace Intermediate Shaft Pilot & End Plug (Figure 13)

- a. Using a sheet metal screw, remove the OE cup plug from the OE intermediate shaft (Figure 14) and discard plug.
- b. Using a steel rod (3/16" x 1"), drive the OE shaft pilot out from the cup plug end of the OE intermediate shaft (Figure 15) and discard pilot.
- c. Clean the OE intermediate shaft bore thoroughly.
- d. Install the Sonnax cup plug into place by driving it into the OE intermediate shaft (an AXOD servo pin works well for this).
- e. Install the Sonnax shaft pilot into position by driving it in the front of the intermediate shaft. If the OE intermediate shaft does not have an internal stop to locate the pilot, position it so that .230-.280" of the pilot protrudes from the shaft.

12. Replace Output Pilot Bushing

- a. Drive out OE pilot bushing from overdrive output shaft.
- b. Drive the Sonnax output pilot bushing into the OE overdrive output shaft (Figure 16).

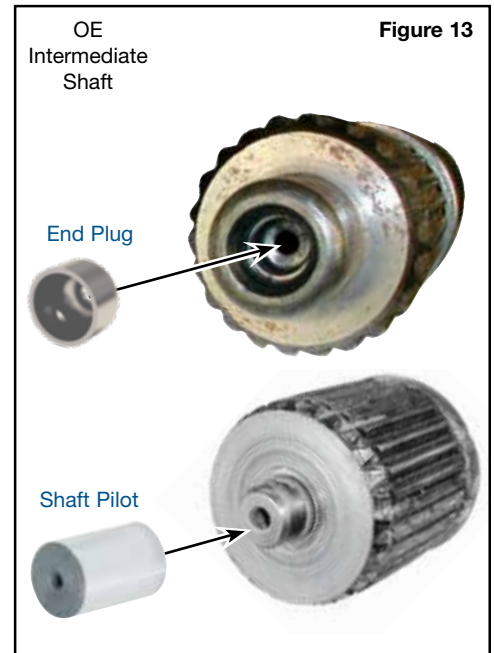
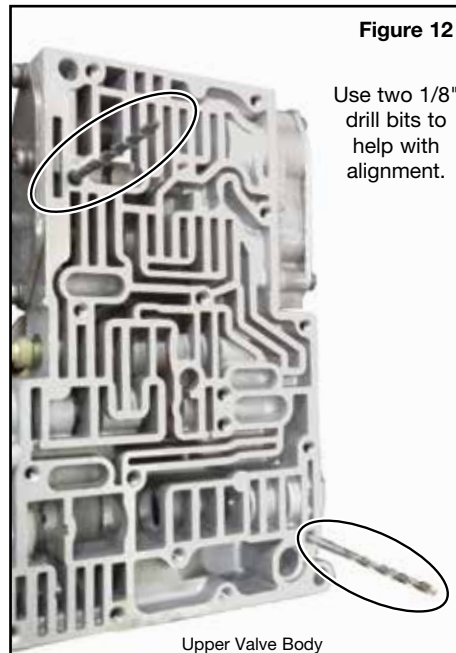
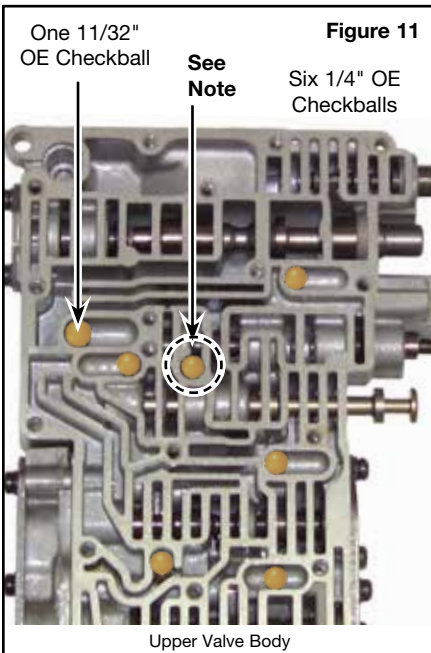
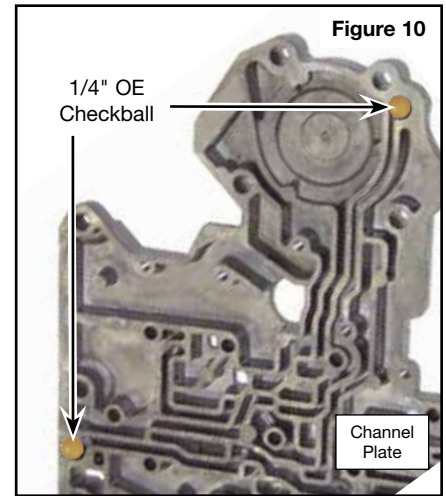
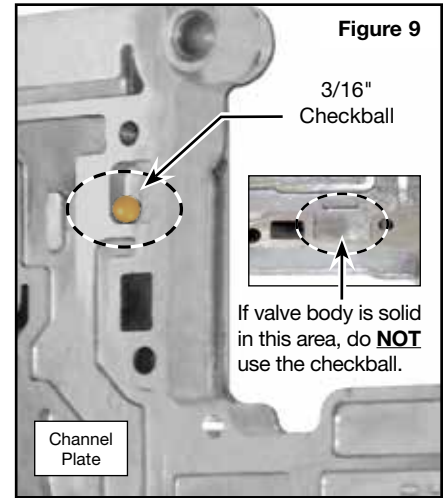

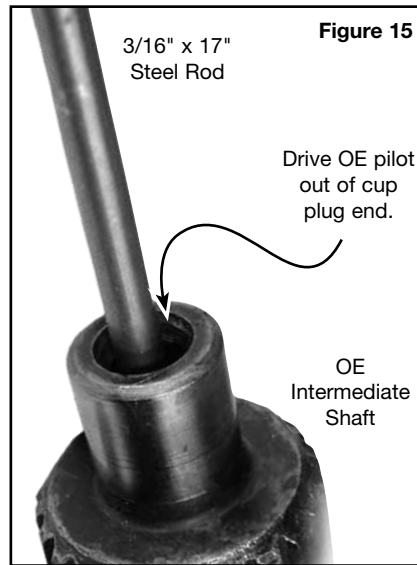
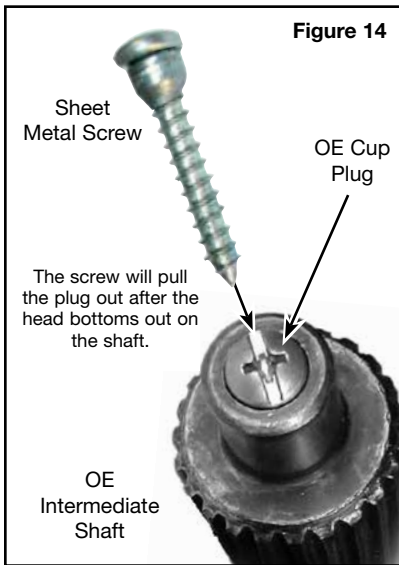

13. Install Rear Planet Endplay Shims (Figure 17)

If inspection of rear annulus gear or intermediate shaft indicates visible wear, the Sonnax endplay shim is generally required to reduce geartrain endplay. To verify:

- Measure the endplay of rear planetary gear, rear annulus gear and driving shell as an assembled unit as illustrated (Figure 18).
- Stand the assembly upright, with the snap ring installed, on a flat surface. Pull upward on the intermediate shaft and measure the clearance.
- Insert a feeler gauge between the rear annulus gear support hub and the intermediate shaft shoulder. The factory specification for the clearance should be between .005" and .048". A minimum of .005" to .010" endplay is preferred. If the clearance exceeds these specifications, Sonnax endplay shim(s) should be inserted between the OE tabbed thrust washer and rear planetary assembly.

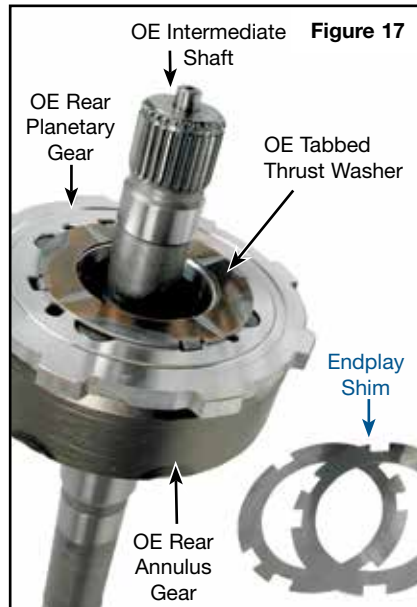
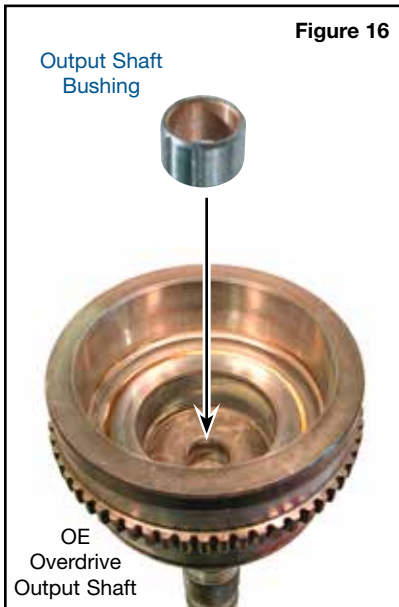

14. Replace Turbine Shaft Seals

- Remove and discard OE shaft seals.
- Install the two PTFE Sonnax turbine shaft seals on the turbine input shaft.

NOTE: Measure sealing ring lands. These seals will NOT work on seal lands measuring 1.170". Only install these seals on landings measuring 1.245" (Figure 19 & 20).

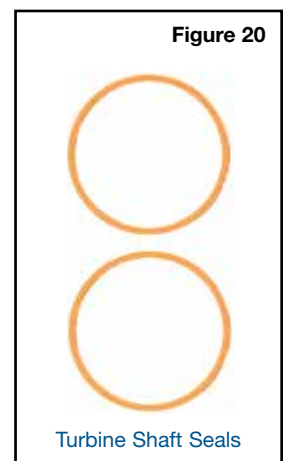
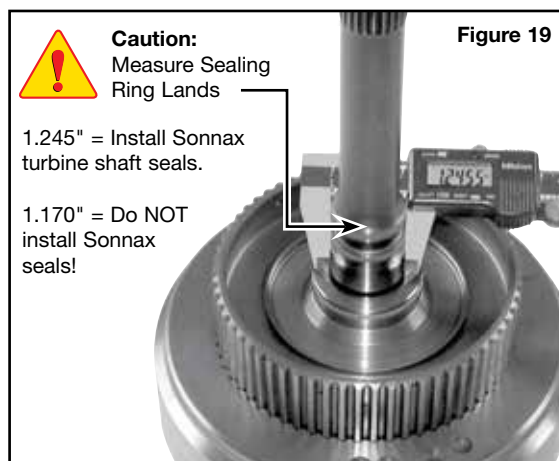
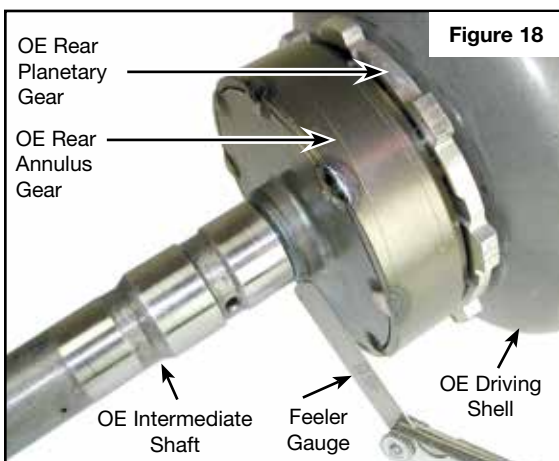

Critical Wear Areas & Vacuum Test Locations



NOTE: OE valves are shown in rest position and should be tested in rest position unless otherwise indicated. Test locations are pointed to with an arrow. Springs are not shown for visual clarity. Low vacuum reading indicates wear and Sonnax parts noted for replacement.

Upper Valve Body • 46RE Shown

4-Spool Switch Valve

- Lockup shudder
- Overheated converter
- Low cooler flow
- Soft TCC apply
- Build up of release pressure during lockup

Replace with Sonnax Part No. 22771A-01*
22771A-13 Requires 22771A-TL13

Pressure Regulator Valve

- Delayed engagement
- Pressure regulator buzz
- Lube failures
- Converter bushing failure

Replace with Sonnax Part No. 22771A-02K* & 22771A-07K
22771A-07K Requires F-22771A-TL7 & VB-FIX

Manual Valve

- Delayed engagement
- No cooler flow in Park
- Converter bushing failure
- Overheated converter
- Forward clutch drags in Park

Replace with Sonnax Part No. 22771-09*

1-2 & 2-3 Governor Plugs

- 1-2 Shuttle
- Early upshifts
- 2-3, 3-2 Oversensitive
- Difficulty in adjusting shift timing with TV linkage

Replace with Sonnax Part No. 22771-14K

Line Pressure Plug & Sleeve

- Reverse slip
- Poor Forward & Reverse engagement
- Poor line pressure control
- Poor cooler charge at idle

Replace with Sonnax Part No. 22229-01K* (.200" Dia.)
22229-04K (.264" Dia.)

Throttle Valve

- Shift timing concerns
- Throttle buzz
- Poor kickdown

Replace with Sonnax Part No. 22771-03K* & 22771-04K
22771-04K *Requires F-22771-TL & VB-FIX

Lockup Boost Valve

- TCC slip under load
- No line rise during TCC apply in 4th
- High line pressure with no indication of boost
- Loss of lube oil
- TCC cycling
- No lockup

Replace with Sonnax Part No. 22771-19K Requires F-22771-TL19 & VB-FIX

Lower Valve Body • 46RE Shown

3-4 Quick Fill Valve

- OD clutch burned
- No 4th
- Gear ratio codes

3-4 Timing Valve

- No 4th
- Gear ratio codes

TCC Apply Valve

- No lockup
- Solenoid codes
- TCC codes

TCC Timing Valve

- TCC failure
- TCC engagement issues
- TCC slip codes

Part numbers with an asterisk () are included in this Zip Kit. Other part numbers are available separately.

OE Exploded View

Upper Valve Body • 46RE Shown

Upper Valve Body Descriptions

I.D. No.	Description
101	2-3 Shift Valve
102	2-3 Throttle Valve Plug
103	Limit Valve
104	1-2 Shift Valve
105	1-2 Shift Control Valve
106	Lockup Boost Valve
107	Throttle Pressure Valve (inboard), Line Pressure Plug & Sleeve (outboard)
108	4-Spool Switch Valve
109	Pressure Regulator Valve
110	Throttle Valve (inboard), Kickdown Valve and Sleeve (outboard)
111	Manual Valve
112	1-2 Governor Plug
113	Shuttle Valve
114	2-3 Governor Plug

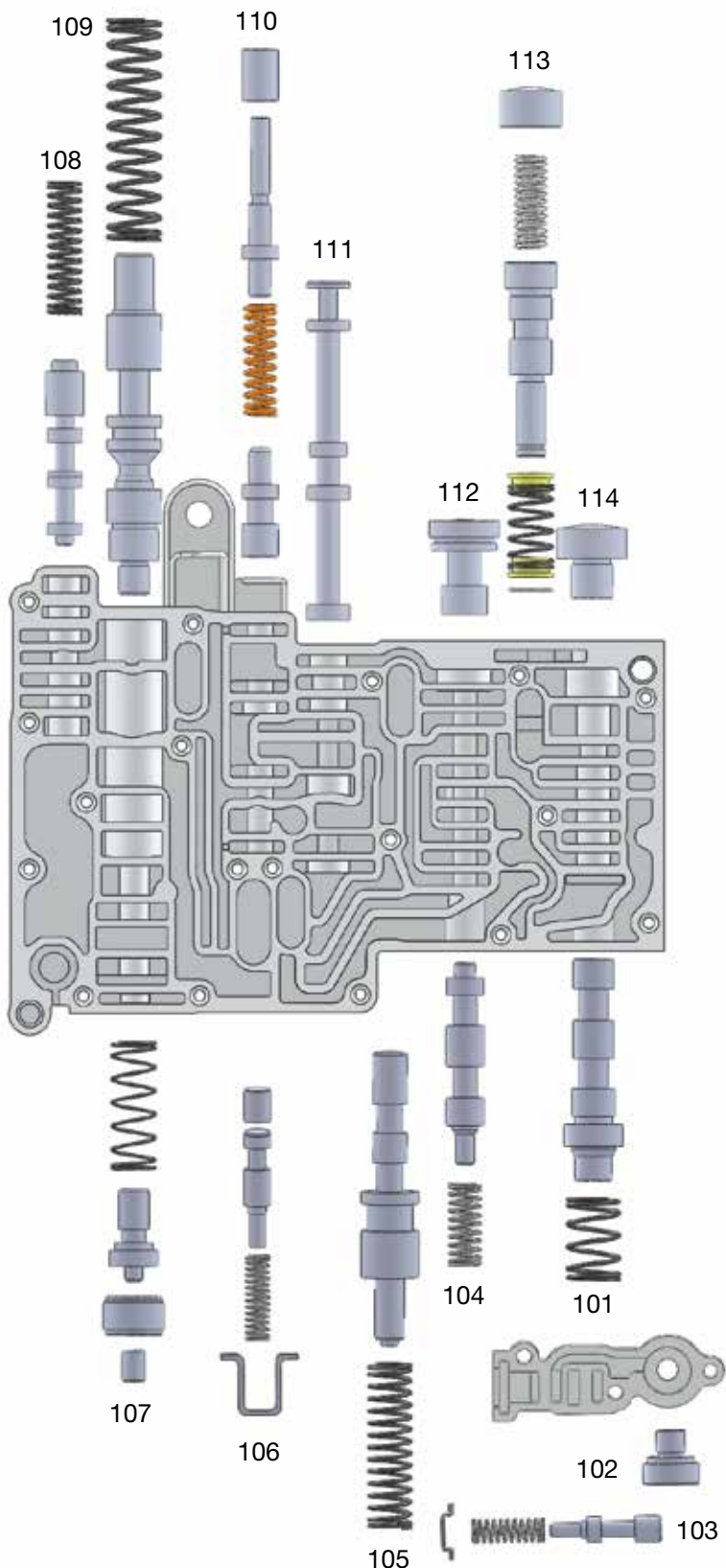

OE Exploded View

Lower Valve Body • 46RE Shown

Lower Valve Body Descriptions

I.D. No.	Description
201	3-4 Quick Fill Valve
202	3-4 Timing Valve
203	3-4 Shift Valve
204	Torque Converter Clutch Apply Valve
205	Torque Converter Clutch Timing Valve

