



FORD 6F35 ZIP KIT®

PART NUMBER 6F35-ZIP

QUICK GUIDE

Parts are labeled here in order of installation. See other side of sheet for details on Zip Kit contents.

INSTALLATION DIAGRAM

Main Control Valve Body



NOTE: The components in this kit are all related to the valve body. It is not necessary to remove pump for kit installation; pump should only be removed if vacuum testing pump locations is desired.

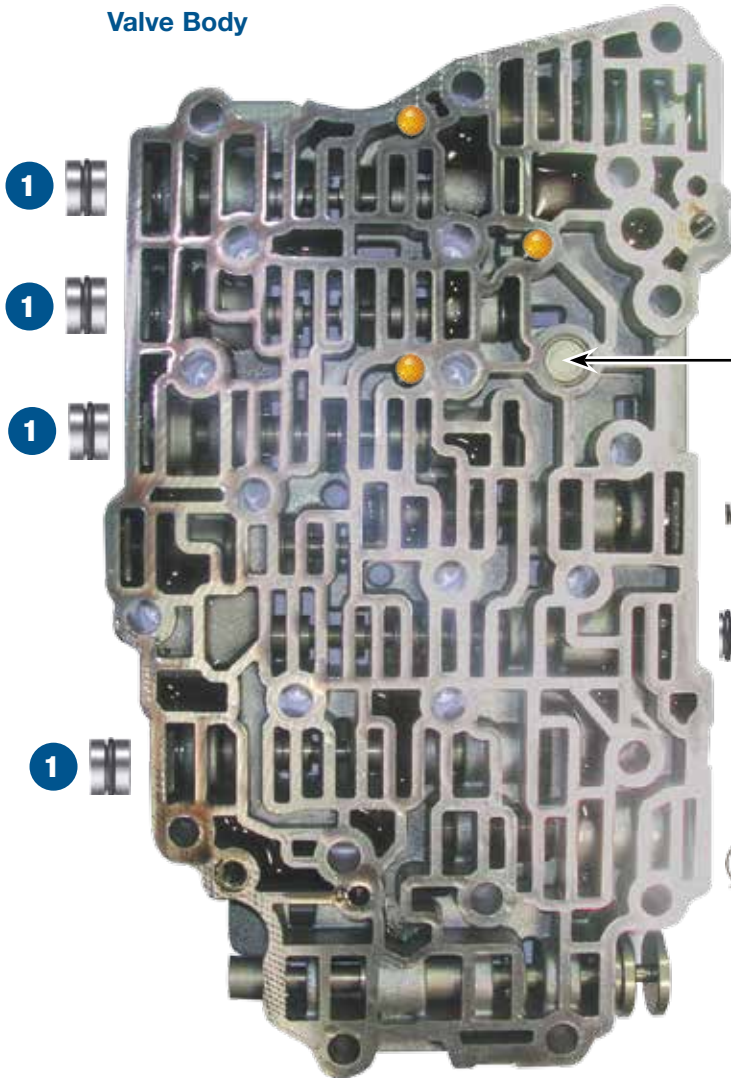

Plastic Checkballs



***NOTE:** These components are protected by U.S. Patent No. 8,794,108.



Solenoid Valve Body

4 Drill balance AFL hole and seal with .062" diameter plug, peening in place.

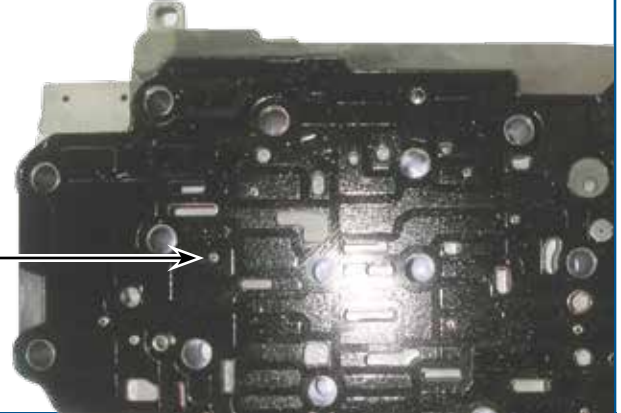

In addition to general rebuilding tips and technical information, the technical booklet included in this kit contains vacuum testing and additional repair options for higher mileage units or for repairing specific complaints which are beyond the scope of this kit.

Zip Kit Contents & Installation Steps

Step 1 Replace 5 OE End Plugs

Place O-ring in groove, lubricate with Sonnax Slippery Stick™ O-LUBE and roll on bench to size.

Note: The end plug at the clutch bypass valve location is slightly different in design and the O-ring should be installed at the inboard land as illustrated.

Packaging Pocket 1

- End Plugs (5)
- O-Rings (7) 2 extra

Step 2 Replace OE Control Pressure Regulator Valve

Packaging Pocket 2

- Valve
- Sleeve
- Spring

Step 3 Replace TCC Regulator Valve Bore Lineup

Remove and discard all OE components except the retainer clip. Keep retainer clip for reuse.



Ensure that the shuttle valve between the inboard regulating valve and end plug is installed with the blind bore facing inboard and the rounded end nub facing the end plug.

Packaging Pocket 3

- Spring
- Valve
- Shuttle Valve
- End Plug
- O-Rings (2) 1 extra

Step 4 Block Solenoid Pressure Regulator Balance Port

Drill indicated separator plate orifice with included .062" dia. drill bit. Remove any burrs. Insert .062" dia. aluminum plug into drilled hole and peen in place on both sides of plate. Ensure plate will still fit flush on both castings.

Packaging Pocket 4

- Drill Bit, .062" dia.
- Aluminum Plug, .062" dia. (2) 1 extra

Step 5 Replace OE Solenoid Pressure Regulator Valve Lineup

Remove and discard OE valve and spring. Keep outboard retainer clip for reuse. Install Sonnax sleeve and valve as illustrated. Secure sleeve in bore by installing included clip into sleeve groove at inboard port. Install included spring and secure all in bore with OE retainer.

Packaging Pocket 5

- Sleeve
- Valve
- Spring
- Retainer Clip

Step 6a Replace OE SSA Damper Piston

Remove and discard OE rubber-tipped damper piston. Install Sonnax spring into Sonnax piston bore pocket. Install Sonnax damper piston, pocket end over spring.

Step 6b Install Checkballs

Packaging Pocket 6

- Piston*
- Spring*
- Checkballs, .250" dia. (3)

*NOTE: These components are protected by Patent No. 8,794,108.



FORD 6F35 ZIP KIT®

PART NUMBER 6F35-ZIP

INSTALLATION & TESTING BOOKLET

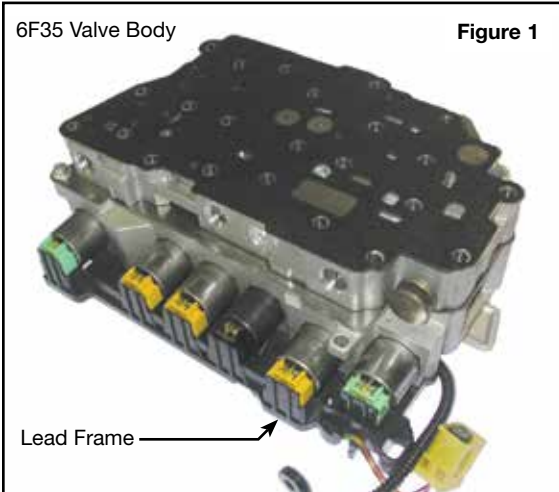

Figure 1

Technical Tips

Reprogramming

Many transmission performance complaints both prior to and after an overhaul can be addressed by reflashing the PCM or TCM. This includes any shift and/or converter clutch scheduling issues, shift bumps, flares, bangs, etc. Refer to OE reflashing procedure for further information.

NOTE: The TCM on the Ford 6F35 is not part of the valve body or transmission, but located in the engine compartment.

Solenoid Body Identification & Strategy

The solenoid body strategy is a file programmed into the PCM to control the various solenoids to prevent shift concerns. The original solenoid body tag on the transmission case indicates the solenoid strategy and solenoid body I.D. (Figure 2). These must match the numbers on the connector boss on the lead frame (Figure 1 & 3).

Anytime a new solenoid body is installed, a new strategy file is downloaded into the PCM with a scan tool. A replacement tag (Figure 4) must be placed on the case as well.

NOTE: The solenoid body strategy is always 13 numeric digits. The solenoid body I.D. is a combination of numeric digits and any letters A-F.

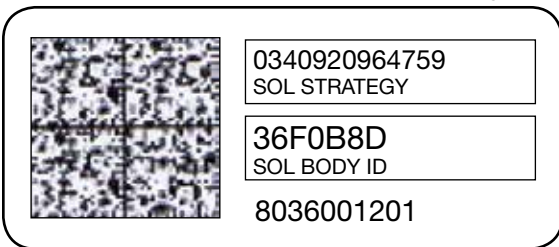

Figure 2

Identification: The original solenoid body tag on transmission case will look like this.



Figure 3

Clutch Apply Chart

Figure 5

Gear	Direct	Overdrive	Forward	Low/Reverse	Intermediate	One-Way
Reverse	X			X		
Drive	1st		X	X*		X
	2nd		X		X	Overrunning
	3rd	X		X		Overrunning
	4th		X	X		Overrunning
	5th	X	X			Overrunning
	6th		X			X

*Turns off above 4mph.

Solenoid Apply Chart

Figure 6

Gear	SSA (VFS) NL	SSB (VFS) NH	SSC (VFS) NL	SSD (VFS) NH	SSE (on/off) NC	TCC (VFS) NL
Park				X	X	
Reverse		X			X	
Neutral				X	X	
Drive	1st	X		X	X	
	2nd	X		X		
	3rd	X	X		X	
	4th	X				X*
	5th		X			X*
	6th			X		X*

KEY: X = On * = Modulating

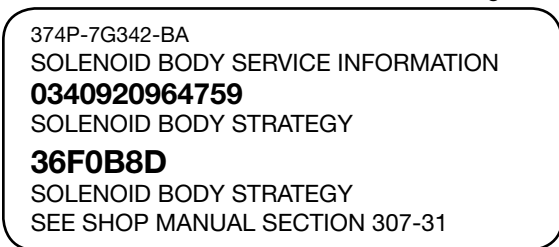
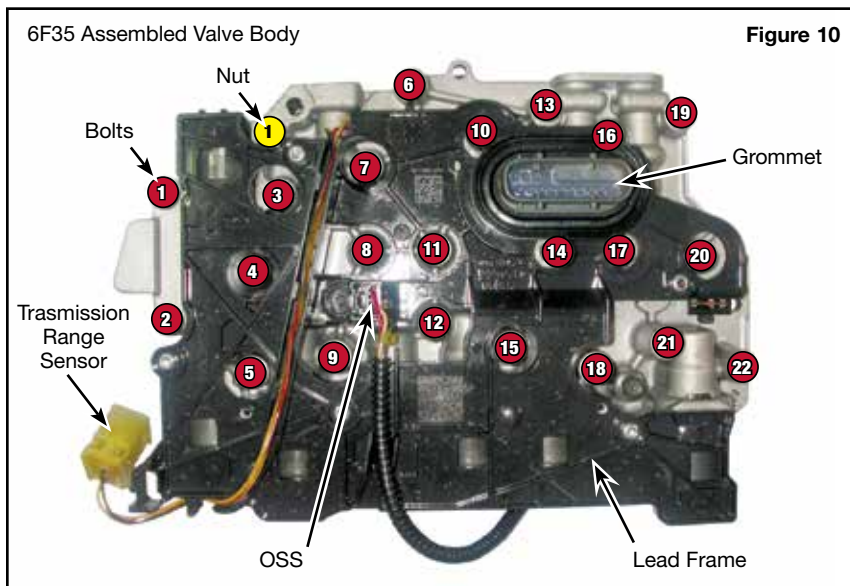
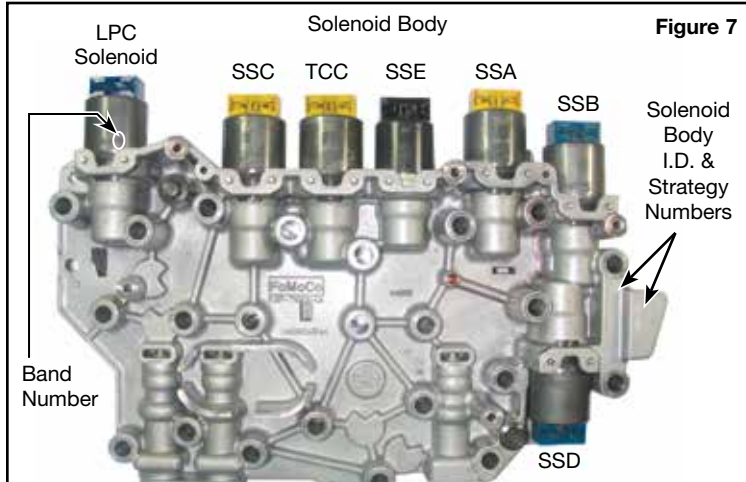

Figure 4

Identification: The replacement solenoid body tag on transmission case will look like this.



Solenoid Body Identification & Strategy (continued)

The solenoid strategy and identification number on the cast aluminum solenoid body (Figures 7 & 8) must also match those on the transmission case tag and lead frame (Figures 2, 3 & 4).

The solenoids are factory calibrated and vary in flow rate. These solenoids can be replaced separately, but only if the replacement solenoid has the same band number as that which it is replacing (Figures 7 & 9). The band number is stamped on the solenoid can, and is the last digit, which is either a 1, 2, 3, 4 or 5.

Zip Kit Instructions

1. Valve Body Removal from Case (Figure 10)

- Disconnect the transmission range sensor.
- Disconnect the output speed sensor (OSS).
- Remove the main control cover grommet.
- Remove the case-to-valve body nut.
- Remove the 22 valve body-to-case bolts.
- Remove the valve body from the transmission.

2. Disassembly

- To remove lead frame from valve body, remove five small screws (Figure 11).



CAUTION: Be careful not to bend or twist the lead frame or solenoid terminals during removal, as damage can occur.

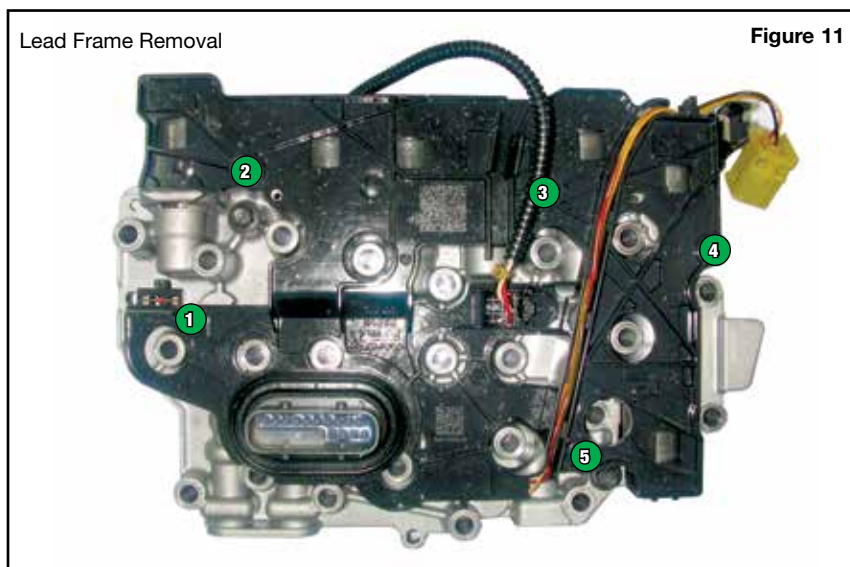

- b. There are 14 solenoid retaining pins (two per solenoid) that keep the solenoids in the casting. Handle the casting with care so these do not fall out and allow solenoids to come out and become mixed up (Figure 12).
- c. To remove solenoid body from valve body, remove two bolts (Figure 12).
- d. To remove separator plate from solenoid body, remove two bolts (Figure 13).

3. Installation

Install Zip Kit parts as shown on diagram of separate quick guide sheet included in this Zip Kit. Sonnax recommends vacuum testing critical wear areas not covered by this kit to determine whether additional Sonnax parts are required (see page 4 & 5).

4. Reassembly



NOTE: OE checkballs often damage the separator plate (Figure 13), preventing proper sealing. Replace the separator plate if necessary, available through Ford (P/N DV6Z-7Z490-B).

- a. Bolt separator plate to solenoid body using two bolts. Torque to 89 in-lb (Figure 14).
- b. Bolt solenoid body to valve body with two bolts. Torque to 89 in-lb (Figure 12).
- c. Attach lead frame to solenoid body assembly using five small screws (Figure 11).

5. Valve Body Reinstall into Case

(Figure 10)

- a. Install the 22 valve body-to-case bolts. Torque to 89 in-lb in the sequence indicated.
- b. Install case-to-valve body nut and tighten to 89 in-lb.
- c. Install the main control cover grommet.
- d. Reconnect the output speed sensor (OSS).
- e. Reconnect the transmission range sensor.

Assembled Valve Body with Lead Frame Removed

Figure 12

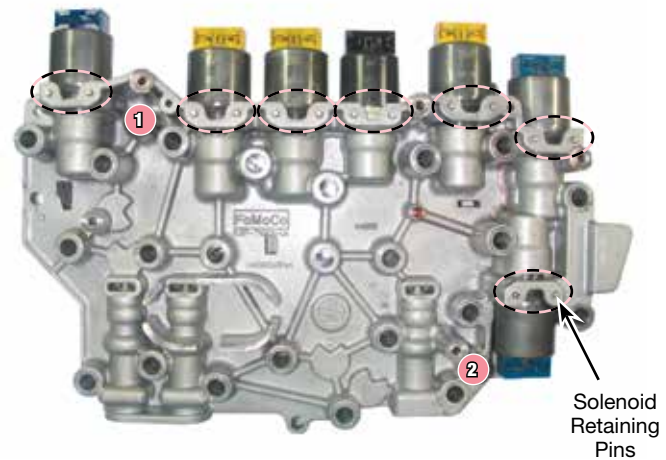

Separator Plate

Figure 13

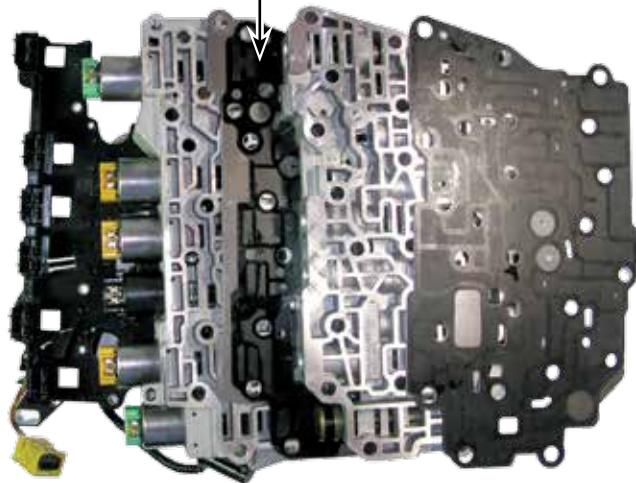

Separator Plate Removal

Figure 14

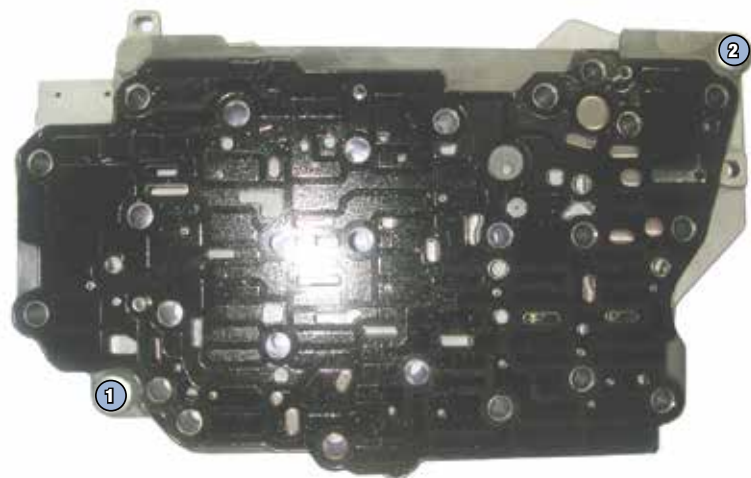

Critical Wear Areas & Vacuum Test Locations

NOTE: OE valves are shown in rest position and should be tested in rest position unless otherwise indicated. Test locations are pointed to with an arrow. Springs are not shown for visual clarity. Low vacuum reading indicates wear and Sonnax parts noted for replacement.

Main Control Valve Body • Front

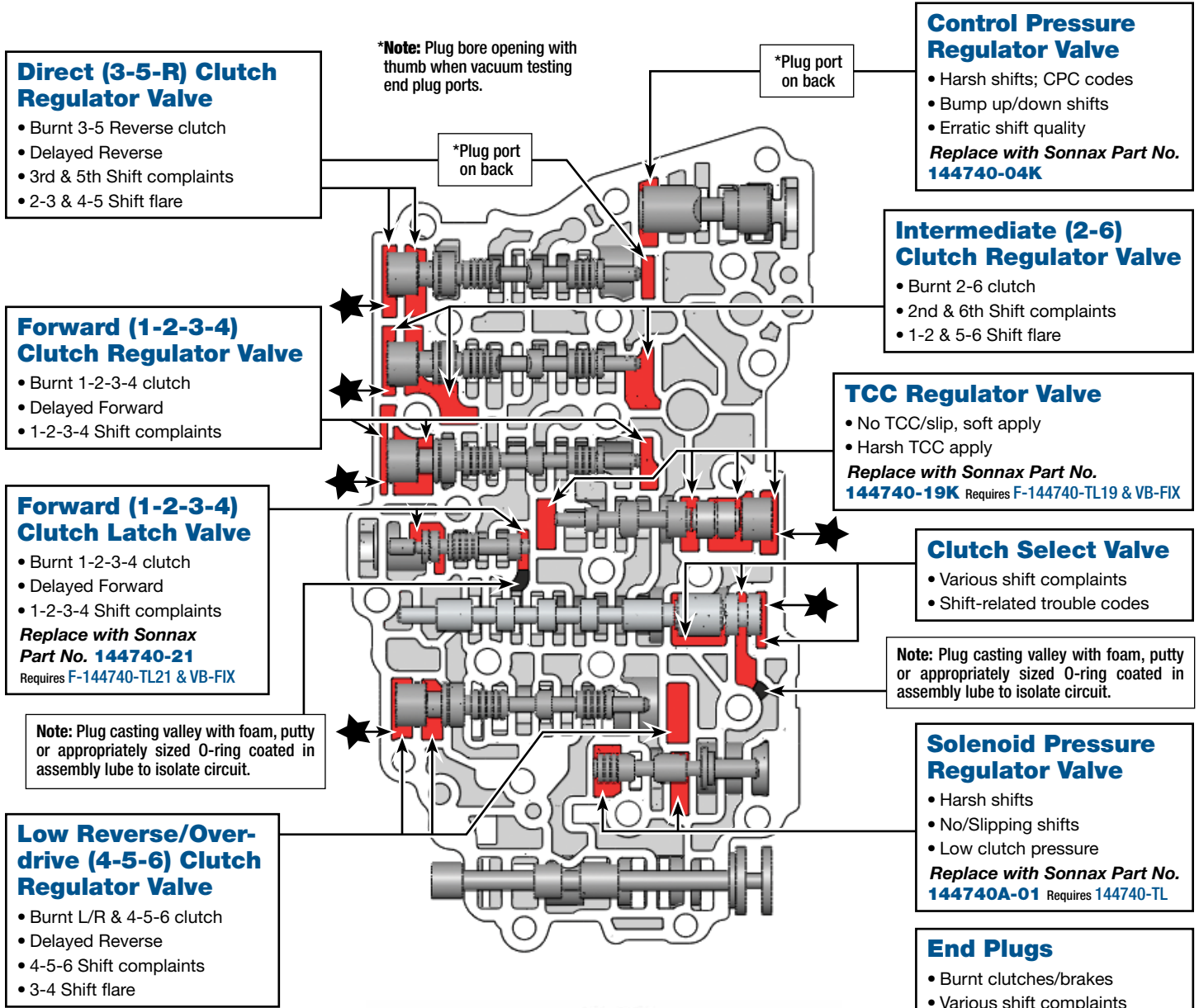

Control Valve Body • Back



Part numbers with an asterisk () are included in this Zip Kit.



For specific vacuum test information, refer to individual part instructions included in kits and available at www.sonnax.com.

Solenoid Valve Body

Low Reverse/Overdrive (4-5-6) Clutch Latch Valve

- Burned L/R & overdrive clutch
- Delayed reverse
- 4-5-6 Shift complaints
- 3-4 Shift flare

Replace with Sonnax Part No. **144740-21** Requires F-144740-TL21 & VB-FIX

Intermediate (2-6) Clutch Latch Valve

- Burned 2-6 clutch
- 2nd & 6th Shift complaints
- 1-2 & 5-6 Shift flare

Replace with Sonnax Part No. **144740-21** Requires F-144740-TL21 & VB-FIX

Direct (3-5-R) Clutch Latch Valve

- Burned direct clutch
- Delayed reverse
- 3rd & 5th Shift complaints
- 2-3 & 4-5 Shift flare

Replace with Sonnax Part No. **144740-21** Requires F-144740-TL21 & VB-FIX

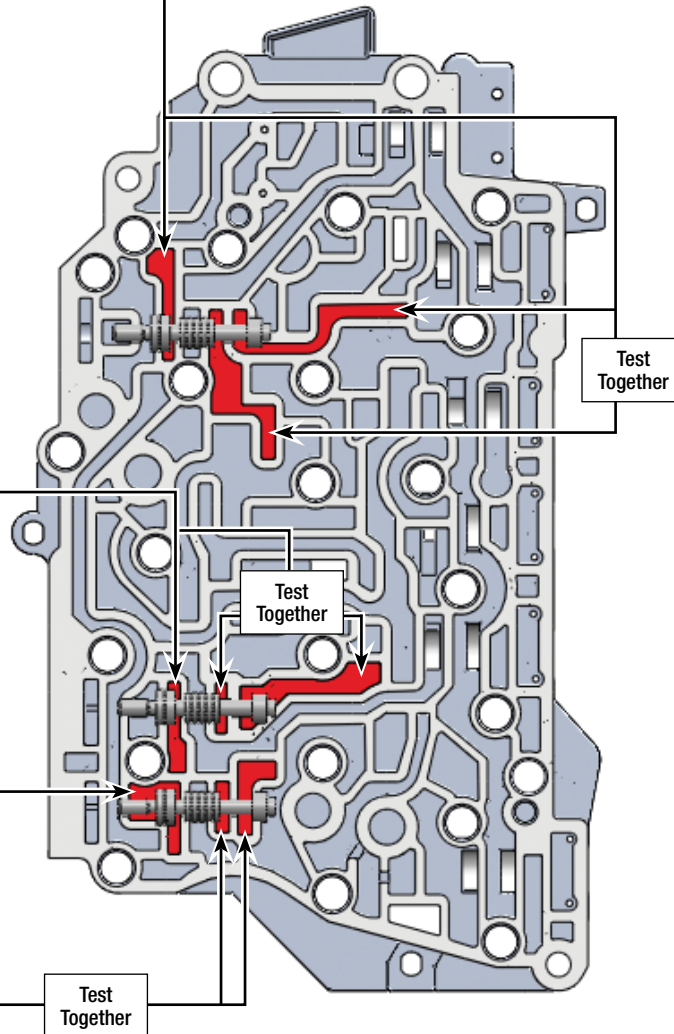

Critical Wear Areas & Vacuum Test Locations



NOTE: OE valves are shown in rest position and should be tested in rest position unless otherwise indicated. Test locations are pointed to with an arrow. Springs are not shown for visual clarity. Low vacuum reading indicates wear and Sonnax parts noted for replacement. For specific vacuum test information, refer to individual part instructions included in kits and available at www.sonnax.com.

Pump Body

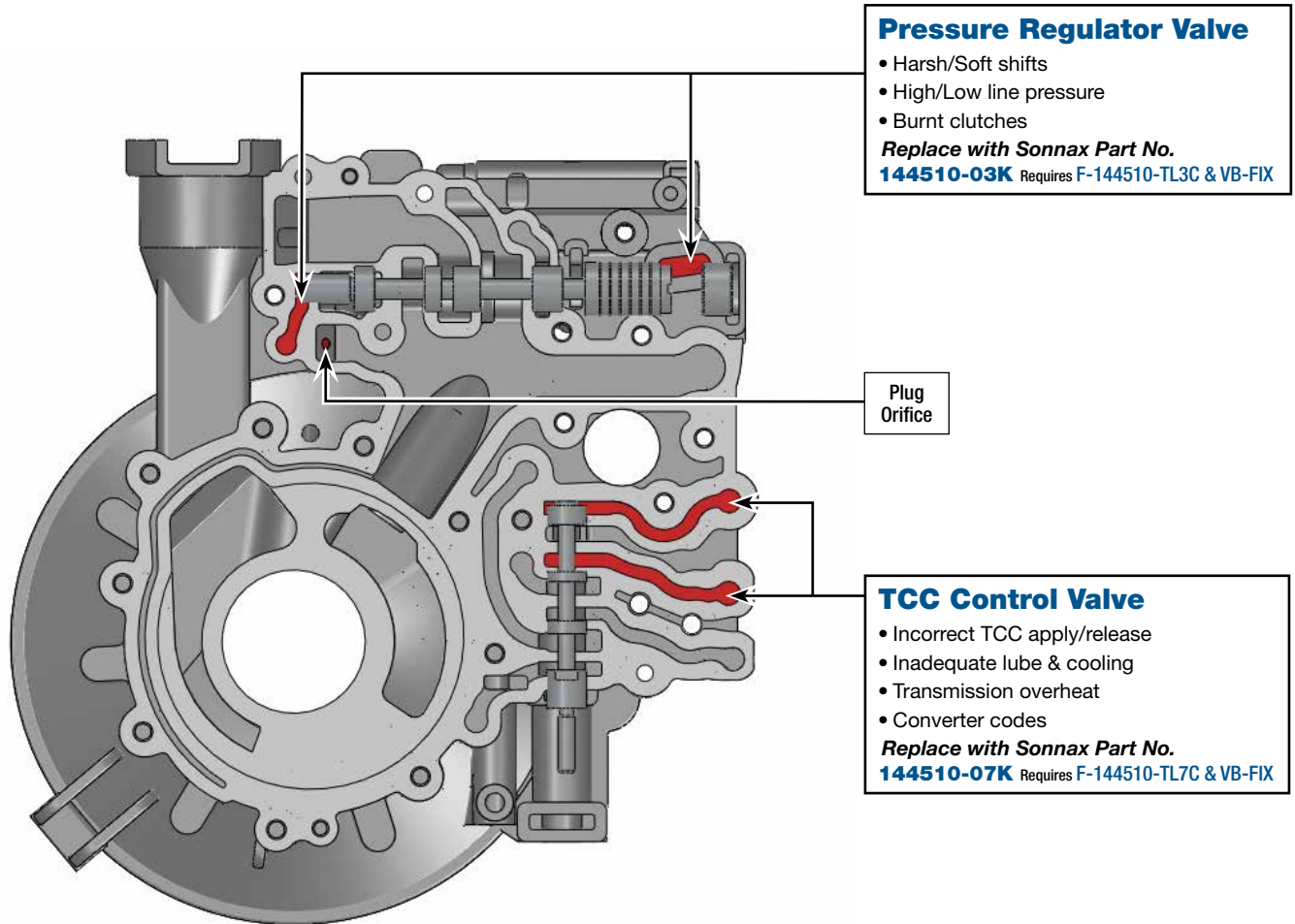

OE Exploded View

Main Control Valve Body

NOTE: Depending upon vehicle application, the OE springs shown may not be present.

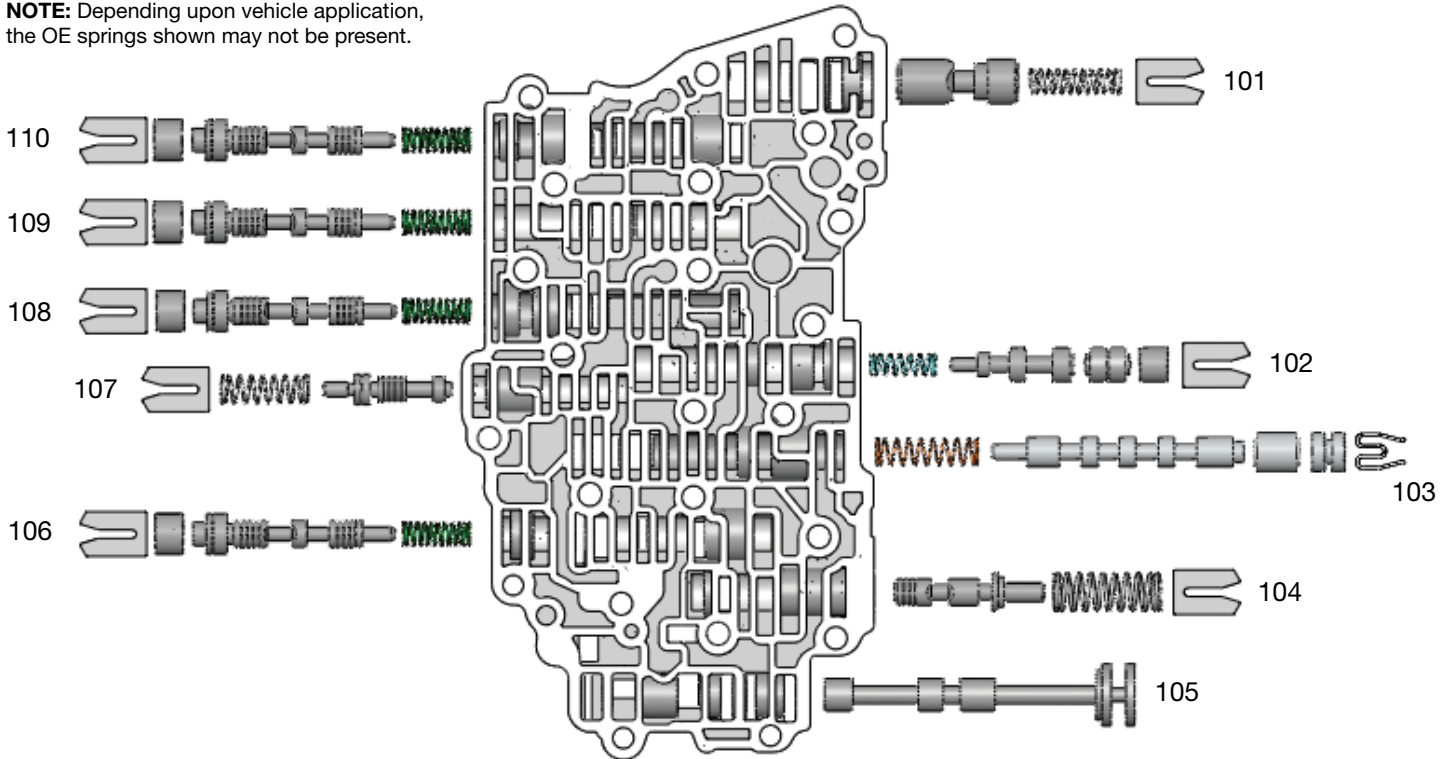

Solenoid Valve Body

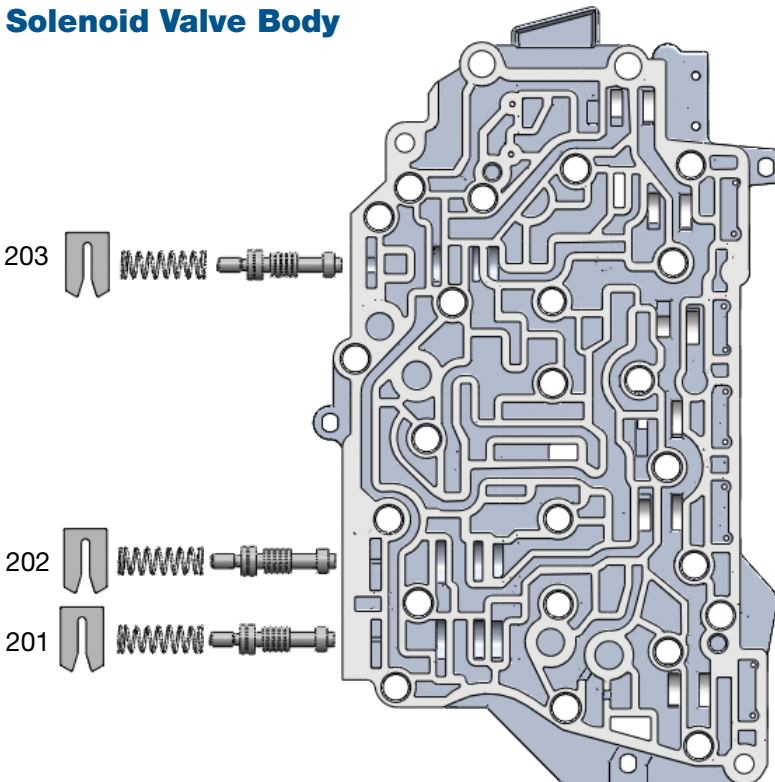

Main Control Valve Body Descriptions

I.D. No.	Description
101	Control Pressure Regulator Valve
102	TCC Regulator Valve
103	Clutch Bypass Valve
104	Solenoid Pressure Regulator Valve
105	Manual Valve
106	Low Reverse/Overdrive (4-5-6) Clutch Regulator Valve
107	Forward (1-2-3-4) Clutch Latch Valve
108	Forward (1-2-3-4) Clutch Regulator Valve
109	Intermediate (2-6) Clutch Regulator Valve
110	Direct (3-5-R) Clutch Regulator Valve

Solenoid Valve Body Descriptions

I.D. No.	Description
201	Direct (3-5-R) Clutch Latch Valve
202	Intermediate (2-6) Clutch Latch Valve
203	L/R Overdrive (4-5-6) Clutch Latch Valve

OE Exploded View

Pump Body

NOTE: Depending upon vehicle application, the OE springs shown may not be present.

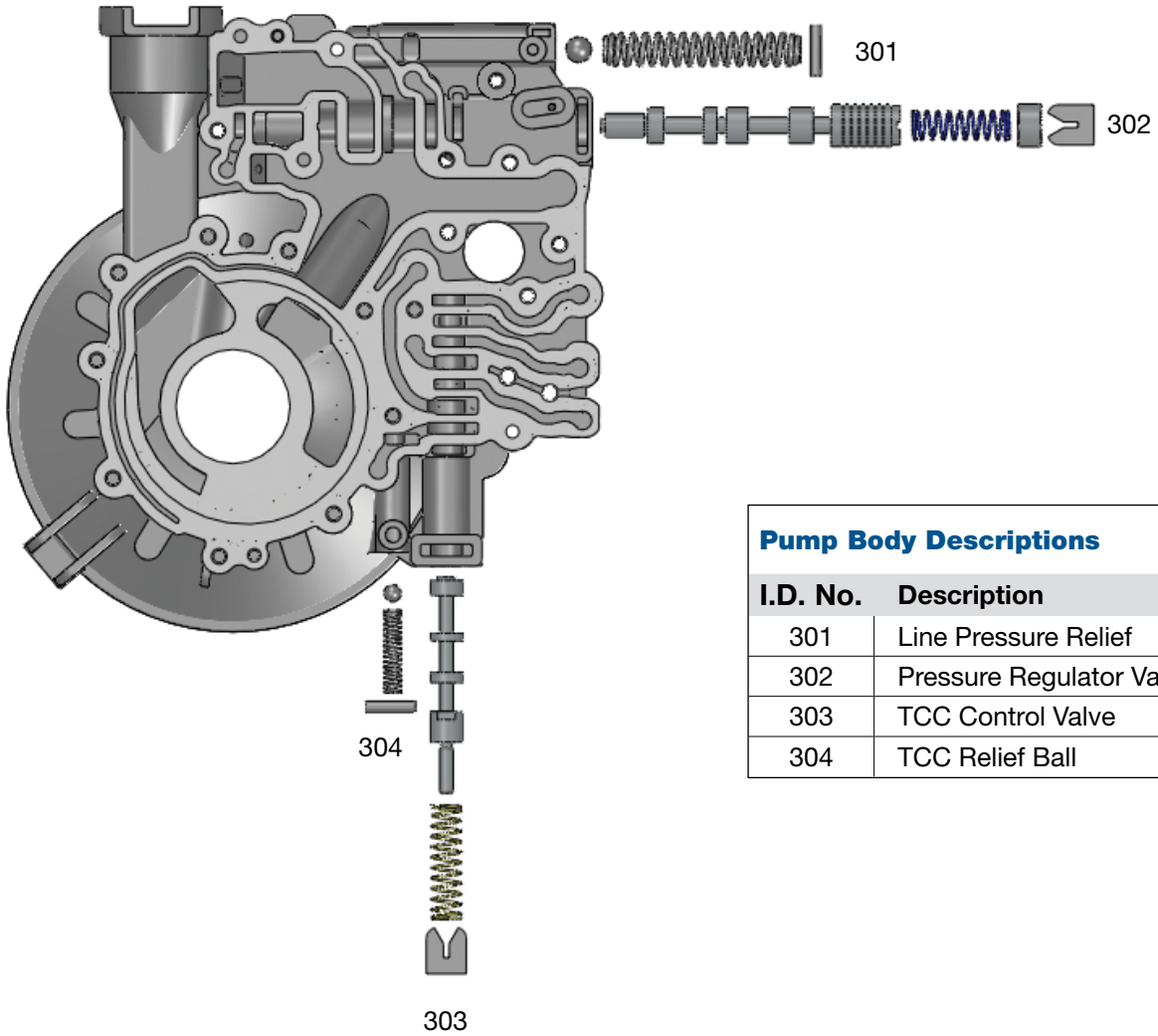

Pump Body Descriptions

I.D. No.	Description
301	Line Pressure Relief
302	Pressure Regulator Valve
303	TCC Control Valve
304	TCC Relief Ball