

Mazda JF506E Remanufactured Valve Body

Part No.

MAZ506



WARNING: This Mazda-style valve body cannot be interchanged with any other manufacturer.

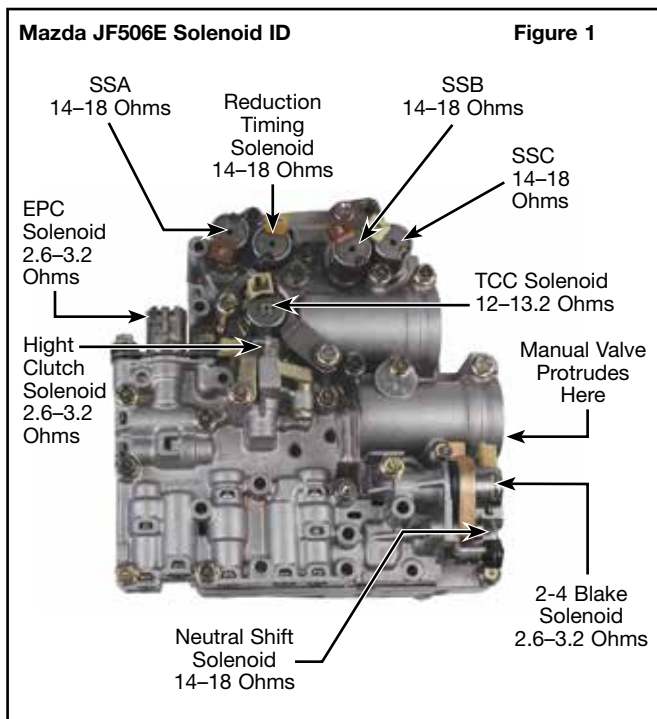

Valve Body Installation Tips

1. Valve Body

- a. In preparation for installation slide the manual valve to the far right. You should be able to see the groove at the end of the valve protruding from the right side of the valve body (**Figure 1**).

NOTE: A paper clip can hold the valve in place. Ensure that the manual shift linkage in the transmission is in Manual position. Install two new O-rings into the case (**Figure 3**). Verify valve body gaskets are not damaged and that the case mating surface is flat. Install the valve body onto the transmission case. Install the 10 valve body to case bolts and torque to 71 in-lb.

- b. Connect wire harness to solenoids on valve body using (**Figure 1**).

2. Fluid Fill & Road Test

- a. Fill the transmission with OE compatible fluid. Warm engine to 185°.
- b. Install capable scan tool and reset transmission adaptives.

NOTE: Battery disconnect will not reset adaptives.
- c. Road test vehicle after performing adaptive reset thru 10-15 upshift and downshift cycles at light throttle thru all 5 speeds. Perform 4-5 passing gear maneuvers at high speed.



NOTE: The 2-3 upshift can commonly flare and the upshift into 2nd and 4th can be harsh, along with coast downshifts while the transmission is re-adapting. A thorough road test should solve these complaints.

Transmission Diagnostic Tips

This remanufactured valve body has been through a rigorous inspection and rebuild process, then a comprehensive, functional hydraulic and electronic test to ensure it meets OE performance and quality. It is designed to eliminate many pressure-, shift- and converter-related complaints, but will not correct complaints that stem from other areas of the transmission.

The following are common areas of failure or root causes for symptoms that could be attributed to valve body issues that should also be examined or addressed during your transmission build. A clutch and brake application chart (Figure 2) is below for additional aid in diagnosing problems, as well as air test locations to verify clutch and brake circuit integrity (Figure 3).

- Slips in 3rd, 4th and 5th or has High and Reverse input clutch failure. This condition can be caused by a cracked high clutch piston on early applications.
- No Reverse and slips in Forward. This condition can be caused when the band anchor is removed from the transmission case, by mistake to fill the transmission. This allows the band to fall out of its anchor. This can also be caused by a mis-positioned valve body-to-case O-ring.

Clutch & Brake Application Chart

Figure 2

Gear Range	Low Clutch	2-4 Clutch	High Clutch	Reverse Clutch	Low/Reverse Clutch	Reduction Band	Direct Clutch	Low Roller Clutch	Reduction Sprag
Park/Neutral						ON			
Reverse				ON	ON	ON			
D-1 st Gear	ON					ON		ON	ON
D-2 nd Gear	ON	ON				ON			ON
D-3 rd Gear	ON		ON			ON			ON
D-4 th Gear	ON	ON	ON			ON			ON
D-5 th Gear	ON	ON	ON				ON		

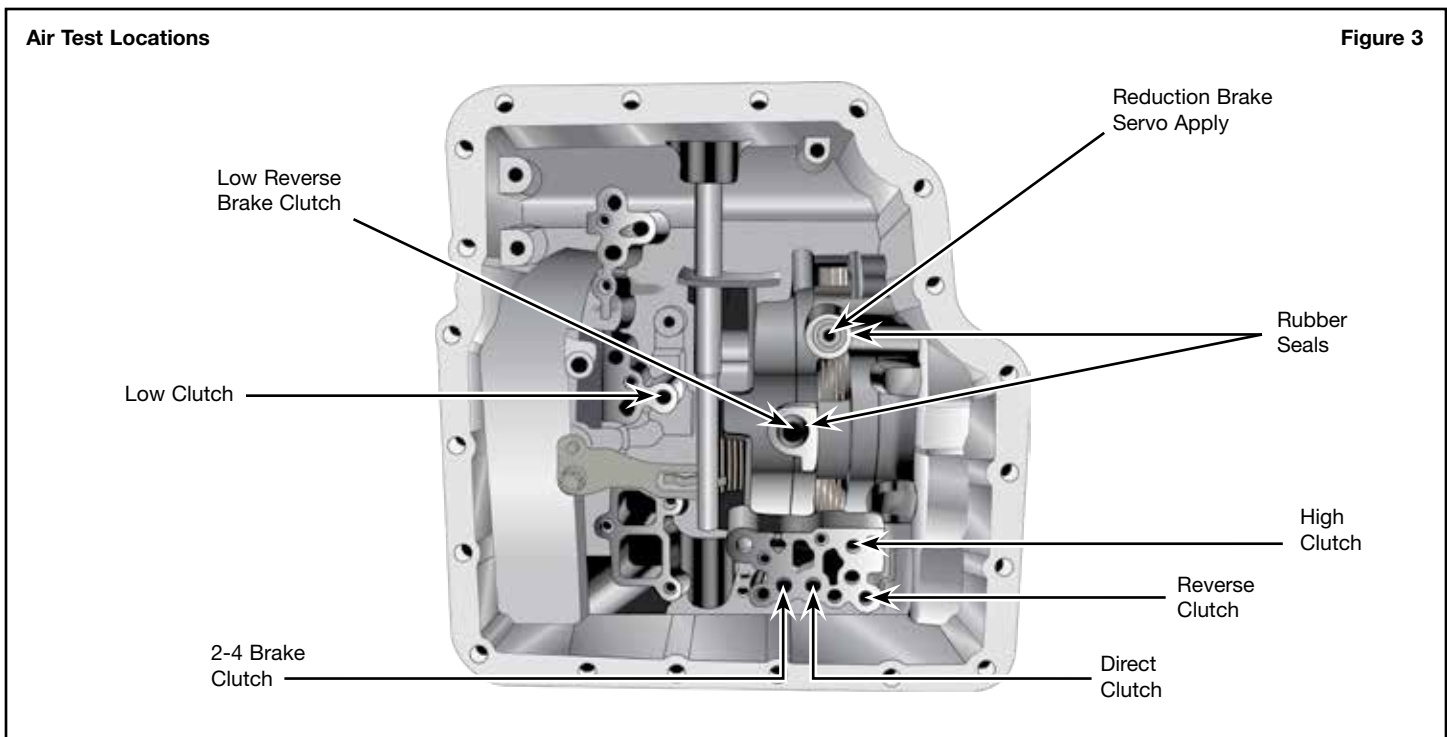

Figure 3