

**Sure Cure® Kit**



**Part No.**

**SC-4L60E**

**GM 4L60-E PWM**

**Valve Body Parts**

**TCC Regulator Valve Kit**

**77754-04K**

Patent Nos. 6,990,996 & 7,104,273

**NOTE:** This part requires tool kit **77754-R2**.

**AFL Valve Assembly**

**77754-09K**

Patent No. 6,634,377

**NOTE:** This part requires tool kit **77754-TL**.

**Pinless Acc. Piston Kit**

**77998-03K**

1-2 & 4<sup>th</sup>

Patent No. 6,899,211

**Servo Release**

**Check Valve Kit 77701-076**

**1-2, 3-4 Accumulator Spring**

**74926**

**Checkballs 10000-08 (8)**

**Valve Body Retainer Clip**

**77754-08**

**Forward & Reverse**

**Abuse Bore Plugs**

**77754-21 (2)**

**3-4 Relay Valve End Plug**

**77764-07**

**Pump Parts**

**Oversized Boost Valve &**

**Spacer (.490")** Patent No. 6,619,323

**TCC Apply Valve Kit**

**77805E-K**

**Oversized PR Valve**

**77917-07**

**NOTE:** This part requires tool kit **77917-TL**.

**Pump Slide Pivot Pin 65797**

**Pump Bushing 77005T**

**Reassembly Parts**

**D-Ring Servo Seals (5)**

**Endplay Shims**

**77406-10** .010"

**77409-15** .015"

©2012 Sonnax Industries, Inc.



**NOTE:** This kit is fully compatible with '95-later 4L60-E units with PWM/EC<sup>3</sup> (electronically controlled capacity clutch) control. These can be identified by the 13-pin case connector, PWM/TCC solenoid and PWM pump (five solenoids). All components in this kit are compatible '93-'94 non-PWM units EXCEPT the TCC apply valve **77805E-K** installed in the pump. These units can be identified by the 12-pin case connector, only having a 3-2 solenoid in valve body (four solenoids).

**The following tool kits are required to install this Sure Cure Kit:**

**NOTE:** Instructions are provided with these tool kits.

**Part No.**

**77754-R2**

Reamer



**NOTE:** For installing TCC regulator valve kit **77754-04K** in units with a .441" dia. isolator valve where the isolator bore is not worn.

If the valve measures .473" dia., you have a GM serviced valve body and have two reaming options (in either case you also will need to install Sonnax isolator sleeve kit **77754-ISO**):

- Ream the bore using tool kit **77754-SERV** followed by tool kit **77754-RM5**.
- Ream the bore with the **VB-FIX** reaming fixture and tool kits **F-77754-SERV** followed by **F-77754-TL4**.

**Part No.**

**77754-TL**

• Reamer



• Core Drill 4L80-E Only



• Reamer Jig 4L60-E Only



• Reamer Jig 4L80-E Only



• Drill Guide 4L80-E Only



• Drill Bit .051" (not shown)

**NOTE:** For installing AFL valve kit **77754-09K**.

This tool kit also works for 4L80-E AFL valve repairs.

**Part No.**

**77917-TL**

• Reamer



• Jig



**NOTE:** For installing oversized PR valve **77917-07**.

## CHECK BALL & VALVE BODY PART LOCATIONS

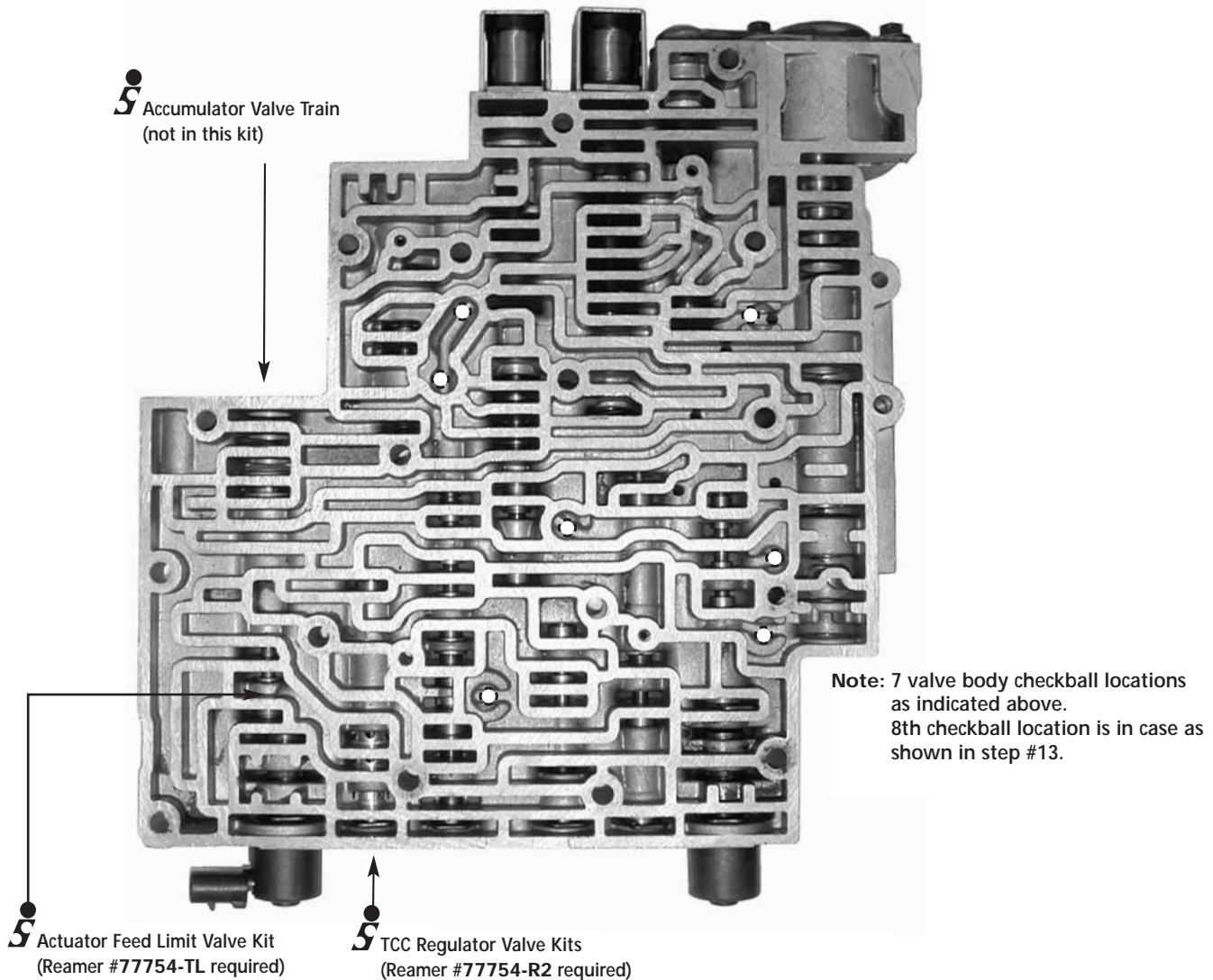

## Sure Cure Fast Version

If you need to get this job out the door in a hurry, then just follow **highlighted** steps below. The other steps are repair information (to help prevent NO GOs and CBs) & OEM part numbers that you can read at your convenience.

1. Bearing and planetary inspection
2. Case and bore prep
3. Servo seals
4. Pressure Regulator Valve
5. Boost Valve
6. Pump body
7. Pump cover
8. TCC apply valve inspection
9. TCC apply valve installation
10. Pinless accumulator pistons
11. Servo check valve

### 12. Separator plate modification

13. Checkball

14. Forward Abuse Bore Plug

17. AFL valve (tool required)

18. Separator plate modification

19. TCC regulator valve (tool required)

20. Reverse Servo Abuse Bore Plug

21. 3-4 Relay Valve End Plug

22. 3-2 Downshift Abuse Plug

## STEP 1 BEARING & PLANETARY INSPECTION (REASSEMBLY PARTS)

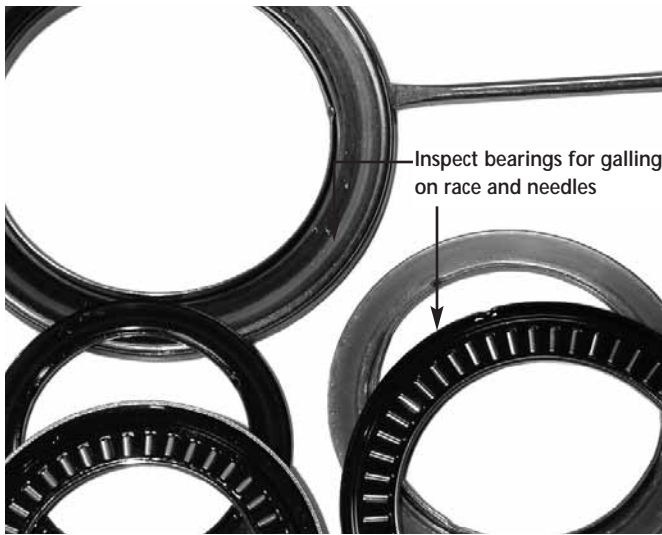

Note: Bearings can easily be pried open at the crimp. Ask for Torrington™ Bearing Kit SBK-G12.

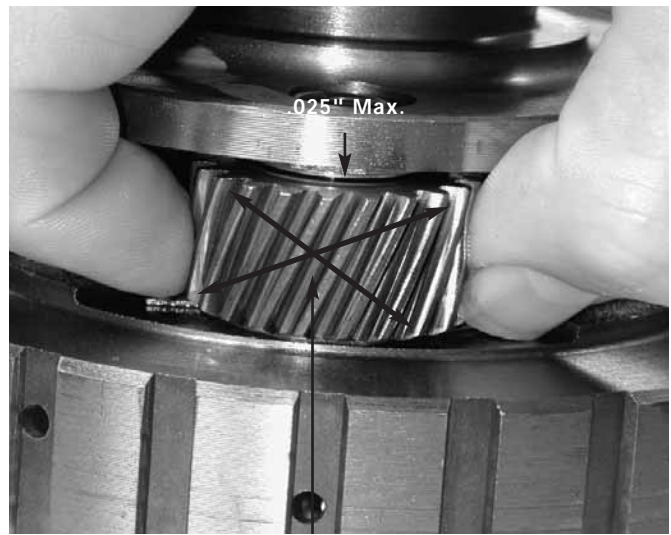

Inspect planet pins and endplay. No side to side movement

## STEP 2 PREPARE CASE, SERVO AND ACCUMULATOR BORES

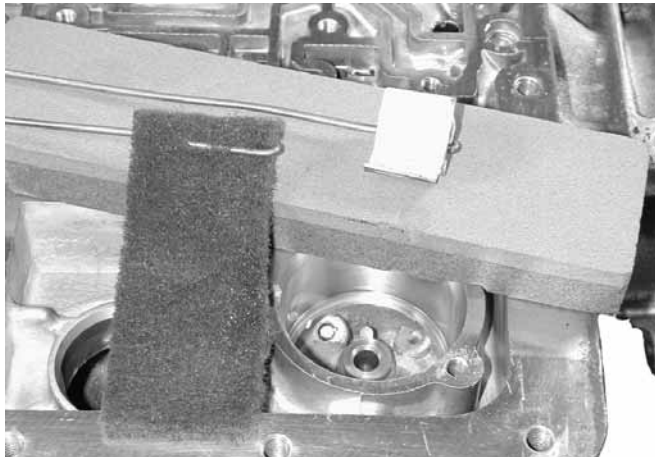

Use a fine grit stone to remove high spots on case and valve body. Scuff the accumulator(s) and servo bore with Red ScotchBrite™. A stiff wire or rod wrapped with material can be spun in a drill.

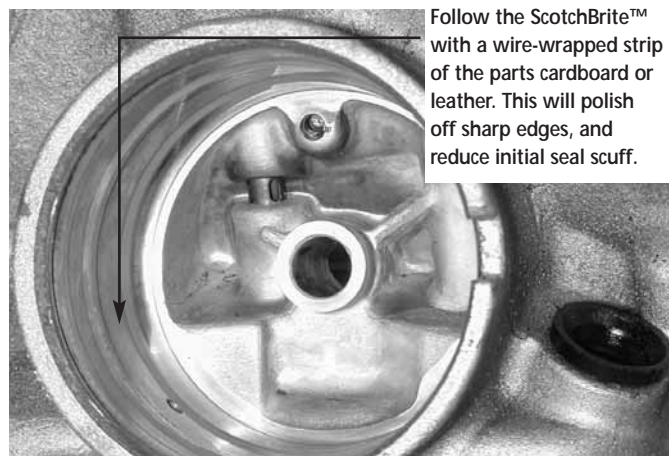

Note: Viton® seals require a surface that retains fluid to ensure long life. PREP SURFACES BEFORE CLEANING AND FINISH WITH SOLVENT.

## STEP 3 SERVO SEALS

Install Viton® Servo D-ring seals.

Discard OEM seal.

Prepare the seal surfaces on cover and inner housing as mentioned in previous step.

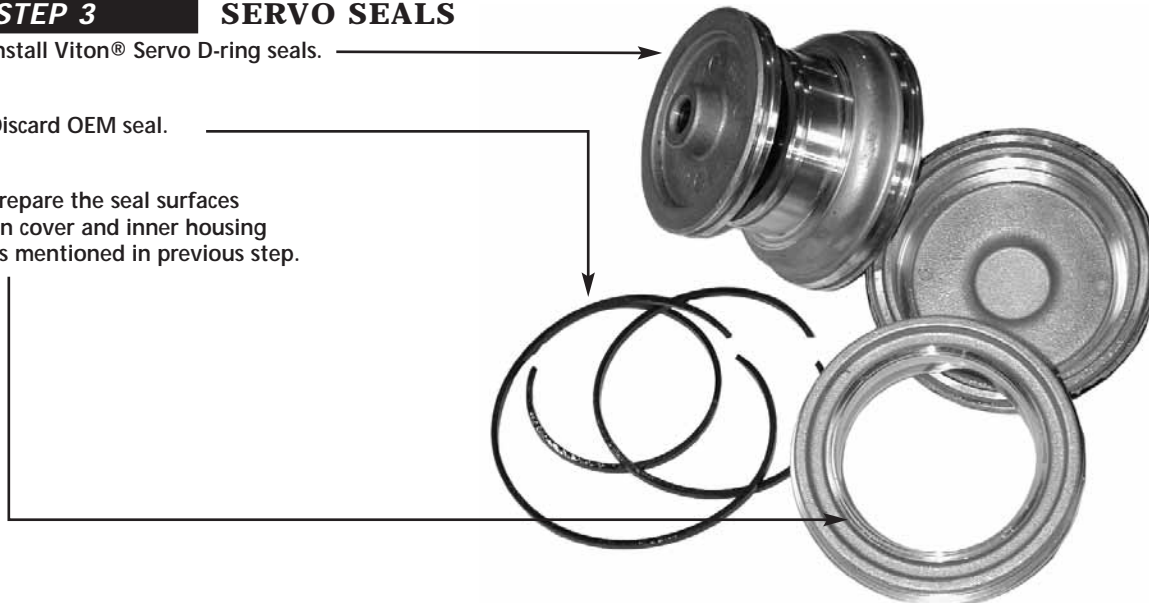

## STEP 4

## REAM & INSTALL PRESSURE REGULATOR VALVE

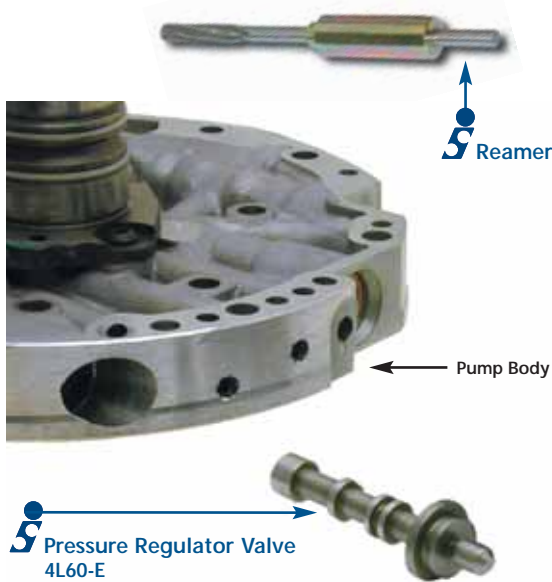

### Reaming Instructions

1. Remove and discard the OEM pressure regulator valve.
2. Clamp the pump housing securely to a bench.
3. Install the reamer and guide 77917-TL as shown in the figure above.
4. Flood the valve bore and reamer flutes with cutting fluid (Tap Magic™, kerosene, etc.).
5. Using a "low" RPM (500-600) drill, carefully ream the valve bore. Maintain a constant moderate clockwise rotation and apply steady forward pressure until the reamer reaches the bottom of the valve bore. The reamer should cut easily. Continue to turn the reamer clockwise as it is removed from the bore. Ream one pass only.
6. Remove any debris and burrs from the bore. Lubricate and install the Sonnax replacement valve.



## STEP 5

## BOOST VALVE

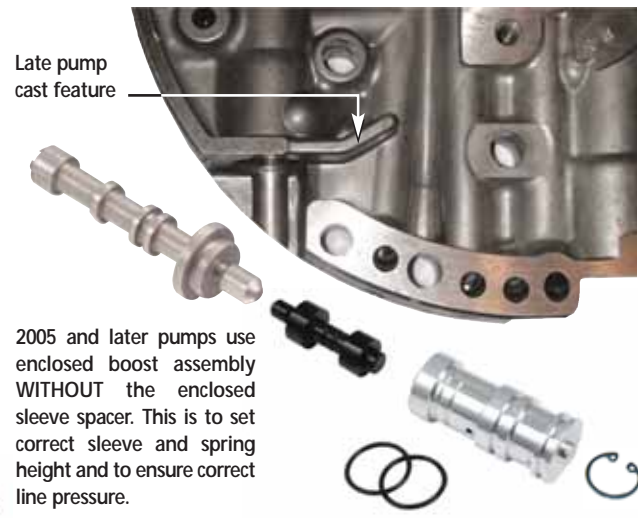

## STEP 6

## PUMP BODY PARTS INSTALLATION

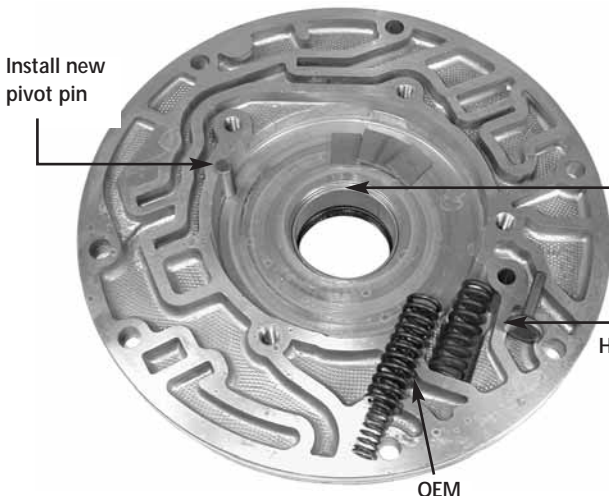

PTFE-coated pump bushing is inserted here as rebuild option. Butt gap bushing is not suggested unless the pump has anti-walk ridge. Surfaces must be prepared with #609 Loctite®. Butt gap should be placed at 12 o'clock position and installed using full end contact on arbor press.

Also available:  
Heavy Duty Slide Spring  
77722-01K

## STEP 7 PUMP COVER IDENTIFICATION



Remove the relief rivet and clean ball and seat. With severe contamination, reform the seat by tapping ball into it.  
**Note:** Don't forget to replace filter o-ring.

**Non PWM** —  
 If the casting has two parallel webs, it is NON PWM and takes valve 77805-K (Not included in Sure Cure)  
**PWM** —  
 If the casting has a bridge at this location, use valve 77805E-K in this kit (See also Step 13).

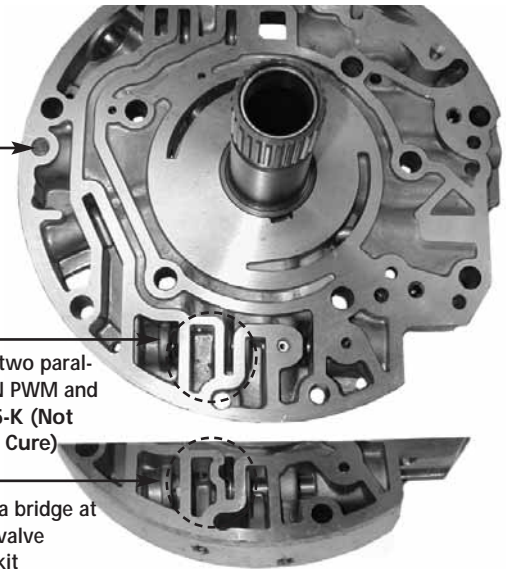

P/N 77805-K is not in this kit!

## STEP 8 TCC APPLY VALVE IDENTIFICATION

Photo at right shows the 3 different OEM 4L60 and 4L60-E TCC apply valves. Oil circuits differ, so it is critical NOT TO MISMATCH PWM versus non-PWM valves. OEM valve materials can be steel or aluminum, and should not be used for identification. A double spool at the indicated location can be used to determine PWM versus non-PWM valves.

Sonnax kit 77805E-K, included, can be used in both early and late PWM applications. Discard OEM valve and spring(s), and replace with complete valve and seal kit.

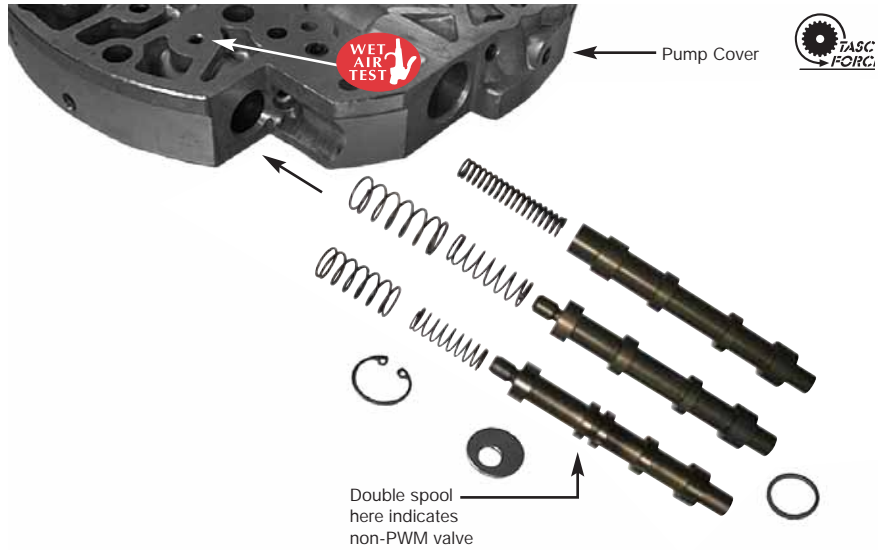

## STEP 9 TCC VALVE INSTALLATION

PTFE seal resize

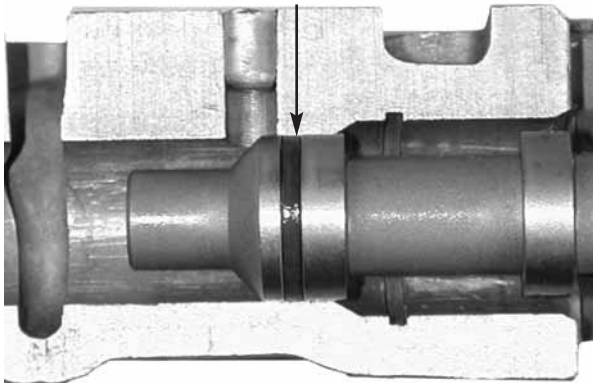

PTFE seal supplied must be stretched to install into valve groove. Resize with finger pressure, pre-lube, then resize by inverting into bore.

Insert 1/8" or up to seal only. Let it stand for a few minutes.

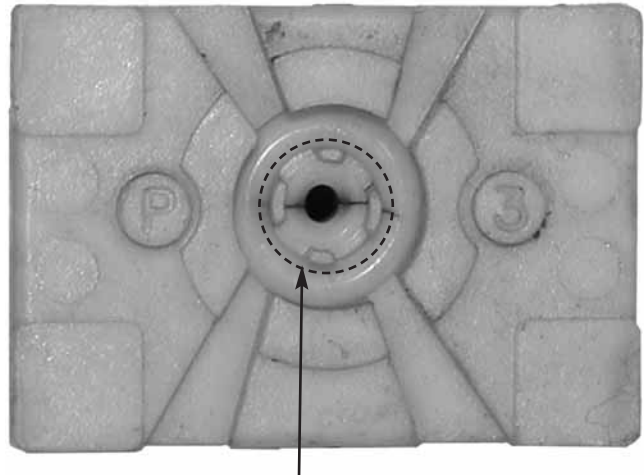

Inspect the TCC solenoid seat for cracks.

## STEP 10 PINLESS SONNAX ACCUMULATOR PISTONS

OEM pin must be driven from cover.

Plug pin holes by driving either the large or small steel checkballs into the hole. Lightly stake the pin bore after installing the ball.

### Reassembly:

- Pre-1994 - 4th piston - Install dome into case with spring in pocket.
- 1-2 piston - Install dome into accumulator body followed by purple spring.
- 1994 later - 4th piston - Install dome into case. Some units do not have a spring for 4th accumulator. If OEM had a spring, install into piston pocket.
- 1-2 piston - Install spring(s) into accumulator body, set piston pocket opening onto spring, dome toward plate.  
(Patent Pending)

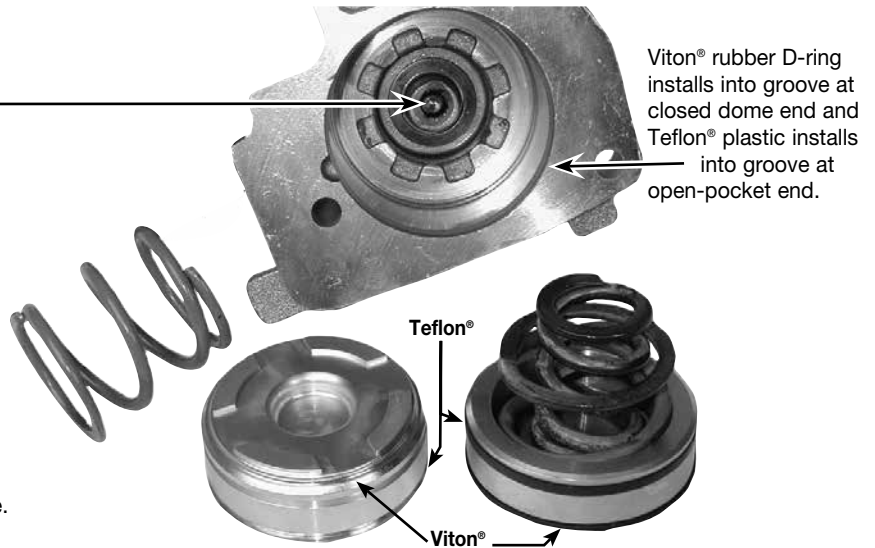

## STEP 11 SERVO RELEASE CHECK VALVE

**NOTE:** Before installing servo release check valve, make sure the 3rd accumulator checkball capsule is in the case and there are no leaks. Replace a leaking capsule with OE p/n 8634400.

- If necessary adjust orifice "A" in valve to match servo being used (see info to right).
- Tapered end goes in first. Valve must be driven flush with case surface and must be tight.
- Install into case without included O-ring. If fit is loose, install included O-ring on check valve and reinstall.
- Adjust separator plate orifice "C" to match vehicle (see step 19).



Some cases bores may be oversized. Use o-ring on check valve for these bores only. If valve goes into bore without resistance, install the o-ring.

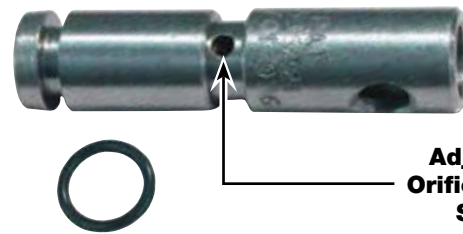

- If the last three servo casting numbers are 553, 554 or 159, or any servo with 2.312" to 2.520" small diameter piston, Sonnax valve installs "as is".
- If the last three digits are 093, or the servo is a one-piece aftermarket; enlarge the orifice "A" (at center groove) to .120"-.125".

## STEP 12 SEPARATOR PLATE 3-4 CLUTCH FEED IMPROVEMENT

Set up the plate to match your vehicle needs: A larger separator plate feed hole-C- will result in a shorter 2-3 shift. Too large, and a bumpy 2-3 will result. Locate the 3-4 clutch feed -C- orifice in your plate.

### "C" - Transmission 4L60-E

Application	Orifice Dia.
Regular Duty	No Plate Modification
Moderate Performance	.090"
Maximum Performance	.100"

Check valve can be removed by threading it (5/16" x 18") and using a bolt-on slide hammer or #5 easy out.

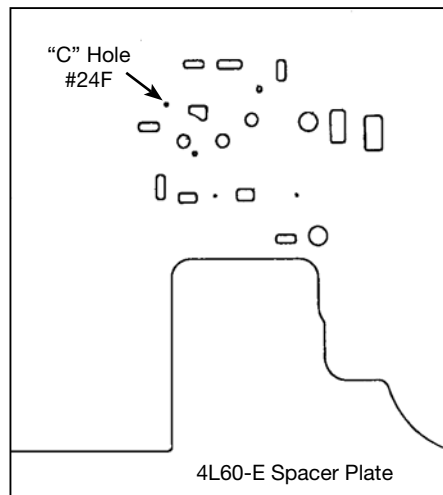

The Sonnax check valve will be installed with the OE 3rd accumulator check valve (OE part #8634400).

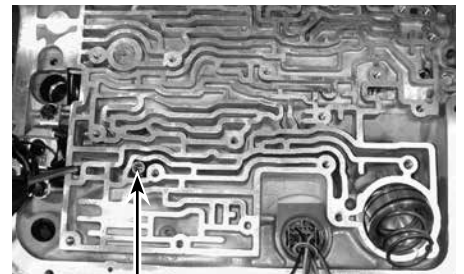

The check valve installs on top of the OE 3rd accumulator capsule.

### STEP 13

## CHECKBALLS AND ASSEMBLY TIPS



Non-PWM

If you are installing this kit in the vehicle, checkballs must be loaded into valve body.

Valve body checkball locations shown here and picture of checkball and valve body part locations shown before Step 1.

Do not use excessive lube, as balls will not seat until lube melts.

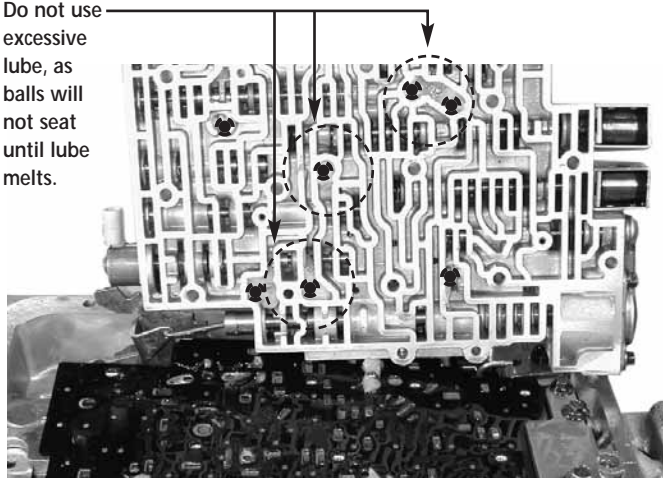

Supply 12 volts to TCC solenoid and WAT here. TCC valve in pump will stroke.

Drill bit used to check low-reverse clutch clearance (clutch clearance on spec sheet).

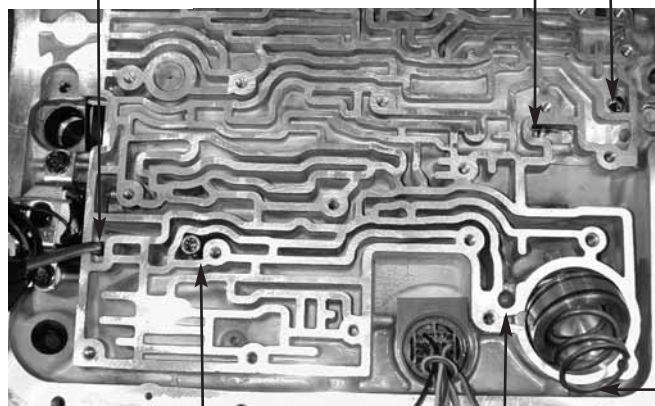

Servo check valve from step 11

Case checkball

4th accumulator pre-assembled

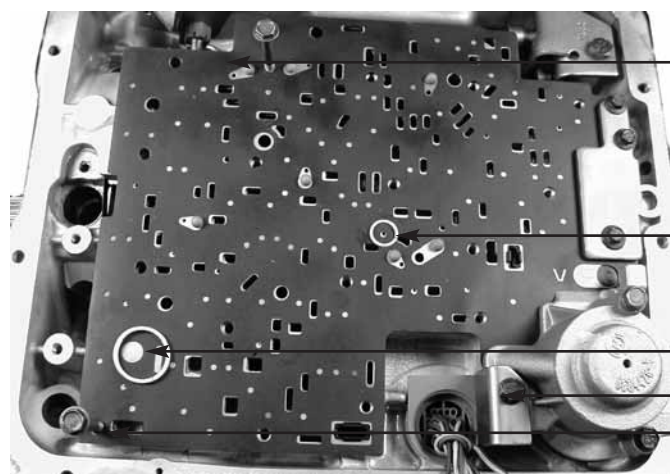

Note checkball locations

Orifice "C" for check valve modification in step 20

Plate with holes is PWM

Plate without holes is not PWM

Case connector retainer #77980-01K

Note alignment holes in plate

### STEPS 14-22

### STEPS 14 TO 22 INDICATED BY NUMBER ON VALVE BODY

#### STEP 14:

With forward accumulator cover still off, remove low-overrun valve and roll pin.

Pull out the divider plug and replace with abuse bore plug in kit.

#### STEP 15:

Reassemble forward accumulator.

#### STEP 16:

Update shift solenoids, replace o-rings.

Solenoid information in specifications.

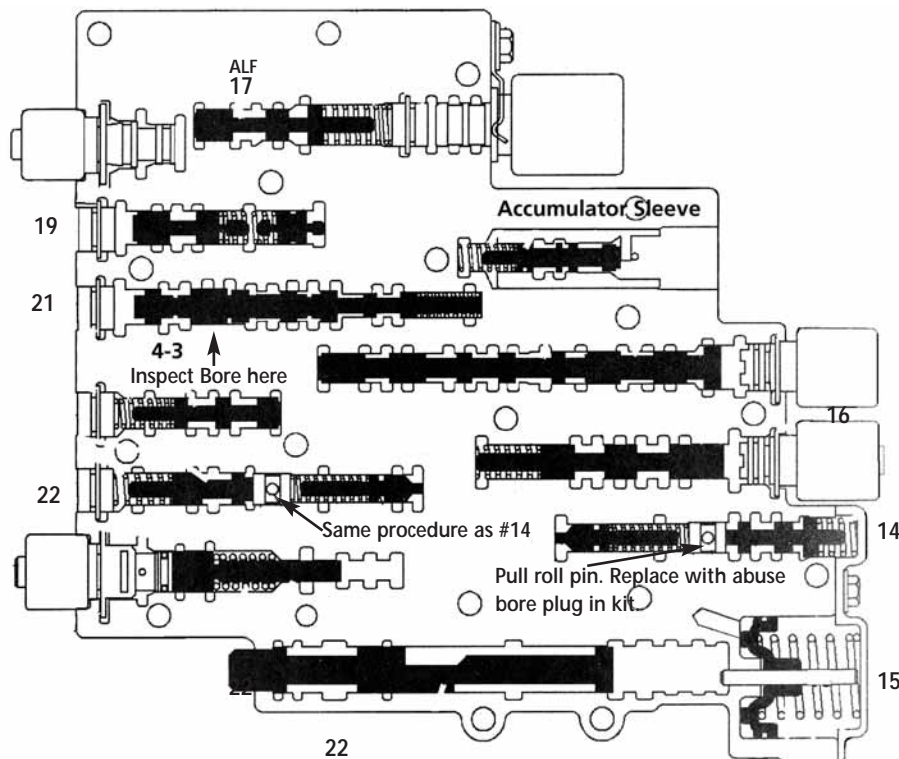

## STEP 17 AFL BORE INSPECTION AND REPAIR

AFL should not have movement

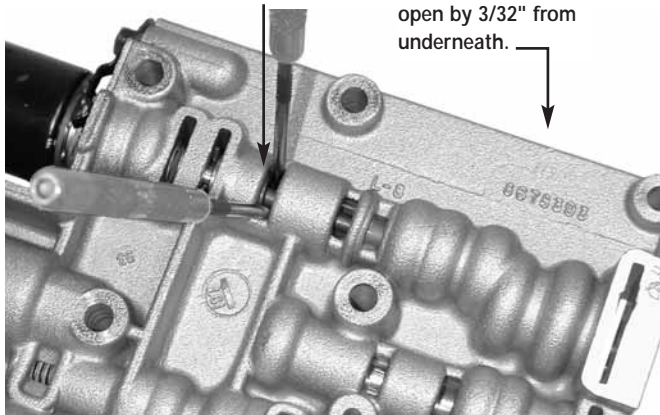

Prop the AFL valve open by 3/32" from underneath.

Remove EPC solenoid, clean the screen and replace filters in plate.

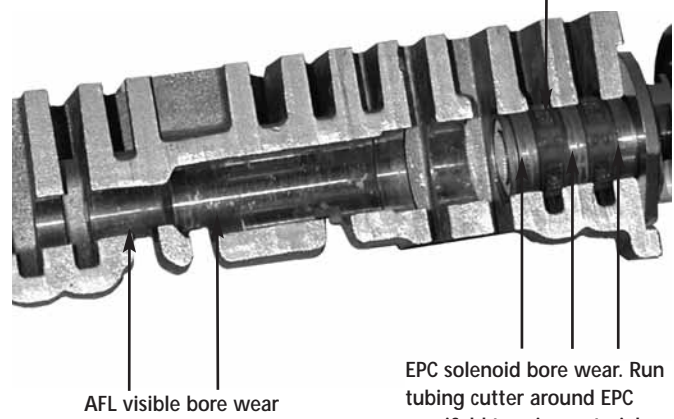

**Note:** Reamer kit 77754-TL required. Also works on 4L80-E. 4L60-E uses marked reamer and guide. No pre-drilling required.

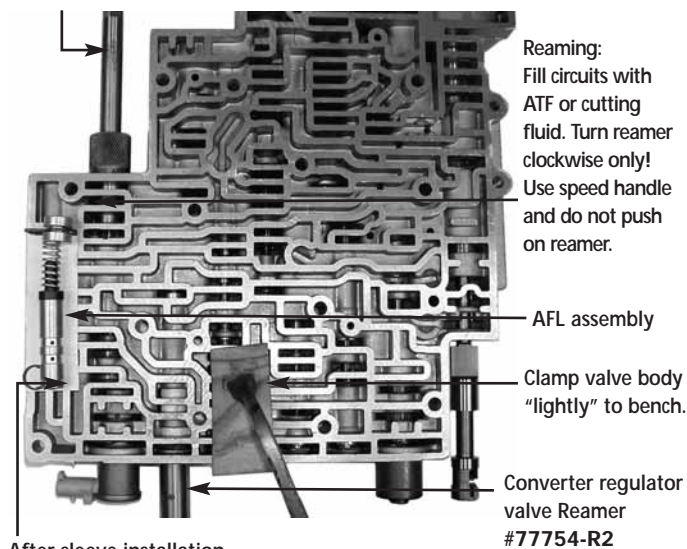

After sleeve installation "poodle clip" pushes into sleeve groove at channel indicated.

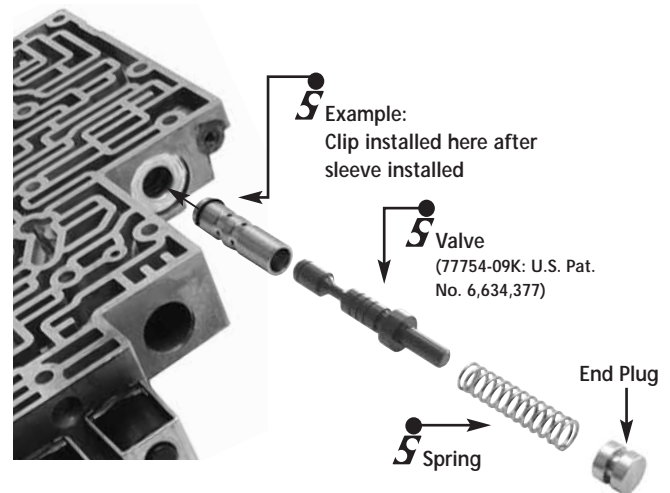

## STEP 18 AFL BALANCE HOLE MODIFICATION

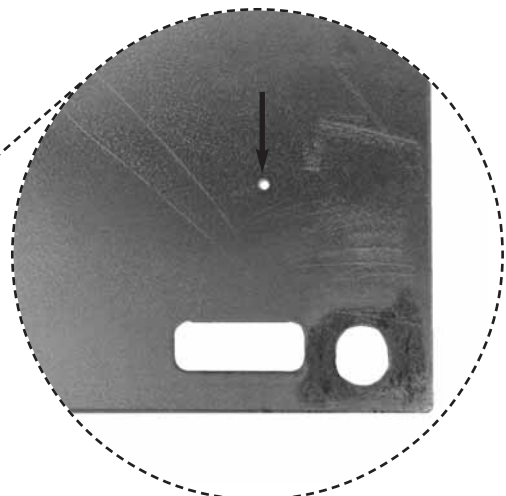
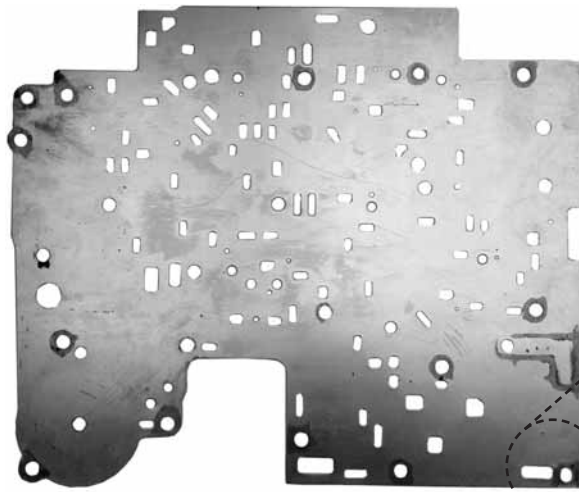

When AFL valve & sleeve are installed, the AFL balance hole in plate must be opened with drill supplied in reamer kit.

Enlarge the indicated balance AFL orifice to .052" with the drill bit supplied in reamer kit.

**STEP 19**

**CONVERTER REGULATOR VALVE DESIGN VARIATIONS:**



1993-Up  
.441" diameter

Remanufactured SERV stamped into casting, valve same O.D. as 12mm wrench (.473").  
**DO NOT ATTEMPT TO RE-REAM A SERV VALVE BODY WITH 77754-R2**

"SERV" stamped here indicates a "reamed" valve body

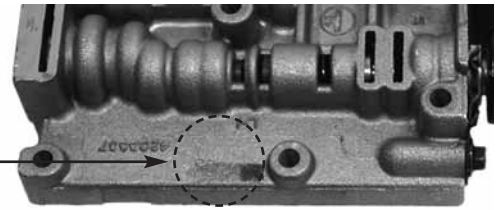

Valves from "SERV" valve body



2001-Up valve body



1997 EC<sup>3</sup> to 2000



1996-1997 non-EC<sup>3</sup> line-up



1994-1995 PWM line-up



1993-1994 non-PWM line-up



Sonnax valves repair these OEM designs

Casting Number ID-1993 up to 2000

Wide 1st design TCC regulator exhaust

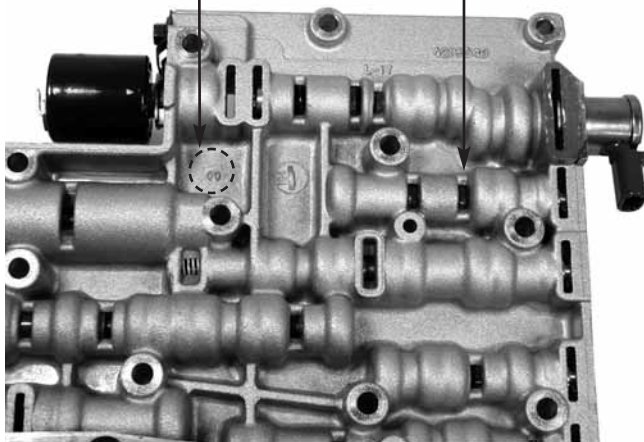

Casting Number ID 2001

Updated, full annular exhaust

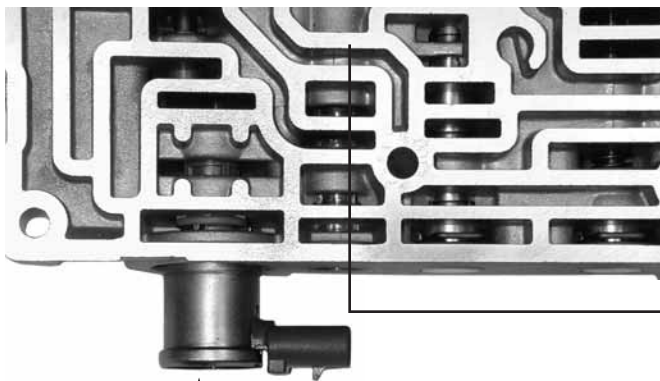
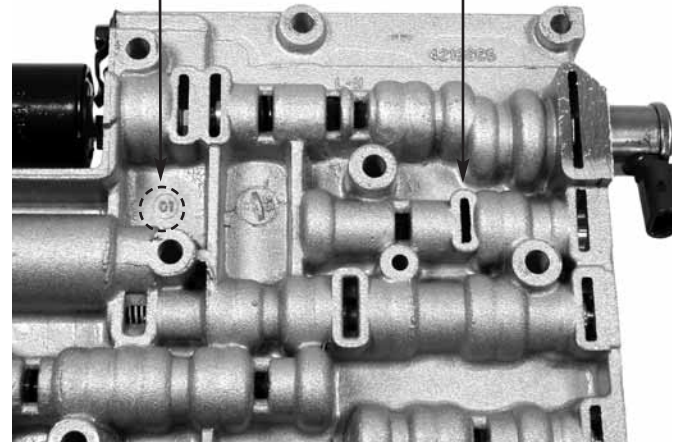

Update TCC/PWM Solenoid to GM P/N 24212690

- Remove OEM converter regulator valve
- Ream this bore with 77754-R2 (sold separately)
- Lightly clamp to bench, this side up.
- Fill circuits with ATF/ cutting fluid.
- Turn reamer with speed handle.
- Ream, turning clockwise only.
- Blow chips free before removal.
- Never turn counterclockwise!
- If tight assembly, repeat with 500 RPM drill.

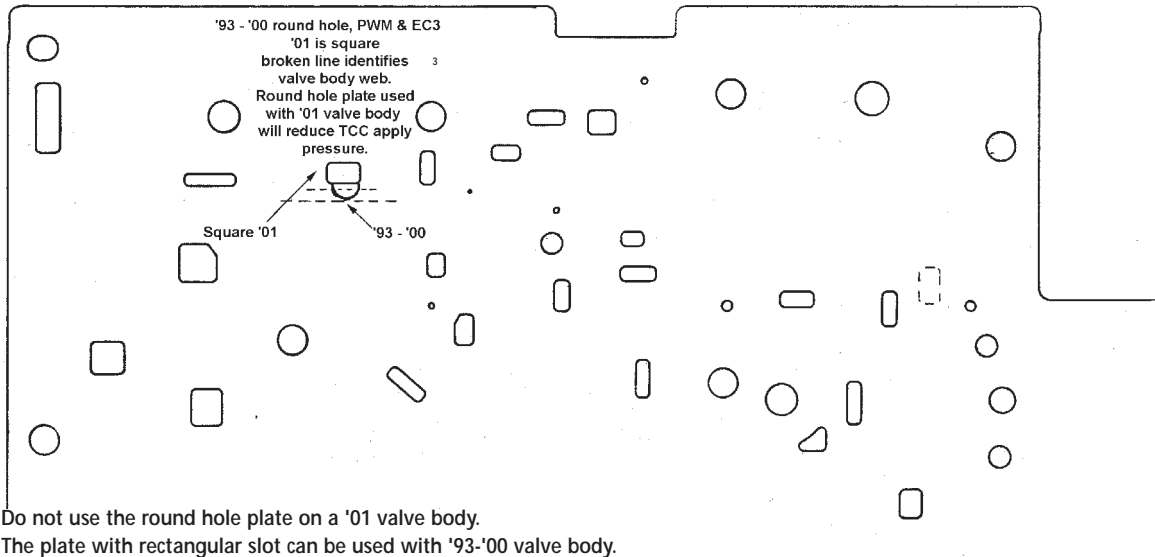

**Sonnax installed - Non-PWM**

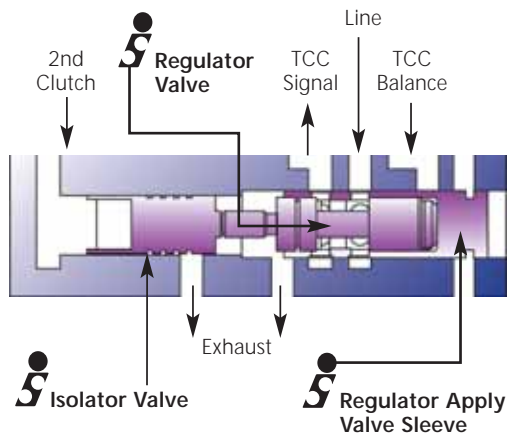

**Sonnax installed - PWM**

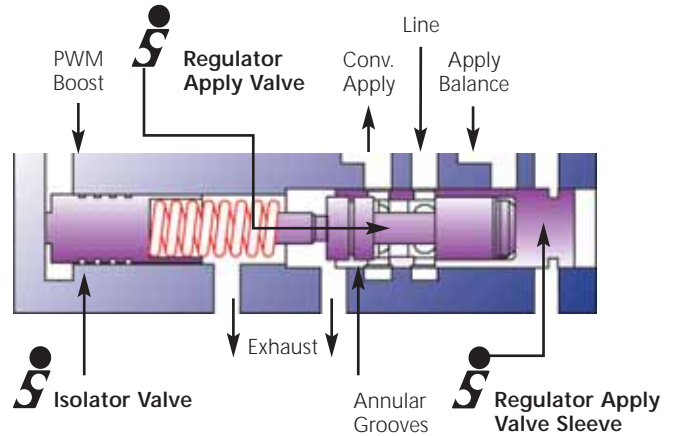

**STEPS 21-22 BORE INSPECTION (LEFT: 3-4 RELAY, RIGHT: 3-2 DOWNSHIFT)**

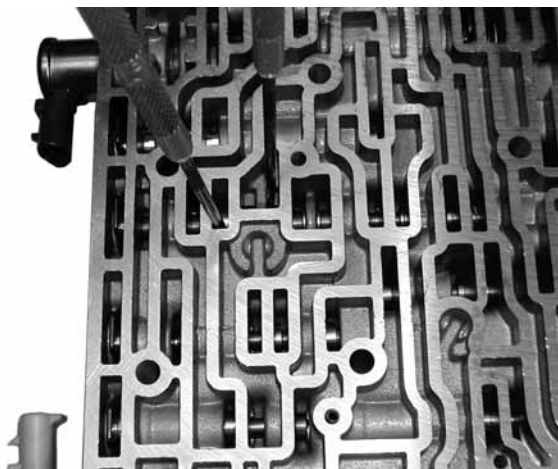

21. Inspect bore for wear at the 3-4 valve using wiggle test as shown. Replace end plug with o-ringed end plug provided.

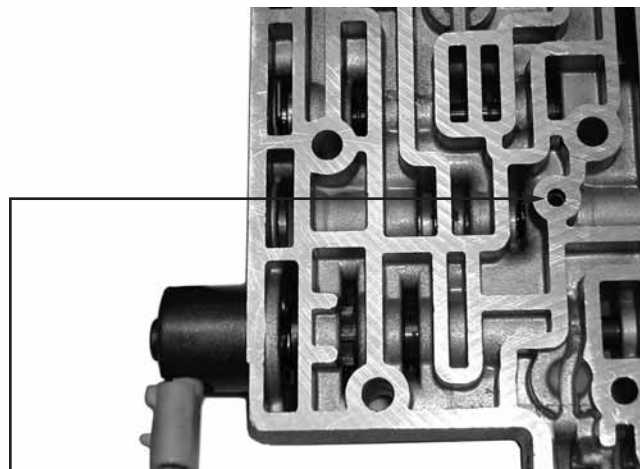

22. Remove 3-2 downshift assembly to remove the inner plug and replace with abuse plug provided.



# WET AIR TESTS

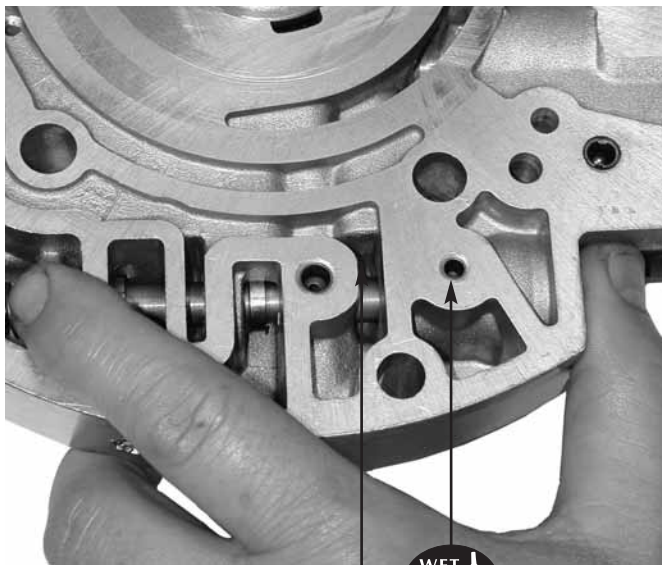

Use ATF here to identify leakage



Test at Orifice Plug

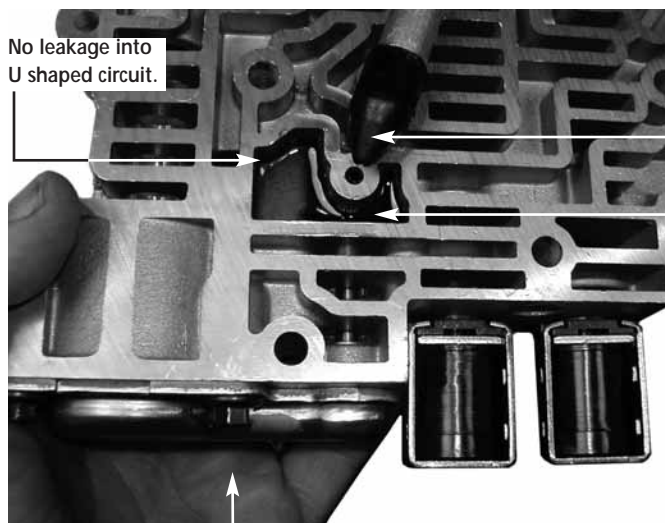

No leakage into U shaped circuit.

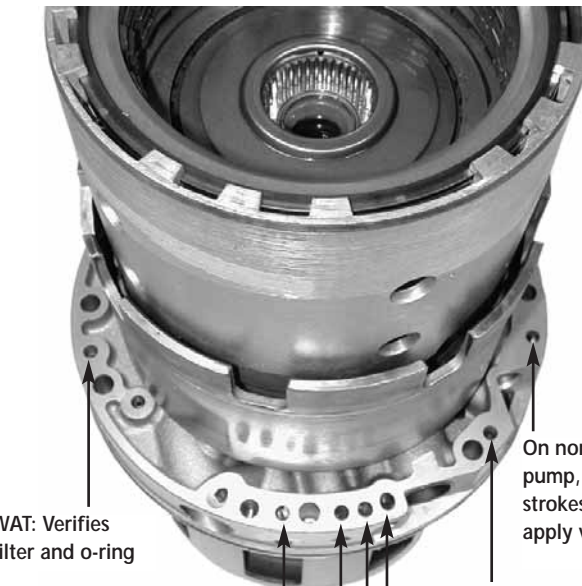

WAT: Verifies filter and o-ring

On non-PWM pump, air psi strokes TCC apply valve.

Reverse: No checkball leaks No leaks at torque signal

Plug off forward, WAT overruns, No 3-4 piston movement!

3-4 clutch: Overrun, no piston movement

Forward clutch, No 3-4 apply!

Torque signal: No leakage from reverse

Pressurize roll pin from machined side.

Place fluid into the U-shaped cavity over lo-overrun valve.

When WAT 3-4 clutch: No oil loss at checkball, or base of shaft.

Close off roll pin under the valve body w/finger.

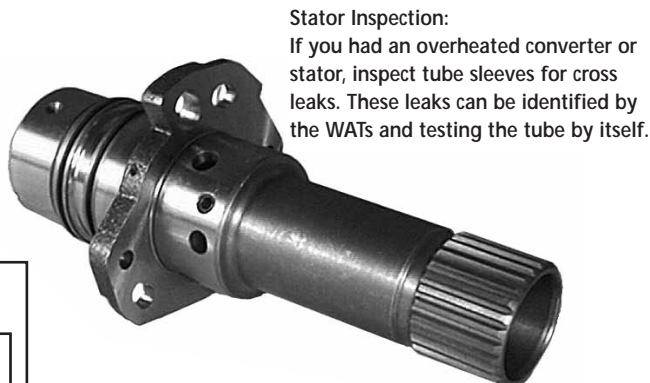
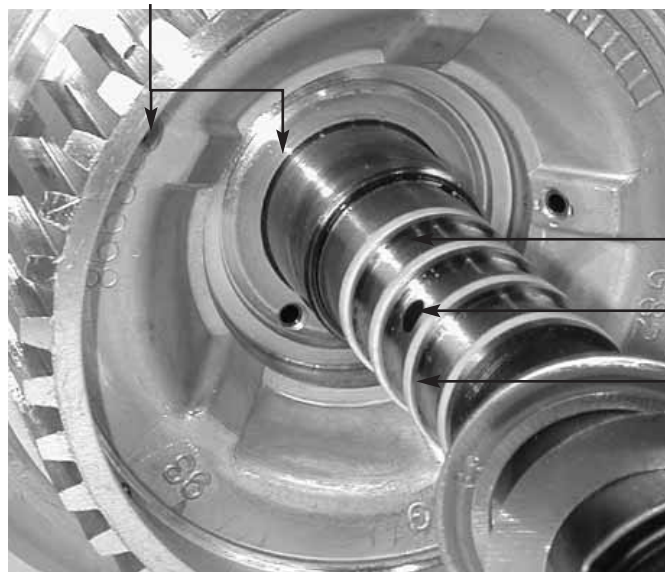

Stator Inspection: If you had an overheated converter or stator, inspect tube sleeves for cross leaks. These leaks can be identified by the WATs and testing the tube by itself.

Note: A 100% leak tested shaft, 77918S-K or 77918S-1K, are available from Sonnax.

3-4 Clutch  
Forward  
Overrun Clutch

2005 & later stator shafts are not interchangeable with 2004 & earlier shafts.

07/21/04