

SONOS®



Sonos® Digital Music System

ZoneBridge™

Setup Guide • Installatiehandleiding • Installationshandbok • Guide d'Installation
Guida all'installazione • Installationshandbuch • Guía de configuración

Sonos® ZoneBridge™

Setup Guide	1
Installationshandbuch.....	17
Installatiehandleiding	35
Installationshandbok.....	53
Guide d'installation.....	71
Guía de configuración	89
Guida all'installazione	107

Contents

Sonos® ZoneBridge™ Setup Guide. For use with the Sonos Digital Music System.

THIS DOCUMENT CONTAINS INFORMATION THAT IS SUBJECT TO CHANGE WITHOUT NOTICE.

No part of this publication may be reproduced or transmitted in any form or by any means, electronic or mechanical, including but not limited to photocopying, recording, information retrieval systems, or computer network without the written permission of Sonos, Inc.

Sonos is a registered trademark of Sonos, Inc. in the United States, and a trademark of Sonos, Inc. in other countries. Sonosnet, ZonePlayer, ZoneBridge, and all Sonos logos are trademarks of Sonos, Inc. in the United States and/or other countries.

Macintosh® and Mac OS® are trademarks of Apple Computer, Inc., registered in the U.S. and other countries.

Windows Vista™ and Windows® XP are either registered trademarks or trademarks of Microsoft Corporation in the United States and/or other countries.

This product includes technology owned by Microsoft Corporation and under a license from Microsoft Licensing, GP. Use or distribution of such technology outside of this product is prohibited without a license from Microsoft Corporation and/or Microsoft Licensing, GP as applicable.

MPEG Layer-3 audio decoding technology licensed from Fraunhofer IIS and Thomson.

Sonos uses MSNTP software, which was developed by N.M. Maclaren at the University of Cambridge.

© Copyright, N.M. Maclaren, 1996, 1997, 2000; © Copyright, University of Cambridge, 1996, 1997, 2000.

All other products and services mentioned may be trademarks or service marks of their respective owners.

© 2004-2007 by Sonos, Inc. All rights reserved.



For the latest product documentation, including the Sonos Digital Music System User Guide, go to www.sonos.com/support and click **Documents**.

ZoneBridge Setup Guide

Version: 070901

Regulation Information

For product available in the USA/Canada market, only channel 1-11 can be operated. Selection of other channels is not possible. This device and its antenna(s) must not be co-located or operated in conjunction with any other antenna or transmitter. Any changes or modifications not expressly approved by the manufacturer may void the user's authority to operate the equipment under FCC and IC rules.

USA

This device complies with part 15 of the FCC Rules. Operation is subject to the following two conditions: (1) this device may not cause harmful interference, and (2) this device must accept any interference received, including interference that may cause undesired operation. This equipment has been tested and found to comply with the limits for a Class B digital device, pursuant to part 15 of the FCC Rules. These limits are designed to provide reasonable protection against harmful interference in a residential installation. This equipment generates, uses and can radiate radio frequency energy and, if not installed and used in accordance with the instructions, may cause harmful interference to radio communications. However, there is no guarantee that interference will not occur in a particular installation. If this equipment does cause harmful interference to radio or television reception, which can be determined by turning the equipment off and on, the user is encouraged to try to correct the interference by one or more of the following measures:

- Reorient or relocate the receiving antenna.
- Increase the separation between the equipment and receiver.
- Connect the equipment into an outlet on a circuit different from that to which the receiver is connected.
- Consult the dealer or an experienced radio/tv technician for help.

This equipment complies with FCC radiation exposure limits set forth for an uncontrolled environment. This equipment should be installed and operated with minimum distance 20cm between the radiator & your body.

Canada

This Class B digital apparatus complies with Canadian ICES-003 and RSS-210. Operation is subject to the following two conditions: (1) this device may not cause interference, and (2) this device must accept any interference, including interference that may cause undesired operation of the device.

Industry Canada

To reduce potential radio interference to other users, the antenna type and its gain should be so chosen that the equivalent isotropically radiated power (e.i.r.p) is not more than that permitted for successful communication. The installer of this radio equipment must ensure that the antenna is located or pointed such that it does not emit RF field in excess of Health Canada limits for the general population; consult Safety Code 6, obtainable from Health Canada's Web site www.hc-sc.gc.ca/rpbc.

For product available in the USA/Canada market, only channel 1-11 can be operated. Selection of other channels is not possible. This device and its antenna(s) must not be co-located or operated in conjunction with any other antenna or transmitter.

RF Exposure Requirements

This equipment complies with IC RSS-102 radiation exposure limits set forth for an uncontrolled environment. This equipment should be installed and operated with minimum distance 20cm between the radiator & your body.

Europe

This product complies with the requirements of the R&TTE Directive (1999/5/EC). A copy of the full Declaration of Conformance may be obtained at <http://eu.sonos.com>.

☐☐ Attention In France, operation is limited to indoor use within the band 2.454-2.4835 GHz.
(Attention. En France, l'utilisation en intérieur est limitée à la bande de fréquences 2,454-2,4835 GHz.)

Recycling Information



This symbol on the product or on its packaging indicates that this product shall not be treated as household waste. Instead please deliver it to the applicable collection point for the recycling of electrical and electronic equipment. By recycling this product correctly, you will help conserve natural resources and prevent potential negative environmental consequences. For more detailed information about recycling of this product, please contact your local city office, your household waste disposal service or the shop where you purchased the product.

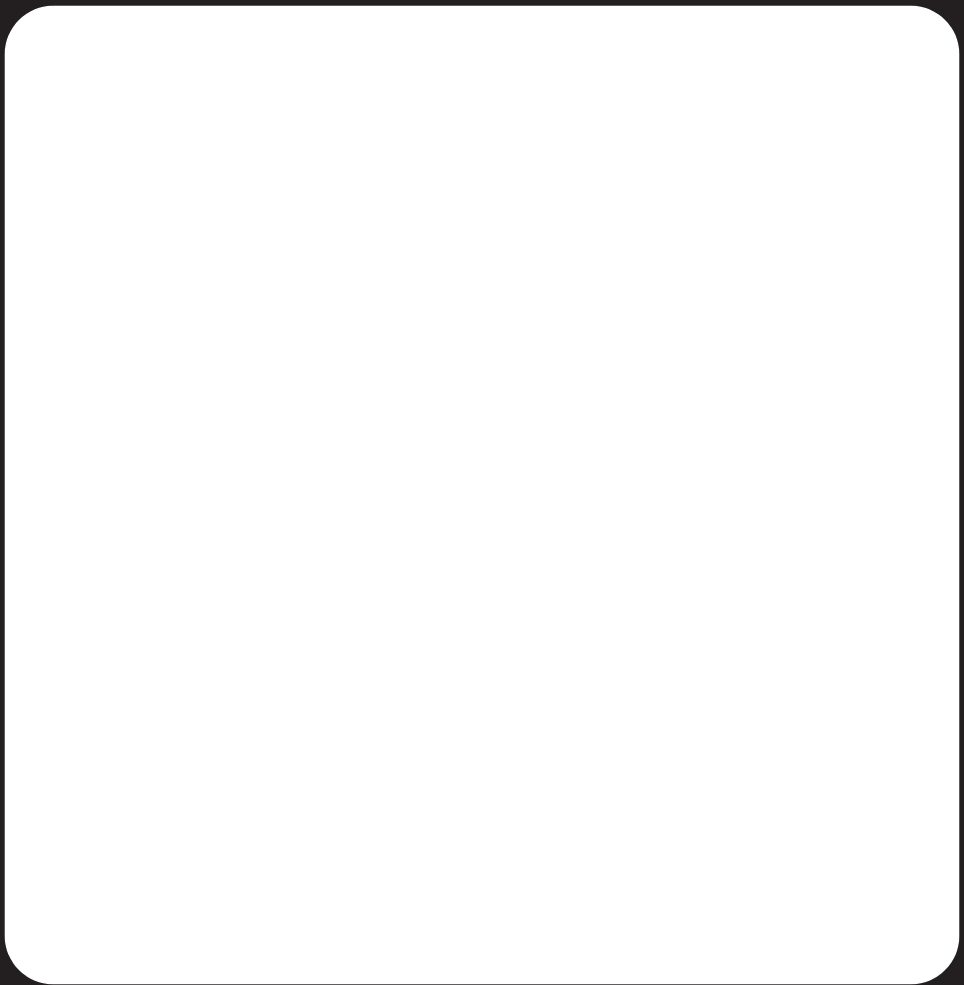

Setup Guide

About the Sonos ZoneBridge

Use a ZoneBridge to connect the Sonos Digital Music System to your home network—or if you want to set up a music zone in an area that lies beyond your current range, you can use a ZoneBridge to extend the wireless range of your Sonos Digital Music System.

Where to Begin

Already have Sonos?

If you are adding this ZoneBridge to an existing Sonos music system, you can turn directly to page 4 for installation instructions.

New to Sonos?

Unpack your Sonos components, and then simply follow the setup instructions in sequential order to ensure that you set up your Sonos® Digital Music System correctly. See "Network requirements" on page 3 to make sure your home network is ready for Sonos, and then turn to page 6 for installation instructions.

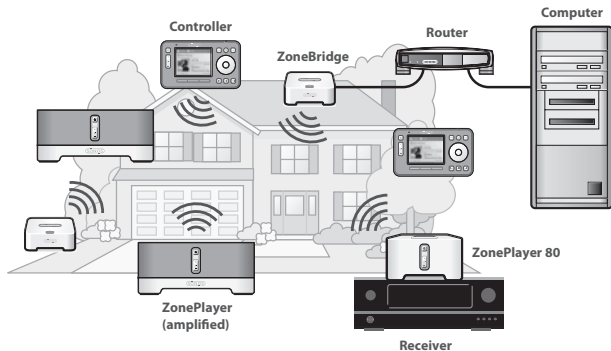

Your Computer Network



Note: Your network must have a high-speed Internet connection, as the Sonos Digital Music System is designed to provide you with online software updates. Your Sonos system must be registered in order to receive updates, so be sure to register during the setup process. We do not share your e-mail address with other companies.

To play the digital music files stored on your computer, your computer network must meet the following requirements:

Network requirements

- DSL/cable modem, or LAN-based, high-speed Internet connection.
- If you currently have a cable or DSL modem connected directly to your computer, you should install a router between your modem and your computer to enhance your computer's security, and to share the Internet connection with the Sonos Digital Music System and other devices. If you do not have a router, you should purchase and install one before proceeding.

Compatible operating systems

- Windows Vista™
- Windows® XP, including Windows® XP Media Center
- Macintosh® OS X

Please visit our Web site at <http://faq.sonos.com/specs> for the latest system requirements.

Adding To EXISTING Sonos System

If you are adding this ZoneBridge to an existing Sonos system, please follow the steps below. If you are setting up a new Sonos Digital Music System, please turn to page 6 instead.

Use a Sonos ZoneBridge to replace the ZonePlayer™ that is currently wired to your home network, or place a ZoneBridge in any location to extend the wireless range of your Sonos Digital Music System.



Important: If you are replacing the *wired* ZonePlayer in your music system with a Sonos ZoneBridge, first add the new ZoneBridge to your music system (steps below). You can then unplug the wired ZonePlayer, replace it with the Sonos ZoneBridge, and move the original ZonePlayer to a new location.

- 1** Attach the power adapter and plug in the ZoneBridge. Be sure it is the proper power adapter for your country.
If you are making a wired connection, connect a standard Ethernet cable. If you are making a wireless connection, skip this step and continue.
- 2** Insert the System Setup CD-ROM packaged with your ZoneBridge, and follow the prompts to update your Sonos system.
- 3** Choose one of the following options:
 - Use the *Desktop Controller* software to add the ZoneBridge to your music system by selecting **Add a ZonePlayer or ZoneBridge** from the **Zones** menu.

- Use the *Sonos Controller* to add the ZoneBridge to your music system by selecting **System Settings**→**Add a ZonePlayer or ZoneBridge** from the **Music** menu.

During the setup process, you will be asked to press and release the **Connect** button on top of the ZoneBridge. The indicator lights will flash green and white while the ZoneBridge is connecting.



Now that you've added the ZoneBridge to your music system—

- If you are replacing the ZonePlayer that is currently attached to your router, you can unplug the wired ZonePlayer, replace it with the Sonos ZoneBridge, and move the original ZonePlayer to a new location.
- If you are using the ZoneBridge elsewhere in your house to extend your wireless network, you can now move any of your existing ZonePlayers to other locations if desired.

Setting Up NEW Sonos System

Connect the ZoneBridge to your home network by following the steps below. (If you are going to use speakers in this music zone, you can connect a ZonePlayer 100 in step 2 instead. If you would like to utilize an external amplifier or powered speakers in this music zone, you can connect a ZonePlayer 80 in step 2 instead.)

- 1 Attach the power adapter and plug in the Sonos ZoneBridge.
- 2 Connect a standard Ethernet cable (supplied) from one of the Ethernet switch connectors on the back of your ZoneBridge to an open port on your router (see **A** in the diagram below).

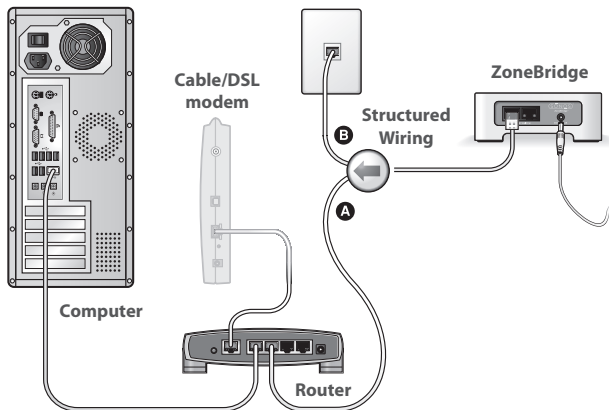

If you have structured (built-in) wiring, connect the Ethernet cable into a live wall plate (see **B** in the diagram).

Do not connect the ZoneBridge directly to your cable or DSL modem unless your modem has a built-in router.

- If you don't have a router, go to <http://faq.sonos.com/norouter> for instructions.
- If you don't have an open port on your router, you can disconnect your computer from the router and connect it to the ZoneBridge instead (see below). Then connect the ZoneBridge into the router port the computer was previously plugged into.

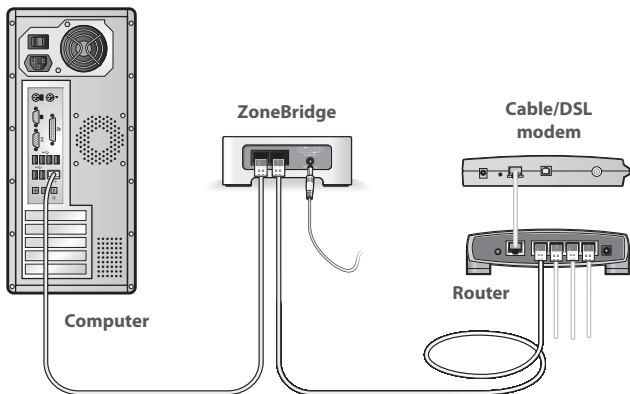

- 3 Insert the Sonos System Setup CD-ROM (be sure to use the one included with your ZoneBridge), and follow the prompts to connect the ZoneBridge and set up access to your music files. The CD-ROM will quickly and easily guide you through the setup process.



Important: When you insert the CD-ROM, you will be prompted to check for software updates. Be sure to select **Yes**, as the Sonos ZoneBridge requires the latest software release.



For use with:

- Windows Vista
- Windows XP, including Windows XP Media Center
- Macintosh OS X

Please visit our Web site at

<http://faq.sonos.com/specs> for the latest compatible operating system versions.

Now that you've set up the ZoneBridge you are ready to add the rest of your Sonos components. Turn to "Adding More Sonos Components" on page 9.

Adding More Sonos Components

Once you've set up your ZoneBridge, you can easily add more components any time. If your house has structured (built-in) wiring, you can make a *wired* connection to additional ZonePlayers or ZoneBridges. If you don't have structured wiring, our built-in wireless technology is ideal for you.



Note: Thick walls, 2.4 GHz cordless telephones, and the presence of other wireless devices can interfere with the wireless network signals from your Sonos Digital Music System. If you are experiencing difficulty, it is advisable to relocate the Sonos component, change the wireless channel your music system is operating on, or make a wired connection (Ethernet cable) either from your router to the ZoneBridge, or from one ZonePlayer to another (see page 13.) If you are having trouble placing your units within wireless range of each other, visit our Web site at <http://faq.sonos.com/range>.

Add a ZonePlayer or ZoneBridge

1. Choose one of the following options:
 - If you are adding an amplified ZonePlayer, attach desired speakers.
 - If you are adding a ZonePlayer 80, connect an external amplifier.
 - If you are adding a ZoneBridge, attach the power adapter.



Note: For detailed ZonePlayer setup instructions, refer to the ZonePlayer Setup Guide packaged with your ZonePlayer, or go to Sonos System Help, the online help system included with your Desktop Controller software.

2. If you are making a wired connection, connect a standard Ethernet cable from your router, another ZonePlayer or ZoneBridge, or a *live* network wall plate to one of the Ethernet switch connections on the back of the new Sonos component. If you are making a wireless connection, skip this step.
3. Attach the power cable (if you haven't already done so) and apply power.
4. Choose one of the following options:
 - Using the *Sonos Controller*, select **System Settings**→**Add a ZonePlayer or ZoneBridge** from the **Music** menu.
 - Using the *Desktop Controller* software, select **Add a ZonePlayer or ZoneBridge** from the **Zones** menu.

Add a Controller

You should charge your new Sonos Controller when you remove it from the packaging. Plug it into the power adapter, and then follow the Controller's on-screen prompts to add it to your music system (you can use the Controller while it is charging.)

ZoneBridge Front

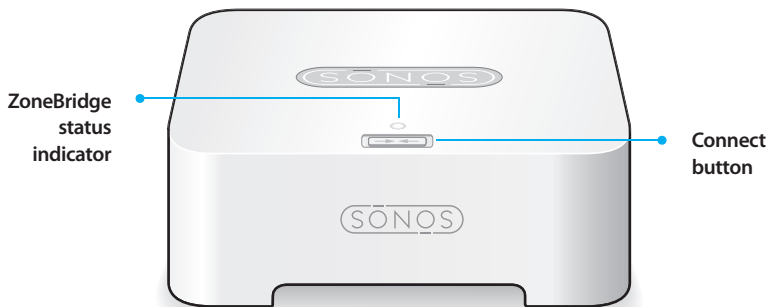

Connect button

Press the **Connect** button to join the ZoneBridge to your Sonos Digital Music System.

ZoneBridge status indicator

- LED *Flashes white* when powering up or connecting to your Sonos Digital Music System.
- LED *Solid white* when powered up and connected to your Sonos Digital Music System (normal operation).
- LED *Flashes amber* when a fault condition is detected.

ZoneBridge Rear Panel



Ethernet switch connectors (2)

Use Category 5 Ethernet cable to connect to a router, computer, or additional network device such as a network-attached storage (NAS) device.

AC power (mains) input

Use the supplied power adapter to connect to power outlet. Be sure to use the proper power adapter for your country.

Basic Troubleshooting



Important: Under no circumstances should the product be repaired by anyone other than an authorized Sonos repair center, as this will invalidate the warranty. Please contact the Sonos Customer Service Center to locate an authorized repair center in your area. Do not open the system as there is a risk of electric shock.

If a problem occurs, you can try the troubleshooting suggestions listed below. If one of these doesn't remedy the problem, or you are not sure how to proceed, please contact the Sonos Customer Service Center and we'll be happy to help.

- **Web site**

Visit our Web site at **www.sonos.com/support**. There you can visit our Forums, browse our Frequently Asked Questions (FAQ) pages, or request assistance.

- **Telephone**

Visit our Web site at **www.sonos.com/support** and click **Phone Support** to find the correct telephone number for your country.

ZoneBridge not detected during setup

Which CD-ROM did you use to install the ZoneBridge? If you did not use the CD-ROM packaged with your ZoneBridge, insert *that* CD-ROM and follow the prompts to set up your ZoneBridge.

If that is not the problem, a network issue may be preventing the ZoneBridge from joining your Sonos system. If this is a wireless ZoneBridge, try moving the ZoneBridge

closer to a ZonePlayer, or wire the ZoneBridge temporarily to see if the problem is related to wireless interference.

If you encounter this message when installing the first Sonos component, (wired to your router), you can try the steps below to resolve this issue.

1. Check the firewall

Firewall software installed on the computer may be blocking the ports that Sonos uses to operate. First, disable all your firewalls and try to connect again. If this resolves the problem, you should configure your firewall to work with the Sonos Desktop Controller. Please visit our Web site at <http://faq.sonos.com/firewall> for additional information. If this does not resolve the problem, you can try step 2 below.

2. Check the router

You can bypass your router's switch to determine whether there are any router configuration issues (note that the ZoneBridge and the computer still have Internet access in this configuration):

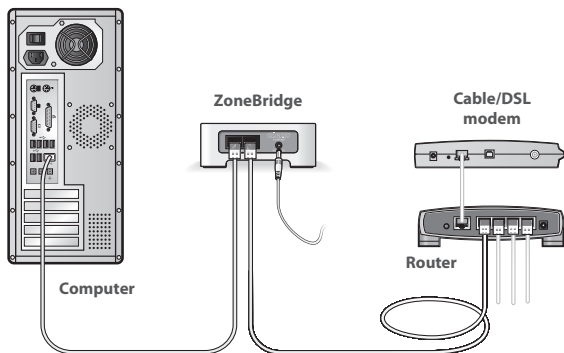

- Be sure that your cable/DSL modem is connected to the router's WAN (Internet) port.
- Temporarily remove any other components that are wired to your network.
- Connect an Ethernet cable from the computer directly to the back of the ZoneBridge, and then connect another Ethernet cable from the ZoneBridge directly to one of the LAN ports on your router.
- When you make a change to your network configuration, you may need to power cycle the ZoneBridge by unplugging the power cord, and then plugging it back in.
- If you are not using a router, visit our Web site at <http://faq.sonos.com/norouter> for more information.

If you are still experiencing problems, please contact the Sonos Customer Service Center.

Important Safety Information

1. Read these instructions.
2. Keep these instructions.
3. Heed all warnings.
4. Follow all instructions.
5. Do not use this apparatus near water.
6. Clean only with dry soft cloth. Household cleaners or solvents can damage the finish on your Sonos components.

7. Do not block any ventilation openings. Install in accordance with the manufacturer's instructions.

8. Do not install near any heat sources such as radiators, heat registers, stoves, or other apparatus that produce heat.

9. Protect the power cable from being walked on or pinched, particularly at plugs, convenience receptacles, and the point where they exit from the apparatus.

10. Only use attachments/accessories specified by the manufacturer.

11. Unplug this apparatus during lightning storms or when unused for long periods of time.

12. Refer all servicing to Sonos qualified service personnel. Servicing is required when the apparatus has been damaged in any way, such as power-supply cable or plug is damaged, liquid has been spilled or objects have fallen into the apparatus, the apparatus has been exposed to rain or moisture, does not operate normally, or has been dropped.

13. The Mains plug should be readily available to disconnect the equipment.



14. Warning: To reduce the risk of fire or electric shock, do not expose this apparatus to rain or moisture.

15. Do not expose apparatus to dripping or splashing and do not place objects filled with liquids, such as vases, on the apparatus.