

Using your camcorder abroad

Using your camcorder abroad

Countries and areas where you can use network functions are restricted. For details, refer to the separate Network Function Operating Instructions (DCR-IP220 only).

You can use your camcorder in any country or area with the AC power adaptor supplied with your camcorder within 100 V to 240 V AC, 50/60 Hz.

Use a commercially available AC plug adaptor [a], if necessary, depending on the design of the wall outlet [b].

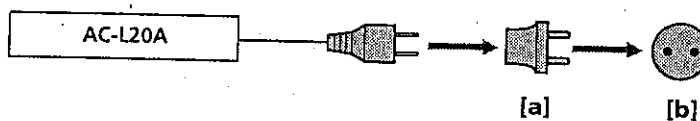

Your camcorder is an NTSC system based camcorder. If you want to view the playback picture on a TV, it must be an NTSC system based TV with VIDEO/AUDIO input jack. The following shows TV color systems used overseas.

NTSC system

Bahama Islands, Bolivia, Canada, Central America, Chile, Colombia, Ecuador, Guyana, Jamaica, Japan, Korea, Mexico, Peru, Surinam, Taiwan, the Philippines, the U.S.A., Venezuela, etc.

PAL system

Australia, Austria, Belgium, China, Czech Republic, Denmark, Finland, Germany, Holland, Hong Kong, Hungary, Italy, Kuwait, Malaysia, New Zealand, Norway, Poland, Portugal, Singapore, Slovak Republic, Spain, Sweden, Switzerland, Thailand, United Kingdom, etc.

PAL-M system

Brazil

PAL-N system

Argentina, Paraguay, Uruguay



SECAM system

Bulgaria, France, Guiana, Iran, Iraq, Monaco, Russia, Ukraine, etc.

Additional Information

Maintenance information and precautions

Moisture condensation

If your camcorder is brought directly from a cold place to a warm place, moisture may condense inside your camcorder, on the surface of the tape, or on the lens. In this condition, the tape may stick to the head drum and be damaged or your camcorder may not operate correctly. If there is moisture inside your camcorder, the beep sounds and the  indicator flashes. When the  indicator flashes at the same time, the cassette is inserted in your camcorder. If moisture condenses on the lens, the indicator will not appear.

If moisture condensation occurred

None of the functions except cassette ejection will work. Eject the cassette, turn off your camcorder, and leave it for about one hour with the cassette compartment open. Your camcorder can be used again if the  indicator does not appear when the power is turned on again.

If moisture starts to condense, your camcorder sometimes cannot detect condensation. If this happens, the cassette is sometimes not ejected for 10 seconds after the cassette lid is opened. This is not a malfunction. Do not close the cassette lid until the cassette is ejected.

Note on moisture condensation

Moisture may condense when you bring your camcorder from a cold place into a warm place (or vice versa) or when you use your camcorder in a hot place as follows:

- You bring your camcorder from a ski slope into a place warmed up by a heating device.
- You bring your camcorder from an air-conditioned car or room into a hot place outside.
- You use your camcorder after a squall or a shower.
- You use your camcorder in a high temperature and humidity place.

How to prevent moisture condensation



When you bring your camcorder from a cold place into a warm place, put your camcorder in a plastic bag and tightly seal it. Remove the bag when the air temperature inside the plastic bag has reached the surrounding temperature (after about one hour).

Maintenance information and precautions

Maintenance information

Cleaning the video head

To ensure normal recording and clear pictures, clean the video head. The video head may be dirty when:

- Mosaic-pattern noise appears on the playback picture.
- Playback pictures do not move.
- Playback pictures do not appear.
- The  indicator and "CLEANING CASSETTE" message appear one after another or the  indicator flashes on the LCD screen during recording.

If the above problem, [a] or [b] occurs, clean the video heads with the Sony MGRCLD cleaning cassette (optional). Check the picture and if the above problem persists, repeat cleaning.

[a]



[b]

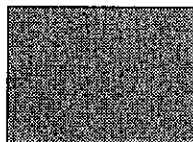

If the video heads gets dirtier, the entire screen becomes blue [b].

The video head

The video head wears out if you use the camcorder for a long time. When use of the cleaning cassette does not make the picture clear, the video head may have worn out. In such cases, you must replace the video head. For details, contact your Sony dealer or local authorized Sony service facility.

Using a cleaning cassette

Follow the procedure below.

- (1) Set the POWER switch to CAMERA or VCR.
- (2) Insert the cleaning cassette.
- (3) Press OK on the LCD screen. The message "NOW CLEANING" appears.
After the cleaning is finished, the message " CLEANING END" appears.
- (4) Eject the cleaning cassette.

To cancel cleaning

Press CANCEL.

Notes

- When cleaning the video head, do not use any equipment other than the cleaning cassette.
- The cleaning cassette does not work in MEMORY mode.

Cleaning the LCD screen

If fingerprints or dust make the LCD screen dirty, we recommend using a LCD cleaning cloth (supplied) to clean the LCD screen. When you use the LCD Cleaning Kit (optional), do not apply the cleaning liquid directly to the LCD screen. Clean the LCD screen with a cleaning paper moistened with the liquid.

Maintenance information and precautions

Charging the built-in rechargeable battery

Your camcorder is supplied with a built-in rechargeable battery installed so as to retain the date and time, etc., regardless of the setting of the POWER switch. The built-in rechargeable battery is always charged as long as you are using your camcorder. The battery, however, will get discharged gradually if you do not use your camcorder. It will be completely discharged in about three months if you do not use your camcorder at all. Even if the built-in rechargeable battery is not charged, it will not affect your camcorder operation. To retain the date and time, etc., charge the battery if the battery is discharged.

Charging the built-in rechargeable battery

- Connect your camcorder to a wall outlet using the AC power adaptor supplied with your camcorder, and leave your camcorder with the POWER switch turned off for more than 24 hours.
- Or insert the fully charged battery pack in your camcorder, and leave your camcorder with the POWER switch turned off for more than 24 hours.

Removing dust from inside the viewfinder

- (1) Remove the screw with a screwdriver (optional).
- (2) Slide the viewfinder 1.5 mm to the left and then pull it to remove the eyecup.

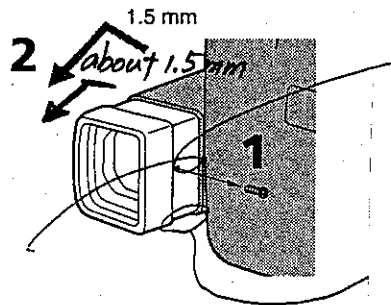

- (3) Remove dust from inside the eyecup and viewfinder with a commercially available blower.
- (4) Reverse the above steps (1) and (2) to attach the eyecup. Then replace the screw.

Caution

Do not remove any other screws. You may remove only the screw to remove the eyecup.

Notes

- Do not drop or bend the eyecup shaft.
- Be careful when handling the eyecup.

Maintenance information and precautions

Adjusting the LCD screen (CALIBRATION)

The buttons on the touch panel may not work correctly. If this happens, follow the procedure below.

- (1) Set the POWER switch to OFF (CHG).
- (2) Eject the tape from your camcorder, then disconnect any connecting cable from your camcorder.
- (3) Set the POWER switch to VCR while pressing DISPLAY/TOUCH PANEL on your camcorder, then keep pressing DISPLAY/TOUCH PANEL for about five seconds.
- (4) Follow the procedure below with your finger or the supplied stylus (DCR-IP220 only).
 - ① Touch X at the upper left corner.
 - ② Touch X at the lower right corner.
 - ③ Touch X in the middle of the LCD screen.

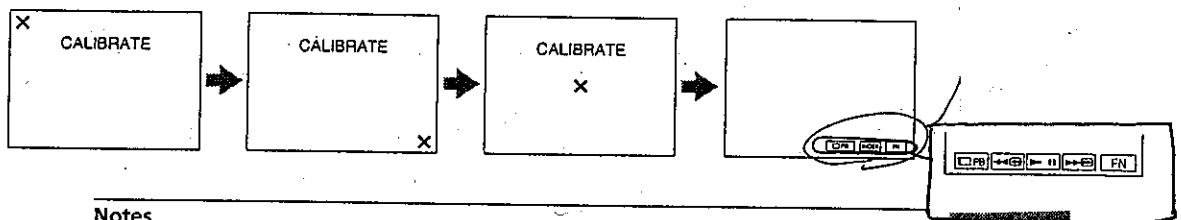

Notes

- If you do not press the right spot, X always returns to the position at the upper left corner. In this case, start from step 4 again.
- You cannot carry out this operation with the LCD panel turned back as shown below.

Additional Information

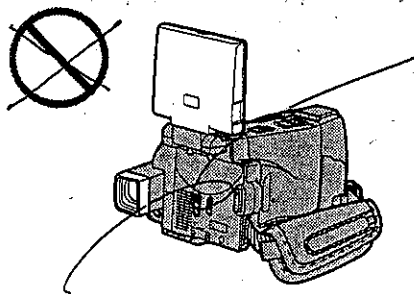

Maintenance information and precautions

Precautions

Camcorder operation

- Operate your camcorder on 7.2 V (battery pack) or 8.4 V (AC power adaptor).
- For DC or AC operation, use the accessories recommended in this operating instructions.
- If any solid object or liquid get inside the casing, unplug your camcorder and have it checked by a Sony dealer before operating it any further.
- Avoid rough handling or mechanical shock. Be particularly careful of the lens.
- Keep the POWER switch set to OFF (CHG) when you are not using your camcorder.
- Do not wrap your camcorder with a towel, for example, and operate it. Doing so might cause heat to build up inside.
- Keep your camcorder away from strong magnetic fields or mechanical vibration.
- Do not touch the LCD screen with a sharp object other than the stylus supplied (DCR-IP220 only).
- If your camcorder is used in a cold place, a residual image may appear on the LCD screen. This is not a malfunction.
- While using your camcorder, the back of the LCD screen may heat up. This is not a malfunction.
- Do not use the network function in a medical institution or in an aircraft (DCR-IP220 only).

On handling tapes

- Do not insert anything into the small holes on the rear of the cassette. These holes are used to sense the type and thickness of the tape and if the recording tab is in or out.
- Do not open the tape protect cover or touch the tape.
- Avoid touching or damaging the terminals. To remove dust, clean the terminals with a soft cloth.

Camcorder care

- Remove the tape, and periodically turn on the power, operate the CAMERA and VCR sections and play back a tape for about three minutes when your camcorder is not to be used for a long time.
- Clean the lens with a soft brush to remove dust. If there are fingerprints on the lens, remove them with a soft cloth.
- Clean your camcorder body with a dry soft cloth, or a soft cloth lightly moistened with a mild detergent solution. Do not use any type of solvent which may damage the finish.
- Do not let sand get into your camcorder. When you use your camcorder on a sandy beach or in a dusty place, protect it from the sand or dust. Sand or dust may cause your camcorder to malfunction, and sometimes this malfunction cannot be repaired.

Maintenance information and precautions

AC power adaptor

- Unplug the unit from a wall outlet when you are not using the unit for a long time.
To disconnect the power cord, pull it out by the plug. Never pull the power cord itself.
- Do not operate the unit with a damaged cord or if the unit has been dropped or damaged.
- Do not bend the power cord forcibly, or place a heavy object on it. This will damage the cord and may cause fire or electrical shock.
- Prevent metallic objects from coming into contact with the metal parts of the connecting section. If this happens, a short may occur and the unit may be damaged.
- Always keep metal contacts clean.
- Do not disassemble the unit.
- Do not apply mechanical shock or drop the unit.
- While the unit is in use, particularly during charging, keep it away from AM receivers and video equipment. AM receivers and video equipment disturb AM reception and video operation.
- The unit becomes warm during use. This is not a malfunction.
- Do not place the unit in locations that are:
 - Extremely hot or cold
 - Dusty or dirty
 - Very humid
 - Vibrating

About care and storage of the lens

- Wipe the surface of the lens clean with a soft cloth in the following instance:
 - When there are fingerprints on the lens surface
 - In hot or humid locations
 - When the lens is used in environments such as the seaside
- Store the lens in a well-ventilated location subject to little dirt or dust.

To prevent mold from occurring, periodically perform the above.
We recommend turning on and operating your camcorder about once per month to keep your camcorder in an optimum state for a long time.

Battery pack

- Use only the specified charger or video equipment with the charging function.
- To prevent an accident from a short circuit, do not allow metal objects to come into contact with the battery terminals.
- Keep the battery pack away from fire.
- Never expose the battery pack to temperatures above 60°C (140°F), such as in a car parked in the sun or under direct sunlight.
- Store the battery pack in a cool, dry place.
- Do not expose the battery pack to any mechanical shock.
- Do not disassemble nor modify the battery pack.
- Attach the battery pack to the video equipment securely.
- Charging while some capacity remains does not affect the original battery capacity.

Maintenance information and precautions

Notes on dry batteries

To avoid possible damage from battery leakage or corrosion, observe the following:

- Be sure to insert the batteries with the + - polarities matched to the + - marks.
- Dry batteries are not rechargeable.
- Do not use a combination of new and old batteries.
- Do not use different types of batteries.
- Current flows from batteries when you are not using them for a long time.
- Do not use leaking batteries.

If batteries are leaking

- Wipe off the liquid in the battery compartment carefully before replacing the batteries.
- If you touch the liquid, wash it off with water.
- If the liquid get into your eyes, wash your eyes with a lot of water and then consult a doctor.

If any problem occurs, unplug your camcorder and contact your nearest Sony dealer.

Specifications

Video camera recorder

System

Video recording system
2 rotary heads
Helical scanning system
Audio recording system
MPEG1 Audio Layer2
(Fs 48 kHz, stereo)
Video signal
NTSC color, EIA standards
Usable cassette
MICROMV cassette with the **|||||** mark printed
Tape speed
Approx. 5.66 mm/s
Recording/playback time (using cassette MGR60)
1 hour
Fastforward/rewind time (using cassette MGR60)
Approx. 1 min. and 30 seconds
Viewfinder
Electric viewfinder (color)
Image device
xx mm (1/3.6 type) CCD
(Charge Coupled Device)
Gross: Approx. 2 000 000 pixels
Effective (still):
Approx. xxxx pixels
Effective (moving):
Approx. xxxx pixels
Lens
Carl Zeiss Vario-Sonnar T*
Combined power zoom lens
Filter diameter xx mm (1 3/16 in.)
10x (Optical), 120x (Digital)
Focal length
4.5 - 45 mm (xxx - xxx in.)
When converted to a 35 mm still camera
CAMERA:
52 - 520 mm (xxx - xxx in.)
MEMORY:
39 - 390 mm (1 11/16 - 16 5/8 in.)
Color temperature
~~Auto~~, ~~HOLD~~, ~~Hold~~, ~~Indoor~~
(3 200K), ~~Outdoor~~ (5 800K)
Minimum illumination
x lx (lux) (F 1.8)
0 lx (lux) (in the NightShot mode)*
* Objects unable to be seen due to the dark can be shot with infrared lighting.

Input/Output connectors

Audio/Video input/output
10-pin connector
Input/output auto switch
Video signal: 1 Vp-p, 75 Ω (ohms), unbalanced, sync negative
Luminance signal: 1 Vp-p, 75 Ω (ohms), unbalanced
Chrominance signal: 0.286 Vp-p, 75 Ω (ohms), unbalanced
Audio signal: 327 mV, (at output impedance more than 47 k Ω (kilohms))
Input impedance with more than 47 k Ω (kilohms)
Output impedance with less than 2.2 k Ω (kilohms)
i.LINK (MICROMV Interface) input/output
4-pin connector S400
LANC jack
Stereo mini-minijack (\varnothing 2.5 mm)
USB jack
mini-AB

LCD screen

Picture
6.2 cm (2.5 type)
60 x 37 mm (2 x 1 1/2 in.)
Total dot number:
211 200 (960 x 220)

Wireless communication (DCR-IP220 only)

Communication system
Bluetooth specification Ver.1.1
Maximum communication speed^{1) 2)}
Approx. 723 kbps
Maximum output
Bluetooth specification Power Class2
Communication distance³⁾
Approx. 10 m (33 feet) (Open space, when using a Sony BTA-NW1/NW1A Modem Adaptor with Bluetooth Function)
Compatible Bluetooth profiles³⁾
Generic Access Profile
Dial-up Networking Profile
Usable frequency band
2.4 GHz band
(2.400 - 2.483 5 GHz)

¹⁾ The maximum rate defined by Bluetooth specification Ver.1.1

²⁾ Depends on obstacles between the Bluetooth devices, radio wave conditions, etc.

³⁾ Defined by Bluetooth specification for intended use between the Bluetooth devices

General

Power requirements
7.2 V (battery pack)
8.4 V (AC power adaptor)
Average power consumption (when using the battery pack)
During camera recording using LCD: xx W
Viewfinder: xx W
Operating temperature
0°C to 40°C (32°F to 104°F)
Storage temperature
-20°C to +60°C (-4°F to +140°F)
Dimensions (approx.)
xx x xx x xx mm
(xx x xx x xx in.) (w/h/d)
Mass (approx.)
xx g (xx oz)
excluding the battery pack and cassette
xx g (x lb)
including the battery pack, NP-FF70, cassette MGR60, lens cap and strap belt
Supplied accessories
See page ••.

Additional Information

Specifications

AC power adaptor

Power requirements
100 – 240 V AC, 50/60 Hz
Power consumption
23 W
Output voltage
DC OUT: 8.4 V, 1.5 A in the operating mode
Operating temperature
0°C to 40°C (32°F to 104°F)
Storage temperature
-20°C to +60°C (-4°F to +140°F)
Dimensions (approx.)
125 × 39 × 62 mm (5 × 1 9/16 × 2 1/2 in.) (w/h/d) excluding projecting parts
Mass (approx.)
280 g (9.8 oz) excluding power cord

"Memory Stick"

Memory
Flash memory
8MB: MSA-8A
Operating voltage
2.7 – 3.6 V
Power consumption
Approx. 45 mA in the operating mode.
Approx. 130 µA in the standby mode
Dimensions (approx.)
50 × 2.8 × 21.5 mm
(2 × 1/8 × 7/8 in.) (w/h/d)
Mass (approx.)
4 g (0.14 oz)

Design and specifications are subject to change without notice.

Battery pack

Maximum output voltage
DC 8.4 V
Output voltage
DC 7.2 V
Capacity
9.6 Wh (1 350 mAh)
Operating temperature
0°C to 40°C (32°F to 104°F)
Dimensions (approx.)
40.8 × 24.1 × 49.1 mm
(1 5/8 × 31/32 × 1 15/16 in.) (w/h/d)
Mass (approx.)
90 g (3.2 oz)
Type
Lithium ion

— Quick Reference —

Identifying the parts and controls

Camcorder

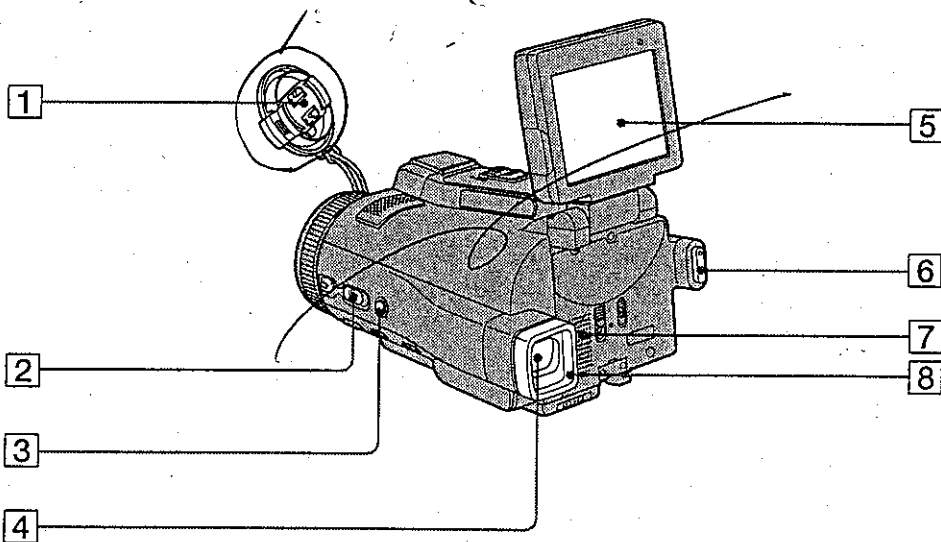

1 Lens cap (p. ••)

2 FOCUS/ZOOM switch (p. ••)

3 BACK LIGHT button (p. ••)

4 Viewfinder (p. ••)

5 LCD screen/Touch panel (p. ••, ••, ••)

6 START/STOP button (p. ••)





7 Speaker

8 Eyecup

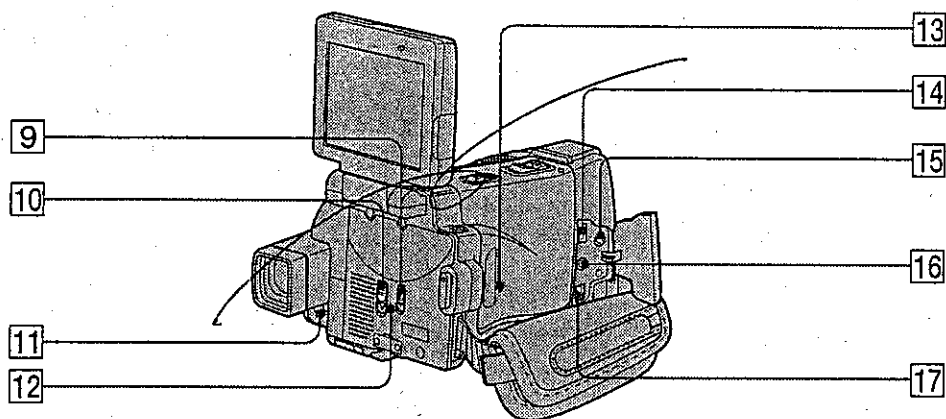
Quick Reference

Identifying the parts and controls



- 9 LCD BACKLIGHT switch (p. ••)
- 10 MEMORY EJECT switch (p. ••)
- 11 DISPLAY/TOUCH PANEL button (p. ••)
- 12 "Memory Stick" access lamp (p. ••)
- 13 RESET button 
- 14 Ψ (USB) jack (p. ••, ••, ••)
- 15  (LANC) jack
LANC stands for Local Application Control Bus System. The  control jack is used for controlling the tape transport of video equipment and other peripherals connected to the video equipment. This jack has the same function as the jack indicated as CONTROL L or REMOTE.
- 16  (headphones) jack
When you use headphones, the speaker on your camcorder is silent.
- 17 i.LINK (MICROMV Interface) (p. ••, ••, ••)
The i.LINK (MICROMV Interface) is i.LINK compatible.

Identifying the parts and controls

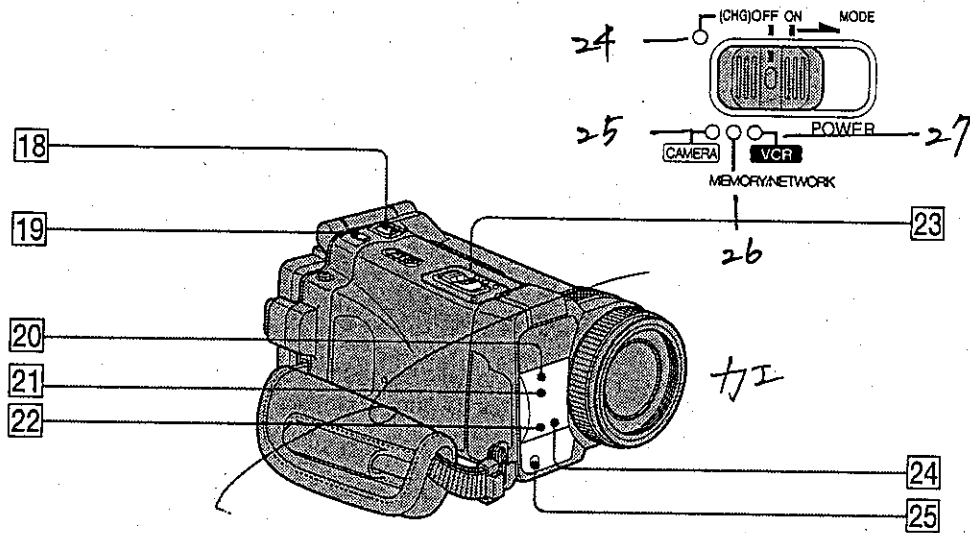

- 18 ZOOM lever (p. ●●)
- 19 PHOTO button (p. ●●, ●●)
- 20 Infrared rays (NightShot Light) emitter (p. ●●)
- 21 Remote sensor
- 22 Camera recording lamp (p. ●●)

- 23 POWER switch and lamps
 - POWER switch (p. ●●)
- 24 - (CHG) OFF lamp (p. ●●)
- 25 - CAMERA lamp (p. ●●)
- 26 - MEMORY/NETWORK lamp (DCR-IP220) or MEMORY lamp (DCR-IP210) (p. ●●)
- 27 - VCR lamp (p. ●●)
- 24 (Bluetooth) lamp (DCR-IP220 only) (p. ●●)
- 25 HOLOGRAM AF emitter (p. ●●)

Quick Reference

Identifying the parts and controls

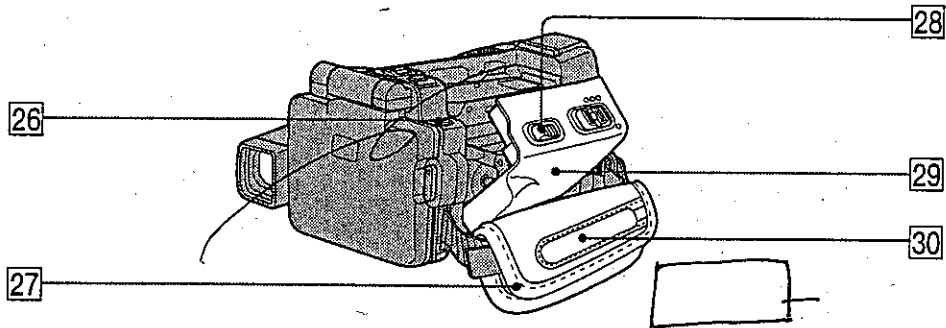

26 (flash) button (p. **, **)

27 Grip belt (p. **, **)

28 OPEN/ EJECT switch (p. **)

29 Cassette lid (p. **)

30 Stylus holder (DCR-IP220 only) (p. **)



(DCR-IP220 only) (p. **)

Fastening the grip belt
Fasten the grip strap firmly.

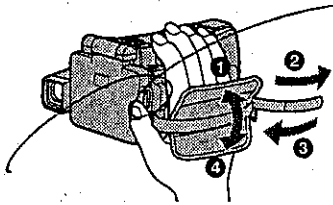

Identifying the parts and controls

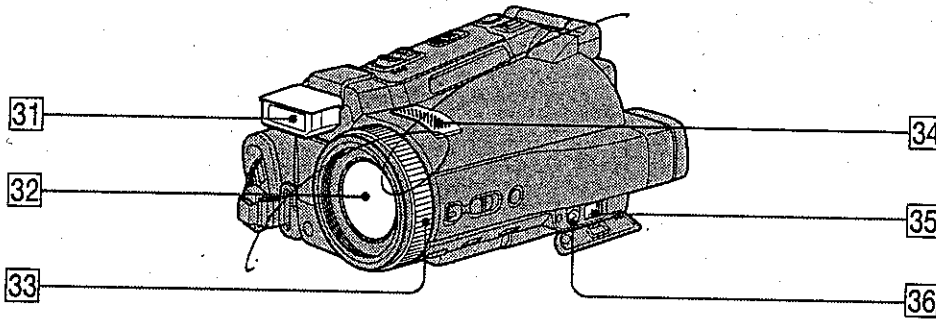

31 Flash (p. **, **)

32 Lens

33 Focus ring/Zoom ring (p. **)

34 Microphone

35 DC IN jack

36 A/V (ID-2) jack (p. **, **, **, **)

Note on the Carl Zeiss lens

Your camcorder is equipped with a Carl Zeiss lens which can reproduce a fine image.

The lens for your camcorder was developed jointly by Carl Zeiss, in Germany, and Sony Corporation. It adopts the MTF* measurement system for video camera and offers a quality as the Carl Zeiss lens.

The lens for your camcorder is also T*-coated to suppress unwanted reflection and faithfully reproduce colors.

* MTF is an abbreviation of Modulation Transfer Function.

The value number indicates the amount of light of a subject penetrating into the lens.

Quick Reference

Identifying the parts and controls

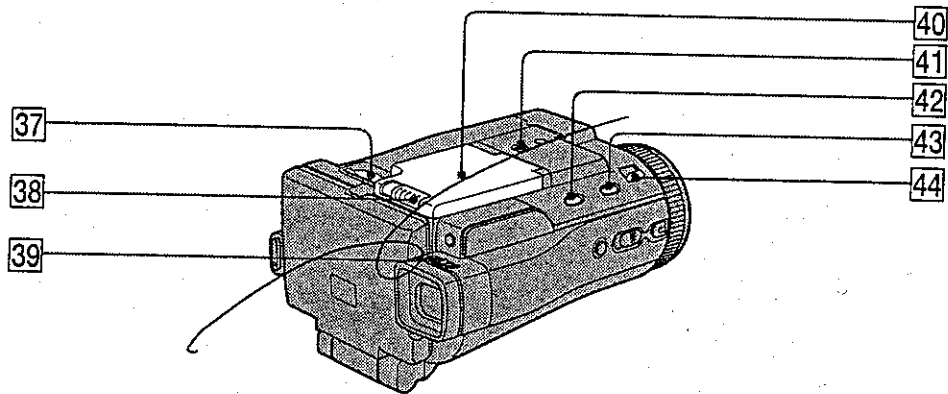

37 "Memory Stick" slot (p. ●●)

38 OPEN ∇ switch (p. ●●)

39 Viewfinder lens adjustment lever (p. ●●)

40 Battery compartment lid

41 Tripod receptacle

Make sure that the length of the tripod screw is less than 5.5 mm (7/32 inch). Otherwise, you cannot attach the tripod securely and the screw may damage your camcorder.

42 FADER button (p. ●●)

43 SUPER NS/COLOR SLOW S button (p. ●●)

44 NIGHTSHOT/NIGHTFRAMING switch (p. ●●)

Identifying the parts and controls

Remote Commander

The buttons that have the same name on the Remote Commander as on your camcorder function identically to the buttons on your camcorder.

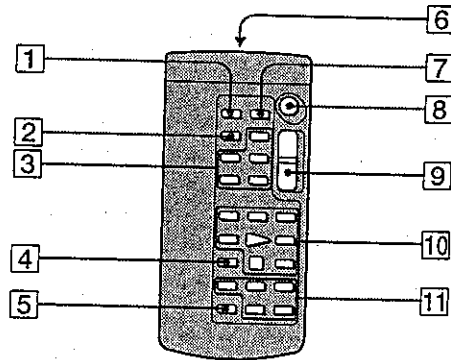

- | | |
|------------------------------------------------------------------------------------------------------------------------------------------------------------------------------------------------------------------------------------------------------------------------------------------------------------------------------------------------------------|-----------------------------------------------------------------------------------------------------------------------------------------------------------------------------------------------------------------------------------------------------------------------------------------------------------------------|
| <ul style="list-style-type: none"> 1 PHOTO button (p. ••, ••, ••) 2 DISPLAY button (p. ••) 3 MEMORY control buttons 4 SEARCH MODE button (p. •• to ••) 5 MULTI SRCH button (p. ••) 6 Transmitter
Point toward the remote sensor to control your camcorder after turning on your camcorder. | <ul style="list-style-type: none"> 7 DATA CODE button (p. ••) 8 START/STOP button (p. ••) 9 Power zoom button (p. ••) 10 Video control buttons (p. ••, ••) 11 ↑/↓/←/→/EXECUTE buttons
These buttons function the same as the control button on your camcorder. |
|------------------------------------------------------------------------------------------------------------------------------------------------------------------------------------------------------------------------------------------------------------------------------------------------------------------------------------------------------------|-----------------------------------------------------------------------------------------------------------------------------------------------------------------------------------------------------------------------------------------------------------------------------------------------------------------------|

Quick Reference

Identifying the parts and controls

To prepare the Remote Commander

Insert two size AA (R6) batteries by matching the + and - polarities on the batteries to the + - marks inside the battery compartment.

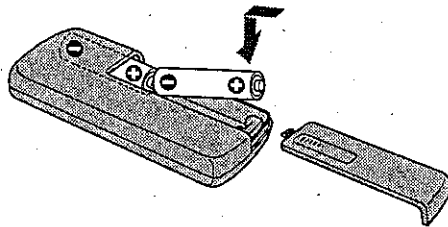

Notes on the Remote Commander

- Point the remote sensor away from strong light sources such as direct sunlight or overhead lighting. Otherwise, the Remote Commander may not function properly.
- Your camcorder works in the commander mode VTR 2. Commander modes 1, 2 and 3 are used to distinguish your camcorder from other Sony VCRs to avoid remote control misoperation. If you use another Sony VCR in the Commander mode VTR 2, we recommend changing the commander mode or covering the sensor of the VCR with black paper.

Identifying the parts and controls

Operation indicators

LCD screen and viewfinder

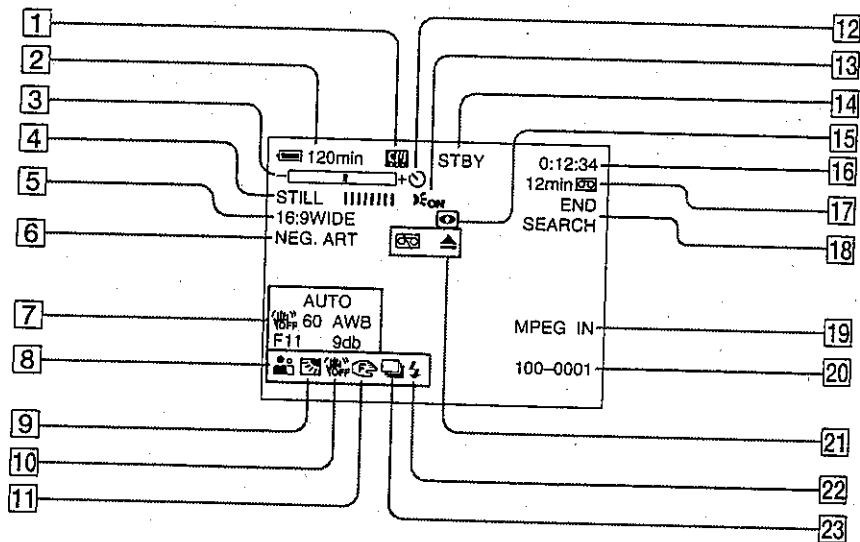

- | | |
|----------------------------------------------------------------------------------------------------------------------------------------------------------------------------------------------------------------------------------------------------------------------------------------------------------------------------------------------------------------------------------------------------------------------------------------------------------------------------------------------------------------------------------------------------------------------------------------------------------------------------------------------------------------------------------------|-----------------------------------------------------------------------------------------------------------------------------------------------------------------------------------------------------------------------------------------------------------------------------------------------------------------------------------------------------------------------------------------------------------------------------------------------------------------------------------------------------------------------------------------------------------------------------------------------------------------------------------------------------------|
| <ul style="list-style-type: none"> 1 Micro Cassette Memory (p. ●●) 2 Remaining battery time (p. ●●) 3 Zoom (p. ●●)/Data file name (p. ●●) 4 Digital effect (p. ●●)/MEMORY MIX (p. ●●)/FADER (p. ●●) 5 16:9WIDE (p. ●●) 6 Picture effect (p. ●●) 7 Data code (p. ●●)/Date (p. ●●) 8 PROGRAM AE (p. ●●) 9 BACK LIGHT (p. ●●) 10 SteadyShot off (p. ●●) 11 Manual focus (p. ●●) / EXPANDED FOCUS 12 Self-timer (p. ●●, ●●) 13 HOLOGRAM AF (p. ●●) 14 STBY/REC (p. ●●)/Video control mode (p. ●●)/Image size (p. ●●)/Image quality mode (p. ●●) | <ul style="list-style-type: none"> 15 NIGHTSHOT/SUPER NIGHTSHOT (p. ●●)/COLOR SLOW SHUTTER (p. ●●)/NIGHTFRAMING (p. ●●) 16 Tape counter (p. ●●)/Self-diagnosis (p. ●●)/Memory photo (p. ●●, ●●)/Image number (p. ●●) 17 Remaining tape (p. ●●)/Memory playback (p. ●●) 18 END SEARCH (p. ●●) 19 MPEG IN (p. ●●) 20 Data file name (p. ●●)
This indicator appears when the MEMORY MIX functions work./Time (p. ●●) 21 Warning (p. ●●) 22 Video flash ready
This indicator appears when you use the video flash light. 23 Continuous photo recording (p. ●●) |
|----------------------------------------------------------------------------------------------------------------------------------------------------------------------------------------------------------------------------------------------------------------------------------------------------------------------------------------------------------------------------------------------------------------------------------------------------------------------------------------------------------------------------------------------------------------------------------------------------------------------------------------------------------------------------------------|-----------------------------------------------------------------------------------------------------------------------------------------------------------------------------------------------------------------------------------------------------------------------------------------------------------------------------------------------------------------------------------------------------------------------------------------------------------------------------------------------------------------------------------------------------------------------------------------------------------------------------------------------------------|

Quick Reference

Index

- A, B**
- AC power adaptor
 - Adjusting viewfinder
 - Adjusting volume
 - Auto red-eye reduction... ..
 - AUTO SHTR
 - A/V connecting cable
 - BACK LIGHT
 - Battery pack
 - BEEP
 - BOUNCE
 - B & W
- C, D**
- CALIBRATION
 - Camera chroma key
 - Carl Zeiss lens
 - Cassette information
 - Cassette memory
 - Charging battery
 - Charging built-in rechargeable battery
 - Cleaning cassette
 - Clock set
 - COLOR SLOW SHUTTER
 - Continuous photo recording
 - Data code
 - DATE SEARCH
 - DEMO MODE
 - Digital effect
 - DISPLAY
 - Dubbing a tape
- E**
- END SEARCH
 - EXPANDED *FOCUS*
 - EXP BRKTG
 - Exposure
- F, G, H**
- Fader
 - Fade in/out
 - FLASH
 - FLASH MOTION
 - Flexible Spot Meter
 - FOCUS
 - Focusing manually
- FORMAT**
- Full charge
- Heads
- HIGH SPEED
- HOLOGRAM AF
- I, J, K, L**
- iLINK (MICROMV Interface)
- Image protection
- Image quality mode
- Image size
- Index screen
- "InfoLITHIUM" battery
- Infrared rays emitter
- JPEG
- Labeling a cassette
- Ⓛ (LANC) jack
- LUMINANCE KEY
- M, N**
- Manual focus
 - Memory chroma key
 - Memory luminance key
 - MEMORY MIX
 - Memory overlap
 - Memory PB ZOOM
 - Memory photo playback
 - Memory photo recording
 - "Memory Stick"
 - Menu settings
 - Micro cassette memory
 - Mirror mode
 - Moisture condensation
 - MONOTONE
 - MOSAIC
 - MOSC. FADER
 - MPEG
 - MULTI-PICTURE SEARCH
 - NEG. ART
 - MULTI SCRN
 - NETWORK
 - NIGHTSHOT
 - NIGHTFRAMING
 - NORM. FADER
 - NTSC system
- O, P, Q**
- OLD MOVIE
- Operation indicators
- PASTEL
- PB ZOOM
- Picture effect
- Playback pause
- Playing time
- Power zoom
- Print mark
- PROGRAM AE
- R**
- Recording time
 - Remaining battery time indicator
 - Remaining tape indicator
 - Remote Commander
 - Remote sensor
 - RESET
- S**
- Self-diagnosis display
 - Self-timer recording
 - SEPIA
 - Slide show
 - SLOW SHUTTER
 - SOLARIZE
 - SPOT FOCUS
 - STEADYSHOT
 - STILL
 - Stylus
 - SUPER NIGHTSHOT
 - S VIDEO jack
- T, U, V**
- Tape counter
 - Tape PB ZOOM
 - Telephoto
 - Title
 - TITLE SEARCH
 - Touch panel
 - TRAIL
 - Transition
 - TV color systems
 - USB jack
 - USB streaming
- W, X, Y, Z**
- Warning indicators
 - White balance
 - Wide-angle
 - Wide mode
 - Write-protect tab
 - Zoom

Printed on recycled paper.
 Printed using VOC (Volatile Organic
 Compound)-free vegetable oil based ink.

<http://www.sony.net/>

Sony Corporation Printed in Japan

