

Digital Audio Nursery Monitor

Operating Instructions

[TENTATIVE]

©2013 Sony Corporation Printed in China



NTM-DA1

http://www.sony.net/

SONY Portable Audio

LIMITED WARRANTY (U.S. Only)

Sony Electronics Inc. ("Sony") warrants this product against defects in material or workmanship for the time periods and as set forth below when purchased directly from Sony or a Sony Retailer. Pursuant to this Limited Warranty, Sony will, at its option, (i) repair the product using new or refurbished parts or (ii) replace the product with a new or refurbished product. For purposes of this Limited Warranty, "refurbished" means a product or part that has been returned to its original specifications. **In the event of a defect, these are your exclusive remedies.**

Term: For a period of one (1) year from the original date of purchase of the product, Sony will, at its option, repair or replace with new or refurbished product or parts, any product or parts determined to be defective.

This Limited Warranty covers only the hardware components packaged with the Product. It does not cover technical assistance for hardware or software usage and it does not cover any software products whether or not contained in the Product; any such software is provided "AS IS" unless expressly provided for in any enclosed software Limited Warranty. Please refer to the End User License Agreements included with the Product for your rights and obligations with respect to the software.

Instructions: To obtain warranty service, you must deliver the product, freight prepaid, in either its original packaging or packaging affording an equal degree of protection to the Sony authorized service facility specified. **It is your responsibility to backup any data, software or other materials you may have stored or preserved on your unit. It is likely that such data, software, or other materials will be lost or reformatted during service and Sony will not be responsible for any such damage or loss.** A dated purchase receipt from Sony or a Sony Retailer is required. For specific instructions on how to obtain warranty service for your product.

The Address of the Laredo Fulfillment Center is:

Laredo Fulfillment Center
10227 Crossroads Loop Suite B
Laredo, TX 78045

Visit Sony's Web Site:
www.sony.com/support

Or call the **Sony Customer Information Service Center**
1-800-222-SONY (7669)

For an accessory or part not available from your authorized dealer, call:
1-800-488-SONY (7669)

Repair / Replacement Warranty: This Limited Warranty shall apply to any repair, replacement part or replacement product for the remainder of the original Limited Warranty period or for ninety (90) days, whichever is longer. Any parts or product replaced under this Limited Warranty will become the property of Sony.

This Limited Warranty only covers product issues caused by defects in material or workmanship during ordinary consumer use; it does not cover product issues caused by any other reason, including but not limited to product issues due to commercial use, acts of God, misuse, limitations of technology, or modification of or to any part of the Sony product or product purchased from other than Sony or a Sony Retailer. To determine if a retailer is part of the Sony Retailer Network, please contact Sony's Customer Service Call Center or go to www.sony.com/support. This Limited Warranty does not cover Sony products sold AS IS or WITH ALL FAULTS or consumables (such as fuses or batteries). This Limited Warranty is invalid if the factory-applied serial number has been altered or removed from the product. This Limited Warranty is valid only in the United States.

LIMITATION ON DAMAGES: SONY SHALL NOT BE LIABLE FOR ANY INCIDENTAL OR CONSEQUENTIAL DAMAGES FOR BREACH OF ANY EXPRESS OR IMPLIED WARRANTY ON THIS PRODUCT.

DURATION OF IMPLIED WARRANTIES: EXCEPT TO THE EXTENT PROHIBITED BY APPLICABLE LAW, ANY IMPLIED WARRANTY OF MERCHANTABILITY OR FITNESS FOR A PARTICULAR PURPOSE ON THIS PRODUCT IS LIMITED IN DURATION TO THE DURATION OF THIS WARRANTY.

Some states do not allow the exclusion or limitation of incidental or consequential damages, or allow limitations on how long an implied warranty lasts, so the above limitations or exclusions may not apply to you. This Limited Warranty gives you specific legal rights and you may have other rights which vary from state to state.

Owner's Record

The model and serial numbers are located on the rear of the receiver (under the belt clip). Record the serial number in the space provided below. Refer to these numbers whenever you call upon your Sony dealer regarding this product.

Model No. NTM-DA1
Serial No. _____

Model No. AC-P5004
Serial No. _____

For customers who purchased this product in the USA
Please register this product on line at <http://www.sony.com/productregistration>. Proper registration will enable us to send you periodic mailings about new products, services, and other important announcements. Registering your product will also allow us to contact you in the unlikely event that the product needs adjustment or modification. Thank you.

⚠ WARNING

To reduce fire or shock hazard, do not expose the unit to rain or moisture.

IMPORTANT SAFETY INSTRUCTIONS

-SAVE THESE INSTRUCTIONS
DANGER
TO REDUCE THE RISK OF FIRE OR ELECTRIC SHOCK, CAREFULLY FOLLOW THESE INSTRUCTIONS

If the shape of the plug does not fit the power outlet, use an attachment plug adaptor of the proper configuration for the power outlet.

STRANGULATION HAZARD

Children have STRANGLED in cords. Keep the cord out of the reach of children (more than 0.9 m (3 ft) away). Do not remove the tag on the cord.

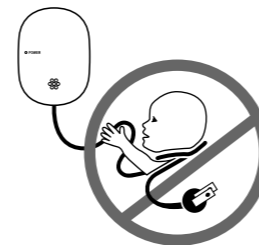

To prevent cord entanglement and strangulation:

- Do not place the transmitter or AC adaptor cord within reach of children.
- Do not place the transmitter or AC adaptor cord in, or attach it to, a crib or playpen.
- Fasten the AC adaptor cord of the transmitter on the wall with cord clips (not supplied).
- Never use extension cords with AC adaptors. Use only AC adaptors provided.

This device complies with Part 15 of the FCC Rules. Operation is subject to the following two conditions:
(1) this device may not cause harmful interference, and
(2) this device must accept any interference received, including interference that may cause undesired operation.

CAUTION

Observe the following cautions, as there may be a risk of heat generation, fire or explosion.
* Nickel Metal Hydride battery is built into the product.

- Charge the product by the designated charging method.
- Do not place the product in or near fire, or put the product in a microwave.
- Do not leave the product in a car in hot weather.
- Do not store or use the product in a hot and humid place such as in a sauna bath.
- Do not disassemble, crush or pierce the product.
- Do not expose the product to excessive shock such as dropping from a high place.
- Do not expose the product to high temperatures above 60 °C (140 °F).
- Keep the product dry.

Dispose of the product appropriately.
Charge the product by the designated charging method in the instruction manual.

CAUTION
You are cautioned that any changes or modifications not expressly approved in this manual could void your authority to operate this equipment.

For the customers in the U.S.A.

Note:
This equipment has been tested and found to comply with the limits for a Class B digital device, pursuant to Part 15 of the FCC Rules. These limits are designed to provide reasonable protection against harmful interference in a residential installation. This equipment generates, uses, and can radiate radio frequency energy and, if not installed and used in accordance with the instructions, may cause harmful interference to radio communications. However, there is no guarantee that interference will not occur in a particular installation. If this equipment does cause harmful interference to radio or television reception, which can be determined by turning the equipment off and on, the user is encouraged to try to correct the interference by one or more of the following measures:

- Reorient or relocate the receiving antenna.
- Increase the separation between the equipment and receiver.
- Connect the equipment into an outlet on a circuit different from that to which the receiver is connected.
- Consult the dealer or an experienced radio/TV technician for help.

This Transmitter must not be co-located or operated in conjunction with any other antenna or transmitter.

The following FCC statement applies only to the version of this model manufactured for sale in the USA. Other versions may not comply with FCC technical regulations.

The available scientific evidence does not show that any health problems are associated with using low power wireless devices. There is no proof, however, that these low power wireless devices are absolutely safe. Low power Wireless devices emit low levels of radio frequency energy (RF) in the microwave range while being used. Whereas high levels of RF can produce health effects (by heating tissue), exposure of low-level RF that does not produce heating effects causes no known adverse health effects. Many studies of low-level RF exposures have not found any biological effects. Some studies have suggested that some biological effects might occur, but such findings have not been confirmed by additional research. NTM-DA1 has been tested and found to comply with FCC radiation exposure limits set forth for an uncontrolled environment and meets the FCC radio frequency (RF) Exposure Guidelines in Supplement C to OET65.

Precautions

Safety Precautions

- Operate the transmitter and receiver on 5 V DC. To operate them from house current, use only the supplied AC adaptors; do not use any other type.
- Place the transmitter more than 0.9 m (3 ft) away from your child.
- Should any solid object or liquid fall into the unit, disconnect the AC adaptor after turning the unit is power off and have the unit checked by qualified personnel before operating it any further.

Notes on the AC adaptor

- Connect the AC adaptor to a nearby easily accessible wall outlet. If trouble occurs while the adaptor is in use, immediately set the Power/VOICE ACT switch of the receiver to OFF and disconnect the AC adaptor from the wall outlet. And also set the Power switch of the transmitter to OFF and disconnect the AC adaptor from the wall outlet.
- The unit is not disconnected from the AC power source (mains) as long as it is connected to the wall outlet, even if the unit itself has been turned off.
- If you are not going to use the Digital Audio Nursery Monitor for a long time, disconnect both the transmitter and receiver from the wall outlet by pulling out the AC adaptors.

If you have any questions or problems concerning your Digital Audio Nursery Monitor, please consult your nearest Sony dealer.

Precautions on Usage

This product cannot replace responsible adult supervision of a child. It is designed to assist adults in child supervision. Do not use it for medical monitoring of a sick baby or child.

- The transmitter detects normal sound levels within a range of 2 to 3 m (6 to 10 feet) from your child. If the child moves outside of this range, it may not be able to detect sounds from him or her.
- The transmission range between the transmitter and receiver is up to 270 m (900 feet) (Line of Sight). It is essential that you check the transmission range and condition of the Digital Audio Nursery Monitor on initial installation, and on a regular basis after that.
- Stay close to the receiver in order to hear normal sounds from it. Check the volume regularly to ensure that it is set high enough.
- The sensitivity of the Digital Audio Nursery Monitor can be affected by other devices using 2.4 GHz frequency, such as a wireless LAN device, a cordless telephone, or a microwave oven, that may be used near the transmitter and receiver. Using such devices may shorten the transmission range and cause sounds to be distorted.
- Avoid placing the transmitter and receiver near heat sources or where they are subject to direct sunlight, excessive dust, moisture, or mechanical shock.

Cautions on Water-resistance (for the receiver only)

The receiver is designed so that it can be used with slight exposure to water, rain, snow and other forms of moisture, but there are several points on which caution should be observed.

- Do not allow the receiver to come into contact with large amounts of water.
- Do not immerse the receiver in water. If the receiver is dropped into water, set the Power/VOICE ACT switch to OFF immediately and disconnect the power cord. Do not use it any more and consult your nearest Sony dealer.
- If the receiver get wet, wipe it off with a dry cloth.
- Do not pour cold or hot water directly from a faucet or hose onto the product, as it is not of waterproof.
- If you use the product near water, close the waterproof cover of the DC IN 5V jack firmly. If it is left open, moisture may get inside the product and may cause a malfunction.
- If moisture has gotten inside the product, some may remain in its openings. Shake the product lightly to shed water then wipe the surface. If not, the remaining water will spill out when you move the product.

Specifications

Frequency: Digital 2.4 GHz
Transmitting Distance: Approx. 270 m (900 feet) (Line of Sight)

Transmitter
Power requirement: AC adaptor (DC IN 5 V jack): 100 V-240 V AC, 50 Hz/60 Hz
Dimensions:
Normal position
Approx. 53 mm × 62.3 mm × 56.1 mm (w/h/d)
(2 1/8 in. × 2 1/2 in. × 2 1/4 in.) incl. projecting parts
When mounting on the wall
Approx. 53 mm × 45.1 mm × 70.3 mm (w/h/d)
(2 1/8 in. × 1 13/16 in. × 2 7/8 in.) incl. projecting parts
Mass: Approx. 41 g (1.45 oz)
Power consumption:
At the maximum load: ## W (IR LED On)
Normal mode: ## W (IR LED Off)

Receiver
Power requirement: AC adaptor (DC IN 5 V jack): 100 V-240 V AC, 50 Hz/60 Hz
Audio power output:
0.65 W
Speaker: 28 mm dia., 8 Ω
Dimensions:
When the stand is closed
Approx. 51.1 mm × 99.1 mm × 36.1 mm (w/h/d)
(2 1/8 in. × 4 in. × 1 7/16 in.) incl. projecting parts
When the stand is open
Approx. 51.1 mm × 97.7 mm × 69.5 mm (w/h/d)
(2 1/8 in. × 3 7/8 in. × 2 3/4 in.) incl. projecting parts
Mass: Approx. 100 g (3.53 oz)
Operating temperature: 0 °C - 40 °C (32 °F - 104 °F)
Power consumption:
At the maximum load: ## W
Normal mode *: ## W
* When operated with the medium volume level, and Voice Activation off

AC adaptor:
Input: 100 V - 240 V AC, 50 Hz/60 Hz, 0.3 A
Output: DC 5 V/0.4 A
Dimensions:
Approx. 63mm × 26.8mm × 44mm (w/h/d)
(2 1/2 in. × 1 1/16 in. × 1 3/4 in.) excl. projecting parts
Mass: Approx. 71 g (2.5 oz)

Design and specifications are subject to change without notice.

Installation

Transmitter

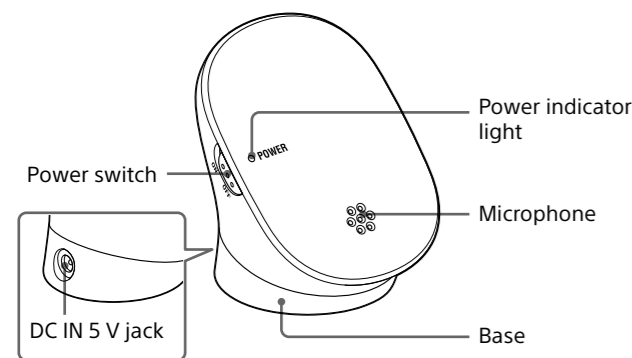

Receiver

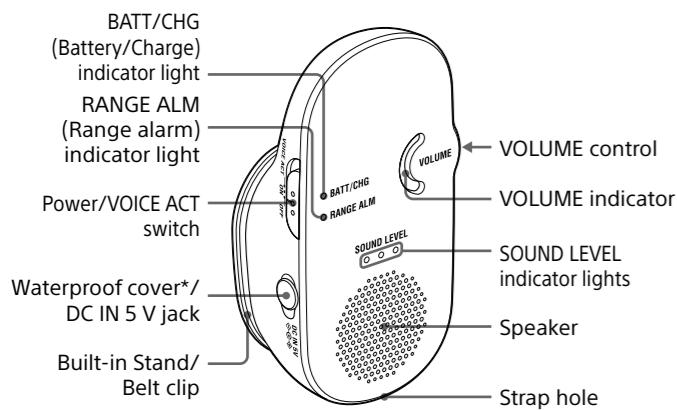

* If you use the product near water, close the waterproof cover of the DC IN 5V jack firmly. If it is left open, moisture may get inside the product and may cause a malfunction.

Indicator information (Receiver only)

BATT/CHG indicator light	Off: power off/ Green: power on/ Orange: charging/ Flashing in red: low battery
RANGE ALM indicator light	Red: indicates the receiver has been moved out of the reception range.
SOUND LEVEL indicator lights	Red: indicates the input sound volume level from the transmitter (off [low] to 3 [high]).

In the box

Transmitter (1)
Receiver (1)
AC adaptors (2)

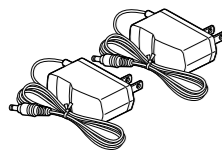

Operating Instructions (this sheet)

Tip

• The same AC adaptor is supplied for the transmitter and the receiver.

Transmitter

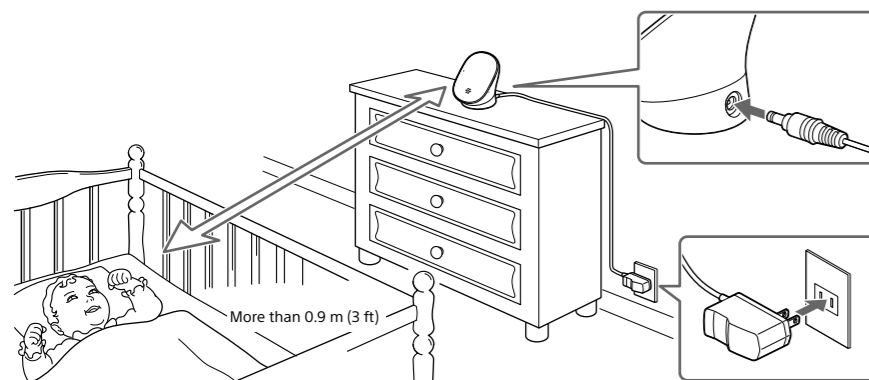

Place the transmitter more than 0.9 m (3 feet) away from your child.

1 Connect the supplied AC adaptor to the DC IN 5 V jack and plug it into a wall outlet.

Notes

- The transmitter clicks when it is turned to the maximum angle. Do not try to turn it any further.
- Do not place the transmitter or the AC adaptor cord within reach of children.
- Do not place the transmitter or the AC adaptor cord in, or attach it to, a crib or playpen.
- Never use extension cords with the AC adaptor. Use only the AC adaptor provided.
- Make sure that the transmitter is not covered or obstructed in picking up sounds.

Mounting the transmitter on a wall

A screw is not supplied. Prepare commercially available screw (diameter: 3.1 mm to 3.5 mm (1/8 in. to 9/64 in.), length: more than 20 mm (25/32 in.)) suitable for the mounting hole at the bottom of the transmitter.

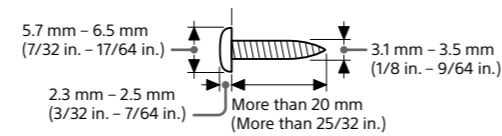

1 Screw the screw into the wall.

Be sure the screw protrude between 2.5 mm and 3 mm (1/8 in.) from the surface of the wall.

2 Hold the transmitter and turn it until it clicks.

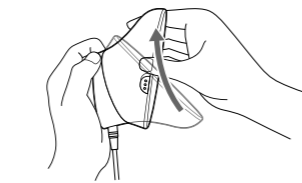

3 Mount the transmitter on the screw.

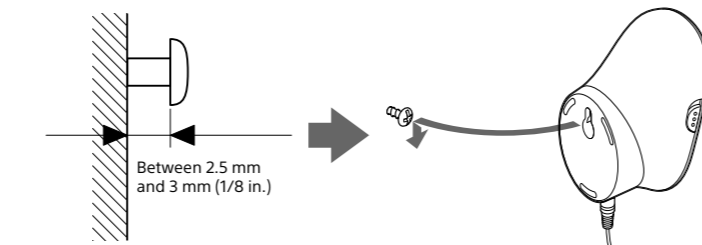

CAUTION

- The transmitter clicks when it is turned to the maximum angle. Do not try to turn it any further.
- When mounting the transmitter on a wall, use the screw suitable to the wall material or strength. Attaching screw may damage the wall. Attach the screw firmly to a pillar or a stud in a wall, if possible.
- Connect the AC adaptor cord to the transmitter, mount the transmitter on the wall, then connect the AC adaptor to a wall outlet.
- Sony is not responsible for accidents or damage caused by improper installation, insufficient wall strength or improper screw installation, natural calamity, etc.
- Fasten the screw securely so that the transmitter does not fall off the wall.

Receiver (when using it with the AC adaptor)

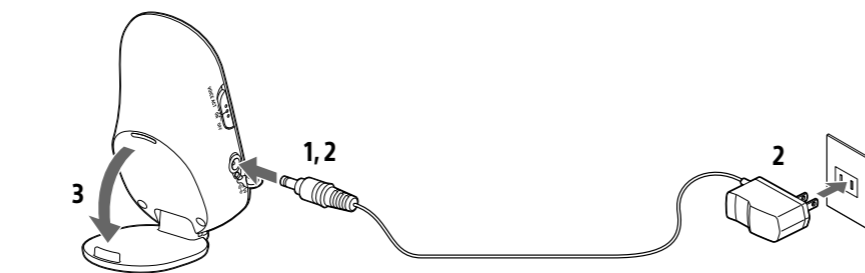

1 Open the waterproof cover of the DC IN 5V jack.

2 Connect the supplied AC adaptor to the DC IN 5 V jack and plug it into a wall outlet.

3 Open the stand, and adjust the receiver angle.

Notes

- Place the receiver on a stable surface. If the receiver is placed on an unstable surface or in an inclined position, it may fall or topple over, and may cause injury.
- Adjust the receiver angle until it is stable. If you incline the receiver too much, the it may topple over.

Carrying the receiver

When you carry the receiver by hanging it on your neck or attaching it to your belt, the receiver operates on the built-in battery. The BATT/CHG indicator light will show the remaining battery power.

Attaching a strap to the receiver

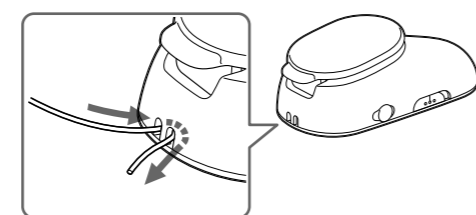

Note

- No strap is supplied. Use a strap of sufficient strength.

Attaching the receiver to your belt

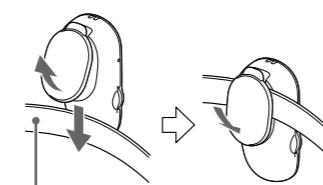

Note

- If you attach the receiver to your belt using the belt clip, handle it carefully to avoid dropping it.

Built-in battery (Receiver only)

When the receiver is connected to the AC adaptor and the built-in battery has discharged to a certain level, the built-in battery starts charging automatically and is charged up to full charge.

Battery life

It will last about 20 hours after it has been fully charged (when operated with the medium volume level, and Voice Activation off).

Charging duration

About 9 hours are required to charge the empty battery to its full capacity, in an ambient temperature of 25 °C (77 °F). Charging may take longer, depending on whether or not the receiver is turned on and other ambient conditions.

Checking the remaining battery power

When the battery power is getting low, a beep sounds and BATT/CHG indicator light of the receiver flashes red.

Notes

- If you consume the battery power completely and leave it like that, the battery life may be affected. Charge the battery by connecting it to the AC adaptor as soon as it has been used up.
- Even if you do not intend to use the receiver for a long period, charge the battery to its full capacity once every 6 months to maintain its performance.

Setting up

Turning on the power

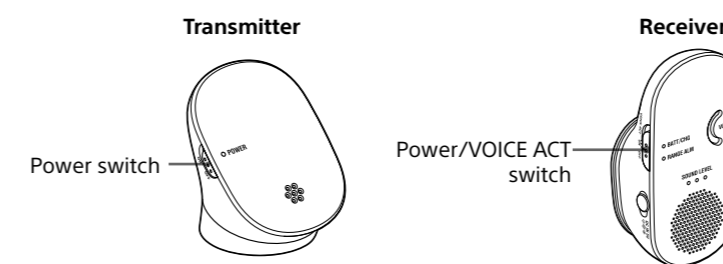

1 Set the power switch of the transmitter to ON.

2 Set the power/VOICE ACT switch of the receiver to ON or VOICE ACT. You will hear sound from the speaker.

Notes

- When the receiver is turned on while the transmitter is not on, an alarm sounds in the receiver as no signal can be transmitted. We recommend turning the transmitter on first.
- Do not turn the power on when the receiver is close to the transmitter. Feedback noise will be generated.

Tips

- According to the level of sound detected by the microphone of the transmitter, more SOUND LEVEL indicator lights (up to 3 lights) turn on in red.
- The receiver sounds an alarm when it is moved out of the transmission range.

Turning off the power

1 Set the power/VOICE ACT switch of the receiver to OFF.

2 Set the power switch of the transmitter to OFF.

Customizing the Digital Audio Nursery Monitor

Adjusting the volume

The volume of the sounds you receive varies depending on the loudness of the baby's voice, distance between the transmitter and the baby, direction of the built-in microphone of the transmitter, obstructions, etc.

Set the volume as required using the VOLUME control. If the volume level is set too high and is accompanied by a shrill noise, reduce the volume.

To increase sound volume, turn the VOLUME control downward. The green area of the VOLUME indicator is extended.

To decrease sound volume, turn the VOLUME control upward. The green area of the VOLUME indicator is reduced.

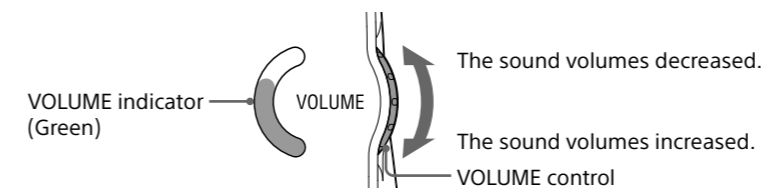

Note

- The SOUND LEVEL indicator lights turn on according to the input sound level received from the transmitter. The level setting of the VOLUME control does not affect it.

Using the Voice Activation function

The VOICE Activation function eliminates most background noise when the receiver does not detect any sound.

This function is usable when it is not required for the receiver to constantly check for sounds from the nursery, such as when the baby is sleeping quietly or the parents are sleeping.

1 Set the power/VOICE ACT switch to VOICE ACT to turn the function on.

The SOUND LEVEL indicator lights on the receiver turn on according to the sound level from the transmitter (0 [low] to 3 [high] indicators from the left).

Tips

- If no sound is detected, no SOUND LEVEL indicator lights turn on. If the sound is very loud, all 3 indicator lights turn on.
- You can also hear sound from the speaker.

Troubleshooting

Should any problem persist after you have made the following checks, consult your nearest Sony dealer. For checking or repairing the Digital Audio Nursery Monitor, the Sony dealer must have your transmitter and receiver together, even if only one of them seems to have a problem.

No sound

- The AC adaptor is disconnected from the wall outlet.
- The battery of the receiver is used up.
- The receiver is too far from the transmitter.
- Volume is low. (The volume is turned down.)
- In quiet surroundings, the power/VOICE ACT switch of the receiver is set to the VOICE ACT position.

Too much noise

- The receiver is too far from the transmitter.
- Interference from another device (microwave oven, Wi-Fi device, Bluetooth device, etc.) using 2.4 GHz frequency.
- ➔ Turn off the device, or move it further from the transmitter and receiver.

Weak reception

- The transmitting distance of the radio is 270 m (900 ft) in the line of sight, however, it may be shortened by obstructions between the transmitter and the receiver, such as walls or furniture.
- ➔ Change the location of the transmitter and receiver so that they are close to each other.

Feedback noise

- The receiver is too close to the transmitter.
- Volume is too high.

The alarm sounds

- The transmitter is not turned on.
- The receiver is too far from the transmitter.
- There is an obstruction between the transmitter and the receiver.
- The battery charge is getting low.

Warning alarm

The receiver sounds the warning alarm in the following cases. Take appropriate action, according to the alarm.

■ When the receiver is moved out of the reception range:

- The receiver sounds 4 beeps per second consecutively.
- The RANGE ALM indicator light turns in red.
- ➔ Move the receiver closer to the transmitter.

■ When the power of the built-in battery of the receiver is running out:

- If the battery power is getting low, the receiver sounds 3 beeps per second 3 times. If you continue using the receiver, the receiver sounds a beep for several seconds then turns off automatically.
- ➔ Connect the receiver to the AC adaptor.

When the problem indicated by the alarm is corrected, the alarm stops automatically. If you want to turn off the alarm, set the power/VOICE ACT switch to OFF to turn off the receiver.

Notes

- You cannot adjust the alarm volume.
- There is no setting allowing you to disable the alarm function.

[TENTATIVE]