

**SONY®**



**Reader**  
Daily Edition™

**Click for instant access!**

*Table of Contents*

*Index*

**User Guide V1.0**  
**PRS-950**  
Digital Book Reader

# CONGRATULATIONS

Your Reader Daily Edition™ comes with these useful features:

- **Unplug and unwind** – with mobile network and Wi-Fi connection, you can download ebooks straight to your Reader™ without a computer and take your library on the go.
- **7" e-paper with Clear Touch Screen** – with on a high quality screen, all you need is a soft touch by swiping to turn pages, tap to bookmark, take notes and highlight.
- **Font Zoom** – increase or decrease the text size to your preference, or zoom into images to take a closer look.
- **Dictionary and Wikipedia** – simply double-tap a word to see its definition or learn more from Wikipedia's website.

Read on. There's so much more.

- Personalize the standby screen with your favorite picture.
- Use the "Collections" feature to organize your library on your Reader to find the book you want to read.

For more details, please refer to this User Guide.

# Support

## Support for the Reader

First, check “Troubleshooting” (☰ [96](#)) and refer to the Reader Library™ Help to resolve the issue.

### Support Web site and contact:

[www.sony.com/readersupport](http://www.sony.com/readersupport)

Phone number: 1-866-962-7669

## Support for the Reader™ Store

Go to the Reader Store Help and Support page according to the followings.

Tap 📄 [Store] at [Home] menu ➔ press OPTIONS ➔ tap [Help and Support].

For details about the Reader Store, see ☰ [xx](#).

# About the User Guide

When using your Reader to view this User Guide, please note the following instructions.

## To use the page links

Tap the page link to jump to the page directly (e.g.,  [5](#)). To return to the previous page, press **OPTIONS** → tap **[Go to]** → **[Previous View]**.

## To enlarge a page

See “Zooming in” ( [49](#)).

Screen shots in this manual may be different from the actual display in the Reader.

## To use the link icons

Tap one of icons located at the bottom of the page to view either “Table of Contents” or “Index”.

# Useful Features

## Annotation

- Bookmarking (☞ [39](#))
- Highlighting Word(s) (☞ [40](#))
- Handwriting a note (☞ [41](#))
- Adding a note (☞ [42](#))

## Resizing

- Adjusting the text size (☞ [47](#))
- Changing a page mode (☞ [48](#))

## Zooming in (☞ [49](#))

## Adjusting Content View (☞ [52](#))

## Searching

- Finding notes within a book (☞ [44](#)), among books (☞ [46](#))
- Searching keywords (☞ [55](#))
- Searching a book (☞ [34](#))

## **Jumping to a page (☞ [57](#))**

### **Dictionary**

- When reading a book (☞ [60](#))
- As an application (☞ [82](#))
- List of previously looked up words (☞ [63](#))

## **Reading Periodicals (☞ [65](#))**

### **Collection Management**

- Creating (☞ [68](#))
- Adding contents (☞ [70](#))
- Deleting (☞ [72](#))

### **Other Applications**

- Handwriting (☞ [77](#))
- Text Memo (☞ [80](#))
- Picture Viewer (☞ [83](#))
- Audio Player (☞ [85](#))

## **Supported File Formats (☞ [121](#))**

## **Specifications (☞ [19](#))**

## Mobile network and Wi-Fi

- Connecting mobile network (▶ xx)
- Connecting Wi-Fi (▶ xx)
- Reader Store (▶ xx)

## Browsing Internet Content (▶ xx)

# Table of Contents

<b>About the User Guide</b> .....	<b>4</b>
<b>Useful Features</b> .....	<b>5</b>

## Chapter 1

### Overview

Parts and Controls .....	15
Specifications .....	20

## Chapter 2

### Getting Started

Charging the Reader .....	23
Power Saving Tips .....	25

### Basic Operation

Touch Screen .....	28
On-screen keyboard .....	31
Home Menu .....	33



# Getting Content

- Accessing the Reader Store Wirelessly .....36
- Creating Reader Store Account.....39
- Making Purchases .....40
- Downloading Content.....42
- Accessing the Reader Store with your computer .....45
  - Step 1: Installing Reader Library .....47
  - Step 2: Creating an Account and Purchasing eBooks .....49
  - Step 3: Transferring your eBooks to your Reader..51

*Table of Contents*

*Index*

# Chapter 3

## Reading Content

Reading Books.....	54
OPTIONS Menu .....	56
Annotation.....	60
Bookmarking .....	60
Highlighting word(s).....	61
Handwriting a note .....	62
Adding a note.....	63
Finding a Note .....	65
Searching for notes within a book.....	65
Finding the notes in all contents .....	67
Resizing.....	68
Changing a page mode .....	69
Zooming in .....	70
Adjusting Content View .....	73
Screen Orientation.....	75
Searching .....	76
Jumping to a Page .....	78
Using Embedded Dictionaries.....	81
Listing previously looked up words .....	84

Using Wikipedia .....	85
Reading Periodicals .....	87
Reading from Memory Stick™ or SD Card .....	90

## **Browsing Internet Content**

Browsing Websites (Open Browser).....	92
Browsing Web Site .....	92
Registering sites in bookmark.....	94

## **Collections**

Collections .....	98
Creating .....	98
Adding contents.....	99
Deleting a collection.....	100
Removing contents .....	101
Managing Content.....	102
Deleting Content.....	102
Protecting Content .....	103
Managing periodicals.....	104

# Applications

Applications menu.....	106
Using an embedded dictionary .....	107
Creating drawings.....	108
Creating text memos .....	111
Viewing pictures.....	113
Playing audio files .....	115

# Settings

Changing Settings .....	118
[General Settings].....	120
[Application Preferences] .....	121
[System Management] .....	122
[Initialization] .....	124
[Wireless Controls] .....	125
[Wi-Fi Network Settings].....	126

# Troubleshooting

Troubleshooting .....	135
Symptoms.....	136

# Appendix

- Precautions ..... 145
- Copyright Notice ..... 155
  - GNU GENERAL PUBLIC LICENSE..... 157
- Supported File Formats..... 158
- System Requirements..... 160
  
- Index ..... 162

*Table of Contents*

*Index*

# Chapter 1

<b>Overview .....</b>	<b>X - XX</b>
Parts and Controls.....	7
Specifications .....	22

# Parts and Controls

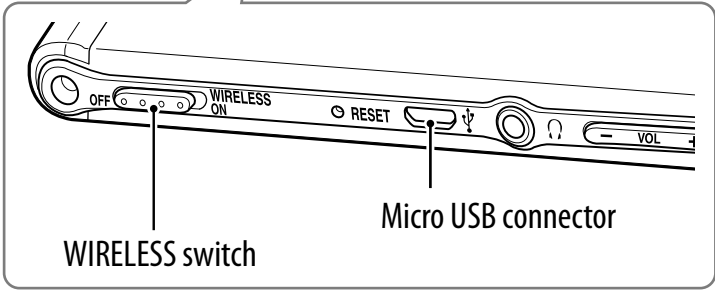
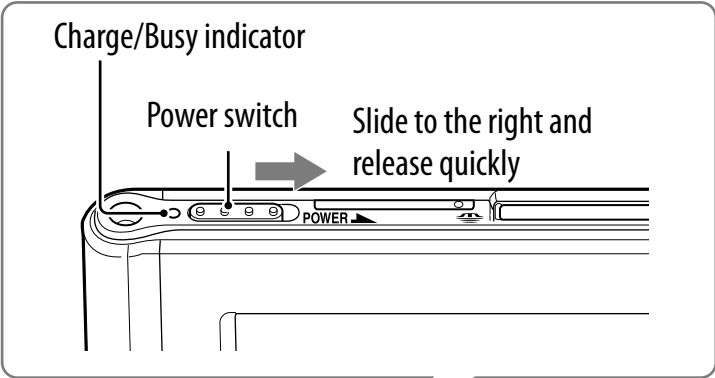

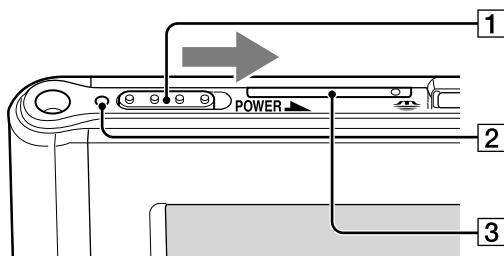

## 1 Power Switch

To	Action
Power on or wake up from sleep mode <sup>1</sup>	Slide to the right and release quickly.
Enter sleep mode	Slide and release quickly. The standby screen <sup>2</sup> appears.
Power off completely	When not in sleep mode slide and hold for more than 3 seconds. Follow the instructions on the screen.

<sup>1</sup> Battery consumption is minimized in sleep mode.

<sup>2</sup> For details about [Standby Screen], see  [94](#).

## 2 Charge/Busy indicator

Red: Charging in progress

Orange: When booting/shutting down/internal memory access

Off: Off/Sleep mode/Reader in operation

## 3 SIM Card Slot

A SIM card is installed to provide wireless communication. Please do not remove it.



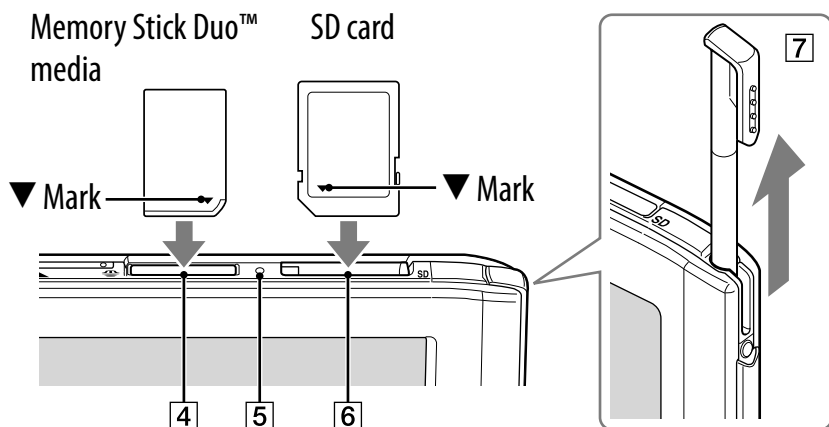

**4 Memory Stick PRO Duo™ slot**

**5 Memory card access indicator**

Lights up in orange during memory card access.

**6 SD card slot**

Please see [122](#) regarding memory card usage.

**7 Stylus**

For more precise operations, use the supplied stylus. Insert fully into the holder when not in use.

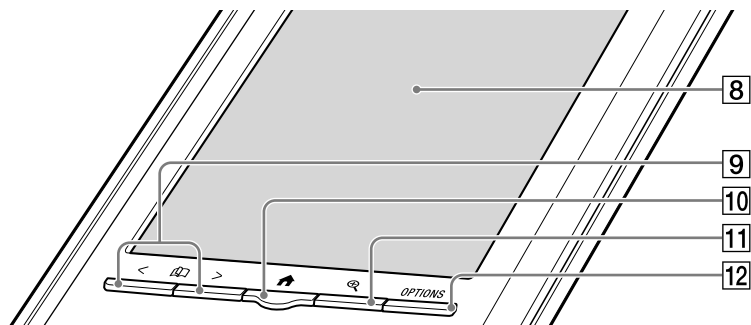

## 8 Touch screen (➤ 23)

Lightly tap the screen either with a finger, or the supplied stylus to navigate.

## 9 Page Turn buttons

Press < (previous) or > (next) to turn the page.  
Press and hold < or > to turn pages continuously.

## 10 Home button (➤ 29)

Shows the [Home] menu.

## 11 Size button (➤ 47)

Shows a utility to change text size, zoom a page and select a page mode.

## 12 OPTIONS button (➤ 31)

Shows the menu for relevant optional functions.

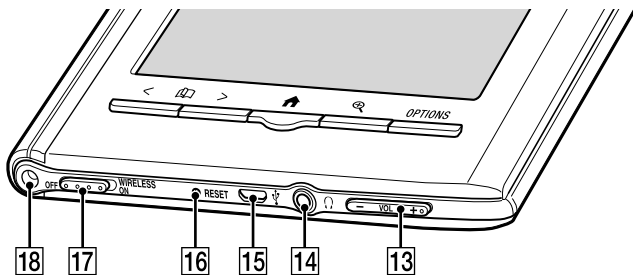

**13 Volume button\* (▶ 87)**

Adjusts the volume when playing an audio file.

\* A tactile dot on the + button helps with ease of operation.

**14 Headphones jack**

**15 Micro USB connector (▶ 12)**

Used for transferring data and charging the Reader.

**16 RESET hole (▶ 96)**

**17 WIRELESS Switch**

Sets to ON when using mobile network or Wi-Fi network.

**18 Holes for optional cover attachment**

With the same hole in the left top corner of the Reader, an optional accessory cover can be attached.

# Specifications

## **Model name**

PRS-950

## **Power source**

Built-in rechargeable battery: 3.7 V DC

AC adapter: 5.0 V DC, 1,500 mA

USB communication: Hi-Speed USB (USB 2.0 compliant)

## **Battery life (continuous playback)**

Maximum Battery: Approx. 12,000 continuous page turns when reading only \*

\* Measured using a fully charged battery and counting consecutive ePub format page-turns at approx 1 page per sec. Actual battery life may vary based on usage patterns and specific device.

## **User available capacity**

Approx. 1.6 GB after initial setting

Depending on size of pre-loaded excerpts, available memory capacity may vary.

## **Operating/charging temperature**

41°F to 95°F (5°C to 35°C)

## **Dimensions (w/h/d)**

Approx. 200 × 128 × 9.6 mm (7 7/8 × 5 1/8 × 13/32 inches)

## **Mass**

Approx. 275 g (9 7/10 oz.)

## **Display:**

7.1" (180.98 mm) diagonal electrophoretic display  
600 × 1,024 pixel, 0.151 × 0.153 pixel/mm

16-level gray scale

**Wireless WAN (3G):**

HSPA/WCDMA 800/850/900/1900/2100 MHz

GPRS/EDGE 850/900/1800/1900 MHz

**Wireless LAN:**

802.11b / g compliant

**Expansion slots**

Memory Stick PRO Duo™ slot, SD card slot

Please see [▶ 122](#) regarding memory card usage.

Design and specifications are subject to change without notice.

# Chapter 2

<b>Getting Started .....</b>	<b>X - XX</b>
Charging the Reader .....	XX
Power Saving Tips .....	XX
<b>Basic Operation .....</b>	<b>X - XX</b>
Touch Screen .....	XX
Home Menu .....	XX
<b>Getting Content .....</b>	<b>XX</b>
Accessing the Reader Store wirelessly .....	XX
Connection Options.....	XX
Reader Store Registration .....	XX
Making Purchases .....	XX
Accessing the Reader Store from your computer .....	XX

# Charging the Reader

Charge your Reader by connecting to an AC outlet using the supplied AC adapter (PRSA-AC1).

The time to completely charge a depleted battery is about 3 hours.

**1 Connect one end of the USB cable to the micro USB connector of the Reader, and the other end to the AC adapter.**

**2 Connect to an AC outlet.**

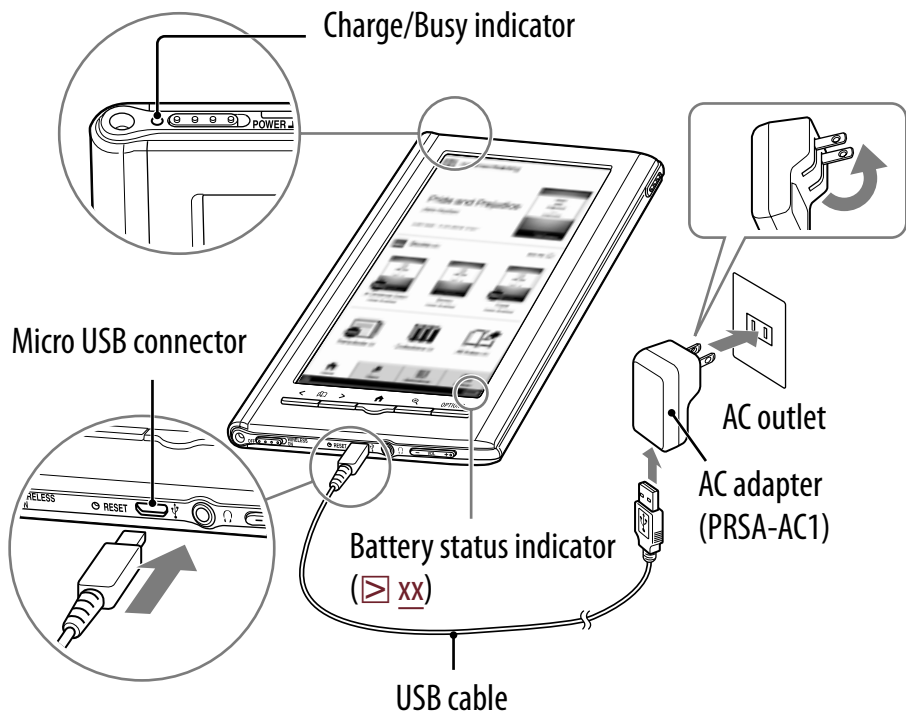

The indicator on the Reader lights up in red while charging, and goes off when charging is completed.



**Notes**

- Do not use an AC adapter other than this one with the Reader.
- Connect the AC adapter to an easily accessible AC outlet. Should you notice an abnormality in the AC adapter, disconnect it from the AC outlet.

**Tips**

- While charging with the optional AC adapter,  appears in the status bar (▶ xx).  appears when fully charged.
- The Reader can also be charged by connecting it to your computer with the USB cable (supplied) (▶ xx). The time to completely charge a depleted battery is about 5.5 hours.



**To check battery status in the status bar (▶ xx) during use**

Charging battery recommended



# Power Saving Tips

## Charging Battery









-  To fully charge your Reader, continue charging until indicator shows completion of charge ([☞ 12](#)).
-  Charging a completely depleted battery will take 3.75 hours when connected to the supplied AC adapter (PRSA-AC1).

## Recommended Temperature





Please use your Reader within the recommended operating temperature range ([☞ 19](#)).

## **More power requiring operations**

The following cases may consume more power.

-  Using mobile network or Wi-Fi network
-  Graphics intensive content
-  Playing audio files
-  Photo slideshow with a short duration
-  Using external memory cards
-  Frequent insertion and ejection of memory cards
-  An excessive number of contents in a memory card
-  ePub and PDF files partially conforming to document standard
-  Annotation, keyword search and dictionary search functions

## Tips to save power

-  If you do not use the Reader for more than one day, power off the Reader completely (▶ [8, 89](#)).
-  Do not leave the Reader uncharged for a prolonged period of time. This may reduce the charging capability.
-  We recommend the supplied AC adapter (PRSA-AC1). The performance of any third party charger is not guaranteed.
-  Please keep the Reader at normal temperature operation (▶ [19](#)).
-  If you do not use mobile network or Wi-Fi, set the WIRELESS switch to OFF (▶ [xx](#)).

# Touch Screen

You can perform various touch operations with a finger or the supplied stylus. (☞ [9](#))

**Single-tapping:** for selecting an item

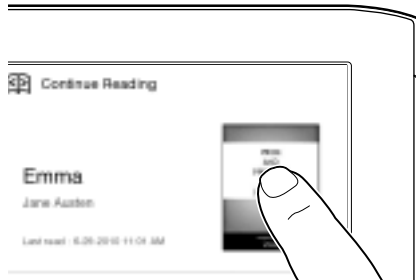

**Double-tapping:** for bookmarks (☞ [39](#)), instant dictionary search (☞ [60](#)), word search (☞ [55](#)), highlighting (☞ [40](#)), etc.

**Example: creating a bookmark (☞ [39](#))**

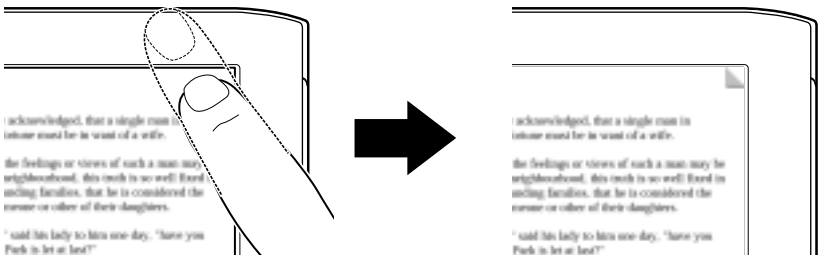

## Tip

To delete a bookmark, double-tap it.

## Swiping

In the page view, swiping the screen turns a page. To change page turn preference, see [☒ 90](#).

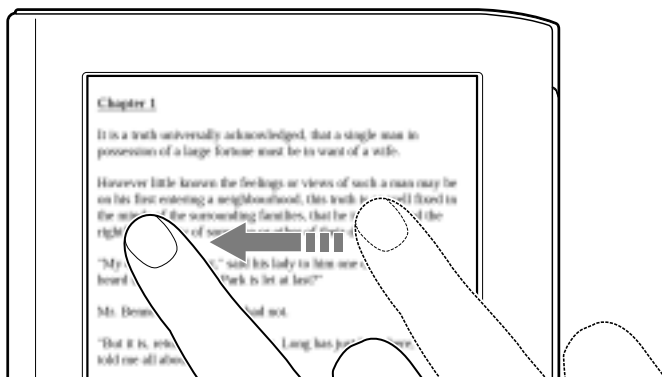

## Swiping and holding

Swipe and hold the page to turn pages repeatedly.

## Dragging

In zoom-in mode (☒ [49](#)), tap and drag to reposition the displayed page. In the [Handwriting] (☒ [77](#)) application or [Create/Edit] function (☒ [41](#)), handwriting on the screen can be performed with the supplied stylus (☒ [9](#)) or a finger.

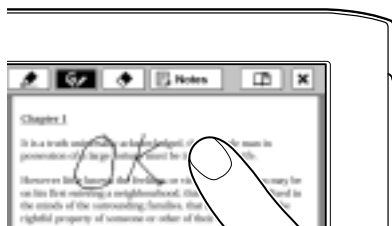

## Double-tapping and dragging

Double-tap the first word, drag to the last word slowly and release to select consecutive words (☒ [40](#)).

# On-screen keyboard



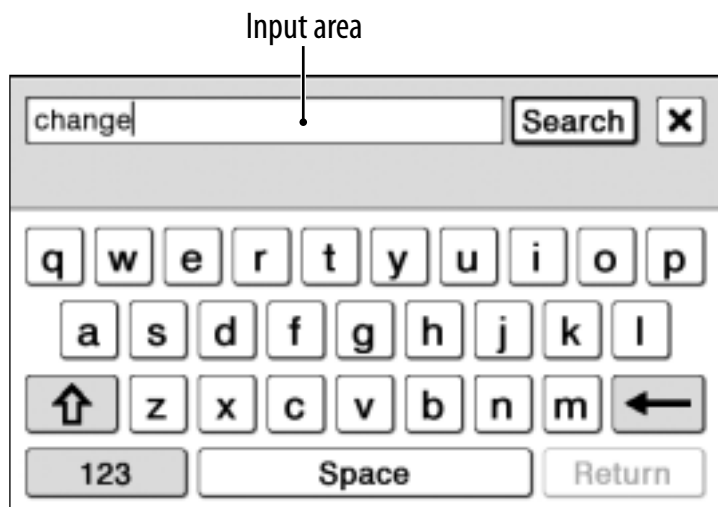

The on-screen keyboard is used for many functions.

## Tip

The key array of the keyboard varies depending on the category of the input text (URL, telephone number, numerical value, etc.).



To	Perform at input area
Edit	Tap to place the cursor.
Delete a character	Tap to place the cursor and tap  to delete a character before the cursor.
Finish inputting	Tap [OK], [Search] or [Done].
Insert line feed	Tap [Return].
	<b>Note</b> [Return] is invalid with [Search].
Switch the keyboard type	Tap [123] to switch to the symbol keyboard. To return, tap [Abc].

To	Perform at input area
Switch the character type	Tap  to switch to the upper-case keyboard. Tap  to switch to additional characters.
Input previously entered words	Tap one of previously entered words shown below the input area. <div data-bbox="388 388 472 433" data-label="Section-Header"><b>Note</b></div> Keyboard history only records (hyphenated) words of 4 to 15 letters. Numbers or other symbols are excluded.
Move the cursor	Tap  /  to move the cursor in input area.

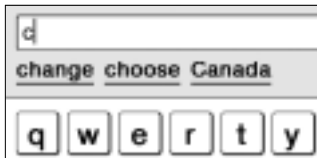

## To input optional characters

Tap and hold an applicable character key will pop up optional characters.





# Home Menu

Press the  (Home) button to display the [Home] menu.

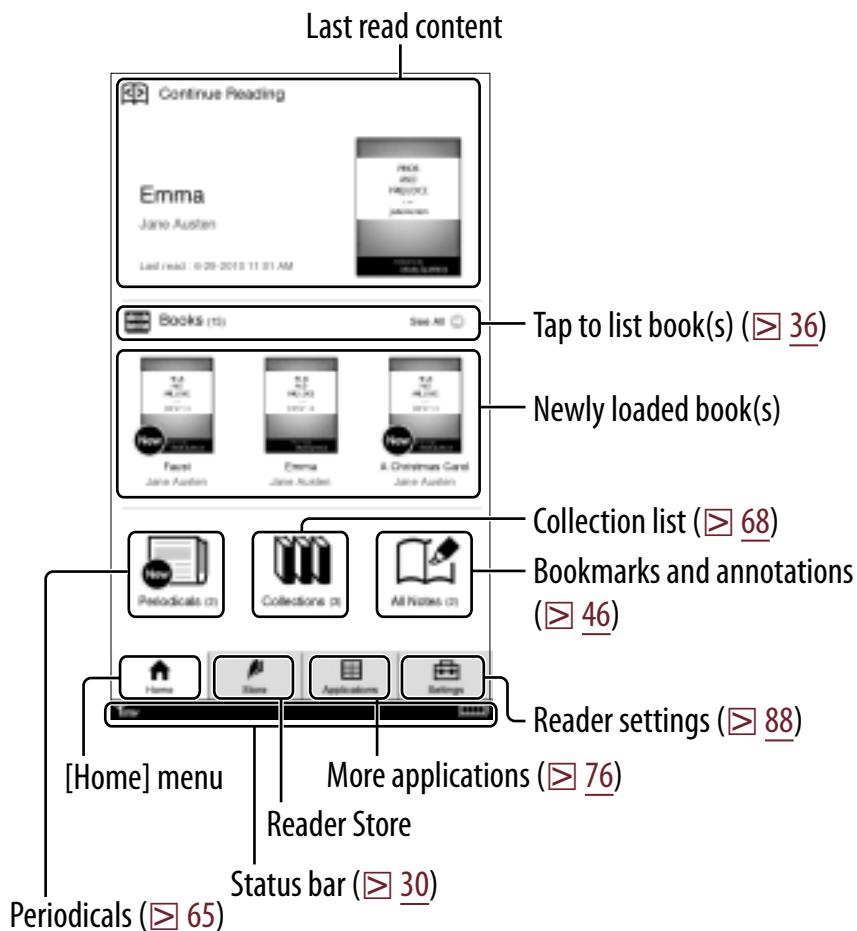





## Tip

[New Delivery] appears when a periodical is transferred.

## About the status bar (☞ 30)



Icon	Description
	Current status indicator of mobile network and Wi-Fi network (☞ <a href="#">xx</a> )
	Mobile network (3G) indicator. This appears when connected to a 3G network, which is faster than a 2G network. The Reader is automatically connected to a 3G network when available.
/	appears when downloading content. appears when connecting and downloading a page in the Reader Store.
	SSL compatible site. The current displayed site is encrypted using SSL.
	Current text Size (☞ <a href="#">47</a> ).
	Current page position in landscape mode (☞ <a href="#">54</a> ).
	Current page position indicator when in either 2 or 3 column split mode (☞ <a href="#">48</a> ).
<b>1 of 234</b>	Page Indicator. Tap this to jump to another page (☞ <a href="#">57</a> ).
<b>17:06</b>	Current time indicator. Reader shows current time in the middle of the status bar for 5 seconds after the OPTIONS button is pressed and returns to the previous display (either blank or page indicator).
	Volume level indicator. This only appears when the volume button is pressed (☞ <a href="#">11</a> , <a href="#">87</a> ).
	An invalid operation.

Icon	Description
	Audio playback in background.
	Battery status indicator ( <a href="#">▶ 13</a> ).
	While charging with the supplied AC adapter (PRSA-AC1),  appears when fully charged.

# Accessing the Reader Store Wirelessly

With mobile network or Wi-Fi connection, you can purchase and download eBooks and periodicals directly from the Reader Store.

Tap  [Store] at [Home] menu. [Wi-Fi Set-up] screen appears.

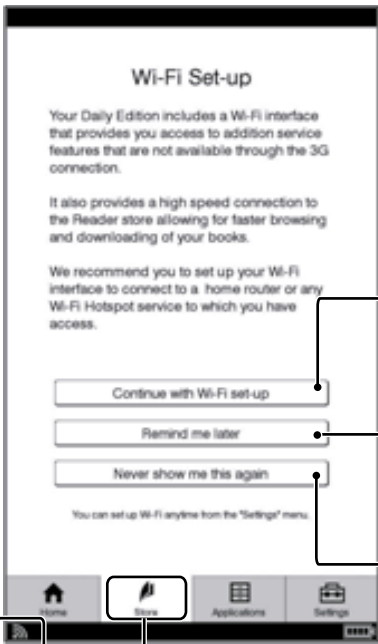

Connect to a Wi-Fi as preference network. Follow the on-screen instruction to set the Wi-Fi network. For details about the Wi-Fi settings, see  [xx](#).

Connect to a mobile network, and set the Wi-Fi network later

Connect to a mobile network without connecting to Wi-Fi\*

Check the network status ( [xx](#))

\* To switch the connection between mobile network and Wi-Fi, see [Wireless Controls] ( [xx](#)).





## To check the network status

You can verify the wireless status by the wireless status icon that is displayed in the bottom left of the screen.

### Mobile network status



For information on the network coverage area, please visit:



<http://www.sony.com/readersupport>

Icon	Status
	The Reader is connected to the mobile network. The more bars, the stronger the signal.
	The mobile network feature of the Reader is in standby mode (☰ <u>xx</u> ).
	The Reader cannot receive a mobile network signal. In this state, you cannot access the Reader Store. When [Mobile Network] is set to [Off] in the [Wireless Controls] setting (☰ <u>xx</u> ), this icon is also displayed
	The WIRELESS switch is set to OFF (☰ <u>XX</u> ).

### Wi-Fi status (after setting Wi-Fi connection)

For details about the Wi-Fi settings, see ☰ xx.

Icon	Status
	The Reader is connected to Wi-Fi. The more bars, the stronger the signal.
	The Wi-Fi network feature of the Reader is in standby mode (☰ <u>xx</u> ).

Icon	Status
	The Reader cannot receive a mobile network signal. In this state, you cannot access the Reader Store. When [Wi-Fi] is set to [Off] in the [Wireless Controls] setting (☑ <u>xx</u> ), this icon is also displayed
	The WIRELESS switch is set to OFF (☑ <u>XX</u> ).

# Creating Reader Store Account

In order to purchase and download eBooks or periodicals, you need to register an account at the Reader Store, or if you already have a Reader Store account or Sony Style account, sign in via your e-mail address and password.



Tap [Create Account]

Enter your e-mail address using the on-screen keyboard (☞ xx). The Reader will be associated with your account in the Reader Store.

# Making Purchases

Browse the Reader Store to find your desired books and purchase them by following the store instructions.

Return to the top page of the Reader Store.



Display the information of the buying history and the credit card.

## OPTIONS menu of the Reader Store

Pressing the OPTIONS button (☰ xx) will display the menu for related supplementary functions.

Item	Description/Reference page
[Store Home]	Displays the top page or the Reader Store.
[My Account]	Displays the [My Account] page.
[Help and Support]	Displays the Reader Store Help page.
[Refresh Page]	Shows the last read page of the content.



<b>Item</b>	<b>Description/Reference page</b>
[Legal Information]	Displays the Reader Store Legal information page.
[Continue Reading]	Shows the last read page of the content.
[Now Playing]	Shows audio player (☞ <a href="#">xx</a> ).
[Resume Playing]	Resumes audio playback (☞ <a href="#">xx</a> ).



# Downloading Content

Select the eBooks that you wish to purchase, and tap [Buy Now]. Follow the on-screen instructions to proceed to the purchasing process.



Tap [Buy Now]

At the end of the eBook purchasing process, [Download completed] is displayed in the status bar and the purchased eBook can be read from the [Home] menu.

Press the  (Home) button  tap the thumbnail of the purchased book.

 is attached to the newly purchased book.

For details about reading books, see ( [xx](#)).

## **Subscribing to newspapers/magazines**

You can subscribe to newspapers/magazines in the Reader Store.

Go to the periodical menu and follow the store instructions.

### **About auto delivery**

Once you have subscribed to newspapers/magazines in the Reader Store, newly published issues will be delivered to the Reader automatically. To ensure this process, confirm:

- The WIRELESS switch is set to ON (☑ xx).
- Check that the [Mobile Network] or [Wi-Fi] is set to [On] in the [Wireless Controls] setting (☑ xx)
- The wireless network is available (☑ xx).

When a new issue is delivered to the Reader, it will be displayed in the [Home] menu. You can also find the issue from the [Periodicals] list and [Collections] list.



[New Delivery]:  
Most recent delivered issues

Purchased book

[Collections]:  
Opens the [Collections] list (☰ xx)

[Periodicals]:  
Opens the [Periodicals] list (☰ xx)

## Notes

- If you miss any new issues while the wireless feature is off, download them from the [My Account] page in the Reader Store, where previous issues are available.
- While the Reader is connected to your computer via USB, the wireless network feature (including the auto delivery feature) is unavailable.

# Accessing the Reader Store with your computer

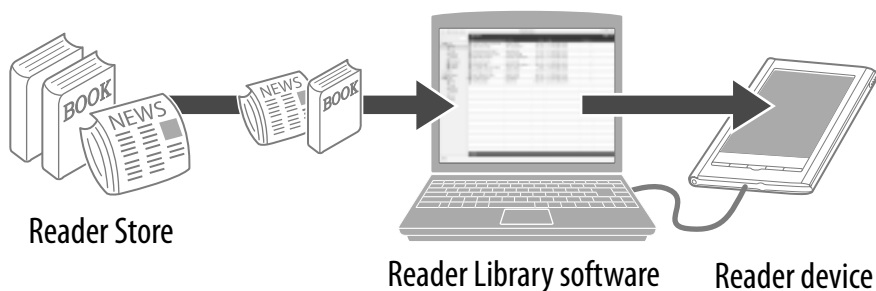

Sony Reader Library software (Reader Library) will allow you to shop and manage eBooks and other content purchased from the Sony Reader Store (Reader Store).

Reader Library can also be used to manage eBooks from other sources such as your local public library or Google Books. For more details, check the Reader™ Store home page.

To help manage your eBooks, you may need to create an account. You'll be asked to do this during the installation process.

Installing Reader Library on to your PC or Mac is easy. There are 3 simple steps to follow.

**Step 1: Installing Reader Library (☞ xx)**

**Step 2: Creating an account and purchasing eBooks (☞ xx)**

**Step 3: Transferring your eBooks to your Reader™ (☞ xx)**

Each of these steps is described in more detail in the next section.

Reader Library has many helpful features. For more information, refer to the Reader Library [Help] menu.

## Step 1: Installing Reader Library

### 1 Connect your Reader to your computer using the supplied USB cable.

Ensure that your Reader is turned on and your computer is switched on, connected to the Internet, and you have Administrator access.

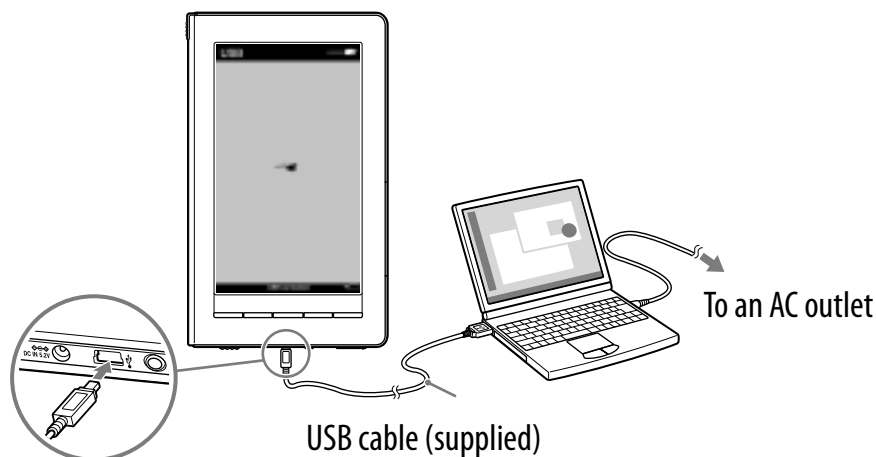

#### Note

- The Reader only charges when the connected computer is powered on.
- The wireless feature is unavailable while the Reader is connected via USB.
- The Reader cannot be operated when connected to a computer via USB.

- 2 For Windows users, go to the “Start” menu and click “My Computer” (or “Computer” for Windows Vista and Windows 7 users). Then double-click the “SETTING” drive and then double-click “Setup Reader Library for Windows”.**

### **To install on Macintosh computers:**

When your Reader is connected to your Mac, “SETTING” and “READER” will appear on the desktop. Double-click the “SETTING” drive and then double-click “Setup Reader Library for Mac”.

- 3 Follow the on-screen instructions to complete the installation of Reader Library.**

A shortcut to Reader Library will be added to your computer desktop (Windows only). Reader Library may start automatically depending on which option you choose just before finishing the installation. If Reader Library does not start automatically, double-click the shortcut to start Reader Library.

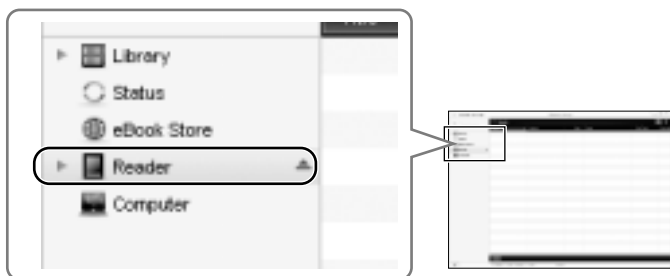



You can navigate around the different sections of Reader Library using the navigation menu on the left-hand side. When your Reader is connected to your computer, you will see [Reader] appear in the list.

To learn how to create an account and purchase eBooks, please read the following section.

## Step 2: Creating an Account and Purchasing eBooks

### 1 Visit Reader Store and create an account.

- 1 Click [eBook Store] in the left-hand menu within Reader Library.

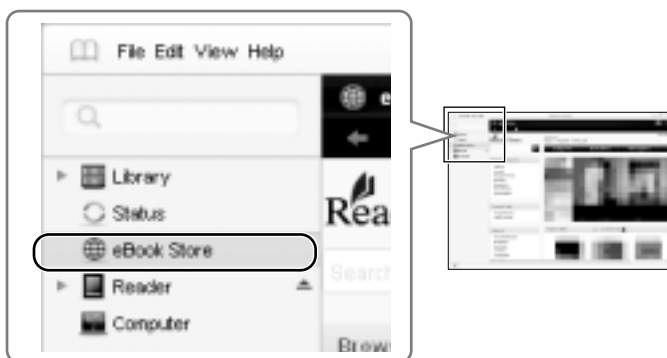

## ② Create an account on the Reader Store.

### **Note**

If you have already created an Adobe Account, use your Adobe ID (this is usually your email address) and password when creating your Reader Store account.

Click the [Register] link. Follow the on-screen instructions to create your Reader Store account (note that the same account details will also be automatically used to create an Adobe Account, which you will need to access eBooks with DRM).

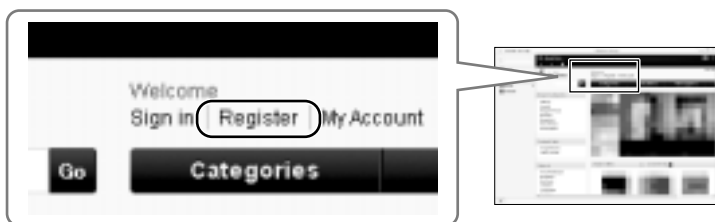

## **2 Purchase and download eBooks.**

Once you set up your account, you can purchase eBooks, subscribe to periodicals and search over 1 million titles from Google Books.

You can also borrow eBooks from your local public libraries. For details, refer to the home page of Reader Store.

All purchased eBooks, subscribed periodicals and free downloads can be found in the [Library] section in the left-hand menu within Reader Library.

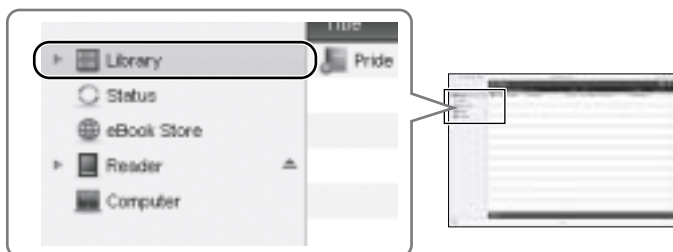

## **Step 3: Transferring your eBooks to your Reader**

- 1 Click [Library] in the left-hand menu within Reader Library.**

- 2 Click on the eBook that you wish to transfer and drag-and-drop it to [Reader] in the left-hand menu.**

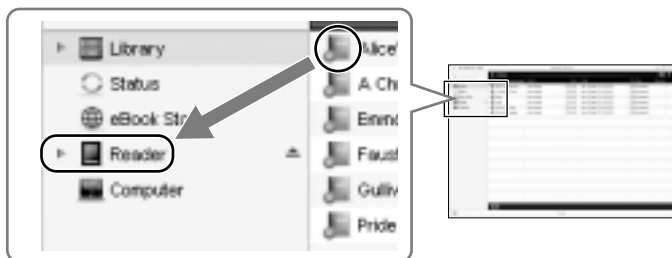

- 3 After a few moments, your eBook will be transferred.**

If the Reader Library does not function as expected, refer to “Troubleshooting” in the Reader Library [Help] menu.

- 4 Close Reader Library and disconnect your Reader from the computer.**

Once Reader Library has closed, the on-screen message on your Reader device will change from [Do not disconnect] to [USB connected].

Once you see [USB connected], it is safe to disconnect your Reader from your computer.

For more details about your Reader, refer to the User Guide found on your Reader.

# Chapter 3

<b>Reading Content</b> .....	<b>42</b>
<b>Browsing Internet Content</b> .....	<b>72</b>
<b>Collections</b> .....	<b>76</b>
<b>Managing Content</b> .....	<b>XX</b>
<b>Applications</b> .....	<b>82</b>
<b>Settings</b> .....	<b>98</b>
<b>Troubleshooting</b> .....	<b>105</b>
<b>Appendix</b> .....	<b>113</b>

# Reading Books



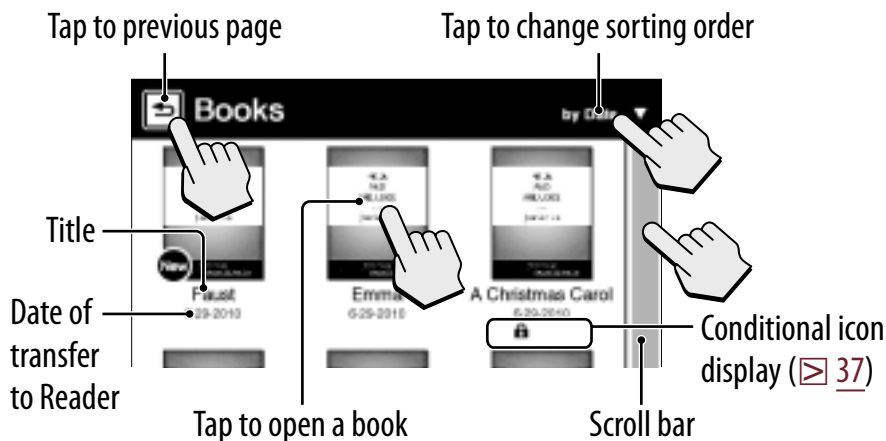

Tap  [Books] at [Home] menu to view a book list. Tap a desired book to open.



## Tips

- Please see ☒ [xx](#) regarding OPTIONS menu.
- To transfer eBooks to the Reader, please see ☒ [xx](#).

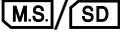
## Conditional icon

Icon	Condition
	Newly transferred or unread content.
	Protected content (☒ <a href="#">75</a> ).
	Content on a memory card.
	Days to the expiration date. [Expired] is displayed when a book has expired.

## Operation at page view

Swipe the screen to turn page

Double-tap to bookmark

: Handwritten memo. Tap to show its thumbnail. Tap the thumbnail to display in full size.

: An added note. Tap to view the added note.

Double-tap to open dictionary/search/add highlight

Tap to jump to another page

The diagram illustrates a page view interface with several interactive elements. At the top left, a handwritten memo icon is shown with a callout explaining its function. A vertical line indicates that swiping the screen turns pages. At the top right, a hand icon double-taps a small bookmark icon. In the center, a hand icon swipes the page. At the bottom left, a hand icon double-taps a menu icon. At the bottom right, a hand icon taps a page number '5 of 36'. The page content is a snippet of text from 'Pride and Prejudice'.

# OPTIONS Menu

Pressing the OPTIONS button (☒ 10) will display the menu for related supplementary functions.

## Items in the OPTIONS menu

The following items are listed in alphabetical order. When displaying the OPTIONS menu, not all items listed below will be shown in any given circumstance.

Item	Description/Reference page
[Add Content], [Add to Collection]	Adds content to a collection (☒ 70).
[Add Bookmark]	Creates a bookmark on the page (☒ 39).
[Adjust View]	Adjusts how content is displayed (☒ 52).
[Change Dictionary]	Shows a list of dictionaries to select.
[Continue Reading]	Shows the last read page of the content.
[Delete Book], [Delete Drawing], [Delete Issue], [Delete Memo]	Deletes the currently-viewed book, drawing, issue or text memo from the Reader.
[Delete Audio], [Delete Books], [Delete Collections], [Delete Drawings], [Delete Issues], [Delete Memos], [Delete Notes], [Delete Pictures]	Selects and deletes audio, books, collections, drawings, issues, text memos, notes or pictures from the Reader (☒ 74).



<b>Item</b>	<b>Description/Reference page</b>
[Delete Word Logs]	Selects and deletes previous dictionary word searches (☒ <a href="#">64</a> ).
[Go to]	<b>[Previous View]:</b> Jumps to the previously viewed page (☒ <a href="#">59</a> ). <b>[History]:</b> Navigates previously-viewed pages. (☒ <a href="#">59</a> ) <b>[Select Page]:</b> Jumps to another page (☒ <a href="#">58</a> ). <b>[Table of Contents]:</b> Displays the table of contents.
[Info]	Displays the content information.
[Manage Subscription]	Sets to delete issues automatically (☒ <a href="#">xx</a> ).
[New Collection], [New Drawing], [New Memo]	Creates a new collection (☒ <a href="#">68</a> ), a drawing (☒ <a href="#">77</a> ) or a text memo (☒ <a href="#">80</a> ).
[Notes]	<b>[List]:</b> Displays the [Notes] list in the content (☒ <a href="#">44</a> ). <b>[Create/Edit ]:</b> Shows tools to bookmark, highlight, handwrite and remove annotations (☒ <a href="#">41</a> ). <b>[Hide]/[Show]:</b> Toggle displaying annotations (☒ <a href="#">59</a> ).
[Now Playing]	Shows audio player (☒ <a href="#">86</a> ).
[Orientation]	Toggles the screen orientation either in portrait or landscape mode (☒ <a href="#">54</a> ).
[Previous View]	Returns to the previously viewed page.

<b>Item</b>	<b>Description/Reference page</b>
[Protect Audio], [Protect Books], [Protect Drawings], [Protect Issues], [Protect Memos], [Protect Pictures]	Protects audio, books, drawings, issues, text memos or pictures from accidental deletion (☒ <a href="#">75</a> ).
[Remove Bookmark]	Deletes the bookmark on the page (☒ <a href="#">39</a> ).
[Remove Content]	Removes content from a collection (☒ <a href="#">73</a> ).
[Rename Collection]	Changes the collection name (☒ <a href="#">69</a> ).
[Repeat]	Sets repeat play of audio files (☒ <a href="#">87</a> ).
[Resume Playing]	Resumes audio playback (☒ <a href="#">87</a> ).
[Return to List]	Shows content list.
[Search]	Searches for either content title or words in the contents with the keyword inputted by on-screen keyboard (☒ <a href="#">56</a> ).
[Select Standby Screen]	Selects pictures for the standby screen (☒ <a href="#">84</a> ).
[Shuffle On]/ [Shuffle Off]	Plays all audio files in a random order (☒ <a href="#">87</a> ).
[Slideshow On]/ [Slideshow Off]	Starts/Stops a slideshow of pictures (☒ <a href="#">83</a> ).
[Sort:]	Changes sort order of the list (☒ <a href="#">36</a> ).
[View]	Changes the appearance of the list.

<b>Item</b>	<b>Description/Reference page</b>
[Word Logs: Book] [Word Logs: Periodical]	Within either a book or a periodical, shows a list of the last 100 words previously searched in the dictionary (▶ <a href="#">63</a> ).
[Word Logs: Dictionary]	Within a dictionary, shows a list of the last 100 words previously searched (▶ <a href="#">61</a> ).
▲/▼	Displays the previous/next OPTIONS menu.

**Tip**

Pressing and holding the OPTIONS button for 2 seconds is the same as tapping  or pressing OPTIONS ➔ tapping [Return to List].

# Annotation

## Bookmarking

Creating:

- Double-tap the upper right corner of page. When the pages are displayed in [Two Page View] mode, the bookmark can be created by double-tapping the left corner of the left page. (☒ [xx](#)).
- From the OPTIONS menu: [Add Bookmark] (☒ [31](#))
- From the OPTIONS menu: [Notes] ➔ [Create/Edit] (☒ [41](#))

Deleting: Double-tap a bookmark.

Adding a note in a bookmark: See ☒ [42](#).

## Highlighting word(s)

Highlighting at page view:

- A word: Double-tap a word.
- Consecutive words: Double-tap and drag (☞ 25).
- At pop-up tool window, tap  marker to highlight.

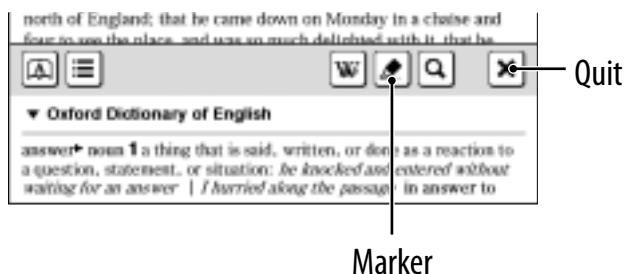

- Highlighting can be done in the OPTIONS menu: [Notes] ➔ [Create/Edit] (☞ 41).

Deleting:

- From the OPTIONS menu: [Notes] ➔ [Create/Edit] (☞ 41).

Adding a note in a highlight: See ☞ 42.

## Handwriting a note

Press **OPTIONS** → tap [Notes] → [Create/Edit] →  → use a stylus or finger to draw a line.

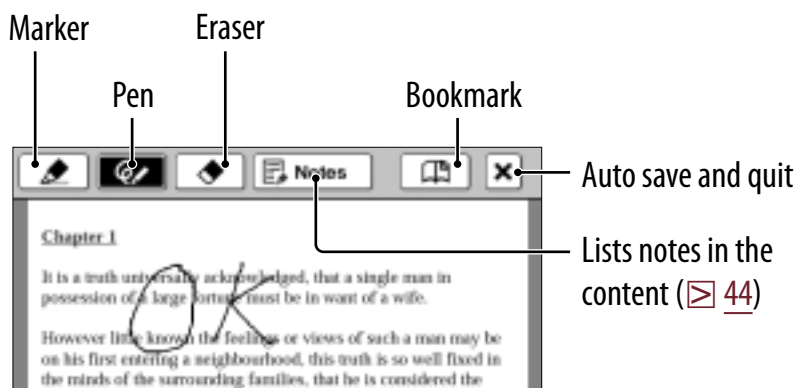

Deleting a drawn line/highlight: Tap  and stroke across the drawn line or highlight.

### Notes

- While writing, make sure that you are not touching another area on the screen – this could affect the notes that you write with the stylus or your finger.
- To ensure your notes are correctly saved, do not handwrite notes too close to the edge of the screen.
- If you experience difficulties when handwriting or drawing on your Reader:
  - avoid applying excessive pressure to the screen.
  - try not to handwrite or draw too quickly.
  - the notes functionality is not designed for very detailed drawings or for writing small characters.

# Adding a note

## 1 Tap a bookmark or highlighted word → [by Drawing] or [by Keyboard].

To enter a handwritten note, tap [by Drawing].

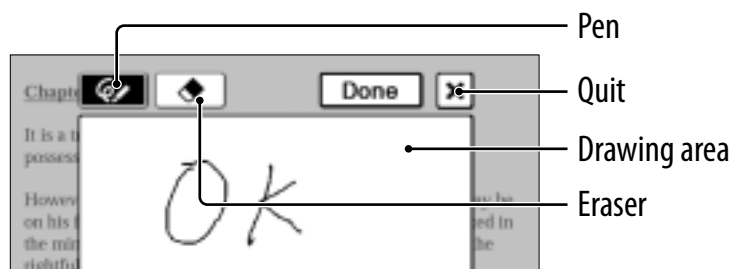

To enter a memo with typed in text (☑ [26](#)), tap [by Keyboard].

### Note

When adding a note to the highlighted text in [Create/Edit], unselect any annotation tool icon and then tap the highlight.

## 2 Enter a note → tap [Done].

☰ will be attached to the bookmark or highlight. To view the added note, tap a bookmark or highlight with ☰.

## Notes

- While writing, make sure that you are not touching another area on the screen – this could affect the notes that you write with the stylus or your finger.
- To ensure your notes are correctly saved, do not handwrite notes too close to the edge of the screen.
- If you experience difficulties when handwriting or drawing on your Reader:
  - avoid applying excessive pressure to the screen.
  - try not to handwrite or draw too quickly.
  - the notes functionality is not designed for very detailed drawings or for writing small characters.

### To edit a note

Tap a bookmark or highlight with  → [Edit] → edit a note → tap [Done].

### To delete a note

Tap a bookmark or highlight with  → [Delete] → [Yes].



# Finding a Note

## Searching for notes within a book

### 1 Press **OPTIONS** → tap **[Notes]** → **[List]**.

A list of all the bookmarks, highlights, and handwritten memos in the current book appears.

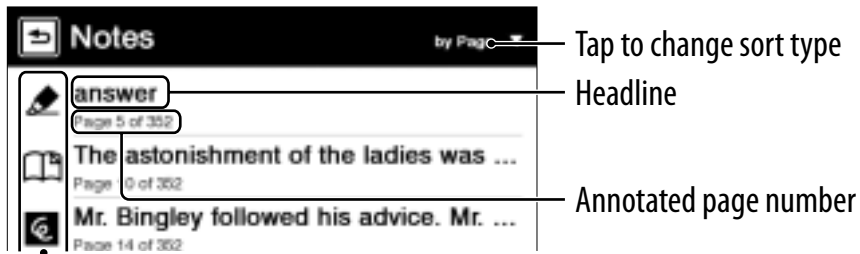

Types of note (☒ 45)







### Tip

Please see ☒ xx regarding OPTIONS menu.

### 2 Tap a note.

The page containing the selected note is displayed.

## Icons and types of note in the [Notes] list

Icon	Types of note
	Bookmark
	Bookmark with a handwritten note
	Bookmark with a text note
	Highlight
	Highlight with a handwritten note
	Highlight with a text note
	Handwritten memo

### Tip

You can set to merge the notes of the Reader and Reader Library when synchronizing. For further instructions, refer to Reader Library Help.

# Finding the notes in all contents

## 1 Tap [All Notes] at [Home] menu.

A list of all the bookmarks, highlights, and handwritten memos in all contents appears.

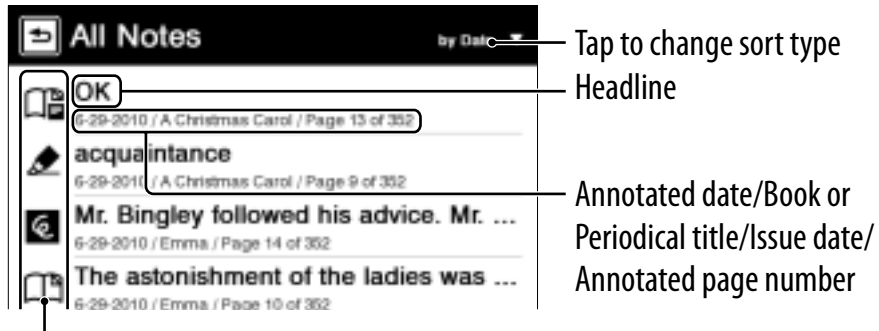

Types of note ( 45)

### Tip

Please see  xx regarding OPTIONS menu.

## 2 Tap a note on the list.

The page containing the selected note is displayed.

# Resizing

Press  $\oplus$  ( $\boxtimes$  10) for re-sizing.

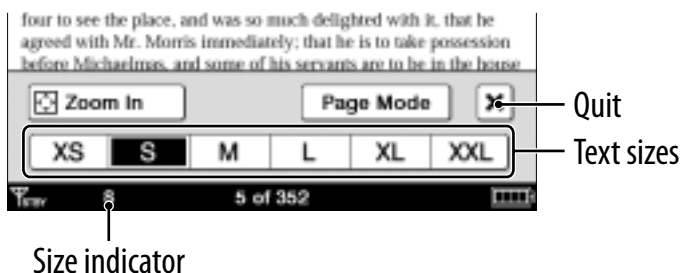

Adjusting the text size: Select one of text size icons and close.

## Notes

When you view PDF files in a size other than [S], the following may occur.

- [S] size is the default font size. If another size is selected, text size may not change correctly.
- Functions such as highlighting, searching, or temporary word selection may not work correctly.
- The table and graphics may not be correctly displayed.
- A page containing only images cannot be resized.

## Changing a page mode

A page can be magnified by selecting the page mode.

- 1 Press **⊕** → tap **[Page Mode]**.
- 2 Tap a desired item from the following.

### [Page Mode] menu

[Page Mode] item	Description
[Original]	Displays the original page layout.
[Margin Cut] <sup>1</sup>	Removes the margins.
[2-Column Split]	Displays the page in numerical order by dividing the page into four.
[3-Column Split]	Displays the page in numerical order by dividing the page into six.
[Full Page] <sup>2</sup>	Expands the page to a full page.
[Two Page View] <sup>3</sup>	The pages are displayed horizontally, side by side.

<sup>1</sup> Depending on the content, you may not be able to enlarge a page.

<sup>2</sup> [Full page] mode is only effective when the screen is in landscape display (☒ 54).

<sup>3</sup> [Two Page View] is available only in the landscape (horizontal) mode. When selecting [Two Page View] in the portrait (vertical) mode, the screen orientation is switched to the landscape (horizontal) mode automatically.

#### Note

In order to attach a handwritten memo, the page mode needs to be restored to [Original].

# Zooming in

The current page in view can be magnified. Also, the magnification can be locked so that the desired setting can be maintained. This feature is useful when reading a book containing scanned images.

## 1 Press $\oplus$ $\rightarrow$ tap $\left[ \begin{array}{c} \oplus \\ \ominus \end{array} \right]$ Zoom In].

### Tip

Pressing  $\oplus$  and  $>$  simultaneously at the page view screen instantly magnifies the page by 10%.

## 2 Drag the zoom slider, or tap + or – of the zoom bar repeatedly until the page is zoomed to the desired scale.

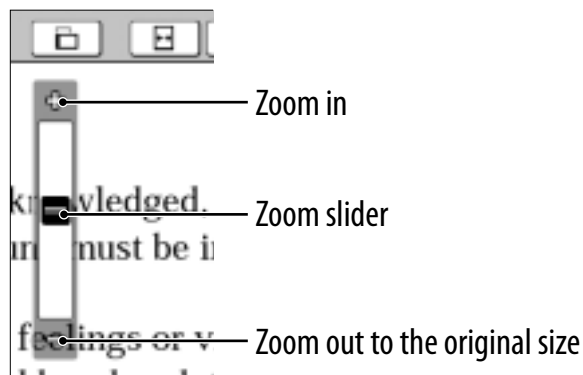

## Zooming a specified image or column to the screen size

While in zoom-in mode, double-tap an image or column which you wish to magnify.







The image or column size is magnified automatically to fit the screen size, and the magnification is locked.



### Tip

When in zoom-in mode, you may move to the next/previous page at zoom lock ([⊕ Lock]) mode.

## Using the zoom-in mode

Tap	To
	Switch the screen orientation.
	Fit the page width to the screen width.
	Fit the page height to the screen height.
[⊕ Lock]	Lock the zoom ratio and the magnified area. The book can be read as it is.
[⊕ Unlock]	Return to the zoom-in mode. To keep the zoom locked screen, press  to quit. When opening the book next time the zoom locked screen will be restored.
 *	Scroll the page. You can also scroll the page by dragging or tap on a page where you want to zoom in.
	Check which part on the page is displayed.
	Return to original view.

\* Displays when in zoom-in mode.

### Note

- In zoom-in mode, page links are not available.



# Adjusting Content View

A page that is hard to read, such as a scanned or color converted document, can be made more readable by adjusting the brightness and contrast.

**1 Press **OPTIONS** → tap **[Adjust View]**.**

**2 Tap the desired item from the following.**

Item	Description
[Original]	Displays the page in the original quality.
[Saturated]	Improves readability by emphasizing contrast.
[Details]	Backlight compensation; brings up details in a dark area.
[Brighter]	Increases the brightness.
[Darker]	Decreases the brightness.
[Custom]	Custom setting mode (☒ <a href="#">53</a> ).



**3 Tap **[X]** to apply the setting and exit.**

The change will only be stored in the content being adjusted. Select [Original] when it is necessary to restore the default setting.

## Custom setting mode

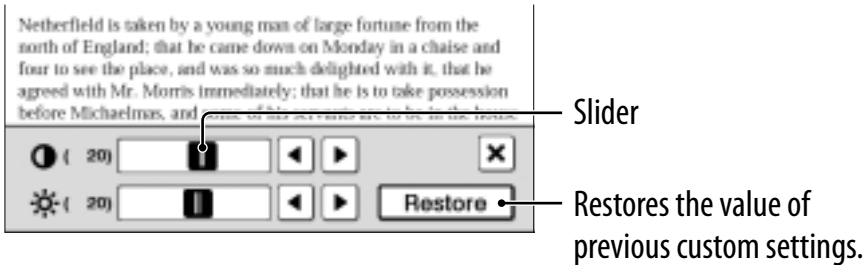
- 1 Tap  → drag the slider, or tap  or  repeatedly until the page is adjusted to the desired brightness and contrast.



- 2 Tap  to apply the setting and exit. The change will only be stored in the content being adjusted. Select [Original] ( 52) when it is necessary to restore the default setting.

# Screen Orientation

The screen orientation can be switched to either portrait (vertical) or landscape (horizontal) mode by selecting [Orientation] in any OPTIONS menu.

To change the direction of screen rotation, see [Screen Orientation] (☞ [88](#)).

## Portrait



## Landscape

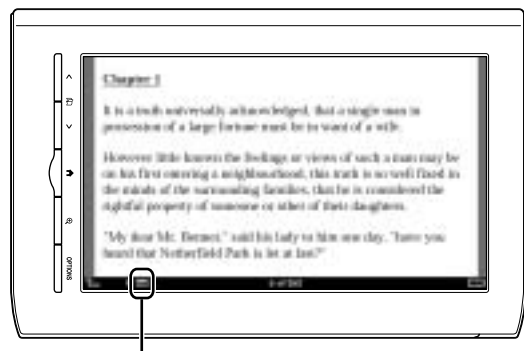

Position indicator

# Searching

## By selecting a word(s)

- To select a word, double-tap a desired word at page view.
- To select consecutive words, see “Double-tapping and dragging” (☞ 25).

The following screen will appear.

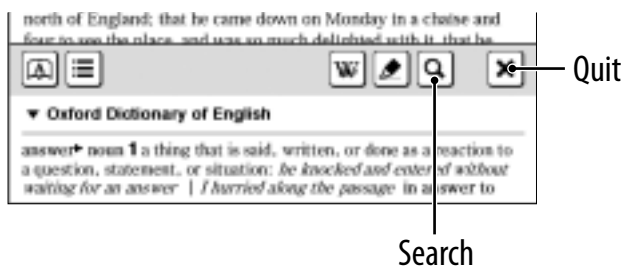

- To cancel, tap **X** and tap anywhere on the page view.
- To search the selected word(s), tap **Q**.

The search result screen will appear. The results are highlighted on the page.

- To cancel, tap **X** and quit.
- To navigate, tap **Q←** or **→Q** to move to the previous/next result.

## From the on-screen keyboard

- 1 Press OPTIONS → tap [Search] → input a word using the on-screen keyboard (☒ 26) → tap [Search].**

The search result screen will appear. The results are highlighted on the page.

- 2 Tap  or  to move to the previous/next result.**

To cancel, tap  and quit.

### Tip

Before searching, a selected word can be modified. Double-tap a word → press OPTIONS → tap [Search] → modify the word in the input area of the on-screen keyboard → tap [Search].

# Jumping to a Page

## By using the slider

Tap the page number shown in the status bar → drag the slider, or tap a point on the page jump bar.

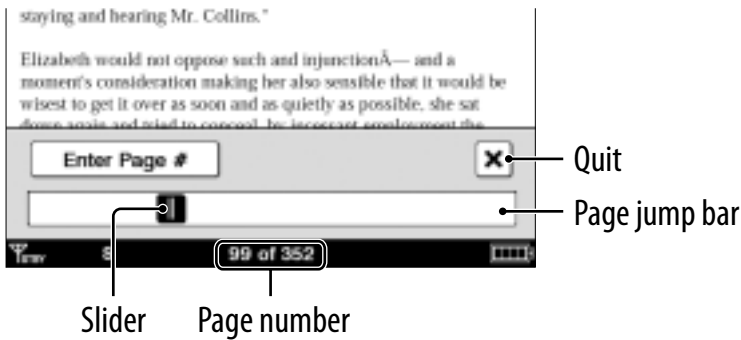

## Tip

Jumping to a page can be done from the OPTIONS menu. Press OPTIONS → tap [Go to] → [Select Page].

## By page number

Tap the page number shown in the status bar ➔ [Enter Page #] ➔ tap the number keys to input a page number ➔ [Go]. You will jump to the specified page.

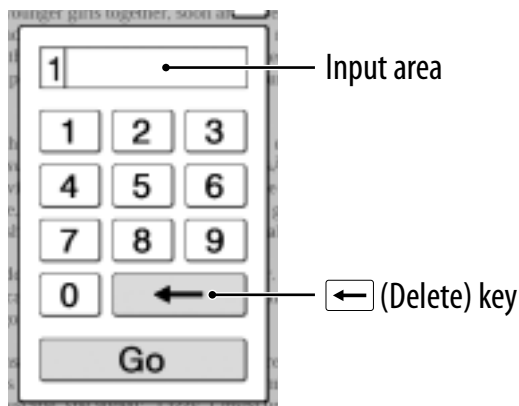

If the input page number exceeds the number of pages in the book, the Reader will show the last page. If 0 is input, the first page will be displayed.

## **By tapping a link**

The link appears highlighted on the screen. Tap the link to jump to the linked page.



### **Note**

If a hyperlink is covered with highlighting, press **OPTIONS** → tap [Notes] → [Hide] to hide highlighting.

## **Returning to the previously displayed page**

Press **OPTIONS** → tap [Go to] → [Previous View].

## **Jump to viewed pages**

Press **OPTIONS** → tap [Go to] → [History] →  (previous view) or  (next view) → .



# Using Embedded Dictionaries

An instant search for a meaning or translation is possible with the embedded dictionaries.

## 1 Double-tap a word.

The headline of the word definition is displayed.

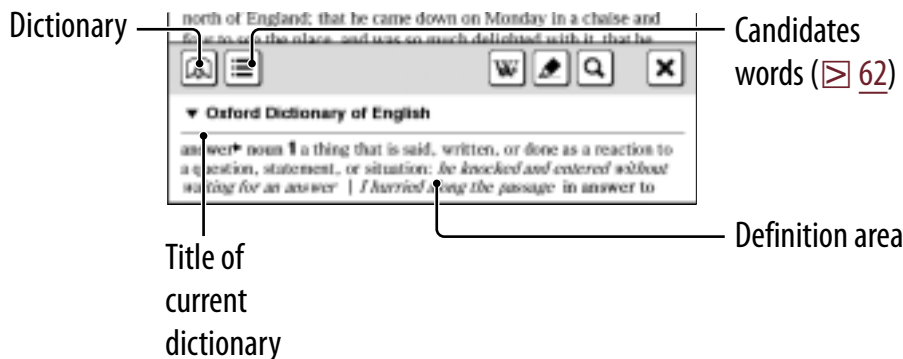



## Tips

- Tap ▼ to switch and search in another dictionary.
- Reader comes with 5 embedded dictionaries.
  - 2 English dictionaries
  - 3 Translation dictionaries

An English word can be translated to French, German, Spanish, Italian or Dutch, or vice versa.

## 2 Tap or the definition area.

The definition is displayed in-full in the dictionary viewer. To go to the next page, either swipe the screen or press <  > (Page Turn) buttons ( [10](#)).

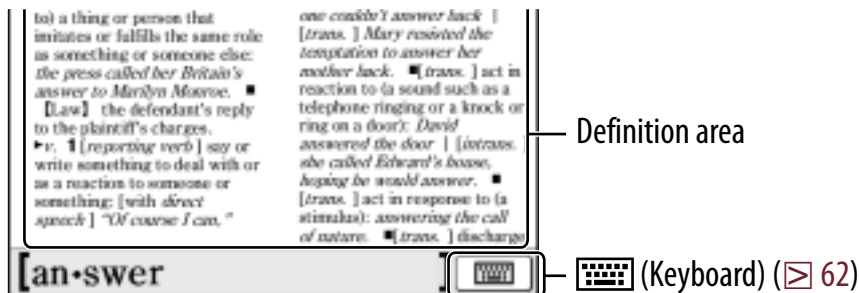

### Tips

- Double-tapping a word in the definition area will look up the selected word in the same dictionary. To return to the previously viewed definition page, press **OPTIONS** ➔ tap [Previous View].
- From the **OPTIONS** menu, following functions can be done.
  - Changing to another dictionary and searching again.
  - Listing previously looked up words in the selected dictionary ( [63](#)).

## To list words with same head letters as previously entered words

Tap  or  (keyboard)  26.

The list of candidate words changes dynamically whenever the word in the input area is modified.

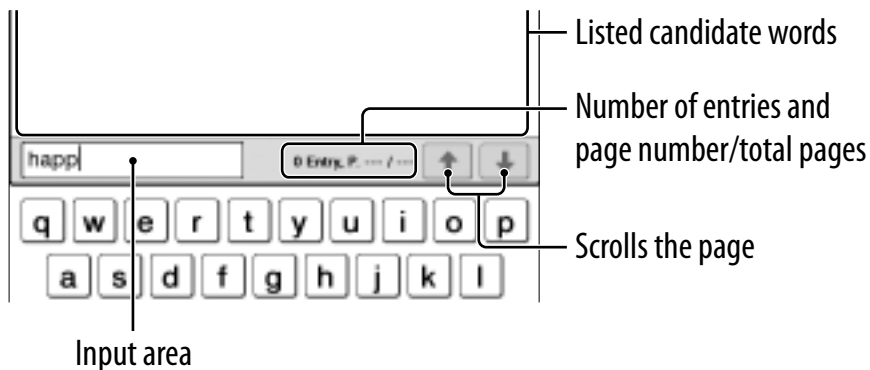

## Listing previously looked up words

- 1 At page view, press **OPTIONS** ➔ tap **[Word Logs: Book]**.

The looked up words are listed in the order of most recently looked up.

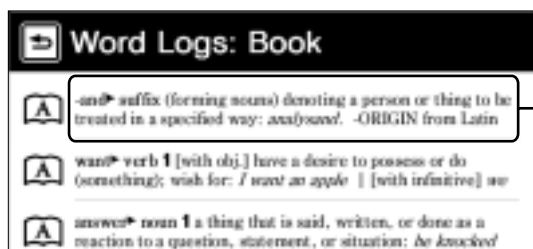

Word and definition

- 2 Tap a desired word.

### To delete word logs

Press **OPTIONS** ➔ tap **[Delete Word Logs]** ➔ tap the check box of each word to be deleted ➔ **[Done]** ➔ **[Yes]**.

#### Tip

A list of looked up words within a dictionary can be also viewed by pressing **OPTIONS** ➔ tap **[Word Logs: Dictionary]** when viewing the definition area (☞ [61](#)) or the candidate word list (☞ [62](#)).

# Using Wikipedia

A word or text can be searched for a information using Wikipedia (only when connected to a Wi-Fi network).

## 1 Double-tap a word.

The headline of the word definition is displayed.

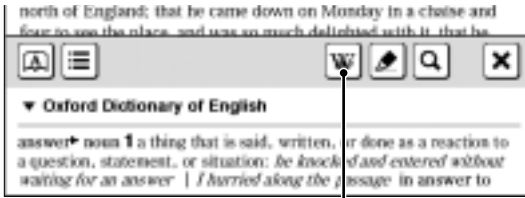

Wikipedia

## 2 Tap W [Wikipedia].

The Wikipedia page appears.



### Tips

- Wikipedia can be used when connecting Wi-Fi network. If [Continue with Wi-Fi set-up] is displayed, tap [Setting] to make the Wi-Fi network settings. (☞ xx).
- Please see ☞ xx regarding OPTIONS menu.

# Reading Periodicals

You can read newspapers/magazines from  [Periodicals] in the [Home] menu.

## 1 Tap [Periodicals] at [Home] menu.

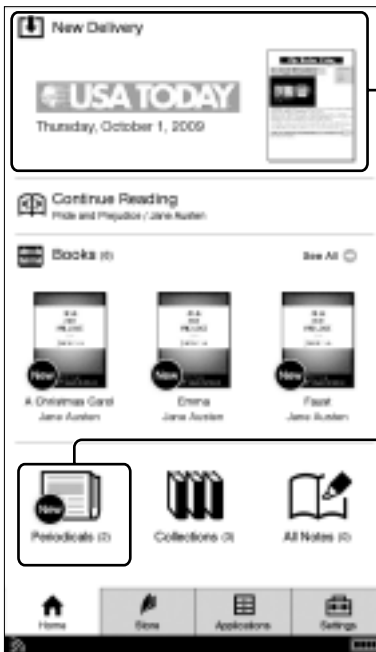

[New Delivery]:  
Most recent delivered issue

[Periodicals]:  
Opens the [Periodicals] list

### Tip

If you want to read most recent delivered issue, tap [New Delivery] at [Home] menu and read the issue ( [70](#)).

## 2 Tap a desired periodical to go to issue list.

### 3 Tap a desired issue in the list.

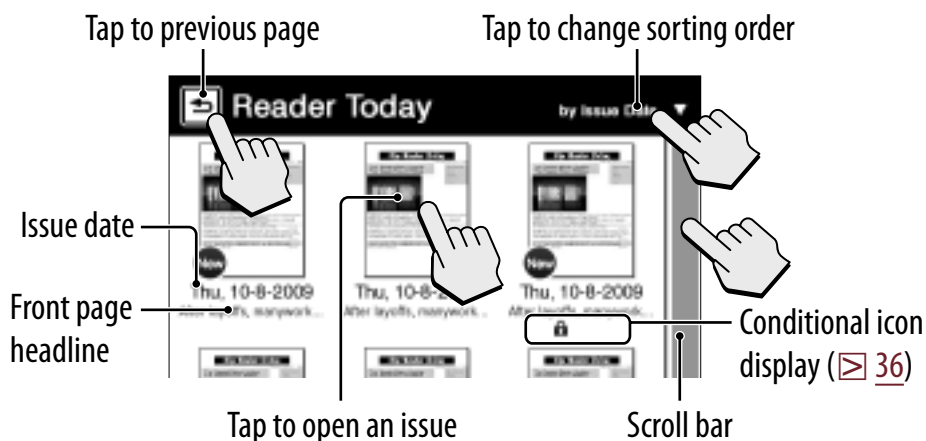

#### Tip

Please see [☒ xx](#) regarding OPTIONS menu.

### 4 Use the navigation bar to read.

#### Operations on a section



#### Operations on an article

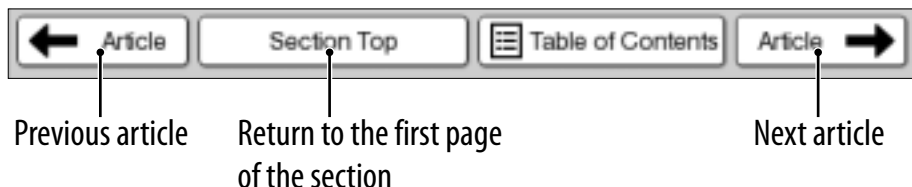



**Tips**

- Annotations can be added (☒ [39](#)).
- Please see ☒ [xx](#) regarding OPTIONS menu.

**To delete a issue(s)**

Tap [Periodicals] at [Home] menu ➔ tap a periodical to go to issue list ➔ press OPTIONS ➔ tap [Delete Issues]. To delete, refer to the example instructions for deleting books in “Deleting Content” (☒ [xx](#)).

To protect, refer to the example instructions for protecting books in “Protecting Content” (☒ [xx](#)).

# Reading from Memory Stick™ or SD Card

You can transfer the purchased content on your computer to a memory card by using Reader Library. The content on a memory card can be read by inserting the memory card with the Reader (☒ [xx](#)). For details transferring content to a memory card, refer to Reader Library Help.



## Tips

- If there is not enough free space on the Reader memory, content on the Reader can be transferred to a memory card by using Reader Library.
- You can group desired content on a memory card as a collection. For details about collections, see ☒ [xx](#) or refer to Reader Library Help.

## Note

The Reader cannot transfer content to memory cards directly. Use Reader Library to transfer content.

## Reading books on a memory card

Tap  [Books] at [Home] menu to view a book list, Tap a book with  /  to open.

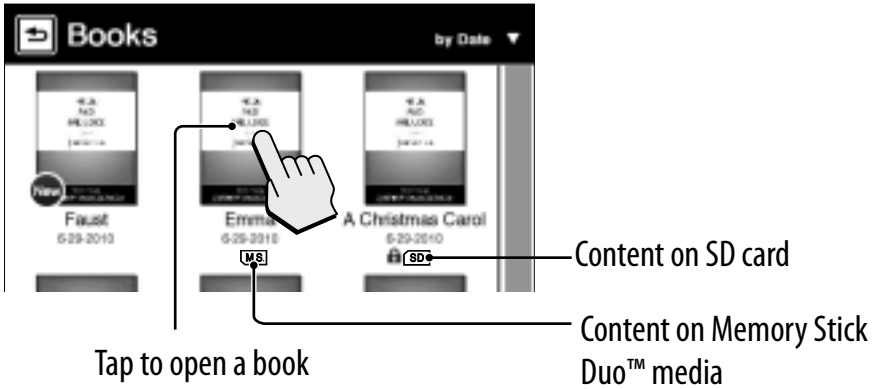

# Browsing Websites (Open Browser)

Web site can be browsed only when connected to a Wi-Fi network.

Before accessing a Web site, confirm:

- The WIRELESS switch is set to ON. (☑ xx).
- Check that the [Mobile Network] or [Wi-Fi] is set to [On] in the [Wireless Controls] setting (☑ xx)
- The wireless network is available.

## Browsing Web Site

- 1 Tap  [Open Browser] under  [Applications] at [Home] menu.**

### Tips

- If [Continue with Wi-Fi set-up] is displayed, tap [Setting] to make the Wi-Fi network settings. (☑ xx).
- About [Applications] menu, see (☑ xx).

- 2 Tap the link of the desired Web site in the Browse Home page.**

## To display Web site by selecting Web Bookmarks

- 1** At the Browse Home page or Web site page view, press **OPTIONS**.
- 2** Tap **[Bookmarks]**.
- 3** Tap the bookmark of the desired Web site.

### Tip

For details on adding Web Bookmarks, see “Registering sites in bookmark” (☒ [xx](#)).

## To display a Web site by inputting its URL directly

- 1** In the Browse Home page or Web site page view, press **OPTIONS**.
- 2** Tap **[Input URL]**.
- 3** Input the URL of the desired Web site → tap **[OK]**.

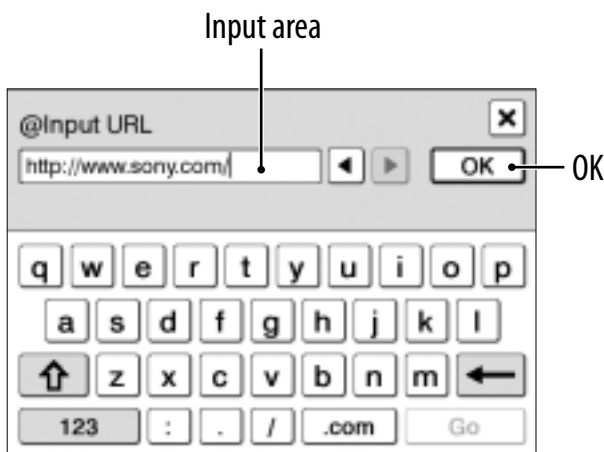

## Registering sites in bookmark

- 1** A Web site page view you want to add to Web Bookmark, press **OPTIONS**.
- 2** Tap [Add to Bookmark].

## To delete a Web Bookmark

- 1** In the Browse Home page or Web site page view, press **OPTIONS** → tap [View Bookmarks].
- 2** Press **OPTIONS**.
- 3** Tap [Delete Bookmarks].
- 4** Tap the check box of each bookmark to be deleted.

### Tips

- To delete all bookmarks, press **OPTIONS** after step 3 above → tap [Select All].
- To undelete all bookmarks, press **OPTIONS** after step 3 above → tap [Unselect All].

- 5** Tap [Done] → [OK].

## **To Edit the content of Web Bookmarks**

- 1 At Web Bookmarks page view, press OPTIONS.**
- 2 Tap [Edit Bookmarks].**
- 3 Tap a desired Bookmark → tap an item to edit.**
- 4 When the edit is completed, tap [OK].**
- 5 Tap [OK].**

## **To delete a Web Bookmark**

- 1 In Web Bookmarks page view, press OPTIONS.**
- 2 Tap [Delete Bookmarks].**
- 3 Tap the check box of each bookmark to be deleted.**

### **Tips**

- To delete all bookmarks, press OPTIONS after step 3 above → tap [Select All].
- To undelete all bookmarks, press OPTIONS after step 3 above → tap [Unselect All].

- 4 Tap [Done] → [OK].**

## OPTIONS menu of Open Browser

Pressing the OPTIONS button (☰ xx) will display the menu for related supplementary functions.

The following items are listed in alphabetical order. When displaying the OPTIONS menu, not all items listed below will be shown in any given circumstance.

Item	Description/Reference page
[Add to bookmark]	Adds currently displayed Web site to the Bookmark (☰ <u>xx</u> ).
[Bookmarks]	Displays the Web Bookmarks (☰ <u>xx</u> ).
[Browse Home]	Returns to the Browse Home page while activating the Open Browser (☰ <u>xx</u> ).
[Continue Reading]	Shows the last read page of the content.
[Delete Bookmarks]	Deletes the Web Bookmark selected (☰ <u>xx</u> ).
[Edit Bookmarks]	Edits the contents of selected Web Bookmarks (☰ <u>xx</u> ).
[Input Address]	Displays the URL input page while activating the Open Browser (☰ <u>xx</u> ).
[Legal Information]	Displays the Legal Information page of currently displayed Web site.
[Now Playing]	Shows audio player (☰ <u>xx</u> ).
[Resume Playing]	Resumes audio playback (☰ <u>xx</u> ).
[Page Info]	Displays the information of currently displayed Web site (☰ <u>xx</u> ).
[Refresh Page]	Refresh the display of currently displayed Web site.



<b>Item</b>	<b>Description/Reference page</b>
[Stop]	XXXXXXXXXX.
[Take Screenshot]	Saves the screenshot of the currently displayed Web site (☒ <u>XX</u> ).

# Collections

## Creating

You can group desired content in Reader as a collection.

- 1 Tap  [Collections] at [Home] menu → [New Collection].**

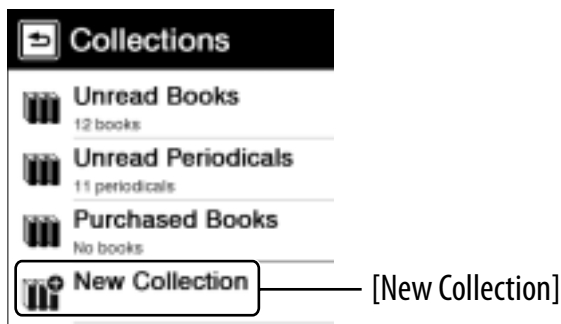

### Tip

Press **OPTIONS** → tap [New Collection] to create a collection.

- 2 Enter the collection name using the on-screen keyboard (  [26](#) ) → tap [OK].**
- 3 Tap [Internal Memory], [Memory Stick™] or [SD Card] to select where you want to create the collection → tap [OK].**

A new collection is created in the [Collections] list.

**Tip**

You can create/sync a collection by Reader Library. For details, refer to the Reader Library Help.

**To change a collection name**

In the [Collections] list, tap the collection → press **OPTIONS** → tap [Rename Collection] → enter a new collection name using the on-screen keyboard → tap [OK].

**Adding contents****From the collections****Note**

Only content in the same physical location as the selected collection can be added.

- 1 Tap  [Collections] at [Home] menu → tap a created collection.**
- 2 Press **OPTIONS** → tap [Add Content] → [Books] or [Periodicals].**  
In the periodical list, select a periodical and then select issues.
- 3 Tap the thumbnail of a desired content → [Done].**

## From either the books or issues list

- 1** In the books or issues list, press **OPTIONS** → tap **[Add to Collection]**.
- 2** In the collection list, tap a collection you want to add the content.
- 3** Tap the thumbnail of the desired content → **[Done]**.

You can check added content in the collection list.

### Tip

To select all books or issues, press **OPTIONS** in the **[Add Books]** or **[Add Issues]** list → tap **[Select All]**.

## Deleting a collection

Even if you delete a collection, all contents in the collection will remain undeleted on the Reader.

- 1** Tap  **[Collections]** at **[Home]** menu.
- 2** Press **OPTIONS** → tap **[Delete Collections]**.
- 3** Tap the check box of each collection to be deleted → **[Done]** → **[Yes]**.

### Tip



Also, you can delete a collection using Reader Library. For details, refer to the Reader Library Help.

## Removing contents

Even if you delete content in a collection, the corresponding content will remain undeleted on the Reader.

- 1 Tap  [Collections] at [Home] menu → tap a collection.**
- 2 Press OPTIONS → tap [Remove Content].**
- 3 Tap the thumbnail of each content to be deleted → [Done] → [Yes].**

### Tips

- To select all contents, press OPTIONS after step 2 above → tap [Select All].
- When you delete contents in  [Books] or  [Periodicals], corresponding contents are also deleted from relevant collections.

# Managing Content

## Deleting Content

Example: [Books] list

### 1 Tap [Books] → press **OPTIONS** → tap [Delete Books].

To delete: tap a book thumbnail with the blank check box.

To delete all: press **OPTIONS** → tap [Select All].

To undelete: tap a book thumbnail with a checked check box.

To unselect all: press **OPTIONS** → tap [Unselect All].

### 2 Tap [Done] → [Yes].

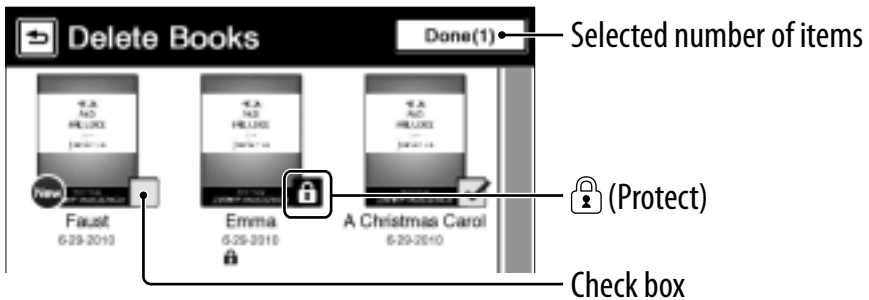

### Tip

You can also delete the currently viewed book. Press **OPTIONS** in the page view → tap [Delete Book] → [Yes].

# Protecting Content

Example: [Books] list

## 1 Tap [Books] ➔ press **OPTIONS** ➔ tap [Protect Books].

To protect: tap a book thumbnail with .

To protect all: press **OPTIONS** ➔ tap [Protect All].

To unprotect: tap a book thumbnail with .

To unprotect all: press **OPTIONS** ➔ tap [Unprotect All].

## 2 Tap [Done].

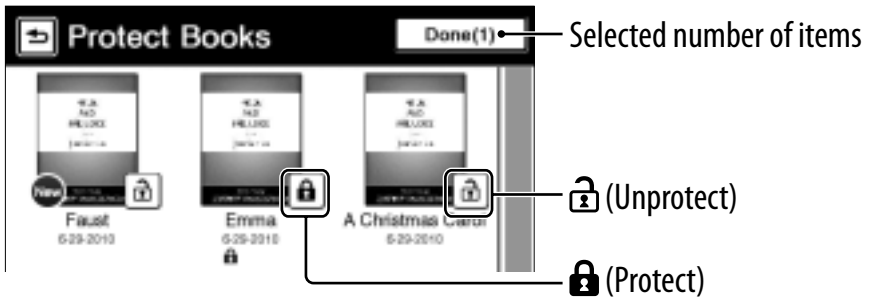

### Note

This protection feature works only on the Reader. Protected content may still be deleted via your computer.

# Managing periodicals

In the issue list, you can keep only recent issues and delete previous issues automatically.

- 1 Tap  [Periodicals] at [Home] menu → tap a periodical.**
- 2 Press OPTIONS → tap [Manage Subscription].**

The management dialog appears.

How many issues do you want to keep from this subscription on your Reader?

Note: Protected issues are not included in this count.

5 issues       90 issues  

---

 10 issues       All issues  



---

 30 issues

Delete extra issue(s) now.

- 3 Tap the desired setting → [Save]**

## Tips

- If you want to delete extra issues immediately, tap [Delete extra issues now.] → [Save]. In the confirmation dialog, tap [Yes].
- If you have issues that you do not want to delete, protect them using [Protect Issues] in the OPTIONS menu ( xx).



## **Notes**

- You cannot manage periodicals on memory cards via the Reader.
- If the number of issues in the list is less than your selected number, [Delete extra issues] will not delete any issues.

# Applications menu

The [Applications] menu provides useful functions, such as listening to music while reading a book, creating a text or a handwritten memo, and more.

Tap  [Applications] at [Home] menu.

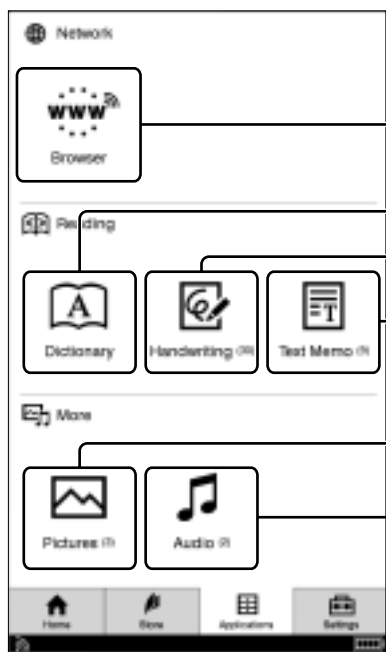

Open Browser ([☞ xx](#))

To use the currently selected dictionary ([☞ 82](#))

To list/create handwritten note(s) ([☞ 77](#))

To create/edit/view text memo(s) ([☞ 80](#))

To list all pictures ([☞ 83](#))

Audio player ([☞ 85](#))

# Using an embedded dictionary

- 1 Tap  [Dictionary] under  [Applications] at [Home] menu.**

The name of the currently selected dictionary is shown at the top of the screen. To switch to another dictionary, press **OPTIONS** → tap [Change Dictionary].

- 2 Input a word using the on-screen keyboard ( [26](#)) → tap a candidate word.**

The definition is displayed in-full in the dictionary viewer ( [61](#)).



## To list words with same head letters as the inputted word

Tap  (keyboard).

## To list previously looked up words

Press **OPTIONS** → tap [Word Logs: Dictionary]. To delete word logs, see ( [63](#)).

# Creating drawings

- 1 Tap  [Handwriting] under  [Applications] at [Home] menu.
- 2 Tap [New Drawing].

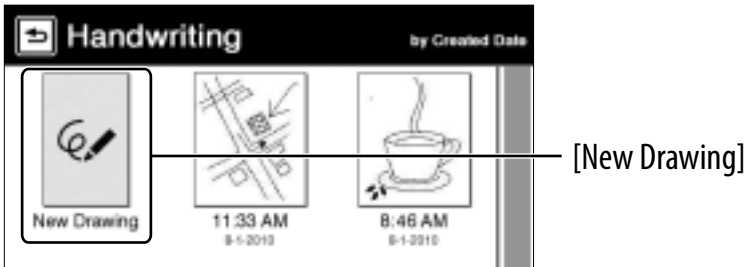

## Tip

Press OPTIONS → tap [New Drawing] to create a drawing.

- 3 Draw in the drawing area with the supplied stylus or your finger → tap [Done].

To erase a line, tap  → tap or stroke a part of the line.

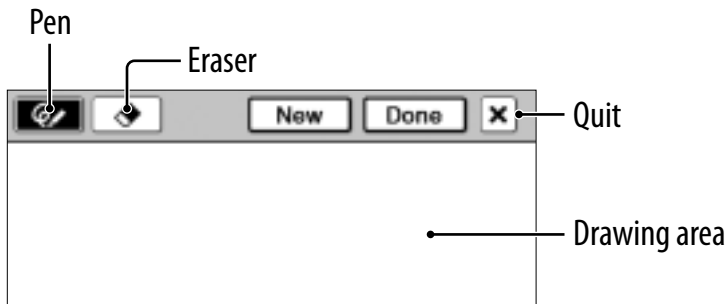

## **Tips**

- If you tap [New], the current drawing is saved, and a new drawing editor opens.
- Newly created drawings will be saved only in the internal memory.



## **Notes**

- While writing, make sure that you are not touching another area on the screen – this could affect the notes that you write with the stylus or your finger.
- To ensure your notes are correctly saved, do not handwrite notes too close to the edge of the screen.
- If you experience difficulties when handwriting or drawing on your Reader:
  - avoid applying excessive pressure to the screen.
  - try not to handwrite or draw too quickly.
  - the notes functionality is not designed for very detailed drawings or for writing small characters.

## **Viewing/editing created drawings**

After step 1 (☞ [77](#)), tap a drawing thumbnail to view. Tap [Edit] and follow step 3 above.

## To delete/protect a drawing(s)

Tap  [Handwriting] under  [Applications] at [Home] menu, press OPTIONS ➔ tap [Delete Drawings] or [Protect Drawings].



To delete, follow the instruction after tapping [Delete Books] in “Deleting Content” ( [74](#)).

To protect, follow the instruction after tapping [Protect Books] in “Protecting Content” ( [75](#)).

### Tip

After step 1 ( [77](#)), tap a drawing thumbnail to view and press OPTIONS ➔ tap [Delete Drawing] to delete the currently viewed drawing.

## Creating text memos

- 1 Tap  [Text Memo] under  [Applications] at [Home] menu.
- 2 Tap [New Memo].



### Tip



Press **OPTIONS** → tap [New Memo] to create a text memo.

- 3 Enter text in the input area using the on-screen keyboard ( [26](#)) → Tap [Done].



### Tips

- If you tap [New], the current text memo is saved, and a new text memo editor opens.
- Newly created text memos will be saved only in the internal memory.

## Viewing/editing text memos

After step 1 ( [80](#)), tap a memo to view. Tap [Edit] and follow the step 3  [xx](#).

## To delete/protect a text memo in the list

Tap  [Text Memo] under  [Applications] at [Home] menu, press OPTIONS ➔ tap [Delete Memos] or [Protect Memos].

To delete, refer to the example instructions for deleting books in “Deleting Content” ( [74](#)).

To protect, refer to the example instructions for protecting books in “Protecting Content” ( [75](#)).

### Tip

After step 1 ( [80](#)), tap a memo to view and press OPTIONS ➔ tap [Delete Memo] to delete the currently viewed memo.





# Viewing pictures

You can view pictures stored in either internal memory or a memory card. Also, you can set your favorite pictures to the standby screen.

**1 Tap  [Pictures] under  [Applications] at [Home] menu.**

**2 Tap a thumbnail of desired picture on the list.**

## Tips

- Please see  [xx](#) regarding OPTIONS menu.
- See “Supported File Format” ( [121](#)).
- To transfer pictures to the Reader using Reader Library, refer to Reader Library Help.

## To set slideshow

Press OPTIONS → tap [Slideshow On].

To set the duration of a slideshow, see [Slideshow] of [Application Preferences] ( [xx](#)).

## To set as a standby screen

In the [Pictures] list, press **OPTIONS** ➔ [Select Standby Screen] ➔ tap the thumbnail of candidate picture ➔ tap [Done].

The [Standby Screen] setting is configured from the [Settings] menu ( [94](#)).

### Tip

When two pictures or more have been selected, the displayed picture is changed every time the Reader enters the sleep mode ( [xx](#)).

## To zoom in a picture



Press  ( [xx](#)) to switch to the zoom-in mode.

### Tip



Double-tap where you wish to zoom in further. The double-tapped area will be shown centered automatically after zooming in.

# Playing audio files

You can enjoy audio files with optional headphones.

- 1 Tap  [Audio] under  [Applications] at [Home] menu.**
- 2 Tap a desired album to go to the audio list.**
- 3 Tap a desired audio file, and play an audio file.**  
The playback screen appears ( [xx](#)).

## Tips

- Please see  [xx](#) regarding OPTIONS menu.
- See “Supported File Formats” ( [121](#)).
- To transfer audio files to the Reader using Reader Library, refer to Reader Library Help.

## Note

- An album or an audio file with cover art information can only display its thumbnail in the album list.

# Playback screen operations

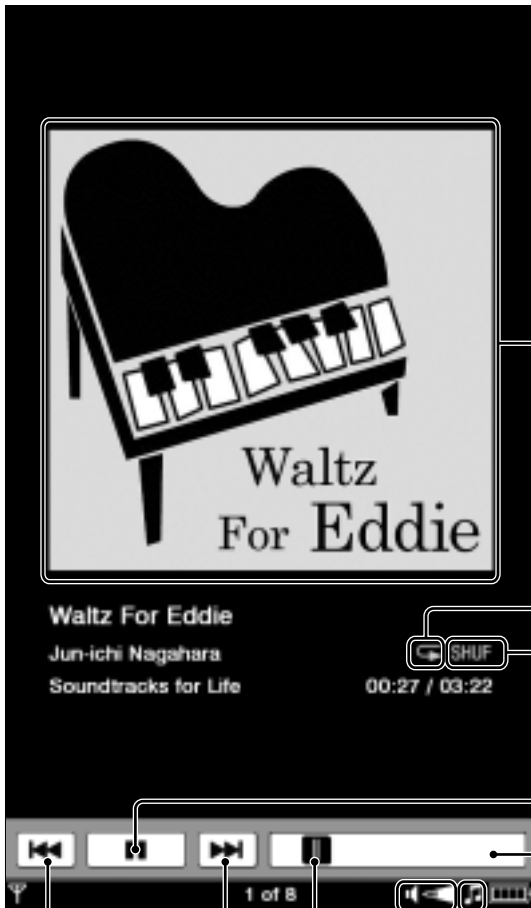

Cover art

Repeat icon

Shuffle icon

Play/pause

Playback progress bar

Playback icon appears during playback

Volume indicator

Skip to the beginning of the previous (or current if played more than 3 seconds from the beginning) audio file

Skip to the beginning of the next audio file

Playback position

To	Do this
Pause a song	Tap <b>  </b> .
Resume playback	Tap <b>▶</b> .
Skip to the previous/ next track	Swipe the playback screen.
Skip to the beginning of the previous (or current) audio file/beginning of the next audio file	Tap <b>⏮</b> / <b>⏭</b> .  <b>Note</b> Skips to the beginning of the current audio file if played more than 3 seconds from the beginning.
Fast-reverse/ fast-forward an audio file	Drag the playback position indicator, or tap on the playback progress bar.
Control the volume	Press the volume button. The volume indicator will appear in the status bar.
Repeat songs	Press <b>OPTIONS</b> ➔ tap [Repeat] ➔ tap [Off], [One Song] or [All Songs]. <b>↺ 1</b> : Repeat one song <b>↺</b> : Repeat all songs in the album
Shuffle songs	Press <b>OPTIONS</b> ➔ tap [Shuffle On] or [Shuffle Off]. <b>SHUF</b> : Shuffle play
Mute playback	Press and hold the volume button. To resume, press the volume button again.

# Changing Settings

Tap  [Settings] at [Home] menu.

## **[General Settings] ( 90 )**

- [Date and Time]
- [Date and Time Format]
- [Page Turn Preference]
- [Menu Language]
- [Keyboard]
- [Screen Orientation]

## **[Application Preferences] ( 91 )**

- [Dictionary]
- [Slideshow]

## **[System Management] ( 92 )**

- [Power Management]
- [Device Lock]
- [Standby Screen]

## **[Initialization] ( 95 )**

- [Restore Defaults]
- [Clear Keyboard History]
- [Format Memory]

**[Wireless Controls]** (☞ xx)

**[Wi-Fi Settings]** (☞ xx)

**[About]**

Displays system and legal information of the Reader.

**[Device Shutdown]**

Shuts down (power off) the Reader completely.

## **[General Settings]**

### **[Date and Time]**

Tap a field to change.

Input a number by tapping the numeric key pad.

Tap [OK] to apply the change.

#### **Tip**

The date and time of your Reader will be automatically synchronized to your computer by the Reader Library after connection.

### **[Date and Time Format]**

Tap [Month-Day-Year] or [Day-Month-Year] to select the date format.

Tap [12 hour] or [24 hour] to select the time format.

Tap [OK] to apply the changes.

### **[Page Turn Preference]**

Sets the swiping direction to turn pages forward.

Swiping to left is default setting.

### **[Menu Language]**

Selects the language of the Reader's menu and messages.

### **[Keyboard]**

Selects a preferred on-screen keyboard.



## **[Screen Orientation]**

Sets the direction to rotate when changing from portrait to landscape mode.

## **[Application Preferences]**

### **[Dictionary]**

Selects a default dictionary to use.

### **[Slideshow]**

Sets the slideshow on/off and its duration up to 60 seconds.

#### **Note**

Slideshow may take a longer time to display depending on the size of picture.

# [System Management]

## [Power Management]

Power management helps avoid unnecessary battery consumption.

Power management operates as follows:

- After 10 minutes of inactivity, the Reader enters the sleep mode automatically and battery consumption is minimized.
- After three\* days of inactivity, the Reader automatically shuts down and stops consuming battery power.

\* If battery power is at a low level, the Reader will shut down within three days of inactivity.

### **Note**

The Reader does not enter the sleep mode after 10 minutes of inactivity even if [Power Management] is set to [On], when:

- connected to a computer using the supplied USB cable
- charging with an AC adapter (PRSA-AC1) (optional)
- playing an audio file or when a slideshow is set

## [Device Lock]

Locks the Reader by setting a pass code.

Tap [On] to set a pass code.

Input a 4-digit number by tapping the numeric key pad.

Tap [OK] to lock the Reader.

To unlock, input the pass code and tap [OK]. Then tap [Off] to unlock the Reader, and tap [OK].

### Notes

- [0000] is the factory setting.
- You are recommended to make a note of your password and keep it in a safe place separate from the Reader.
- If you forget your password, contact your Sony Customer Support (☎ [18](#)); however, note that in unlocking your device, all content on it will be erased.
- When the [Device Lock] setting is activated, the Reader will not be recognized by your computer, please set to [Off] before connecting.

## [Standby Screen]

Sets the standby screen during the sleep mode. [Off] displays nothing in the sleep mode.

- [Show picture]: Set [On] to show the selected pictures on the standby screen. For details on setting the pictures, see “To set as a standby screen” (☎ [84](#)).
- [Show message]: Set [On] to show messages on the standby screen.

## **[Initialization]**

### **[Restore Defaults]**

Restores the Reader to its default settings. You will need to perform the initial settings after restoring.

### **[Clear Keyboard History]**

Deletes predictive words for the on-screen keyboard.

### **[Format Memory]**

Formats the internal memory of the Reader or an inserted memory card. Formatting will erase all the contents in the selected storage.

#### **Note**

Before formatting, make sure to backup data you wish to keep to your computer via Reader Library. Note that protected content will also be deleted by formatting.

# [Wireless Controls]

## [Mobile Network]

### [Wi-Fi]

Sets mobile network and Wi-Fi to on/off individually. When setting to [OFF], selected network is always disabled. [ON] is set by default. Tap [OK] to apply the change.

#### Note

Neither [Mobile Network] nor [Wi-Fi] cannot be set to [OFF]. If you want to disconnect from the connection of both mobile network and Wi-Fi, set the WIRELESS switch to OFF.

## [Wireless Standby]

Wireless standby helps avoid unnecessary battery consumption caused by wireless communication. [ON] is set by default.

If you do not perform any wireless operations for more than 10 minutes, the wireless feature automatically enters standby mode. During standby mode, you can receive periodicals while minimizing the battery consumption.

Tap [OK] to apply the change.

#### Notes

- Accessing the Reader Store from the wireless standby mode takes more time than accessing when the Reader is connected to the wireless network.
- If you deactivate wireless standby, the Reader retains wireless connection at all times, resulting in higher battery consumption.

## [Wi-Fi Network Settings]

The [Wi-Fi Network Settings] screen can be displayed from the following two screens.

- Tap [Continue with Wi-Fi Setup] at [Wi-Fi-Set-up] screen (☞ xx).
- Tap [Wi-Fi Network Settings] at [Settings] menu.

On the [Wi-Fi Network Settings] screen, registered access points and access points that are installed within the communication range of the Reader are displayed in a list.

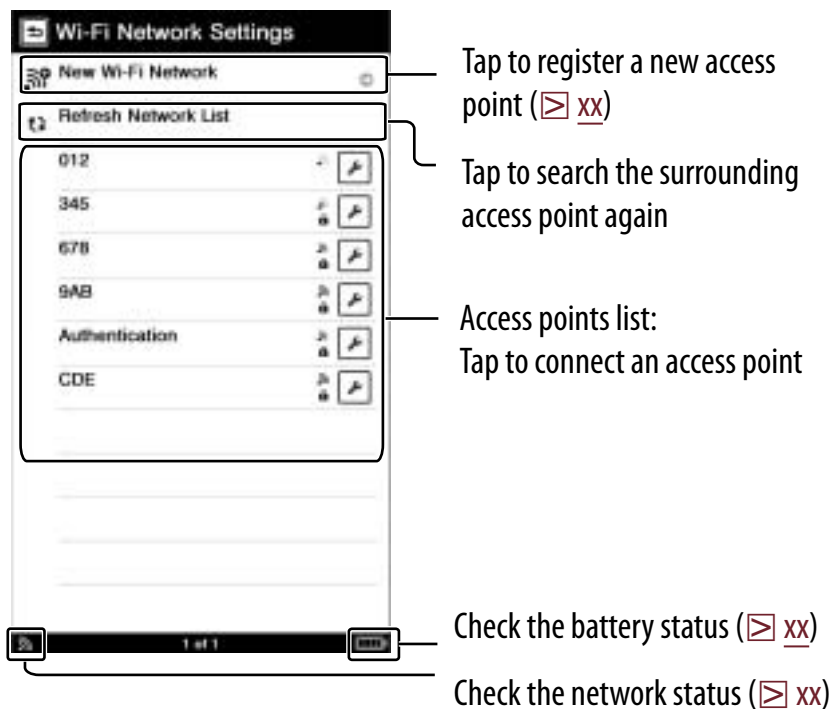

## 1 Tap the access point you want to connect to from the access points list.

If an encryption key is required, the detailed screen appears.

When no encryption key is required, the Reader connects to the selected access point. A check mark and [Connected] appears to the access point.



Tap to enter the encryption key

## 2 Tap [Key] → enter the encryption key using the on-screen keyboard → tap [OK].

The Reader connects to the selected access point.

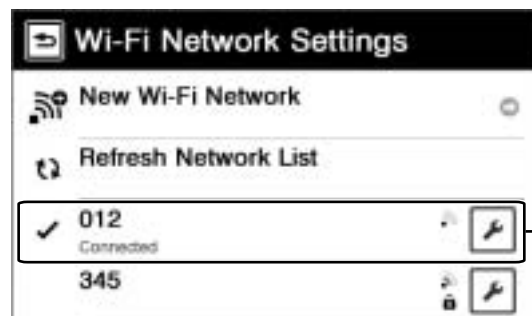

Connected access point

## Tips

- After registering, you can connect to the access point by simply selecting it from the [Wi-Fi Network Settings] screen.
- If you do not know the WEP key or WPA key for the access point, refer to the operation guide for the access point, or consult the administrator of the network or the public Internet access service provider.

## If you cannot connect

Some access points require more detailed settings. See “New Access Point” (☒ [xx](#)) to set up. If you are not sure about the settings, ask the person who installed the access point, the administrator of the Wi-Fi, or the public Internet access service provider.



## New Access Point

You can register or edit the access points displayed in a list. The access point not displayed in the access point list can also be registered.

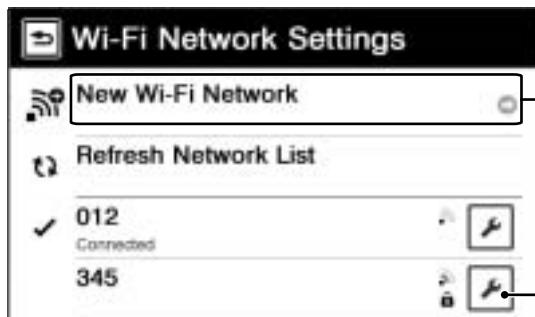

Tap to register a new access point (☞ xx)

Tap to display the detailed screen of the access point to register or edit the access point settings (☞ xx)

## Registering and editing the access point from the list

Tap  of the access point you want to set. The following items are displayed.

Item	Description
[Connection name:]	Enters the connection name using the on-screen keyboard ➔ tap [OK].
[SSID:]	Enters the SSID of the access point using the on-screen keyboard ➔ tap [OK].
[Encryption]	Tap the encryption method type of the access point ➔ tap [OK].
[Key:]	Enters the encryption key using the on-screen keyboard ➔ tap [OK].

Item	Description
[Wi-Fi Advanced Settings]	<p><b>[IP Address]:</b> Tap [Auto] to set the IP address automatically by using DHCP when the access point supports DHCP. To set the IP address manually, tap [Manual] ➔ a field to change. Input a number by tapping the numeric key pad ➔ tap [OK].</p> <p><b>[DNS]:</b> Enter the IP address of DNS Server by tapping the numeric key pad ➔ tap [OK].</p> <p><b>[Proxy]:</b> When the Wi-Fi you intend to connect to does not use a proxy server, tap [Off]. When using a proxy server, enter IP address and port number by tapping the numeric key pad ➔ tap [OK].</p>

### Note

When setting the IP address manually, it is necessary to set [DNS] manually. If the message dialog is displayed when tapping [Manual], tap [Yes].

When the setting of access point is completed, the registration complete dialog is displayed.

When connecting the Reader with the access point that finished being set, tap [Connect]. When not connecting, tap [Finish]. The [Wi-Fi Network Settings] screen is displayed.

## Registering a new access point not displayed in the list

Tap [New Wi-Fi Network] ➔ tap the desired setting method.

There are 3 way to register the access point. Set up following the instructions on the screen.

Item	Description
[WPS Push Button]	Connects to the WPS-compliant access point by using the push-button method.
[WPS PIN Input]	Connects to the WPS-compliant access point using the PIN method. Enter the PIN code of Reader (an 8-digit number) by tapping the numeric key pad ➔ tap [OK].
[Manual Input]	Allows you to enter the SSID manually. When the access point is set to hide the SSID, use this setting. Enter the SSID of the access point using the on-screen keyboard ➔ tap [OK]. When the detailed setting items are displayed, make the required settings (☑ <u>xx</u> ).

### Notes

- For information on the WPS settings of your access point, refer to the operation guide of the access point.
- After WPS setting for wireless LAN connection between the player and access point, the access point may become unconnectable to devices that were previously connected. For details, refer to the operation guide of the access point.

- For information on the settings of the access point, refer to the operation guide of the access point, consult the administrator of the access point, or consult the public Internet access service provider.
- You can register up to 32 access points.
- If you begin the new registration using the Push-Button or PIN method during connection to a wireless LAN, the connection will be terminated.

## OPTIONS menu of [Wi-Fi Network Settings]

Pressing the OPTIONS button (☰ xx) will display the menu for related supplementary functions.

When displaying the OPTIONS menu, not all items listed below will be shown in any given circumstance.

Item	Description/Reference page
[Delete Access Points]	Deletes the selected access point.
[Change Order]	<b>[Move to Top]:</b> Moves up the order of the selected access point in the list. <b>[Move to Bottom]:</b> Moves down the order of the selected access point in the list.
[Connection Information]	Displays the connection information of Wi-Fi network.

## Wi-Fi networks which may be used with Reader

Reader can connect to the following Wi-Fi.

- Your Home Wi-Fi
- Your office or school Wi-Fi
- Public Wi-Fi, such as at coffee shops, hotels, or libraries.

Standard	IEEE 802.11b IEEE 802.11g
Security	WEP (128 bit/64 bit, Open System Key) WPA-PSK (TKIP/AES) WPA2-PSK (TKIP/AES)
Communication range	Approx. 50m (160 ft) (The communication range may vary, depending on conditions of use and settings.)

### Notes

- To connect to an access point, the SSID and encryption key may be required. For the necessary settings (☒ xx), consult the person who installed the access point. For the settings of the access point, refer to the operation guide of the access point, or consult the manufacturer of the access point.
- For the necessary settings (☒ xx) to connect to a Wi-Fi, ask the administrator of the network (at office/school) or the public Internet access service provider.
- Reader does not support security systems customized in some access points. For details, refer to the operations guide for the access point.
- Reader does not support AOSS (AirStation One-Touch Secure System).

- Set the [Wi-Fi] option to [OFF] where the network connection is restricted or prohibited, such as in a hospital or in an airplane (▶ [xx](#)).
- Some public Wi-Fi services require log-in by using the Internet browser.

# Troubleshooting

If the Reader does not function as expected, try the following steps to resolve the issue.

- 1 Reset the Reader by pressing the RESET hole (☞ [10](#)) with a small pin or clip ➔ slide the power switch to restart the Reader.**

The content and settings stored on the Reader are not affected by resetting.

### Notes

- The bookmarks, highlights, handwritten memos, or the setting information may be deleted by resetting.
- The screen will not change after pressing the RESET hole. Slide the power switch to restart the Reader.
- Do not push the RESET hole with a breakable point, such as the graphite of a mechanical pencil. It causes the RESET hole to be blocked.

- 2 Check the symptoms list (☞ [97](#)).**

- 3 If it is an issue regarding Reader Library, check for information in Reader Library Help.**

- 4 Look for information on the support Web sites (☞ [18](#)).**

# Symptoms

## Power

### Battery cannot charge.

- Charge the battery within the temperature range of 41°F to 95°F (5°C to 35°C) (☒ 19).

### Battery life seems short.

- The operating temperature is below 41°F (5°C). This is due to the battery characteristics and not a malfunction.
- The Reader is discharged automatically even when not in use for a prolonged period. It is recommended that you charge the Reader again before turning on the Reader.
- The battery was not been given enough time to charge fully. Charge the Reader until the charge/busy indicator turns off. (The battery icon does not indicate remaining battery power during charging.)
- By sliding the power switch, the Reader enters standby mode in which the battery power is consumed slightly. To minimize battery consumption, before entering the sleep mode, slide and hold the power switch for more than 3 seconds to shut down the Reader.
-  in the status bar indicates the Reader is playing a track which consumes the battery power. Go to the playback screen and pause playback if necessary.
- When you are out of the network coverage area for a while, slide the WIRELESS switch to OFF (☒ xx). Battery life can be extended by turning off the wireless feature.



## The Reader cannot turn on.

- Moisture condensation may have occurred. Wait for a few hours and then turn on the Reader.
- Battery power has been fully depleted. Charge the Reader by connecting to the computer via the supplied USB cable (☒ [12](#)).

## Screen

### Display takes a long time to appear.

- In a cold place such as outdoors, it may take time for the display to appear. This is due to the display characteristics and not a malfunction.
- It may take a few moments for the Reader start-up screen to appear after a reset or shutdown.

### The screen is frozen.

- Reset the Reader by pressing the RESET hole. Then, slide the power switch to turn on the Reader again (☒ [8](#)).

### Touch operation is not effective.

- If condensation occurs in the touch screen, or dust attaches to the touch screen, it may cause a malfunction. For details, see “On Cleaning” (☒ [xx](#)).
- If any objects are placed on the touch screen, it may cause a malfunction. When not in use, leave the Reader in sleep mode, or shut it down.

### A page in the Reader Store is not displayed properly.

- The wireless connection may have been interrupted. Make sure the WIRELESS switch is set to “ON” and a wireless network is available (☒ [xx](#)), then refresh the page using [Refresh Page] in the OPTIONS menu (☒ [xx](#)).

## Wireless feature

### You cannot access the Reader Store.

- You are out of the network coverage area. To check the wireless status, see the wireless status icon in the status bar (☰ [xx](#)).

### You cannot find a purchased book on the Reader.

- The wireless connection may have been interrupted while you were downloading the book. Go to the [My Account] page in the Reader Store to re-download the book.

### You have received the latest periodical

- The Reader may have been outside the network coverage area when the issue was delivered. Go to the [My Account] page in the Reader Store to re-download the past issue(s).

### Tip

If you cannot find a solution from the above, go to [Help and Support] from the OPTIONSn menu in the Reader Store (☰ [xx](#)).

## Reading contents

### A book cannot be read.

→ If the book has an expiration date, confirm whether the book has already been expired (☒ [37](#)).

### A book that has been transferred from your computer cannot be read.

- Either the Reader, your computer, or both may not have been authorized. Via Reader Library, go to the [My Account] page in the Reader Store and authorize the Reader and your computer.
- You may have tried to read the content owned by another user. The content owned by another user may not have been authorized.
- The authorization data may have been damaged as a result of shutting down while reading a content. De-authorize your computer and the Reader, then authorize again via Reader Library. Refer to Reader Library Help for further information.
- The book may be protected by unsupported digital rights management. Check the book source for compatibility.
- The book may contain an unsupported file format. Check the file format compatibility (☒ [121](#)).

### [Continue Reading] does not work, or bookmarks are missing.

- If the file status has changed (such as in the following cases), data on [Continue Reading] or notes may be deleted.
  - A Text/RTF/PDF file is edited.
  - A book purchased with an authorized Reader is read on another de-authorized Reader by memory card transfer.

## **You cannot find a transferred book.**

- Protected content on the Reader can be deleted if it is deleted from your computer after being connected. It is recommended to manage content using Reader Library.
- Books being transferred to the Reader by synchronization are deleted automatically if the same books are deleted in Reader Library before synchronization. For details, refer to Reader Library Help.
- Do not delete folders or files from any of the “database” folder in the Reader. The content or notes may be deleted.

## **Playing audio files**

### **An audio file cannot play back.**

- Audio files that are not supported by the Reader cannot be played. For details on supported audio files, see “Supported File Formats” (☒ [121](#)).

### **Sound output is not audible.**

- Increase the volume if it is set to low (☒ [11](#)).
- If sound is not output through headphones, make sure the headphone plug is firmly inserted in the headphone jack (☒ [11](#)).

## **Viewing pictures**

### **A picture cannot be displayed.**

- Picture files that are not supported by the Reader cannot be viewed. For details on supported picture files, see “Supported File Formats” (☒ [121](#)).
- A large file size of picture may not be displayable, and its file will not appear in the list. Delete the picture file using Reader Library.

## Connection to the computer

### The Reader cannot be operated.

- The Reader cannot be operated when connected to a computer via USB.

### Reader cannot charge by your computer

- If [Charging stopped] is displayed on the screen, check the conditions to charge the Reader again (☒ [xx](#)). If charging the Reader by connecting to your computer, make sure your computer is powered on.

### The Reader cannot be recognized by your computer.

- A USB hub or USB extension cable is used for the connection. Connection via an extension cable or USB hub is not guaranteed. Connect the USB cable directly to the computer.
- Disconnect the USB cable from the Reader, then reconnect it after a while.
- If the Reader is locked, it will not be recognized by your computer, set [Device Lock] to [Off] (☒ [93](#)).
- While the Reader is connected to a computer, do not turn on, restart, wake up from sleep mode, or shut down the computer. These operations may influence the Reader unrecognizable by the computer. Disconnect the Reader from the computer before performing these operations.
- Use the supplied USB cable.
- There may be a malfunction with the USB port on your computer. Connect the supplied USB cable to another port on the computer.
- It may take a while for the software to be recognized by the computer. Wait for a moment.
- If none of the above solves the problem, press the RESET hole of the Reader (☒ [96](#)), turn on the Reader again, and then reconnect the supplied USB cable.

**Content cannot be transferred to the Reader from your computer.**

- There is not enough free space on the Reader memory. Check [About] (☒ [89](#)) for free space on internal memory, then delete unnecessary data.
- The Reader is not authorized. Authorize the Reader using Reader Library. Refer to “Authorizing Your Computer and the Reader Device for eBook Stores” in Reader Library Help.

**Reader Library does not recognize the Reader.**

- Disconnect the USB cable from the Reader, then reconnect it.

**The Reader becomes unstable while connected to a computer.**

- A USB hub or USB extension cable is used for the connection. Connection via an extension cable or USB hub is not guaranteed. Connect the USB cable directly to the computer.

**Memory Card**

**Content on a memory card cannot be read/played/viewed on the Reader.**

- Check that the memory card is inserted in the media slot in the correct direction (☒ [9](#)).
- Check to see that you are using a memory card that is supported by the Reader (☒ [114](#)).
- Clean the terminal area of the memory card gently with a soft cloth if it is dirty (☒ [114](#)).
- The Reader is not authorized, refer to “Authorizing Your Computer and the Reader Device for eBook Stores” in Reader Library Help.

- When inserting the memory card into the Reader, it may take time for the Reader to recognize the content files in the memory card especially if the number of the content files stored on the memory card is large.

**Content cannot be transferred to a memory card.**

- Unlock the erasure prevention switch if it is locked.
- There is not enough free space on the memory card. Check [About] (☒ [89](#)) for free space on the memory card, then delete unnecessary data (☒ [74](#)).
- The Reader cannot transfer content to memory cards directly. Use Reader Library to transfer content.

**A memory card cannot be recognized on the Reader or Reader Library.**

- If a memory card is formatted by your computer, it may become unusable on the Reader and Reader Library. When formatting a memory card, format it using the Reader (☒ [95](#)).

**Content on a memory card cannot be deleted.**

- Unlock the erasure prevention switch if it is locked.
- Uncheck the read-only attribute of content from your computer.

## SIM card

If the following message is displayed: “Your SIM card is not recognized. Please shut down your Reader, re-insert your SIM card and turn your Reader back on.”

→ Re-insert a SIM card according to the following procedure.

**1** Press the hole of SIM card with a small pin or clip.

Hole of a SIM card

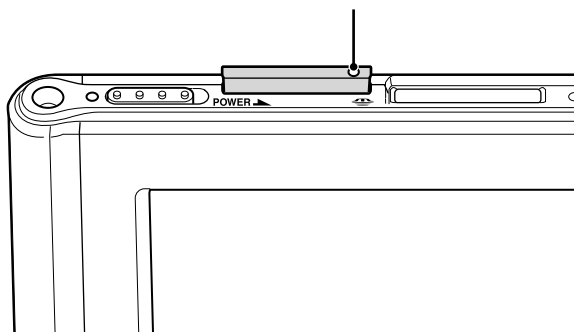

**2** Pull out the SIM card from the Reader.

SIM card

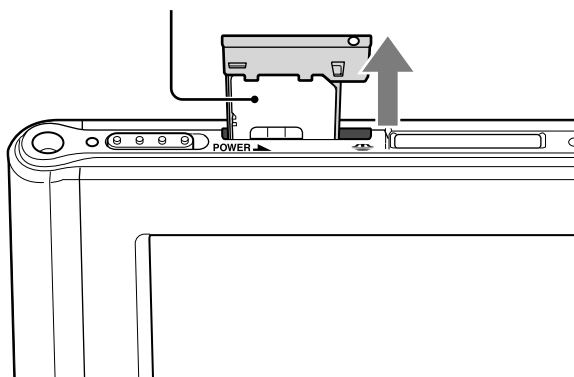

**3** Insert a SIM card to the Reader again.



# Precautions

### Reader Disposal Reference

The built-in rechargeable battery of the Reader is recyclable. Do not remove the battery yourself, consult Sony Support Center (☎ [18](#)).



### **Disposal of Old Electrical & Electronic Equipment (Applicable in the European Union and other European countries with separate collection systems)**

This symbol on the product or on its packaging indicates that this product shall not be treated as household waste. Instead it shall be handed over to the applicable collection point for the recycling of electrical and electronic equipment. By ensuring this product is disposed of correctly, you will help prevent potential negative consequences for the environment and human health, which could

otherwise be caused by inappropriate waste handling of this product. The recycling of materials will help to conserve natural resources. For more detailed information about recycling of this product, please contact your local Civic Office, your household waste disposal service or the shop where you purchased the product. Applicable accessories: AC Adapter (PRSA-AC1)

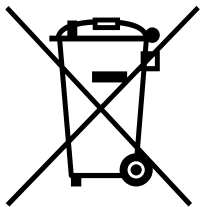

**Disposal of waste batteries (applicable in the European Union and other European countries with separate collection systems)**

This symbol on the battery or on the packaging indicates that the battery provided with this product shall not be treated as household waste. On certain batteries this symbol might be used in combination with a chemical symbol. The chemical symbols for mercury (Hg) or lead (Pb) are added if the battery contains more

than 0.0005% mercury or 0.004% lead.

By ensuring these batteries are disposed of correctly, you will help prevent potentially negative consequences for the environment and human health which could otherwise be caused by inappropriate waste handling of the battery. The recycling of the materials will help to conserve natural resources.

In case of products that for safety, performance or data integrity reasons require a permanent connection with an incorporated battery, this battery should be replaced by qualified service staff only.

To ensure that the battery will be treated properly, hand over the product at end-of-life to the applicable collection point for the recycling of electrical and electronic equipment.

For all other batteries, please view the section on how to remove the battery from the product safely. Hand the battery over to the applicable collection point for the recycling of waste batteries.

For more detailed information about recycling of this product or battery, please contact your local Civic Office, your household waste disposal service or the shop where you purchased the product.

**Notice for customers: the following information is only applicable to equipment sold in countries applying EU directives**

The manufacturer of this product is Sony Corporation, 1-7-1 Konan, Minato-ku, Tokyo, 108-0075 Japan. The Authorized Representative for EMC and product safety is Sony Deutschland GmbH, Hedelfinger Strasse 61, 70327 Stuttgart, Germany. For any service or guarantee matters please refer to the addresses given in separate service or guarantee documents.

**FCC Compliance Statement:**

The following FCC statement applies only to the version of this model manufactured for sale in the USA.

Other versions may not comply with FCC technical regulations.

NOTE: This equipment has been tested and found to comply with the limits for a Class B digital device, pursuant to Part 15 of the FCC Rules. These limits are designed to provide reasonable protection against harmful interference in a residential installation. This equipment generates, uses and can radiate radio frequency energy and, if not installed and used in accordance with the instructions, may cause harmful interference to radio communications.

However, there is no guarantee that interference will not occur in a particular installation. If this equipment does cause harmful interference to radio or television reception, which can be determined by turning the equipment off and on, the user is encouraged to try to correct the interference by one or more of the following measures:

- Reorient or relocate the receiving antenna.
- Increase the separation between the equipment and receiver.
- Connect the equipment into an outlet on a circuit different from that to which the receiver is connected.
- Consult the dealer or an experienced radio/TV technician for help.

You are cautioned that any changes or modifications not expressly approved in this manual could void your authority to operate this equipment.

**FCC Radiation Exposure Statement:**

This equipment complies with FCC radiation exposure limits set forth for an uncontrolled environment. This device is designed for hand-held operation only. This transmitter must not be co-located or operating in conjunction with any other antenna or transmitter except those transmitters that are factory installed.

**If you have any questions about this product:**

**Visit:**

www.sony.com/readersupport

**Contact:**

Sony "Digital Book Reader" Customer Support at  
1-(866)-962-7669

**Write:**

Sony Customer Information Service Center  
12451 Gateway Blvd., Fort Myers, FL 33913

**Declaration of Conformity**

Trade Name: SONY  
Model No.: PRS-950  
Responsible Party: Sony Electronics Inc.  
Address: 16530 Via Esprillo, San Diego, CA 92127 U.S.A.  
Telephone Number: 858-942-2230

This device complies with Part 15 of the FCC Rules. Operation is subject to the following two conditions: (1) this device may not cause harmful interference, and (2) this device must accept any interference received, including interference that may cause undesired operation.

**For customers in the USA and Canada**

**RECYCLING LITHIUM-ION BATTERIES**

Lithium-ion batteries are recyclable.

You can help preserve our environment by returning your used rechargeable batteries to the collection and recycling location nearest you. For more information regarding recycling of rechargeable batteries, call toll free 1-800-822-8837, or visit <http://www.rbcc.org/>.

**Caution:** Do not handle damaged or leaking Lithium-ion batteries.



## Safety Information

- A SIM card is factory installed. If you take it out, the wireless feature becomes unavailable.
- Use the supplied AC adapter (PRSA-AC1) only. Do not use other AC adapter.
- Recorded content is limited to private use only. Use of the content beyond this limit requires permission of the copyright holders.
- Sony is not responsible for incomplete recording/downloading or damaged data due to problems of the Reader or computer.
- Be sure not to short-circuit the terminals of the Reader with metallic objects.
- If part of the device that generates heat contacts your skin for a prolonged period, you may suffer from symptom of burn, such as redness, swelling, even if temperature is moderate. Avoid prolonged contact, especially if you have sensitive skin.
- Replacement or repair for concerning damage and the crack which are in the midst of using is not covered by warranty.
- Please do not drop, do not add excessive power.
- Never subject the Reader to extremes of light, temperature, moisture or vibration.
- Never wrap the Reader in anything when it is being used with the AC adapter. Heat build-up in the Reader may cause malfunction or damage.
- Do not put any heavy object on top of the Reader or apply a strong shock to the Reader. It may cause a malfunction or damage.
- Do not leave the Reader on an unstable surface.
- Do not expose the Reader to water. The Reader is not waterproof.
- Remember to follow the precautions below.
  - Be careful not to drop the Reader into a sink or other container filled with water.
  - Do not use the Reader in humid locations or bad weather, such as in the rain or snow.
  - Do not get the Reader wet.
    - If you touch the Reader with wet hands, or put the Reader in a damp article of clothing, the Reader may get wet and this may cause a malfunction.
- The screen is delicate and subject to cracking. Handle the Reader with care.
- Do not poke people using the supplied stylus.
- Do not treat or use the supplied stylus roughly, such as bending it, or scratching the touch screen with it.
- Use the supplied stylus only for touch screen operations.
- Do not use the stylus if it is damaged or deformed.
- Do not put any cards such as cash cards or credit cards with magnetic coding near the magnet stored in the Reader. Otherwise, your cards may become impaired due to the magnetic effect.
- If any objects are placed on the touch screen, it may cause a malfunction. When not in use, leave Reader in sleep mode, or shut it down.

### On heat build-up

Heat may build up in the Reader while charging, or if it is used for an extended period

of time.

## **On the headphone**

### **Road Safety**

Do not use headphones while driving, cycling, or operating any motorized vehicle. It may create a traffic hazard and is illegal in many areas. It can also be potentially dangerous to play at a high volume while walking, especially at pedestrian crossings. You should exercise extreme caution or discontinue use in potentially hazardous situations.

### **Preventing hearing damage**

Avoid using the headphones at a high volume. Hearing experts advise against continuous, loud and extended play. If you experience a ringing in your ears, reduce the volume or discontinue use.

### **Caring for others**

Keep the volume at a moderate level. This will allow you to hear outside sounds and to be considerate to the people around you.

### **Warning**

If lightning occurs while you are using the Reader, take off the headphones immediately.

**On the wireless feature**

- SONY provides wireless connectivity at no additional cost to you for certain activities in connection with the content service provided by SONY. You may be charged a fee for wireless connectivity for your use of other wireless services on your product, such as web browsing, should those services be available. You will be notified of the current fees for such services through the content service. SONY reserves the right to discontinue wireless connectivity at any time or to otherwise change the terms of service for wireless connectivity at any time, including but not limited to the amount and terms applicable for wireless connectivity charges. SONY reserves the right to limit the number and size of data files that may be transferred using the wireless connectivity. You agree that you will only use the wireless connectivity provided by SONY in connection with the content service that SONY provides for your product. You may not use the wireless connectivity for any other purpose. Your use of the wireless connectivity may be limited if your product is located in any area without applicable wireless service coverage, and you may not be able to use some or all of the wireless services, including the content service. SONY is not responsible for the unavailability of wireless connectivity or any interruptions of wireless service.
- Wireless connectivity is only available in the USA, within the service coverage area. Connectivity may vary.
- Turn off the wireless feature outside the USA. Do not use wireless feature in other countries.
- Turn off the wireless feature when you are in a location in which radio communications are prohibited. When you are in such a location, you must obtain permission from the appropriate authorities before enabling the wireless feature of this device.
- Turn off the wireless feature in health care facilities where any regulations posted in such areas instruct you to do so. Hospitals or health care facilities may be using equipment that could be effected by radio frequency (RF) energy which is generated by wireless communication.
- Federal Aviation Administration (FAA) and Federal Communications Commission (FCC) regulations prohibit using the radio of wireless devices while in the air. Turn off the wireless feature before boarding an aircraft.
- Do not use your Reader near medical equipment without first obtaining permission to do so.
- If you use any personal medical device, consult the manufacturer of your device to determine whether it may be affected by RF energy.

**On software**

- Copyright laws prohibit reproducing the software or the manual accompanying it in whole or in part, or renting the software without the permission of the copyright holder.
- In no event will SONY be liable for any financial damage, or loss of profits, including claims made by third parties, arising out of the use of the software

supplied with this Reader.

- The software provided with this Reader cannot be used with equipment other than that which is so designated.
- Please note that, due to continued efforts to improve quality, software specifications may be changed without notice.
- Operation of this Reader with software other than that provided is not covered by the warranty.
- Depending on the types of the text and characters, the text shown on the Reader Library may not be displayed properly on device. This is due to:
  - The capacity of the Reader.
  - The Reader is not functioning normally.
  - Content information is written in the language or the character that is not supported by the Reader.
- The ability to display the languages on your Reader Library will depend on the OS installed on your computer. For better results, please ensure that the installed OS is compatible with the desired language you want to display.
  - We do not guarantee all the languages will be able to be displayed properly on your Reader Library.
  - User-created characters and some special characters may not be displayed.
- Explanations in this manual assume that you are familiar with the basic operations of Windows or Mac OS. For details on the use of your computer and operating system, please refer to the respective manuals.
- By updating the Reader device software, you can ensure your Reader has the latest features. The latest software updates can be performed from the update menu on Reader Library Help – “Check for Updates”.

### **About Pre-loaded Contents**

Sample content is pre-installed in the Reader so that you can try them out right away. The pre-installed sample content is for the purpose of trial reading, viewing and listening.

#### **Note**

- If you delete pre-installed sample content, you cannot restore it, and Sony will not supply any replacement content.



## On cleaning

- Clean of the Reader with a soft cloth, such as a cleaning cloth for eyeglasses.
- If of the Reader becomes very dirty, clean it with a soft cloth slightly moistened with water or a mild detergent solution.
- Do not use any type of abrasive pad, scouring powder, or solvent, such as alcohol or benzene, as it may mar the finish of the case.
- In order not to get wet to the water, paying attention.
- Clean the headphone plug periodically.
- Tapping or dragging on the touch screen using a dirty stylus may damage the surface. Wipe the stylus with a dry cloth when it gets dirty.

## Notes on memory cards

Remove the memory slot protective card before inserting a memory card (optional). You can use the following memory cards with the Reader.

<b>Memory Stick Duo™ media</b>	Memory Stick Duo™ Memory Stick PRO Duo™ Memory Stick PRO-HG Duo™ Memory Stick Micro™
<b>SD Card</b>	SD Card SDHC Card

## About Memory Stick Duo™ media

Memory Stick Duo™ is a compact-size IC recording media with a large capacity. It has been designed not only for exchanging/sharing digital data among Memory Stick Duo™ compliant products, but also for serving as a removable external storage media that can save data.

### Notes

- Sony's Memory Stick Duo™ media of up to 32 GB has been tested to work with the Reader. But the proper operation on all types of the Memory Stick Duo™ media is not guaranteed.
- SD card of up to 32 GB has been tested to work with the Reader; however, not all SD cards are guaranteed to work.
- The M2™ Duo-size adapter must be attached to use Memory Stick Micro™ media in a slot for Memory Stick Duo™ media.
- The file system incorporated in the Memory Stick™ limits the capacity of a file to be transferred to less than 4GB.
- Data over 123MB cannot be recorded in a single session.
- Standard-size Memory Stick™ media cannot be used on this product
- The maximum number of songs that can be recorded in the Memory Stick PRO™ media is 65535.

## About SD card

SD card complies with compact memory card standard and is commonly used as a storage media for digital still cameras.

**Notes on handling memory cards**

- Insert into the correct slot with the card's label side up until it clicks into place.
- The Reader does not comply with the following:
  - MagicGate™ standard\*.
  - copyright protection of SD cards.
- \* MagicGate™ is the collective name of content protection technologies developed by Sony.
- You cannot record or delete data stored in a memory card when its erasure prevention switch is locked.
- Keep a memory card in its case when you carry or store it.
- Do not touch the connector of a memory card with bare hands or metallic objects.
- Do not bend, drop, or subject a memory card to excessive shock.
- Do not disassemble or modify a memory card.
- Do not allow a memory card to get wet.
- Avoid the following to prevent data damage. Sony does not provide any guarantee for damaged data.
  - Do not remove a memory card or turn off the Reader while reading or writing data.
  - Do not operate the Reader in the location where static charge or electrical noise is present.
- Do not use a label other than the dedicated one in the label area.
- Do not use or store the Reader in a location subject to:
  - extreme high temperature, such as in a sun-heated car.
  - direct sunlight.
  - high humidity or places with corrosive substances.
- Do not insert an incompatible memory card, as it may cause malfunction.
- Do not use a deformed memory card or adapter.
- If you attempt to insert Memory Stick Micro™ media without attaching to an M2™ Duo-size adapter, it may become jammed.
- Do not remove a memory card from the media slot while data on the memory card is being edited. Otherwise, edited data will not be saved.
- Keep both memory cards and adapter out of reach of small children, to avoid accidental swallowing.
- If a format process is executed, all the files, even including write-protected image files, will be deleted.
- We recommend that important data be backed up. If you change or erase a folder name via PC, or move file to a folder other than "database", there is a possibility that data recorded in a memory card might be lost or become unplayable by this product.

# Copyright Notice

The contents of each book pre-loaded on this product are copyrighted works, edited with the cooperation of the publisher. Copyright laws prohibit copying the data of this product or the contents of this manual (illustrations, related documents, etc.) in whole or in part without the permission of the copyright holder. Additionally, use of the data of this product or the contents of this manual is not allowed without Sony's permission except for personal use.

Besides individually enjoying, it is against the copyright law to use any audio or picture you recorded without prior consent of the copyright holder. Accordingly, Memory Stick™ media with content protected image or data can be only used within the law.

- Sony, the Sony logo, "BBEB", "Reader", "Reader Daily Edition" and their logos are either trademarks or registered trademarks of Sony Corporation.



**MEMORY STICK™**, "Memory Stick", "Memory Stick PRO Duo", "Memory Stick PRO-HG Duo", "Memory Stick Duo", "Memory Stick Micro", "M2", "MagicGate" and their logos are trademarks of Sony Corporation.

- Bitstream is a registered trademark, and Dutch, Font Fusion, and Swiss are trademarks, of Bitstream Inc.
- Microsoft, Windows, Windows Vista and Windows Media are trademarks or registered trademarks of Microsoft Corporation in the United States and / or other countries.
- Macintosh and Mac OS are trademarks of Apple Inc., registered in the U.S. and other countries.
- This PRS-950 contains Adobe® Reader® Mobile software under license from Adobe Systems Incorporated, Copyright © 1995-2009 Adobe Systems Incorporated. All rights reserved. Adobe and Reader are trademarks of Adobe Systems Incorporated.
- MPEG Layer-3 audio coding technology and patents licensed from Fraunhofer IIS and Thomson.
- This product includes software developed by the OpenSSL Project for use in the OpenSSL Toolkit. (<http://www.openssl.org/>) Copyright© 1998-2008 The OpenSSL Project. All rights reserved. This product includes cryptographic software written by Eric Young (eay@cryptsoft.com). This product includes software written by Tim Hudson (tjh@cryptsoft.com). For details on OpenSSL License, refer to "END USER LICENSE AGREEMENT" in [About] at [Settings] menu on the Reader.

All other system names and product names appearing in this document are the registered trademarks or trademarks of their respective owners. Further, the trademark™ and registered trademark® symbols are not indicated throughout this

document.

Program ©2010 Sony Corporation

Documentation ©2010 Sony Corporation

# GNU GENERAL PUBLIC LICENSE

This product contains the following software covered by the GNU General Public License (hereinafter referred to as "GPL") and/or GNU Lesser General Public License (hereinafter referred to as "LGPL").

You may obtain, alter, and redistribute the source code of these software products.

busybox  
dosfstools  
freetype  
intiscripts  
kernel  
linux-kernel-headers  
make  
MAKEDEV  
modules  
mtd  
nandboot  
procps  
procps  
sourceryg++  
tar  
udev  
util-linux

For the terms and conditions concerning GPL and LGPL, please refer to below. The source code for these software products is available on Sony's website. To download, please visit the following URL: <http://www.sony.net/Products/Linux/> Please note that Sony accepts no inquiries concerning the content of the source code.

For details on GNU GENERAL PUBLIC LICENSE, refer to "END USER LICENSE AGREEMENT" in [About] at [Settings] menu on the Reader.

# Supported File Formats

The following file formats can be managed within Reader Library and transferred to your Reader.

## **Book**

- EPUB file (.epub file extension)  
EPUB (OPS version 2.0) supported
- PDF file (.pdf file extension)  
Support is based on the PDF 1.6 specification.
- BBeB (.lrf or .lrx file extension)
- Text file (.txt file extension)
- RTF file (.rtf file extension)
- Word file (.doc or .docx file extension)\*

\* In case of using Windows, you need Microsoft Word installed on your computer. Word files will be automatically converted to RTF files by Reader Library during transfer to your Reader or a compatible memory card.

## **Audio**

- MP3 file (.mp3 file extension)  
The following specifications should be met in order to import an MP3 file.
  - Bit rate: 32 to 320 kbps
  - Sampling frequency: 22.05, 44.1 kHz
  - File must be unsecured.
- AAC file (.mp4, .m4a, .mov, or .qt file extension)  
The following specifications should be met in order to import an AAC file.
  - Bit rate: 40 to 320 kbps
  - Sampling frequency: 24.0, 44.1, 48.0 kHz
  - File must be unsecured.

## **Picture**

- JPEG file (.jpg or .jpeg file extension)
- GIF file (.gif file extension)\*
- PNG file (.png file extension)
- BMP file (.bmp file extension)

\* For an animation GIF file, only the first frame will be shown.

### **Note**

A large file size of picture may not be displayable, and its file will not appear in the list. Delete the picture file using Reader Library.

# System Requirements

Reader Library will work with the following operating systems.

<b>OS</b>	<b>Description</b>
Microsoft Windows 7 (32/64 bit)	Windows 7 Starter Windows 7 Home Basic Windows 7 Home Premium Windows 7 Professional Windows 7 Ultimate
Microsoft Windows Vista (32/64 bit)	Windows Vista Home Basic with Service Pack 2 or later Windows Vista Home Premium with Service Pack 2 or later Windows Vista Business with Service Pack 2 or later Windows Vista Ultimate with Service Pack 2 or later
Microsoft Windows XP (32 bit only)	Microsoft Windows XP Home Edition with Service Pack 3 or later Windows XP Professional with Service Pack 3 or later Windows XP Media Center Edition 2004 & 2005 with Service Pack 3 or later
Apple Macintosh (32 bit only)	Mac OS X version 10.6.3 or later Mac OS X version 10.5.8 or later Mac OS X version 10.4.11 or later

















CPU	Windows: 800 MHz Celeron class processor or better Macintosh: Intel, PowerPC G3, G4 or G5 processor
RAM	128 MB or more (minimum 512 MB for Windows 7, Windows Vista)
Free space on hard disc	Windows: 100 MB or more Macintosh: 60 MB or more Depending on the content amount, more space may be required.
Monitor	High Color or more, 1024 × 768 pixels or more (True Color, 1280 × 1024 pixels, or more recommended)
Other devices	USB port (High-Speed USB Compatible), pointing device such as mouse or track pad

- Internet connection (broadband recommended, some fees may apply) is also required on your computer.
- Reader Library is not supported by the following environments:
  - An operating system other than those included above
  - Personally built computer or operating system
  - Multi-boot environment
  - Multi-monitor environment

# Index

## Symbols

 (Home) button.....	10, 29
OPTIONS button .....	10, 31
 (Page Turn) buttons.....	10
 (Size) button.....	10, 47, 84
 [All Notes] .....	29, 46
 [Applications] .....	29, 76
 [Audio] .....	76, 85
 [Books] .....	29, 36
 [Collections] .....	29, 68
 [Dictionary].....	76, 82
 [Handwriting] .....	76, 77
 [Home].....	29
 [Periodicals].....	29, 65
 [Pictures] .....	76, 83
 [Settings].....	29, 88
 [Text Memo].....	76, 80
[2-Column Split].....	48
[3-Column Split].....	48

## A

About the User Guide .....	22
Adding a note .....	42
Adding contents .....	70
Adjusting Content View ....	52
All Notes.....	29, 46

Annotation.....	39
Appendix.....	106
Applications .....	76
Applications menu.....	76
Audio .....	85, 122
[About] .....	89
[Add] .....	31, 69
[Add Bookmark].....	31, 39
[Add to Collection].....	31, 71
[Adjust View] .....	31, 52
[Applications Preference]	.....88, 91

## B

Basic Operation.....	22
Battery status .....	13, 30
Bookmarking .....	39
Books .....	36
[Brighter].....	52
[Books] list.....	36
Conditional icon.....	37
Sort.....	36, 34
[Search].....	34
[Sort] .....	34
[View] .....	34

## C

Changing a page mode ....	48
Changing dictionary	.....31, 60, 91

- Charge/Busy indicator ..... 8, 12
- Charging the Reader ..... 12
- Battery status..... 13
- Charge/Busy indicator ..... 8, 12
- Status indicators during charging ..... 13
- USB connector ..... 11, 12
- Changing Settings .....88
- Collections .....29, 68
- Conditional icon .....37
- Copyright Notice ..... 117
- Creating a collection .....68
- Creating drawings.....77
- Creating text memos .....80
- [Change Dictionary] ....31, 61
- [Clear Keyboard History] .....89, 95
- [Continue Reading].....31
- [Create/Edit] .....33, 41
- [Custom] .....52, 53
- D**
- Default settings.....95
- [Restore Defaults]....89, 95
- Deleting a collection .....72
- Deleting Content.....74
- Dictionary.....60, 82, 91
- Changing dictionary .....31, 60, 91
- [Word Logs: Dictionary] .....35, 64
- Drawing .....41, 42, 77
- [Darker] .....52
- [Date and Time].....90
- [Date and Time Format] ....90
- [Delete Audio].....32
- [Delete Book] .....31, 74
- [Delete Books] .....31, 74
- [Delete Collections] ....31, 72
- [Delete Drawing] .....31, 79
- [Delete Drawings].....31, 79
- [Delete Issue] .....31
- [Delete Issues].....32
- [Delete Memo].....31, 81
- [Delete Memos].....32, 81
- [Delete Notes].....32
- [Delete Pictures].....32
- [Delete Word Logs] .....32, 64
- [Details] .....52
- [Device Lock].....88, 93
- [Device Shutdown] .....90
- [Dictionary].....91
- E**
- eBook store ..... 17

**F**

Features .....	4
Finding a Note .....	44
Annotation .....	39
Icons and types of note in the [Notes] list .....	45
Finding the notes in all contents .....	46
[Format Memory] .....	89, 95
[Full Page].....	48

**G**

Getting Started.....	8
GNU GENERAL PUBLIC LICENSE.....	119
[General Settings].....	88, 90
[Go to].....	32, 57, 59
[History].....	32, 59
[Previous View].....	32, 59
[Select Page] .....	32, 57
[Table of Contents] .....	32

**H**

Handwriting .....	41, 42, 76, 77
Finding a Note.....	44
[Notes].....	33, 41, 44
Handwriting a note.....	41
Headphone jack.....	13
Highlighting words.....	40

Holes for cover attachment .....	11
Home Menu.....	29
How to Get eBooks .....	17
[Hide]/[Show].....	33
[History] .....	32

**I**

Icons and types of note in the [Notes] list.....	45
Issues.....	66, 71
[Info].....	32
[Initialization] .....	89, 95

**J**

Jumping to a Page .....	57
Link.....	22, 59
[Go to] .....	32, 57, 59
[Previous View].....	32, 59
[Select Page] .....	32, 57

**K**

[Keyboard] .....	88, 91
------------------	--------

**L**

Link .....	22, 59
Listing previously looked up words.....	63
[List].....	33, 44

**M**

- Magazines .....29, 65
- Memory card access
  - indicator ..... 9
- Media slot..... 9
- Memory card.....9, 113
- Memory Stick PRO Duo™
  - .....9, 113
- Memory Stick PRO Duo™
  - slot..... 9
- [Margin Cut] .....48
- [Menu Language].....90

**N**

- Newspapers.....29, 65
- Note.....39, 42, 44
  - Annotation .....39
  - Bookmarking .....39
  - Drawing .....41, 42
  - Finding a Note.....44
  - Handwriting a note .....41
  - Highlighting words .....40
  - [Notes].....33, 41, 44
- [New Collection] .....33, 68
- [New Drawing] .....33, 77
- [New Memo].....33, 80
- [Notes] .....33, 41, 44
  - [Create/Edit] .....33, 41
  - [Hide]/[Show] .....33

- [List] .....33, 44
- [Now Playing].....33, 86

**O**

- On-screen keyboard.....26
  - [Clear Keyboard History]
    - .....89, 95
  - [Keyboard] .....88, 91
- Operation at book page....38
- OPTIONS Menu .....29
- [Orientation].....33, 54
- [Original].....48, 52

**P**

- Parts and Controls..... 8
- Periodicals.....29, 65
- Pictures.....76, 83
  - Slideshow.....34, 83, 91
  - Standby screen
    - .....34, 84, 94
  - Supported file format
    - .....120
  - Zooming in.....49, 84
- [Select Standby Screen]
  - .....34, 84
- [Slideshow On]/
  - [Slideshow Off] .....34, 83
- [Slideshow].....88, 91
- [Standby Screen] .....88, 94
- Playing audio files .....85

Power saving Tips.....	14
Power management....	88, 92
Charging the Reader....	12
Power saving Tips.....	14
Power switch.....	8
Standby screen	
.....	34, 88, 94
[Device Shutdown].....	89
Power switch.....	8
Charging the Reader....	12
Standby screen	
.....	34, 84, 94
[Device Shutdown].....	89
Precautions.....	106
Protecting Content .....	75
Conditional icon .....	37
[Page Mode] .....	44
[Page Turn Preference].....	90
[Power Management]	
.....	88, 92
[Previous View]	
.....	32, 33, 59, 62
[Protect Audio] .....	33
[Protect Books] .....	33, 75
[Protect Drawings] .....	33, 79
[Protect Issues] .....	33
[Protect Memos] .....	33, 81
[Protect Pictures] .....	33

**R**

Reader Library .....	13
Reading Books.....	36
Reading Content.....	36
Reading Periodicals .....	65
Removing contents .....	78
Repeat .....	34, 87
Reset.....	96
RESET hole .....	11, 96
Resizing.....	47
[Remove Bookmark]....	34, 38
[Remove Content] .....	34, 73
[Rename Collection]....	34, 69
[Repeat].....	34, 87
[Resume Playing].....	34, 87
[Restore Defaults].....	89, 95
[Return to List] .....	34

**S**

Screen Orientation.....	55
Zoom-in mode .....	51
[Orientation] .....	33, 55
[Screen Orientation]	
.....	88, 90
SD card .....	9, 114
SD Card slot .....	9
Searching .....	34, 55
Searching for notes within	
a book .....	44

- Settings .....88
  - Shuffle .....34, 87
  - Slideshow .....34, 83, 91
  - Sort .....34, 36
  - Specifications..... 19
  - Standby screen.....34, 84, 94
  - Status bar .....30
  - Status indicators during
    - charging ..... 13
  - Stylus..... 9
  - Support ..... 18
  - Supported file format .... 121
  - Symptoms .....97
  - System requirements ..... 123
  - [Saturated] .....52
  - [Screen Orientation] ....33, 54
  - [Search] .....34, 55
  - [Select All]/[Unselect All]
    - .....74
  - [Select Page].....32, 57
  - [Select Standby Screen]
    - .....34, 84
  - [Settings] menu.....29, 88
  - [Shuffle On]/[Shuffle Off]
    - .....34, 87
  - [Slideshow On]/
    - [Slideshow Off] .....34, 83
  - [Slideshow] .....91
  - [Sort] .....34
  - [Standby Screen] .....88, 94
  - [System Management]
    - .....88, 92
- T**
- Text Memo .....76, 80
    - On-screen keyboard.....26
  - Touch screen ..... 10, 23
  - Troubleshooting .....96
  - [Table of Contents] .....32
- U**
- USB connector..... 11, 12
  - Useful Features ..... 4
  - Using an Embedded
    - Dictionaries .....60, 82
- V**
- Viewing pictures .....83
  - Volume button ..... 11, 87
  - [View].....34
- W**
- [Word Logs: Book].....35, 63
  - [Word Logs: Dictionary] ....35
  - [Word Logs: Periodicals]....35
- Z**
- Zooming in .....50, 84