

***EXHIBIT C***

***User Manual***

**SONY®**

3-000-000-11 (1)

# ***Cordless Telephone with Answering System***

---

Operating Instructions

**US**

***High  
Power* 900 MHz**

**CALLER ID**  
with call waiting

***SPP-A9171***

©2000 Sony Corporation

## Owner's Record

The model and the serial numbers are located at the bottom of the unit. Record the serial number in the space provided below. Refer to these numbers whenever you call upon your Sony dealer regarding this product.

Model No. SPP-A9171

Serial No. \_\_\_\_\_

## IMPORTANT SAFETY INSTRUCTIONS

When using your telephone equipment, basic safety precautions should always be followed to reduce the risk of fire, electric shock and injury to persons, including the following:

1. Read and understand all instructions.
2. Follow all warnings and instructions marked on the product.
3. Unplug this product from the wall outlet before cleaning. Do not use liquid cleaners or aerosol cleaners. Use a damp cloth for cleaning.
4. Do not use this product near water, for example, near a bath tub, wash bowl, kitchen sink, or laundry tub, in a wet basement, or near a swimming pool.
5. Do not place this product on an unstable cart, stand, or table. The product may fall, causing serious damage to the product.
6. Slots and openings in the cabinet and the back or bottom are provided for ventilation. To protect it from overheating, these openings must not be blocked or covered. The openings should never be blocked by placing the product on the bed, sofa, rug, or other similar surface. This product should never be placed near or over a radiator or heat register. This product should not be placed in a built-in installation unless proper ventilation is provided.
7. This product should be operated only from the type of power source indicated on the marking label. If you are not sure of the type of power supply to your home, consult your dealer or local power company.
8. Do not allow anything to rest on the power cord. Do not locate this product where the cord will be abused by persons walking on it.
9. Do not overload wall outlets and extension cords as this can result in the risk of fire or electric shock.
10. Never push objects of any kind into this product through cabinet slots as they may touch dangerous voltage points or short out parts that could result in a risk of fire or electric shock. Never spill liquid of any kind on the product.
11. To reduce the risk of electric shock, do not disassemble this product, but take it to a qualified service personnel when some service or repair work is required. Opening or removing covers may expose you to dangerous voltages or other risks. Incorrect reassembly can cause electric shock when the appliance is subsequently used.

12. Unplug this product from the wall outlet and refer servicing to qualified service personnel under the following conditions:

- A. When the power cord or plug is damaged or frayed.
- B. If liquid has been spilled into the product.
- C. If the product has been exposed to rain or water.
- D. If the product does not operate normally by following the operating instructions. Adjust only those controls that are covered by the operating instructions because improper adjustment of other controls may result in damage and will often require extensive work by a qualified technician to restore the product to normal operation.
- E. If the product has been dropped or the cabinet has been damaged.
- F. If the product exhibits a distinct change in performance.

13. Avoid using a telephone (other than a cordless type) during an electrical storm. There may be a remote risk of electric shock from lightning.

14. Do not use the telephone to report a gas leak in the vicinity of the leak.

## SAVE THESE INSTRUCTIONS

### CAUTION:

To reduce the risk of fire or injury to persons by battery, read and follow these instructions.

- 1. Use only the following type and size battery pack: Sony BP-T31.
- 2. Do not dispose of the battery pack in a fire. The cell may explode. Check with local codes for possible special disposal instructions.
- 3. Do not open or mutilate the battery pack. Released electrolyte is corrosive and may cause damage to the eyes or skin. It may be

toxic if swallowed.

- 4. Exercise care in handling battery pack in order not to short the battery with conducting materials such as rings, bracelets, and keys. The battery or conductor may overheat and cause burns.
- 5. Charge the battery pack provided with or identified for use with this product only in accordance with the instructions and limitations specified in the instruction manual provided for this product.
- 6. Observe proper polarity orientation between the battery pack and battery charger.

## INFORMATION FOR GENERAL TELEPHONES

- 1. This equipment complies with Part 68 of the FCC rules. On the bottom of this equipment is a label that contains, among other information, the FCC certification number and ringer equivalence number (REN) for this equipment. If requested, this information must be provided to the telephone company.
- 2. The applicable certification jack (connector) USOC-RJ11C is used for this equipment.
- 3. This equipment is designed to be connected to the telephone network or premises wiring using a compatible modular jack that is Part 68 compliant.  
The FCC compliant telephone cord and modular plug is provided with this equipment.
- 4. The REN is used to determine the quantity of devices that may be connected to the telephone line. Excessive RENs on the telephone line may result in the devices not ringing in response to an incoming call. Typically, the sum of the RENs should not exceed five (5.0). To be certain of the number of devices that may be connected to a line, as determined by the total RENs, contact the local telephone company.
- 5. If this equipment (SPP-A9171) causes harm to the telephone network, the telephone company will notify you in advance that temporary discontinuance of service may be required. But if advance notice isn't practical, the telephone company will notify the customer as soon as possible. Also, you will be advised of your right to file a complaint with the FCC if you believe it is necessary.

6. The telephone company may make changes in its facilities, equipment, operations or procedures that could affect the operation of the equipment. If this happens the telephone company will provide advance notice so you can make necessary modifications to maintain uninterrupted service.
7. If trouble is experienced with this equipment (SPP-A9171), for repair or warranty information, please contact Sony Direct Response Center: Tel 1-800-222-7669. If the equipment is causing harm to the telephone network, the telephone company may request that you disconnect the equipment until the problem is resolved.
8. All repairs will be performed in an authorized Sony service station.
9. This equipment cannot be used to party lines or coin lines.
10. This equipment is hearing aid compatible.

### **If your telephone is equipped with automatic dialers**

When programming emergency numbers and (or) making test calls to emergency numbers:

1. Remain on the line and briefly explain to the dispatcher the reason for the call.
2. Perform such activities in the off-peak hours, such as early morning or late evenings.

### **Caution**

You are cautioned that any changes or modifications not expressly approved in this manual could void your authority to operate this equipment.

### **Note**

This equipment has been tested and found to comply with the limits for a Class B digital device, pursuant to Part 15 of the FCC Rules. These limits are designed to provide reasonable protection against harmful interference in a residential installation. This equipment generates, uses and can radiate radio frequency energy and, if not installed and used in accordance with the instructions, may cause harmful interference to radio communications. However, there is no guarantee that interference will not occur in a particular installation. If this equipment does cause harmful interference to radio or television reception, which can be determined by turning the equipment off and on, the user is encouraged to try to correct the interference by one or more of the following measures:

- Reorient or relocate the receiving antenna.
- Increase the separation between the equipment and receiver.
- Connect the equipment into an outlet on a circuit different from that to which the receiver is connected.
- Consult the dealer or an experienced radio/TV technician for help.

---

# Table of contents

## Getting Started

- 6 Read this first
  - 7 Step 1: Checking the package contents
  - 8 Step 2: Setting up the base unit
  - 11 Step 3: Preparing the battery pack
  - 14 Step 4: Entering the area code
  - 17 Step 5: Changing the language of the display and the voice guide
  - 18 Identifying the parts
- 

## Basics

- 22 Making calls
  - 24 Redialing
  - 25 Receiving calls
- 

## Telephone Features

- 26 One-touch dialing
  - 26 Storing phone numbers
  - 27 Making calls with one-touch dialing
- 28 Phone Directory
  - 28 Storing phone numbers and names
  - 29 Changing a stored name and/or phone number
  - 30 Erasing a memory location
  - 31 Making calls from the Phone Directory
- 32 Paging

## Answering Machine Features

- 33 Preparing the answering machine
  - 33 Setting the day and time
  - 35 Recording the greeting
  - 38 Selecting the ring time
  - 39 Selecting the recording quality

- 40 Selecting the answering mode
- 41 Turning on the answering function
- 43 Playing back messages
- 45 Erasing messages
- 46 Screening incoming calls
- 47 Recording a memo
- 49 Operating from an outside phone
  - 49 Setting the remote ID code
  - 50 Picking up new messages

## Caller ID Features

- 51 Understanding the Caller ID service
  - 51 When you receive a call
- 52 Looking at the Caller ID list
  - 52 Viewing the Caller ID list
  - 53 Erasing data from the Caller ID list
- 55 Using the Caller ID list
  - 55 Calling back a number from the Caller ID list
  - 56 Storing a number of the Caller ID list into the Phone Directory
  - 57 To change the number of digits of the phone number
- 59 Using "Caller ID with call waiting" service

## Additional Information

- 60 Mounting the base unit on a wall
  - 61 Notes on power sources
  - 62 Maintenance
  - 63 Troubleshooting
  - 68 Specifications
  - 69 Index
- 

Back cover LIMITED WARRANTY

## Getting Started

# Read this first

Before you use your phone, you must set it up. Here's a quick way to set up your phone: Steps 1, 2, 3 and 4.

### Step 1 (page 7)

First, unpack the phone and the supplied accessories.

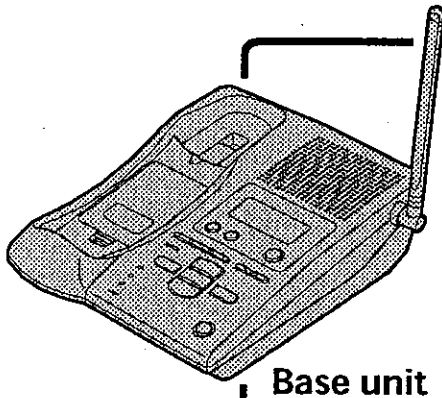

Base unit

### Step 2 (pages 8 to 10)

Next, you need to do three things to set up the base unit, including finding the best location for the base unit.

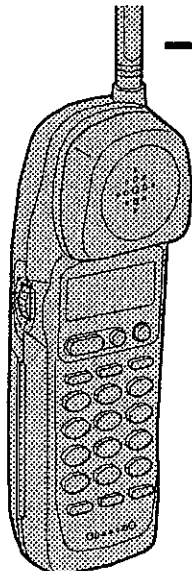

Handset

### Step 3 (pages 11 to 12)

Then, you need to insert the battery pack into the handset and charge it for more than 12 hours.

### Step 4 (pages 14 to 16)

Finally, you need to enter the area code to use the Caller ID service.

***That's it!***

If you want to change the language of the display and the voice guide, follow the procedure in "Step 5 Changing the language of the display and the voice guide" on page 17.

# Step 1

## Checking the package contents

Make sure you have received the following items in the package. If anything is missing, contact your local Sony dealer.

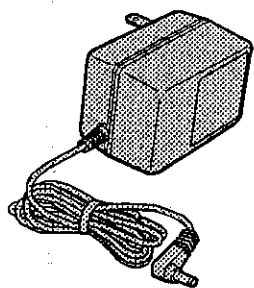

AC power adaptor (AC-T46)

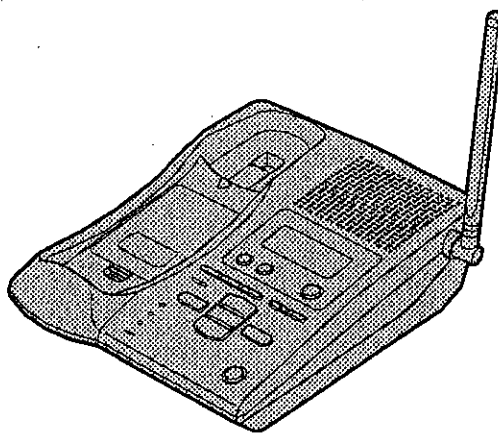

Base unit

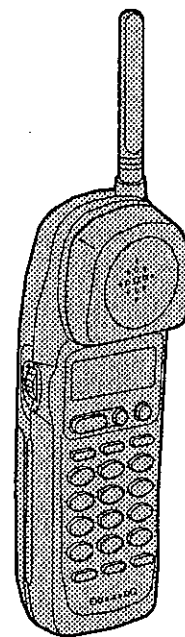

Handset

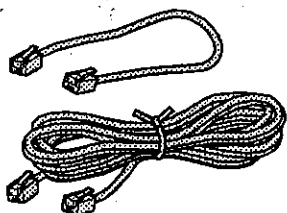

Telephone line cords (2)

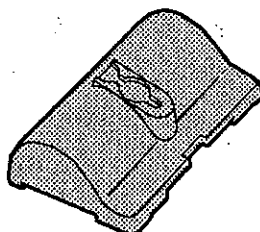

Wall bracket for base unit

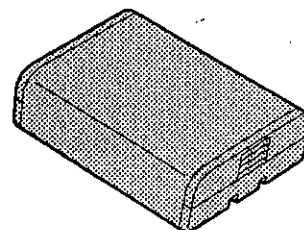

Rechargeable battery pack (BP-T31)



## Step 2

### Setting up the base unit

Do the following steps:

- Choose the best location
- Connect the base unit
- Choose the dialing mode

#### Choose the best location

Where you place the base unit affects the reception quality of the handset.

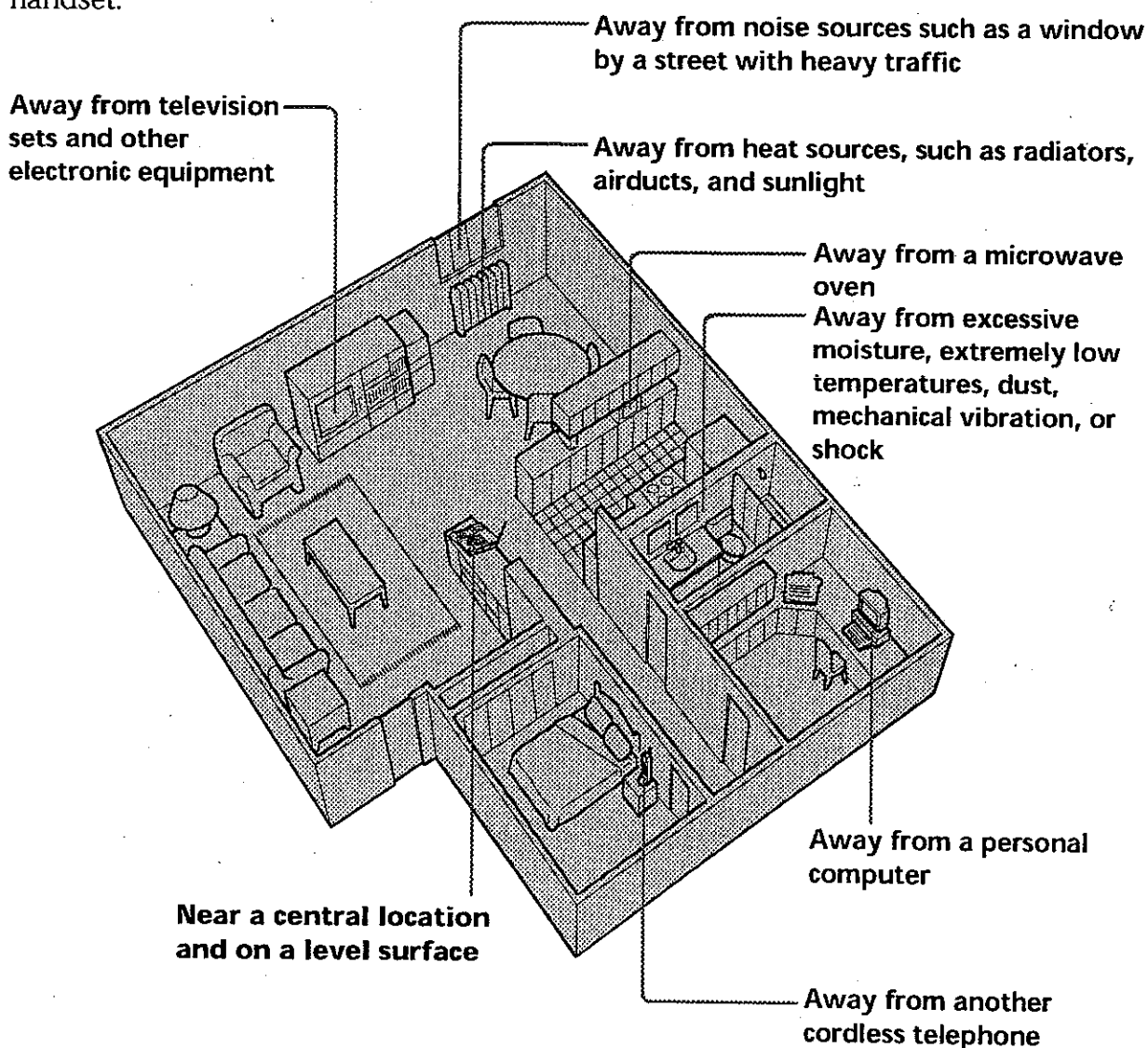

- CAUTION:**
- Should you experience intermittent loss of audio during a conversation, try moving closer to the base or move base unit away from other noise sources.
  - The cordless telephone operates at a frequency that may cause interference to nearby TVs and VCRs; the base unit should not be placed near or on the top of a TV or VCR; and, if interference is experienced, moving the cordless telephone farther away from the TV or VCR will often reduce or eliminate the interference.

## Connect the base unit

If you want to hang the base unit on the wall, see page 60.

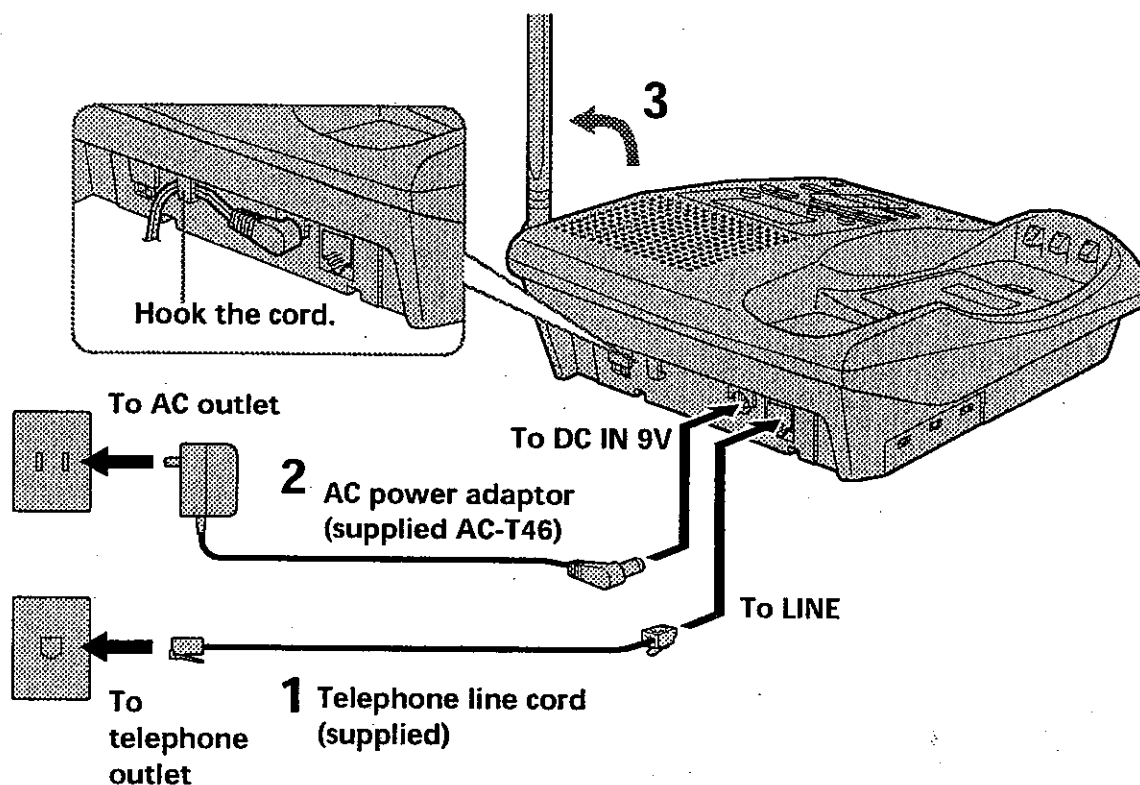

- 1** Connect the telephone line cord to the LINE jack and to a telephone outlet.
- 2** Connect the AC power adaptor to the DC IN 9V jack and to an AC outlet.  
"P" flashes on the display.
- 3** Raise the antenna. Make sure it points toward the ceiling.

continued

## Step 2: Setting up the base unit (continued)

### Notes

- Use only the supplied AC-T46 AC power adaptor. Do not use any other AC power adaptor.
- Connect the AC power adaptor to a continuous power supply.
- Place the base unit close to the AC outlet so that you can unplug the AC power adaptor easily.

### Polarity of the plug



### Tip

If your telephone outlet is not modular, contact your telephone service company for assistance.

### Modular



## Choose the dialing mode

For the telephone to work properly, select an appropriate dialing mode (tone or pulse).

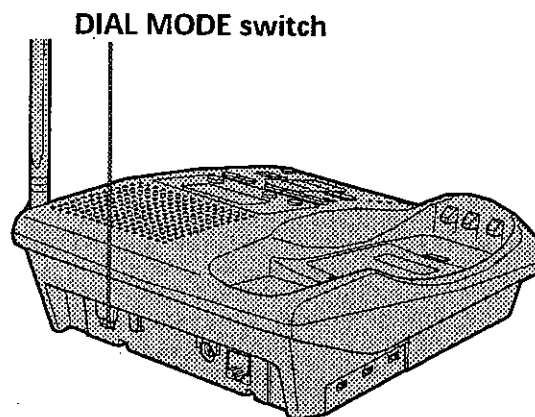

Depending on your dialing system, set the DIAL MODE switch as follows:

If your dialing system is	Set the switch to
Tone	T
Pulse	P

### If you aren't sure of your dialing system

Make a trial call with the DIAL MODE switch set to T. If the call connects, leave the switch as is; otherwise, set to P.

## Step 3

# Preparing the battery pack

Charge the battery pack for more than **12 hours** before you start using your phone.

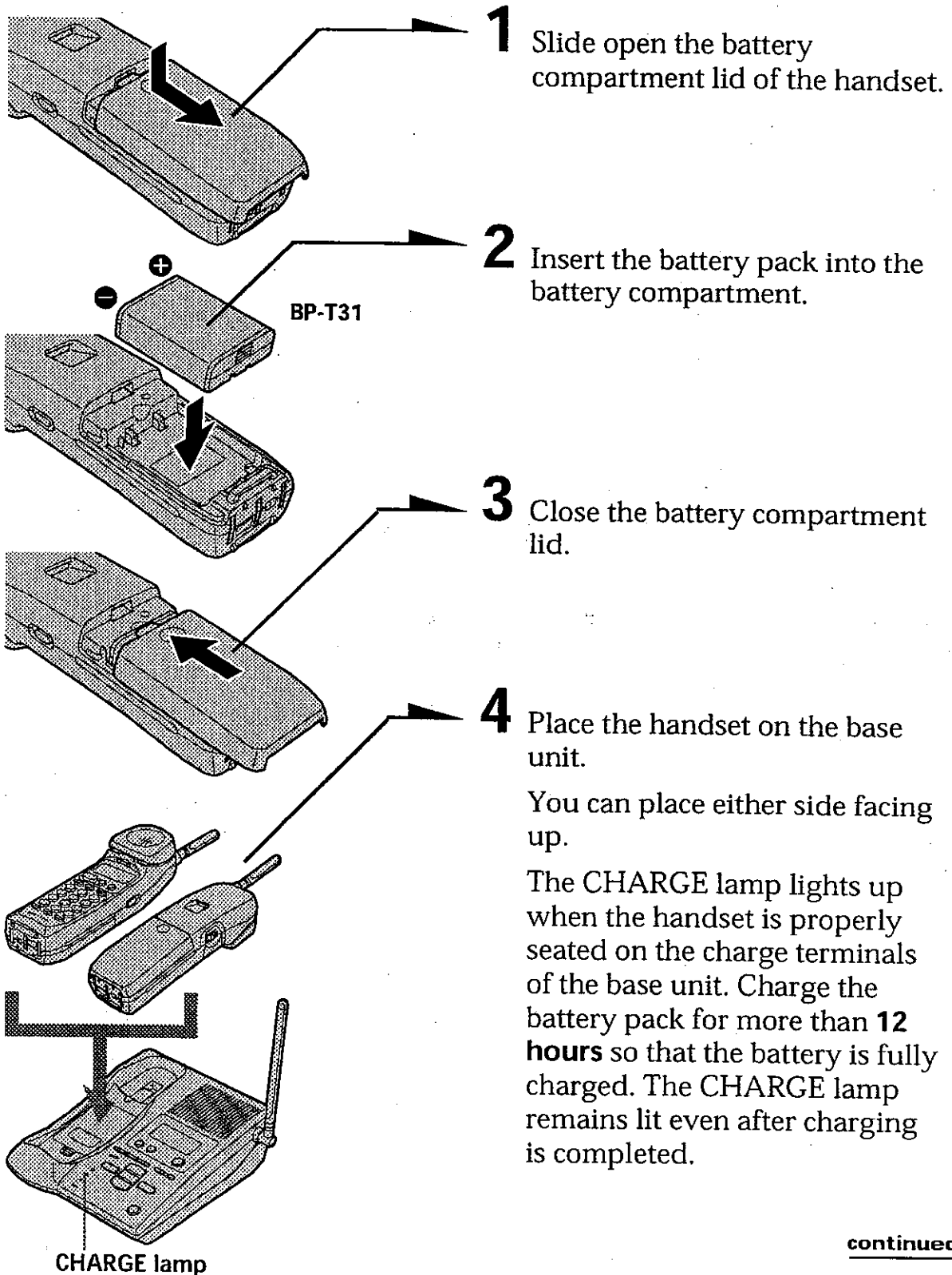

---

## **Step 3: Preparing the battery pack (continued)**

### **Battery duration**

A fully charged battery pack lasts for about:

- Approx. 6 hours when you use the handset continuously
- Approx. 7 days when the handset is in standby mode.

### **Notes**

- The battery pack will gradually discharge over a long period of time, even if not in use.
- If you leave the battery pack in the handset without charging it, the battery pack will be completely discharged.  
It may require several times of charging to recover to its full capacity.
- While charging, the battery pack warms up. This is not a malfunction.

### **To obtain the best performance from the battery**

Do not place the handset on the base unit after each call. The battery works best if the handset is returned to the base unit after two or three calls. However, do not leave the handset off the base unit for a long period of time as this will completely discharge the battery pack.

### **When to purchase a new battery pack**

If the battery lasts only a few minutes even after **12 hours** of charging, the usable life of the battery has expired and needs replacement. Contact your local Sony authorized dealer or service center, and ask for Sony **BP-T31** rechargeable battery pack.

### **Note**

Battery life may vary depending on usage condition and ambient temperature.

## Handset spare battery usage

As only one battery pack is supplied with this unit, it is necessary to purchase an additional battery pack (optional) for use as a handset spare battery pack.

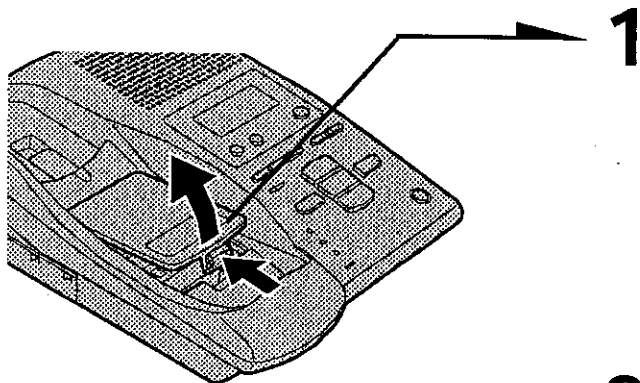

- 1** Open the battery compartment lid of the base unit.

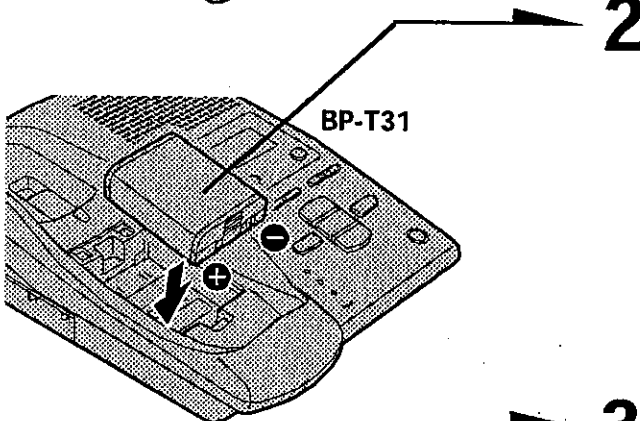

- 2** Insert the battery pack (optional) into the battery compartment.

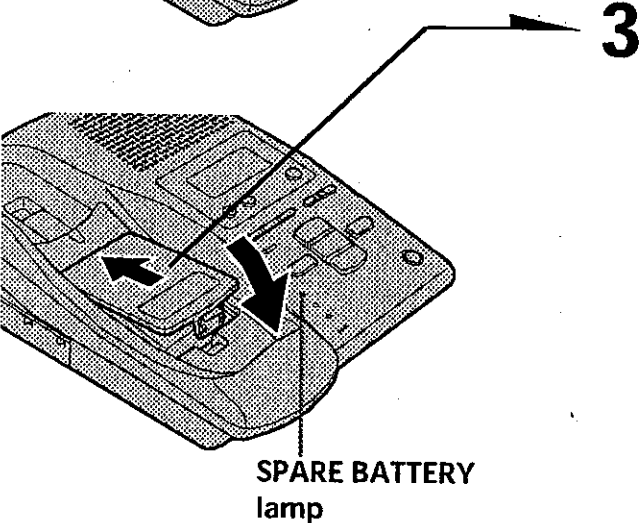

- 3** Close the battery compartment lid.

The SPARE BATTERY lamp lights up. Charge the battery pack for more than 24 hours so that the battery is fully charged. The SPARE BATTERY lamp remains lit even after charging is completed.

## Step 4

### Entering the area code

When you use this phone for the first time, or move to an area that has a different area code, you must enter your home area code. Otherwise, you cannot use some functions of this phone and the Caller ID functions.

This is also necessary because the phone must be able to select an area code to properly dial call from the Caller ID list.

Depending on your region, enter 3-digit area code as follows:

Case 1.

If 7-digit dialing (no area code) is accepted for local calls in your area, see "To enter your home area code" below.

If you live in an area where calls from or to other local areas can also be made by 10-digit dialing (area code + number), you can register up to 5 local area codes with this telephone to take advantage of this system. See "To enter the local area code (For 10 digits phone number users)" on page 15.

Case 2.

If 10-digit dialing (area code + number) is required for all local calls in your area, see "To enter the local area code (For 10 digits phone number users)" on page 15.

### To enter your home area code

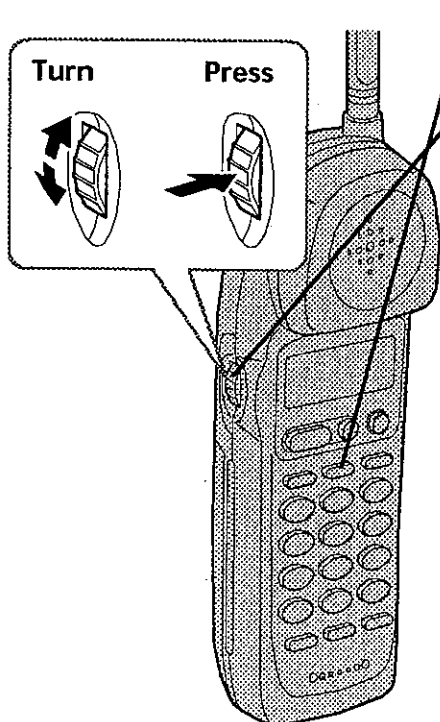

1 Press (PGM).

2 Turn Jog Dial up to make "HOME AREA CODE" flash.



3 Press Jog Dial.  
"ENTER AREA CODE" appears on the display.

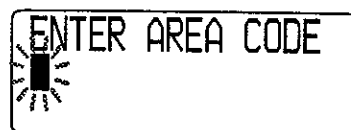

4 Enter the three digits of your home area code using the dialing keys.

5 Press (PGM).

You hear a long confirmation beep.

**Notes**

- If the home area code is already entered, it appears on the display in step 3. To enter a different home area code, see "To change the home area code" below.
- Do not allow more than 20 seconds to elapse between each step of the procedure.
- If the area code has not been entered, calling back from the Caller ID list and storing the Caller ID data into the Phone Directory cannot be performed.

**Tips**

- You may press Jog Dial instead of **PGM** in step 5.
- To check the current home area code, perform steps 1 to 3. The home area code appears on the display for about 20 seconds.

**To change the home area code**

- 1 Perform steps 1 to 3 on page 14.

The current home area code appears on the display.

- 2 Turn Jog Dial down to erase the current home area code.
- 3 Enter a new home area code using the dialing keys.

- 4 Press **PGM**.

You hear a long confirmation beep.

**To erase the home area code**

You can erase the home area code. Perform steps 1 and 2 above, then press **PGM**.

The home area code will be erased, and you hear a long confirmation beep.

**To enter the local area code (For 10 digits phone numbers users)**

If a call matches one of the local area codes you entered, the phone number will be registered with 10 digits in the Caller ID list (area code + number). If a call does not match one of the local area codes you entered, the phone number will be registered with 11 digits in the Caller ID list (1 + area code + number). Some regions of the country allow you to have more than one local area code. (Up to five local area codes can be entered in this phone.)

- 1 Press **PGM**.
- 2 Turn Jog Dial up to make "LOCAL AREA CODE" flash.
- 3 Press Jog Dial.

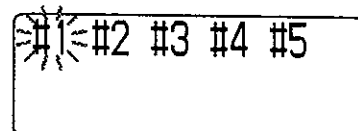

continued



---

## Step 4: Entering the area code (continued)

- 4** Select the number ("#1" to "#5") to enter the local area code by turning Jog Dial.
- 5** Press Jog Dial.  
"ENTER AREA CODE" appears on the display.
- 6** Enter the three digits of the local area code using the dialing keys.
- 7** Press **(PGM)**.  
You hear a long confirmation beep.

### Notes

- If the local area code is already entered, it appears on the display in step 5. To enter a different local area code, see "To change the local area code" below.
- Do not allow more than 20 seconds to elapse between each step of the procedure.

### Tips

- You may press Jog Dial instead of **(PGM)** in step 7.
- To check the current local area code, perform steps 1 to 5. The local area code appears on the display for about 20 seconds.

### To change the local area code

- 1** Perform steps 1 to 5 on page 15.  
The current local area code appears on the display.
- 2** Turn Jog Dial down to erase the current local area code.
- 3** Enter a new local area code using the dialing keys.
- 4** Press **(PGM)**.  
You hear a long confirmation beep.

### To erase the local area code

You can erase the local area code. Perform steps 1 and 2 above, then press **(PGM)**.

The local area code will be erased, and you hear a long confirmation beep.

## Step 5

# Changing the language of the display and the voice guide

You can choose English or Spanish as the display and the voice guide language by following the procedure below.

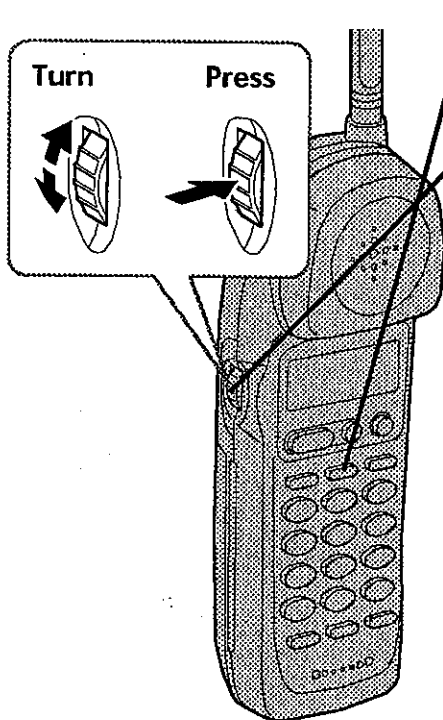

**1** Press **(PGM)**.

**2** Turn Jog Dial up to make "LANGUAGE SELECT" flash, and then press Jog Dial.

Select "ELEGIR IDIOMA" when you want to change the language of the display and the voice guide from Spanish to English.

ENGLISH ~~ESPAÑOL~~

**3** Turn Jog Dial to choose the language, and then press Jog Dial.

ESPAÑOL ~~NO~~ ~~SÍ~~

**4** Select "SÍ" by turning Jog Dial to change the language, and then press Jog Dial.

Select "YES", and then press Jog Dial when you choose "ENGLISH" in step 3.

You will hear a long confirmation beep.

### Note

Do not allow more than 20 seconds to elapse between each step of the procedure.

# Identifying the parts

Refer to the pages indicated in parentheses for details.

## Base Unit

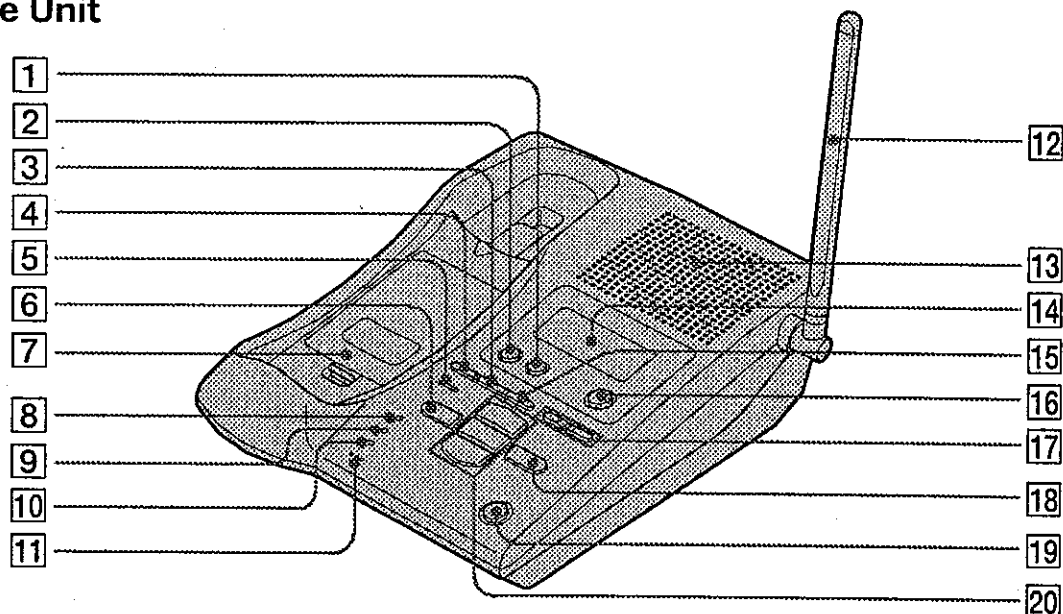

- |  |  |
|--|--|
| <p><b>1</b> <b>ERASE button</b> (p. 37, 45)<br/>Erases the recorded greeting or messages.</p> <p><b>2</b> <b>MEMO button</b> (p. 47)<br/>Records a memo message.</p> <p><b>3</b> <b>REETING REC button</b> (p. 35)<br/>Press to record a greeting.</p> <p><b>4</b> <b>REETING PLAY button</b> (p. 37)<br/>Plays back the greeting message.</p> <p><b>5</b> <b>NEW CALL lamp</b> (p. 52)<br/>Flashes when there is a "NEW" data in the Caller ID list.</p> <p><b>6</b> <b>◀◀ REPEAT/REVIEW button</b> (p. 44)<br/>Press to repeat the current message or go back to the previous message. Keep the button pressed for a playback review of the current message.</p> <p><b>7</b> <b>Battery compartment</b> (p. 13)</p> <p><b>8</b> <b>SPARE BATTERY lamp</b> (p. 13)<br/>Lights while the spare battery is being charged.</p> | <p><b>9</b> <b>CHARGE lamp</b> (p. 11)<br/>Lights while the battery is being charged.</p> <p><b>10</b> <b>IN USE lamp</b> (p. 22)<br/>Lights when the handset is in use.</p> <p><b>11</b> <b>MIC (microphone)</b> (p. 35, 47)</p> <p><b>12</b> <b>Antenna</b> (p. 9, 60)</p> <p><b>13</b> <b>Speaker</b></p> <p><b>14</b> <b>Display window</b> (p. 19, 43)</p> <p><b>15</b> <b>TIME button</b> (p. 34)<br/>Press to check the current time.</p> <p><b>16</b> <b>ANSWER ON/OFF button</b> (p. 41)<br/>Turns the answering function on or off. Lights when the answering function is on, and flashes when a new message is recorded.</p> <p><b>17</b> <b>VOLUME +/- buttons</b> (p. 44)<br/>Adjusts the speaker volume.</p> <p><b>18</b> <b>▶▶ SKIP/QUICK button</b> (p. 44)<br/>Press to skip to the next message. Keep the button pressed for quick playback of messages.</p> |
|--|--|

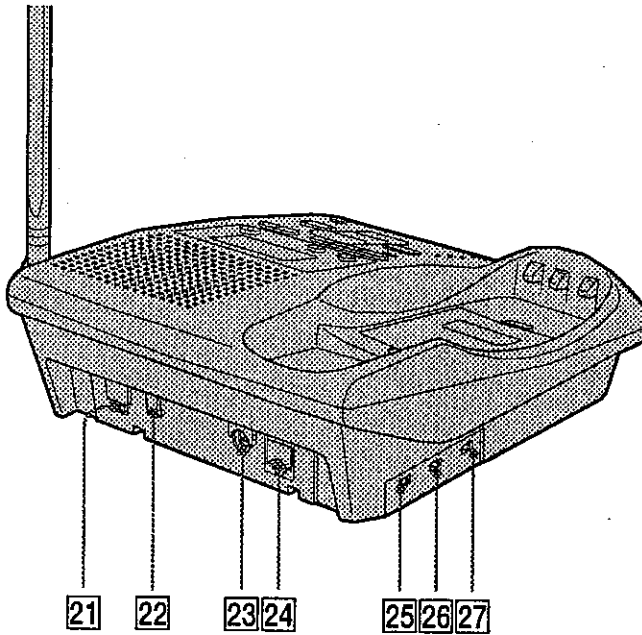

## Display

The display on the base unit shows the answering machine operation.

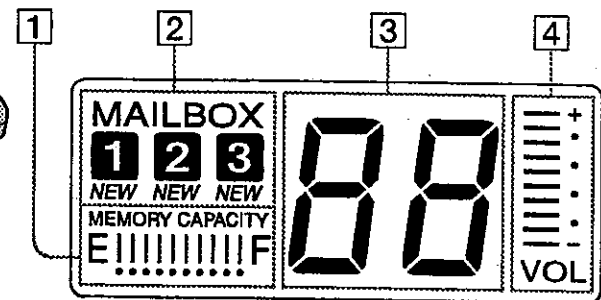

- 19 HANDSET LOCATOR button** (p. 32)  
Allows you to page the handset.
- 20 PLAY/STOP (MAILBOX 1, 2, 3) buttons** (p. 43)  
Plays back the messages in each mail box.
- 21 DIAL MODE switch** (p. 10)  
Selects pulse or tone dialing.
- 22 Hook for AC power adaptor cord** (p. 9)
- 23 DC IN 9V jack** (p. 9)
- 24 LINE (telephone line) jack** (p. 9)
- 25 AUDIBLE INDICATOR switch** (p. 40)  
Selects the answering mode.
- 26 REC. QUALITY switch** (p. 39)  
Selects the recording quality.
- 27 RINGER SELECT switch** (p. 38)  
Selects the ring time.

- 1 Memory capacity indicator** (p. 40)

Indicates the available memory capacity, from E (Empty) to F (Full), for recording. The bars increase as the available memory capacity decreases.

- 2 MAILBOX indicator** (p. 43)

Displayed when there are messages recorded and when the messages are being played back.

"NEW" flashes when there are new messages recorded.

- 3 Message counter** (p. 43)

Indicates the number of new messages recorded. "A" appears in the announcement only mode. "F" appears when there is no space to record messages. "P" appears when the power is turned on.

- 4 VOL (volume) indicator**

Indicates the speaker volume. The bars increase as the volume is turned up.

continued

## Identifying the parts (continued)

### Handset

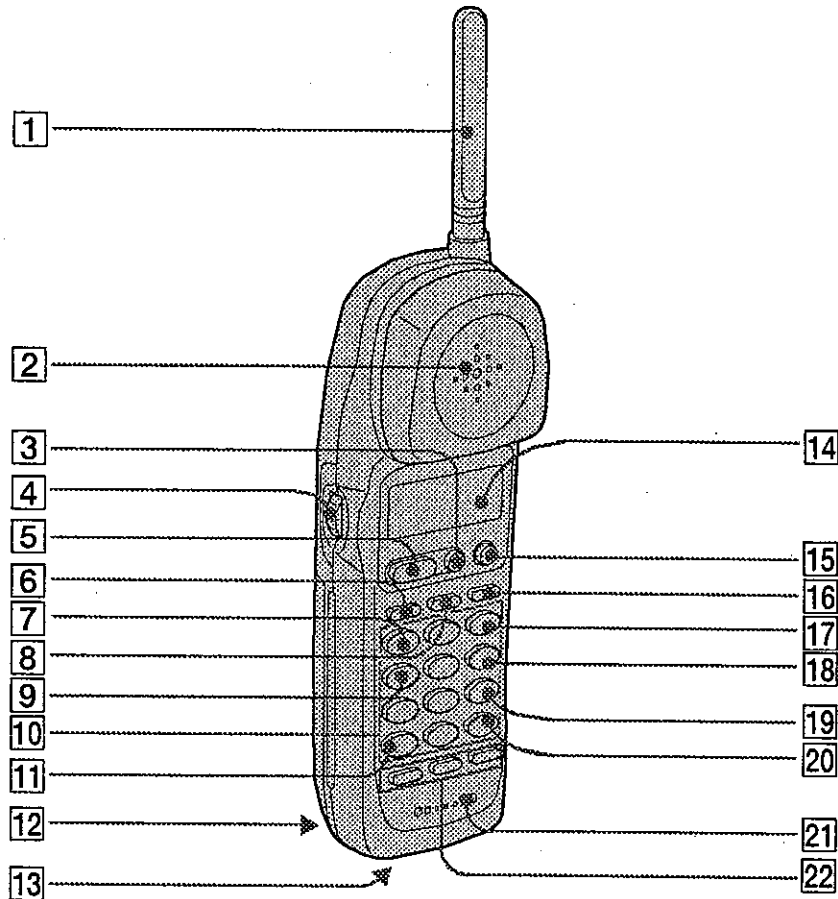

- |  |  |
|--|--|
| <b>1</b> Antenna   | <b>8</b> PGM (Program) button<br>(p. 14, 26, 28)<br>Used to store numbers for one-touch dialing or in Phone Directory. |
| <b>2</b> Speaker [EZfit] (p. 23)   | <b>9</b> REVIEW button (p. 44)<br>Keep the button pressed for a playback review of the current message.                |
| <b>3</b> OFF button (p. 22)<br>Allows you to disconnect the call.  | <b>10</b> Dialing keys (p. 22)   |
| <b>4</b> Jog dial (p. 14, 26, 52)  | <b>11</b> * TONE button (p. 22)<br>Allows you to switch temporarily to tone dialing.                                   |
| <b>5</b> TALK button (p. 22)<br>Lets you make or receive a call.   | <b>12</b> Battery compartment (p. 11)  |
| <b>6</b> REMOTE button (p. 33)<br>Used to display the answering machine function menu.                       | <b>13</b> RING switch (p. 25)<br>Switches the ringer to on/off.  |
| <b>7</b> ◀◀ REPEAT button (p. 44)<br>Press to repeat the current message or go back to the previous message. | <b>14</b> Display window (p. 51)   |

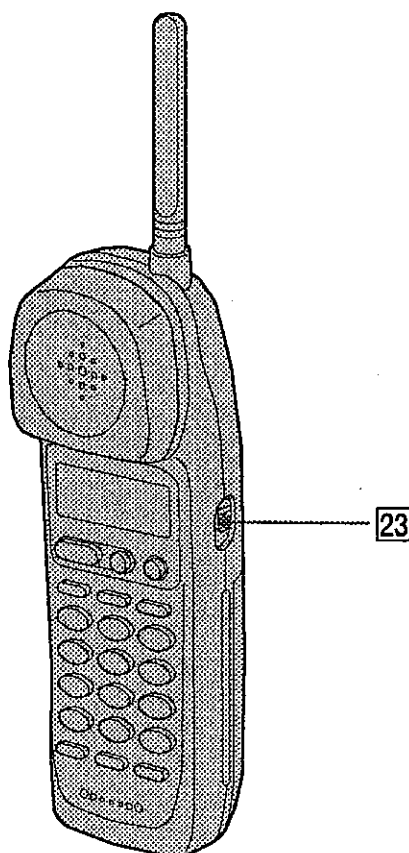

- 15 CALL WAITING/FLASH button** (p. 22, 25, 59)  
Switches to a second call if you have "call waiting" service, or lets you make a new call.
- 16 REDIAL/PAUSE button** (p. 24, 27)  
Redials the last number called/ inserts a pause in the dialing sequence.
- 17 ►► SKIP button** (p. 44)  
Press to skip to the next message.
- 18 QUICK button** (p. 44)  
Keep the button pressed for quick playback of messages.
- 19 ERASE button** (p. 37, 45)  
Erases the recorded greeting or messages.
- 20 # button** (p. 57)  
Used to change the number of digits of the phone number in the Caller ID list.
- 21 Microphone**
- 22 ONE-TOUCH DIAL (A, B, C) buttons** (p. 27)
- 23 VOL (volume) switch** (p. 25)  
Adjust the handset volume.

# Making calls

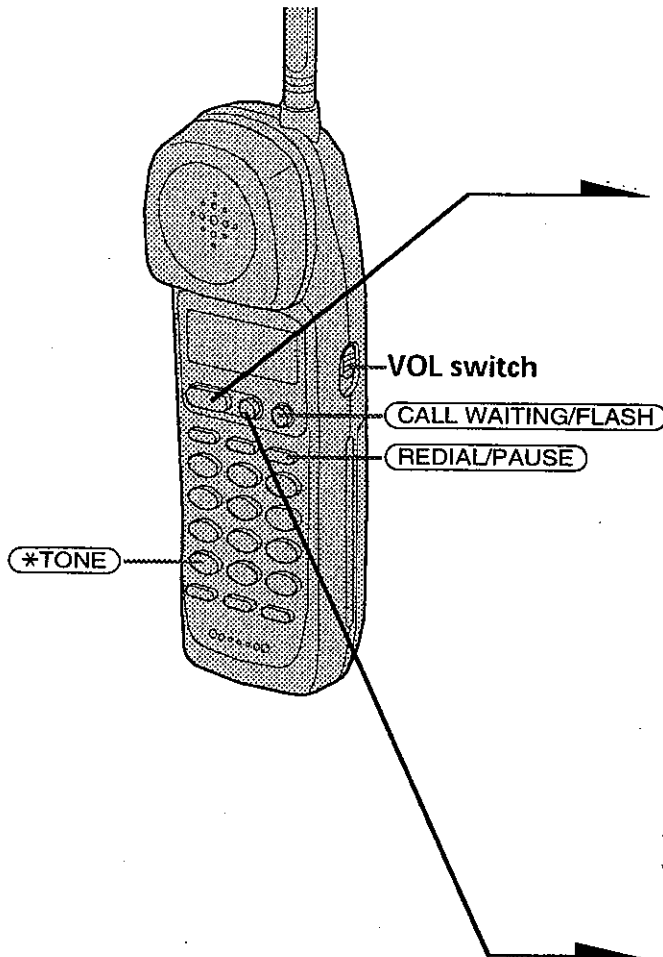

- 1** Pick up the handset from the base unit.
- 2** Press **TALK** and wait until "TALK" appears on the display. The display also shows the operation duration in hours, minutes and seconds.  
The dialing keys light up.  
The IN USE lamp on the base unit lights up.  
You then hear a dial tone. If you hear five short error beeps and "OUT OF RANGE" appears on the display, move closer to the base unit.
- 3** Dial the phone number.
- 4** When you're done talking, press **OFF** or replace the handset on the base unit.  
The display turns off.

## Additional tasks

To	Do this
Adjust the handset volume	Set the VOL switch to H (high), M (middle) or L (low).
Switch to tone dialing temporarily	Press <b>*TONE</b> after you're connected. The line will remain in tone dialing until disconnected.
Switch to another call ("call waiting" service*)	Press <b>CALL WAITING/FLASH</b> . Press <b>CALL WAITING/FLASH</b> again to return to the first caller.

\* You need to subscribe to this service from your telephone company.

**Notes**

- When you increase the sound volume, in some cases the background noise may be increased as well. You should adjust the volume accordingly.
- If the handset beeps every second during conversation and "OUT OF RANGE" appears on the display, move closer to the base unit; otherwise, the call will be disconnected after one minute.
- While the base unit is in use, you cannot make a call with the handset. If you press **TALK**, "BASEPHONE IN USE" appears on the display and you will hear a busy tone.

**EZfit**

The "EZfit" adjusts to fit any shape ear, thereby ensure clear voice reception.

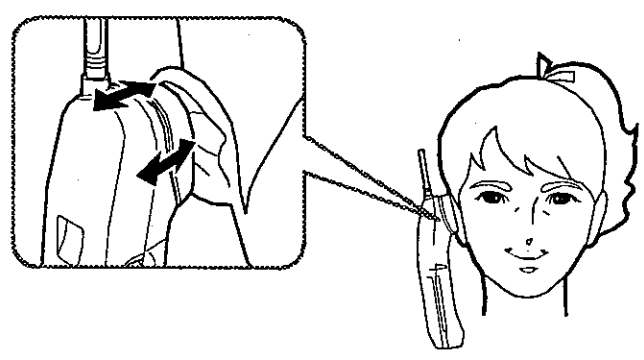

**If the battery becomes weak during a call**

The handset will beep twice per second,  and "BATTERY LOW" appear on the display. Finish your call and charge the battery pack.

**For optimum performance, charge the battery for a full 12 hours.**

Note that during the initial charge time (approx. 10 minutes),  and "BATTERY LOW" appear on the display and the phone cannot be used.

After  and "BATTERY LOW" go off, you **may** be able to use the phone, but the battery duration will be **very short**; thus it is recommended that you **fully charge** the battery before next use.



---

## Making calls (continued)

### Redialing

- 1 Press **TALK** and wait until "TALK" appears on the display.
- 2 Press **REDIAL/PAUSE** to redial the number last dialed.

#### Note

If the number exceeds 32 digits, five short error beeps will alert you that the number cannot be dialed.

### To check the phone number before redialing

While the handset is not in use, press **REDIAL/PAUSE**.

The number last dialed is displayed for five seconds.

To dial the number, press **TALK** while the number is displayed.

#### Note

The number will not be displayed if the last dialed number exceeds 32 digits or if it is erased.

### To erase the last phone number dialed

While the handset is not in use, press **REDIAL/PAUSE** twice.

The number will be erased from the memory, and you will hear a long confirmation beep.

# Receiving calls

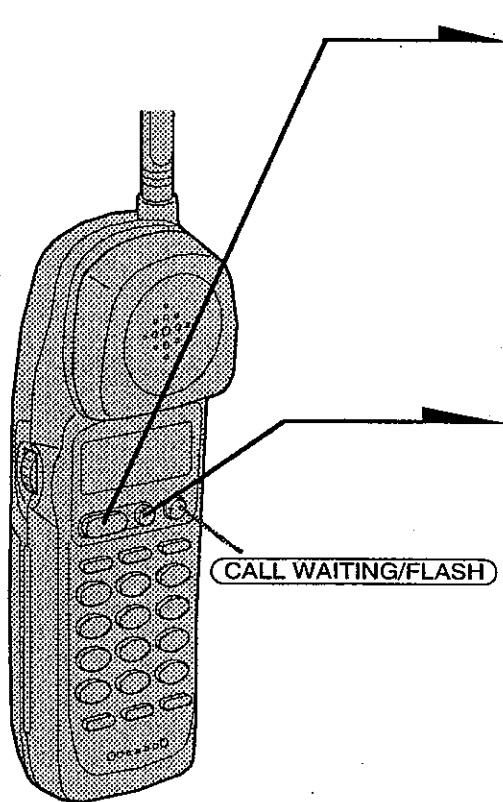

**1** When you hear the phone ring, pick up the handset from the base unit, and press **TALK**. "TALK" appears on the display and the display also shows the operation duration in hours, minutes and seconds.

**2** When you're done talking, press **OFF** or replace the handset on the base unit. The display turns off.

## Tip

If you have subscribed to the Caller ID service;

- the caller's number and/or name appears on the display when you receive a call (see page 51)
- the ringer sound changes to a higher tone if the call matches the number stored on ONE-TOUCH DIAL buttons or in the Phone Directory (memory match function; see page 51).

## To switch to another call ("call waiting" service\*)

Press **CALL WAITING/FLASH**.

Press the button again to get back to the first caller.

\* You need to subscribe to the service from your telephone company.

## To turn the ringer off

Set the RING switch on the bottom to OFF.

The handset won't ring. You can still make calls, and also receive calls if another telephone connected to the same line rings to inform you on incoming calls. You can also page the handset from the base unit.

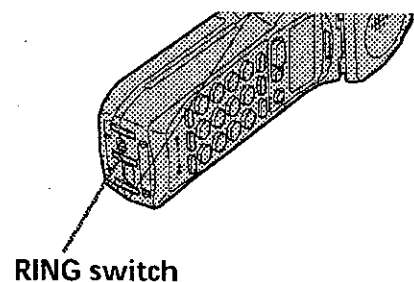

## Telephone Features

# One-touch dialing

You can dial with one touch of a key by storing a phone number on a one-touch dialing button.

### Storing phone numbers

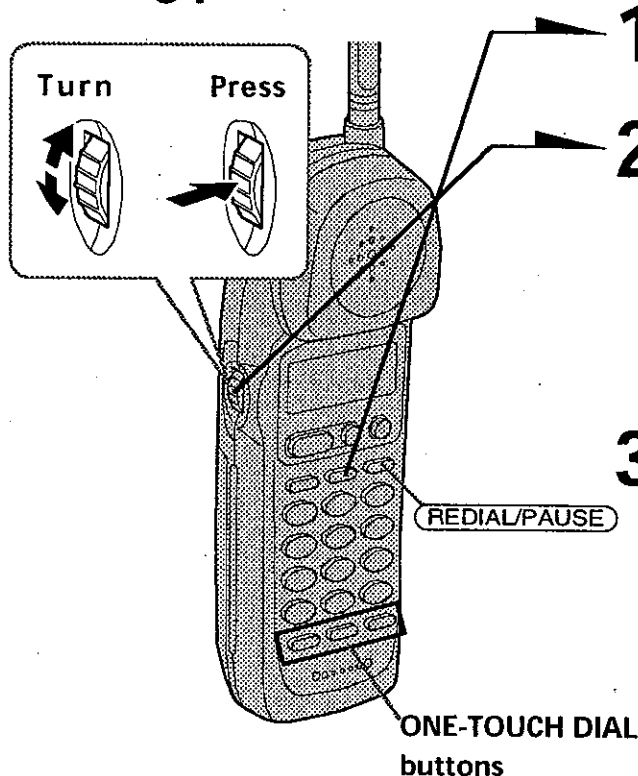

**1** Press (PGM).

**2** Turn Jog Dial up to make "ONE-TOUCH A" to "ONE-TOUCH C" flash.



**3** Press Jog Dial.  
You hear a confirmation beep.



If a number is stored, it appears on the display. To store a new number, turn Jog Dial down to erase it.

**4** Enter the phone number you want to store.

You can enter up to 20 digits, including a tone and a pause, each of which is counted as one digit.

When the phone number of 17 digits or more has been entered, the phone number appears in two lines.

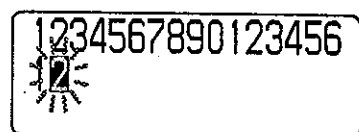

**5** Press (PGM).

You hear a long confirmation beep, and the number is stored.

The display turns off.

**Note**

Do not allow more than 20 seconds to elapse between each step of the procedure.

**Tips**

- When the phone number of 17 digits or more has been entered, “-” is displayed next to 15th digit in step 5.
- If you have entered a wrong number in step 4 and have not pressed **(PGM)** (step 5) yet, just turn Jog Dial down to erase it. Then enter the correct number.
- You may press Jog Dial instead of **(PGM)** in step 5.

**To store a number to be dialed via Private Branch Exchange (PBX)**

Before entering a phone number in step 4 on page 26, do as follows:

- 1** Enter the outside line access digit (e.g., 9).
- 2** Press **(REDIAL/PAUSE)**.

**To change a stored number**

- 1** Perform steps 1 to 3 on page 26.  
The current number appears on the display.
- 2** Turn Jog Dial down to erase the current number.
- 3** Enter a new number.
- 4** Press **(PGM)**.

**Note**

You can replace the stored number with a new number, but you cannot just erase it.

**Making calls with one-touch dialing**

- 1** Press **(TALK)** and wait until “TALK” appears on the display.
- 2** Press one of the ONE-TOUCH DIAL buttons (**(A)** to **(C)**).  
The phone number stored on the one-touch dialing button will appear on the display and will be dialed.

**To check the phone number before one-touch dialing**

While the handset is not in use, press one of the ONE-TOUCH DIAL buttons (**(A)** to **(C)**).

The number stored on the button appears on the display for five seconds. To dial the number, press **(TALK)** while the number is displayed.

**Tip**

When the phone number of 17 digits or more has been entered, “-” is displayed next to 15th digit and then the all digits are displayed in two lines after about two seconds.

# Phone Directory

You can dial a number by scrolling through the Phone Directory.  
You can store up to 100 numbers.

## Storing phone numbers and names

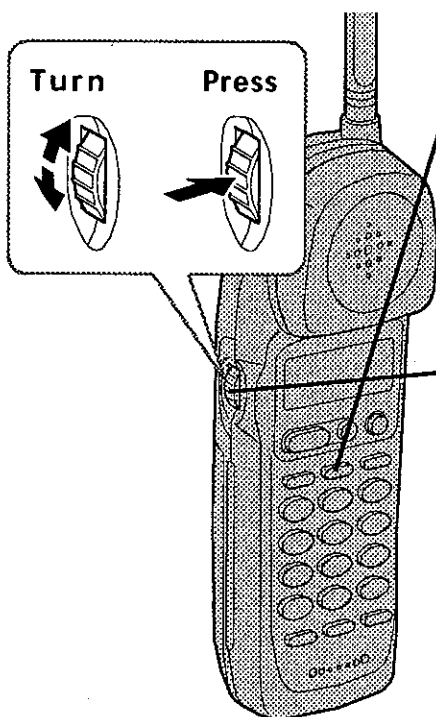

**Example:** to store "SONY" "123-4567".

**1** Press (PGM).



**2** Press Jog Dial.  
"ENTER NAME" appears.

**3** Enter the name using the dialing keys. You can enter up to 15 characters.

Press a dialing key until the desired character appears. (See the character table for details.)

Enter successive characters in the same way.

To enter two characters assigned to the same key, or to enter a "space", turn Jog Dial up to move the cursor to the right.

**Example:** to enter "SONY", press (7) four times (S), press (6) three times (O), turn Jog Dial up to move the cursor, press (6) twice (N), and press (9) three times (Y).

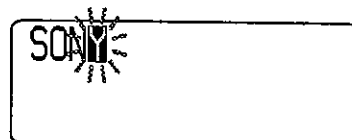

### Character table

Key	Character
①	1
②	A → B → C → 2
③	D → E → F → 3
④	G → H → I → 4
⑤	J → K → L → 5
⑥	M → N → O → 6
⑦	P → Q → R → S → 7
⑧	T → U → V → 8
⑨	W → X → Y → Z → 9
⑩	0
*	*
#	& → ' → , → - → . → #

**4** Press **(PGM)**.

"ENTER NUMBER" appears.

**5** Enter the phone number.

You can enter up to 20 digits, including a tone and a pause, each of which is counted as one digit.

When the phone number of 17 digits or more has been entered, the phone number appears in two lines.

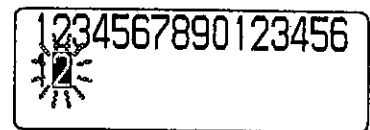
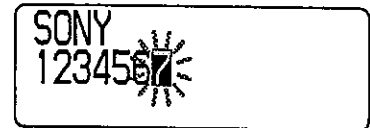

**6** Press **(PGM)**.

You hear a long confirmation beep, and the name and the number are stored. The display turns off.

**Notes**

- If you try to save a 101st phone number, you will hear five short error beeps and "MEMORY FULL" will be displayed. You cannot store the phone number. To store another phone number, erase one of the stored phone numbers (see page 30).
- Do not allow more than 20 seconds to elapse between each step of the procedure.

**Tips**

- When the phone number of 17 digits or more has been entered, "-" is displayed next to 15th digit in step 6.
- If you have entered a wrong name or number in step 3 or 5, turn Jog Dial down to erase it. Then enter the correct name or number.
- You may press Jog Dial instead of **(PGM)** in steps 4 and 6.
- To store a number to be dialed via PBX, follow the steps on page 27 when entering a phone number.

**Changing a stored name and/or phone number**

**1** Display the name and phone number you want to change by doing steps 1 and 2 on page 31.

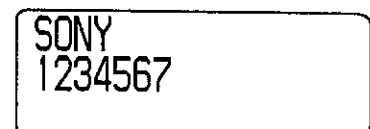

**2** Press Jog Dial.

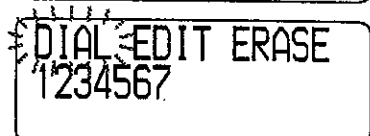

**continued**

---

## Phone Directory (continued)

- 3** Turn Jog Dial up to make "EDIT" flash and press Jog Dial.

The cursor flashes at the last character of the name.

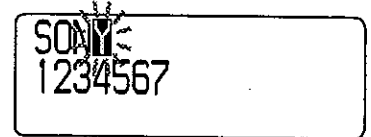

- 4** Turn Jog Dial down to erase the characters and enter the new name.

If you want to change only the number, skip this step.

- 5** Press Jog Dial.

The cursor flashes at the last digit of the phone number.



- 6** Turn Jog Dial down to erase the number and enter the new number.

If you don't want to change the number, skip this step.

- 7** Press Jog Dial.

You hear a long confirmation beep and the name and/or the number is changed.

### Tip

When the phone number of 17 digits or more has been entered, "-" is displayed next to 15th digit and then the all digits are displayed in two lines after about two seconds.

## Erasing a memory location

- 1** Display the name and phone number you want to erase by doing steps 1 and 2 on page 31.

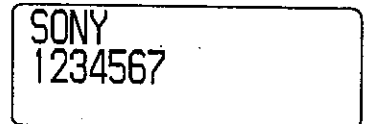

- 2** Press Jog Dial.

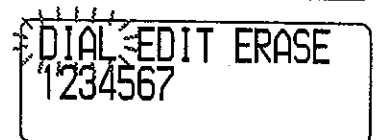

- 3** Turn Jog Dial up to make "ERASE" flash and press Jog Dial.

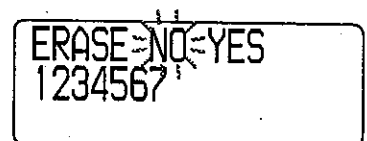

- 4** Turn Jog Dial up to make "YES" flash, then press Jog Dial.

You hear a long confirmation beep and the memory location is erased.