



**SONY.**

3-862-954-11 (1)

# ***Cordless Telephone***

---

Operating Instructions

**EN**

Manual de instrucciones

**ES**

*Spread  
Spectrum* **900** MHz

**CALLER ID**  
with call waiting

**SPP-SS965**

©1998 by Sony Corporation

### Owner's Record

The model and the serial numbers are located at the bottom of the unit. Record the serial number in the space provided below. Refer to these numbers whenever you call upon your Sony dealer regarding this product.

Model No. SPP-SS965

Serial No. \_\_\_\_\_

## IMPORTANT SAFETY INSTRUCTIONS

When using your telephone equipment, basic safety precautions should always be followed to reduce the risk of fire, electric shock and injury to persons, including the following:

1. Read and understand all instructions.
2. Follow all warnings and instructions marked on the product.
3. Unplug this product from the wall outlet before cleaning. Do not use liquid cleaners or aerosol cleaners. Use a damp cloth for cleaning.
4. Do not use this product near water, for example, near a bath tub, wash bowl, kitchen sink, or laundry tub, in a wet basement, or near a swimming pool.
5. Do not place this product on an unstable cart, stand, or table. The product may fall, causing serious damage to the product.
6. Slots and openings in the cabinet and the back or bottom are provided for ventilation. To protect it from overheating, these openings must not be blocked or covered. The openings should never be blocked by placing the product on the bed, sofa, rug, or other similar surface. This product should never be placed near or over a radiator or heat register. This product should not be placed in a built-in installation unless proper ventilation is provided.
7. This product should be operated only from the type of power source indicated on the marking label. If you are not sure of the type of power supply to your home, consult your dealer or local power company.
8. Do not allow anything to rest on the power cord. Do not locate this product where the cord will be abused by persons walking on it.
9. Do not overload wall outlets and extension cords as this can result in the risk of fire or electric shock.
10. Never push objects of any kind into this product through cabinet slots as they may touch dangerous voltage points or short out parts that could result in a risk of fire or electric shock. Never spill liquid of any kind on the product.
11. To reduce the risk of electric shock, do not disassemble this product, but take it to a qualified service personnel when some service or repair work is required. Opening or removing covers may expose you to dangerous voltages or other risks. Incorrect reassembly can cause electric shock when the appliance is subsequently used.

12. Unplug this product from the wall outlet and refer servicing to qualified service personnel under the following conditions:

- A. When the power cord or plug is damaged or frayed.
- B. If liquid has been spilled into the product.
- C. If the product has been exposed to rain or water.
- D. If the product does not operate normally by following the operating instructions. Adjust only those controls that are covered by the operating instructions because improper adjustment of other controls may result in damage and will often require extensive work by a qualified technician to restore the product to normal operation.
- E. If the product has been dropped or the cabinet has been damaged.
- F. If the product exhibits a distinct change in performance.

13. Avoid using a telephone (other than a cordless type) during an electrical storm. There may be a remote risk of electric shock from lightning.

14. Do not use the telephone to report a gas leak in the vicinity of the leak.

## SAVE THESE INSTRUCTIONS

### CAUTION:

To reduce the risk of fire or injury to persons by battery, read and follow these instructions.

- 1. Use only the following type and size battery pack: Sony BP-T24.
- 2. Do not dispose of the battery pack in a fire. The cell may explode. Check with local codes for possible special disposal instructions.
- 3. Do not open or mutilate the battery pack. Released electrolyte is corrosive and may cause damage to the eyes or skin. It may be toxic if swallowed.

- 4. Exercise care in handling battery pack in order not to short the battery with conducting materials such as rings, bracelets, and keys. The battery or conductor may overheat and cause burns.
- 5. Charge the battery pack provided with or identified for use with this product only in accordance with the instructions and limitations specified in the instruction manual provided for this product.
- 6. Observe proper polarity orientation between the battery pack and battery charger.

### INFORMATION FOR GENERAL TELEPHONES

1. This equipment complies with Part 68 of the FCC rules. On the bottom of this equipment is a label that contains, among other information, the FCC registration number and ringer equivalence number (REN) for this equipment. If requested, this information must be provided to the telephone company.

2. The applicable registration jack (connector) USOC-RJ11C is used for this equipment.

3. This equipment is designed to be connected to the telephone network or premises wiring using a compatible modular jack which is Part 68 compliant.

The FCC compliant telephone cord and modular plug is provided with this equipment.

4. The REN is used to determine the quantity of devices which may be connected to the telephone line. Excessive RENs on the telephone line may result in the devices not ringing in response to an incoming call. In most, but not all areas, the sum of the RENs should not exceed five (5.0). To be certain of the number of devices that may be connected to a line, as determined by the total RENs, contact the local telephone company.

5. If your equipment (SPP-SS965) causes harm to the telephone network, the telephone company will notify you in advance that temporary discontinuance of service may be required. But if advance notice isn't practical, the telephone company will notify the customer as soon as possible. Also, you will be advised of your right to file a complaint with the FCC if you believe it is necessary.

EN

6. The telephone company may make changes in its facilities, equipment, operations or procedures that could affect the operation of the equipment. If this happens the telephone company will provide advance notice in order for you to make necessary modifications to maintain uninterrupted service.
7. If trouble is experienced with this equipment (SPP-SS965), for repair or warranty information, please contact Sony Direct Response Center: Tel 1-800-222-7669. If the equipment is causing harm to the telephone network, the telephone company may request that you disconnect the equipment until the problem is resolved.
8. All repairs will be performed in an authorized Sony service station.
9. This equipment cannot be used to party lines or coin lines.
10. This equipment is hearing aid compatible.

### **If your telephone is equipped with automatic dialers**

When programming emergency numbers and (or) making test calls to emergency numbers:

1. Remain on the line and briefly explain to the dispatcher the reason for the call.
2. Perform such activities in the off-peak hours, such as early morning or late evenings.

### **Caution**

You are cautioned that any changes or modifications not expressly approved in this manual could void your authority to operate this equipment.

### **Note**

This equipment has been tested and found to comply with the limits for a Class B digital device, pursuant to Part 15 of the FCC Rules. These limits are designed to provide reasonable protection against harmful interference in a residential installation. This equipment generates, uses and can radiate radio frequency energy and, if not installed and used in accordance with the instructions, may cause harmful interference to radio communications. However, there is no guarantee that interference will not occur in a particular installation. If this equipment does cause harmful interference to radio or television reception, which can be determined by turning the equipment off and on, the user is encouraged to try to correct the interference by one or more of the following measures:

- Reorient or relocate the receiving antenna.
- Increase the separation between the equipment and receiver.
- Connect the equipment into an outlet on a circuit different from that to which the receiver is connected.
- Consult the dealer or an experienced radio/TV technician for help.

# Table of contents

## Getting Started

- 6 Read this first
- 7 Step 1: Checking the package contents
- 8 Step 2: Setting up the base phone
- 11 Step 3: Preparing the battery pack
- 13 Step 4: Entering your area code

## Basics

- 14 Making calls
- 16 Redialing
- 17 Receiving calls

## Telephone Features

- 19 One-touch dialing
  - 19 Storing phone numbers
  - 20 Making calls with one-touch dialing
- 21 Speed dialing
  - 21 Storing phone numbers
  - 22 Making calls with speed dialing
- 23 Phone Directory
  - 23 Storing phone numbers and names
  - 24 Changing a stored name and/or phone number
  - 25 Erasing a memory location
  - 26 Making calls from the Phone Directory
- 27 Switching the phones during a call
  - 27 To switch from the base phone to the handset
  - 27 To switch from the handset to the base phone

- 28 Talking between the phones (Intercom)
  - 28 To talk from the handset to the base phone
  - 28 To talk from the base phone to the handset
- 29 Voice paging
  - 29 To page with voice
- 30 Transferring a call
  - 30 To transfer from the base phone to the handset
  - 31 To transfer from the handset to the base phone

## Caller ID Features

- 32 Understanding the Caller ID service
  - 32 When you receive a call
- 33 Looking at the Caller ID list
  - 33 Viewing the Caller ID list
  - 34 Erasing data from the Caller ID list
- 36 Using the Caller ID list
  - 36 Calling back a number from the Caller ID list
  - 37 Storing a number of the Caller ID list into the Phone Directory
- 38 Using "Caller ID with call waiting" service

## Additional Information

- 39 Mounting the base phone on a wall
- 40 Notes on power sources/Maintenance
- 41 Troubleshooting
- 44 Specifications
- 45 Index

## Getting Started

# Read this first

Before you use your phone, you must first set it up. Here's a quick way to set up your phone: Steps 1, 2, 3 and 4.

### Step 1 (page 7)

First, unpack the phone and the supplied accessories.

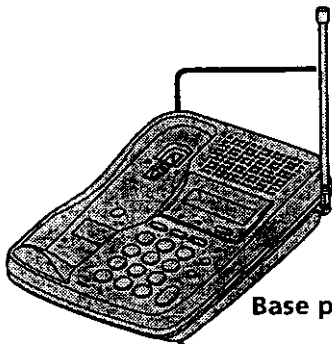

Base phone

### Step 2 (pages 8 to 10)

Next, you need to do three things to set up the base phone, including finding the best location for the base phone.

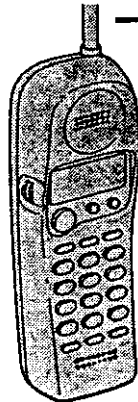

Handset

### Step 3 (pages 11 to 12)

Then, insert the battery pack into the handset and charge it for more than 12 hours.

### Step 4 (page 13)

Finally, enter your area code to use the Caller ID service.

***That's it!***

# Step 1

## Checking the package contents

Make sure you have received the following items in the package.  
If anything is missing, contact your local Sony dealer.

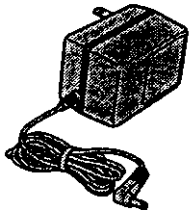

AC power adaptor (AC-T46)

↑ 確認済み

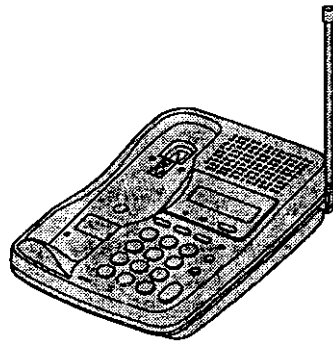

Base phone



Handset

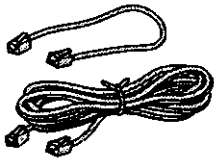

Telephone line cords (2)

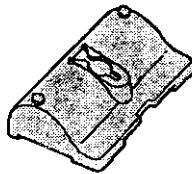

Wall bracket/stand for base phone

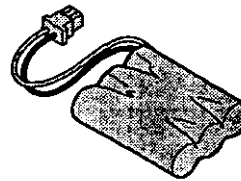

Rechargeable battery pack (BP-T24)

↑ 確認済み

## Step 2

### Setting up the base phone

Do the following steps:

- Choose the best location
- Connect the base phone
- Choose the dialing mode

#### Choose the best location

Where you place the base phone affects the reception quality of the handset.

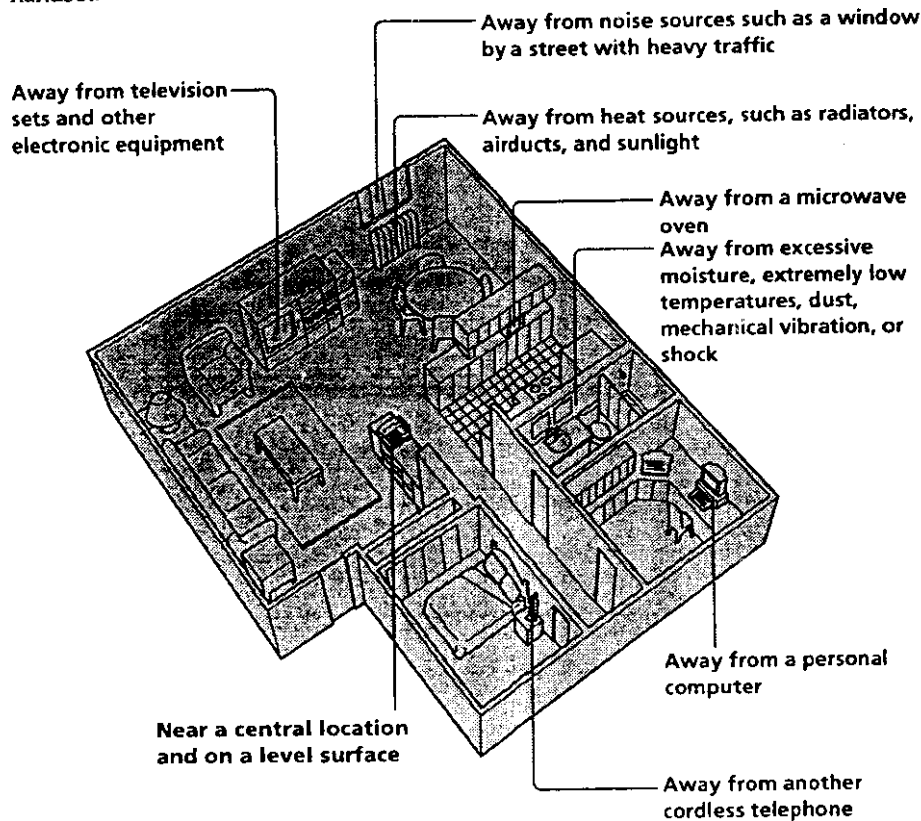

#### CAUTION

The cordless telephone operates at a frequency that may cause interference to nearby TVs and VCRs; the base phone should not be placed near or on the top of a TV or VCR; and, if interference is experienced, moving the cordless telephone farther away from the TV or VCR will often reduce or eliminate the interference.



## Connect the base phone

If you want to hang the base phone on the wall, see page 39.

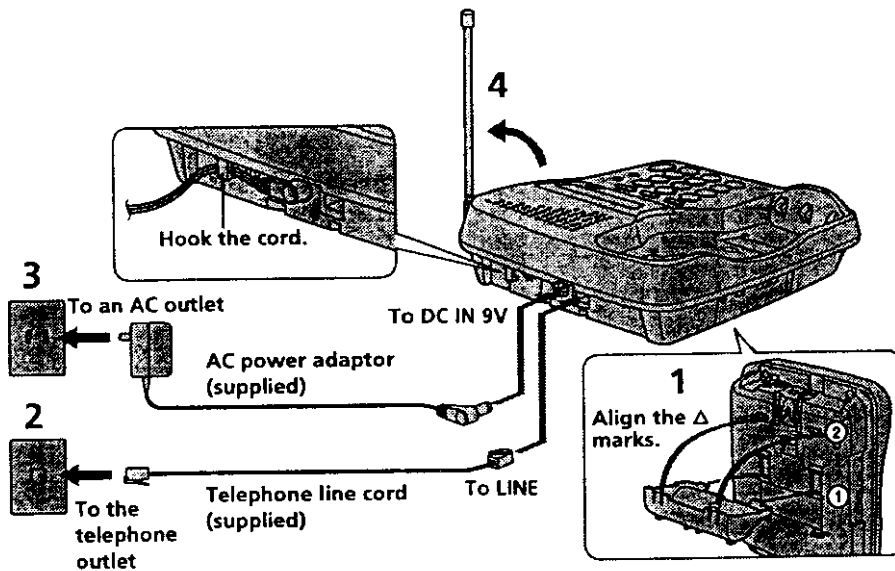

- 1 Attach the wall bracket to the bottom of the base phone as illustrated to use it as a stand.
- 2 Connect the telephone line cord to the LINE jack and to a telephone outlet.
- 3 Connect the AC power adaptor to the DC IN 9V jack and to an AC outlet.
- 4 Raise the antenna. Make sure it points towards the ceiling.

continued

Getting Started 9<sup>th</sup>

## Step 2: Setting up the base phone (continued)

### Notes

- Use only the supplied AC-T46 AC power adaptor. Do not use any other AC power adaptor.
- Connect the AC power adaptor to a continuous power supply.
- Place the base phone close to the AC outlet so that you can unplug the AC power adaptor easily.

### Polarity of the plug



### Tips

- If your telephone outlet isn't modular, contact your telephone service company for assistance.
- To remove the wall bracket, press in the upper tab.

### Modular



## Choose the dialing mode

For the telephone to work properly, select an appropriate dialing mode (tone or pulse).

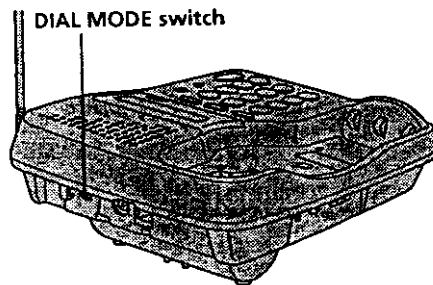

Depending on your dialing system, set the DIAL MODE switch as follows:

If your dialing system is	Set the switch to
Tone	T
Pulse	P

### If you aren't sure of your dialing system

Make a trial call with the DIAL MODE switch set to T. If the call connects, leave the switch as is; otherwise, set to P.

## Step 3

### Preparing the battery pack

Charge the battery pack for more than 12 hours before you start using your phone.

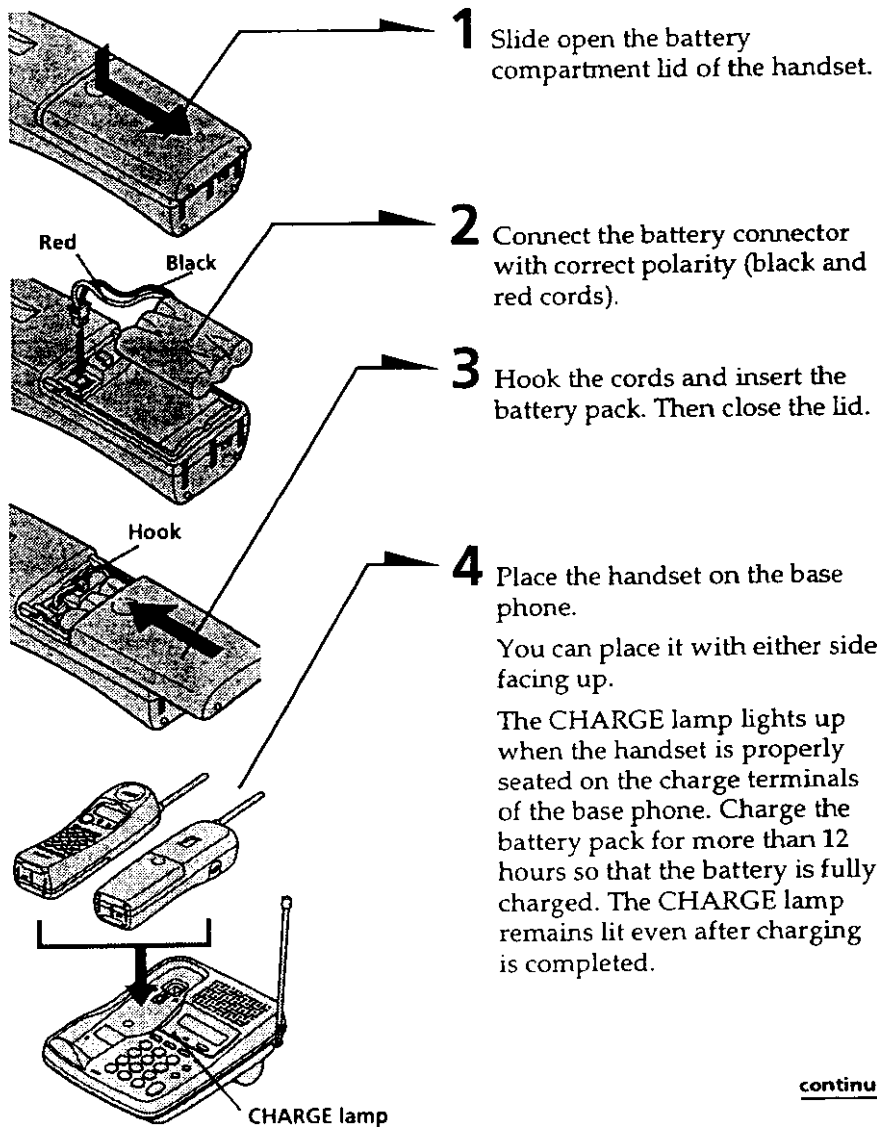

### Step 3: Preparing the battery pack (continued)

#### Battery duration

A fully charged battery pack lasts for about:

- 6 hours when you use the handset continuously
- 10 days (RING ON mode) or 4.5 weeks (BATT SAVE mode) when the handset is in standby mode.

#### Notes

- The battery pack will gradually discharge over a long period of time, even when not in use.
- To obtain the best handset performance, place the handset on the base phone for charging after several calls.
- If you leave the battery pack in the handset without charging it, the battery pack will be completely discharged.  
It may require several times of charging to recover to its full capacity.

← 471117171. 371717171.

#### When to purchase a new battery pack

If the battery lasts only a few minutes even after 12 hours of charging, the usable life of the battery has expired and needs replacement. Contact your local Sony authorized dealer or service center, and ask for a Sony BP-T24 rechargeable battery pack.

## Step 4

### Entering your area code

When you use this phone for the first time, or move to an area that has a different area code, you must enter your area code.

This is necessary because the phone must be able to distinguish between local or long distance calls to properly dial calls from the Caller ID list.

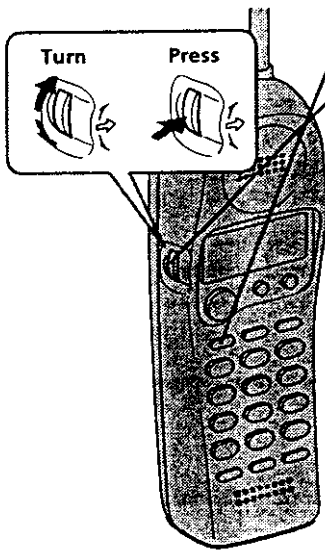

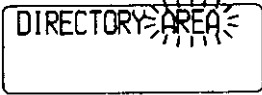
- 1 Press **PGM/VOL**.
- 2 Turn Jog Dial up to make "AREA" flash.  

- 3 Press Jog Dial.  
"ENTER AREA CODE" appears on the display.
- 4 Enter your three digits area code using the dialing keys.
- 5 Press **PGM/VOL**.  
You'll hear a long confirmation beep.

#### Notes

- If an area code is already entered, it appears on the display in step 3. To enter a different area code, see "To change the area code" below.
- Do not allow more than 20 seconds to elapse between each step of the procedure.

#### Tips

- You may press Jog Dial instead of **PGM/VOL** in step 5.
- To check the current area code, perform steps 1 to 3 above. The area code appears on the display for 20 seconds.

#### To change the area code

- 1 Perform steps 1 to 3 above.  
The current area code appears on the display.
- 2 Turn Jog Dial down to erase the current area code.
- 3 Enter a new area code using the dialing keys.
- 4 Press **PGM/VOL**.

You'll hear a long confirmation beep.

Getting Started 13<sup>th</sup>

## Basics

# Making calls

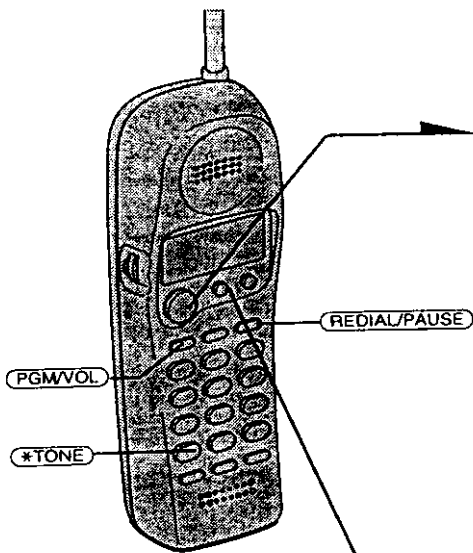

**1** Pick up the handset from the base phone.

**2** Press **TALK** and wait until "TALK" appears on the display. You'll then hear a dial tone.

The LINE lamp on the base phone lights up and the display shows the operation duration in hours, minutes and seconds.

If you hear beeps and "OUT OF RANGE" appears on the display, move closer to the base phone.

**3** Dial the phone number.

**4** When you're done talking, press **OFF** or place the handset on the base phone.

The display and the LINE lamp on the base phone go off.

### Additional tasks

To	Do this
Adjust the handset volume	During phone conversations, press <b>PGM/VOL</b> . Each press of <b>PGM/VOL</b> switches the speaker volume by one of four levels.
Put a call on hold	Press <b>HOLD</b> . The LINE lamp on the base phone flashes. Press the button again to resume the conversation.
Switch to tone dialing temporarily	Press <b>*TONE</b> after you're connected. The line will remain in tone dialing until disconnected.

#### Notes

- If the handset beeps every second during conversation and "OUT OF RANGE" appears on the display, move closer to the base phone; otherwise, the call will be disconnected after one minute.
- While the base phone is in use, you can't make a call with the handset. If you press **(TALK)**, you will hear a busy tone.

#### If the battery becomes weak during a call

The handset will beep every three seconds five times and **(CALL)** and "BATTERY LOW" appears on the display. Finish your call and charge the battery pack.

**For optimum performance, charge the battery for a full 12 hours.**

Note that during the first 10 - 15 minutes of charging, the phone will be inactive, i.e., unable to make or receive a call.

After this initial 10 - 15 minutes, you **may** be able to use the phone, but the battery duration will be **very short**; thus it is recommended that you **fully charge** the battery before the next usage.

#### Making calls through the speakerphone

Press **(SPEAKERPHONE)** on the base phone.

"SPEAKERPHONE" appears on the display and the LINE lamp lights up. The display also shows the operation duration in hours, minutes and seconds.

Dial the phone number.

To adjust the speakerphone volume, slide the SPEAKER VOLUME control.

When you're done talking, press **(SPEAKERPHONE)** again.

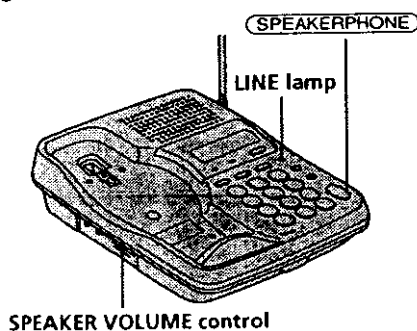

#### Notes

- While the handset is making a call, the display on the base phone shows "IN USE" and you can't make a call through the speakerphone. If you press **(SPEAKERPHONE)**, you will hear a busy tone.
- When the operation duration exceeds 9:59'59", the display counts from 0:00'00" again.

continued

Basics 15<sup>EN</sup>

## Making calls (continued)

### To obtain the best speakerphone performance

- You may not be able to hear the other party's voice in a noisy place. Therefore, use the speakerphone in a quiet room.
- Do not bring your hand or other object too close to the microphone or you will hear a shrill noise ("feedback").
- When the speaker volume is loud, or the base phone has been placed close to a wall, you may find that the volume drops suddenly. This is due to a circuit in the telephone designed to protect against feedback. In such cases, lower the speaker volume slightly.

### Redialing

- 1 Press **TALK** and wait until "TALK" appears on the display. The LINE lamp on the base phone lights up. If you're at the base phone, press **SPEAKERPHONE**. The LINE lamp lights up.
- 2 Press **REDIAL/PAUSE** to redial the last number dialed.

#### Note

If the number exceeds 32 digits, five short error beeps will alert you that the number can't be redialed.

#### Tip

The number to be redialed is the last number dialed either on the handset or on the base phone.

### To check the phone number before redialing

When not making a call with either the handset or base phone, press **REDIAL/PAUSE**.

The last number dialed is displayed for five seconds.

To dial the number, press **TALK** while the number is displayed. If you're at the base phone, press **SPEAKERPHONE**.

#### Note

The number will not be displayed if the last number dialed exceeds 32 digits or if it is erased.

### To erase the last phone number dialed

When not making a call with either the handset or base phone, press **REDIAL/PAUSE** twice within five seconds.

The number will be erased from the memory, and you'll hear a long confirmation beep.



# Receiving calls

QuickTalk "Bell in Key Answer" (この2機種 (964/640) 受信音のあり・なしを比較して、速答・動作が早い QuickTalk の受信音なし。二機種ともです。



**1** When you hear the phone ring:

- Press **(TALK)**.
- or
- Pick up the handset from the base phone when the handset is placed on the base phone.

"TALK" appears on the display and the LINE lamp lights up on the base phone. The display shows the operation duration in hours, minutes and seconds.

**2** When you're done talking, press **(OFF)** or place the handset on the base phone.

The display and the LINE lamp on the base phone go off.

## Additional tasks

To	Do this
Put a call on hold	Press <b>(HOLD)</b> . The LINE lamp on the base phone flashes. Press the button again to resume the conversation.
Switch to another call* ("call waiting" service)	Press <b>(CALL WAITING/FLASH)</b> ( <b>TALK</b> ). Press the button again to return to the first caller.

← 木の表示を  
二確認下さい。

\* You need to subscribe to this service from your telephone company.

### Note

If another call comes in by "call waiting" service while a call is on hold, you will hear two short beeps.

← 二確認下さい。

### Tip

To inform you of an incoming call, the display shows "\*\*RINGING\*\*" when ringing.

### If you have subscribed to the Caller ID service;

- the caller's number and/or name appears on the display when you receive a call (see page 32) or when another call comes in by "call waiting" service.
- the ringer sound changes to a higher tone if the call matches the number stored on ONE-TOUCH DIAL buttons, speed dialing keys or in the Phone Directory (memory match function; see page 32).

← "memory match function" は Base & handset は 別々の番号を (Base) 番号別々記述が必要になります。 (Base) の speed dialing には (あり) ます。

continued

Basics 17<sup>th</sup>

## Receiving calls (continued)

### To save battery power

Set the RING ON/BATT SAVE switch on the bottom to BATT SAVE.

The handset won't ring. You can still make calls, and also receive calls if another telephone connected to the same line rings to inform you of incoming calls, but you can't receive an intercom call.

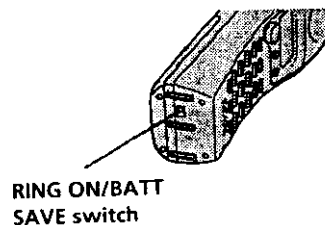

### Note

You cannot receive Caller ID data when the handset is off the base phone in BATT SAVE mode. See page 32 for details.

### Receiving calls through the speakerphone

When you hear the phone ring, press **SPEAKERPHONE** on the base phone.

"SPEAKERPHONE" appears on the display and the LINE lamp lights up. The display also shows the operation duration in hours, minutes and seconds.

When you're done talking, press **SPEAKERPHONE** again.

To obtain the best speakerphone performance, see page 16.

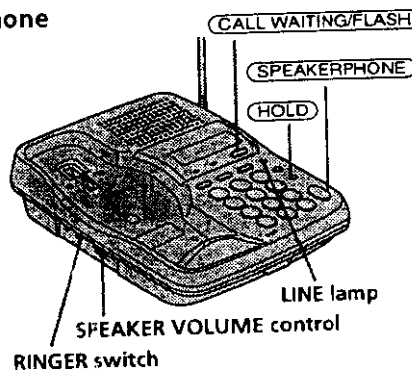

### Additional tasks

To	Do this
Put a call on hold	Press <b>HOLD</b> . The LINE lamp flashes. Press the button again to resume the conversation.
Switch to another call* ("call waiting" service)	Press <b>CALL WAITING/FLASH</b> . Press the button again to return to the first caller.
Adjust the speakerphone volume.	Slide the SPEAKER VOLUME control.
Turn on/off the ringer of the base phone	Set the RINGER switch to ON to turn the ringer on, or OFF to turn it off.

### Note

Even when you set the RINGER switch on the base phone to OFF, the handset will ring.

### Tip

To inform you of an incoming call, the display shows "\*\*RINGING\*\*" and the LINE lamp lights on and off according to the ring signal even when you set the RINGER switch to OFF.

## Telephone Features

# One-touch dialing

You can dial with one touch of a key by storing a phone number as a one-touch dial button.

## Storing phone numbers

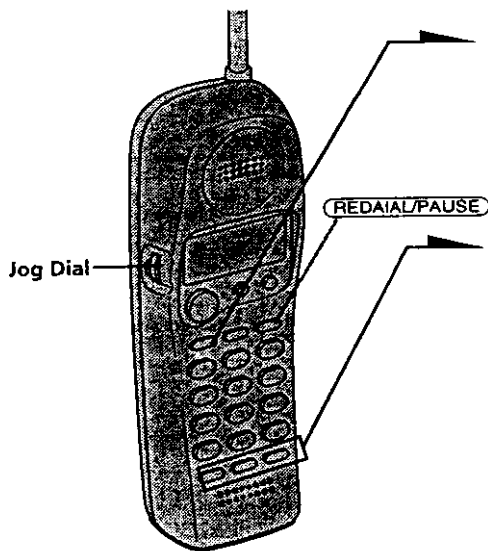

**1** Press (PGM/VOL).



**2** Press one of the three ONE-TOUCH DIAL buttons (A) to (C).  
You'll hear a confirmation beep.



If a number is stored, it appears on the display. To store a new number, turn Jog Dial to erase it.

**3** Enter the phone number you want to store.  
You can enter up to 16 digits, including a tone and a pause, each of which is counted as one digit.

**4** Press (PGM/VOL).  
You'll hear a long confirmation beep, and the number is stored. The display goes off.

continued

Telephone Features | 19<sup>EN</sup>

## One-touch dialing (continued)

### Note

Do not allow more than 20 seconds to elapse between each step of the procedure.

### Tips

- If you have entered a wrong number in step 3 and have not pressed **PGM/VOL** (step 4) yet, just turn Jog Dial down to erase it. Then, enter the correct number.
- You may press Jog Dial instead of **PGM/VOL** in step 4.

### To store a number to be dialed via Private Branch Exchange (PBX)

Before entering a phone number in Step 3 on page 19, do as follows:

- 1 Enter the outside line access digit (e.g., 9).
- 2 Press **REDIAL/PAUSE**.

### To change a stored number

- 1 Press **PGM/VOL**.
- 2 Press one of the ONE-TOUCH DIAL buttons (**A** to **C**).  
The current number appears on the display.
- 3 Turn Jog Dial down to erase the current number.
- 4 Enter a new number.
- 5 Press **PGM/VOL**.

### Note

You can replace the stored number with a new number, but you can't just erase it.

## Making calls with one-touch dialing

- 1 Press **TALK** and wait until "TALK" appears on the display.
- 2 Press one of the ONE-TOUCH DIAL buttons (**A** to **C**).

The phone number stored on the one-touch dialing button will appear on the display and will be dialed.

### To check the phone number before one-touch dialing

When not making a call with the handset, press one of the ONE-TOUCH DIAL buttons (**A** to **C**).

The number stored for that button appears on the display for five seconds. To dial the number, press **TALK** while the number is displayed.

## Speed dialing

You can dial with a touch of a few keys by storing a phone number as a dialing key.

### Storing phone numbers

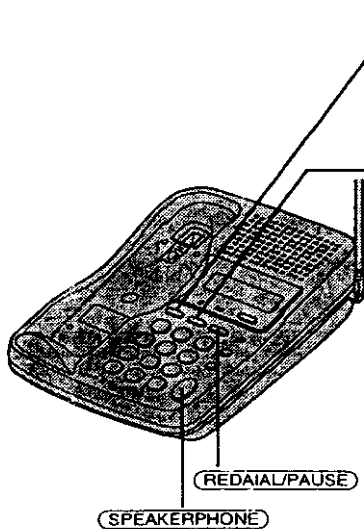

- 1** Press **(PGM)**.  
"PROGRAM" appears on the display.
- 2** Press **(SPEED DIAL)**.  
"ENTER 0 TO 9" appears on the display.
- 3** Press one of the dialing keys (**(0)** to **(9)**) to store a phone number on.  
You'll hear a confirmation beep.
- 4** Enter the phone number you want to store.  
You can enter up to 16 digits, including a tone and a pause, each of which is counted as one digit.
- 5** Press **(PGM)**.  
You'll hear a long confirmation beep, and the number is stored.

Telephone Features

#### Note

Do not allow more than 20 seconds to elapse between each step of the procedure.

#### Tips

- If you enter a wrong number, press **(PGM)**, then start from the beginning.
- Use the supplied directory to write down what you stored on the speed dialing numbers.

continued

Telephone Features | 21<sup>EN</sup>

---

## Speed dialing (continued)

### To store a number to be dialed via Private Branch Exchange (PBX)

Before entering a phone number in Step 4, do as follows:

- 1 Enter the outside line access digit (e.g., 9).
- 2 Press **REDIAL/PAUSE**.

### To change a stored number

Store a new number, as described previously.

## Making calls with speed dialing

- 1 Press **SPEAKERPHONE**.
- 2 Press **SPEED DIAL**.
- 3 Enter the desired speed dialing number (**0** to **9**).

The phone number stored as the speed dialing number will be dialed.

### To check the phone number before speed dialing

When not making a call with the base phone, press **SPEED DIAL** and then one of the dialing keys (**0** to **9**).

The number stored on the key appears on the display for five seconds. To dial the number, press **SPEAKERPHONE** while the number is displayed.

# Phone Directory

You can dial a number by scrolling through the Phone Directory, in which up to 50 phone numbers can be stored.

## Storing phone numbers and names

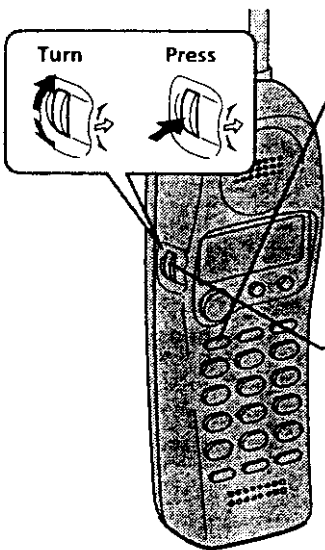

Example: to store "SONY" "123-4567".

**1** Press **PGM/VOL**.

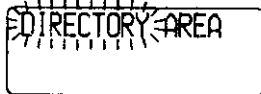

If "DIRECTORY" is not flashing, turn Jog Dial down to make it flash.

**2** Press Jog Dial.  
"ENTER NAME" appears.

**3** Enter the name using the dialing keys. You can enter up to 15 characters.

Press a dialing key until the desired character appears. (See the character table for details.)

Enter successive characters in the same way.

To enter two characters assigned to the same key, or to enter a "space", turn Jog Dial up to move the cursor to the right.

**Example:** to enter "SONY", press **7** four times (S), press **6** three times (O), turn Jog Dial up to move the cursor, press **6** twice (N), and press **9** three times (Y).

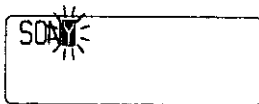

### Character table

Key	Character
①	1
②	A → B → C → 2
③	D → E → F → 3
④	G → H → I → 4
⑤	J → K → L → 5
⑥	M → N → O → 6
⑦	P → Q → R → S → 7
⑧	T → U → V → 8
⑨	W → X → Y → Z → 9
0	0
*	*
#	#

Telephone Features

continued

Telephone Features | 23<sup>EN</sup>

## Phone Directory (continued)

**4** Press **PGM/VOL**.  
"ENTER NUMBER" appears.

**5** Enter the phone number.  
You can enter up to 16 digits, including a tone and a pause, each of which is counted as one digit.

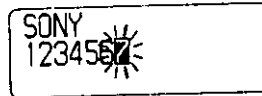

**6** Press **PGM/VOL**.  
You'll hear a long confirmation beep, and the name and the number are stored. The display goes off.

### Notes

- If you intend to save a 51st phone number, you will hear five short error beeps and "MEMORY FULL" will be displayed. You cannot store the phone number. To store another phone number, erase one of the stored phone numbers (see page 25).
- Do not allow more than 20 seconds to elapse between each step of the procedure.

### Tips

- If you have entered a wrong name or number in step 3 or 5, turn Jog Dial down to erase it. Then enter the correct name or number.
- You may press Jog Dial instead of **PGM/VOL** in steps 4 and 6.
- To store a number to be dialed via PBX, follow the steps on page 20 when entering a phone number.

## Changing a stored name and/or phone number

**1** Display the name and phone number you want to change by doing steps 1 and 2 on page 23.

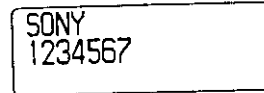

**2** Press Jog Dial.

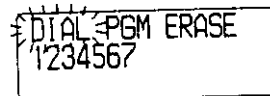



- 3** Turn Jog Dial up to make "PGM" flash and press Jog Dial.

The cursor flashes at the last character of the name.

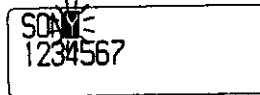

- 4** Turn Jog Dial down to erase the characters and enter the new name.

If you want to change only the number, skip this step.

- 5** Press Jog dial.

The cursor flashes at the last digit of the phone number.

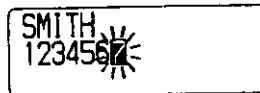

- 6** Turn Jog Dial down to erase the number and enter the new number.

If you don't want to change the number, skip this step.

- 7** Press Jog Dial.

You'll hear a long confirmation beep and the name and/or the number is changed.

### Erasing a memory location

- 1** Display the name and phone number you want to erase by doing steps 1 and 2 on page 23.

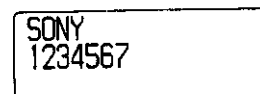

- 2** Press Jog Dial.

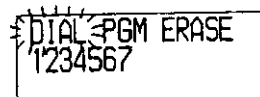

- 3** Turn Jog Dial up to make "ERASE" flash and press Jog Dial.

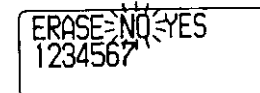

- 4** Turn Jog Dial up to make "YES" flash, then press Jog Dial.

You hear a long confirmation beep and the memory location is erased.

Telephone Features

continued

## Phone Directory (continued)

### Making calls from the Phone Directory

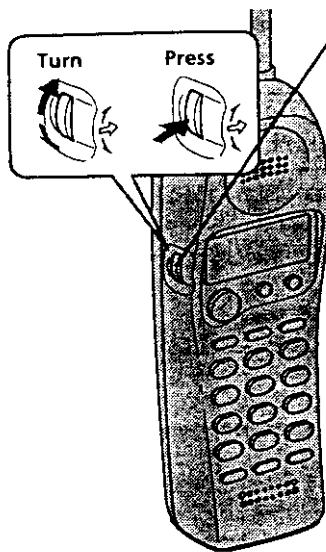

**1** Press Jog Dial twice.  
"DIRECTORY" appears on the display.

**2** Display the name and phone number you want to call.  
**To search in alphabetical order:** Turn Jog Dial up or down.

**To search by entering the initial character:** Press the dialing key of the desired character, then turn Jog Dial.

SONY  
1234567

**3** Press Jog Dial.

DIAL PGM ERASE  
1234567

**4** Press Jog Dial again.

The phone number will be dialed.

#### Tip

You may press **TALK** to make a call instead of doing steps 3 and 4.

#### About the search order

The names appear in the following order when you turn Jog Dial up or down.

- Alphabetical order: ABC...XYZ ↔ symbols\* ↔ \* ↔ # ↔ 0 - 9

\* Symbols appear only when you have stored the number having the symbol from the Caller ID list.

- Initial character: To search for "SONY" for example, press **7** and then turn Jog Dial to search through the names starting with P, Q, R, S or 7.

## Switching the phones during a call

You can easily switch between the handset and speakerphone on the base phone without disconnecting the call.

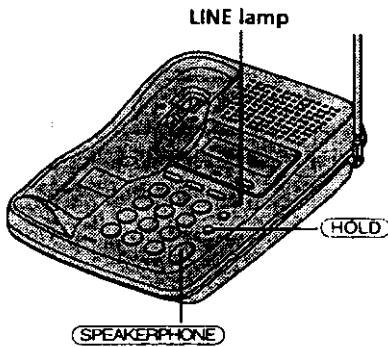

### To switch from the base phone to the handset

- 1 Press **(HOLD)** on the base phone.  
The call is on hold and the LINE lamp flashes.
- 2 Press **(TALK)** or **(HOLD)** on the handset.  
You can continue talking to the caller through the handset.

### To switch from the handset to the base phone

- 1 Press **(HOLD)** on the handset.  
The call is on hold and the LINE lamp flashes.
- 2 Press **(SPEAKERPHONE)** or **(HOLD)** on the base phone.  
You can continue talking to the caller through the speakerphone.

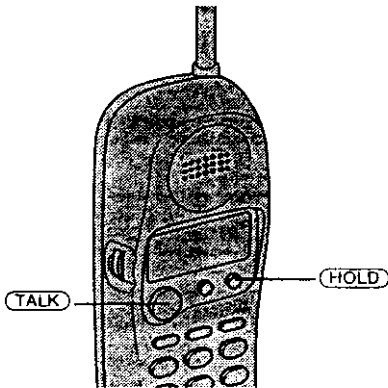

#### Tips

- While talking through the speakerphone on the base phone, if you pick up the handset, the call will be switched to the handset.
- When the call is put on hold on the base phone, if you pick up the handset, the call will be switched to the handset.

## Talking between the phones (Intercom)

You can hold an intercom conversation using the base phone and the handset. You can start the intercom from either phone.

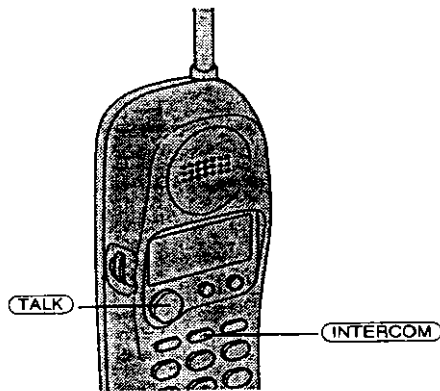

### To talk from the handset to the base phone

Press **INTERCOM**.

The base phone rings.

When a person at the base phone presses **SPEAKERPHONE** or **INTERCOM**, you can talk with each other.

← 401-3と404を  
baseの403と404を  
又に3と404に  
てはうか。

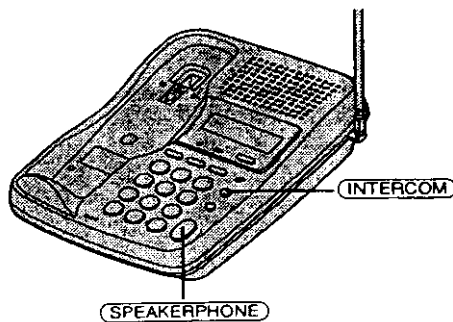

### To talk from the base phone to the handset

Press **INTERCOM**.

The handset rings.

When a person at the handset presses **TALK** or **INTERCOM**, you can talk each other.

### If no one answers the phone

Press **INTERCOM** again.

#### Notes

- You can't receive an intercom call on the handset when its RING ON/BATT SAVE switch is set to BATT SAVE.
- If there's an incoming call while on the intercom, only the base phone rings. To answer the call, press **INTERCOM** on the base phone. The intercom is canceled and you can talk to the outside caller.

## Voice paging

The handset user can page someone near the base phone without any operation on the base phone. Neither phones will ring.

Note that you can't page if the base phone is in use.

### To page with voice



1 Press **PGM/VOL**.

2 Press **INTERCOM**.

You'll hear a confirmation beep. "INTERCOM" appears on the display of both the base phone and handset, and you can begin talking.

#### Note

If there's an incoming call during voice paging, only the base phone rings. To answer the call, press **INTERCOM** on the base phone. The paging is canceled and you can talk to the outside caller.

## Transferring a call

You can transfer a call between the handset and base phone while the call is on hold.

### To transfer from the base phone to the handset

**1** Ask the outside caller to wait while you transfer the call.

← 必要なし

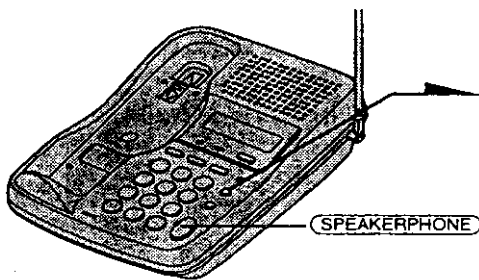

**2** Press **INTERCOM** to page the handset.

The call is put on hold on the base phone and the handset rings. "PAGING" appears on the display of both the base phone and handset.

**3** Press **TALK** or **INTERCOM** on the handset.

"INTERCOM" appears on the display of both the handset and base phone.

You can talk between the base phone and the handset.

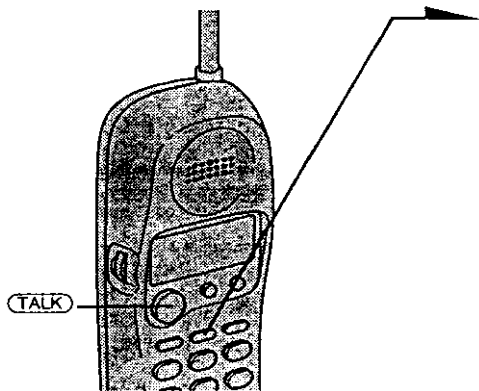

**4** To talk to the caller with the handset:

- Press **INTERCOM** on the handset.

or

- Press **SPEAKERPHONE** on the base phone.

#### Note

You can't receive an intercom call on the handset when its RING ON/BATT SAVE switch is set to BATT SAVE.

#### Tips

- If you have accidentally pressed **HOLD** in step 2, just press **INTERCOM** and you will get the same result as by pressing **INTERCOM** only.
- The LINE lamp on the base phone flashes during intercom.

## To transfer from the handset to the base phone

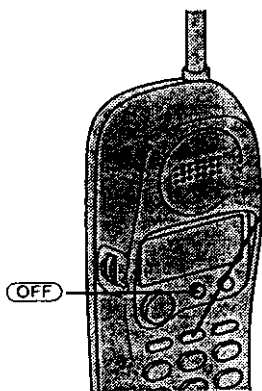

**1** Ask the outside caller to wait while you transfer the call.

**2** Press **INTERCOM** to page the base phone.

The call is put on hold on the handset and the base phone rings. "PAGING" appears on the display of both the handset and base phone.

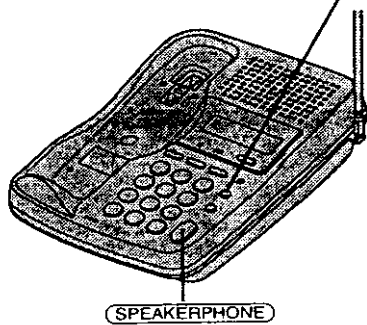

**3** Press **SPEAKERPHONE** or **INTERCOM** on the base phone.

"INTERCOM" appears on the display of both the base phone and handset.

You can talk between the handset and the base phone.

**4** To talk to the caller with the base phone

- Press **INTERCOM** on the base phone.

or

- Press **OFF** on the handset.

### Tip

You can receive an intercom call on the base phone even when the RINGER switch on the base phone is set to OFF. The base phone will ring at a low level.

## Caller ID Features

# Understanding the Caller ID service

Caller ID allows the caller's phone number to be shown on the display before the call is answered. In order to use this feature, you must first subscribe to the Caller ID service. The name of this service may vary depending on your telephone company.

To use this feature, be sure to enter your area code (see page 13).

## When you receive a call

The phone number appears on the display with the date and time\* as shown in the following example.

If your Caller ID service includes the caller name service, the caller's name also appears on the display (up to 15 letters).

Caller's name	SMITH JOHN
Caller's phone number	1-201-123-4567
The date and time received	7:04 PM 4:53

When you answer the call, the Caller ID display changes to the "TALK" or "SPEAKERPHONE" display.

\* The display on the base phone doesn't show the date and time.

### Notes

- If the RING ON/BATT SAVE switch is set to BATT SAVE:
  - when the handset is off the base phone, the Caller ID is not displayed, and it is not kept in the Caller ID list (see page 33). If you set it back to RING ON while the phone is ringing, the Caller ID appears.
  - when the handset is on the base phone, the Caller ID is displayed, and it is kept in the Caller ID list.
- The caller's phone number and/or name will not appear in the following cases:
  - "OUT OF AREA": when the call is made through a telephone company which does not offer Caller ID service (including international calls).
  - "PRIVATE": when the call is "blocked." For privacy reasons, many states allow callers the option to prevent his or her telephone data from being displayed on the other party's Caller ID display.
- If the call is from an office which uses multiple lines, the displayed phone number may not match the number you use to call the extension.

## About the memory match function

If you receive a call from a phone number which is stored as one of the ONE-TOUCH DIAL buttons (see page 19), Speed Dialing keys (see page 21) or in the Phone Directory (see page 23), the ringer sound will change to a higher tone from the second ring.

### Note

The memory match function does not work with "OUT OF AREA" or "PRIVATE" calls; and it may not work with calls made from an office which uses multiple lines because the number does not always match the one you stored in this phone.



## Looking at the Caller ID list

The phone stores the data of the last 20 calls received including "OUT OF AREA" and "PRIVATE" calls. It keeps track of all calls received; even if they were not answered.

However, if the RING ON/BATT SAVE switch is set to BATT SAVE when the handset is off the base phone, the phone can't receive the Caller ID data.

### Viewing the Caller ID list

You can look through the Caller ID list to check the phone number and/or name of the calls received on the handset's display. Note that the display on the base phone shows the current caller's phone number and/or name only, and you can't view the caller ID list on the base phone.

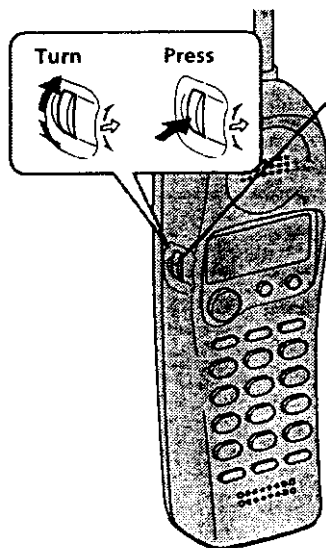

- 1 Press Jog Dial.

The display shows the number of "NEW" (calls which you have not viewed) and "OLD" (calls which you have viewed) calls.

NEW 08 OLD 12

- 2 Turn Jog Dial.

The data of the newest call appears for 20 seconds.

SMITH JOHN  
1-201-123-4567  
NEW 08 7:04 PM 4:53

- 3 Turn Jog dial down to display older data or up to display newer data.

Caller ID Features

continued

## Looking at the Caller ID list (continued)

### Note

If a 21st call is received, the oldest data is automatically erased.

### Tips

- You can also view the Caller ID list during a conversation by following the steps above.
- If there is a "NEW" data, the NEW CALL lamp of the base phone flashes.

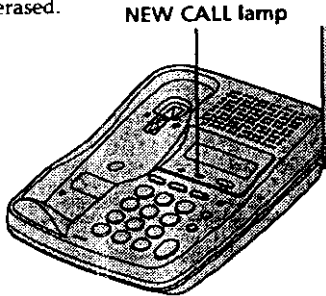

### About the "\*" mark

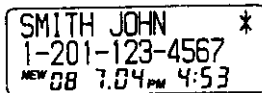

"\*" appears if there are more than two calls from the same phone number. The older data will be replaced by the new data, so the calls are counted as only one call.

## Erasing data from the Caller ID list

Old data will be erased automatically when a 21st call comes in, but you can also manually erase unnecessary data one by one or erase the entire list.

### To erase the phone number one by one

- 1 Display the phone number you want to erase from the Caller ID list (see page 33).
- 2 Press Jog Dial.
- 3 Turn Jog Dial up to make "ERASE" flash and press Jog Dial.
- 4 Turn Jog Dial up to make "YES" flash, then press Jog Dial.  
You'll hear a long confirmation beep and the data is erased.

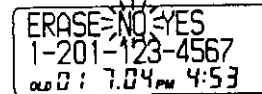
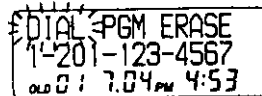
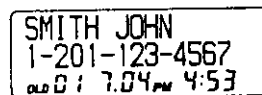

**To erase the entire list at once**

**1** Display any Caller ID data.

```
SMITH JOHN  
1-201-123-4567  
OLD 01 7:04 PM 4:53
```

**2** Press Jog Dial.

```
DIAL PGM ERASE  
1-201-123-4567  
OLD 01 7:04 PM 4:53
```

**3** Turn Jog Dial up to make "ERASE" flash and press Jog Dial.

```
ERASE NO YES ALL  
1-201-123-4567  
OLD 01 7:04 PM 4:53
```

**4** Turn Jog Dial up to make "ALL" flash, then press Jog Dial.

```
ALL ERASE NO YES  
1-201-123-4567  
OLD 01 7:04 PM 4:53
```

**5** Turn Jog Dial up to make "YES" flash, then press Jog Dial.

```
NEW 00 OLD 00
```

You'll hear a long confirmation beep and the entire list is erased.

**Note**

"ALL" appears only when all the data has become "OLD" data. If there is any "NEW" data, you can't erase the entire list.

# Using the Caller ID list

By using the Caller ID list, you can call back a phone number from the Caller ID list easily, or store numbers from the Caller ID list into memory dialing keys.

## Calling back a number from the Caller ID list

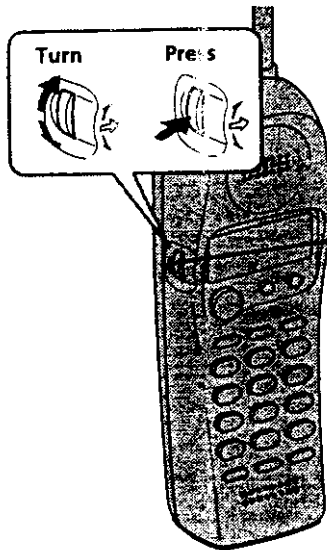

- 1 Display the phone number you want to call from the Caller ID list (see page 33).

SMITH JOHN  
1-201-123-4567  
NEW 08 7:04 PM 4:53

- 2 Press Jog dial.

DIAL PGM ERASE  
1-201-123-4567  
NEW 08 7:04 PM 4:53

- 3 Press Jog dial again.

The phone automatically dials the displayed number.

### Note

If the phone is connected to a Private Branch Exchange (PBX), you may not be able to call back from the Caller ID list because an outside line access digit is necessary.

### Tip

You may press **TALK** to make a call instead of doing steps 2 and 3.

### To change the Caller ID number

xxxxxxxxxxxxxxxxxx.

Caller ID番号の検索  
画面に入力して  
内容を削除する。→  
挿入位置はここから開始。

このマニュアルのp.38に相当するところに  
123-4567 入力しよう。

④

## Storing a number of the Caller ID list into the Phone Directory

**1** Display the name and phone number you want to store from the Caller ID list (see page 33).

SMITH JOHN  
1-201-123-4567  
NEW DB 7:04 PM 4:53

**2** Press Jog Dial.

DTAL PGM ERASE  
1-201-123-4567  
NEW DB 7:04 PM 4:53

**3** Turn Jog Dial up to make "PGM" flash and press Jog Dial.

The cursor flashes at the end of the name.

Enter or change the name, if necessary (see page 24)

SMITH JOHN  
12011234567

**4** Press Jog Dial.

The cursor flashes at the end of the phone number.

Enter or change the phone number, if necessary (see page 24).

SMITH JOHN  
12011234567

**5** Press Jog Dial again.

You'll hear a long confirmation beep and the name and number are stored.

### Notes

- Do not allow more than 20 seconds to elapse between each step of the procedure.
- If the phone is connected to a Private Branch Exchange (PBX), you may need to add an outside line access digit.

## Using "Caller ID with call waiting" service

This telephone is compatible with the "Caller ID with call waiting" service. Make sure that your telephone company offers this service.

Like the basic Caller ID service, you need to subscribe to "Caller ID with call waiting" in order to use this service.

Even though you may have already subscribed to "Caller ID" and "call waiting" as two separate services, you need to request a subscription to "Caller ID with call waiting" as a single service.

This is a new service that combines the two services.

Even though you now have a "Caller ID with call waiting" compatible phone, unless you subscribe to the combined "Caller ID with call waiting" service, you will not be able to see the name and number of the second caller.

When a new call comes in while you are talking, the caller's name and/or phone number of the new call appears on the display for about 20 seconds.

### To switch to another caller



- 1** To switch to the new caller, press **CALL WAITING/FLASH** (TALK).
- 2** To switch back to the first caller, press **CALL WAITING/FLASH** (TALK) again.

## Additional Information

# Mounting the base phone on a wall

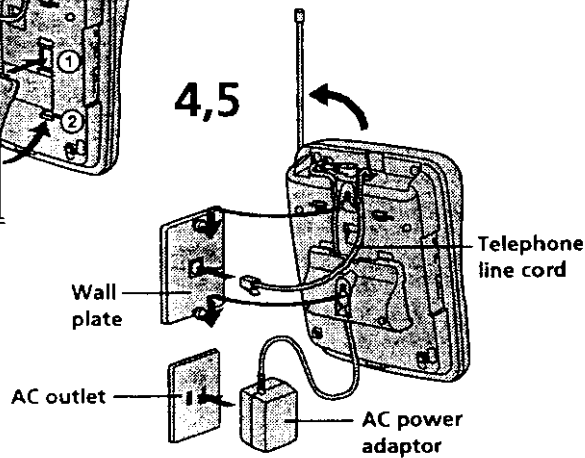
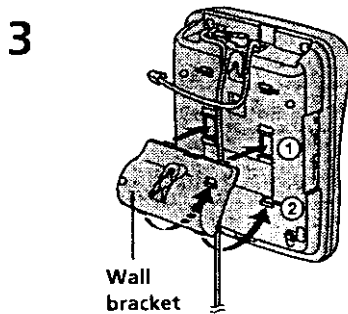
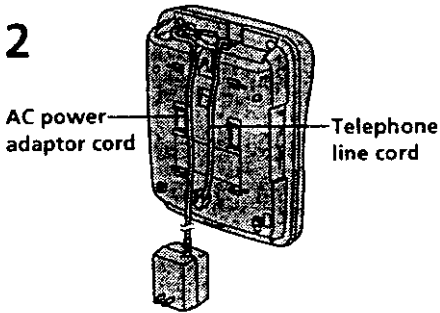
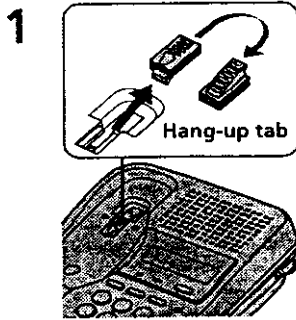

**Tip**  
To remove the wall bracket, press the lower tabs.

1 Reverse the hang-up tab.

2 Plug the telephone line cord to the LINE jack and the AC power adaptor to the DC IN 9V jack, and hook the cords. Use the shorter cord for mounting.

3 Attach the wall bracket to the center of the base phone.  
Align the  $\Delta$  marks of the wall bracket with those of the base phone.

4 Plug the telephone line cord to the telephone outlet, and hook the base phone to the wall plate.

5 Plug the AC power adaptor to an AC outlet. Then raise the antenna so that it points towards the ceiling.

Additional Information

Additional Information 39<sup>FN</sup>

## Notes on power sources

### On battery pack

- Store the battery pack at a temperature between 41°F (5°C) and 95°F (35°C) for best performance.
- If you do not use the handset for a long period of time, remove the battery pack after charging for more than 12 hours.

### On power failure

During a power interruption, you cannot make or receive calls.

### RECYCLING NICKEL-CADMIUM BATTERIES



NICKEL-CADMIUM BATTERY. BATTERY MUST BE RECYCLED OR DISPOSED OF PROPERLY.

### Ni-Cd

Nickel-Cadmium batteries are recyclable. You can help preserve our environment by returning your unwanted batteries to your nearest Sony Service Center for collection, recycling or proper disposal.

**Note:** In some areas the disposal of nickel-cadmium batteries in household or business trash may be prohibited.

For the Sony Service Center nearest you call 1-800-222-SONY (United States only)

**Caution:** Do not handle damaged or leaking nickel-cadmium batteries.

## Maintenance

- Clean the cabinets with a soft cloth slightly moistened with water or a mild detergent solution. Do not use any type of abrasive pad, scouring powder or solvent such as alcohol or benzine as they may damage the finish of the cabinet.
- If the charge terminals of the base phone and handset are soiled, wipe them with a soft cloth or paper.

If you have any questions or problems concerning your phone, please consult your nearest Sony dealer.

40<sup>EM</sup> Additional Information

SS965を流用して  
いすかや過不足はあり  
ていすかや。



# Troubleshooting

If you've experienced any of the following difficulties while using your phone, use this troubleshooting guide to help you remedy the problem. Should any problem persist, consult your nearest Sony dealer.

	Symptom	Remedy
Making calls	You hear five short error beeps when you press <b>TALK</b> .	<ul style="list-style-type: none"> <li>• Make sure you have set up the base phone correctly (page 8).</li> <li>• Move the handset closer to the base phone.</li> </ul>
	You hear no dial tone.	<ul style="list-style-type: none"> <li>• Make sure the telephone line cord is securely connected to the telephone outlet.</li> <li>• Make sure the battery is fully charged (page 11).</li> </ul>
	The phone doesn't connect at all, even though the number you dial is correct.	<ul style="list-style-type: none"> <li>• Make sure the dialing mode is set correctly (page 10).</li> </ul>
	The phone doesn't redial correctly.	<ul style="list-style-type: none"> <li>• Make sure the last dialed number is really the one you want to dial.</li> </ul>
	You hear five short error beeps when you try to redial.	<ul style="list-style-type: none"> <li>• The number you last dialed exceeds 32 digits (including the tone and pause digits if used).</li> <li>• The number you last dialed is erased.</li> </ul>
Receiving calls	You can't perform the redial operations (redialing, checking and erasing the phone number), and "OUT OF RANGE" appears on the display.	<ul style="list-style-type: none"> <li>• Move the handset closer to the base phone and perform the redial operations again.</li> </ul>
	You can't hear anything from the speakerphone.	<ul style="list-style-type: none"> <li>• Slide the <b>SPEAKER VOLUME</b> control on the base phone to increase the speakerphone volume.</li> </ul>
	The handset doesn't ring.	<ul style="list-style-type: none"> <li>• Set the <b>RING ON/BATT SAVE</b> switch on the handset to <b>RING ON</b>.</li> <li>• The battery may be weak. Charge the battery for more than 12 hours (page 11).</li> <li>• Make sure you have set up the base phone correctly (page 8).</li> <li>• Move the handset closer to the base phone.</li> </ul>
During conversation	You hear interference during conversation.	<ul style="list-style-type: none"> <li>• Move the handset closer to the base phone.</li> <li>• Place the base phone away from noise sources (page 8).</li> </ul>
	You hear a beep every second during conversation and "OUT OF RANGE" appear on the display.	<ul style="list-style-type: none"> <li>• This is the out-of-range alarm. Move the handset closer to the base phone within one minute.</li> </ul>
	You hear a beep every three seconds and  and "BATTERY LOW" appears on the display.	<ul style="list-style-type: none"> <li>• The battery is weak. Charge the battery for more than 12 hours (page 11).</li> </ul>

continued

Additional Information 41<sup>EW</sup>

確認後 →

## Troubleshooting (continued)

	Symptom	Remedy
One-touch dialing/Speed dialing/Phone Directory	You hear five short error beeps and can't store a number as a one-touch dial, speed dialing key or in the Phone Directory.	<ul style="list-style-type: none"> <li>Make sure you follow the procedure for storing the number correctly (pages 19, 21 and 23).</li> </ul>
	You hear five short error beeps when you try to make a one-touch or speed dial call.	<ul style="list-style-type: none"> <li>You have entered a one-touch dialing button or speed dialing key for which no phone number has been stored.</li> </ul>
	One-touch dialing, speed dialing or Phone Directory dialing is incorrect.	<ul style="list-style-type: none"> <li>Store the correct number (pages 19, 21 and 23).</li> </ul>
Intercom	The handset doesn't ring when you use the intercom from the base phone.	<ul style="list-style-type: none"> <li>Set the RING ON/BATT SAVE switch to RING ON.</li> <li>The battery may be weak. Charge the battery for more than 12 hours (page 11).</li> <li>Extend the antenna of the base phone vertically.</li> <li>Move the handset closer to the base phone.</li> <li>Place the base phone away from noise sources (page 8).</li> </ul>
Caller ID	The caller's name and/or phone number does not appear on the display.	<ul style="list-style-type: none"> <li>Make sure you have subscribed to Caller ID service.</li> <li>Caller ID service may not work when the phone is connected to a Private Branch Exchange (PBX).</li> <li>Make sure that the handset is on the base phone or is set to RING ON (page 32).</li> <li>The call is made through company which does not offer Caller ID service. "OUT OF AREA" will appear on the display.</li> <li>The call was "blocked." "PRIVATE" will appear on the display.</li> <li>You have answered the call while "**RINGING**" was displayed. Be sure to answer after the Caller ID data is displayed.</li> </ul>
	The caller's name and/or phone number does not appear on the display during call waiting.	<ul style="list-style-type: none"> <li>Make sure you have subscribed to "Caller ID with call waiting" service (see page 38).</li> <li>Make sure nobody is talking with another phone on the same telephone line.</li> </ul>
	You cannot dial the number from the Caller ID list.	<ul style="list-style-type: none"> <li>Make sure you entered your area code correctly (page 13).</li> <li>This function may not work when the phone is connected to a Private Branch Exchange (PBX).</li> </ul>
	The memory match function does not work.	<ul style="list-style-type: none"> <li>If the call is from an office which uses multiple lines, the phone number may not match the number you put in the memory.</li> <li>If you have stored the phone number with an outside line access digit in the Phone Directory because the phone is connected to a Private Branch Exchange (PBX), the phone number will not match the Caller ID data.</li> </ul>

42<sup>EN</sup> Additional Information

Power source/battery

The CHARGE lamp doesn't light up when you place the handset to charge.

- Wipe the charge terminals of the base phone and the handset with a soft cloth or paper for better contact of the charge terminals.
- Make sure the handset is placed on the base phone properly.

The battery duration is short.

- The battery pack was charged less than 12 hours (due to power failure, etc.).
- The usage life of the battery has expired and needs replacement.

**Notes**

- If any of these remedies do not work, there may be something wrong with the handset.  
Replace the handset on the base phone, then pick it up and try again. If the handset is on the base phone, pick up the handset and replace it again.
- Should any problems persist, press **RESET** on the left side of the base phone with a ball-point pen, etc. This has no effect on the memory in the base phone and handset.

← 故障解除

Additional Information

Additional Information 43<sup>EN</sup>

# Specifications

## General

Spread method  
Direct-Sequence Spread-Spectrum

Access method  
FDMA-TDD

Frequency band  
902 - 928 MHz

Operating channel  
20 channels

Dial signal  
Tone, 10 PPS (pulse) selectable

Supplied accessories  
See page 7.

## Handset

Power source  
Rechargeable battery pack BP-T24

Battery life  
Standby: Approx. 10 days (RING ON Mode)  
Approx. 4.5 weeks (BATT SAVE mode)

Talk: Approx. 6 hours

Dimensions  
Approx. 58 x 177 x 46 mm (w/h/d), antenna excluded  
(approx. 2 3/8 x 7 x 1 13/16 inches)  
Antenna: 72 mm (2 7/8 inches)

Mass  
Approx. 250 g (approx. 8.8 oz), battery included

## Base phone

Power source  
DC 9V from AC power adaptor

Battery charging time  
Approx. 12 hours

Dimensions  
Approx. 128 x 58 x 208 mm (w/h/d), antenna excluded  
(approx. 5 1/8 x 2 3/8 x 8 1/4 inches)  
Antenna: 165 mm (6 1/2 inches)

Mass  
Approx. 320 g (approx. 11 oz), wall bracket excluded

Design and specifications are subject to change without notice.

数字直拨: 免分机号.

# Index

## A

Adjusting volume  
  handset volume 14  
  speakerphone volume 18  
Area code 13

## B

Battery pack  
  charging 11  
  duration 12  
Battery save (BATT SAVE)  
mode 18

## C

Call waiting service 17  
Caller ID 32  
  Caller ID list 33  
  calling back 36  
  Memory match function 32  
  storing in Phone Directory 37  
Caller ID with call waiting 38  
Connection 9

## D

Dialing mode  
  choosing 10  
  switching to the tone temporarily 14  
Directory  
  Phone Directory 23

## E, F, G

Erasing  
  Caller ID data 34  
  last phone number dialed 16  
  Phone Directory 23

## H

Hold 14

## I, J, K

Intercom 28

## L

Location, base phone 8

## M, N

Making calls 14  
Memory match function 32  
Mounting the base phone on a wall 39

## O

One-touch dialing 19  
OUT OF AREA 32

## P, Q

Package contents 7  
Phone Directory 23  
PRIVATE 32  
Pulse dialing 10

## R

Receiving calls 17  
Redialing 16  
Ringer  
  RING ON/BATT SAVE switch 18

## S

Setting up  
  base phone 8  
  handset 11  
Speakerphone 15  
Speed dialing 21  
Storing Caller ID data in Phone Directory 37  
Switching phones during a call 27

## T, U

Talking between the phones 28  
Tone dialing  
  dialing mode 10  
  switching to 14  
Transferring a call 30  
Troubleshooting 41

## V, W, X, Y, Z

Voice paging 29  
Volume  
  handset 14  
  speakerphone 18

Additional Information