

SONY

***UHF Synthesized
Wireless Microphone***

Operating Instructions

GB

WRT-807B

Owner's Record

The model and serial numbers are located at the rear of the unit. Record the serial number in the space provided below. Refer to these numbers whenever you call upon your Sony dealer regarding this product.

Model No. WRT-807B

Serial No. _____

Notice for customers in the U.S.A.

Use of Sony wireless devices is regulated by the Federal Communications Commission as described in Part 74 subpart H of the FCC regulations and users authorized thereby are required to obtain an appropriate license.

You are cautioned that any changes or modifications not expressly approved in this manual could void your authority to operate this equipment.

Notice for customers in Canada:

Use of Sony wireless devices is regulated by the Industry Canada as described in their Radio Standard Specification RSS-123.

A licence is normally required. The local district office of Industry Canada should therefore be contacted. When the operation of the device is within the broadcast band, the licence is issued on no-interference, no-protection basis with respect to broadcast signals.

Operation of this device is subject to the following two conditions: (1) this device may not cause interference, and (2) this device must accept any interference, including interference that may cause undesired operation of the device.

Avis pour les clients au Canada:

L'usage des appareils sans-fil Sony est régi par l'Industrie Canada comme décrit dans leur Cahier des Normes Radioélectriques CNR-123.

Une licence est normalement requise. Le bureau de l'Industrie Canada doit être contacté. Lorsque l'opération de l'appareil est dans les limites de la bande de radiodiffusion, la licence est émanée sur la base de non-interférence, non-protection avec les signaux de radiodiffusion.

L'utilisation de cet appareil est soumise aux deux conditions suivantes : (1) cet appareil ne peut causer d'interférences, et (2) cet appareil doit accepter toutes les interférences, y compris les interférences capables de provoquer un fonctionnement indésirable de l'appareil.

Precautions	1
Introduction	2
Transmitting Channel Band	2
Features	2
Parts Identification	4
Power Supply	7
Settings	8
Initiating Setting Mode	8
Changing the Transmitting Channel	8
Changing the Input Attenuation Setting	10
Resetting the Accumulated Battery Use Time Indication	11
Troubleshooting	12
Specifications	14
Error Messages	15

- The unit is designed for use in ambient temperature range of 0°C to 50°C (32°F to 122°F).
- Do not place the unit on or near heat sources, such as lighting equipment, power amplifiers, or in a place subject to direct sunlight or excessive moisture. In such places, the external finish or internal parts of the unit may be damaged.
- If the unit is used in a very humid or dusty place or in a place subject to an active gas, clean its surface as well as the connectors with a dry, soft cloth soon after use. Lengthy use of the unit in such places or not cleaning it after its use in such places may shorten its life.
- When cleaning the unit, never use organic solvents such as thinners or benzine, which will damage the finish of the unit.
- The unit has been factory adjusted precisely. Do not tamper with its internal parts or attempt to repair it.
- Do not attempt to recharge an alkaline battery.
- Do not dispose of a battery in fire. Do not disassemble or short-circuit a battery.
- Make sure to use an LR6 (size-AA) alkaline battery.
- Make sure the poles of the battery match the + and - markings in the battery holder.
- Remove the battery when the unit will not be used for a long period of time.

Introduction

The WRT-807B is a UHF-synthesized wireless microphone for use in a 800-MHz band UHF-synthesized wireless microphone system.

The WRT-807B operates in conjunction with the MB- X6 with WRU-806B UHF Synthesized Tuner Unit for vocal concentration.

The WRT-807B can be also used with existing Sony wireless microphone systems consisting of the WRT-805B/855B UHF Synthesized Transmitter and WRR-805B/855B/862B UHF Synthesized Tuner, etc.

Transmitting Channel Band

The microphone/transmitter and tuners of wireless microphone systems are classified by frequency band.

A 24-MHz frequency band is assigned to each microphone/transmitter and tuner model.

In building a UHF wireless microphone system, be sure to pair a microphone/transmitter with a tuner that has the same TV channel number.

Features

Phase Locked Loop (PLL) synthesized system

The WRT-807B features a refined phase locked loop (PLL) synthesizer circuit.

POWER switch with holding function

The POWER switch can be locked in the ON position to protect against accidental power cut-offs.

Low-battery notification on tuner

When the microphone battery is low, the microphone sends a warning to the WRR-805B/862B/WRU-806B in the form of "Battery status information."

This information is sent to the WRR-805B/862B/WRU-806B about one hour before the battery goes dead to allow the battery to be safely replaced.

When the WRR-805B/862B/WRU-806B receives this information, the LED on tuner panel starts to flash.

Powered by readily available battery type

The built-in, high-efficiency DC-DC converter provides about 5 hours of continuous and stable operation with just a single LR6 (size-AA) alkaline battery.

LCD readout of various information

The microphones LCD shows the current channel number, frequency, input attenuation setting, and residual battery power.

The accumulated battery use time is also indicated (in one-minute increments) to allow precise monitoring of battery use.

Automatic saving of channel and input attenuation settings

All channel and input attenuation settings are automatically saved when the microphone is turned off (and are maintained even when the battery is removed), thus eliminating the need to make the same settings again the next time you use the microphone.

Highly reliable electronic attenuator

Adjustable in a range of 0 dB to 21 dB in 3-dB steps, the built-in input level attenuator reduces signal distortion during the input of excessively strong audio signals.

Tone signal-incorporated RF carrier signal

The microphone transmits an RF carrier signal that incorporates a tone signal to enable any tuner with a tone squelch circuit to pick out only the target audio signal.

Wide dynamic range and low noise

The microphones compander (compressor/expander) system enables transmission over a wide dynamic range with minimum noise.

Notes on operation

- When operating two or more microphones, keep the microphones separated from each other by a distance of at least 30 cm (1 foot).
- Keep microphones at least 3 meters (10 feet) away from the receiving antenna.

Parts Identification

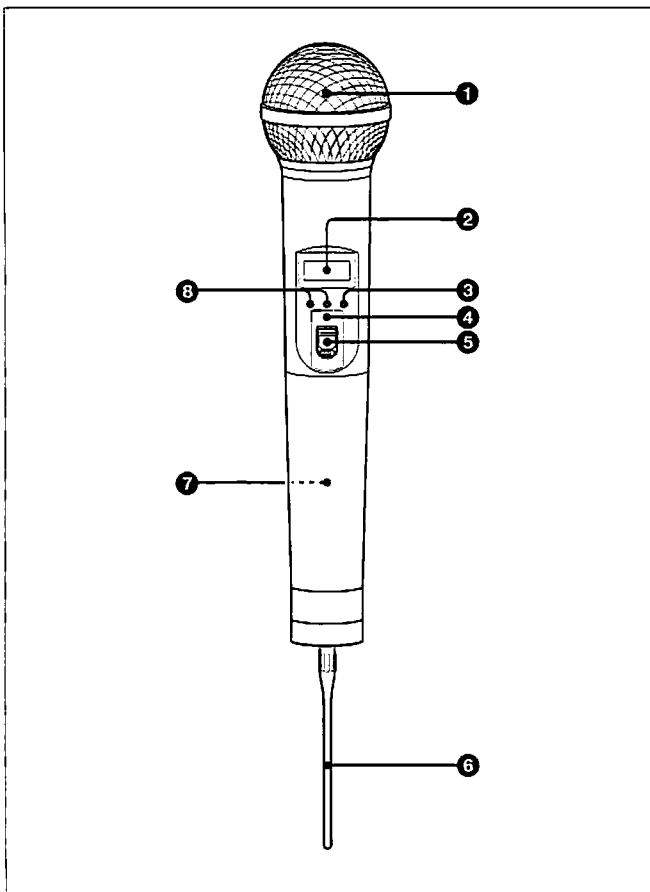

4(GB)

① Wind screen

Protects against noise caused by wind.

② Liquid-crystal display

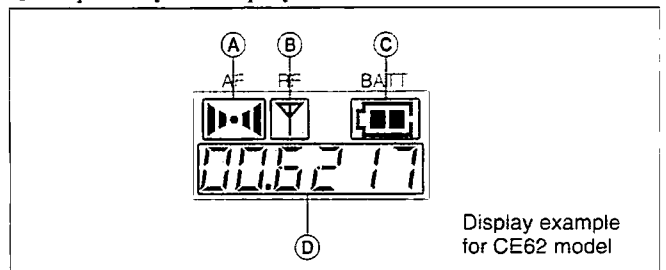

Ⓐ AF (audio input) indication

Lights whenever an audio signal stronger than the reference level is received.

Ⓑ RF (antenna output) indication

Lights during signal transmission from the antenna.

Ⓒ BATT (battery) indication

Shows the battery condition.

See "Battery indication" on page 7.

Ⓣ CH (channel) indication

Displays the transmitting channel.

Each time you press the SET button in Transmit mode, the channel indication changes as follows.

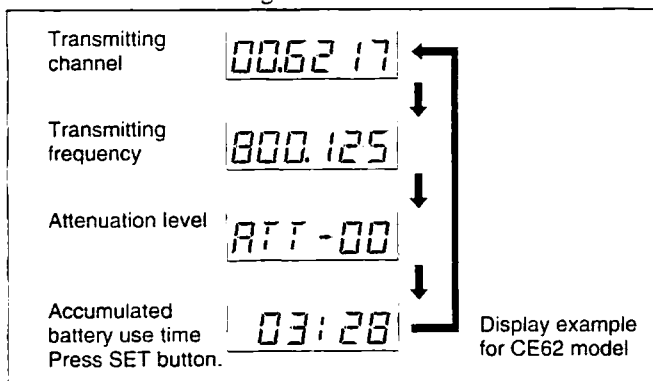

Transmitting channel: The current transmitting channel setting.

Transmitting frequency: The current transmitting frequency setting.

Attenuation: The input attenuation setting in decibels. Can be set within a range of 0 dB to 21 dB in 3-dB steps.

Accumulated battery use time: The accumulated time of battery use (in 1-minute increments).

To adjust these parameters, see "Changing the transmitting Channel" on page 8, "Changing the Input Attenuation Setting" on page 10 or "Resetting the Accumulated Battery Use Time Indication" on page 11.

Ⓢ SET button

In Transmit mode, press this button to change the indicated items in the lower half of the liquid-crystal display.

To change to Setting mode, turn the POWER switch to ON while holding this button down. Then press this button to select the items to be indicated.

How to press the SET and +/- buttons

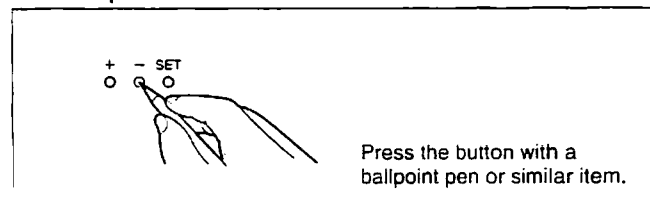

For details on Setting mode, see "Settings" on page 8.

Parts Identification

④ POWER indicator

Lights when the microphone is on.

⑤ POWER switch

Turns the microphone ON or OFF.

When you set this switch to ON without holding down any other button, the microphone enters Transmit mode, and the signal of the selected channel is transmitted.

The HOLD switch appears when the POWER switch is set to ON.

Set the HOLD switch to the lock position to prevent an accidental power cut-off during microphone operation.

⑥ Antenna

⑦ Battery holder

Insert the battery here.

For details on inserting the battery, see "Power Supply" on page 7.

⑧ + (+ selection) / – (– selection/reset) buttons

In Setting mode, use these buttons to select the transmitting channel and attenuation level, and use the – button to reset the accumulated battery use time indication to 00:00.

For details on Setting mode, see "Settings" on page 8.

Locking the POWER switch

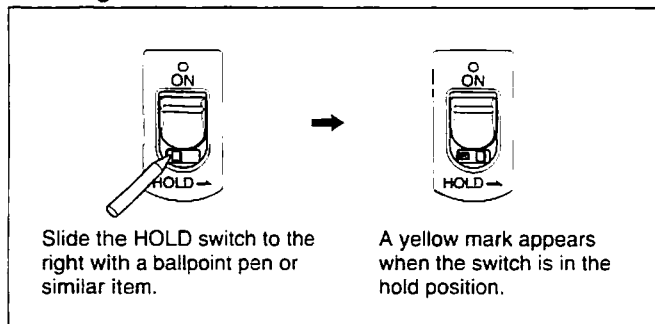

Power Supply

The microphone can operate on one LR6 (size AA) alkaline battery continuously for about 5 hours at 25 °C (77°F).

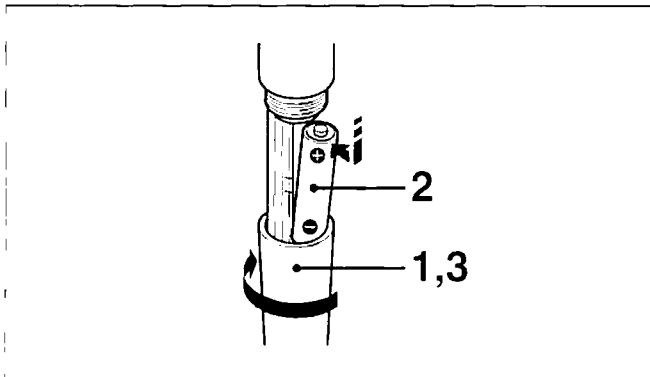

Inserting the battery



- 1 Turn the grip in the direction of the arrow to open the battery holder.
- 2 Match the battery to the polarity markings and insert it into the battery holder.
- 3 Close the battery holder and lock the grip by turning it in the opposite direction of the arrow.

Battery indication

When you turn the power on, the battery condition is indicated by the BATT indication in the liquid-crystal display.

	1	2	3	4
BATT indication	Lights 	Lights 	Flashes 	Goes off
Battery condition	Good	Less than half-charge	Almost exhausted	Completely exhausted

Note

The indication may be incorrect if the battery was not new when inserted. If you plan to use the microphone for a long period, replace the battery with a new one.

Settings

Initiating Setting Mode

Enter Setting mode to change the transmitting channel, the transmitting frequency and the attenuation level, or to reset the accumulated battery use time indication.

To enter Setting mode

While holding down the SET button, turn the POWER switch to ON.

Hold the SET button down until an indication appears on the liquid-crystal display.

The microphone enters Setting mode and the indication before the microphone was previously turned OFF flashes on the liquid-crystal display.

Pressing the SET button cycles the modes in the order of Channel selection mode, Frequency selection mode (page 9), Attenuator adjustment mode (page 10) and Accumulated time indication reset mode (see page 11).

Note

On the model available in Europe, the transmitting channels are grouped in four sets as shown in "Sony Wireless Microphone System Frequency List."

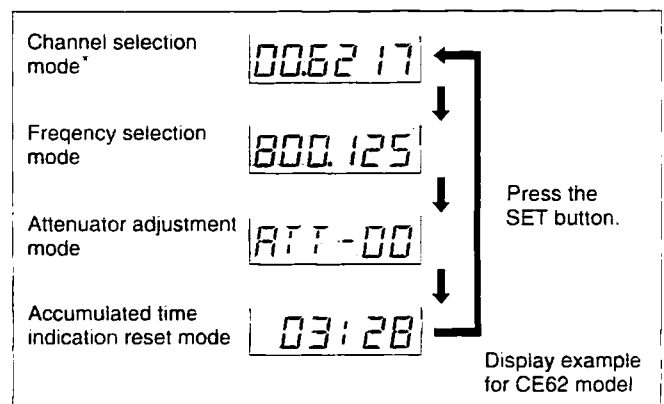

* On the model available in Europe, set the channel group indication (the left two digits) first. Press the + or - button to toggle the channel group (e.g., for CE62 model: 00 ↔ 62 ↔ 63 ↔ 64) and press the SET button. Then, the remaining four digits start to flash for setting the channel number.

Changing the Transmitting Channel

The transmitting channel can be selected through either the channel number or the frequency.

- 1 Set the microphone to Setting mode.
If the channel number (or frequency) indication does not appear, press the SET button until the channel number (or frequency) indication appears.

- 2** Press the + or – button to select the channel number (or frequency).

Pressing the + button cycles the indication in the order shown in separate “Sony Wireless Microphone System Frequency List.” Pressing the – button cycles the indications in the opposite direction.

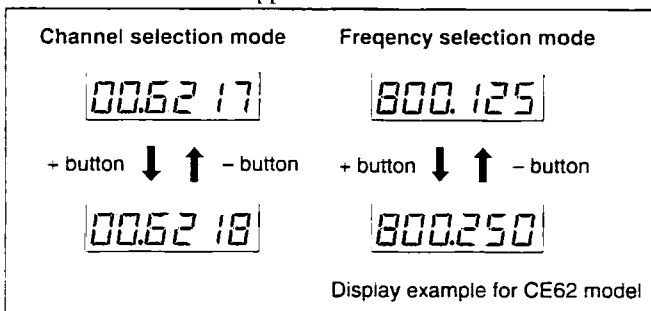

Hold down the button to change the channel number (or frequency) quickly.

- 3** When the desired channel number (or frequency) appears, turn the POWER switch to OFF to release Setting mode, or press the SET button to continue operations in Setting mode.

The next time you turn on the microphone (by turning the POWER switch to ON), the microphone will enter Transmit mode with the selected channel number (or frequency).

Notes

- The microphone cannot transmit in Setting mode.
- Make sure that the channel selected on the microphone is the same as that selected on the tuner being used in the same system.
- Depending on the noise or interference conditions, all selectable channels may not be usable. If necessary, you can determine which channels are usable by cycling the channel selection through a number of channels on the tuner with the microphone set to OFF. Those channels for which the RF indicator on the tuner does not light are usable.
- The microphone may not operate correctly if it is turned on immediately after being turned off in Setting mode. Wait for a few seconds before turning the power on again.

Setting

Changing the Input Attenuation Setting

The input attenuation setting can be changed within a range of 0 dB to 21 dB (in 3-dB steps) in either Setting mode or Transmit mode.

Changing the input attenuation in Setting mode

- 1 Set the microphone to Setting mode.
- 2 If the attenuation level is not displayed, press the SET button until it appears.
- 3 Press the + or – button to change the attenuation setting.

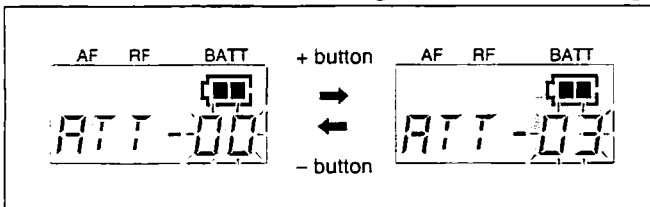

Hold down the button to change the level quickly.

- 4 Once the desired level appears, turn the POWER switch to OFF to release Setting mode, or press the SET button to continue operations in Setting mode.

10(GB)

The next time you turn on the microphone (by turning the POWER switch to ON), the microphone enters Transmit mode with the selected attenuation setting.

Changing the input attenuation in Transmit mode

You can also change the input attenuation setting while transmitting in Transmit mode.

- 1 If the attenuation level is not displayed, press the SET button until it appears.
- 2 Press the + or – button to change the attenuation setting.

Resetting the Accumulated Battery Use Time Indication

- 4 Turn the POWER switch to OFF to release Setting mode.

The accumulated battery use time is the total time (in hours and minutes) the battery has been used. It is recorded whenever the WRT-807B is on. Reset the indication to 00:00 whenever you replace the battery.

- 1 Set the microphone to Setting mode.
- 2 If the accumulated battery use time is not displayed, press the SET button until it appears.
- 3 Press the – button. The indication resets to 00:00.

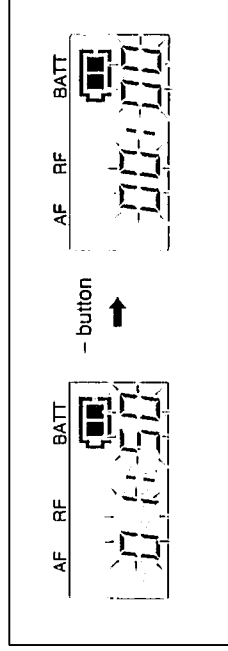

Press the + button while the 00:00 indication is on to go back to previous value.

Troubleshooting

If you have any problem using this unit, use the following checklist. Should any problem persist, consult your Sony dealer.

Symptom	Meaning/Remedy
The microphone does not turn on.	<ul style="list-style-type: none"> • The + and – poles of the battery do not match those of the battery compartment. ➔ Insert the battery with the poles correctly matched. • The battery is exhausted. ➔ Replace the battery with new one. • The battery terminals in the microphone are dirty. ➔ Clean the + and – terminals with a cotton swab.
The battery runs down quickly.	<ul style="list-style-type: none"> • The battery is exhausted. ➔ Replace the battery with new one. • A manganese battery is being used. ➔ Use an alkaline battery. The battery life of a manganese battery is less than half that of an alkaline battery. • The microphone is being used under cold conditions. ➔ The battery runs down quickly under cold conditions.
The microphone cannot be turned off.	The HOLD switch is in locked position. ➔ Change the HOLD switch to the unlocked position.
The channel cannot be changed.	An attempt was made to change the channel by pressing the SET button only. ➔ Turn the microphone off, then turn the microphone on again while holding down the SET button. Then change the channel with the + and – buttons.
There is no sound.	<ul style="list-style-type: none"> • The indication on the LCD is flashing. ➔ The microphone is in channel setting mode. Turn the power off, then on again. • The channel setting on the microphone is different from that on the tuner. ➔ Use the same channel setting for both the microphone and tuner. • The AF or RF indicator does not turn on. ➔ Confirm that the microphone and tuner are both turned on.

Symptom	Meaning/Remedy
The sound is weak.	<ul style="list-style-type: none"> • The attenuation level setting is too high. ➔ The output level is low. Press the – button in attenuation level setting mode to lower the attenuation level. • The volume on the amplifier, mixer or tuner is low. ➔ Adjust the volume.
There is distortion in the sound.	The attenuation level setting is too low. ➔ The input level is extremely high. Press the + button in attenuation level setting mode to raise the attenuation level.
There is sound interruption or noise.	<ul style="list-style-type: none"> • The receiver's antenna is incorrectly connected. ➔ Connect the antenna correctly according to the operation manual of the tuner or antenna divider. • The antenna divider is turned off. ➔ Turn the antenna divider on. It is possible for the tuner to receive signals even when the antenna divider is turned off, but sound interruption or noise may occur. • The RF indicator lights even when the microphone is off. ➔ Jammed transmissions are being received. Determine which channels are usable (i.e., channels for which the RF indicator on the tuner does not light) and set the tuner and microphone to the same usable channel. • Two or more microphones are set to the same channel. ➔ Make sure no two microphones are set to the same channel. Set each microphone to a different channel.

Specifications

Transmitter and modulator section

Oscillator	Crystal controlled PLL synthesizer
Type of emission	F3E
Carrier frequencies	566.125 – 607.875 MHz 614.125 – 805.875 MHz

RF power output	10 mW (50-ohm load)
Tone signal	32.768 kHz
Battery condition signal	32.782 kHz
Type of antenna	1/4 -wavelength wire

Audio section

Microphone type	uni-directional dynamic microphone
Pre-emphasis	50 μ s
Deviation	± 5 kHz (94 dB _{SPL} ¹⁾ , 1 kHz input)
Frequency response	50 to 15,000 Hz
Signal-to-noise ratio	57 dB or more (A-weighted, modulation frequency 1 kHz, with ± 5 kHz deviation at WRU-806B with MB-806A)
Audio attenuator	0 to 21 dB, variable in 3-dB steps
Input level	151 dB _{SPL} (at audio attenuator 21 dB)

Power section

Power requirements	1.5 V DC (one LR6/size AA alkaline battery)
Battery life	Approx. 5 hours at 25°C or 77°F, with Sony LR6 alkaline battery

General

Operating temperature	0°C to +50°C (32°F to 122°F)
Storage temperature	-30°C to +60°C (-22°F to +140°F)
Dimensions	51 × 238 mm (diameter/length) not including antenna (2-1/8 × 9-3/8 inches)
Mass	Approx. 440 g (15.5 oz) including battery

Supplied accessory

Operating Instructions (1)
Sony Wireless Microphone System Frequency List (1)
Microphone holder (1)
Stand adaptor (PF 1/2 to W 3/8) (for CE57/62/67 model) (1)
Stand adaptor (PF 1/2 to NS 5/8) (for U62/66 model) (1)
Channel color seal (1)

Design and specifications are subject to change without notice.

1) 0 dB_{SPL} = 2×10^{-5} Pa

Specifications

Standard frequency response

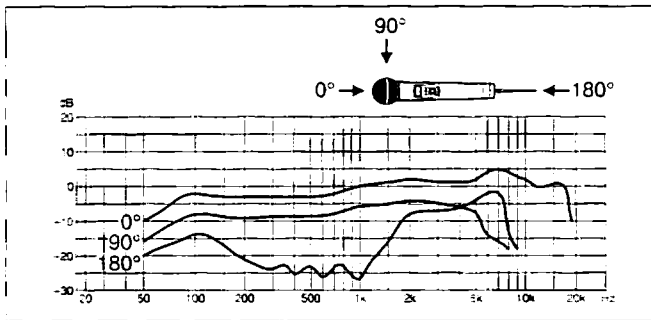

Standard directivity response

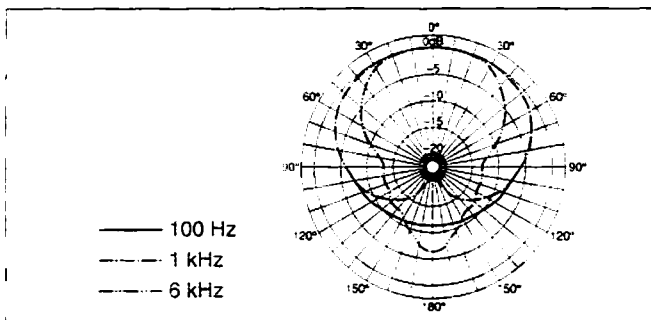

Error Messages

When a problem occurs, one of the following error messages may appear on the display.

Message	Contents	Measures
Error 11	An error occurred in backup memory data.	The data was initialized. Set the transmitting channel and the input attenuation again.
Error 21	The PLL synthesized circuit is in trouble.	Contact your Sony dealer.
Error 31	The battery voltage exceeds the allowable value.	Use the specified battery.
Error 41	Defect of an internal circuit.	Contact your Sony dealer.
Error 51	Defect of the A/D converter circuit.	
Error 61	Defect of an internal circuit.	