

Device basics

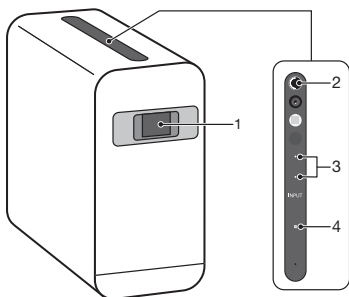

- 1 Projection window (Laser aperture)
- 2 Power key
- 3 Volume keys
- 4 NFC

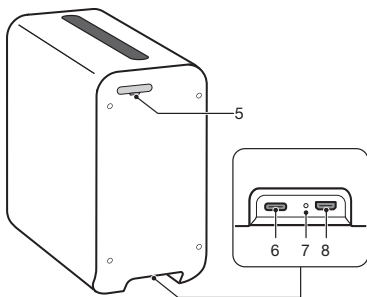

- 5 Memory card tray
- 6 Charger/USB Type-C™ cable port
- 7 LED indicator
- 8 HDMI™ Type-D port

To insert the memory card

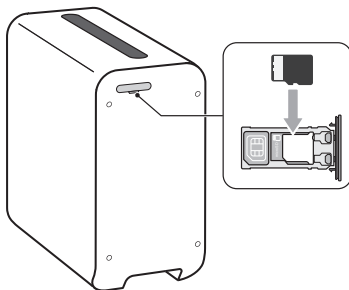

- 1 Drag out the memory card tray using your fingernail.
- 2 Firmly place the memory card in the correct orientation into the tray as shown in the illustration.
- 3 Gently push the tray back into the slot until it fits into place.

To turn on the device

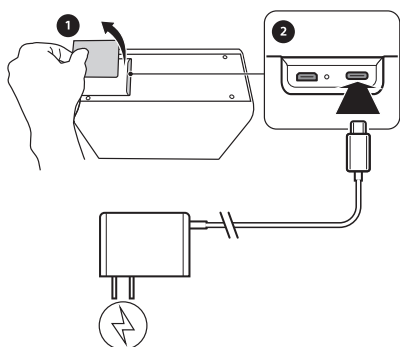

⚠ It is important to use the provided USB Type-C charger when charging your device, as other types of USB chargers may damage or not charge your device.

- 1 Remove the slot cover as show in the illustration.
- 2 Plug the power cable into its slot as shown in the illustration.
- 3 Gently reattach the slot cover.
- 4 Plug the charger into the power outlet. The LED indicator next to the power cable slot lights up briefly. Make sure to remove the protection film from the front of the device before using it.
- 5 Press and hold the power key until the volume buttons light up.

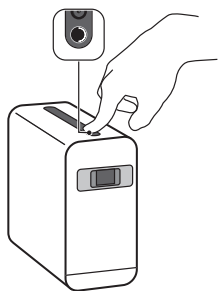

💡 The projection starts approximately 30 seconds after the device is turned on. To turn off the device, press and hold the power key then tap power off on the touchscreen.

To project the touchscreen

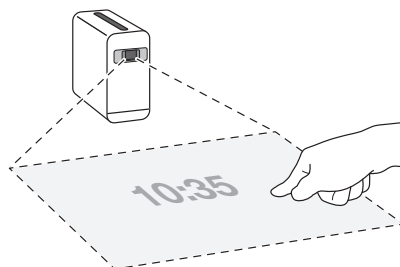

- 1 Place the device on a clean, flat, horizontal surface as shown in the illustration. Make sure that there are no obstructions in the projection area.
 - 2 Navigate the projected screen using your finger.
- ! The device will automatically pause projection if it is moved or lifted during operation.
 - 💡 The first time you start your device, a setup guide helps you to configure basic settings, personalise your device and sign in to your accounts, for example a Google™ account.

To project onto a wall

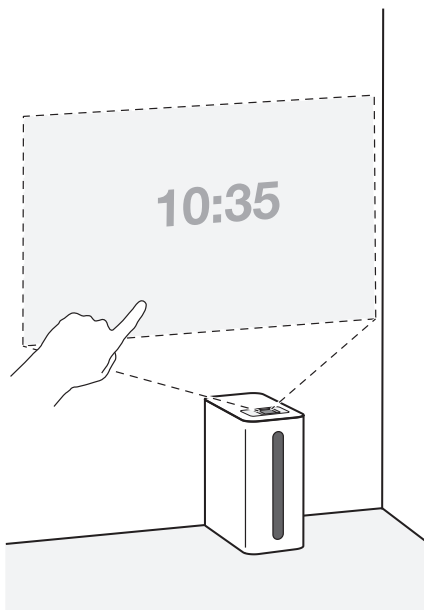

- 1 Place the device next to the wall in the correct orientation as shown in the illustration.
 - 2 To increase or decrease the projection area, reposition the device further from or closer to the wall.
- ! Touch functions are only available when the device is projecting onto a horizontal surface, or onto a vertical surface from a short distance.

Support for you

Access our support website directly on your device by visiting support.sonymobile.com, to find user guides, downloadable content, troubleshooting tips and contact information.

- ! Even if you don't have a network connection, you can access support contact information on your device. Depending on the country or region where you purchased your device, you can find this information directly in the Support application.

To access the Support application

- 1 From your **Home screen**, tap .

2 Find and tap .

-  Connect to the internet when using the Support application for the best available support.

Warranty and usage guidelines

For information about warranty and safety guidelines, please read the **Important information** provided under **Settings > About projector > Legal information** on your device.

To view the CE mark and the FCC ID

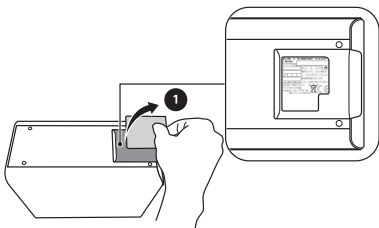

- Remove the slot cover as shown in the illustration.
- ! To see the full text of the EU declaration of conformity, visit: <http://www.compliance.sony.de/>.

To view the regulatory compliance mark

- Open the dialpad, then enter *#07#.

Legal information

Publication number: XXXX-XXXX.1

This Startup guide is published by Sony Mobile Communications Inc. or its local affiliated company, without any warranty. Improvements and changes to this Startup guide necessitated by typographical errors, inaccuracies of current information, or improvements to programs and/or equipment, may be made by Sony Mobile Communications Inc. at any time and without notice. Such changes will, however, be incorporated into new editions of this Startup guide. All illustrations are for illustration only and may not accurately depict the actual device.

See regulatory information such as the device CE mark in the relevant label tray in the device.

All product and company names mentioned herein are the trademarks or registered trademarks of their respective owners. Any rights not expressly granted herein are reserved. Visit www.sonymobile.com/global-en/legal/ for more information.

Manufacturer: Sony Mobile Communications Inc., 4-12-3 Higashi-Shinagawa, Shinagawa-ku, Tokyo, 140-0002 Japan. For EU product compliance: Sony Belgium, bijkantoor van Sony Europe Limited, Da Vincilaan 7-D1, 1935 Zaventem, Belgium.

© 2017 Sony Mobile Communications Inc. All rights reserved.

Supported frequency bands

Some frequency bands might be turned off in certain markets or by certain operators.

G1121

UMTS HSPA+ 800 (Band VI), 800 (Band XIX), 850 (Band V), 900 (Band VIII), 1700 (Band IV), 1900 (Band II),

2100 (Band I) MHz GSM GPRS/EDGE 850, 900, 1800, 1900 MHz LTE (Bands

1,2,3,4,5,7,8,12,17,19,20,26,28,38,39,40,41) WLAN, 2.4G/5G, NFC

SONY[®]

Startup guide

Xperia™ Projector
G1121

XPERIA

Sony Mobile Communications Inc.
4-12-3 Higashi-Shinagawa, Shinagawa-ku, Tokyo, 140-0002 Japan



XXXX-XXXX.1