

# GT47/GT48 Technical Description

The information contained in this document is the proprietary information of **Sony Ericsson Mobile Communications International**. The contents are confidential and any disclosure to persons other than the officers, employees, agents or subcontractors of the owner or licensee of this document, without the prior written consent of **Sony Ericsson Mobile Communications International**, is strictly prohibited. Further, no portion of this publication may be reproduced, stored in a retrieval system, or transmitted in any form or by any means, electronic or mechanical, including photocopying and recording, without the prior written consent of **Sony Ericsson Mobile Communications International**, the copyright holder.

### **First edition (June 2003)**

**Sony Ericsson Mobile Communications International** publishes this manual without making any warranty as to the content contained herein. Further **Sony Ericsson Mobile Communications International** reserves the right to make modifications, additions and deletions to this manual due to typographical errors, inaccurate information, or improvements to programs and/or equipment at any time and without notice. Such changes will, nevertheless be incorporated into new editions of this manual.

All rights reserved.

© **Sony Ericsson Mobile Communications International**, 2003

Publication number: LZT 123 7607 R1B

Printed in UK

---

# Contents

<b>1. Introduction</b> .....	<b>4</b>
1.1 Description .....	4
1.2 Highlights .....	4
1.3 Main Features and Services.....	5
1.4 Service and Support .....	9
1.5 Precautions .....	9
<b>2. Mechanical Description</b> .....	<b>10</b>
2.1 Overview .....	10
2.2 Physical Dimensions .....	11
<b>3. Electrical Description</b> .....	<b>12</b>
3.1 Power Supply and Extended I/O Connector .....	12
3.2 RS232 Serial and Extended I/O Interface .....	16
3.3 Audio Connector .....	22
3.4 Antenna Connector.....	24
3.5 SIM Card Reader .....	25
3.6 Real Time Clock .....	25
3.7 Software Updates .....	26
<b>4. Embedded Applications</b> .....	<b>27</b>
4.1 Features .....	27
4.2 Implementation .....	27
<b>5. TCP/IP Stack</b> .....	<b>29</b>
5.1 Implementation .....	29
<b>6. Operation</b> .....	<b>30</b>
6.1 Switching the GT47 On .....	30
6.2 Switching the GT47 Off.....	30
6.3 Operating States/LED .....	30
6.4 Power Save .....	31
6.5 Controller Mode .....	31
<b>7. Technical Data</b> .....	<b>32</b>
<b>8. AT Command Summary</b> .....	<b>36</b>
<b>9. Abbreviations and Definitions</b> .....	<b>42</b>

# 1. Introduction

## 1.1 Description

The GT47/GT48 is an intelligent GSM/GPRS control terminal that encapsulates everything you need for wireless M2M capability in one compact unit. In conjunction with Sony Ericsson's M2mpower package the GT47/48 can host and control your wireless application, minimising the need for extra components. Alternatively, it can be used as a powerful standalone GPRS modem with its intrinsic TCP/IP stack.

The GT47/48 is a self contained terminal with its own SIM card reader and standard connector interface, minimising the need for further hardware development. Its wide and useful range of IOs can be reconfigured to add functions and features that make your M2M solution both innovative and cost effective.

The GT47/GT48 can be used to provide a communications link for a variety of wireless applications including fleet and asset management, vending, security and alarm monitoring, e-maintenance and other telemetry applications. The ease of application development and hosting on the GT47/48 means M2M solutions in area of personal leisure (e.g. boats and caravans) and around the home can be addressed.

With dual band 900/1800 MHz (GT47) and 850/1900 MHz (GT48) versions available, your applications can be used all over the world.

The control terminal comes with a library of sample script applications to give developers a head start where needed.

The GT47/GT48 incorporates Sony Ericsson's GR47/GR48 GSM/GPRS engine.

*Note!* When the GT47 is referred to in the text the description covers the GT48 as well; unless specifically mentioned.

All functions described inside this Technical Description are only possible when the SIM-Card is inserted.

## 1.2 Highlights

- Intelligent, versatile GSM/GPRS control terminal
- Dual band, EGSM 900/1800MHz
- Customised applications can be embedded and run independently
- Self contained terminal with standard connectors
- 2 x RS232 interfaces with a useful range of configurable IOs
- TCP/IP stack
- Data: GPRS, HSCSD, CSD, SMS
- Voice: full rate, enhanced full rate, half rate

- SMS: mobile-originated, mobile-terminated, cell broadcast
- Fax: Group 3, Classes 1 & 2
- 15 way high density connector
- 5V - 32V d.c. input
- 4-wire audio connection
- Antenna connection (FME male)
- R&TTE type approved (GT47)

### 1.3 Main Features and Services

The GT47 performs a set of telecom services (TS) according to GSM standard phase 2+, ETSI and ITU-T. The services and functions of the GT47 are implemented by issuing customised applications embedded on the device, or by AT commands issued internally, or over the RS232 serial interface.

#### 1.3.1 Types of Mobile Station

The GT47 is a dual band control terminal with the GSM radio characteristics shown in the table below.

<i>GT47</i>	<i>E-GSM900</i>	<i>GSM1800</i>
Frequency Range (MHz)	TX: 880-915 RX: 925-960	TX: 1710-1785 RX: 1805-1880
Channel spacing	200kHz	200kHz
Number of channels	174 carriers *8 time slots E-GSM: channels 0 to 124 channels 975 to 1023	374 carriers *8 time slots DCS: channels 512 to 885
Modulation	GMSK	GMSK
TX phase accuracy	< 5° RMS phase error (burst)	< 5° RMS phase error (burst)
Duplex spacing	45MHz	95MHz
Receiver sensitivity at antenna connector	< -102dBm	< -102dBm
Transmitter output power at antenna connector	Class 4 2W (33dBm)	Class 1 1W (30dBm)
Automatic hand-over between EGSM 900 and GSM1800		

<i>GT48</i>	<i>GSM850</i>	<i>GSM1900</i>
Frequency Range (MHz)	TX: 824-849 RX: 869-894	TX: 1850-1910 RX: 1930-1990
Channel spacing	200kHz	200kHz
Number of channels	124 carriers *8 time slots GSM: channels 128 to 251	299 carriers *8 time slots PCS: channels 512 to 810
Modulation	GMSK	GMSK
TX Phase Accuracy	< 5° RMS phase error (burst)	< 5° RMS phase error (burst)
Duplex spacing	45MHz	80MHz
Receiver sensitivity at antenna connector	< -102dBm	< -102dBm
Transmitter output power at antenna connector	Class 4 2W (33dBm)	Class 1 1W (30dBm)
Automatic hand-over between GSM850 and GSM1900		

### 1.3.2 Short Message Service

The GT47 supports the following SMS services:

- Sending; MO (mobile-originated) with both PDU (protocol data unit) and text mode supported.
- Receiving; MT (mobile-terminated) with both PDU and text mode supported.
- CBM (cell broadcast message); a service in which a message is sent to all subscribers located in one or more specific cells in the GSM network (for example, traffic reports). This feature is network dependent.
- SMS STATUS REPORT according to GSM 03.40.
- SMS COMMAND according to GSM 03.40.

The maximum length of an SMS message is 160 characters when using 7-bit encoding. For 8-bit data, the maximum length is 140 characters. The GT47 supports up to 6 concatenated messages to extend this function.

### 1.3.3 Voice Services

The GT47 offers the capability of mobile originated and mobile terminated voice calls, as well as supporting emergency calls. Multi-party, call waiting and call divert features are available. Some of these features are network-operator specific.

For the inter-connection of audio, the GT47 offers a balanced 4-wire analogue interface.

DTMF (Dual Tone Multi Frequency) is supported.

The GT48 also supports the Adaptive Multi Rate (AMR) type of vocoder.

### 1.3.4 Data Services

The GT47 supports the following data protocols:

- ***GPRS (General Packet Radio Service).***

GT47 is a Class B terminals, which provide simultaneous activation and attachment of GPRS and GSM services. GT47 is a GPRS class 8 (4+1) enabled devices, which are capable of transmitting in one timeslot per frame (up link), and receiving at a maximum of four timeslots per frame (down link).

- ***CSD (Circuit Switched Data).***

GT47 is a capable of establishing a CSD communication at 9.6kbps.

- ***HSCSD (High Speed Circuit Switched Data).***

GT47 supports HSCSD class 2 (2+1) communication, with one timeslot per frame capacity in the up link and two timeslots per frame capacity in the down link.

### 1.3.5 Fax Services

The GT47 allows fax transmissions to be sent and received by commercial fax software installed on the application computer. Group 3 fax Classes 1 and 2 are supported.

### 1.3.6 Supplementary Services

- Call forwarding
- Call hold, waiting and multiparty
- Calling/called number identification
- Advice of charge
- USSD
- Alternate line service
- Customer service profile
- Preferred networks
- Operator selection
- Network registration
- Call barring
- Call transfer

### 1.3.7 Serial Communication

The GT47 enables an end-to-end communication path to be established between the telemetry/telematics application, either hosted internal or connected externally, and a remote terminal or host, via the GSM network.

Once a path has been set up, voice or data communication can take place. An RS232 9-signal serial interface is available via the GT47's 15-way high density data connector.

This primary serial interface can be used to:

1. Control the GT47 via an external PC or micro-controller using AT commands;
2. Send and receive data.

The GT47 supports the full set of AT commands according to GSM 07.05 and GSM 07.07. It also supports an extended set of Ericsson proprietary AT commands to add extra functionality.

AT commands are used to operate the GT47 with a broad range of functions including:

- configuring general parameters of the GT47
- setting up and controlling communications to and from the GSM network
- obtaining GSM network status information

Additionally the GT47 provides a second RS232 serial interface, operating as a 4-signal and GND interface, with hardware flow control (Rx, Tx, CTS and RTS). This 4-signal serial interface is controllable via embedded applications and may be used to control external accessories e.g. a GPS receiver.

For more detail on the AT commands supported by the GT47 see "AT Command Summary", page 36.

### 1.3.8 Extended I/O Interface

The control terminal contains several general purpose, configurable, input and output signals. Signals may be reconfigured by AT command or by intrinsic function when using embedded applications.

- 1 analogue input
- 3 digital inputs
- 5 digital outputs
- + 4.8V DC output

In addition, 6 of the control signals on the primary RS232 interface can be reconfigured for use as digital inputs or outputs if required.

The drivers controlling certain outputs have been designed to carry higher currents than normal logic IOs. They can be used to activate or power external devices, for example a switch or a relay.

A+4.8V output is available, if required, to power external devices.



### 1.3.9 Interfacing with the GT47

The GT47 uses the following industry standard connectors;

- 15 pin high density socket (RS232 serial port and extended I/O interface)
- RJ12 (plug-in power supply and extended I/O connector)
- RJ9 (handset audio connector)
- Integral SIM card reader
- FME male (antenna connector)

## 1.4 Service and Support

To contact customer support please use the details below:

Customer Support  
Sony Ericsson Mobile Communications  
Maplewood Building  
Chineham Business Park  
Basingstoke  
RG24 8YB

E-mail: [modules.support@sonyericsson.com](mailto:modules.support@sonyericsson.com)

or

[modules.info@sonyericsson.com](mailto:modules.info@sonyericsson.com)

Information about Sony Ericsson and its products is available on the following web site:

<http://www.SonyEricsson.com/M2M>

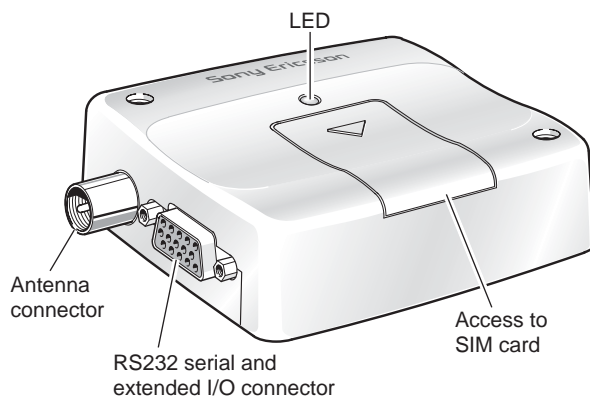
## 1.5 Precautions

The GT47 as a standalone item is designed for indoor use only. To use outdoors it must be integrated into a weatherproof enclosure. Do not exceed the environmental and electrical limits as specified in “Technical Data”, page 32.

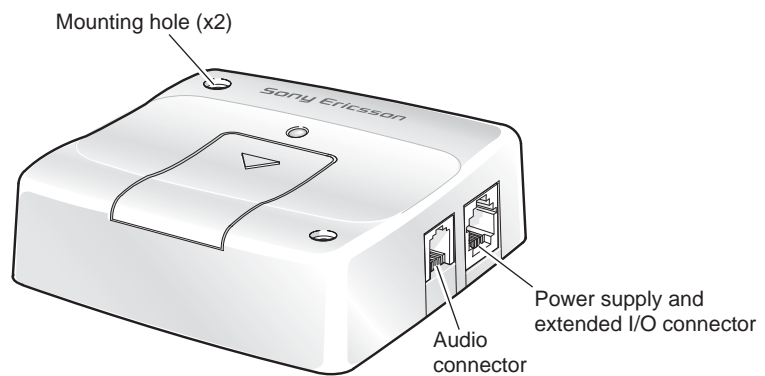
## 2. Mechanical Description

### 2.1 Overview

The pictures below show the mechanical design of the module along with the positions of the different connectors and mounting holes. The module case is made of durable PC/ABS plastic.

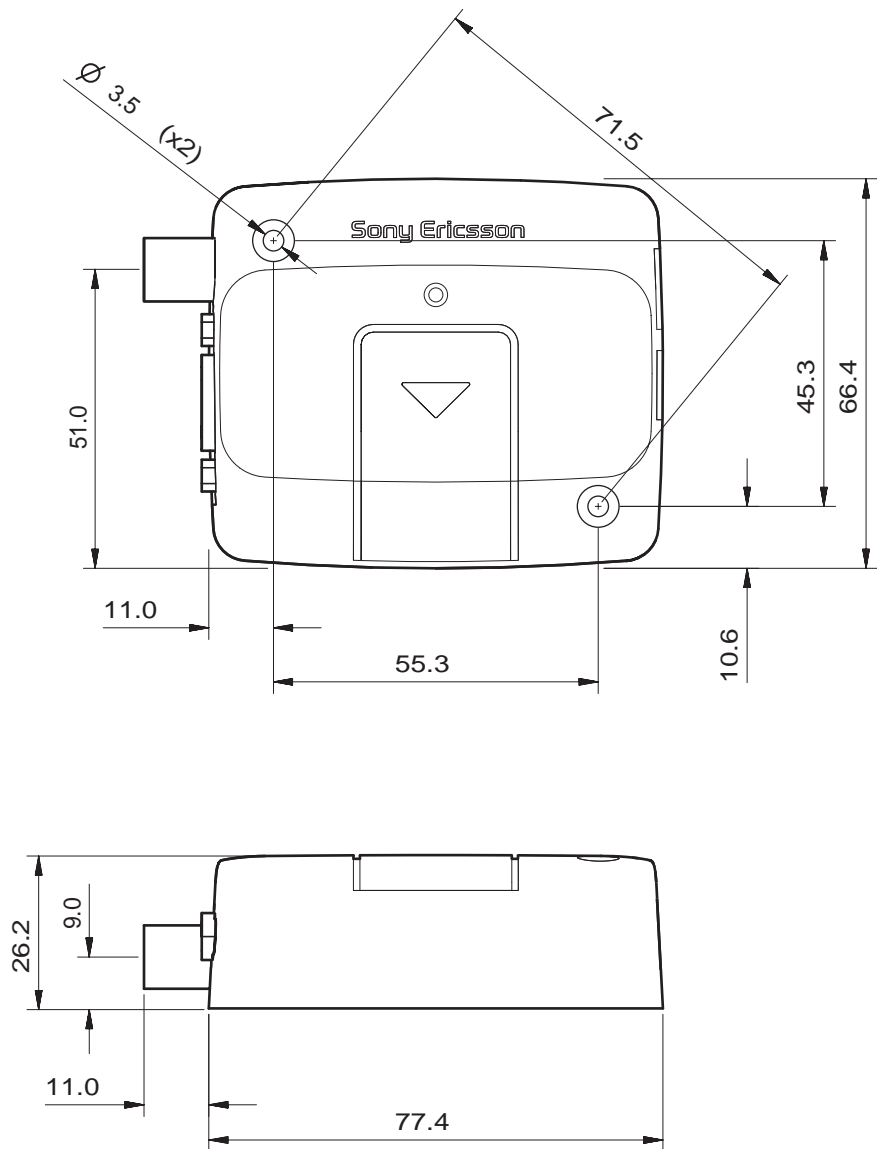


*Figure 2.1 Module viewed from the left side*



*Figure 2.2 Module viewed from the right side*

## 2.2 Physical Dimensions



Measurements are given in millimetres. See also "Technical Data", page 32.

## 3. Electrical Description

All electrical connections to the module are protected in compliance with the standard air (8kV) and contact (4kV) Electrostatic Discharge (ESD) tests, of EN 61000-4-2.

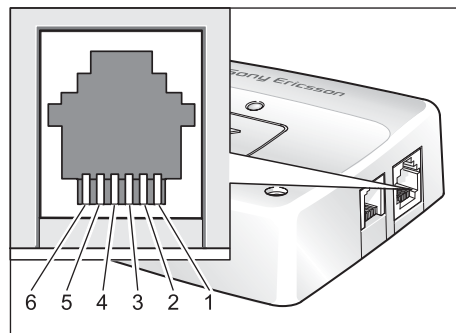
The module uses the following industry standard connectors:

- High density 15 pin (RS232 serial and extended I/O interface)
- RJ12 6-way (power supply and extended I/O connector)
- RJ9 4-way (handset connector)
- SIM card reader
- FME male coaxial jack (antenna connector)

### 3.1 Power Supply and Extended I/O Connector

An RJ12 6-way connector, as shown and described below, serves as a means of supplying and controlling d.c. power to the modem. Additionally there are several extended input/output signals available that can be used to control or interface external systems and devices.

General signal description:



- 1 V<sub>IN</sub>
- 2 OUT-2
- 3 IN-1
- 4 TO\_IN
- 5 OUT-1
- 6 GND

The power connector electrical characteristics are listed below:

<i>Pin</i>	<i>Signal</i>	<i>Dir</i>	<i>Limits</i>	<i>Description</i>
1	V <sub>IN</sub>	I	5 - 32V	Positive power input
2	OUT-2	O	32V, 0.25A	Low side switch, short circuit protected
3	IN-1	I	-0.5 - 32V	Digital Input V <sub>IH</sub> > 3V, V <sub>IL</sub> < 2.8V Internal Pull Down of 40KΩ
4	TO_IN	I	-0.5 - 32V	Active low control line used to switch the GT47 off/on. V <sub>IH</sub> > 5V, V <sub>IL</sub> < 2V Power off/on: t > 0.2s Internal Pull Up to V <sub>IN</sub> of 20KΩ
5	OUT-1	O	V <sub>IN</sub> , 0.4A	High side switch, short circuit protected
6	GND	I	-	Negative power (ground) input and return path for TO_IN and the extended inputs and outputs

**Note!** Signal OUT-2 on the RJ12 connector is switched in parallel to signal OUT-4 on the 15-pin high density socket. The individual output signals are generated by two different low side switches inside the module driven from a common control signal.

### 3.1.1 Power Supply Interface

The supply voltage V<sub>IN</sub>, required by the GT47, is in the range 5V - 32V d.c. V<sub>IN</sub> and GND are reverse polarity and over voltage protected.

The GT47 switches on automatically once the 5V-32V dc supply voltage is applied.

**Note!** The GT47 will not switch on if TO\_IN is shorted to ground when the dc supply is applied.

**Note!** For more information on switching the GT47 on and off please see section “6. Operation”, page 30.

**Note!** Please be aware that the total current carried via either the V<sub>IN</sub> or GND pins will be the sum of the intrinsic power consumption of the GT47 and any drive current supplied via OUT-1 or OUT-2 (or other IOs). The current on either of the V<sub>IN</sub> or GND pins must not exceed 1.5A.

**Caution!** It is recommended that the system integrator provides appropriate fusing otherwise the GT47 may be damaged.

*Current Consumption at Standard Operation*

Supply Voltage	5V		12V		32V		
<i>Power Down Mode:</i>							
	AV	Max	AV	Max	AV	Max	
	5	15	5	15	20	50	mA
<i>Standby Mode (typical):</i>							
Frequency	AV	Max	AV	Max	AV	Max	
850/900 MHz	26	110	9	43	6	20	mA
1900/1800 MHz	26	120	9	45	6	19	mA
<i>Talk Mode (typical):</i>							
Frequency	AV	Max	AV	Max	AV	Max	
850/900 MHz	220	1230	90	520	40	200	mA
1900/1800 MHz	170	960	70	350	30	140	mA

**Notes!** **Power Down Mode:** DC power is applied but the GT47 is switched OFF.

**Standby Mode:** The module is switched ON and camped on to the network. No call in progress.

**Talk Mode:** The module is switched ON and a voice/data call is in progress.

The power consumption during transmission in Talk Mode is measured at maximum transmitted power.

The power consumption in Standby Mode is measured at the maximum paging rate (Paging Rate 2).

*Current Consumption with external +4.8V Supply Active*

For the following calculations it was assumed that the external +4.8V load is 70mA.

Supply Voltage	5V		12V		32V		
<i>Power Down Mode:</i>							
	AV	Max	AV	Max	AV	Max	
	5	15	5	15	20	50	mA
<i>Standby Mode (typical):</i>							
Frequency	AV	Max	AV	Max	AV	Max	
850/900 MHz	112	196	45	79	19	33	mA
1900/1800 MHz	112	206	45	81	19	32	mA
<i>Talk Mode (typical):</i>							
Frequency	AV	Max	AV	Max	AV	Max	
850/900 MHz	306	1316	126	556	53	213	mA
1900/1800 MHz	256	1046	106	386	43	153	mA

**Note!** These tables do not include the power consumption associated with any drive current supplied via further GT47 outputs, e.g. OUT-1 or OUT-2.

### 3.1.2 Extended I/O Signals

#### *Digital Inputs*

The digital input IN-1 is available on pin 3 of the RJ12 connector. Its state is detected by IO5 of the embedded GR47 engine, see GT47-GR47 signal cross reference table, page 21.

The distinction between low level and high level signals is at the voltage level of 3 V. Voltages above 3 V are detected as high level voltages and voltages below 2.8 V are detected as low level.

#### *Digital Outputs*

The RJ12 power supply connector has two different output drivers:

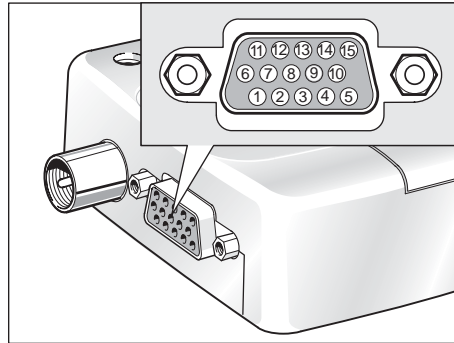
- OUT-1 is driven by a high side switch that applies  $V_{IN}$  to pin 5 of the RJ12 connector. IO1 of the embedded GR47 engine is used to activate the OUT-1 signal, see GT47-GR47 signal cross reference table, page 21.
- OUT-2 is driven by a low side switch that shorts pin 2 of the RJ12 connector to ground when activated. IO3 of the embedded GR47 engine is used to activate OUT-2, see GT47-GR47 signal cross reference table, page 21.

#### *$V_{IN}$ Monitoring*

The voltage,  $V_{IN}$ , can be monitored internally by the GT47, for example if the control terminal is supplied from an external battery. ADC1 on the GR47 is used for this purpose, see GT47-GR47 signal cross reference table, and is calibrated to operate in the voltage range 0 – 31.875 V. The resolution of the 8 bit converter, ADC1, provides a measurement accuracy of approximately 3%.

### 3.2 RS232 Serial and Extended I/O Interface

The GT47 supports a standard 9 signal RS232 serial interface (EIA/TIA 574) on the 15 pin high density connector together with a range of configurable I/Os including a second 4-wire RS232 interface.



1 DCD	4 IN-3	7 RTS	10 RI	13 DTR
2 RD	5 OUT-3	8 CTS	11 IN-2	14 GND
3 TD	6 DSR	9 4.8V	12 OUT-4	15 ANA_IN

Signals that support an alternative configuration can be reconfigured using the appropriate AT command (e.g. AT+E2IO) or via an intrinsic function if using an embedded application.

**Note!** When reconfiguring a GT47 signal, via AT command or intrinsic function, the corresponding GR47 signal name must be used, see GT47-GR47 signal cross reference table, page 21.

The electrical characteristics of the serial port signals are shown below:

Pin	GT47 Signal	Dir	Max. Voltage limits	Description
1	DCD	O	±13.2V	RS232 signal Data carrier detect $V_{out} \geq \pm 5V$
2	RD	O	±13.2V	RS232 signal: Received data $V_{out} \geq \pm 5V$
3	TD	I	± 25V	RS232 signal: Transmitted data $V_{IL} < 0.6V, V_{IH} > 2.4V$
4	IN-3	I	-0.5 - 32V	Digital input $V_{IH} > 3V, V_{IL} < 2.8V$ PullDown with 40KΩ
5	OUT-3	O	32V, 0.25A	low side switch, short circuit protected
6	DSR	O	±13.2V	RS232 signal: Data set ready $V_{out} \geq \pm 5V$
7	RTS	I	±25V	RS232 signal: Request to send $V_{IL} < 0.6V, V_{IH} > 2.4V$
8	CTS	O	±13.2V	RS232 signal: Clear to send $V_{out} \geq \pm 5V$



<i>Pin</i>	<i>GT47 Signal</i>	<i>Dir</i>	<i>Max. Voltage limits</i>	<i>Description</i>
9	4.8V	O	0 - +4.8V, 75mA	Voltage supply for external devices Supply voltage +4.8V, max. current 75mA
10	RI	O	±13.2V	RS232 signal: Ring indicator $V_{out} \geq \pm 5V$
11	IN-2	I	-0.5 - 32V	Digital input $V_{IH} > 3V$ , $V_{IL} < 2.8V$ PullDown with 40KΩ
12	OUT-4	O	32V, 0.25A	low side switch, short circuit protected
13	DTR	I	±25V	RS232 signal: Data Terminal Ready $V_{IL} < 0.6V$ , $V_{IH} > 2.4V$
14	GND	I	-	Ground connection and return path for the extended inputs/outputs
15	ANA_IN	I	-0.5 - 32V	Analog input measurement range: 0 - 12.75V

### 3.2.1 Standard RS232 Serial interface and Signals

The module supports a standard RS232 serial interface (EIA/TIA 574) via its 15 pin high density connector, shown above.

### 3.2.2 Serial Data

The GT47 supports the standard data character format of 1 start bit, 8 bit data, no parity plus 1 stop bit, in total 10 bits per character. In line with serial communication terminology the module is the data circuit-terminating equipment (DCE) and the external application or computer is the data terminating equipment (DTE).

### 3.2.3 Serial Data Signals - RD, TD

The default baud rate is 9.6kbps, however higher bit rates up to 230.4kbps are supported and can be set by AT commands. At start-up the module transmits and receives data at the default rate of 9.6kbps in either standard AT mode or binary mode (the first received data - AT or binary format - determines the operating mode).

*Serial Data From GT47 (RD)*

*Pin 2*

RD is an output signal that the GT47 uses to send data to the external application.

*Serial Data To GT47 (TD)*

*Pin 3*

TD is an input signal, used by the external application to send data to the GT47.

### 3.2.4 Control Signals - RTS, CTS, DTR, DSR, DCD, RI

RTS and CTS are capable of transmitting at 1/10th of the data transmission speed for data rates up to 230.4kbps (byte-oriented flow control mechanism).

#### *Request to Send (RTS)* *Pin 7*

Used to condition the GT47 for data transmission. The default level is inactive by internal pull down.

The exact behaviour of RTS is defined by an AT command. Software or hardware control can be selected. Hardware flow is the default control.

The application must pull RTS high to enable transmission from the GT47.

#### *Clear To Send (CTS)* *Pin 8*

CTS indicates that the GT47 is ready to transmit data. The default level is high. You can define the exact behaviour of CTS through an AT command, and can select software or hardware flow control.

#### *Data Terminal Ready (DTR)* *Pin 13*

DTR indicates that the DTE is ready to send and receive data. It also acts as a hardware 'hang-up', terminating calls when switched low. The signal is active high. You can define the exact behaviour of DTR with an AT command.

#### *Data Set Ready (DSR)* *Pin 6*

An active DSR signal is sent from the GT47 to the application (DTE) to confirm that a communications path has been established. DSR has two modes of operation, use the AT command AT&S to set the mode.

#### *Data Carrier Detect (DCD)* *Pin 1*

DCD indicates that the GT47 is receiving a valid carrier (data signal) when high. You can define the exact behaviour of DCD with an AT command.

#### *Ring Indicator (RI)* *Pin 10*

RI indicates that a ringing signal is being received by the GT47 when high. You can define the exact behaviour or RI with an AT command.

### Alternative Configuration

It is possible to reconfigure one or more of the signals in this section (RTS, CTS, DTR, DSR DCD and RI) to be used as digital inputs or outputs if the full RS232 serial interface is not required. Configuration is achieved using AT command (AT+E2IO) or via embedded application intrinsic functions, please refer to GT47-GR47 signal cross reference table, page 21.

To be reconfigured as a digital IO, each signal must retain the direction and the logic voltage levels attributed to it when used as an RS232 signal. For example DSR can only be reconfigured as a digital output with  $V_{out} \geq \pm 5V$ .

### 3.2.5 Extended I/O Signals

Please refer to GT47-GR47 signal cross reference table, page 21, for more information on the relationship between signal names and pin numbers of the GT47 and the embedded GR47 engine.

#### Digital Inputs

Pin 4 & 11

Digital inputs IN-2 and IN-3 are available on the HD15 connector via pins 11 and 4 respectively. The inputs are detected via signals IO4 and IO7 of the embedded GR47 engine.

*Note!* As an alternative configuration signals IN-2 and IN-3 can be used to support a second RS232 serial interface as RTS-2 and TD-2. Further information is given below.

#### Analog Input

Pin 15

The signal ANA\_IN can be used for measuring analog input values in the range 0 -12.75V. ADC2 of the embedded GR47 is used to detect ANA\_IN.

The resolution of the converter is 8 bit with an measurement accuracy of about 3%.

The input impedance of the ANA\_IN pin is 50 K $\Omega$ .

#### Digital Outputs

Pin 5 & 12

Digital outputs OUT-3 and OUT-4 are available on the HD15 connector via pins 5 and 12 respectively. The outputs are controlled via signals IO8 and IO3 of the embedded GR47 engine.

Signal OUT-4 on the HD15 connector is switched in parallel to signal OUT-2 on the RJ12 connector. The individual output signals are generated by two different low side switches inside the terminal driven from the common control signal, IO3. All GT47 output signals driven by

low side switches return to open circuit when deactivated. This allows the external application hardware to determine the desired logic voltage levels with the appropriate pull-up.

The output drivers are low side switches which short the pin to GND if they are activated.

*Note!* As an alternative configuration signals OUT-3 and OUT-4 can be used to support a second RS232 serial interface as CTS-2 and RD-2. Further information is given below.

#### +4.8V Output Supply

Pin 9

There is a voltage regulator implemented inside the module that is capable of supplying an external voltage source of +4.8V with a maximum current of 75 mA.

The voltage source can be switched on/off with the DAC signal of the internal GR47 GSM engine.

By default the voltage source is switched on. A high level of 2.75V at the DAC output of the GR47 GSM engine will switch the voltage source off.

*Note!* The +4.8V source may be switched on/off via an embedded or external application and so may be used as an optional digital output with levels of +4.8V and open circuit.

### 3.2.6 Second RS232 Serial Interface

IN-3 and OUT-3 can be automatically reconfigured as signals TD-2 and RD-2, of a second serial interface, by enabling UART3 of the internal GR47. UART 3 may be enabled using AT command or intrinsic function.

In addition, IN-2 and OUT-4 can be automatically reconfigured as signals CTS-2 and RTS-2 of the second serial interface by enabling hardware flow control for UART3 on the internal GR47. Hardware flow control can be enabled using intrinsic function only.

*Note!* The signal level thresholds for each of the digital inputs of the second serial interface are:  $3V < V_{IH} < 3.2V$  and  $V_{IL} < 2.8V$ .

An external RS232 transceiver component may be used to convert the serial interface to standard RS232 electrical levels. The GT47's +4.8 V output can be used to provide power for the transceiver.

### 3.2.7 Relationship between GT47 and GR47 signals

When reconfiguring a GT47 signal, via AT command or intrinsic function, the corresponding GR47 signal name must be used, see the GT47-GR47 signal cross reference tables overleaf.

GT47 - GR47 Signal Cross-reference Table A

GT47 / GT48			Relationship to the GR47/GR48 engine	
GT47 Pin	GT47 Primary Signal	Dir.	GR47 Pin	Corresponding GR47 Signal
<i>HD15 Connector</i>				
1	DCD	O	38	DCD
2	RD	I	42	RD
3	TD	O	41	TD
4	IN-3	I	43	IO7
5	OUT-3	O	44	IO8
6	DSR	O	32	DSR
7	RTS	I	39	RTS
8	CTS	O	40	CTS
9	+4.8V	O	20	DAC
10	RI	O	36	RI
11	IN-2	I	24	IO4
12	OUT-4	O	23	IO3 <sup>†</sup>
13	DTR	I	37	DTR
14	GND			
15	ANA_IN	I	27	ADC2
<i>RJ12 Connector</i>				
1	V <sub>IN</sub>			
2	OUT-2	O	23	IO3 <sup>†</sup>
3	IN-1	I	13	IO5
4	TO_IN			
5	OUT-1	O	21	IO1
6	GND			
<i>GT47 Internal Function</i>				
	V <sub>IN</sub> Monitoring	I	26	ADC1
	Power Save Mode	O	22	IO2

<sup>†</sup> IO3 on the embedded GR47 provides the common control signal for both GT47 signals OUT-2 and OUT-4.

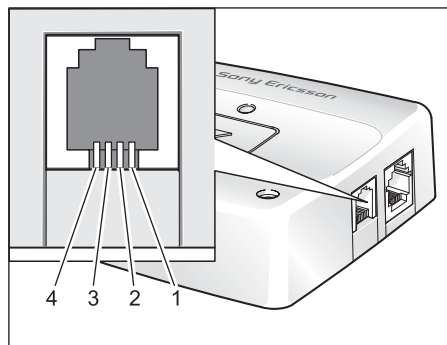
GT47-GR47 Signal Cross-reference Table B

GT47 / GT48			Relationship to GR47/GR48 engine	
GT47 Pin	GT Alternative signal	Dir.	Pin	Corresponding GR47 Signal
<i>HD15 Connector</i>				
1	OUT-6	O	38	O1
2		I	42	
3		O	41	
4	TD-2	I	43	TD3
5	RD-2	O	44	RD3
6	OUT-7	O	32	O3
7	IN-4	I	39	IO9
8	OUT-8	O	40	O4
9	OUT-5	O	20	DAC
10	OUT-9	O	36	O2
11	RTS-2	I	24	IO4
12	CTS-2	O	23	IO3
13	IN-5	I	37	IN1
14				
15				

### 3.3 Audio Connector

A 4-way RJ9 connector, as shown below, allows a telephone handset to be plugged into the GT47, giving access to the microphone and earpiece signals. The connector may also be used to drive other analogue audio sub-systems or devices.

The module is configured to work with a range of handsets. If necessary, changes can be made to the characteristics of the audio interface by sending the GT47 appropriate AT commands.



- 1 MICN      3 BEARP
- 2 BEARN    4 MICP

### 3. ELECTRICAL DESCRIPTION

Audio signal descriptions are listed below:

<i>Pin</i>	<i>Signal</i>	<i>Dir</i>	<i>Description</i>
1	MICN	I	Microphone negative input
2	BEARN	O	Earpiece negative output
3	BEARP	O	Earpiece positive output
4	MICP	I	Microphone positive input

MICP and MICN are balanced differential microphone input signals. These inputs are compatible with an electret microphone.

BEARP and BEARN are the speaker output signals. These are differential-mode outputs. The electrical characteristics are given in the table below.

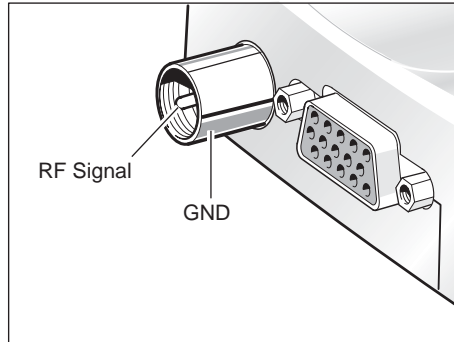
<i>Parameter</i>	<i>Limit</i>
Output level (differential)	$\geq 4.0V_{pp}$
Output level (dynamic load = $32\Omega$ )	$\geq 2.8V_{pp}$
Distortion at 1 kHz and maximum output level	$\leq 5\%$
Offset, BEARP to BEARN	$\pm 30mV$
Ear piece mute switch attenuation	$\geq 40dB$

The following table shows the ear piece impedances that can be connected to BEARP and BEARN.

<i>Ear piece model</i>	<i>Impedance</i>	<i>Tolerance</i>
Dynamic ear piece	$[32\Omega + 800\mu H] // 100pF$	$\pm 20\%$
Dynamic ear piece	$[150\Omega + 800\mu H] // 100pF$	$\pm 20\%$
Piezo ear piece	$1k\Omega + 60nF$	$\pm 20\%$

### 3.4 Antenna Connector

The antenna connector allows transmission of radio frequency (RF) signals between the GT47 and an external customer-supplied antenna. The module is fitted with a 50 $\Omega$ , FME male coaxial jack as shown below.



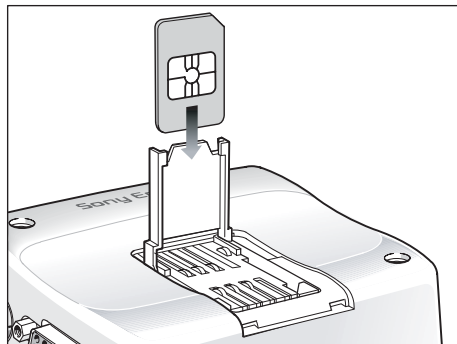
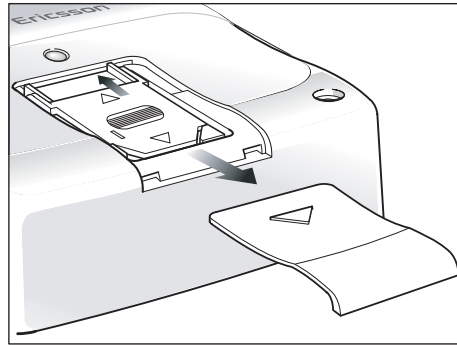
The table below shows the antenna electrical characteristics:

<i>Parameter</i>	<i>Limit</i>	<i>Description</i>
Nominal impedance	50 $\Omega$ (SWR better than 2.5:1)	
Output Power	2 Watt peak (Class 4)	EGSM 850/900
	1 Watt peak (Class 1)	GSM1800/1900
Static Sensitivity	Better than -102 dBm	EGSM 850/900
	Better than -102 dBm	GSM1800/1900



### 3.5 SIM Card Reader

The module is fitted with a SIM card reader designed for 3 V and 5 V SIM cards. It is the flip-up type which is lockable in the horizontal position and is accessed through a removable panel as shown below.



The SIM card reader incorporates a SIM presence switch which detects whether a SIM card is inserted. The full operation of the GT47 relies on a SIM card being inserted.

*Caution!* Some GT47 functionality may be lost if you try to operate the control terminal without a SIM card.

The SIM presence switch also ensures that when a SIM card is inserted or removed the unit is reset, as long as the GT47 is switched ON.

### 3.6 Real Time Clock

The module contains a real time clock (RTC) to maintain accurate timekeeping and to enable “timestamping” of messages.

The RTC is powered all the time that the GT47 is turned on. When the GT47 is powered off, a storage energy device within the module provides back-up power to maintain the RTC for several hours - please contact Sony Ericsson Customer Support for more information.

### *3.7 Software Updates*

It is possible, and sometimes necessary, to update the module software. Updates must be carried out by a Sony Ericsson approved technician. Please contact your supplier for details (see “Service and Support”, page 9).

## 4. Embedded Applications

The module has the capability to store and run customer written code in the form of a script during the processors idle time, through the use of an on board interpreter.

### 4.1 Features

Main features of embedded applications are as follows.

- C based scripting language (Sony Ericsson specific)
- Over the air upgrade of scripts (NOT GSM software)
- Library of intrinsic functions
- Multiple on radio device script support

### 4.2 Implementation

The module has up to 44kbytes of space available for storage of two scripts in the scripting language and 25kbytes of operating RAM. Structures included in this language are:

- If - then - else statements
- While loops
- For loops

All hardware interfaces that are normally available to the module through the AT commands are available to the embedded application. Further drivers have been written such as M bus and I<sup>2</sup>C for use by the embedded application (EA) through the use of the I/O pins.

#### 4.2.1 Limitations

Since the module is processing the script using its own memory, limitations are placed onto the scripts that are run.

- A direct comparison cannot be made to a fully compiled C program in terms of size but a gauge of script size is that if each line were 128 characters long in the script then the script could be 350 lines long.
- Processing power is something that needs to be considered as the script is run as a low priority process within the software. However, controller mode stops GSM operation and provides all the processing power for the script to be run. See the Application Guide for more details.
- Code cannot be ported directly from an existing application and loaded directly onto the radio device. It must be re written in the Sony Ericsson Mobile script language so that the radio device interpreter can function correctly.

#### 4.2.2 M2mpower IDE (Integrated Developers Environment)

The IDE is a windows based package which allows the user to write, simulate, debug and download the application into a radio device with the embedded application (EA) software. The standard version is designed to run on Windows XP and 2000, other versions are available for 98 if required.

A guide is available for implementing applications using the developers kit and the embedded application (EA) functionality.

This is a required package to be able to implement an embedded application (EA).

For further information please contact SEM customer support.

## 5. TCP/IP Stack

An on board IP/TCP/UDP stack has been integrated into the software negating the need for the customer to implement one in their own code base.

For early software releases this is only accessible through the embedded applications (see previous section) using intrinsic functions.

### *5.1 Implementation*

The following types of commands allow various functions:

- Open/closing IP connection - Negotiates/closes a dynamic IP address with the web server.
- Send/Receive TCP packets - Performs all TCP operations to send and receive packets.
- Send/Receive UDP packets - Performs all UDP operations to send and receive packets.
- Resolve URL to an IP address - Similar to nslookup command in DOS

When the unit is set up and controlled using the embedded applications either the embedded applications or an external application can generate data to be sent and pass it to the radio device for transmission.

This effectively provides a transparent communication link to an internet server from the application over GPRS.

## 6. Operation

### 6.1 Switching the GT47 On

The GT47 is turned ON automatically once DC power is applied. If the GT47 is turned OFF, using one of the methods described in 6.2, the control terminal can be turned ON again through one of two methods:

- pull signal TO\_IN to ground for  $t > 0.2s$ , then release.
- activate the main RS232 control line DTR, low to high for  $> 0.2s$

The GT47 is fully operational after 4 seconds. Logging onto a network may take longer than this and is outside the control of the GT47.

*Note!* The GT47 will not switch on if TO\_IN is shorted to ground when the dc supply is applied.

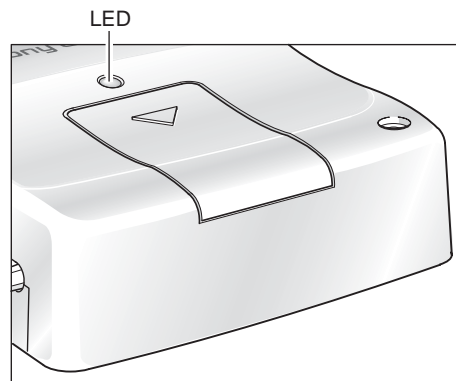
### 6.2 Switching the GT47 Off

There are two ways to switch off the GT47 as described below.

- Use the appropriate AT command (AT+CFUN);
- pull signal TO\_IN to ground for  $t > 0.2s$ , then release.

### 6.3 Operating States/LED

The GT47 has a green LED, as depicted below, which is used to indicate various operating states. These states are described in following table.



<i>Operating state</i>	<i>LED</i>
After switching on the GT47	On after 4s
GT47 switched off or power removed from the module	Off
Standby or talk	Flashing
No network, network search, no SIM card, no PIN entered	On

## 6.4 Power Save

The GT47 can power down the main RS232 IC when not needed in order to minimise power consumption. The IC is powered up automatically at start-up but can be powered down by setting the output of IO2 on the embedded GR47 (pin22) to low via AT command or embedded application. Once powered down, the IC can be woken up by setting the output of IO2 high on the GR47 via AT Command.

Even when powered down the IC is able to pass a DTR signal received on the serial interface. Therefore an embedded application that monitors DTR, while the IC is powered down, can be made to wake up the IC, if a signal is received, by setting IO2 on the GR47 high.

## 6.5 Controller Mode

The GT47, when powered up, will normally start up its GSM signalling software and look to register on the GSM network. Any embedded application script runs as a background process as and when the GSM software is idle. As a feature available via embedded applications the GT47 can be placed in 'controller mode' whereby the GT47 powers up with a minimal subset of radio functionality. The GSM signalling software is halted and the embedded applications script has full control of the processor.

Controller mode allows an application to run with more predictable response times.

## 7. Technical Data

### Data Features

CSD	Up to 9.6kbps, transparent and non-transparent
HSCSD (2+1)	Up to 28.8kbps
GPRS Class B (4+1) - P channels - Coding schemes CS1 - CS4	85.6kbps (subject to network support and terminal location)
GSM	07.10 multiplexing protocol

### Short Message Service Features

SMS	Text and PDU
	Point to point (MT/MO)
	Cell broadcast
	concatenation of up to 6 SMS

### Voice Features

	Full Rate, Enhanced Full Rate and Half Rate (FR/EFR/HR)
	Echo Cancellation and Noise Reduction
	Dual Tone Multi Frequency (DTMF)

### Fax Features

	Group 3
	Class 1 and 2



*Data Storage*

SMS storage capacity	40 in the module In addition, the unit can handle as many SMS as the SIM can store
Phone book capacity	100

*Power Supply*

Supply voltage range	5 - 32V d.c.
----------------------	--------------

*Radio Specifications*

Frequency range	GT47: EGSM 900MHz and 1800MHz (dual band)
Maximum RF output power	2W (900MHz) and 1W (1800MHz)
Antenna impedance	50 $\Omega$
Static sensitivity	Better than -102dBm

*Audio Specifications*

<i>Parameter</i>	<i>Limit</i>
Output level (differential)	$\geq 4.0V_{pp}$
Output level (dynamic load = 32 $\Omega$ )	$\geq 2.8V_{pp}$
Distortion at 1kHz and maximum output level	$\leq 5\%$
Offset, BEARP to BEARN	$\pm 30mV$
Ear-piece mute-switch attenuation	$\geq 40dB$

<i>Ear piece model</i>	<i>Impedance</i>	<i>Tolerance</i>
Dynamic ear piece	[32 $\Omega$ + 800 $\mu$ H] // 100pF	$\pm 20\%$
Dynamic ear piece	[150 $\Omega$ + 800 $\mu$ H] // 100pF	$\pm 20\%$
Piezo ear piece	1k $\Omega$ + 60nF	$\pm 20\%$

*SIM Card Reader*

Voltage type	Support for 3 V and 5 V SIM cards
--------------	-----------------------------------

*Electrical Connectors and LED*

Plug-in power supply connector and extended I/O	RJ12 6-way
Handset audio connector	RJ9 4-way
Antenna connector	FME male
RS232 port	high density socket, 15 pin
LED	Green

*Mechanical Specification*

Length	77.4mm
Width	66.4mm
Height	26.2mm
Weight	<110g

*Environmental specifications*

Operating temperature range	-30°C to +75°C
Storage temperature range	-40°C to +85°C
Relative humidity	5 - 95%, non-condensing
Stationary vibration, sinusoidal	Displacement: 7.5mm Acceleration amplitude: 20m/s <sup>2</sup> and 40m/s <sup>2</sup> Frequency range: 2-8Hz, 8-200Hz, 200-500Hz
Stationary vibration, random	Acceleration spectral density (m <sup>2</sup> /s <sup>2</sup> ): 0.96, 2.88, 0.96 Frequency range: 5-10Hz, 10-200Hz, 200-500Hz, 60 min/axis
Non-stationary vibration, including shock	Shock response spectrum I, peak acceleration: 3 shocks in each axis and direction; 300m/s <sup>2</sup> , 11 ms Shock response spectrum II, peak acceleration: 3 shocks in each axis and direction; 1000m/s <sup>2</sup> , 6ms
Bump	Acceleration: 250m/s <sup>2</sup>
Free fall transportation	1.2m
Rolling pitching transportation	Angle: ±35degrees; period: 8s
Static load	10kPa
Low air pressure/high air pressure	70kPa/106kPa

*Certification*

Directive 1999/5/EC	EMC: EN 301 489-1
	EMC: EN 301 489-7
	Safety: EN 60950-1
	GSM 3GPP TS 51.010-1
Tested according to GCF-CC	

## 8. AT Command Summary

The AT standard is a line-oriented command language. AT is an abbreviation of ATtention and it is always used to start sending a command line from the terminal equipment (TE) to the terminal adaptor (TA).

The command line consists of a string of alphanumeric characters. It is sent to the GT47 to instruct it to perform the commands specified by the characters.

As the list of AT commands supported occasionally changes, it is wise to check the latest listing with Sony Ericsson before starting any software development (see “Service and Support”, page 9).

The AT commands listed below are supported by the GR47/48 (*italic*) within the GT47. Be aware that not all AT commands will perform valid operations in the GT47 owing to its modified range of IOs.

<i>AT Command</i>	<i>Description</i>
AT	Attention Command
AT&C	Circuit 109 (DCD) Control
AT&D	Circuit 108 (DTR) Response
AT&F	Set to Factory Defined Configuration
AT&S	Circuit 107 (DSR) response
AT&W	Store User Profile
AT*	List all Supported AT Commands
AT*E2APC	Application Program Control
AT*E2APD	Application Program Download
AT*E2APR	M2M Audio Profile Manipulation
AT*E2CD	Ericsson M2M Cell Description
AT*E2EAMS	Ericsson M2M Audio Profile Modification
AT*E2EMM	Ericsson M2M Engineering Monitoring Mode
AT*E2ESC	M2M Escape Sequence Guard Time
AT*E2FAX	Ericsson M2M Fax Comm. Baud Rate Modification
AT*E2IO	Ericsson M2M Input/Output Read/Write
AT*E2OTR	Operational Temperature Reporting
AT*E2NBTS	Ericsson M2M Neighbour BTS
AT*E2NMPR	Ericsson M2M Set NMEA (GPS) Port Rate
AT*E2PBCS	Ericsson M2M Phonebook Check Sum
AT*E2PHFB	Portable Handsfree Button Sense Enable

## 8. AT COMMAND SUMMARY

---

<i>AT Command</i>	<i>Description</i>
AT*E2SMSRI	Ring Indicator for SMS
AT*E2SPI	Serial Peripheral Interface
AT*E2SPN	M2M Service Provider Indication
AT*E2SSD	M2M Supplementary Service Dispatch
AT*E2SSI	M2M Supplementary Service Indications
AT*E2SSN	Ericsson M2M SIM Serial Number
AT*E2STKC	M2M STK Set Up Call
AT*E2STKD	M2M STK Display Text
AT*E2STKG	M2M STK Get Inkey
AT*E2STKI	M2M STK Get Input
AT*E2STKL	M2M STK Select Item
AT*E2STKM	M2M STK Set Up Menu
AT*E2STKN	M2M STK Envelope (Menu Selection)
AT*E2STKS	SIM Application Toolkit Settings
AT*E2STKTO	SIM Application Toolkit Settings
AT*EALR	Ericsson Audio Line Request
AT*EALS	Ericsson Request ALS Status
AT*EAMS	Ericsson Audio Mode Selection
AT*EARS	Ericsson Audio Ring Signal
AT*ECAM	Ericsson Call Monitoring
AT*ECPI	Ciphering Indicator
AT*ECSP	Ericsson Customer Service Profile
AT*EDIF	Ericsson Divert Function
AT*EDST	Ericsson Daylight Saving Time
AT*EENMEA	NMEA (GPS) Mode on UART2
AT*EGIR	Ericsson Group Item Read
AT*EIPS	Identity Presentation Set
AT*ELAM	Ericsson Local Audio Mode
AT*ELIN	Ericsson Line Set
AT*EMAR	Ericsson Master Reset
AT*EMIC	Ericsson Microphone Mode
AT*EMIR	Ericsson Music Mute Indication Request
AT*EPEE	Ericsson Pin Event

## 8. AT COMMAND SUMMARY

---

<i>AT Command</i>	<i>Description</i>
AT*EPNR	Ericsson Read SIM Preferred Network
AT*EPNW	Ericsson Write SIM Preferred Network
AT*ESAG	Ericsson Add to Group
AT*ESCG	Ericsson Create Group
AT*ESCN	Ericsson Set Credit Card Number
AT*ESDG	Ericsson Delete Group
AT*ESDI	Ericsson Delete Group Item
AT*ESGR	Ericsson Group Read
AT*ESIL	Ericsson Silence Command
AT*ESLN	Ericsson Set Line Name
AT*ESMA	Ericsson Set Message Alert Sound
AT*ESMM	Ericsson Settings Minute Minder
AT*ESNU	Ericsson Settings Number
AT+CACM	Accumulated Call Meter
AT+CALA	Set Alarm
AT+CALD	Alarm Delete
AT+CAMM	Accumulated Call Meter Maximum
AT+CAOC	Advice of Charge
AT+CBST	Select Bearer Service Type
AT+CCFC	Call Forwarding Number and Conditions
AT+CCLK	Set Clock and Date
AT+CCWA	Call Waiting
AT+CEER	Extended Error Report
AT+CFUN	Set ME Functionality
AT+CGACT	PDP Context Activate or Deactivate
AT+CGATT	GPRS Attach or Detach
AT+CGDATA	Enter Data State
AT+CGDCONT	Define PDP Context
AT+CGEREP	GPRS Event Reporting
AT+CGMI	Read MS Manufacturer Identification
AT+CGMM	Read MS Model Identification
AT+CGMR	Read MS Revision Identification
AT+CGPADDR	Show PDP Address

## 8. AT COMMAND SUMMARY

---

<i>AT Command</i>	<i>Description</i>
AT+CGQMIN	Quality of Service Profile (Minimum Acceptable)
AT+CGQREQ	Quality of Service Profile (Requested)
AT+CGREG	GPRS Network Registration Status
AT+CGSMS	Select Service for MO SMS Messages
AT+CGSN	Read MS Product Serial Number Identification
AT+CHLD	Call Hold and Multiparty
AT+CHSC	HSCSD Current Call Parameters
AT+CHSD	HSCSD Device Parameters
AT+CHSN	HSCSD Non Transparent Call Configuration
AT+CHSR	HSCSD Parameters Report
AT+CHSU	HSCSD Automatic User Initiated Upgrading
AT+CHUP	Hang Up Call
AT+CIMI	Subscriber Identification
AT+CIND	Indicator Control
AT+CLAC	List All Available AT Commands
AT+CLCK	Facility Lock
AT+CLIP	Calling Line Identification
AT+CLIR	Calling Line Identification Restriction
AT+CMEE	Mobile Equipment Error
AT+CMER	Mobile Equipment Event Reporting
AT+CMGC	Send Command
AT+CMGD	Delete Message
AT+CMGF	Message Format
AT+CMGL	List Message
AT+CMGR	Read Message
AT+CMGS	Send Message
AT+CMGW	Write Message to Memory
AT+CMOD	Call Mode
AT+CMSS	Send From Storage
AT+CMUX	Switch to 07.10 Multiplex Protocol
AT+CNMI	New Message Indications to TE
AT+CNUM	Subscriber Number
AT+COLP	Connected Line Identification on Presentation

## 8. AT COMMAND SUMMARY

---

<i>AT Command</i>	<i>Description</i>
AT+COPS	Operator Selection
AT+CPAS	ME Activity Status
AT+CPBF	Phonebook Find
AT+CPBR	Phonebook Read
AT+CPBS	ME Storage
AT+CPBW	Phonebook Write
AT+CPIN	PIN Control
AT+CPMS	Preferred Message Storage
AT+CPUC	Price Per Unit and Currency Table
AT+CPWD	Change Password
AT+CR	Service Reporting Control
AT+CRC	Cellular Result Code
AT+CREG	Network Registration
AT+CRES	Restore SMS Settings
AT+CRLP	Radio Link Protocol
AT+CSAS	Save Settings
AT+CSCA	Service Centre Address
AT+CSCB	Select Cell Broadcast Message Type
AT+CSCS	Select Character Set
AT+CSDH	Show Text Mode Parameters
AT+CSMP	Set Text Mode Parameters
AT+CSMS	Select Message Service
AT+CSQ	Signal Strength
AT+CSSN	Supplementary Service Notification
AT+CTZU	Automatic Time Zone Update
AT+CUSD	Unstructured Supplementary Service Data
AT+CVHU	Voice Hang-Up
AT+F___	Low Level Fax Commands
AT+GMI	Read Manufacturer Identification
AT+GMM	Read Model Identification
AT+GMR	Read Revision Identification
AT+ICF	Cable Interface Character Format
AT+IFC	DTE-DCE Local Flow Control



## 8. AT COMMAND SUMMARY

---

<i>AT Command</i>	<i>Description</i>
AT+ILRR	Cable Interface Local Rate Reporting
AT+IPR	Cable Interface Port Command
AT+VTS	DTMF and Tone Generation
AT+WS46	Mode Selection
ATA	Answer
ATD	Dial
ATE	Command Echo
ATH	Hang up
ATI	Identification Information
ATL	Monitor Speaker Loudness
ATM	Monitor Speaker Control
ATO	Return to Online Data Mode
ATP	Select Pulse Dialling
ATQ	Result Code Suppression
ATS0	Automatic Answer Control
ATS2	Escape Sequence Character
ATS3	Command Line Termination Character
ATS4	Response Formatting Character
ATS5	Command Line Editing Character (BACKSPACE)
ATS6	Blind Dial Delay Control
ATS7	Connection Completion Timeout
ATS8	Comma Dial Modifier Delay Control
ATS10	Automatic Disconnect Delay Control
ATT	Select Tone Dialling
ATV	DCE Response Format
ATX	Call Progress Monitoring Control
ATZ	Reset to Default Configuration

## 9. Abbreviations and Definitions

<i>Abbreviation</i>	<i>Explanations</i>
CBM	Cell Broadcast Message
CBS	Cell Broadcast Service
CSD	Circuit Switched Data
DCE	Data Circuit Terminating Equipment
DTE	Data Terminal Equipment
DTMF	Dual Tone Multi Frequency
EFR	Enhanced Full Rate
EMC	Electro-Magnetic Compatibility
ETSI	European Telecommunication Standards Institute
FR	Full Rate
GPRS	General Packet Radio Service
GSM	Global System for Mobile Communication
High Side Switch	Pin is driven high, to $V_{in}$ , in the active state
HR	Half Rate
HSCSD	High Speed Circuit Switched Data
ITU-T	International Telecommunication Union - Telecommunications Standardisation Sector
Low Side Switch	Pin is driven low in the active state. <b>High state requires external pull up,</b>
ME	Mobile Equipment
MO	Mobile Originated
MS	Mobile Station
MT	Mobile Terminated
PDU	Protocol Data Unit
RLP	Radio Link Protocol
RF	Radio Frequency
RTC	Real Time Clock
SIM	Subscriber Identity Module
SMS	Short Message Service

## 9. ABBREVIATIONS AND DEFINITIONS

---

<i>Abbreviation</i>	<i>Explanations</i>
TA	Terminal Adapter
TE	Terminal Equipment
TS	Telecommunication Services
USSD	Unstructured Supplementary Service Data