

Contents

Getting started.....	4
Touch symbol.....	4
Assembly.....	4
Phone overview.....	5
Turning on the phone.....	5
More information.....	6
Charging the battery.....	7
Maximising battery performance.....	7
Antennas.....	7
Screen icons.....	8
Touch functionality.....	8
Menu overview.....	10
Navigation.....	11
Memory.....	12
Phone language.....	13
Entering text.....	13
Calling.....	15
Making and answering calls.....	15
Contacts	18
Speed dial.....	20
More calling features.....	20
Imaging.....	24
Using the still camera.....	24
Using the video camera.....	27
Working with photos.....	29
Accessing videos in your phone.....	32
Music	34
Accessing music in your phone.....	34
Stereo portable handsfree.....	35
Music player.....	35
PlayNow™.....	38
TrackID™	38
Online music and video clips.....	38
Radio	38
Record sound	40
Transferring and handling content.....	41
Handling content in the phone.....	41
Sending content to another phone.....	41
Using a USB cable.....	41

Transferring content to and from a computer.....	42
Phone name.....	43
Using Bluetooth™ wireless technology.....	43
Backing up and restoring.....	44
Updating your phone.....	45
Updating your phone using Sony Ericsson PC Suite.....	45
Update your phone wirelessly.....	45
Messaging.....	46
Text and picture messages.....	46
Conversations.....	47
Voice messages.....	47
Email.....	47
Internet	50
Web browser toolbar.....	50
Web browser shortcuts.....	50
Bookmarks.....	50
History pages.....	51
More browser features.....	51
Internet security and certificates.....	52
File transfers.....	52
Web feeds.....	52
Facebook™.....	53
Connected home.....	54
Wi-Fi™.....	54
DLNA™.....	54
Remote Play with PLAYSTATION®3.....	55
GPS.....	56
Using GPS.....	56
Google Maps™ for mobile.....	56
Driving directions.....	56
More GPS features.....	57
Synchronising.....	59
Synchronising using a computer.....	59
Synchronising using an Internet service.....	59
More features.....	60
Flight mode.....	60
Alarms.....	60
Calendar.....	61
Notes.....	61
Tasks.....	62
Profiles.....	62
Time and date.....	62

Themes.....	63
Main menu layout.....	63
Ringtones.....	63
Screen orientation.....	63
Games.....	64
Applications.....	64
Antivirus.....	64
PIN codes.....	65
IMEI number.....	66
Stereo Streaming Bluetooth™ Headset MH100.....	67
Introduction.....	67
Charging.....	67
Turning on and off.....	67
Pairing the headset.....	67
Adjusting the volume.....	68
Calling.....	68
Listening to music.....	69
Resetting headset.....	69
Battery.....	69
Troubleshooting.....	70
Troubleshooting.....	71
Common questions.....	71
Error messages.....	73
Index.....	75

Getting started

Touch symbol

 Instructions illustrated with a touch icon, or highlighted in grey, refer to touch screen functions only.

Assembly

Before you start using your phone, you need to insert a SIM card and the battery.

To insert the SIM card

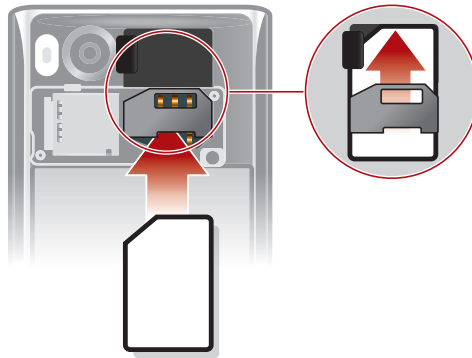

- 1 Remove the battery cover.
- 2 Slide the SIM card into its holder with the gold-coloured contacts facing down.

To insert the battery

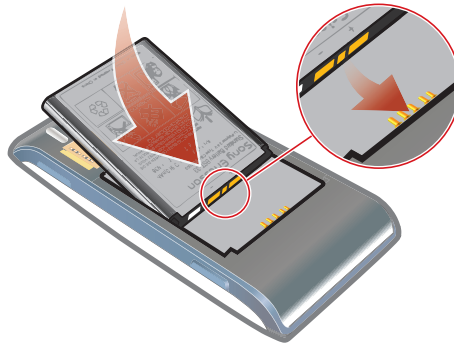

- 1 Insert the battery with the label side up and the connectors facing each other.
- 2 Attach the battery cover.

Phone overview

- 1 Ear speaker
- 2 Screen
- 3 Selection keys
- 4 Call key
- 5 Activity menu key
- 6 Navigation key
- 7 C key (Clear)
- 8 Volume key
- 9 End key, On/off key
- 10 Camera key/shutter key



- 11 Screen lock key
- 12 Flash light
- 13 Camera lens
- 14 Memory card slot (under the cover)
- 15 Connector for charger, handsfree and USB cable
- 16 Antenna
- 17 Loudspeaker

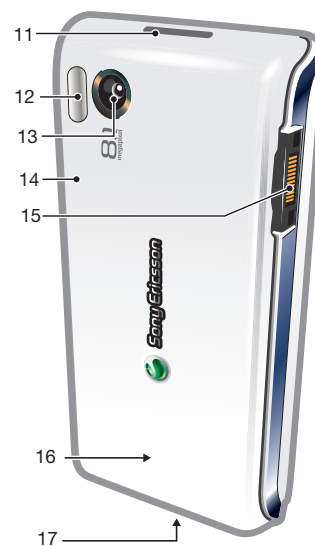

Turning on the phone

To turn on the phone

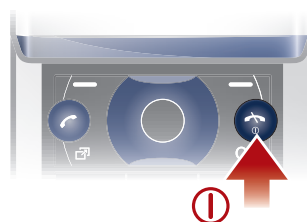

- 1 Press and hold down **(1)**.
- 2 Enter your SIM card PIN (Personal Identification Number), if requested, and select **OK**.
- 3 Select a language.
- 4 Follow the instructions that appear.

 If you want to correct a mistake when you enter your PIN, press **(C)**.

SIM card

The SIM (Subscriber Identity Module) card, which you get from your network operator, contains information about your subscription. Always turn off your phone and detach the charger before you insert or remove the SIM card.

 You can save contacts on the SIM card before you remove it from your phone.

PIN

You may need a PIN (Personal Identification Number) to activate the services and functions in your phone. Your PIN is supplied by your network operator. Each PIN digit appears as *, unless it starts with emergency number digits, for example, 112 or 911. You can see and call an emergency number without entering a PIN.

 If you enter the wrong PIN three times in a row, the SIM card is blocked. See *SIM protection* on page 65.

Standby

After you have turned on your phone and entered your PIN, the name of the network operator appears. This view is called standby. Your phone is now ready for use.

Using other networks

Making and receiving calls, using messaging, and data transfer, for example, Internet-based services, outside your home network (roaming), may incur additional costs. Contact your operator for more information.

More information

In addition to this User guide, Feature guides and more information are available at www.sonyericsson.com/support.

To access the User guide

- Select **Menu > Settings > User help > User guide**.

To view tips and tricks

- Select **Menu > Settings > User help > Tips and tricks**.

To view information about functions

- Scroll to a function and select **Info**, if available. In some cases, **Info** appears under **Options**.

To view the phone demonstration

- Select **Menu > Entertainment > Demo tour**.

To view the phone status

- Press the volume key. Phone, memory and battery information is shown.

Supported services and features

 Some of the services and features described in this User guide are not supported by all networks and/or service providers in all areas. Without limitation, this applies to the GSM International

Emergency Number 112. Please contact your network operator or service provider to determine availability of any specific service or feature and whether additional access or usage fees apply.

Charging the battery

The phone battery is partly charged when you buy it.

To charge the battery

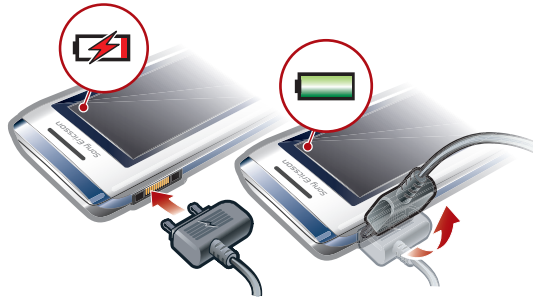

- 1 Connect the charger to the phone.
- 2 Remove the charger by tilting the plug upwards.

Maximising battery performance

- Charge your phone often. The battery lasts longer if you charge it frequently.
- If you are in an area with no coverage, your phone repeatedly scans for available networks. This consumes power. If you cannot move to an area with better coverage, turn off your phone temporarily.
- Turn off 3G, Bluetooth wireless technology and Wi-Fi™ when you do not need these functions.
- Do not cover the phone antenna when you are engaged in a call.



Antennas





























Avoid touching the antenna area unnecessarily while the antenna is transmitting or receiving. For example, avoid touching the phone antenna during a phone call. Also avoid covering your GPS antenna when you are using the GPS. Contact with a transmitting or receiving antenna affects the quality of the radio communication, may cause the phone to operate at a higher power level than otherwise needed, and may reduce battery life.



Go to www.sonyericsson.com/support to learn more about how to maximise your battery's performance.

Screen icons

These icons may appear on the screen:

Icon	Description
	The battery is almost fully charged
	The battery needs charging
	The network coverage is good
	No network coverage (also shown in flight mode)
	A 3G network is available
	A UMTS HSPA network is available
	Missed calls
	Calls diverted
	Ongoing call
	The microphone is muted
	The loudspeaker is on
	The phone is in silent mode
	New text message
	New multimedia message
	New email
	The music player is playing
	The radio is playing
	A handsfree is connected
	The Bluetooth function is activated
	A Bluetooth headset is connected
	The phone is connected to a Wi-Fi network
	The phone is connected to the Internet
	Secure website
	An alarm is activated
	Appointment reminder
	Task reminder
	GPS is activated
	A Java application is activated



Touch functionality

Your phone has touch functionality which is activated when the phone is closed.

Navigating the touch screen



Tap

Touch to select or activate an item on the screen.

**Drag**

Touch, hold and move an item from one place on the screen to another.

**Flick**

Touch and move your finger quickly left, right, up or down, respectively.

Touch and hold

Touch and let your finger remain on the item to activate it or to have an options menu appear.

Media browser overview

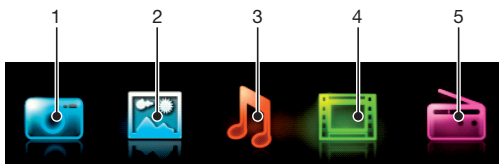

- 1 Camera
- 2 Photo
- 3 Music
- 4 Video
- 5 Radio

To navigate your Media Browser

- 1 Unlock the screen.
- 2 Tap one of the items.
- 3 To go back, tap on the top part of the screen or one of the Exit keys .



Using touch functionality

To activate the screen

- Press  on top of the phone.

To unlock the screen

- Drag  to the top of the screen.

To lock the touch functionality

- Press  on the top of the phone.

Menu overview*

PlayNow™

Camera

Location services

- Google Maps
- Navigation
- Tracker
- My favourites
- Settings

Calls**

- 

- All

- 

- Answered

- 

- Dialled

- 

- Missed

Internet

Messaging

- Write new
- Inbox/Conversations
- Messages
- Email
- Call voicemail

Contacts

- Myself
- New contact

Organiser

- Alarms
- Applications
- Media Home
- File manager **
- File transfer
- Calendar
- Tasks
- Notes
- Video call
- Synchronisation
- Timer

- Stopwatch

- Torch

- Calculator

Entertainment

- Online services

- Radio

- TrackID™

- Remote Play

- Games

- Photo Mate

- Record sound

- Demo tour

Media

- Photo

- Music

- Video

- Games

- Web feeds

- Settings

Music player

Settings

- General

- Profiles

- Time & date

- Language

- Update software

- Voice control

- Shortcuts

- Flight mode

- PIN codes

- Security

- Accessibility

- Phone status

- Master reset

- Sounds & alerts**

- Ring volume

- Ringtone

- Silent mode

- Increasing ring

- Vibrating alert

- Message alert

- Key sound

- Display**

- Wallpaper

- Main menu layout

- Theme

- Startup screen

- Screen saver

- Clock size

- Brightness

- Edit line names

- Calls**

- Speed dial

- Smart search

- Divert calls

- Switch to line 2

- Manage calls

- Time

- Show/hide my no.

- Handsfree

- Open to answer

- Close to end call

- Connectivity**

- Wi-Fi

- Bluetooth

- USB

- Phone name

- Content sharing

- Synchronisation

- Device management

- Mobile networks

- Data communication

- Internet settings

- Streaming settings

- Message settings

- SIP settings

- Accessories

- User help**

- User guide

- Settings download

- Basic setup

- Tips and tricks

* Some menus are operator-, network- and subscription-dependent.

** You can use the navigation key to scroll between tabs in submenus.

Navigation

To access the main menu

- When **Menu** appears on the screen, press the centre selection key to select **Menu**.
- If **Menu** does not appear on the screen, press , and then press the centre selection key to select **Menu**.

To navigate the phone menus



- Press the navigation key , ,  or  to move through the menus.

To select actions on the screen

- Press the left, centre or right selection key.

To view options for an item

- Select **Options** to, for example, edit.

To end a function

- Press .

To return to standby

- Press .

To navigate your media

- 1 Select **Menu > Media**.
- 2 Scroll to a menu item and press .
- 3 To go back, press .

To delete items

- Press  to delete items such as numbers, letters, pictures and sounds.

Tabs

Tabs may be available. For example, **Calls** have tabs.







To scroll between tabs

- Press the navigation key  or .

Shortcuts

You can use the navigation key shortcuts to go directly to functions from standby.

To use navigation key shortcuts

- Press , ,  or  to go directly to a function.

To edit a navigation key shortcut

- 1 Select **Menu > Settings > General > Shortcuts**.
- 2 Scroll to an option and select **Edit**.
- 3 Scroll to a menu option and select **Shortc..**

Main menu shortcuts

Menu numbering starts from the top left icon and moves across and then down row by row.

To go directly to a main menu item

- Select **Menu** and press (1) – (9), (*+), (0-) or (#+).
! The **Main menu layout** must be set to **Grid**. See *To change the main menu layout* on page 63.

Activity menu

The activity menu gives you quick access to:

- **New events** – missed calls and new messages.
- **Running apps** – applications that are running in the background.
- **My shortcuts** – add your favourite functions to access them quickly.
- **Internet** – quick access to the Internet.

To open the activity menu

- Press (☰).

Alerts and notifications

You can handle alarm alerts and get notifications of, for example, incoming messages and calendar events. When you dismiss a notification, you can view it later in the Activity menu.

To turn off or snooze an alarm

When the alarm is ringing:

- To turn off the alarm, drag the alarm icon to the right.



- To snooze the alarm, tap **Snooze**.

To dismiss a notification

- When you get a notification of an incoming email message or a calendar event, tap (✕).

Memory

You can save content on the memory card, in the phone memory and on the SIM card. Photos and music are saved on the memory card, if a memory card is inserted. If not, or if the memory card is full, photos and music are saved in the phone memory. Messages and contacts are saved in the phone memory, but you can choose to save them on the SIM card.

Memory card

- ! You may have to purchase a memory card separately.

Your phone supports a microSD™ memory card adding more storage space to your phone. It can also be used as a portable memory card with other compatible devices.

You can move content between a memory card and the phone memory.

To insert a memory card

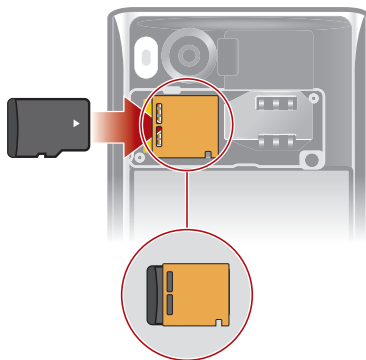

- Remove the battery cover and insert the memory card with the gold-coloured contacts facing down.

Phone language

You can select a language to use in your phone.

To change the phone language

- 1 Select **Menu > Settings > General > Language > Phone language**.
- 2 Select an option.

Entering text

You can use multitap text input or Quick text input  to enter text. The Quick text input method uses a dictionary application in your phone.

To change the writing language

- When you enter text, press and hold down .







To change the text input method

- When you enter text, press and hold down .



To shift between upper- and lower-case letters or numbers

- When you enter text, press .









To enter numbers

- 1 When you enter text, press  until  appears at the top of the screen.
 - 2 To enter a number, press  - .
-  To enter a number from text input mode, you can press and hold down  - .





To enter punctuation marks and symbols

- 1 When you enter text, press  briefly.
 - 2 Scroll to a symbol and select **Insert**.
-  To select from the most commonly used punctuation marks, you can also press .

To enter text using Quick text input

- 1 Select, for example, **Menu > Messaging > Write new > Message**.
- 2 If  is not displayed, press and hold down  to change to Quick text input.
- 3 Press each key only once, even if the letter you want is not the first letter on the key. For example, to write the word "Jane", press , , , . Write the whole word before looking at the suggestions.
- 4 To view word suggestions, press  or .
- 5 Press  to accept a suggestion and add a space.

To enter text using the multitap method

- 1 Select, for example, **Menu > Messaging > Write new > Message**.
- 2 If  is displayed, press and hold down  to change to multitap text input.
- 3 Press  –  repeatedly until the desired letter appears.
- 4 Press  to add a space.

To add words to the phone dictionary

- 1 When you enter text using Quick text input, select **Options > Spell word**.
- 2 Write the word using multitap input and select **Save**.

Calling

You need to turn on your phone and be within range of a network.

Making and answering calls

Answering calls

You can answer calls without opening the phone.

To answer a call when screen lock is on



- Drag  from left to right.

To answer a call when screen lock is off

- Tap .

To reject a call when screen lock is on

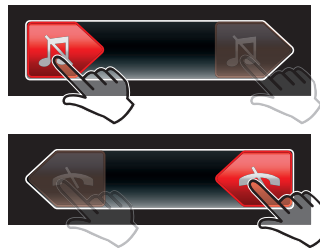

- Drag  to the right and then to the left.

To reject a call when screen lock is off

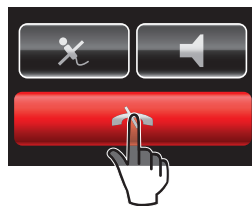

- Tap .

To mute the microphone during a call

- Tap .

To turn on a loudspeaker during a call

- Tap .

 Do not hold your phone to your ear when using the loudspeaker. This could damage your hearing.

To turn off the ringtone before answering a call when screen lock is on





- Drag  to the right.

To turn off the ringtone before answering a call when screen lock is off

- Tap .

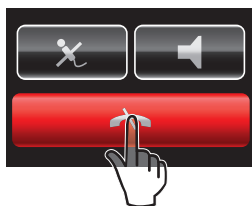
To end a call



- Tap on the  icon.

To make a call



- 1 Enter a phone number (with international country code and area code, if applicable).
- 2 Press .

 You can call numbers from your contacts and call list.

To end a call

- Press .

To make international calls

- 1 Press and hold down  until a “+” sign appears.
- 2 Enter the country code, area code (without the first zero) and phone number.
- 3 Press .

To re-dial a number

- When **Retry?** appears select **Yes**.

 Do not hold your phone to your ear when waiting. When the call connects, your phone gives a loud signal.

To answer a call

- Press .



To reject a call

- Press .

To change the ear speaker volume during a call

- Press the volume key up or down.

To mute the microphone during a call

- 1 Press and hold down .  appears.
- 2 Press and hold down  again to resume.

To turn on the loudspeaker during a call

- Select **Spkr on**.  appears.

 Do not hold the phone to your ear when using the loudspeaker. This could damage your hearing.



To view missed calls from standby

-  appears. Press  to open the call list.

Video call

During a video call, you can share video from the main camera.



Before making video calls

3G (UMTS) service is available when  or  appears. To make a video call, both parties on the call must have a 3G (UMTS) phone subscription that supports 3G (UMTS) service and 3G (UMTS) coverage.

To make a video call

- 1 Enter a phone number (with international country code and area code, if applicable).
- 2 Select **Options** > **Make video call**.

To use the zoom with an outgoing video call

- Press  or .

To share photos and videos during a video call

- 1 During a video call, press  to switch to the video share mode tab.
- 2 Scroll to a video clip or photo and select **Share**.

To view video call options

- During the call, select **Options**.

Emergency calls

Your phone supports international emergency numbers, for example, 112 or 911. You can normally use these numbers to make emergency calls in any country, with or without the SIM card inserted, if you are within range of a network.

- ! In some countries, other emergency numbers may also be promoted. Your network operator may therefore have saved additional local emergency numbers on the SIM card.

To make an emergency call

- Enter 112 (the international emergency number) and press .

To view your local emergency numbers

- 1 Select **Menu** > **Contacts**.
- 2 Scroll to **New contact** and select **Options** > **Special numbers** > **Emergency numbers**.

Networks

Your phone switches automatically between GSM and  (UMTS) or  networks depending on availability. Some network operators allow you to switch networks manually.



To switch networks manually

- 1 Select **Menu** > **Settings** > **Connectivity** > **Mobile networks** > **GSM/3G networks**.
- 2 Select an option.

Call list

You can view information about answered , dialled  and missed or rejected  calls.

To call a number from the call list

- 1 Press  and scroll to a tab.
- 2 Scroll to a name or a number and press .

Contacts

You can save names, phone numbers and personal information in **Contacts**. Information can be saved in the phone memory or on the SIM card.

 You can synchronise your contacts using the *Sony Ericsson PC Suite*.

Default contacts

You can choose which contact information is shown as default. If **Phone contacts** is selected as default, your contacts show all the information saved in **Contacts**. If you select **SIM contacts** as default, your contacts show names and numbers saved on the SIM card.

To select default contacts

- 1 Select **Menu > Contacts**.
- 2 Scroll to **New contact** and select **Options > Advanced > Default contacts**.
- 3 Select an option.

Phone contacts

Phone contacts can contain names, phone numbers and personal information. They are saved in the phone memory.

To add a phone contact



- 1 Select **Menu > Contacts**.
- 2 Scroll to **New contact** and select **Add**.
- 3 Enter the name and select **OK**.
- 4 Scroll to **New number:** and select **Add**.
- 5 Enter the number and select **OK**.
- 6 Select a number option.
- 7 Scroll between the tabs and add information to the fields.
- 8 Select **Save**.

Calling contacts



To call a contact

- 1 Select **Menu > Contacts**.
- 2 Scroll to a contact and press .

To go directly to the contacts list

- Press and hold down  – .

To call with Smart search

- 1 Press  –  to enter a sequence of (at least two) digits. All entries which match the sequence of digits or corresponding letters are shown in a list.
- 2 Scroll to a contact or a phone number and press .

To turn on or off Smart search

- 1 Select **Menu > Settings > Calls > Smart search**.
- 2 Select an option.

Editing contacts

To add information to a phone contact

- 1 Select **Menu** > **Contacts**.
- 2 Scroll to a contact and select **Options** > **Edit contact**.
- 3 Scroll between the tabs and select **Add** or **Edit**.
- 4 Select an option and an item to add or edit.
- 5 Select **Save**.

 If your subscription supports Calling Line Identification (CLI) service, you can assign personal ringtones and pictures to contacts.

To copy names and numbers to phone contacts

- 1 Select **Menu** > **Contacts**.
- 2 Scroll to **New contact** and select **Options** > **Advanced** > **Copy from SIM**.
- 3 Select an option.

To copy names and numbers to the SIM card

- 1 Select **Menu** > **Contacts**.
- 2 Scroll to **New contact** and select **Options** > **Advanced** > **Copy to SIM**.
- 3 Select an option.

 When you copy all contacts from your phone to the SIM card, all existing SIM card information is replaced.

To automatically save names and phone numbers on the SIM card

- 1 Select **Menu** > **Contacts**.
- 2 Scroll to **New contact** and select **Options** > **Advanced** > **Auto save on SIM**.
- 3 Select an option.

To save contacts on a memory card

- 1 Select **Menu** > **Contacts**.
- 2 Scroll to **New contact** and select **Options** > **Advanced** > **Back up to m. card**.

SIM contacts

SIM contacts can contain names and numbers only. They are saved on the SIM card.

To add a SIM contact

- 1 Select **Menu** > **Contacts**.
- 2 Scroll to **New contact** and select **Add**.
- 3 Enter the name and select **OK**.
- 4 Enter the number and select **OK**.
- 5 Select a number option and add more information, if available.
- 6 Select **Save**.

Deleting contacts

To delete all contacts

- 1 Select **Menu** > **Contacts**.
- 2 Scroll to **New contact** and select **Options** > **Advanced** > **Delete all contacts**.
- 3 Select an option.

Contact memory status

The number of contacts you can save in your phone or on the SIM card depends on available memory.

To view contact memory status

- 1 Select **Menu** > **Contacts**.
- 2 Scroll to **New contact** and select **Options** > **Advanced** > **Memory status**.

Myself

You can enter information about yourself and, for example, send your business card.

To enter Myself information

- 1 Select **Menu > Contacts**.
- 2 Scroll to **Myself** and select **Open**.
- 3 Scroll to an option and edit the information.
- 4 Select **Save**.

To add your own business card

- 1 Select **Menu > Contacts**.
- 2 Scroll to **Myself** and select **Open**.
- 3 Scroll to **My contact info** and select **Add > Create new**.
- 4 Scroll between the tabs and add information to the fields.
- 5 Enter the information and select **Save**.

Groups

You can create a group of phone numbers and email addresses from **Phone contacts** to send messages to. You can also use groups (with phone numbers) when you create accepted callers lists.

To create a group of numbers and email addresses

- 1 Select **Menu > Contacts**.
- 2 Scroll to **New contact** and select **Options > Groups**.
- 3 Scroll to **New group** and select **Add**.
- 4 Enter a name for the group and select **Continue**.
- 5 Scroll to **New** and select **Add**.
- 6 For each contact phone number or email address you want to mark, scroll to it and select **Mark**.
- 7 Select **Continue > Done**.

Speed dial

Speed dialling lets you select nine contacts that you can dial quickly from standby. The contacts can be saved in positions 1-9.

To add contacts to speed dial numbers

- 1 Select **Menu > Contacts**.
- 2 Scroll to **New contact** and select **Options > Speed dial**.
- 3 Scroll to a position number and select **Add**.
- 4 Select a contact.

To speed dial

- Enter the position number and press .

More calling features

Voicemail

If your subscription includes an answering service, callers can leave a voicemail message when you cannot answer a call.

To enter your voicemail number

- 1 Select **Menu > Messaging > Messages > Settings > the Message settings tab > Voicemail number**.
- 2 Enter the number and select **OK**.

To call your voicemail service

- Press and hold down .

Voice control

By creating voice commands you can:

- Voice dial – call someone by saying their name
- Answer and reject calls when you use a handsfree

To record a voice command using voice dialling

- 1 Select **Menu > Settings > General > Voice control > Voice dialling > Activate**.
 - 2 Select **Yes > New voice command** and select a contact. If the contact has more than one number, select the number to add the voice command to.
 - 3 Record a voice command such as “John mobile.”
 - 4 Follow the instructions that appear. Wait for the tone and say the command to record. The voice command is played back to you.
 - 5 If the recording sounds OK, select **Yes**. If not, select **No** and repeat steps 3 and 4.
- ! Voice commands are saved in the phone memory only. They cannot be used in another phone.

To voice dial

- 1 Press and hold down a volume key.
- 2 Wait for the tone and say a recorded name, for example “John mobile.” The phone plays the name back to you and connects the call.

To activate voice answering and record voice answer commands

- 1 Select **Menu > Settings > General > Voice control > Voice answer > Activate**.
- 2 Follow the instructions that appear and select **Continue**. Wait for the tone and say “Answer”, or say any other word.
- 3 Select **Yes** to accept or **No** for a new recording.
- 4 Wait for the tone and say “Busy”, or say any other word.
- 5 Select **Yes** to accept or **No** for a new recording.
- 6 Follow the instructions that appear and select **Continue**.
- 7 Select the environments in which you want to activate voice answering.

To answer a call using voice commands

- Say “Answer.”

To re-record a voice command

- 1 Select **Menu > Settings > General > Voice control > Voice dialling > Edit names**.
- 2 Scroll to a command and select **Options > Replace voice**.
- 3 Wait for the tone and say the command.

Diverting calls

You can divert calls, for example, to an answering service.

- ! When **Restrict calls** is used, some divert call options are not available.

To divert calls

- 1 Select **Menu > Settings > Calls > Divert calls**.
- 2 Select a call type and a divert option.
- 3 Select **Activate**.  appears.
- 4 Enter the number to divert calls to and select **OK**.

Call waiting

You will hear a beep if you receive a second call while call waiting is active.

To activate call waiting

- Select **Menu > Settings > Calls > Manage calls > Call waiting > Activate**.

More than one call

You can handle more than one call at a time. For example, you can put an ongoing call on hold, while you make or answer a second call. You can also switch between the two calls. You cannot answer a third call without ending one of the first two calls.

To switch between two calls

- During the call, press .



To join two calls

- During the call, select **Options** > **Join calls**.

To end an ongoing call and return to the call on hold

- First press  and then .

To make a second call

- 1 During the call, press . This puts the ongoing call on hold.
- 2 Select **Options** > **Add call**.
- 3 Enter the number to call and press .

To answer a second call

- During the call, press . This puts the ongoing call on hold.

To reject a second call

- During the call, press  and continue with the ongoing call.



To end an ongoing call and answer a second call

- During the call, select **Replace active call**.

Conference calls

With a conference call, you can have a joint conversation with up to five people.

To add a new participant

- 1 During the call, press . This puts the joined calls on hold.
- 2 Select **Options** > **Add call**.
- 3 Enter the number to call and press .
- 4 Select **Options** > **Join calls** to add the new participant.
- 5 Repeat this task to add more participants.

To release a participant

- 1 Select **Options** > **Release party**.
- 2 Select the participant to release.

To have a private conversation

- 1 During the call, select **Options** > **Talk to** and select the participant to talk to.
- 2 To resume the conference call, select **Options** > **Join calls**.

My numbers

You can view, add and edit your own phone numbers.

To check your phone numbers

- 1 Select **Menu** > **Contacts**.
- 2 Scroll to **New contact** and select **Options** > **Special numbers** > **My numbers**.
- 3 Select an option.

Accept calls

You can choose to receive calls from certain phone numbers only.

To add numbers to the accepted callers list

- 1 Select **Menu** > **Settings** > **Calls** > **Manage calls** > **Accept calls** > **Only from list**.
- 2 Scroll to **New** and select **Add**.
- 3 Select a contact or **Groups**.

To accept all calls

- Select **Menu** > **Settings** > **Calls** > **Manage calls** > **Accept calls** > **All callers**.

Restricted dialling

You can restrict outgoing and incoming calls. A password from your service provider is required.

- ! If you divert incoming calls, you cannot use some restrict calls options.

Restrict calls options

Standard options are:

- **All outgoing** – all outgoing calls
- **Outgoing intl** – all outgoing international calls
- **Outgoing intl roam.** – all outgoing international calls except to your home country
- **All incoming** – all incoming calls
- **Inc. when roaming** – all incoming calls when you are abroad

To restrict calls

- 1 Select **Menu** > **Settings** > **Calls** > **Manage calls** > **Restrict calls**.
- 2 Select an option.
- 3 Select **Activate**.
- 4 Enter your password and select **OK**.

Call time and cost

During a call, the phone shows how long you have been talking. You can also check on the duration of your last call, your outgoing calls and the total time of all your calls.

To check the call time

- Select **Menu** > **Settings** > **Calls** > **Time** > **Call timers**.



Showing or hiding your phone number

You can decide to show or hide your phone number when you make a call.

To hide your phone number

- 1 Select **Menu** > **Settings** > **Calls** > **Show/hide my no..**
- 2 Select **Hide number**.

Imaging



You have to use the camera when the phone is closed. You can take photos and record videos to view, save or send. When the phone is closed, you can find saved photos and videos in  or . When the phone is open, you can find saved photos and videos in **Media** and in **File manager**.

To activate the camera





- Tap .

Using the still camera

To take a photo by tapping the screen

- 1 Activate the camera.
- 2 If the still camera is not selected, tap .
- 3 Tap .
- 4 Tap a spot in the viewfinder where you want the focus to be. The photo is taken as soon as focus is set. The photo is automatically saved.
- 5 To return to the viewfinder and to take another photo, press .



To take a photo using the shutter key

- 1 Activate the camera.
- 2 If the still camera is not selected, tap .
- 3 Tap .
- 4 Press  halfway down to use auto focus. When the dot and focus frame are green, press  fully down to take a photo. The photo is saved automatically.
- 5 To return to the viewfinder and to take another photo, press .

To use zoom

- Press the volume key.

To select still camera settings

- 1 Activate the camera.
- 2 If the still camera is not selected, tap .
- 3 Tap .
- 4 Tap the lower part of the screen to display the settings bar.

Face detection

You can use face detection to bring an off-centre face into focus. The camera automatically detects up to three faces, indicated by white frames. A green frame shows which face has been selected for focus. Focus is set to the face closest to the camera.

To use Face detection











- 1 Activate the camera.
- 2 If the still camera is not selected, tap .
- 3 Tap .
- 4 Tap the lower part of the screen to display the settings bar.
- 5 Tap  and then .
- 6 Tap the screen to take the photo. The photo is taken as soon as focus is set. The photo is saved automatically.
- 7 To return to the viewfinder and to take another photo, press .

Photo fix















You can use Photo fix to improve a photo you have taken. In a one-tap operation, brightness, light and contrast are adjusted to give you the best possible photo. The improvements are saved as a copy of the photo. The original photo is not affected.











To improve a photo with Photo fix

- 1 Take a photo.
- 2 During review, tap the screen to display the toolbar.
- 3 Tap .
- 4 Tap .
- 5 Review the improvement and tap  to save.
- 6 If you do not want to save the improvement select .

 You can apply Photo fix on a photo several times.

Still camera settings

Icon	Setting	Description
	Scenes	Use Scenes to quickly set up the camera for common situations using pre-programmed scenes. The camera has determined a number of settings for you to fit the selected scene, ensuring the best possible photo.
	Auto	The camera automatically adjusts settings for a photo.
	Portrait	Use for portrait photos. Face detection is turned on. Settings are optimised to give slightly softer skin tones.
	Twilight portrait	Use for portrait photos at night or in poorly lit environments (with or without the flash). Due to long exposure time, the camera must be held still or placed on a stable surface.
	Sports	Use for photos of fast-moving objects. Short exposure time minimises motion blurring.
	Snow & beach	Use in bright environments to avoid underexposed photos.
	Landscape	Use for landscape photos. The camera focuses on distant objects. The flash is turned off.
	Twilight landscape	Use when taking landscape photos at night or in poorly lit environments (without the flash). Due to long exposure time, the camera must be held still or placed on a stable surface.
	Document	Use for photos of text or drawings. It gives the photo increased and sharper contrast.
	Focus	Focus controls which part of a photo should be sharp.
	Auto	The camera automatically focuses on the selected subject. The white focus frame turns green when focus is set.
	Face detection	The camera automatically detects up to three human faces, indicated by white frames. A green frame shows which face has been selected when auto focus is used. Focus is set on the face closest to the camera. Face detection cannot be used for all scene types.
	Macro	Auto focus for extreme close-up photos.
	Infinite	Use when taking photos at a distance. Focus is set on subjects far away. Subjects close to the camera may be blurred.
	Flash	Use the flash to take photos when lighting conditions are poor.
	Auto	The flash will automatically fire when lighting conditions are poor.
	Off	The flash never goes off, regardless of lighting conditions. Sometimes photo quality can be better without a flash, even if lighting conditions are poor. Taking a good photo without using the flash requires a steady hand. You can use the self-timer to avoid a blurred photo.
	Self-timer	With the self-timer you can take a photo without holding the phone. Use it to take self-portraits, or group photos

	On, 10s	where everyone can be in the photo. You can also use the self-timer to avoid shaking the camera when taking photos.
	On, 2s	Sets a 10-second delay from when the shutter key is pressed until the photo is taken.
	Off	It can be hard to hold the phone perfectly still when pressing the shutter key, which may result in a blurred photo. Use the 2-second delay to solve this problem.
Picture size		The photo is taken as soon as you press the shutter key.
You can select between several picture sizes and aspect ratios before taking a photo. Note that a photo with a higher resolution requires more memory.		
	8MP	8 megapixel picture size with 4:3 aspect ratio. Suitable for photos you want to view on non-widescreen displays or print in high resolution.
	7MP	7 megapixel picture size with 3:2 aspect ratio. This is the ratio used for traditional photos. Printed photos will fit most frames and photo albums.
	6MP	6 megapixel picture size with 16:9 aspect ratio. A high resolution widescreen format. Has a higher resolution than full HD. Suitable for photos you want to view on widescreen displays.
	3MP	3 megapixel picture size with 4:3 aspect ratio. Suitable for photos you want to view on non-widescreen displays.
	Full HD	Full high-definition format with 1920x1080 pixels. Suitable for photos you want to view on a widescreen HD TV.
Add geotags		You can tag photos with details of where you took them. Show friends and family where you were on a map, or use geotags to find your way back to the location another time.
	Off	When turned off, you are not able to view the location of where you took a photo on a map.
	On	When turned on, the approximate geographical location is added to photos when you take them. This information can later be used to identify the location where the photo was taken. You can view your photos on a map in Media > Photo .

Tips on using the camera

Rule of thirds

Don't place your subject in the middle of the frame. By placing it a third of the way in, you achieve a better result.

Hold it steady

Avoid blurry photos by holding the camera steady. Try to steady your hand by leaning it against a solid object. You can also use the self-timer to make sure that the phone is steady when the photo is taken.

Get closer

By getting as close as possible to your subject, you won't have to rely on the zoom. Try to fill the viewfinder with your subject.

Stay within the flash range

Photos taken beyond the maximum flash range will be too dark. The maximum flash range is about four steps from the subject.

Consider variety

Think about different angles, move towards the object. Take some vertical photos. Try different positions.

Use a plain background







A plain background helps highlight your subject.

Keep your lens clean





Mobile phones are used in all kinds of weather and places, and carried in pockets and bags. This results in the camera lens becoming dirty and covered with fingerprints. Use a soft cloth to clean the lens.

Using the video camera



To record a video by tapping the screen

- 1 Activate the camera.
- 2 If the video camera is not selected, tap .
- 3 Tap .
- 4 To start recording, tap the screen.
- 5 To pause the recording, tap . To continue recording, tap .
- 6 To stop recording, tap . The video is saved automatically.
- 7 To return to the viewfinder and to record another video, tap .





To record a video using the shutter key









- 1 Activate the camera.
- 2 If the video camera is not selected, tap .
- 3 Tap .
- 4 Press  to start recording.
- 5 To stop recording, press . The video is saved automatically.
- 6 To return to the viewfinder and to record another video, press .

To select video camera settings

- 1 Activate the camera.
- 2 If the video camera is not selected, tap .
- 3 Tap .
- 4 Tap the lower part of the screen to display the settings bar.

Video camera settings

Icon	Setting	Description
	Video format	Select the size and aspect ratio of a video before you record it.
	nHD	640x352 pixels video size with 16:9 aspect ratio. A widescreen format suitable for videos you want to view on widescreen displays.
	VGA	640x480 pixels video size. Standard video format for video cameras and computer screens.
	Message	Record videos suitable for sending in multimedia messages. The recording time of this video format is limited to fit in a multimedia message.
	Night mode	Use when lighting conditions are poor.
	On	When turned on, light sensitivity is increased. Use in poorly lit environments. Videos of fast-moving objects may get blurred. Hold your

		Off	hand steady, or use a support. Turn off night mode when lighting conditions are good, to improve the video quality.
	Light		Select whether you want to use the light when you record a video.
		On	Turn on the light to improve close-up videos in poorly lit environments.
		Off	The light is always turned off regardless of lighting conditions. Note: Sometimes a video gets better without the light, even if lighting conditions are poor. To record a good-quality video without using the light requires a steady hand. You can also use a support and the self-timer to avoid a blurred video.
	Microphone		Select whether to pick up the surrounding sound when recording videos.
		Off	When turned off, no sound is recorded with the video.
		On	When turned on, sound is recorded with the video.
	Self-timer		With the self-timer you can record a video without holding the phone. Use it to record a video where everyone can be in it. You can also use the self-timer to make sure that the phone is steady when the video is recorded.
		On, 10s	Sets a 10-second delay from when the shutter key is pressed until the video recording starts.
		On, 2s	It can be hard to hold the phone perfectly still when pressing the shutter key, which may result in a blurred video. Use the 2-second delay to solve this problem.
		Off	When the self-timer is off, the video recording starts as soon as you press the shutter key.
	Image stabiliser		Compensates for small movements of the hand to avoid blurred videos.
		On	The recommended setting. Use to avoid blurred videos.



Off

Working with photos

You can view, enhance and organise photos and videos on your computer by installing the *Adobe™ Photoshop™ Album Starter Edition*. It is available for download at www.sonyericsson.com/support.

Use theMedia Go™ application to transfer content to and from your phone. For more information, see *Transferring content to and from a computer* on page 42.

Editing photos

To delete a photo

- 1 Tap
- 2 Flick through the photos and videos.
- 3 Select a photo.
- 4 Tap the photo to view the tool bar.
- 5 Tap to delete a photo.

To edit a photo

- 1 Tap
- 2 Flick through the photos and videos.
- 3 Select a photo.
- 4 Tap the photo to view the tool bar.
- 5 Tap
- 6 Tap to apply black and white.
- 7 Tap to apply Photo fix.

To zoom a photo

- 1 Tap
- 2 Flick through the photos and videos.
- 3 Select a photo.
- 4 Tap the photo to view the tool bar.
- 5 Tap
- 6 Drag to zoom the photo.

Viewing photos on a map

When you take a photo, you can attach your geographical position to it. This is called geo tagging. Geo-tagged photos are tagged with in **Media**. If you cannot view photos on a map, see *I cannot use Internet-based services* on page 71.

To view photos on a map

- 1 Select **Menu > Media > Photo > Camera album**.
- 2 Select a month.
- 3 Scroll to a photo and select **View**.
- 4 Select **Options > View on map**.

To turn on or off geo tagging

- 1 Activate the camera.
- 2 If the still camera is not selected, tap .
- 3 Tap .
- 4 Tap the lower part of the screen to display the settings bar.
- 5 Tap or .
- 6 Tap an option.

Photo tags

You can organise your photos with photo tags. You can create new tags, assign one or several tags to a photo, or remove a tag from a photo. Photos with the same tag are put

together under **Photo tags**. For example, you can add tag "Vacation" to all your vacation photos, and view them all in **Photo tags**, under the tag "Vacation".

To create a new photo tag

- 1 Select **Menu > Media > Photo > Camera album**.
- 2 Select a month.
- 3 Scroll to a photo and select **View**.
- 4 Press  and select **Options > Tag this photo**.

To tag photos





- 1 Select **Menu > Media > Photo > Camera album**.
- 2 Select a month.
- 3 Scroll to a photo and select **View**.
- 4 Press  and scroll to a tag.
- 5 Select **Options > Tag this photo**.
- 6 For each photo you want to tag, scroll to the photo and select **Options > Tag this photo**.

To delete a tag from a photo

- 1 When viewing a photo, press .
- 2 Scroll to a tag and select **Options > Delete tag**.

Viewing and tagging photos

To view photos and videos using the camera

- 1 Activate the camera.
- 2 Tap .
- 3 Tap .
- 4 Flick through your photos and videos. Tap the screen to display controls.
- 5 Videos are indicated by . Tap  to play a video.

To view photos and videos in the media browser

- 1 Tap .
- 2 Flick through the photos and videos.
- 3 Tap a photo or a video.

To view photos in a slide show

- 1 Select **Menu > Media > Photo > Cam. album**.
- 2 Select a month.
- 3 Scroll to a photo and select **View**.
- 4 Select **Options > Slide show**.
- 5 Select a mood.

Using photos

You can add a photo to a contact, use the photo during phone startup, as a wallpaper in standby or as a screen saver.



To use photos

- 1 Select **Menu > Media > Photo > Camera album**.
- 2 Select a month.
- 3 Scroll to a photo and select **View**.
- 4 Select **Options > Use as**.
- 5 Select an option.

Sharing photos and videos

You can take a picture or video, or view a picture or a video, and send it to another phone or to the web.

To send a photo or a video saved in the phone

- 1 Tap .
- 2 Select a photo or a video.
- 3 Tap the screen.
- 4 Tap .
- 5 Select **To web albums**, **As message**, **As email** or **Via Bluetooth**.
- 6 Open the phone.
- 7 Enter a recipient and select **Send**.

To send a photo or a video you have just captured

- 1 When you have captured a photo or a video, tap .
- 2 Select **To web albums**, **As message**, **As email** or **Via Bluetooth**.
- 3 Open the phone.
- 4 Enter a recipient and select **Send**.

Using web albums

If your subscription supports this service, you can send photos or videos to a web album. If you cannot send content to a web album, see *I cannot use Internet-based services* on page 71.

- ! Web services may require a separate license agreement between you and the service provider. Additional regulations and charges may apply. Contact your service provider for more information.

To send photos saved in your phone to a web album

- 1 Select **Menu > Media > Photo > Cam. album**.
- 2 Select a month and year.
- 3 Scroll to the photo and select **Options > Send > To web albums**.
- 4 Select a web album service. If requested, enter your login information.
- 5 Select an album, or add a new album.
- 6 Enter text and select **Send**.

To send videos saved in your phone to a web album

- 1 Select **Menu > Media > Video > Videos**.
- 2 Scroll to a video and select **Options > Send > To web albums**.
- 3 Select a web album service. If requested, enter your login information.
- 4 Select a web album, or add a new web album.
- 5 Enter some text and select **Send**.

To view web albums

- 1 Select **Menu > Media > Photo > Web albums**.
- 2 Select a web album.

To go to a Web address from contacts

- 1 Select **Menu > Contacts**.
- 2 Scroll to a contact and select **Open**.
- 3 Scroll to a Web address and select **Go to**.

Printing photos

You can print photos using a USB cable connected to a PictBridge™ compatible printer.

- 💡 You can also print using a Bluetooth compatible printer that supports the Object Push Profile.

To print photos using a USB cable

- 1 Select **Menu** > **Organiser** > **File manager** > **Camera album** > **Open**.
- 2 Select **Options** > **Mark** > **Mark several** or **Mark all**.
- 3 Select **Options** > **Print** and follow the instructions.
- 4 Connect the USB cable to the phone.
- 5 Connect the USB cable to the printer.
- 6 Wait for feedback in the phone.
- 7 Set printer settings if required and select **Print**.

 Disconnect and re-connect the USB cable if there is a printer error.

Accessing videos in your phone

When the phone is closed, you can browse and play videos using the video player in the media browser. You can find videos you recorded using the camera under **Camera album**. You can access other videos from **Videos**. When the phone is open, you can access your videos from **Media** and **File manager**. For more information about how to handle content in **File manager**, go to www.sonyericsson.com/support and download the *Managing content* Feature guide.

To play videos

- 1 Tap .
- 2 Tap a category.
- 3 Flick left or right to browse through your videos.
- 4 Tap the video you want to play.

To pause videos

- 1 Tap the screen to display the controls.
- 2 Tap .

To fast forward and rewind videos

- 1 Tap the screen to display the controls.
- 2 Touch and hold  or .



To move between videos

- Flick left to move to the next video, or flick right to move to the previous video.

To view a video zoomed in

- 1 Tap the screen to display the controls.
- 2 Tap .

To show subtitles

- 1 Tap the screen to display the controls.
- 2 If a video has subtitles,  is displayed. Tap .
- 3 Select a language.

To hide subtitles

- 1 Tap the screen to display the controls.
- 2 If a video has subtitles,  is displayed. Tap .
- 3 Tap **Off**.

Video player

To play videos

- 1 Select **Menu** > **Media** > **Video** > **Videos**.
- 2 Scroll to a title and select **Play**.

To stop playing videos

- Press the centre selection key.

To fast forward and rewind

- Press and hold down ⏩ or ⏪.

To move between videos

- Press ⏮ or ⏭.

To change the volume

- Press the volume key up or down.

To change the video screen size

- Press ⏏.

Music

You can listen to music, audio books and podcasts. Use the Media Go™ application to transfer content to and from your phone. For more information, see *Transferring content to and from a computer* on page 42.



Accessing music in your phone

When the phone is closed, you can browse and play music using the music player in the media browser. More music features are available in **Media** and **File manager**, which you can access when the phone is open.

To browse music

- 1 Tap .
- 2 Tap a category.
- 3 Flick left or right to browse through your music.
- 4 Tap an album or a playlist to view its content.
- 5 To go back, tap outside the list and then the top part of the screen.

To browse music using the slider

- 1 When browsing music, for example, albums, tap the lower part of the screen to display .
- 2 To browse your music, drag  left or right.





To play music

- 1 Tap .
- 2 Tap a category.
- 3 Flick left or right to browse through your music.
- 4 Tap an album or a playlist.
- 5 To play a track, tap the title.

To pause the music

- Tap .

To fast forward and rewind music

- Touch and hold  or .
-  You can also drag  right or left to fast forward or rewind.

To move between tracks

- Tap  or .

To view the current play queue

- Tap the album art.

To minimise the music player

- Tap .

To return to the music player

- Tap  in the lower part of the screen.

Playing music in random order

You can play tracks in playlists in random order. A playlist can be, for example, a playlist you have created yourself or an album.

To play tracks in random order

- In the music player, tap .

Shake control

To shuffle tracks

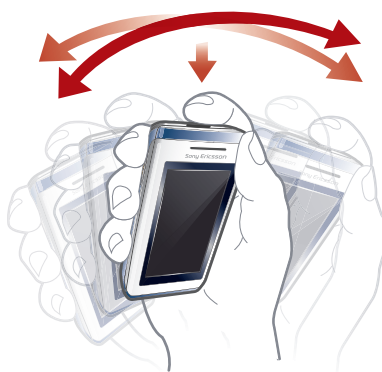

- When music is playing, press and hold down  and shake your phone.
- 💡 You can also shuffle tracks when the phone is open by shaking the phone.

Using the music mini player

You can use the music mini player for quick access to music controls when the screen lock is on.

To activate the music mini player

- 1 To view the screen, press  on top of the phone.
- 2 Tap the status bar at the bottom of the screen.

Stereo portable handsfree



To use a handsfree

- Connect a portable handsfree. Music stops when you receive a call and resumes when the call has ended.
- ! If headphones are not included with the phone, you may purchase them separately.

Music player

To play music

- 1 Select **Menu > Media > Music**.
- 2 Browse by category using the navigation key.
- 3 Scroll to a title and select **Play**.

To stop playing music

- Press the centre selection key.

To fast forward and rewind

- Press and hold down ⏩ or ⏪.

To move between tracks

- Press ⏩ or ⏪.

To change the volume

- Press the volume key up or down.

To minimise the player

- Select **Options** > **Minimise**.

To return to the player

- Select **Menu** > **Media**.



Clear stereo and clear bass

Clear stereo and clear bass are turned on when you set the equaliser manually.

To set the equaliser manually

- 1 Select **Menu** > **Media** > **Music**.
- 2 Browse by category using the navigation key.
- 3 Scroll to a title and select **Play**.
- 4 Select **Options** > **Settings** > **Equaliser**.
- 5 Make sure you are in Manual view. If you are not, select **Manual**.
- 6 To scroll between the frequency bands, press ⏩ or ⏪.
- 7 To change the value for a selected frequency band, press ⏴ or ⏵.
- 8 To go back to the player view, select **Done**.

To turn on clear stereo and clear bass using equaliser presets

- 1
- 2 Select **Menu** > **Media** > **Music**.
- 3 Browse by category using the navigation key.
- 4 Scroll to a title and select **Play**.
- 5 Select **Options** > **Settings** > **Equaliser**.
- 6 Make sure you are in Preset view. If you are not, select **Preset**.
- 7 To scroll between the presets, press  or .
- 8 Select any of the presets, except **Normal**.

Playlists

You can create playlists to organise your music. You can add tracks and folders to a playlist. It may take a few minutes for the phone to create a playlist.

To create a playlist

- 1 Select **Menu** > **Media** > **Music** > **Playlists**.
- 2 Scroll to **New playlist** and select **Add**.
- 3 Enter a name and select **OK**.
- 4 For each track you want to add, scroll to the track and select **Mark**.
- 5 Select **Add** to add the marked tracks to the playlist.

To add tracks to a playlist





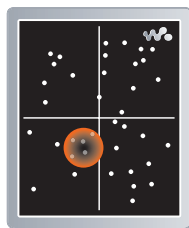





- 1 Select **Menu** > **Media** > **Music** > **Playlists**.
- 2 Select a playlist.
- 3 Scroll to **Add music** and select **Add**.
- 4 For each track you want to add, scroll to the track and select **Mark**.
- 5 Select **Add** to add the marked tracks to the playlist.

SensMe™













With SensMe™ you can create playlists in two ways, by mood or from all the tracks in your phone. By mood, you first use Media Go™ to transfer tracks to your phone. Information such as mood, tempo and chords is then added. The tracks are displayed as dots on a map with two axes. In the **All** view, all the tracks in your phone are placed randomly on the map.

To create a playlist by mood

- 1 Select **Menu > Media > Music**.
- 2 Scroll to **SensMe™** and select **Open**.
- 3 Press , ,  or .
- 4 Make sure you are in **Mood** view. If you are not, select **Mood**.
- 5 To preview different tracks, press , ,  or .
- 6 To choose an area of tracks, select **Add** and press  or .
- 7 To create the playlist and play it in the Walkman™ player, select **Create**.
- 8 Select **Options > Save playlist**.
- 9 Enter a name and select **OK**.

To create a playlist from All view

- 1 Select **Menu > Media > Music**.
- 2 Scroll to **SensMe™** and select **Open**.
- 3 Press , ,  or .
- 4 Make sure you are in **All** view. If you are not, select **All**.
- 5 To preview different tracks, press , ,  or .
- 6 To choose an area of tracks, select **Add** and press  or .
- 7 To create the playlist and play it in the Walkman™ player, select **Create**.
- 8 Select **Options > Save playlist**.
- 9 Enter a name and select **OK**.

Audio books

If you use Media Go™ to transfer audio books to your phone from a computer, you can listen to the audio books in your phone. It may take a few minutes before a transferred audio book appears in the list of available audio books.

To access audio books

- Select **Menu > Media > Music > Audio books**.
-  You can find audio books in formats other than M4B and those that do not have ID3v2 chapter tags in the **Tracks** folder.

Buy Now

If you subscribe to a music service allowing limited, non-permanent use with your phone, you can mark a track you are interested in buying later. The next time you synchronise your music with Windows Media® Player on a computer with enabled Internet access, you should be asked if you want to buy the track you marked earlier. If you accept, the track is downloaded to your computer and your selected music service account is charged. This service requires a subscription and account with a downloadable music service, a computer with Microsoft® Windows Media® Player 11 or subsequent compatible version of Windows Media® Player, and a USB computer connection.

- ! You cannot see that a track is marked. You cannot unmark tracks you have already marked.

To mark a track

- When the track you want to mark is playing, press and hold down .

PlayNow™

When you select **PlayNow™** you enter PlayNow™ arena, where you can download music, games, ringtones, themes and wallpapers. You can preview or listen to content before you purchase and download it to your phone. If you cannot use PlayNow™ and PlayNow™ arena, see *I cannot use Internet-based services* on page 71.

- ! This service is not available in all countries.

For extended functionality, you can also access the PlayNow™ arena Web shop on a computer from www.playnow-arena.com. For more information, go to www.sonyericsson.com/support to read the *PlayNow™ arena* Feature guide.

To use PlayNow™

- 1 Select **Menu > PlayNow™**.
- 2 Scroll through PlayNow™ arena and follow the instructions to preview and purchase content.

TrackID™

TrackID™ is a music recognition service. You can search for title, artist and album name for a track you hear playing through a loudspeaker or on the radio in your phone. If you cannot use TrackID™, see *I cannot use Internet-based services* on page 71.

To search for track information

- When you hear a track through a loudspeaker, select **Menu > Entertainment > TrackID™ > Start**.
 - When the radio in your phone is playing select **Options > TrackID™**.
- 💡 For best results, use TrackID™ in a quiet area.

Online music and video clips

You can view video clips and listen to music by streaming them to your phone from the Internet. If you cannot use the Internet, see *I cannot use Internet-based services* on page 71.

To select a data account for streaming

- 1 Select **Menu > Settings > Connectivity > Streaming settings > Connect using:**
- 2 Select the data account to use.
- 3 Select **Save**.

To stream music and video clips

- 1 Select **Menu > Internet**.
- 2 Select **Options > Go to > Bookmarks**.
- 3 Select a link to stream from.

Radio

- ! Do not use your phone as a radio in places where this is prohibited.

To turn on the radio

- 1 Connect a handsfree to the phone.
- 2 When the phone is closed, unlock the screen.
- 3 Tap .

To search for channels automatically

- Tap  or .

To search for channels using the slider

- Drag  through the frequency band.

To fine tune the frequency

- Tap  or .

To select saved channels

1 Tap .

2 Tap a channel.

- ! If  is unavailable there are no channels saved. To save channels, use the radio with the phone open.

To minimise the radio

- Tap .

To return to the radio

- Tap .

To turn off the radio

- Tap .

To turn on the radio

- 1 Connect a handsfree to the phone.
- 2 Select **Menu** > **Entertainment** > **Radio**.

To search for channels automatically

- Select **Search**.

To fine tune the frequency

- Press  or .

To change the volume

- Press the volume key up or down.

To minimise the radio

- Select **Options** > **Minimise**.

To return to the radio

- Select **Menu** > **Entertainment** > **Radio**.

Saving channels

You can save up to 20 preset channels.

To save channels automatically





- Select **Options** > **Channels** > **Auto save**.

To save channels manually

- 1 When you find a radio channel, select **Options** > **Channels** > **Save**.
- 2 Scroll to a position and select **Insert**.
- 3 If you want, you can rename the channel. Select **Save**.

- 💡 You can also save a channel in a position by pressing and holding down  - .

To switch between saved channels

- Press  or .
-  You can also select a saved channel by pressing  - .

Record sound

You can record a voice memo or a call. Recorded sounds can also be set as ringtones.

-  In some countries or states it is required by law that you inform the other person before recording the call.

To record a sound

- 1 Select **Menu** > **Entertainment** > **Record sound** > **Record**.
- 2 To stop recording and save, select **Save**.

To record a call

- 1 During an ongoing call, select **Options** > **Record**.
- 2 To save the recording, select **Save**.

To listen to a recording

- 1 Select **Menu** > **Organiser** > **File manager**.
- 2 Scroll to **Music** and select **Open**.
- 3 Scroll to a recording and select **Play**.

Transferring and handling content

You can transfer and handle content such as pictures and music.

- ! You are not allowed to exchange some copyright-protected material.  identifies a protected item.

Handling content in the phone

You can use **File manager** in your phone, to handle content saved in the phone memory or on a memory card. Tabs and icons in **File manager** show where the content is saved. If the memory is full, delete some content to create space.

To view memory status

- 1 Select **Menu > Organiser > File manager**.
- 2 Select **Options > Memory status**.
- 3 Select **Memory card** or **Phone**.

To select more than one item in a folder

- 1 Select **Menu > Organiser > File manager**.
- 2 Scroll to a folder and select **Open**.
- 3 Select **Options > Mark > Mark several**.
- 4 For each item you want to mark, scroll to the item and select **Mark**.

To move items between the phone memory and the memory card

- 1 Select **Menu > Organiser > File manager**.
- 2 Find an item and select **Options > Manage file > Move**.
- 3 Select **Memory card** or **Phone**.
- 4 Scroll to a folder and select **Open**.
- 5 Select **Paste**.

To view information about content

- 1 Select **Menu > Organiser > File manager**.
- 2 Find an item and select **Options > Information**.

Sending content to another phone

You can send content, for example, in messages or using Bluetooth wireless technology.

To send content

- 1 Scroll to an item and select **Options > Send**.
- 2 Select a transfer method.

- ! Make sure the receiving device supports the transfer method you select.

Using a USB cable

You can connect your phone to a computer with a USB cable. If you are using a PC, you are asked to install PC Companion the first time you connect.

- ! You may have to purchase a USB cable separately. Only use a USB cable supported by your phone.

PC Companion

PC Companion lets you:

- Explore content in your phone.
- Use your phone as a modem.
- Install PC Software used to synchronise, transfer and back up phone content.

For more information, go to www.sonyericsson.com/support to read Feature guides.

 To download Mac compatible software, go to www.sonyericsson.com/support.

To install PC Companion

- 1 Connect your phone to a PC using a USB cable supported by your phone.
- 2 **Computer:** Follow the instructions.

To disconnect the USB cable safely

 Do not disconnect the USB cable when transferring content as this may corrupt the content.

- 1 **Computer:** Right-click the Safely Remove Hardware icon in *Microsoft® Windows® Explorer*.
- 2 Select the drives you want to disconnect. Select *Stop*.
- 3 Wait until you are notified that it is safe to remove the drive. Disconnect the USB cable.

Required operating systems

You need one of these operating systems to use Sony Ericsson PC software:

- Microsoft® Windows Vista™
- Microsoft® Windows® XP, Service Pack 2 or higher

Drag and drop content

You can drag and drop content between your phone, a memory card and a computer in *Microsoft Windows Explorer*.

To drag and drop content

- 1 Connect your phone to a computer using a USB cable.
- 2 **Computer:** Wait until the phone memory and memory card appear as external disks in *Microsoft® Windows® Explorer*.
- 3 Drag and drop selected files between the phone and the computer.

Transferring content to and from a computer

You can use Media Go™ to transfer media content between your phone and a computer. Media Go™ is available for download through PC Companion or from www.sonyericsson.com/support.

 To download Mac® compatible software, go to www.sonyericsson.com/support.

To transfer content using Media Go™

- 1 Connect the phone to a computer with a USB cable supported by your phone.
- 2 **Computer:** Select *Start/Programs/Sony/Media Go™*.
- 3 Select *Transfer to or from Device using Media Go™* and click *OK*.
- 4 Wait until the phone appears in Media Go™.
- 5 Move files between your phone and the computer in Media Go™.

Media Home

You can use **Media Home** to transfer content automatically from Media Go™ to your phone. You can also use **Media Home** to download content from a DLNA server.

Before using **Media Home**, you must install Media Go™ on your computer and enable **Media sharing**. Media Go™ is available for download through PC Companion or from www.sonyericsson.com/support.

To set up Media Home

- 1 **Computer:** Turn on Media Go™ and enable *Media sharing*.
- 2 **Phone:** Start and complete the **Setup wizard**.

To automatically transfer content to your phone from Media Go™

- Connect the phone to the charger. **Media Home** will start an automatic download when a charger is connected.

To manually transfer content to your phone from Media Go™

- 1 Select **Organiser > Media Home**.
- 2 Press **Start**.

To browse and download content from a DLNA server

- 1 Select **Organiser > Media Home > Options > Browse**.
- 2 Select a server and mark the content you want to download.
- 3 Press **Download**.

Phone name

You can enter a name for your phone that is shown to other devices when using, for example, Bluetooth™ wireless technology.

To enter a phone name

- 1 Select **Menu > Settings > Connectivity > Phone name**.
- 2 Enter the phone name and select **OK**.

Using Bluetooth™ wireless technology

The Bluetooth™ function is free of charge and makes wireless connection to other Bluetooth devices possible. You can, for example:

- Connect to handsfree devices.
 - Connect to several devices at the same time.
 - Connect to computers and access the Internet.
 - Exchange items.
 - Play multiplayer games.
- ! A range within 10 metres (33 feet), with no solid objects in between, is recommended for Bluetooth communication.

Before using Bluetooth wireless technology

You must turn on the Bluetooth function to communicate with other devices. You may also have to pair your phone with other Bluetooth devices.

To turn on the Bluetooth function

- Select **Menu > Settings > Connectivity > Bluetooth > Turn on**.
- ! Make sure that the device you want to pair your phone with has the Bluetooth function activated and Bluetooth visibility turned on.

To pair the phone with another device

- 1 Select **Menu > Settings > Connectivity > Bluetooth > Add new device**.
- 2 Select a device.
- 3 Enter a passcode, if required.

To allow connection to the phone

- 1 Select **Menu > Settings > Connectivity > Bluetooth**.
 - 2 Select a device from the list.
 - 3 Select **Options > Allow connection**.
 - 4 Select **Always ask** or **Always allow**.
- ! This is only possible with devices that require access to a secure service.

Power saving

You can save battery power with the Power save function. In Power save mode you can only connect with a single Bluetooth device. If you want to connect with more than one Bluetooth device at the same time, you must turn off this function.

To turn on Power save

- Select **Menu > Settings > Connectivity > Bluetooth > Options > Power save > On.**

Transferring sound to and from a Bluetooth handsfree

You can transfer sound to and from a Bluetooth handsfree using a phone key or the appropriate key on the handsfree.

To transfer sound

- 1 Select **Menu > Settings > Connectivity > Bluetooth > Options > Incoming call.**
- 2 Select an option. **In phone** transfers sound to the phone. **In handsfree** transfers sound to the handsfree.

- ! You need to answer the call with the phone key for this setting to apply.

To transfer sound during a call

- 1 During a call, select **Sound.**
- 2 Select from the list of options available.

Backing up and restoring

You can back up and restore contacts, the calendar, tasks, notes and bookmarks using the *Sony Ericsson PC Suite*.

Before backing up and restoring, you need to install the *Sony Ericsson PC Suite*, which is available through PC Companion or from www.sonyericsson.com/support.

You can back up and restore contacts in your phone using a memory card. You can move content between the memory card and the phone memory. See *Handling content in the phone* on page 41.

- 💡 Back up your phone content regularly to make sure you do not lose it.

To make a backup using the Sony Ericsson PC Suite

- 1 **Computer:** Start the *Sony Ericsson PC Suite* from *Start/Programs/Sony Ericsson/Sony Ericsson PC Suite*.
- 2 Follow the instructions in the *Sony Ericsson PC Suite* on how to connect.
- 3 Go to the backup and restore section in the *Sony Ericsson PC Suite* and make a backup of your phone content.

To restore phone content using the Sony Ericsson PC Suite

- ! The *Sony Ericsson PC Suite* overwrites all phone content during the restore process. You may damage your phone if you interrupt the process.
- 1 **Computer:** Start the *Sony Ericsson PC Suite* from *Start/Programs/Sony Ericsson/Sony Ericsson PC Suite*.
 - 2 Follow the instructions in the *Sony Ericsson PC Suite* on how to connect.
 - 3 Go to the backup and restore section in the *Sony Ericsson PC Suite* and restore your phone content.

Updating your phone

You can update your phone to the most recent software for optimal performance and to get the latest enhancements. You need a USB cable and an Internet-connected PC.

To learn how, go to

www.sonyericsson.com/update.

- 💡 Remember to back up your phone content before updating. See *Backing up and restoring* on page 44.

Updating your phone using Sony Ericsson PC Suite

You can update your phone using a USB cable and *Sony Ericsson PC Suite*. When the phone is connected, it will automatically check for and notify you of new updates.

Update your phone wirelessly

You can update your phone over the air using the Update Service application in the phone. You do not lose personal or phone information.

- ! Update Service requires data access such as GPRS, 3G or HSDPA.

To select settings for Update Service

- Select **Menu > Settings > General > Update software > Settings > Internet settings**.

To use Update Service

- 1 Select **Menu > Settings > General > Update software**.
- 2 Select **Search for update** and follow the instructions that appear.

Messaging

Text and picture messages

Messages can contain text, pictures, sound effects, animations, and melodies. You can also create and use templates for your messages.



When sending messages, the phone automatically selects the most suitable method (as a text or picture message) for sending the message.

If you cannot use picture messages, see *I cannot use Internet-based services* on page 71.

Sending messages

You can send messages from your phone. The maximum size of a standard text message is 160 characters including spaces if no other items are added to the message. If you enter more than 160 characters, a second message is created. Your messages are sent as one concatenated message.

To create and send a message

- 1 Select **Menu** > **Messaging** > **Write new** > **Message**.
 - 2 Enter text. To add items to the message, press , scroll  and select an item.
 - 3 If you selected to use the camera: open the phone, take a picture or a video, and close the phone again to continue writing.
 - 4 Select **Continue** > **Contacts look-up**.
 - 5 Select a recipient and select **Send**.
- ! If you send a message to a group, you may be charged for each member. Contact your service provider for details.

To copy and paste text in a message

- 1 When you write the message, select **Options** > **Copy & paste**.
- 2 Select **Copy all** or **Mark & copy**. Scroll to and mark text in the message.
- 3 Select **Options** > **Copy & paste** > **Paste**.

Receiving and saving messages

You are notified when you receive a message.  or  appears. Messages are automatically saved in the phone memory. When the phone memory is full, you can delete messages or save them on a memory card or on the SIM card.

To save an incoming message on a memory card

- Select **Menu** > **Messaging** > **Messages** > **Settings** > **Save to** > **Memory card**.

To save a message on the SIM card

- 1 Select **Menu** > **Messaging** > **Messages** and select a folder.
- 2 Scroll to a message and select **Options** > **Save message**.

To view a message from the inbox

- 1 Select **Menu** > **Messaging** > **Messages** > **Inbox**.
- 2 Scroll to the message and select **View**.

To call a number in a message

- When you view the message, scroll to the phone number and press .

Message options

You can set some options, such as the Message alert and default storage location, to apply to all messages. You can set other options, such as the Delivery priority and Delivery time, for each message you send.

To set options for all messages

- 1 Select **Menu > Messaging > Messages > Settings**.
- 2 Select an option.

To set options for a specific message

- 1 When the message is ready and a recipient is selected, select **Options > Advanced**.
- 2 Scroll to an option and select **Edit**.

Conversations

You can choose whether to view your messages in **Conversations** or the **Inbox**. A messaging conversation shows all messaging communication between you and one of your contacts.

To view messages in Conversations

- Select **Menu > Messaging > Inbox > the Conversations** tab.
- Select **Menu > Messaging > Conversations** and select a conversation.

To send a message from Conversations

- 1 Select **Menu > Messaging**.
- 2 Select **Conversations**, or select **Inbox > the Conversations** tab.
- 3 Select a conversation.
- 4 Write a message and select **Send**.

Voice messages

You can send and receive a sound recording as a voice message.

- ! The sender and recipient must have a subscription supporting multimedia messaging.

To record and send a voice message

- 1 Select **Menu > Messaging > Write new > Voice message**.
- 2 Record the message and select **Stop > Send > Contacts look-up**.
- 3 Select a recipient and select **Send**.

Email

You can use standard email functions and your computer email address in your phone.

- 💡 You can synchronise your email using Microsoft® Exchange ActiveSync®.

Before using email

You can use the Basic setup to check if settings are available for your email account or you can enter them manually. You can also receive settings at www.sonyericsson.com/support.

To create an email account for the first time



- 1 To start the email setup wizard, select **Menu > Messaging > Email**.
 - 2 Follow the instructions to create the account.
- 💡 If you need to enter settings manually, you can contact your email provider for more information. An email provider could be the company that supplied your email address.

To write and send an email message

- 1 Select **Menu > Messaging > Email**.
- 2 If you have several email accounts, select the account you want to send the message from.
- 3 Select **Write new**.
- 4 To add a recipient, scroll to **To:** and select **Add > Enter email address**. Enter the email address and select **OK**.
- 5 To add more recipients, scroll to **To:** and select **Edit**. Scroll to an option and select **Add**. When you are ready, select **Done**.
- 6 To enter a subject, scroll to **Subject:**, select **Edit**, enter the subject, and select **OK**.
- 7 To enter the message text, scroll to **Text:**, select **Edit**, enter the text, and select **OK**.
- 8 Select **Add** to attach a file.
- 9 Select **Continue > Send**.

To receive and read an email message

- 1 Select **Menu > Messaging > Email**.
- 2 If you have several email accounts, select an account.
- 3 Select **Inbox > Options > Check new email**.
- 4 Scroll to the message and select **View**.

 You can be notified by  when you receive a new email. You will only get notifications from the active email account.

To save an email message

- 1 Select **Menu > Messaging > Email**.
- 2 If you have several email accounts, select an account.
- 3 Select **Inbox**.
- 4 Scroll to the message and select **View > Options > Save message**.

To reply to an email message

- 1 Select **Menu > Messaging > Email**.
- 2 If you have several email accounts, select an account.
- 3 Select **Inbox**.
- 4 Scroll to the message and select **Options > Reply**.
- 5 Write the reply and select **OK**.
- 6 Select **Continue > Send**.

To view an attachment in an email message

- When you view the message, select **Options > Attachments > Use > View**.

Active email account

If you have several email accounts, you can change which one is active. You can also automatically check for new email messages in the active account by setting a check interval.

To create additional email accounts

- 1 Select **Menu > Messaging > Email**.
- 2 If you have several email accounts, select an account.
- 3 Select **Accounts**.
- 4 Scroll to **New account** and select **Add**.

To change the active email account

- 1 Select **Menu > Messaging > Email**.
- 2 If you have several email accounts, select an account.
- 3 Select **Accounts**.
- 4 Select the account you want to activate.

To set the interval for checking for new email messages

- 1 Select **Menu > Messaging > Email**.
- 2 If you have several email accounts, select an account.
- 3 Select **Settings > the Download tab > Check interval**.
- 4 Select an option.

Push email

You can receive an immediate notification in your phone from your email server when you receive a new email message.

-  When using push email, the phone stays connected to the email server and normal traffic rates apply. Contact your network operator for details.

To turn on push email

- 1 Select **Menu > Messaging > Email**.
- 2 If you have several email accounts, select an account.
- 3 Select **Settings > the Download tab > Push email**.



Internet

If you cannot use the Internet, see *I cannot use Internet-based services* on page 71.

To start browsing





- 1 Select **Search**.
- 2 Enter a web address, a search phrase or the name of a bookmark.
- 3 Scroll to an item in the list and select **Go to** or **Search**.

To exit the browser

- 1 When you are browsing the web, select  and then select .
- 2 Select **Exit browser**.





Web browser toolbar

When you are viewing a web page, select . The following options appear:

Icon	Function
	Add the web page to your RSS feeds
	Pan and zoom the web page
	Manage your favourite web pages
	Manage the files you have downloaded from the Internet

Web browser shortcuts



You can use the keypad to go directly to a web browser function.

Key	Shortcut
	Bookmarks
 - 	Enter text to Enter address , Search Internet or search in Bookmarks
	Zoom
	Overview (when Smart-Fit is off)

Bookmarks

You can create and edit bookmarks as quick links to your favourite web pages.



To create a bookmark

- 1 When you are viewing a web page you want to add to your bookmarks, select  and then select .
- 2 Select **Add as bookmark**.

To select a bookmark

- 1 Select **Menu > Internet**.
- 2 When you are browsing the Internet, select  and then select .
- 3 Scroll to a bookmark and select **Go to**.

To send a bookmark

- 1 Select **Menu > Internet**.
- 2 When you are browsing the Internet, select  and then select .
- 3 Select  and scroll to a bookmark.
- 4 Select **Options > Send** and select a transfer method.

History pages

You can view and go to web pages you have previously visited.

To view history pages

- 1 Select **Menu** > **Internet**.
- 2 Select  and then .
- 3 Select **History**.

More browser features

To turn on or off Smart-Fit Rendering™



- 1 Select **Menu** > **Internet**.
- 2 Select  and then .
- 3 Select **Settings** > **Smart-Fit**.
- 4 Select an option.

- ! With Smart-Fit on, the web site is adjusted to your display to avoid horizontal scrolling. With Smart-fit off, you can pan and zoom while viewing a web site.



To make a call when you are browsing the web

- Press .



To save a picture from a web page

- 1 When you are viewing a web page, select  and then .
- 2 Select **Save picture**.
- 3 Select a picture.

To find text on a web page

- 1 When you are viewing a web page, select  and then .
- 2 Select **Find on page**.
- 3 Enter text and press **Find**.





To send a link

- 1 When you are viewing a web page, select  and then select .
- 2 Select **Send link** and select a transfer method.



- ! Make sure the receiving device supports the transfer method you select.

Internet keypad shortcuts

You can use the keypad to go directly to an Internet browser function.

Key	Shortcut
	Bookmarks
 - 	Enter text to Enter address , Search Internet or search in Bookmarks
	Zoom
	Overview (when Smart-Fit is off)

To use pan and zoom on a web page

- 1 When you are viewing a web page, select , then select .
- 2 Use the navigation key to move the frame.
- 3 Press the centre selection key to zoom in on a part of the web page.

- ! To use pan and zoom, **Smart-Fit** must be turned off.

Internet security and certificates

Your phone supports secure browsing. Certain Internet services, such as banking, require certificates in your phone. Your phone may already contain certificates when you buy it or you can download new certificates.

To view certificates in the phone

- Select **Menu** > **Settings** > **General** > **Security** > **Certificates**.

File transfers

The File transfer manager keeps track of the files you download from the Internet, for example media files, podcasts and games, and helps you access them. It also tracks your photo uploads to web sites, such as web albums and blogs. In the File transfer manager you also have the possibility to install downloaded Java applications, and to pause, resume and cancel downloads.



To access a file using File transfer

- 1 Select **Menu** > **Organiser** > **File transfer**.
- 2 Scroll to the file.
- 3 Press the centre selection key to access the file, or select **Options** for other actions.

Web feeds

You can subscribe to and download frequently updated content, such as news, podcasts or photos, using web feeds.



To add new feeds from a web page

- 1 When you browse a page on the Internet that provides web feeds, indicated by , select  and then .
- 2 For each feed you want to add, scroll to the feed and select **Add** > **Yes**.
- 3 Select an update frequency.

To search for web feeds

- 1 Select **Menu** > **Media** > **Web feeds**.
- 2 Select **New feed** and enter a web address.

To download content via web feeds

- 1 Select **Menu** > **Media** > **Web feeds**.
- 2 Select an updated web feed.
- 3 Scroll to an updated feed and select **View**.
- 4 Scroll to a heading by using  and .
- 5 Scroll to the item you want to download by using , then select **Options** > **Download file**.

 You can access downloaded files from the File transfer manager. See *File transfers* on page 52.

 You can also subscribe to and download web feed content to a computer using Media Go™. See *To transfer content using Media Go™* on page 42.

Updating web feeds

You can manually update your feeds, or schedule updates. When updates arrive,  appears on the screen.

To schedule web feed updates

- 1 Select **Menu** > **Media** > **Web feeds**.
- 2 Scroll to a feed and select **Options** > **Schedule update**.
- 3 Select an option.

 Frequent updates may be costly.

Web feeds in standby

You can show news updates on the standby screen.

To show web feeds in standby

- 1 Select **Menu > Media > Web feeds**.
- 2 Scroll to a feed and select **Options > Settings > Standby ticker > Show in standby**.

To access web feeds from standby

- 1 From standby, select **Ticker**.
- 2 To read more about a feed, press ⤴ or ⤵ to scroll to a headline and select **View**.

Podcasts

Podcasts are files, for example, radio programmes or video content, that you can download and play. You subscribe to and download podcasts using Web feeds.

To access audio podcasts

- Select **Menu > Media > Music > Music feeds**.

To access video podcasts

- Select **Menu > Media > Video > Video feeds**.

Photo feeds

You can subscribe to Photo feeds and download photos.

To access photo feeds

- Select **Menu > Media > Photo > Photo feeds**.

Facebook™

Facebook is a social utility that helps you communicate with your friends, family and coworkers.

To access Facebook

- Select **Menu > Organiser > Applications > Facebook**.

Connected home

Connected home makes the phone a part of everyday living in terms of music and media handling in home environment. It connects Hifi, TV, movies, gaming etc. on the home network.

Wi-Fi™

Using Wi-Fi™ you can access the Internet wirelessly with your phone. You can browse the Internet at home (personal networks) or in public access zones (hot spots):

- Personal networks – usually protected. A pass phrase or a key is required from the owner.
- Hot spots – usually non-protected but often requires you to log on to the operator's service before you get Internet access.

Using Wi-Fi

To be able to browse the Internet using Wi-Fi you need to search for and connect to an available network and then open the Internet browser.

To turn on Wi-Fi

- Select **Menu** > **Settings** > **Connectivity** > **Wi-Fi** > **Turn on**.

To connect to a network

- 1 Select **Menu** > **Settings** > **Connectivity** > **Wi-Fi**.
- 2 Scroll to a network and select **Connect**.

To start browsing using Wi-Fi

- 1 Make sure (📶) is showing in the status bar.
- 2 Select **Menu** > **Internet**.

- 💡 Often used networks can be saved as favourites. If you turn on **Auto connect** for one of these networks, your phone will connect automatically to that network when it is within range.

DLNA™

Your phone has a built-in DLNA™ (Digital Living Network Alliance) functionality that connects to your home network through Wi-Fi. Other DLNA devices connected to the same home network can access, view and play images and music saved in your phone. A compatible DLNA device can be, for example, a computer, camera, TV, PLAYSTATION®3 or another phone with DLNA functionality.

- ! **Wi-Fi** must be turned on and the phone must be connected to a favourite network

To set the phone as a DLNA server

- 1 Select **Menu** > **Settings** > **Connectivity** > **Content sharing**.
- 2 Select a favourite network from the list.
- 3 Select **On** > **Save**.

- 💡 A DLNA server exposes music, images and videos on the network. Other DLNA units play media from the media servers on the network.

To view photos saved in your phone on another DLNA device

- 1 Select **Menu** > **Media** > **Photo** > **Cam. album**.
- 2 Select a month.
- 3 Scroll to a photo and select **Options** > **View on**.
- 4 Select a DLNA device from the list.

To play music stored in your phone on another DLNA device

- 1 Select **Menu > Media > Music**.
- 2 Browse by category using the navigation key.
- 3 Scroll to and select a title.
- 4 Select **Options > Play on**.
- 5 Select a DLNA device from the list.

To play music stored on another DLNA device in your phone

- 1 Select **Menu > Media > Music > Media servers**.
- 2 Select a Media server from the list.
- 3 Browse by category using the navigation key.
- 4 Scroll to a title and select **Play**.

Remote Play with PLAYSTATION®3

Remote Play with PLAYSTATION 3 allows your phone to connect wirelessly to a PLAYSTATION 3 system. With Remote Play, you can access your PLAYSTATION 3 media content on your phone. You can control and view the PLAYSTATION 3 screen, including the menu, on your mobile phone. PLAYSTATION 3 will stream media to your phone. You can browse video, photos and music and download and watch game and movie trailers and images from PlayStation® Store. PlayTV* enables you to watch, record and search TV programs.

* Some functions are market dependent

- ! DRM protected media can not be streamed and played on your phone. For further information, please check the PLAYSTATION 3 website.

To start Remote Play with PLAYSTATION 3

- 1 Select **Menu > Entertainment > Remote Play > Start**.
- 2 Select **Yes > OK** to confirm creation of a eight digit registration code on PLAYSTATION 3.
- 3 Enter the eight digit registration code created in PLAYSTATION 3 and select **OK**.
- 4 Select **Via Wi-Fi**.
- 5 Select PLAYSTATION 3 from the list and select **OK**.

To stop Remote Play with PLAYSTATION 3

- 1 Select **Options > End Remote Play**.
- 2 Select **Yes** to turn of the PLAYSTATION 3 too

GPS

Your phone has a GPS receiver that uses satellite signals to calculate your location. Some GPS features use the Internet. Data rates and charges may apply.

- ! If you cannot use some GPS features, see *I cannot use Internet-based services* on page 71.

Using GPS

Your location can be found when you have a clear view of the sky. If your location is not found after a few minutes, move to another location. To help the search, stand still and do not cover the GPS antenna.

- ! The first time you use the GPS it may take up to 10 minutes before your location is found.

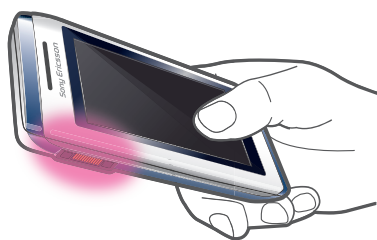

Assisted start

With **Assisted start** your location is calculated more quickly. If not turned off, **Assisted start** will automatically be used to find your location when Assisted GPS (A-GPS) technology is available.

To set when to use Assisted start

- 1 Select **Menu > Location services > Settings > Assisted start**.
- 2 Select an option.

Google Maps™ for mobile

Google Maps™ lets you view your current location, find other locations and calculate routes.

When you start Google Maps, your approximate location is shown using information from nearby mobile towers. Your location is updated with a more precise position when the GPS receiver finds your location.

To use Google Maps

- Select **Menu > Location services > Google Maps**.

To learn more about Google Maps

- When you use Google Maps, select **Options > Help**.

Driving directions

The Wisepilot™ application guides you to your destination using voice instructions. A trial version of the Wisepilot application may be included in the phone.

- ! Sony Ericsson does not warrant the accuracy of any directional services including but not limited to turn-by-turn navigational services.

To start Wisepilot

- Select **Menu > Location services > Navigation**.

More GPS features

Save locations

You can find all saved locations in **My favourites**.

To save your current location

- 1 Select **Menu** > **Location services** > **My favourites** > **Add new place**.
- 2 Select **Edit** and enter the title. Select **OK**.
- 3 Scroll to **Description:** and select **Add**.
- 4 Enter the description and select **OK**.
- 5 Scroll to **Position:** and select **Add** > **Current position**.
- 6 When the position is found, select **Save**.

To view a saved location on a map

- 1 Select **Menu** > **Location services** > **My favourites**.
- 2 Scroll to a location and select **Go to**.

To access favourites from Google Maps

- Press **(*)**.

Location requests

External services may ask for your location.

To change access for external services

- 1 Select **Menu** > **Location services** > **Settings** > **Privacy**.
- 2 Select an option.

Turn off GPS

The GPS receiver turns off automatically when it is not in use. You can also turn the GPS receiver off manually. This saves battery power when you use features that do not require the GPS receiver to find your location.

To turn on or off GPS manually

- 1 Select **Menu** > **Location services** > **Settings**.
- 2 Select **Enable GPS** or **Disable GPS**.

Tracker

Tracker is a GPS-based sports application which allows you to keep track of your speed, distance, route and energy consumption during training. You can base the training on how long time you want to train or on what distance you want to cover. You can also base it on a previous training route which has GPS data.

- ! Information provided by use of the Tracker application is approximate. Sony Ericsson makes no warranty of any kind with respect to the accuracy of the Tracker application. Any serious health and fitness concerns should be referred to a health care professional.

To start a training session

- 1 Select **Menu** > **Location services** > **Tracker** > **Start training**.
- 2 Select a training type.
- 3 Scroll to an item, select **Edit** and enter the data.
- 4 To save, select **Done**.
- 5 To start training, select **Start**.

To switch between training views

- During a training session, press **(◀)** or **(▶)** to view information on training duration, progress and live comparison with a previous session.

To compare results during training

- 1 Select **Menu** > **Location services** > **Tracker** > **Start training**.
- 2 Select **Route based**.
- 3 Scroll to **Route**; select **Edit** and select a route.
- 4 Scroll to **Live compare** and select **Edit**.
- 5 Scroll to the result you want to compare with and select **Compare**.
- 6 Select **Done** and then **Start**.

! A GPS location is required before results can be compared.

To end a training session manually

- During a training session, select **Pause** > **End**.

Results

The training result is shown after a session is ended. You can view past results anytime, and compare them if they have GPS data.

To view a training result

- 1 Select **Menu** > **Location services** > **Tracker** > **Results**.
- 2 Scroll to a month and select **View**.
- 3 Scroll to a date and select **View**.
- 4 Select a training result. If you have used laps, press ⌂ or ⌂ to view result per lap.

To compare results

- 1 Select **Menu** > **Location services** > **Tracker** > **Results**.
- 2 Scroll to a result and select **Options** > **Compare**.
- 3 Select a result to compare with.

! A GPS location is required before results can be compared.

Energy consumption

To calculate and view the energy consumption for a session you must first set your personal profile in **Settings** in Tracker. You view the energy consumption in the result view.

To set the personal profile

- 1 Select **Menu** > **Location services** > **Tracker** > **Settings** > **Personal profile**.
- 2 Select an item, enter data and select **OK**.
- 3 When finished, select **Options** > **Save profile**.

To turn on energy consumption

- Select **Menu** > **Location services** > **Tracker** > **Settings** > **Energy consumption** > **On**.

Synchronising

You can synchronise your phone in two different ways: using a computer program, or using an Internet service.

- 💡 Use only one of the synchronisation methods at a time with your phone.

For more information, go to www.sonyericsson.com/support to read the *Synchronisation* Feature guide.

Synchronising using a computer

You can use a USB cable or Bluetooth wireless technology to synchronise phone contacts, appointments, bookmarks, tasks and notes with Online Service or a computer program such as Microsoft® Outlook®.

Before synchronising, you need to install the *Sony Ericsson PC Suite*. *Sony Ericsson PC Suite* software is available for download through PC Companion or from www.sonyericsson.com/support.

- 💡 To download Mac compatible software, go to www.sonyericsson.com/support.

To synchronise using the Sony Ericsson PC Suite

- 1 **Computer:** Start *Sony Ericsson PC Suite* from *Start/Programs/Sony Ericsson/Sony Ericsson PC Suite*.
- 2 Follow the instructions in the *Sony Ericsson PC Suite* for how to connect.
- 3 When you are notified that the *Sony Ericsson PC Suite* has found your phone, you can start synchronising.

- 💡 For usage details, see the *Sony Ericsson PC Suite* Help section once the software has been installed on your computer.

Synchronising using an Internet service

You can synchronise with an Internet service using SyncML™ or a Microsoft® Exchange Server using Microsoft Exchange ActiveSync. For more information, go to www.sonyericsson.com/support to read the *Synchronisation* Feature guide.

More features

Flight mode

In **Flight mode** the network and radio transceivers are turned off to prevent disturbance to sensitive equipment.

When the flight mode menu is activated you are asked to select a mode the next time you turn on your phone:

- **Normal mode** – full functionality
- **Flight mode** – limited functionality

To activate the flight mode menu

- Select **Menu > Settings > General > Flight mode > Continue > Show at startup**.

To select flight mode

- 1 When the flight mode menu is activated, turn off your phone.
- 2 Turn on your phone and select **Flight mode**.  appears.

Alarms

You can set a sound or the radio as an alarm signal. The alarm sounds even if the phone is turned off. When the alarm sounds you can silence it or turn it off.

To set the alarm

- 1 Select **Menu > Organiser > Alarms**.
- 2 Scroll to an alarm and select **Edit**.
- 3 Scroll to **Time:** and select **Edit**.
- 4 Enter a time and select **OK > Save**.

To set the recurrent alarm

- 1 Select **Menu > Organiser > Alarms**.
- 2 Scroll to an alarm and select **Edit**.
- 3 Scroll to **Recurrent:** and select **Edit**.
- 4 Scroll to a day and select **Mark**.
- 5 To select another day, scroll to the day and select **Mark**.
- 6 Select **Done > Save**.

To set the alarm signal

- 1 Select **Menu > Organiser > Alarms**.
- 2 Scroll to an alarm and select **Edit**.
- 3 Scroll to the  tab.
- 4 Scroll to **Alarm signal:** and select **Edit**.
- 5 Find and select an alarm signal. Select **Save**.

To silence the alarm

- When the alarm sounds, press any key.
- To repeat the alarm, select **Snooze**.

To turn off the alarm

- When the alarm sounds, press any key, then select **Turn off**.

To cancel the alarm

- 1 Select **Menu > Organiser > Alarms**.
- 2 Scroll to an alarm and select **Turn off**.

The alarm in silent mode

You can set the alarm not to sound when the phone is in silent mode.

To set an alarm to sound or not in silent mode

- 1 Select **Menu > Organiser > Alarms.**
- 2 Scroll to an alarm and select **Edit.**
- 3 Scroll to the  tab.
- 4 Scroll to **Silent mode:** and select **Edit.**
- 5 Select an option.

To set the snooze duration

- 1 Select **Menu > Organiser > Alarms.**
- 2 Scroll to an alarm and select **Edit.**
- 3 Scroll to **Snooze duration:** and select **Edit.**
- 4 Select an option.

Calendar

-  You can synchronise your calendar with a computer calendar, with a calendar on the Web or with a Microsoft® Exchange Server (Microsoft® Outlook®).

Appointments

You can add new appointments or reuse existing appointments.

To add an appointment

- 1 Select **Menu > Organiser > Calendar.**
- 2 Select a date.
- 3 Scroll to **New entry** and select **Add.**
- 4 Enter the information and confirm each entry.
- 5 Select **Save.**

To view an appointment

- 1 Select **Menu > Organiser > Calendar.**
- 2 Select a date.
- 3 Scroll to an appointment and select **View.**

To edit an appointment

- 1 Select **Menu > Organiser > Calendar.**
- 2 Select a date.
- 3 Scroll to an appointment and select **View.**
- 4 Select **Options > Edit.**
- 5 Edit the appointment and confirm each entry.
- 6 Select **Save.**

To set when reminders should sound

- 1 Select **Menu > Organiser > Calendar.**
- 2 Select a date.
- 3 Select **Options > Advanced > Reminders.**
- 4 Select an option.

-  A reminders option set in calendar affects a reminders option set in tasks.

Notes

You can make notes and save them. You can also show a note in standby.

To add a note

- 1 Select **Menu > Organiser > Notes**.
- 2 Scroll to **New note** and select **Add**.
- 3 Write a note and select **Save**.

To show a note in standby

- 1 Select **Menu > Organiser > Notes**.
- 2 Scroll to a note and select **Options > Show in standby**.

To hide a note from standby

- 1 Select **Menu > Organiser > Notes**.
- 2 Scroll to the note shown in standby. This is marked with an icon. Select **Options > Hide in standby**.

Tasks

You can add new tasks or reuse existing tasks.

To add a task

- 1 Select **Menu > Organiser > Tasks**.
- 2 Select **New task** and select **Add**.
- 3 Select an option.
- 4 Enter details and confirm each entry.

To set when reminders should sound

- 1 Select **Menu > Organiser > Tasks**.
- 2 Scroll to a task and select **Options > Reminders**.
- 3 Select an option.

! A reminders option set in tasks affects a reminders option set in calendar.

Profiles

You can change settings such as the ring volume and vibrating alert to suit different locations. You can reset all profiles to the phone's original settings.

To select a profile

- 1 Select **Menu > Settings > General > Profiles**.
- 2 Select a profile.

To view and edit a profile

- 1 Select **Menu > Settings > General > Profiles**.
- 2 Scroll to a profile and select **Options > View and edit**.

! You cannot rename the **Normal** profile.

Time and date

To set the time

- 1 Select **Menu > Settings > General > Time & date > Time**.
- 2 Enter the time and select **Save**.

To set the date

- 1 Select **Menu > Settings > General > Time & date > Date**.
- 2 Enter the date and select **Save**.

To set the time zone

- 1 Select **Menu** > **Settings** > **General** > **Time & date** > **My time zone**.
- 2 Select the time zone you are in.

! If you select a city, **My time zone** also updates the time when daylight saving time changes.

To change the clock size of the standby screen

- 1 Select **Menu** > **Settings** > **Display** > **Clock size**.
- 2 Select an option.

Themes

You can change the appearance of the screen through items such as colours and wallpaper. You can also create new themes and download them. For more information, go to www.sonyericsson.com/fun.

To set a theme

- 1 Select **Menu** > **Settings** > **Display** > **Theme**.
- 2 Scroll to a theme and select **Set**.

Main menu layout

You can change the layout of the icons in the main menu.

To change the main menu layout



- 1 Select **Menu** > **Options** > **Main menu layout**.
- 2 Select an option.

Ringtones



To set a ringtone

- 1 Select **Menu** > **Settings** > **Sounds & alerts** > **Ringtone**.
- 2 Find and select a ringtone.

To set the ringtone volume

- 1 Select **Menu** > **Settings** > **Sounds & alerts** > **Ring volume**.
- 2 Press  or  to adjust the volume.
- 3 Select **Save**.

To turn off the ringtone

- Press and hold down .  appears.
- ! The alarm signal is not affected.

To set the vibrating alert

- 1 Select **Menu** > **Settings** > **Sounds & alerts** > **Vibrating alert**.
- 2 Select an option.

Screen orientation

You can change between landscape and portrait orientation, or select **Auto rotate** to have the orientation change when you rotate the phone.

To change screen orientation in the browser

- 1 Select **Menu** > **Internet**.
- 2 Select **Options** > **Advanced** > **Orientation**.
- 3 Select an option.

To change screen orientation in Media

- 1 Select **Menu > Media > Settings > Orientation**.
- 2 Select an option.

Games

Your phone contains preloaded games. You can also download games. For more information, go to www.sonyericsson.com/fun. Help texts are available for most games.

To start a game

- 1 Select **Menu > Media > Games**.
- 2 Select a game.

To end a game

- Press .

Applications

You can download and run Java applications. You can also view information or set different permissions. If you cannot use Java applications, see *I cannot use Internet-based services* on page 71.

To select a Java application

- 1 Select **Menu > Organiser > Applications**.
- 2 Select an application.

To set permissions for a Java application

- 1 Select **Menu > Organiser > Applications**.
- 2 Scroll to an application and select **Options > Permissions**.
- 3 Set permissions.

Java application screen size

Some Java applications are designed for a specific screen size. For more information, contact the application vendor.

To set the screen size for a Java application

- 1 Select **Menu > Organiser > Applications**.
- 2 Scroll to an application and select **Options > Screen size**.
- 3 Select an option.

To set a Java™ application as a wallpaper

- 1 Select **Menu > Settings > Display**.
- 2 Select **Wallpaper > Application**.
- 3 Select a Java application.

- ! You can only see the Java applications that have support for wallpaper.

Antivirus

Antivirus identifies and removes applications you install on your phone that become infected by viruses. It automatically scans applications during installation. When an infected application is detected, you can delete or release the infected application. You can select a 30-day free evaluation or enter a subscription number. We recommend that you update the antivirus application with the latest virus protection frequently. You need the correct Internet settings in your phone to use this function.

- ! Our inclusion or your use of antivirus software does not ensure that your use of this product will be free from exposure to viruses, malware or other harmful software.

To turn on Antivirus

- 1 Select **Menu > Settings > General > Security > Antivirus**.
- 2 Follow the instructions to use the setup wizard.

To turn off Antivirus

- 1 Select **Menu > Settings > General > Security > Antivirus > Virus scan**.
- 2 Select **Off**.

PIN codes

SIM protection

This lock only protects your subscription. Your phone will work with a new SIM card. If the lock is on, you have to enter a PIN (Personal Identity Number).

If you enter your PIN incorrectly three times in a row, the SIM card is blocked and you need to enter your PUK (Personal Unblocking Key). Your PIN and PUK are supplied by your network operator.

To unblock the SIM card

- 1 When **PIN blocked** appears, enter your PUK and select **OK**.
- 2 Enter a new four-to-eight-digit PIN and select **OK**.
- 3 Re-enter the new PIN and select **OK**.

To edit the PIN

- 1 Select **Menu > Settings > General > PIN codes > SIM protection > Change PIN**.
- 2 Enter your PIN and select **OK**.
- 3 Enter a new four-to-eight-digit PIN and select **OK**.
- 4 Re-enter the new PIN and select **OK**.

- ! If **Codes do not match** appears, you entered the new PIN incorrectly. If **Incorrect PIN** appears, you entered the old PIN incorrectly.

To use the SIM card lock

- 1 Select **Menu > Settings > General > PIN codes > SIM protection > Protection**.
- 2 Select an option.
- 3 Enter your PIN and select **OK**.

Phone protection

You can stop unauthorised use of your phone. Change the phone lock code (0000) to any four-to-eight-digit personal code.

- ! It is important that you remember your new code. If you forget it, you need to take your phone to your local Sony Ericsson retailer.

To use the phone lock

- 1 Select **Menu > Settings > General > PIN codes > Phone protection > Protection**.
- 2 Select an option.
- 3 Enter the phone lock code and select **OK**.

- 💡 When **Automatic** phone protection is activated the phone protection code must be entered when another SIM card is inserted.

To unlock the phone

- When **Phone locked** appears, enter your phone lock code and select **OK**.

To change the phone lock code

- 1 Select **Menu > Settings > General > PIN codes > Phone protection > Change code**.
- 2 Enter the old code and select **OK**.
- 3 Enter the new code and select **OK**.
- 4 Repeat the code and select **OK**.

IMEI number

Keep a copy of your IMEI (International Mobile Equipment Identity) number in case your phone is stolen.

To view your IMEI number

- Press **(*)**, **(#)**, **(0)**, **(6)**, **(#)**.

Stereo Streaming Bluetooth™ Headset MH100

- 1 Microphone
- 2 Call key
- 3 Earpiece connector
- 4 Volume touch area
- 5 On/off key
- 6 Charger connector
- 7 Next/Play-Pause/Previous keys
- 8 Music/battery/status light indicators

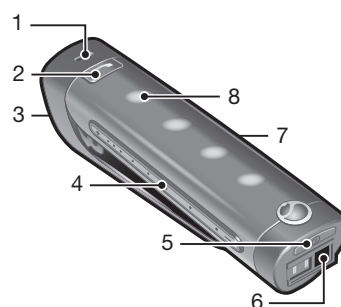

! If you are using a headset other than the MH100, go to www.sonyericsson.com/support for more information.

Introduction

The Stereo Streaming Bluetooth Headset MH100 lets you stay in control of your incoming and outgoing phone calls. You can enjoy stereo audio from a phone or other Bluetooth device, such as a computer or a portable music player. During calls, the music automatically pauses and starts playing again when the call ends.

Charging

Before using the headset for the first time, charge it with the supplied charger for 8 hours. The normal charging time is 2.5 hours.

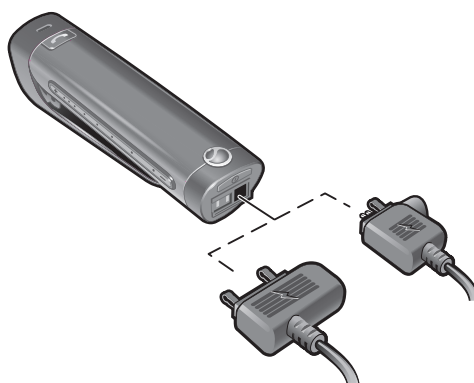

Turning on and off

To turn on the headset

- Press and hold down the on/off key until a light appears.

To turn off the headset

- Press and hold down the on/off key until the lights have disappeared.

Pairing the headset

The MH100 is already pre-paired with the phone it is shipped with. The MH100 and the phone connect automatically the first time you turn on this headset.

Pairing the headset with a different phone

If you want to use the headset with a different phone you need to pair the headset with that phone. After successful pairing, the headset connects automatically to the phone as soon as the headset is turned on and within range.

To pair the headset with a phone

- 1 Make sure the headset is turned off.
 - 2 Turn on the Bluetooth function in the phone. For instructions, see the phone User guide.
 - 3 Turn on Bluetooth visibility in the phone. This makes the phone visible to other Bluetooth devices.
 - 4 Place the phone within 20 cm (8 inches) of the headset.
 - 5 Press and hold down the on/off key on the headset for about 5 seconds until the indicator light flashes blue and green alternately.
 - 6 In your phone: Search for and add a new device.
 - 7 The passcode is 0000.
 - 8 The indicator light flashes blue for 2 seconds when successfully paired.
-  The headset turns off if you do not pair it with the phone within 10 minutes.

Adjusting the volume

To adjust speaker or music volume

- During a call, or when listening to music or the FM radio, swipe your finger along the volume touch area.

Calling

To make a call

- Dial the number using the phone keys. The call is automatically activated in the headset.

To end a call

- Press the call key briefly.

To make a call using voice commands

- Press the call key briefly, wait for a beep and then say the command.

To answer a call

- A beep indicates an incoming call. Press the call key briefly.

To reject a call

- Press and hold down the call key until you hear a beep.

To re-dial a number

- Double-click the call key.

To answer a second call

- Press the call key. The ongoing call is put on hold.

To switch between two calls

- Press and hold down the call key until you hear a beep.

Calling using voice commands

Voice commands can be useful when you are using the headset. For more information on voice commands, and if your phone supports it, see the phone User guide.

Transferring sound

To transfer the sound from the headset to the phone



- See the phone User guide.

To transfer the sound from the phone to the headset

- During a call on the phone, press the call key.

Listening to music



To listen to music

- 1 Press  to start the media player in your phone.
- 2 To start and pause the music, press  on the headset.

To move between tracks

- When you listen to music, press  or .

To move within a track

- Press and hold  or  key until you reach the desired position.

Listening to the Radio

- 1 Make sure your headset has a connection to the phone.
- 2 Start the radio in your phone.

To search for channels manually

- Press and hold  or  until you reach the desired position.

To select a preset radio station

- Press  or .

Resetting headset

Reset the headset if it behaves unexpectedly.

Resetting the headset removes all information about paired devices other than the phone it was shipped with.

To reset the headset

- 1 Make sure the headset is turned off.
- 2 Press and hold down the on/off key until the indicator light flashes blue and green alternately.
- 3 Simultaneously press and hold down the on/off key and the call key until the headset turns off.

Battery

A battery that has been infrequently used, or a new one, could have reduced capacity. You may need to recharge it a number of times.

When the battery level is low, you hear a low beep. If you do not charge the headset, it automatically turns off after 10 minutes.

Battery status

Battery colour	Description
One red light	The battery needs charging soon
Three green flashes	The battery is half full
Four green flashes	The battery is fully charged

To check the battery status

- Press the power key briefly. The number of green light indicators shows how full the battery is.

Troubleshooting

Redial does not work

- Make sure the call list in the phone is not empty
- Make sure your phone or other device supports the Bluetooth handsfree profile

I cannot answer a second call

- Make sure your phone supports the Bluetooth handsfree profile.

Voice commands do not work

- Make sure the voice commands are enabled and recorded in your phone before you start using them.
- Make sure your phone supports the Bluetooth headset profile.

The music is not played in the headset

- Make sure your phone or other device is paired with the headset. You may have to restart the media player and select to use the headset.

The radio does not play in the headset

- Make sure the MH100 is connected to the phone.
- If you have paired the MH100 with a phone other than the Aino, this phone might not support the FM reception in the MH100.

The headset is automatically turned off

- The battery level is too low. You hear a beep approximately 10 minutes before the headset turns off. Charge the battery.
- The headset turns off if you do not pair it with the phone within 10 minutes.

Unexpected behaviour

- Reset the headset.

No connection to the phone

Make sure the headset is charged and within range of the phone. We recommend a maximum distance of 10 metres (33 feet) with no solid objects in between. Check or reset the Bluetooth settings in the phone. Try to pair the headset again.

- 💡 It is not possible to use the headset during charging.

Go to [cross reference error](#) for more information on Bluetooth and pairing.

Troubleshooting

Some problems can be fixed using Update Service. Using Update Service on a regular basis will optimise the phone's performance. See *Updating your phone* on page 45.

Some problems will require you to call your network operator.

For more support go to www.sonyericsson.com/support.

Common questions

Where can I find the regulatory information such as my IMEI number if I cannot turn on my phone?



I have problems with memory capacity or the phone is working slowly

Restart your phone every day to free memory or do a **Master reset**.

Master reset

If you select **Reset settings**, the changes that you have made to settings will be deleted.

If you select **Reset all**, your settings and content, such as contacts, messages, pictures, sounds and downloaded games, will be deleted. You may also lose content that was in the phone at purchase.

To reset the phone

- 1 Select **Menu > Settings > General > Master reset**.
- 2 Select an option.
- 3 Follow the instructions that appear.

I cannot charge the phone or battery capacity is low

The charger is not properly connected or the battery connection is poor. Remove the battery and clean the connectors.

The battery is worn out and needs to be replaced. See *Charging the battery* on page 7.

No battery icon appears when I start charging the phone

It may take a few minutes before the battery icon appears on the screen.

The screen turns black. What do I do?

- If the screen turns black, touch somewhere on the screen to activate the screen.

Some menu options appear in grey

A service is not activated. Contact your network operator.

I cannot use Internet-based services

Your subscription does not include data capability. Settings are missing or incorrect.

You can download settings using the **Settings download** or from www.sonyericsson.com/support.

To download settings

- 1 Select **Menu > Settings > User help > Settings download**.
 - 2 Follow the instructions that appear.
-  Contact your network operator or service provider for more information.

I cannot send messages from my phone

To send messages, you need to set a service centre number. The number is supplied by your service provider and is usually saved on the SIM card. If the number to your service centre is not saved on your SIM card, you must enter the number yourself.

To send most picture messages, you must set an MMS profile and the address of your message server. If no MMS profile or message server exists, you can receive all the settings automatically from your network operator, download settings using the Basic setup or at www.sonyericsson.com/support.

To enter a service centre number

- 1 Select **Menu > Settings > Connectivity > Message settings > Text message** and scroll to **Service centre**. The number is shown if it is saved on the SIM card.
- 2 If there is no number shown, select **Edit**.
- 3 Scroll to **New service centre** and select **Add**.
- 4 Enter the number, including the international “+” sign and country code.
- 5 Select **Save**.

To select an MMS profile

- 1 Select **Menu > Settings > Connectivity > Message settings > Multim. message**.
- 2 Select an existing profile or create a new one.

To set the message server address

- 1 Select **Menu > Settings > Connectivity > Message settings > Multim. message**.
- 2 Scroll to a profile and select **Options > Edit**.
- 3 Scroll to **Message server** and select **Edit**.
- 4 Enter the address and select **OK > Save**.

The phone does not ring or rings too softly

Make sure that **Silent mode** has not been set to **On**. See *To turn off the ringtone* on page 63.

Check the ringtone volume. See *To set the ringtone volume* on page 63.

Check the profile. See *To select a profile* on page 62.

Check the divert call options. See *To divert calls* on page 21.

The phone cannot be detected by other devices using Bluetooth wireless technology

You have not turned the Bluetooth function on. Make sure that the visibility is set to **Show phone**. See *To turn on the Bluetooth function* on page 43.

I cannot synchronise or transfer content between my phone and the computer, when using a USB cable.

The software or the USB drivers have not been properly installed. Go to www.sonyericsson.com/support to read Feature guides which contain detailed installation instructions and troubleshooting sections.

Error messages

Insert SIM

There is no SIM card in your phone or you may have inserted it incorrectly.

See *To insert the SIM card* on page 4.

The SIM card connectors need cleaning. If the card is damaged, contact your network operator.

Insert correct SIM card

Your phone is set to work only with certain SIM cards. Check if you are using the correct operator SIM card.

Incorrect PIN/Incorrect PIN2

You have entered your PIN or PIN2 incorrectly.

Enter the correct PIN or PIN2 and select **OK**.

PIN blocked/PIN2 blocked

You have entered your PIN or PIN2 code incorrectly three times in a row.

To unblock, see *SIM protection* on page 65.

Codes do not match

Codes that you have entered do not match. When you want to change a security code, for example your PIN, you have to confirm the new code. See *SIM protection* on page 65.

No netw. coverage

- Your phone is in flight mode. See *Flight mode* on page 60.
- Your phone is not receiving any network signal, or the received signal is too weak. Contact your network operator and make sure that the network has coverage where you are.
- The SIM card is not working properly. Insert your SIM card in another phone. If this works, it is probably your phone that is causing the problem. Please contact the nearest Sony Ericsson service location.

Emergency calls only

You are within range of a network, but you are not allowed to use it. However, in an emergency, some network operators allow you to call the international emergency number 112. See *Emergency calls* on page 17.

PUK blocked. Contact operator.

You have entered your personal unblocking key code (PUK) incorrectly 10 times in a row.

Sony Ericsson Aino U10i/U10a/U10

This User guide is published by Sony Ericsson Mobile Communications AB or its local affiliated company, without any warranty. Improvements and changes to this User guide necessitated by typographical errors, inaccuracies of current information, or improvements to programs and/or equipment, may be made by Sony Ericsson Mobile Communications AB at any time and without notice. Such changes will, however, be incorporated into new editions of this User guide. All rights reserved.

©Sony Ericsson Mobile Communications AB, 2009

Publication number: xxxx-xxxx.1

Your mobile phone has the capability to download, store and forward additional content, e.g. ringtones. The use of such content may be restricted or prohibited by rights of third parties, including but not limited to restriction under applicable copyright laws. You, and not Sony Ericsson, are entirely responsible for additional content that you download to or forward from your mobile phone. Prior to your use of any additional content, please verify that your intended use is properly licensed or is otherwise authorized. Sony Ericsson does not guarantee the accuracy, integrity or quality of any additional content or any other third party content. Under no circumstances will Sony Ericsson be liable in any way for your improper use of additional content or other third party content.

Smart-Fit Rendering is a trademark or a registered trademark of ACCESS Co., Ltd.

Bluetooth is a trademark or a registered trademark of Bluetooth SIG Inc. and any use of such mark by Sony Ericsson is under license.

The Liquid Identity logo, PlayNow, SensMe and TrackID are trademarks or registered trademarks of Sony Ericsson Mobile Communications AB.

TrackID™ is powered by Gracenote Mobile MusicID™. Gracenote and Gracenote Mobile MusicID are trademarks or registered trademarks of Gracenote, Inc.

Sony is a trademark or registered trademark of Sony Corporation.

Media Go is a trademark or registered trademark of Sony Media Software and Services.

microSD is a trademark or a registered trademark of SanDisk Corporation.

PictBridge is a trademark or registered trademark of Canon Kabushiki Kaisha Corporation.

Wi-Fi is a trademark or a registered trademark of the Wi-Fi Alliance.

DLNA is a trademark or registered trademark of the Digital Living Network Alliance.

Google Maps™ is a trademark or registered trademark of Google, Inc.

PLAYSTATION is a trademark or registered trademark of Sony Computer Entertainment, Inc.

Wisepilot is a trademark of Appello Systems AB and its products are the property of Appello Systems AB and are protected against unauthorized use by trademark laws.

SyncML is a trademark or registered trademark of Open Mobile Alliance LTD.

Facebook is a trademark or registered trademark of Facebook, Inc.

Ericsson is a trademark or registered trademark of Telefonaktiebolaget LM Ericsson.

Mac is a trademark of Apple Inc., registered in the U.S. and other countries.

Adobe Photoshop Album Starter Edition is a trademark or registered trademark of Adobe Systems Incorporated in the United States and/or other countries.

Microsoft, Windows, Outlook, Windows Vista, Windows Server and ActiveSync are registered trademarks or trademarks of Microsoft Corporation in the United States and/or other countries.

This product is protected by certain intellectual property rights of Microsoft. Use or distribution of such technology outside of this product is prohibited without a license from Microsoft.

Content owners use Windows Media digital rights management technology (WMDRM) to protect their intellectual property, including copyrights. This device uses WMDRM software to access WMDRM-protected content. If the WMDRM software fails to protect the content, content owners may ask Microsoft to revoke the software's ability to use WMDRM to play or copy protected content. Revocation does not affect unprotected content. When you download licenses for protected content, you agree that Microsoft may include a revocation list with the licenses. Content owners may require you to upgrade WMDRM to access their content. If you decline an upgrade, you will not be able to access content that requires the upgrade.

This product is licensed under the MPEG-4 visual and AVC patent portfolio licenses for the personal and non-commercial use of a consumer for (i) encoding video in compliance with the MPEG-4 visual standard ("MPEG-4 video") or the AVC standard ("AVC video") and/or (ii) decoding MPEG-4 or AVC video that was encoded by a consumer engaged in a personal and non-commercial activity and/or was obtained from a video provider licensed by MPEG LA to provide MPEG-4 and/or AVC video. No license is granted or shall be implied for any other use. Additional information including that relating to promotional, internal and commercial uses and licensing may be obtained from MPEG LA, L.L.C. See <http://www.mpegla.com>. MPEG Layer-3 audio decoding technology licensed from Fraunhofer IIS and Thomson.

Java, JavaScript and Java-based trademarks and logos are trademarks or registered trademarks of Sun Microsystems, Inc. in the U.S. and other countries.

End-user license agreement for Sun Java Platform, Micro Edition.

1. Restrictions: Software is confidential copyrighted information of Sun and title to all copies is retained by Sun and/or its licensors. Customer shall not modify, decompile, disassemble, decrypt, extract, or otherwise reverse engineer Software. Software may not be leased, assigned, or sublicensed, in whole or in part.

2. Export Regulations: This product, including any software or technical data contained in or accompanying the product, may be subject to import and export regulations of the European Union, the United States and other countries. The user and any possessor of the product agrees to comply strictly with all such regulations and acknowledges that it is their responsibility to obtain any required licenses to export, re-export, or import this product. Without limiting the foregoing, and as an example, the user and any possessor of the product: (1) must not knowingly export or re-export Products to destinations identified pursuant to Articles in Chapter II of European Council Regulation (EC) 1334/2000; (2), must comply with U.S. government Export Administration Regulations ("EAR", 15 C.F.R. §§ 730-774, <http://www.bis.doc.gov/>) administered by Department of Commerce, Bureau of Industry and Security; and (3) must comply with economic sanctions regulations (30 C.F.R. §§ 500 et. seq., <http://www.treas.gov/offices/enforcement/ofac/>) administered by the U.S. Department of Treasury, Office of Foreign Assets Control. The user and any possessor of the product may not transport or deliver the product, its accessories or separate software to any country, region, entity or person prohibited by these regulations.

Restricted Rights: Use, duplication or disclosure by the United States government is subject to the restrictions as set forth in the Rights in Technical Data and Computer Software Clauses in DFARS 252.227-7013(c) (1) (ii) and FAR 52.227-19(c) (2) as applicable.

Other product and company names mentioned herein may be the trademarks of their respective owners.

Any rights not expressly granted herein are reserved.

All illustrations are for illustration only and may not accurately depict the actual phone.

Index

A		
activity menu	12	
alarms	60	
answering service	20	
Antivirus	64	
applications	64	
appointments	61	
assembly	4	
audio book	37	
auto rotate	63	
B		
backing up and restoring	44	
battery		
capacity	6	
charging	7	
inserting	4	
blog	30, 31	
Bluetooth	30	
Bluetooth™ wireless technology	43	
bookmarks	50	
business card	20	
C		
calendar	61	
call divert	21	
call list	17	
call numbers in message	46	
call time	23	
caller-specific ringtones	19	
calls		
accepting	22	
answering and rejecting	16	
emergency	17	
international	16	
making and receiving	16	
putting on hold	22	
recording	40	
video	17	
camera	24	
printing	31	
clear bass	36	
clear stereo	36	
clip	31	
clips	30	
conference calls	22	
Connected home	54	
contacts		
adding phone contacts	18	
default contacts	18	
groups	20	
Smart search	18	
conversations	47	
costs	6	
D		
date	62	
DLNA™	54	
download	52	
download		
settings	72	
downloading music	38	
E		
editing photos	29	
email	47	
emergency numbers	17	
equaliser	36	
F		
face detection	24	
file	52	
file manager	41	
flight mode	60	
G		
games	64	
geo tagging	29	
Google Maps™	56	
GPS	56	
groups	20	
H		
handsfree	21, 35	
hiding number	23	
I		
imaging	24	
IMEI number	66	
internet	52	
Internet		
bookmarks	50	
screen orientation	63	
security and certificates	52	
settings	71	
K		
keys	5, 67	
L		
language	13	
location services	56	
lock		
SIM card	65	
M		
master reset	71	
media browser	9	
Media Go™	42	
media transfer	42	
memory	12	
memory card	12	
memory status	19	
menu overview	10	
message	30	
messages		
email	47	
picture	46	
text	46	
voice	47	
microphone	16	
MMS	30	
<i>MMS See picture messages</i>		
model name	6	
music feed	52, 53	
music player	34, 35	
my numbers	22	
my phone number	6	
N		
navigating menus	11	
notes	61	
O		
online		
music	38	
video clips	38	

P	
pan and zoom	
web pages	51
PC Companion	41
PC Suite	59
phone	
turning on	5
phone memory	6, 12
phone name	43
photo	30, 31
photo feed	52
photos	30
feeds	53
geo tagging	29
printing	31
tags	29
picture	31
picture messages	46
pictures	30
PIN	6, 65
playlists	36
PlayNow™	38
podcast	52, 53
podcasts	53
power saving	44
profiles	62
protection	
phone	65
PUK	65
push email	49
Q	
Quick text input	14
R	
radio	38
recording	
listening to	40
Remote Play	55
restricted dialling	23
ringtones	63
setting	63
roaming	6
<i>RSS feeds - see web feeds</i>	
S	
screen icons	8
screen orientation	63
search	
on web pages	51
selection keys	11
send	30, 31
SensMe™	37
setting	
ringtones	63
settings	
download	72
Internet	71
shake control	35
share	30
shortcuts	11
web browser	50
SIM card	
copying to/from	19
inserting	4
lock and unblocking	65
<i>SMS See text messages</i>	
<i>SOS See emergency numbers</i>	
sound recorder	40
speed dialling	20
standby	6
notes	62
still camera	24
streaming	38
synchronising	59
T	
tagging photos	30
tasks	62
text messages	46
theme	63
time	62, 63
time zone	63
touch	4, 8, 9
Tracker	57
TrackID™	38
training	57
transfer	52
transfer method	
Bluetooth™ wireless technology	43
USB cable	41
transferring	
music	42
photos	42
sound	44
turning on/off	
Bluetooth™ function	43
phone lock	65
SIM lock protection	65
U	
Updating phone software	45
USB cable	41
V	
video	30, 31
video camera	24, 27
video feed	52
video player	32
video ringtones	63
voice control	21
voice messages	47
voicemail	20
volume	
ear speaker	16
ringtone	63
W	
web	52
web album	30, 31
web feeds	52
web pages history	51
web site	31
Wi-Fi™	54