

SONY[®]

DVD Handycam
TECHNOLOGY
HANDBOOK



CAMCORDERS: AN INTRODUCTION

Sony led the way in video camcorders. The first consumer cassette camcorder was developed by Sony. And in 1985, Sony's compact, lightweight 8mm Handycam® camcorders expanded the world of home video by making memories easy to shoot, play, and share anytime, anywhere.

Sony also led the way in digital technology. Sony CD and MD recording raised the standard of excellence in music reproduction. And Sony DV Handycam models adopted digital video for high-quality recording and multi-generation editing.

Now, Sony takes the next step in digital video: DVD Handycam® camcorders. They use DVD discs as their digital recording medium -- so movies can be shot on disc, stored on disc, edited in the camcorder, even uploaded to a PC for creative editing and easy sharing.

DVD offers significant advantages over cassette tape. Discs allow instant access and rapid scene search without fast-forward or rewind. They record video, audio, even still images. They're more compact and durable as a storage and playback medium.

Best of all, DVD recordings can be played back on PCs, DVD players, even PlayStation® 2 video game consoles -- for instant compatibility with over 100 million playback devices around the globe.

Sony DVD Handycam camcorders are new and exciting. This handbook explains basic DVD technology, highlights DVD Handycam camcorder features, answers common questions, and helps you understand and appreciate the exciting possibilities of this next step in camcorder evolution.

TABLE OF CONTENTS

CAMCORDERS: AN INTRODUCTION	3
DVD: A BRIEF HISTORY	5
DVD MEDIA TECHNOLOGY	6
DVD VIDEO RECORDING APPLICATIONS	10
THE DVD HANDYCAM CONCEPT	12
DVD HANDYCAM RECORD MODES AND MEDIA	14
DVD HANDYCAM STILL-IMAGE RECORDING	15
DVD HANDYCAM EDITING	16
FAQ (FREQUENTLY ASKED QUESTIONS)	18
GLOSSARY	20

DVD: A BRIEF HISTORY

The DVD format was introduced in 1996. Today, DVD is accepted worldwide, in use for a broad range of applications -- and its next major impact will be felt in the home video recording market.

The development of DVD started 12 years ago. Inspired by the success of the CD (Digital Audio Compact Disc) format for music and data recording, manufacturers began working toward the goal of a new disc format that would hold two or more hours of high-quality video recording.

In 1994, two standards were proposed: "MMCD," from Sony and Philips, and "SD," from Toshiba and Pioneer. At the end of 1995, an agreement was reached on a common standard. At this point the DVD Consortium was formed and DVD was ready for marketing. Its first applications were for prerecorded movies and computer software (DVD-ROM). Recording standards soon followed; the DVD-R Book and DVD-RAM Book standards were defined in 1997.

In 1999, the DVD-RW Book defined a 4.7 GB rewritable disc format using a short-wavelength red semiconductor laser. Currently, standardization efforts are underway to define a next-generation optical disc system using blue laser technology.

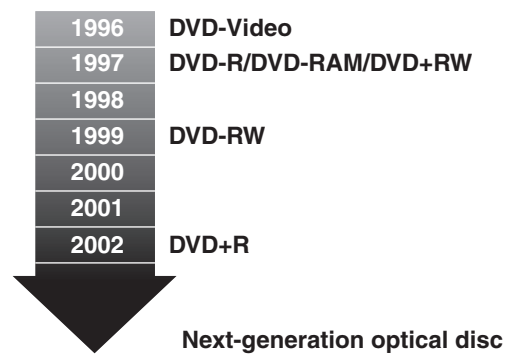

DVD Advantages

1

DVD is more compact

Because DVD discs are more compact than videocassettes, they take up less space inside the camcorder and are easier to carry, shelf and archive.

2

DVD is more durable

Videocassette recording requires contact between videotape and recording head. In the DVD system, the optical laser pickup does not touch the disc itself, so there is far less wear during recording and playback.

3

DVD provides random access

Videotapes must be wound and rewound on their reels, which takes time and creates wear. DVD discs never require rewinding -- and the search process is virtually instantaneous.

4

DVD recordings can't be erased

Videotapes can be erased within a VCR or by exposure to strong magnets. With DVD, there is no danger that contents may be accidentally erased.

DVD MEDIA TECHNOLOGY

Although a 12cm (4-3/4") DVD is the same size as a standard CD, its high-density format allows more than 7 times more data to be recorded on a single disc.

The Basic Structure of a DVD

DVD consists of a dual-layered disc 12cm (4-3/4") or 8cm (3-1/8") in diameter. Each layer has a thickness of 0.6mm (1/32").

Various kinds of DVD suit the needs of various applications, such as DVD-ROM (for playback only), DVD-R (for one-time recording), and DVD-RW (for rewritable recording).

● Structure of DVD-ROM

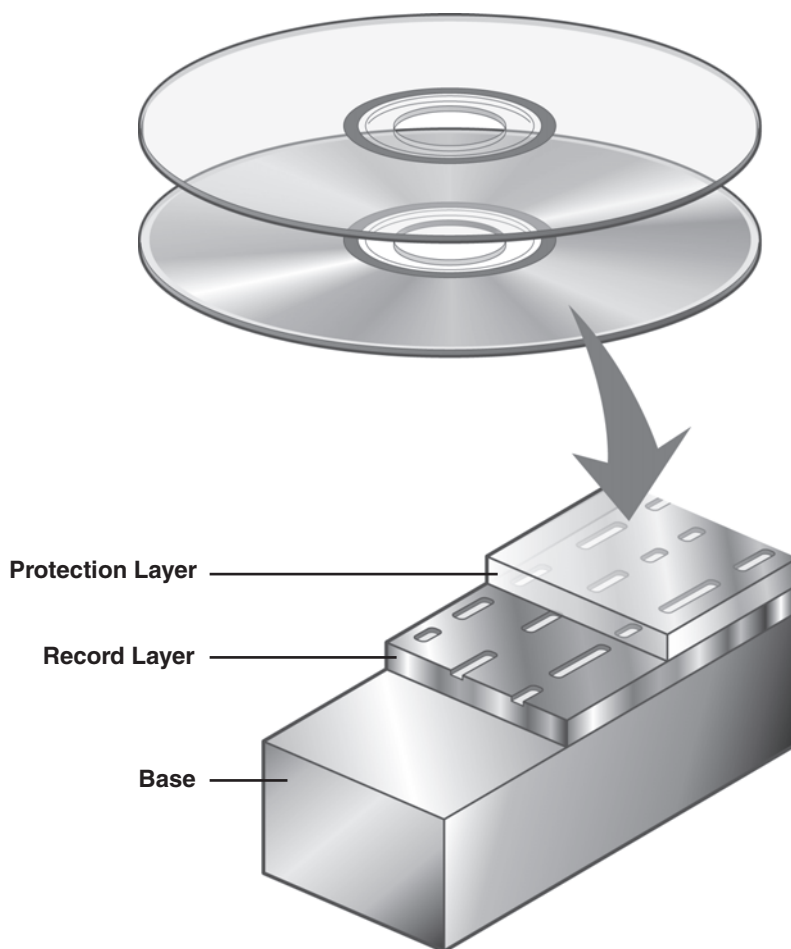

DVD-ROM for Playback Only

DVD-ROM discs are for commercial prerecorded movies, computer software programs, etc. Data is stored in the form of microscopic “pits” in the record layer of the disc. These pits are scanned by a laser and then “read” as minute reflections. These minute changes in reflection

are converted to signals for further processing. There are four different DVD configurations: single-sided discs with one or two recordable layers, and double-sided discs with one or two recordable layers.

●Record Layer of DVD-ROM

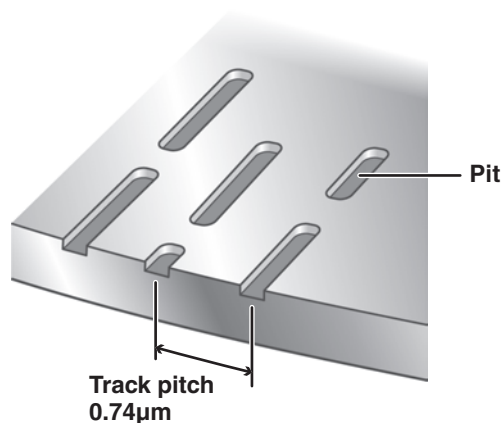

DVD-R for Recording Once

DVD-R discs are for recording only once. Since data recorded to disc cannot be erased, DVD-R is a good choice for data that requires long-term storage. Unlike commercially recorded DVD-ROM discs, DVD-R discs are recorded by a process of chemical change within the surface of the disc. After a DVD-R disc is recorded, data

is read by the optical pickup in a manner similar to the process of reading a DVD-ROM disc; this similarity makes DVD-R recordings compatible with DVD playback units. Recorded (or “written”) areas of a disc are called “grooves”; unrecorded (or “unwritten”) area is called “land.”

●Record Layer of DVD-R

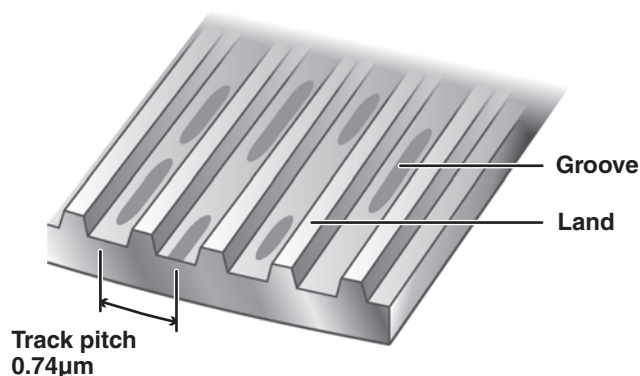

DVD MEDIA TECHNOLOGY

DVD-RW for Repeatable Recording

DVD-RW discs allow repeated recording, erasing, and re-recording of data. Data is rewritable approximately 1,000 times. This capability makes DVD-RW widely used in applications that require data editing and future updating. The recording and playback process is basically similar to the process of DVD-R recording.

In the case of DVD-RW, however, the chemical change that takes place within the surface of the disc during recording is reversible, allowing data to be erased and re-recorded. DVD-RW recordings are also compatible with most DVD players.

●Record Layer of DVD-RW

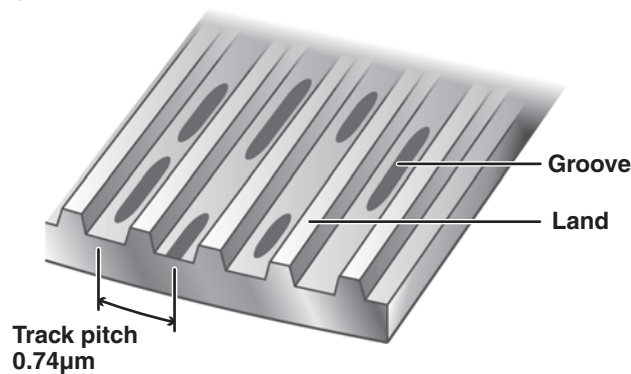

DVD Handycam camcorders use both DVD-R and DVD-RW discs. Discs are 8cm (3-1/8") in diameter; they can be single-sided with one recordable layer, or double-sided with one recordable layer per side.

Other DVD Formats

In addition to DVD-ROM, DVD-R and DVD-RW, the following DVD standards also are currently being marketed.

DVD-RAM	A rewritable media allowing up to 100,000 reliable rewriting operations. It cannot be played back on standard DVD players; only players supporting DVD-RAM can be used.
DVD+R	A once-only recording media similar in capability to DVD-R.
DVD+RW	A rewritable media similar in capability to DVD-RW.

DVD Capacity

DVD-ROM, DVD-R and DVD-RW discs 12cm (4-3/4") in size, which all share the same "one layer, one side" structure, have a storage capacity of 4.7 GB -- approximately 7 times larger than the capacity of a CD disc the same size. DVD Handycam camcorders use smaller DVD-R or DVD-RW discs 8cm (3-1/8") in size.

These smaller discs, single-sided with one recordable layer per side, have storage capacity of 1.4 GB. Small double-sided discs with one recordable layer per side are also available for DVD Handycam camcorder recording; these discs have a storage capacity of 2.8 GB -- enough to hold approximately two hours of video recording.

12cm (4-3/4")-diameter disc

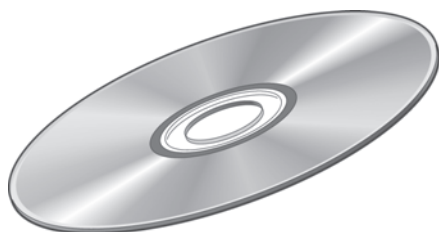

4.7GB

8cm (3-1/8")-diameter disc



1.4GB

About Lasers and Lenses

DVD recording uses a short-wavelength red semiconductor laser. The wavelength of this laser is 650nm (nanometers). The NA (numerical aperture) of the object lens used for optical pickup is 0.6. This combination yields a small-diameter "spotlight" and high-density recording capacity. By comparison, CD recording uses a semiconductor laser with a wavelength of 780nm and a NA of 0.45.

● Comparison of CD-ROM and DVD-ROM

CD-ROM

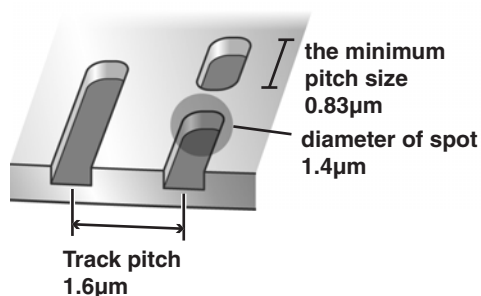

DVD-ROM

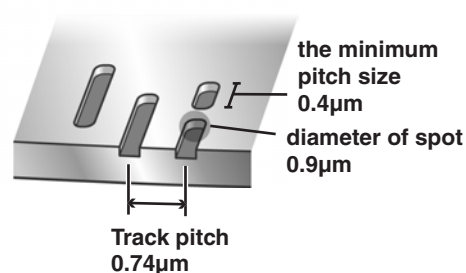

DVD VIDEO RECORDING APPLICATIONS

There are two video recording applications for DVD discs: DVD-Video, offering maximum compatibility, and DVD-VR (Video Recording), for simple in-camera editing.

What is an Application Standard?

An application standard, such as DVD-Video or DVD-VR, is not the same as a physical standard, such as DVD-ROM, DVD-R, or DVD-RW. A physical standard refers to the disc itself; application standards refer to the recording process, and determine the recording method to be used for various purposes. For the purpose of recording video with maximum flexibility for playback compatibility, the DVD-Video application standard is used. For recording video with limited playback compatibility but additional in-camera editing, the DVD-VR (Video Recording) application standard is used.

About Each Application Standard

DVD-Video

DVD-Video was first developed for commercial DVD movies. DVD-Video creates recordings that cannot be edited in the camcorder. It allows up to 2 hours of moving images and sound. MPEG 2 coding is used for video; Dolby AC-3 coding is used for sound. DVD-Video recordings can be played back on virtually all DVD players.

DVD-VR

DVD-VR modified the concept of DVD-Video, allowing user-friendly editing functions for consumer recording. DVD-VR recordings can be played back on a limited number of DVD players that support the DVD-VR application standard.

●How physical standards compare to application standards

Physical standard	DVD-R	DVD-RW	
Application standard	DVD-Video		DVD-VR
feature	Although DVD-R can only be written once, it can be played back on many models of DVD player.	DVD-RW is rewritable for further recording and can be initialized for re-use, even after finalizing. However, not all models of DVD player can play DVD-RW.	
	DVD recorded in the DVD-Video standard can be played back on many models of DVD player.	DVD recorded in the DVD-VR standard can be edited.	

 : Can be played back on a DVD player.

Video Coding Format

DVD Handycam camcorder movies recorded by the DVD-Video application standard use MPEG 2 coding to fit more data on a disc. Widely employed in communication and broadcasting, MPEG 2 offers excellent image quality and flexible data handling. Within the MPEG 2 standard, DVD-Video recordings adopt MP@ML (Main Profile at Main Level) -- a profile that provides advanced functions, at a level that maintains high-quality images.

DVD Handycam camcorder recordings also use

VBR (Variable Bit Rate) coding. Bit rate defines the amount of data that flows in a given period of time. High bit rates yield better images, but require an increased amount of data; low bit rates require less data, but at the expense of image quality. By varying the bit rate depending upon the visual content of each video scene, DVD-Video recording can maintain excellent image quality while minimizing the amount of data that must be recorded -- and maximizing the recording capacity of a single disc.

Audio Coding Format

For audio, DVD Handycam camcorders adopt the Dolby AC-3 (2-channel) format. This format provides an ideal balance between audio quality and data requirements -- and is also suitable for a wide range of channel configurations, including monaural, 2-channel stereo, and 5.1-channel surround sound applications.

Another audio recording format, Linear PCM (Pulse Code Modulation), offers excellent audio quality without data compression. Although this audio format is suitable for prerecorded music, music videos, etc., its data requirements are higher.

About Initializing and Finalizing

"Initializing" means preparing a disc for recording. DVD-R discs do not require initializing. DVD-RW discs must be initialized, and this is done inside the DVD Handycam camcorder. Each time you insert a new or uninitialized DVD-RW disc, you will see a prompt that asks if you wish to initialize your disc. Initializing erases all previously recorded information. If your disc has already been initialized and partially recorded, it does not require initializing for subsequent recording sessions.

"Finalizing" DVD-R and DVD-RW discs means preparing them for playback. In order to play back your recordings on DVD players or computers with DVD-ROM drives, you need to finalize your disc. But even without finalizing, you can always view the contents of your recording using the DVD Handycam camcorder as your playback device -- viewing scenes on your camcorder's screen, or on your TV screen by connecting direct A/V output on your camcorder to video audio inputs on your TV.

Once a DVD-R disc has been finalized, no further recording is possible. DVD-RW discs, however, can be "unfinalized" and initialized again for further recording.

THE DVD HANDYCAM CONCEPT

Sony DVD Handycam camcorders bring unique and exciting advantages to the world of video recording.

The Concept

1

Compatibility with DVD Players

DVD-R and DVD-RW discs recorded by DVD Handycam camcorders in the DVD-Video application can be easily played back on most existing DVD players -- making DVD-Video discs compatible with most decks, computers and PlayStation 2 consoles worldwide.

2

Fast Search & Access

DVD offers many advantages over videocassette tape systems, including fast search and access to scenes by selecting thumbnail images. DVD Handycam camcorders automatically create thumbnail images during the finalization process; these images can be used for instant access to the scene you want. Thumbnail images are viewable whether you use your camcorder playback or play back scenes on your DVD player or PC computer.

3

Editing with a PC

Data recorded on DVD Handycam camcorders can be easily played back and editing on a PC. Video can be transferred from camcorder to PC by inserting the DVD-R or DVD-RW disc into the disc drive of a PC, or by connecting the camcorder to the PC via USB. USB 2.0 provides high-speed data transfer. Both DVD-Video and DVD-VR discs can be edited.

4

Movies and Still Images

With DVD, a single media can record both movies and still images. Still images are recorded on the disc as JPEG files. DVD Handycam camcorders allow you to play an automatic, continuous "slide show" of your still images on your TV screen. Both movies and still images can be recorded on the same DVD-R or DVD-RW disc.

5

High-Density, High-Quality Data

By adopting MPEG 2 and VBR (Variable Bit Rate) data compression, DVD Handycam recording maintains superb picture quality while permitting high-capacity recording on the disc.

6

High Fidelity Audio

By using Dolby AC-3 (2-channel) audio recording, DVD Handycam camcorders provide high-quality stereo sound for lifelike realism.

About Thumbnail Display

DVD Handycam recorded screens are capable of displaying recorded contents in the form of thumbnail images -- six images per screen. Thumbnails can show both movies scenes and still images. These thumbnail images are automatically created when you finalize your disc. Unlike systems that only identify movies or images by time and date, thumbnail images are more useful because they give you a visual record of what each scene or still

image shows.

Before finalizing, you can always use your DVD Handycam camcorder as your playback device using the LCD screen or by connecting the supplied AV cable to your TV. After finalizing a recorded disc, you can view dated thumbnails on your TV screen using a standard DVD player or on your PC computer screen. You can also display the title of your finalized DVD recording.

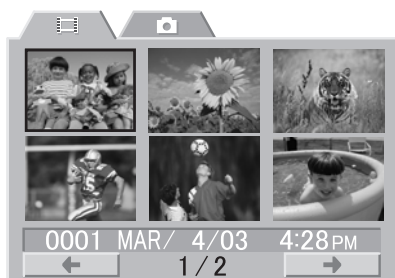

thumbnails on DVD Handycam

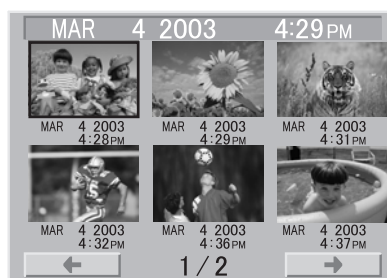

thumbnails on DVD players

Playback Compatibility

The DVD Handycam camcorder recording system is based on international DVD standards, so DVD Handycam recordings can be played back on a vast universe of playback devices -- including most DVD players, personal computers with DVD drives, and PlayStation 2 video game consoles.

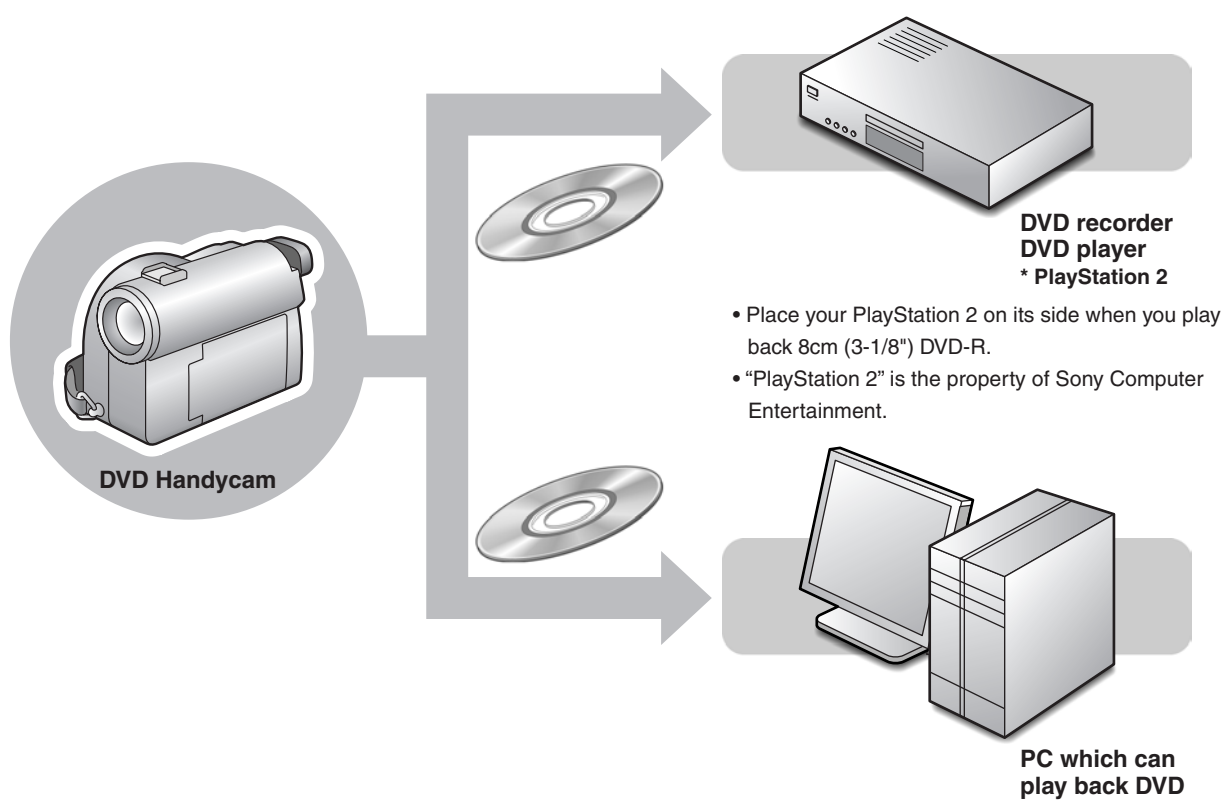

Note on DVD Player and PC Playback

DVD-R/RW discs recorded by Sony DVD Handycam camcorders are designed to be compatible with and may be played back on most home DVD players, computer DVD drives, and PlayStation 2 video game consoles sold in the U.S.*

* Playback on all home DVD players, computer DVD drives, and PlayStation 2 consoles cannot be guaranteed. Some players, drives, and video game consoles lack the ability to read due to the optical reflection standards of DVD-R/RW discs and/or due to encoding incompatibilities. Refer to the specifications of your playback equipment for additional compatibility information.

DVD HANDYCAM RECORD MODES AND MEDIA

In addition to DVD-Video and DVD-VR (Video Recording) applications, you can also select from three recording modes to determine the image quality and recording time your application demands.

Three Record Modes

Choose among three modes: HQ for the highest quality images, SP to balance image quality and recording time, or LP for the longest recording time.

Record mode	The standard of the record time	Feature
HQ	Approximately 20 minutes for single-side/20 minutes × 2 for double-side	High image quality
SP	Approximately 30 minutes for single-side/30 minutes × 2 for double-side	Standard image quality
LP	Approximately 60 minutes for single-side/60 minutes × 2 for double-side	Longer recording time

* The above-mentioned record time is a reference value. Recording time may change depending on the recording situation.

Recommended DVD Media

For use in DVD Handycam camcorders, Sony recommends "DMR30" 8cm (3-1/8") DVD-R discs or "DMW30" DVD-RW discs. Sony "DMR60DS" and "DMW60DS" 8cm (3-1/8") double-sided discs may also be used.

● Sony 8cm (3-1/8") DVD-R



● Sony 8cm (3-1/8") DVD-RW



DVD HANDYCAM STILL-IMAGE RECORDING

DVD Handycam camcorders can also record still images on DVD -- allowing them to function as both movie camcorders and digital still-image cameras.

JPEG Images

Still images are recorded as digital files in JPEG form. At the time you finalize your DVD-R or DVD-RW disc, you can create a slide show for playback viewing on your TV using a DVD player or PlayStation 2 game console. And of course it is also possible to copy JPEG files to your PC.

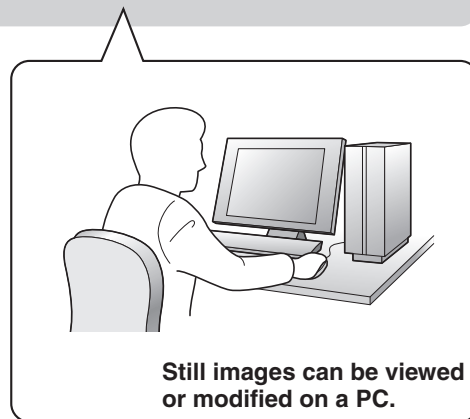
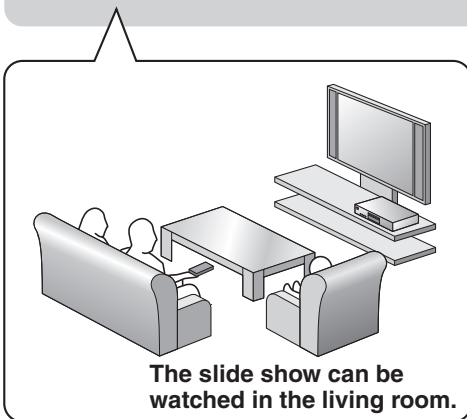

Playback from Your Camcorder

Using your DVD Handycam camcorder, you can view a slide show of still images without finalizing your DVD disc. In order to use a DVD player for on-screen playback, you must first finalize your disc.

DVD HANDYCAM EDITING

DVD Handycam camcorder recordings provide simple in-camera editing functions that help you organize your scenes and still images when you shoot in DVD-VR mode.

Playlist Editing

Playlists can be created on DVD-RW discs recorded by your DVD Handycam camcorder in DVD-VR mode. By creating a Playlist, you can rearrange your recorded scenes, cut and divide scenes, and create the playback order that tells your story in the most effective way.

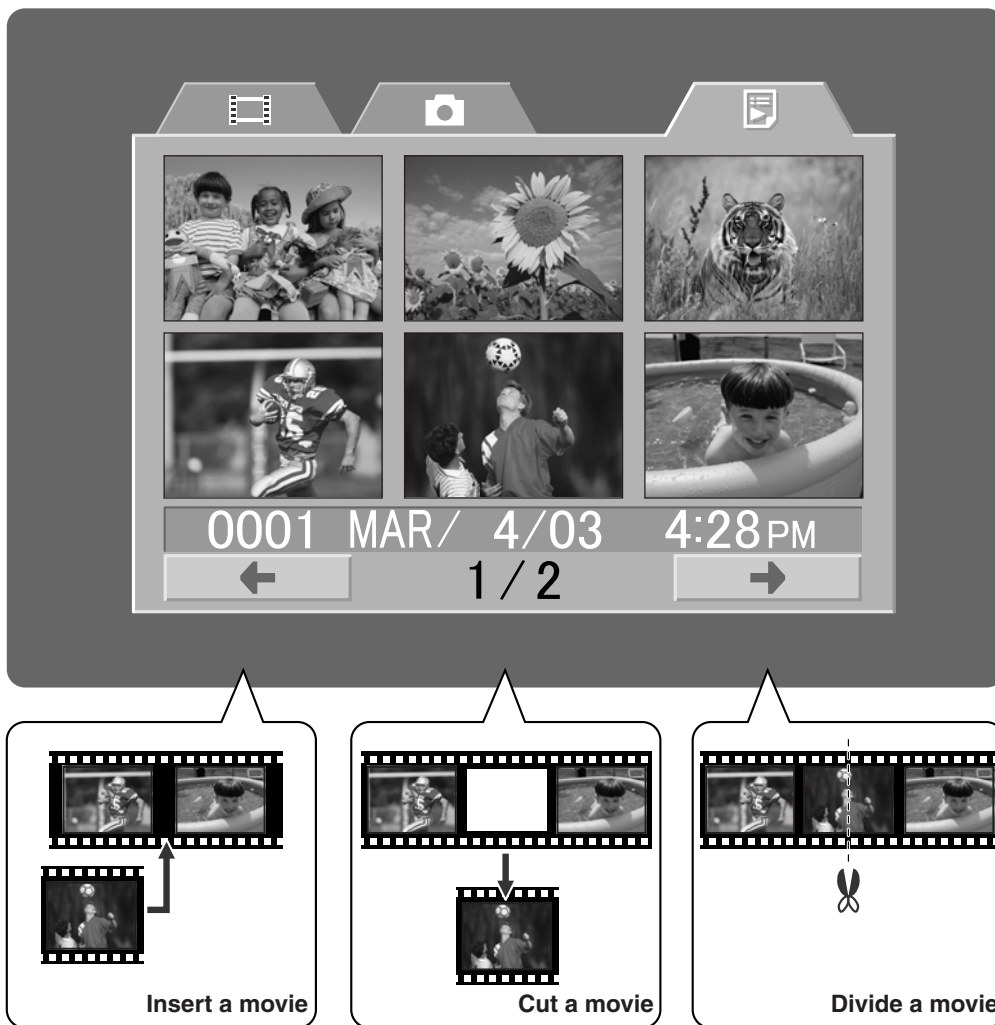

Transferring Recordings to a PC

There are two ways to use your PC to view and edit DVD Handycam camcorder movies and still images. After you finalize your DVD-R or DVD-RW disc, you can insert the disc directly into the DVD drive of a PC for editing and playback.

If your disc is not finalized, you must use the supplied ImageMixer software whether you insert the disc into your PC's DVD drive or transmit data between a DVD Handycam camcorder and a PC via USB-2 connector. Once recordings have been transferred to your PC, you can perform creative movie editing and also duplicate your discs.

▶ Creating an Original DVD

After recorded images have been transferred to a PC, they can be edited using supplied ImageMixer software (vers. 1.5 for Sony). You can then create a new original DVD containing your edited recording.



▶ Duplicating a DVD

Connecting a DVD Handycam camcorder to a PC allows you to create a new DVD disc even if your PC has no DVD burner.

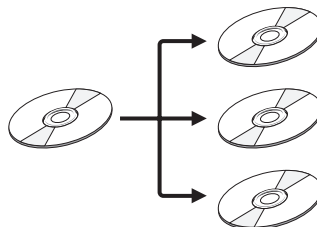

▶ High-Speed USB Transmission

DVD Handycam camcorders adopt USB 2.0 as a connection interface. At maximum transmission rate of 22.16 Mbps*, you can transfer a large amount of data quickly and smoothly.

* Your PC must also support USB 2.0 (high-speed USB) in order to transfer at a rate of 22.16 Mbps. Maximum transmission speed will vary depending on the PC model you are using.

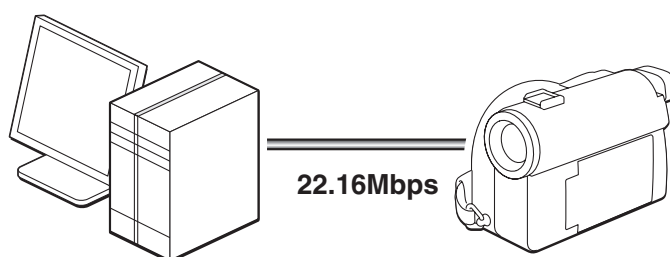
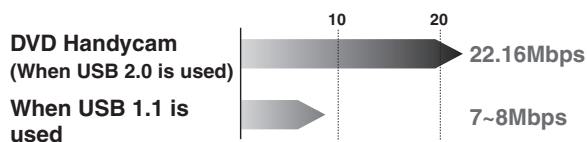

FAQ (FREQUENTLY ASKED QUESTIONS)

Questions about Recording

Q How long will my DVD Handycam record?

A Up to two hours on a double-sided DVD disc.

Q What recording modes can I use?

A You can use either LP (long play), SP (standard play), or HQ (high quality) recording mode. You can also switch modes during operation.

Q Can multi-session recording be performed -- that is, recording additional information after a disc has been finalized?

A No.

Questions about Media

Q What media is recommended?

A Sony 3-1/8" (8cm) DVD-R discs (DMR30, DMR60) or Sony 3-1/8" DVD-RW (DMW30, DMW60) discs are recommended.

Q Can a 3-1/8" DVD-RAM disc be recorded or played back on a DVD Handycam camcorder?

A No.

Q Can I use DVD+R or DVD+RW discs in my DVD Handycam camcorder?

A No. The DVD Handycam system uses only DVD-R or DVD-RW discs.

Q Is a cartridge or caddy needed for DVD Handycam camcorders?

A No. Discs are loaded directly into your camcorder.

Q Can a 4-3/4" (12cm) adaptor be used?

A Most DVD players and drives will easily accommodate 8cm (3-1/8") media. A 12cm adaptor is not needed.

Questions about Initializing Discs

Q Is initializing (formatting) required before I record on a DVD disc?

A DVD-R discs do not need to be initialized. DVD-RW discs must be initialized. This process is done inside the camcorder; each time you load a new DVD-RW disc, you will see a menu prompt that asks if you want to initialize your disc.

Q Can a recorded DVD-R disc be initialized and used again?

A No. DVD-R is a record-once format; once recorded, the discs cannot be initialized and re-used.

Q If a disc is initialized, does free-memory recording capacity decrease?

A Capacity may decrease a small amount, but there is very little reduction in recording time.

Questions about Finalizing Discs

Q What is finalizing?

A Finalizing is the process that allows a DVD disc to be played back on other equipment.

Q Can a PC finalize my disc?

A No; it must be finalized by the DVD Handycam camcorder.

Q If a finalized disc is copied on a PC using DVD ImageMixer software, is the copy also finalized?

A Yes, automatically.

Q Can discs which have not been finalized be copied on a PC by ImageMixer software?

A Yes, but movie scenes and still images are copied one by one. To copy the entire disc, the disc must be finalized.

Q Can a finalized disc be unfinalized?

A A DVD-RW disc recorded by a DVD Handycam camcorder in DVD-Video mode can be unfinalized and recorded again. DVD-RW discs recorded in DVD-VR (Video Recording) mode cannot be unfinalized, although additional data can be recorded after finalizing. A DVD-R disc recorded and finalized cannot be re-recorded.

Q How long does finalizing take?

A That depends on the amount of recorded data the disc contains. In general, finalizing a disc will take between two and ten minutes; discs with more recorded material take a shorter time to finalize.

Q What happens if battery power runs out during the finalizing process?

A The finalizing process will pause. When power is restored and your DVD Handycam is turned on, finalizing will begin again automatically from the scene where pausing took place. It is strongly recommended that an AC Adaptor be used when you finalize data.

Questions about Playback

Q Can my DVD Handycam camcorder play back commercially recorded DVD movies or videos?

A No. Sony DVD Handycam models are designed for DVD-R (record once) and DVD-RW (record and rewrite) discs. They can't be used to play back commercial DVD recordings.

Q Can Sony DVD Handycam camcorders play back commercially recorded 8cm DVD-RAM discs?

A No.

Q Can a disc recorded on a DVD Handycam camcorder be played back on DVD players in any region?

A Yes. Discs recorded on DVD Handycam camcorders have region-code "All" -- so they can be played back on DVD players anywhere in the world.

Q Can a DVD disc recorded on a PC be played back on a DVD Handycam camcorder?

A Yes, if the disc is recorded in DVD-Video or DVD-VR format and the sound is recorded in Dolby AC-3.

Q Will a disc recorded and finalized on other devices display its menus if played back on a DVD Handycam camcorder?

A No. Other circumstances may also affect the display of main menus and other menus.

Questions about Sound

Q Is it possible that a disc recorded on another device will play back on my DVD Handycam camcorder with picture but not sound?

A Yes; DVD Handycam can only play back Dolby AC-3 (2-channel) sound. Sound recorded on DVD disc in other audio formats (MPEG Layer2, Linear PCM, etc.) will not be heard.

Q Can a disc recorded in 5-1 channel surround sound be played back on a DVD Handycam camcorder?

A Yes, but sound will be heard in 2-channel stereo.

Questions about Editing

Q Can I edit my DVD recordings?

A Yes, in two ways:

- 1 Simple in-camera editing can be performed in your DVD Handycam camcorder when you record in DVD-VR (Video Recording) mode. In-camera editing lets you cut scenes you don't want and change the order of scenes you've recorded.
- 2 More complex editing can be done in your PC using supplied Sony DVD ImageMixer software (vers. 1.5 for Sony).

Q What is a "scene"?

A A scene refers to the portion of your DVD recording shot in a single take -- from the moment you start recording to the moment you stop recording.

Q If I delete an unwanted scene after recording in DVD-VR mode, does the recording capacity on my disc increase?

A Yes, it does -- but when a short scene or a still image is deleted, the capacity may not increase.

Q Can I use my DVD Handycam camcorder as a DVD burner?

A Yes. Using supplied ImageMixer software on your PC, you can connect your DVD Handycam camcorder to your PC using USB 2.0 and record your movies or still images to a DVD disc.

Questions about Software

Q Is any software supplied with my DVD Handycam camcorder?

A Yes -- ImageMixer (vers. 1.5 for Sony) software is supplied.

Q What do I need to run my software?

A A PC with Windows ME, Windows 2000 Professional, or Windows XP Home Edition/Professional.

Q What does ImageMixer do?

A It lets you do lots of things -- and they're all easy:

- Copy movie scenes or still images onto another disc.
- Transmit a movie or still image between a PC and your DVD Handycam camcorder.
- Edit DVD movies or still images on your PC.
- Review your recordings on an unfinalized disc.

Q Can I use ImageMixer software that comes with a Hi8, miniDV or Digital Handycam camcorder?

A No: the ImageMixer software provided with Sony tape-based camcorders can't copy or edit your DVD movies.

Q Can both DVD ImageMixer and tape-based ImageMixer software be simultaneously installed on the same PC?

A Yes.

Q Can I use other software to edit my DVD movies?

A DVD Handycam recordings can be edited by software that is capable of taking in and editing MPEG 2 files (data converted into MPEG form by ImageMixer software). Even in MPEG form, however, you may not be able to edit data depending on the type or version of software used.

Q Can my DVD ImageMixer software edit movies or images recorded with Digital Video or MICROMV camcorders?

A No.

Questions about Thumbnail Images

Q What is a thumbnail?

A A small image shown as one of a multiple set of images on a camcorder or PC screen.

Q What do thumbnails show?

A When you view them on your DVD Handycam camcorder screen before finalizing your disc, they show the first image of a movie scene or a still image. After you finalize a disc, thumbnail images also display date and time of recording.

Q How are thumbnails created?

A Each time you start recording, the first image at the beginning of your scene automatically becomes a thumbnail.

Q Are visual index screens different in DVD-Video and DVD-VR (Video Recording) modes?

A Yes; in addition to thumbnails of movie scenes and still images, the visual index screen for DVD-RW discs can also show playlists of scenes or still images in an order you determine.

Questions about PC Transfer

Q Can images be transferred from a DVD Handycam camcorder to a PC whether or not a disc has been finalized?

A Yes, via USB using ImageMixer (vers. 1.5 for Sony) software.

Q Can a disc also be copied by USB 1.1 (full-speed USB)?

A Although the disc can be copied, it takes more time than by using USB 2.0 (high-speed USB).

Q Is it possible to transfer the contents of a disc recorded in DVD-VR (Video Recording) mode to a PC, then copy this material to a DVD-R disc in DVD-Video mode for playback on other devices?

A Yes. However, you need to save your recorded data in DVD-VR mode onto your PC hard drive -- then convert it into DVD-Video mode to record it on a new DVD.

Questions about Still Images

Q Can I record still images on a DVD Handycam camcorder?

A Yes -- thousands of images on a single DVD disc.

Q Before finalizing a disc, can still images be viewed?

A Still images can be viewed on your DVD Handycam screen before you finalize your disc. Using ImageMixer software and USB connector, you can also transfer still images to your PC before your disc is finalized. If you want to view images on a TV screen using a DVD Player, you must finalize data by selecting "Create" on the slide show display when you finalize your disc.

Q Can I change the display time of a still-image slide show?

A No. Once setup time is fixed, it cannot be changed.

Q Can still images be rotated?

A No.

GLOSSARY

❑ Bit Rate

The amount (measured in “bits”) of data that flows in a specified period of time. For video recording and playback, which requires a large amount of data, bit rate is expressed in Mbps (“megabits per second”). In general, a higher bit rate results in higher-quality picture and sound. Bit rate can also be constant or variable.

❑ Coding

In a digital video or audio signal, coding (or encoding) refers to the process of converting data from one form to another -- for example, into a compressed form so more data can be recorded and stored on a DVD disc. During playback, the compressed data is decoded to its original form.

❑ Constant Bit Rate

Constant Bit Rate (CBR) means that all scenes are converted at the same rate; its purpose is to simplify the coding and decoding process.

❑ Dolby AC-3

The audio system used in DVD Handycam recordings. In the Dolby AC-3 system, audio can be recorded in 2-channel stereo, monophonic, or 5.1 channel surround sound (using six speakers for front left/right, center, rear left/right, and subwoofer). Audio compression only takes place in the frequency range beyond human hearing.

❑ DVD Applications

DVD is a multipurpose medium used for storing moving and still images, audio and data. Its official name is “Digital Versatile Disc.” There are various applications for DVD discs, including high-capacity storage of computer software and data. DVD video applications include DVD-Video, used for high-quality commercial recordings, and DVD-VR (Video Recording), used for personal video recordings that can be re-written (recorded more than once) and edited.

❑ DVD Capacity

CD-sized DVD discs (4-3/4" or 12cm in diameter) can have one or two sides, and each side can contain one or two recordable layers. For a single-sided disc, dual-layer recording allows for up to 8.5 GB of data. For a double-sided disc, single-layer recording holds up to 9.4 GB. A double-sided disc with two recording layers can hold up to 17 GB of data. DVD Handycam camcorder use smaller 3-1/8" (8cm) discs. A double-sided DVD Handycam disc has one recording layer per side and holds up to 2.8 GB of data; it allows up to 2 hours of recording.

❑ DVD Formats

DVD discs for video recording exist in various formats or standards. DVD-ROM is a playback-only format used for commercial movies. DVD-R is a format that can be recorded only once. DVD-RW can be recorded, edited and re-written (re-recorded). DVD-RAM, DVD+R and DVD+RW are alternate recordable formats not compatible with Sony DVD Handycam camcorders, which use only discs that conform to DVD-R and DVD-RW standards.

❑ DVD-Video

The application for DVD recordings that do not require editing. DVD-Video allows up to 2 hours of high quality moving images and sound on a single disc, using MPEG 2 coding for movies and Dolby AC-3 (Dolby Digital 2-Channel) or linear PCM recording for sound. DVD-Video is an optical disc format that also allows for special playback features such as multiple screen ratios, captions, language options, and simultaneous multi-angle viewing of a scene.

❑ DVD-VR

The application for which Sony DVD Handycam camcorders are designed. DVD-VR (or DVD Video Recording) provides added in-camera capabilities such as re-recording, editing, playlist display, etc.

❑ Finalizing

Finalizing a disc enables its recorded contents to be played back on other equipment. Once finalized, DVD-R and DVD-RW discs are read as though they were commercial recorded DVD movies -- allowing them to be played back on most DVD players. A finalized disc can no longer be re-recorded, but DVD-RW discs can be “unfinalized” to return them to recordable state.

❑ Groove/Land

On a DVD disc, “groove” describes the spiral field where data is written to a recordable layer; “land” describes areas where data is not written. In the case of DVD-ROM, reading is carried out by an optical pickup following “pits” in the surface of the disc. In the case of DVD-R and DVD-RW, reading is carried out by an optical pickup following grooves in the surface of the disc.

❑ Initializing

Initializing a disc allows the disc to be recorded or written on. Initializing a previously recorded disc will erase all existing data on the disc. DVD-R discs do not need to be initialized. DVD-RW discs must be initialized. The DVD Handycam camcorder system provides an “initializing” prompt each time a new DVD-RW disc is inserted.

❑ Laser

The DVD Handycam recording system uses a short-wavelength red semiconductor laser device to record data. This device passes current to a semiconductor and emits a strong beam of light. Gallium arsenic is used to generate the short-wavelength red laser beam that reads digital data on a DVD disc.

❑ Linear PCM Recording

Linear PCM (Pulse Code Modulation) is an audio system that converts analog to digital signals without compression; it is used primarily in high fidelity music recording. DVD Handycam camcorders do not use Linear PCM recording.

❑ MPEG

MPEG (Moving Pictures Experts Group) is an international group that establishes industry-wide standards for digital signal compression. These standards are known as MPEG 1, MPEG 2, MPEG 4, etc.

❑ MPEG 2

MPEG 2 is a digital standard for demanding video applications. It offers high quality images with data compression that reduces the amount of data that must be processed. Rather than processing complete video frames, the MPEG 2 system processes only the differences between adjacent frames.

❑ MP@ML

The MPEG 2 standard allows various parameter setups for picture formats and coding modes. MP@ML (Main Profile at Main Level) is the parameter setup adopted for DVD-Video and DVD-VR (Video Recording) applications. "Profile" refers to the combination of functions provided; "Level" refers to the level of resolution and frame rate.

❑ Numerical Aperture

Numerical Aperture (NA) value determines the performance of an object lens; the larger the value, the more data can be written at any one time.

❑ Optical Pickup

This device combines a short wavelength semiconductor red laser, a pair of 45-degree mirrors, an object lens and a photodiode. In the DVD Handycam system, light emitted from the laser is bent at a 45-degree angle, passes through the object lens, reflects off the surface of the DVD disc, is concentrated by the object lens and detected by the photodiode.

❑ Object Lens

This lens performs two tasks: first, focusing the laser onto the disc surface; second, collecting the reflected laser light and concentrating it on the photodiode detector. The performance of the object lens largely depends on the value of its numerical aperture (NA).

❑ Pit

Pits describe the microscopic hollows within the surface of a DVD-ROM or CD-ROM disc. Data is read in a spiral motion and is determined by the length and number of pits that occur. The discs used by DVD Handycam camcorders do not have pits; instead, their data is carried by changes in reflection on the disc's surface.

❑ Playlist

The function that arranges movie scenes and still images on a DVD disc. Playlists can be set up for editing and playback purposes; recorded scenes and still images are not changed by being put in playlist order.

❑ Track

A data-recording field in the shape of a spiral or concentric circle. CD and DVD tracks have a spiral structure; floppy disc and hard disc tracks are concentric. The distance between adjacent tracks is called "track pitch."

❑ Variable Bit Rate

Variable Bit Rate (VBR) changes its data conversion process depending on the amount of movement (or "dynamics") in a given scene; its purpose is to reduce data requirements to a minimum while maintaining high image quality.

❑ Visual Index

A DVD Handycam function that displays movie scenes and still images as "thumbnail" images on a multi-image screen, making it easy to find a specific scene or image for playback.

• Manufactured under license from Dolby Laboratories.
 "Dolby" and the double-D symbol are trademarks of Dolby Laboratories.
 • Microsoft and Windows are trademarks or registered trademarks of Microsoft Corporation in the United States and / or other countries.
 • PlayStation is registered trademarks of Sony Computer Entertainment Inc.
 • All other product names mentioned herein may be the trademarks or registered trademarks of their respective companies. Furthermore, "TM" and "®" are not mentioned in each case in this manual.

DVD Handycam
TECHNOLOGY
HANDBOOK

