

- 2 Press ENTER of the control button.

The Clock display appears.

- 3 Select the display mode of date (Y/M/D, M/D/Y, or D/M/Y) by pressing ▲ or ▼ of the control button.

- 4 Set the date and time.

- 1) Select an item to be set by pressing ◀ or ▶ of the control button.
- 2) Set the value by pressing ▲ or ▼ of the control button.

- 5 When all settings are finished, select OK by pressing ▶ of the control button.

- 6 Press ENTER of the control button.

The date and time are set, and the Setup display is retrieved.

To interrupt setting the date and time

Select CANCEL in step 5, and press ENTER of the control button.

Setting the Record Resolution (RESOLUTION)

Set the appropriate record resolution for the size to be printed.

For the appropriate resolution for each print size, see "Recommended resolutions" on page 34.

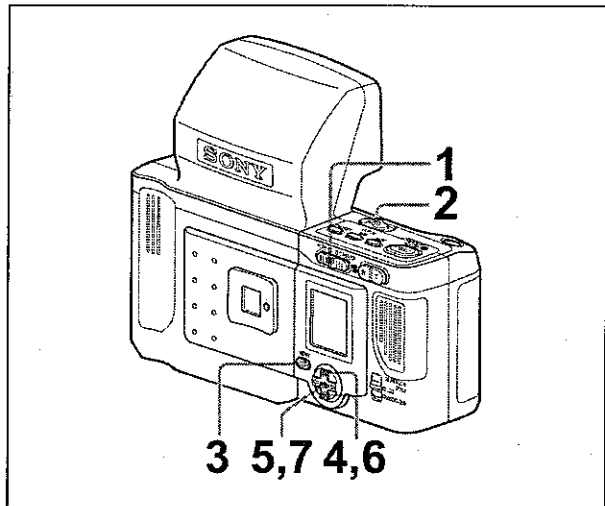

- 1 Set the PLAY/CAMERA switch to CAMERA.

- 2 Set the POWER switch to ON.

- 3 Press the MENU button twice.

The Menu display appears.

- 4 Select RESOLUTION by pressing ▲ or ▼ of the control button.

- 5 Press ENTER of the control button.

The Record Resolution display appears.

- 6 Select the resolution by pressing ▲ or ▼ of the control button.

HIGH: 2288 × 1712

MID: 1280 × 960

STD: 832 × 624

- 7 Press ENTER of the control button.

The Menu display is retrieved.

Recommended resolutions

Size No.	Print size		Recommended resolution		
	Height mm (inches)	Width mm (inches)	HIGH	MID	STD
1	151 (6)	101.6 (4)	●	▲	×
2	120 (4 ^{3/4})	90 (3 ^{5/8})	●	▲	×
21 (L) ¹⁾	108 (4 ^{3/8})	81 (3 ^{1/4})	●	▲	×
3	95 (3 ^{3/4})	70 (2 ^{7/8})	●	▲	×
4, 17 (D2)	80 (3 ^{1/4})	60 (2 ^{3/8})	○	●	▲
5	70 (2 ^{7/8})	53 (2 ^{1/8})	○	●	▲
6	70 (2 ^{7/8})	50 (2)	○	●	▲
7, 18 (D4)	60 (2 ^{3/8})	40 (1 ^{5/8})	○	●	▲
8	54 (2 ^{1/4})	54 (2 ^{1/4})	○	●	▲
9	50 (2)	48.5 (1 ^{15/16})	○	●	▲
10, 19 (D6), 21 (S) ¹⁾ , 22 (L) ²⁾	47 (1 ^{7/8})	37 (1 ^{1/2})	○	○	▲
11, 20 (D4/D8)	45 (1 ^{13/16})	35 (1 ^{7/16})	○	○	●
12	45 (1 ^{13/16})	45 (1 ^{13/16})	○	●	▲
13, 22 (S) ²⁾	43 (1 ^{3/4})	33 (1 ^{2/16})	○	○	●
14	38 (1 ^{1/2})	32 (1 ^{2/16})	○	○	●
15	34 (1 ^{3/8})	28 (1 ^{1/8})	○	○	●
16	23 (2 ^{9/32})	23 (2 ^{9/32})	○	○	●

- 1) 21(S): Size of a smaller image of 21. Special-1
 21(L): Size of a larger image of 21. Special-1
 2) 22(S): Size of a smaller image of 22. Special-2
 22(L): Size of a larger image of 22. Special-2

- : The best combination of the resolution and print size. Use this resolution if the print size is known.
- : The resolution is too high for the print size. It is recommended to use the resolution indicated by ○, for storing the maximum number of pictures in memory.
- ▲: The resolution is a little lower for the print size, but the print quality can be adjusted to an acceptable level.
- ×: The resolution is too low for the print size. This is not recommended.

Setting the Zoom Range (ZOOM)

The zoom range is set to 1.3× (f = 15.6 to 19.8 mm) at the factory. This range can be changed to 2.6× (f = 7.50 to 19.8 mm) with the procedures below.

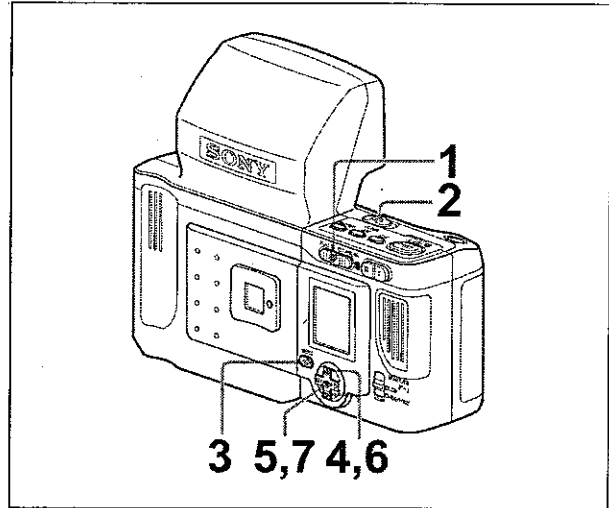

- 1 Set the PLAY/CAMERA switch to CAMERA.
- 2 Set the POWER switch to ON.
- 3 Press the MENU button twice.
The Menu display appears.
- 4 Select ZOOM by pressing ▲ or ▼ of the control button.
- 5 Press ENTER of the control button.
The Zoom Range display appears.
- 6 Select f = 7.50 to 19.8 mm by pressing ▲ of the control button.
- 7 Press ENTER of the control button.

The Menu display is retrieved.

Note

When the built-in flash is used as the main lighting, it is recommended to use the factory-set zoom range (f = 15.6 to 19.8). If you use a zoom range of f = 7.50 to 19.8, be sure to set the zoom to within the blue zone of the zoom bar displayed on the LCD. If you shoot a subject in the orange zone, sufficient lighting may not be obtained.

Setting the Shooting Conditions

The shooting conditions are set at the factory so that you can take pictures automatically. If necessary, you can set the conditions manually.

The shooting conditions that can be controlled manually depend on the exposure control mode. The table below shows the available shooting conditions for each exposure control mode.

Exposure control mode	Flash mode (FLASH MODE)	Prelighting/prephotometry	Shutter speed (SHUTTER)	Aperture (APERTURE)	White balance (W.B.)	Exposure revise (EXPOSURE)
PROGRAM AUTO	A $\text{\textcircled{A}}$	Prelighting/prephotometry	1/30 to 1/1000	AUTO	AUTO/---/3000K to 7000K	+0.75 EV to -1.0 EV
	$\text{\textcircled{A}}$	Prelighting	1/250	AUTO	AUTO/One Push/3000K to 7000K	+0.75 EV to -1.0 EV
	$\text{\textcircled{A}}$	Prephotometry	1/2 to 1/1000	AUTO	AUTO/One Push/3000K to 7000K	+0.75 EV to -1.0 EV
APERTURE PRIORITY	A $\text{\textcircled{A}}$	Prelighting/prephotometry	1/30 to 1/1000	Manual	AUTO/---/3000K to 7000K	+0.75 EV to -1.0 EV
	$\text{\textcircled{A}}$	Prelighting	1/250	Manual	AUTO/One Push/3000K to 7000K	+0.75 EV to -1.0 EV
	$\text{\textcircled{A}}$	Prephotometry	1/2 to 1/1000	Manual	AUTO/One Push/3000K to 7000K	+0.75 EV to -1.0 EV
MANUAL EXPOSURE	M $\text{\textcircled{A}}$	No	1/2 to 1/1000	Manual	AUTO/One Push/3000K to 7000K	+0.75 EV to -1.0 EV
	M $\text{\textcircled{A}}$	No	1/2 to 1/1000	Manual	AUTO/One Push/3000K to 7000K	+0.75 EV to -1.0 EV

$\text{\textcircled{A}}$: Automatic setting

Selecting the exposure control mode (Exposure Mode)

Three exposure control modes are available: PROGRAM AUTO, APERTURE PRIORITY, and MANUAL EXPOSURE.

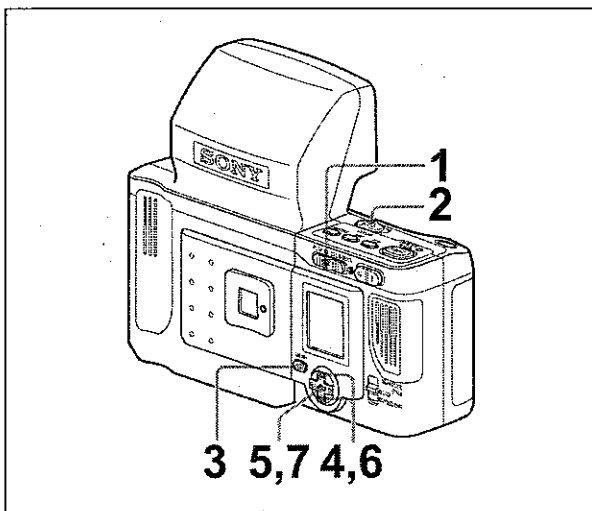

- 1 Set the PLAY/CAMERA switch to CAMERA.
- 2 Set the POWER switch to ON.

- 3 Press the MENU button twice.

The Menu display appears.

- 4 Select PROGRAM AUTO, APERTURE PRIORITY, or MANUAL EXPOSURE by pressing \blacktriangle or \blacktriangledown of the control button.

- 5 Press ENTER of the control button.

The Exposure Mode display appears.

- 6 Select PROGRAM AUTO, APERTURE PRIORITY, or MANUAL EXPOSURE by pressing \blacktriangle or \blacktriangledown of the control button.

PROGRAM AUTO: The aperture and shutter speed are adjusted automatically.

APERTURE PRIORITY: The aperture is adjusted manually, while the shutter speed is adjusted automatically.

MANUAL EXPOSURE: The aperture and shutter speed are adjusted manually.

- 7 Press ENTER of the control button.

The Menu display is retrieved.

Setting the flash mode (FLASH MODE)

When the exposure mode is set to PROGRAM AUTO or APERTURE PRIORITY, the exposure is automatically adjusted, and three flash modes are available. When the exposure control is set to MANUAL EXPOSURE, the exposure is manually adjusted, and two flash modes are available.

- 1 Set the PLAY/CAMERA switch to CAMERA.
- 2 Set the POWER switch to ON.
- 3 Press the MENU button twice.

The Menu display appears.

- 4 Select FLASH MODE by pressing ▲ or ▼ of the control button.
- 5 Press ENTER of the control button.

The Flash Mode display appears.

- 6 Select the flash mode by pressing ▲ or ▼ of the control button.

For automatic exposure control

▲: Auto flash

⚡: Forced flash

⊕: No flash

For manual exposure control

M▲: Forced flash

M⊕: No flash

- 7 Press ENTER of the control button.

The selected flash mode is set, and the Menu display is retrieved.

Making the aperture setting (APERTURE)

When the exposure mode is set to APERTURE PRIORITY or MANUAL EXPOSURE, the aperture setting can be made manually. The aperture values vary depending on the zooming position.

- 1 Set the PLAY/CAMERA switch to CAMERA.
- 2 Set the POWER switch to ON.
- 3 Press the MENU button twice.

The Menu display appears.

- 4 Select APERTURE by pressing ▲ or ▼ of the control button.

- 5 Press ENTER of the control button.

The Aperture Setting display appears.

- 6 Select an appropriate aperture value by pressing ▲ or ▼ of the control button.

- 7 Press ENTER of the control button.

The selected aperture value is set, and the Menu display is retrieved.

Selecting the shutter speed (SHUTTER)

When the exposure mode is set to MANUAL EXPOSURE, the shutter speed can be selected.

- 1 Set the PLAY/CAMERA switch to CAMERA.
- 2 Set the POWER switch to ON.
- 3 Press the MENU button twice.

The Menu display appears.

- 4 Select SHUTTER by pressing ▲ or ▼ of the control button.

- 5 Press ENTER of the control button.

The Shutter Speed display appears.

- 6 Select an appropriate shutter speed by pressing ▲ or ▼ of the control button.

- 7 Press ENTER of the control button.

The selected shutter speed is set, and the Menu display is retrieved.

Revising the exposure (EXPOSURE)

- 1 Set the PLAY/CAMERA switch to CAMERA.
- 2 Set the POWER switch to ON.
- 3 Press the MENU button twice.

The Menu display appears.

- 4 Select EXPOSURE by pressing ▲ or ▼ of the control button.

- 5 Press ENTER of the control button.

The EV Compensation display appears.

6 Select an appropriate value by pressing ▲ or ▼ of the control button.

7 Press ENTER of the control button.

The selected value is set, and the Menu display is retrieved.

To revise the exposure easily

The exposure can easily be changed by pressing ▲ or ▼ of the control button. When the button is pressed, the value displayed on the LCD changes.

Adjusting the white balance (W.B.)

1 Set the PLAY/CAMERA switch to CAMERA.

2 Set the POWER switch to ON.

3 Press the MENU button twice.

The Menu display appears.

4 Select W.B. by pressing ▲ or ▼ of the control button.

5 Press ENTER of the control button.

The White Balance display appears.

6 Select the method for adjusting the white balance by pressing ▲ or ▼ of the control button.

AUTO: The white balance is adjusted automatically.

One Push: The white balance is adjusted for the lighting conditions when this option is selected. Under the same lighting conditions as shooting a picture, display a white subject in the center frame, and select this option. Then the white balance under these lighting conditions is adjusted.

3000K to 7000K: Select the color temperature according to the lighting conditions, and the white balance is adjusted for the selected temperature.

7 Press ENTER of the control button.

The white balance is adjusted, and the Menu display is retrieved.

Canceling the modification

If you wish to cancel the setting on any setting display and return to the Menu display, press ◀ of the control button. Your setting is canceled, and the Menu display is retrieved.

Setting the Print Size to be Displayed (PRINT SIZE LIST)

The print size selectable with the SIZE button can be set in the SETUP menu. Set the sizes frequently used; then you can select the desired size easily.

At the factory, all sizes are set selectable. Set the sizes you wish to select with the SIZE button with the procedures below.

As for the printouts of the selected size, see "Printouts that Can Be Made with This System" on page 8.

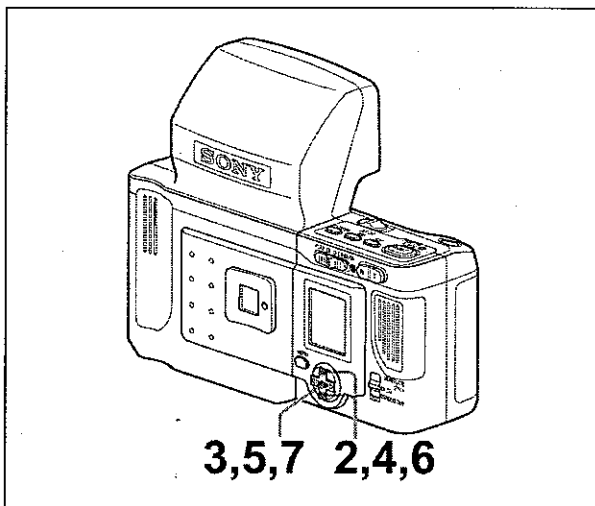

1 Display the Setup display.

For details on displaying the Setup display, see "Displaying the Setup display" on page 32.

2 Select PRINT SIZE LIST by pressing ▲ or ▼ of the control button.

3 Press ENTER of the control button.

The Print Size display appears.

4 Select the size that is not to be displayed by pressing ▲ or ▼ of the control button.

5 Press ENTER of the control button.

The display of the size selected in step 4 changes from black to gray.

Repeat steps 4 and 5 to make the display of the sizes that is not to be selected with the SIZE button gray.

The display of the size toggles between black and gray each time you press ENTER.

Note

The Guide Print-RGB and Guide Print-DLGm are always displayed on the LCD. You cannot set them not to be displayed.

6 When setting is finished, select RETURN by pressing ▲ or ▼ of the control button.

7 Press ENTER of the control button.

The Setup display is retrieved.

Setting the Frame (FRAME)

Guidelines for adjusting the size and position of the subject are helpful to decide on framing. This system offers six types of guidelines, four fixed types, one for upper and lower lines adjustable, and one for the width of two vertical lines adjustable.

Fixed types

The following four fixed types of guidelines are available.

FRAME-[1]

The dimension between the head and chin lines is 27 mm when you select the print size 10.47 × 37 mm or 11.47 × 35 mm.

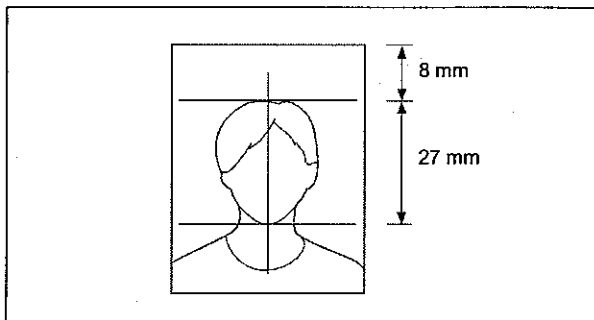

FRAME-[2]

Two chin lines are displayed. The dimension between the head and chin lines is 1 inch or 1 3/8 inch when you select the print size 8.54 × 54 mm.

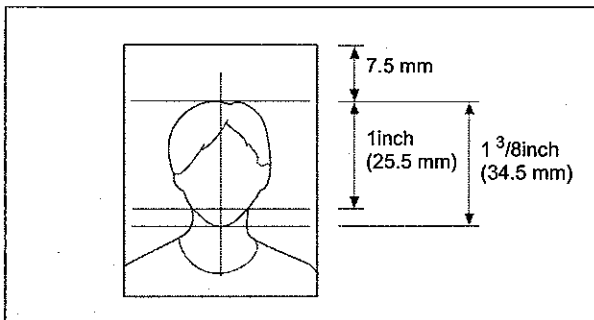

FRAME-[3]

The dimension between the head and chin lines is 28 mm when you select the print size 10.47 × 37 mm or 11.47 × 35 mm.

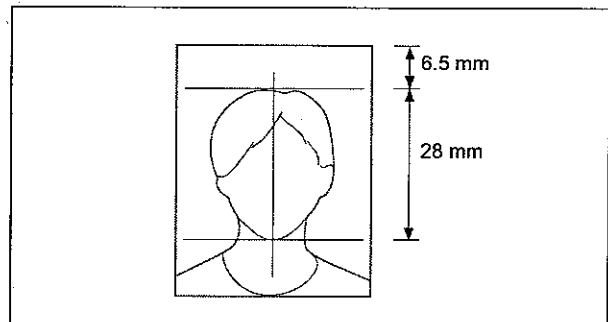

FRAME-[4]

The dimension between the head and chin lines is 22 mm when you select the print size 10.47 × 37 mm or 11.47 × 35 mm.

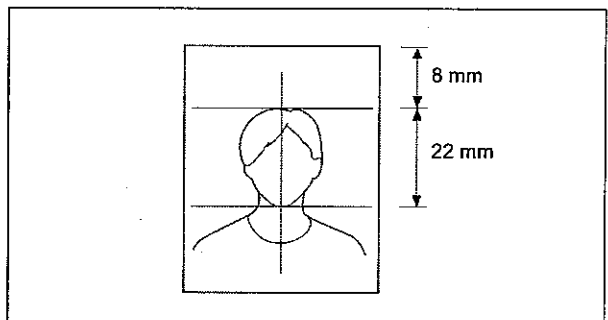

Selecting the fixed guidelines (FRAME-[1], FRAME-[2], FRAME-[3], FRAME-[4])

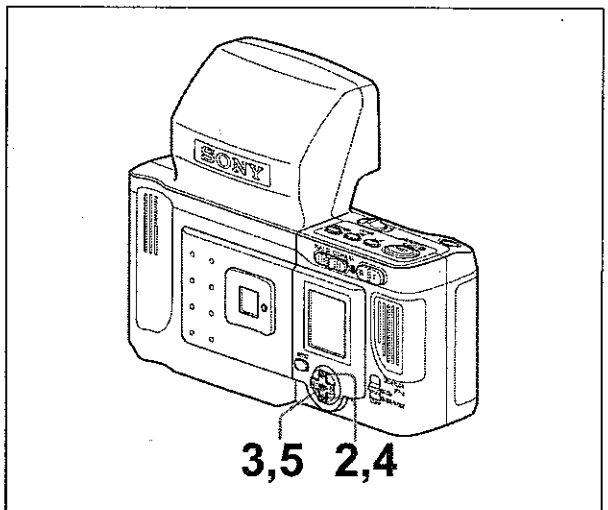

1 Display the Setup display.

For details on displaying the Setup display, see "Displaying the Setup display" on page 32.

2 Select FRAME by pressing ▲ or ▼ of the control button.

The guidelines for the selected frame appear on the LCD.

3 Press ENTER of the control button.

5 Press ENTER of the control button.

The frame select display appears.

The Setup display is retrieved.

4 Select FRAME-[1], FRAME-[2], FRAME-[3] or FRAME-[4] by pressing ▲ or ▼ of the control button.

Size of the printouts for FRAME-[1], FRAME-[2], FRAME-[3], FRAME-[4]

When you take pictures using the guidelines, the size of printouts is as shown below according to the print size selected with the SIZE button.

Tolerance: ±1 mm or 5%

Print size	FRAME-[1]				FRAME-[2]			FRAME-[3]		FRAME-[4]	
	Size No.	(a) mm (inches)	(b) mm (inches)	(c) mm (inches)	(d) mm (inches)	(c) mm (inches)	(d) mm (inches)	(e) mm (inches)	(c) mm (inches)	(d) mm (inches)	(c) mm (inches)
1	151 (6)	101.6 (4)	31.5 (1 ¹ / ₄)	79.0 (3 ¹ / ₈)	35.5 (1 ⁷ / ₁₆)	73.0 (2 ⁷ / ₈)	54.0 (2 ¹ / ₄)	27.0 (1 ¹ / ₈)	81.5 (3 ¹ / ₄)	31.5 (1 ¹ / ₄)	64.5 (2 ⁵ / ₈)
2	120 (4 ³ / ₄)	90 (3 ⁵ / ₈)	23.0 (2 ⁹ / ₃₂)	64.5 (2 ⁵ / ₈)	26.5 (1 ¹ / ₁₆)	59.5 (2 ³ / ₈)	44.0 (1 ³ / ₄)	20.0 (1 ³ / ₁₆)	66.5 (2 ⁵ / ₈)	23.0 (2 ⁹ / ₃₂)	52.5 (2 ¹ / ₈)
21 (L) ¹⁾	108 (4 ³ / ₈)	81 (3 ¹ / ₄)	17.0 (1 ¹ / ₁₆)	64.5 (2 ⁵ / ₈)	20.5 (1 ³ / ₁₆)	57.0 (2 ¹ / ₄)	44.0 (1 ³ / ₄)	14.0 (9 ¹ / ₁₆)	66.5 (2 ⁵ / ₈)	17.0 (1 ¹ / ₁₆)	52.5 (2 ¹ / ₈)
3	95 (3 ³ / ₄)	70 (2 ⁷ / ₈)	18.0 (2 ³ / ₃₂)	52.0 (2 ¹ / ₈)	20.5 (1 ³ / ₁₆)	48.0 (1 ¹⁵ / ₁₆)	35.5 (1 ⁷ / ₁₆)	15.0 (1 ⁹ / ₃₂)	53.5 (2 ¹ / ₈)	18.0 (2 ³ / ₃₂)	42.5 (1 ¹¹ / ₁₆)
4, 17 (D2)	80 (3 ¹ / ₄)	60 (2 ³ / ₈)	16.0 (2 ¹ / ₃₂)	41.5 (1 ¹¹ / ₁₆)	18.5 (3 ¹ / ₄)	38.5 (1 ⁹ / ₁₆)	28.5 (1 ¹ / ₈)	14.0 (9 ¹ / ₁₆)	43.0 (1 ³ / ₄)	16.0 (1 ⁶ / ₃₂)	34.0 (1 ³ / ₈)
5	70 (2 ⁷ / ₈)	53 (2 ¹ / ₈)	13.5 (9 ¹ / ₁₆)	37.5 (1 ¹ / ₂)	15.5 (5 ¹ / ₈)	34.5 (1 ³ / ₈)	25.5 (1 ¹ / ₁₆)	11.5 (1 ¹⁵ / ₃₂)	38.5 (1 ⁹ / ₁₆)	13.5 (9 ¹ / ₁₆)	30.5 (1 ¹ / ₄)
6	70 (2 ⁷ / ₈)	50 (2)	13.5 (9 ¹ / ₁₆)	37.5 (1 ¹ / ₂)	15.5 (5 ¹ / ₈)	34.5 (1 ³ / ₈)	25.5 (1 ¹ / ₁₆)	11.5 (1 ¹⁵ / ₃₂)	38.5 (1 ⁹ / ₁₆)	13.5 (9 ¹ / ₁₆)	30.5 (1 ¹ / ₄)
7, 18 (D4)	60 (2 ³ / ₈)	40 (1 ⁵ / ₈)	11.0 (7 ¹ / ₁₆)	33.0 (1 ⁵ / ₁₆)	12.5 (1 ¹ / ₂)	30.5 (1 ¹ / ₄)	22.5 (2 ⁹ / ₃₂)	9.5 (3 ¹ / ₈)	34.5 (1 ³ / ₈)	11.0 (7 ¹ / ₁₆)	27.0 (1 ¹ / ₈)
8	54 (2 ¹ / ₄)	54 (2 ¹ / ₄)	5.5 (7 ¹ / ₃₂)	37.5 (1 ¹ / ₂)	7.5 (5 ¹ / ₁₆)	34.5 (1 ³ / ₈)	25.5 (1 ¹ / ₁₆)	3.5 (2 ³ / ₃₂)	38.5 (1 ⁹ / ₁₆)	5.5 (7 ¹ / ₃₂)	30.5 (1 ¹ / ₄)
9	50 (2)	48.5 (1 ¹⁵ / ₁₆)	6.0 (1 ¹ / ₄)	33.0 (1 ⁵ / ₁₆)	7.5 (5 ¹ / ₁₆)	30.5 (1 ¹ / ₄)	22.5 (2 ⁹ / ₃₂)	4.5 (3 ¹ / ₁₆)	34.5 (1 ³ / ₈)	6.0 (1 ¹ / ₄)	27.0 (1 ¹ / ₈)
10, 19 (D6), 21 (S) ¹⁾ , 22 (L) ²⁾	47 (1 ⁷ / ₈)	37 (1 ¹ / ₂)	8.0 (1 ¹ / ₃₂)	27.0 (1 ¹ / ₈)	9.5 (3 ¹ / ₈)	25.0 (1)	18.5 (3 ¹ / ₄)	6.5 (9 ¹ / ₃₂)	28.0 (1 ¹ / ₈)	8.0 (1 ¹ / ₃₂)	22.0 (7 ¹ / ₈)
11, 20 (D4/D8)	45 (1 ¹³ / ₁₆)	35 (1 ⁷ / ₁₆)	8.0 (1 ¹ / ₃₂)	27.0 (1 ¹ / ₈)	9.5 (3 ¹ / ₈)	25.0 (1)	18.5 (3 ¹ / ₄)	6.5 (9 ¹ / ₃₂)	28.0 (1 ¹ / ₈)	8.0 (1 ¹ / ₃₂)	22.0 (7 ¹ / ₈)
12	45 (1 ¹³ / ₁₆)	45 (1 ¹³ / ₁₆)	3.5 (5 ¹ / ₃₂)	33.0 (1 ⁵ / ₁₆)	5.0 (7 ¹ / ₃₂)	30.5 (1 ¹ / ₄)	22.5 (2 ⁹ / ₃₂)	2.0 (3 ¹ / ₃₂)	34.5 (1 ³ / ₈)	3.5 (5 ¹ / ₃₂)	27.0 (1 ¹ / ₈)
13, 22 (S) ²⁾	43 (1 ³ / ₄)	33 (1 ⁵ / ₁₆)	8.5 (1 ¹ / ₃₂)	23.0 (2 ⁹ / ₃₂)	9.5 (3 ¹ / ₈)	21.0 (2 ⁷ / ₃₂)	15.5 (3 ¹ / ₈)	7.0 (9 ¹ / ₃₂)	23.5 (1 ⁵ / ₁₆)	8.5 (1 ¹ / ₃₂)	18.5 (3 ¹ / ₄)
14	38 (1 ¹ / ₂)	32 (1 ⁵ / ₁₆)	6.0 (1 ¹ / ₄)	23.0 (2 ⁹ / ₃₂)	7.0 (9 ¹ / ₃₂)	21.0 (2 ⁷ / ₃₂)	15.5 (3 ¹ / ₈)	4.5 (3 ¹ / ₁₆)	23.5 (1 ⁵ / ₁₆)	6.0 (1 ¹ / ₄)	18.5 (3 ¹ / ₄)
15	34 (1 ³ / ₈)	28 (1 ¹ / ₈)	5.0 (7 ¹ / ₃₂)	21.0 (2 ⁷ / ₃₂)	6.0 (1 ¹ / ₄)	19.0 (3 ¹ / ₄)	14.0 (9 ¹ / ₁₆)	4.0 (3 ¹ / ₁₆)	21.5 (7 ¹ / ₈)	5.0 (7 ¹ / ₃₂)	17.0 (1 ¹ / ₁₆)
16	23 (2 ⁹ / ₃₂)	23 (2 ⁹ / ₃₂)	2.0 (3 ¹ / ₃₂)	16.5 (2 ¹ / ₃₂)	3.0 (1 ¹ / ₈)	15.5 (3 ¹ / ₈)	11.5 (1 ⁵ / ₃₂)	1.0 (1 ¹ / ₁₆)	17.0 (1 ¹ / ₁₆)	2.0 (3 ¹ / ₃₂)	13.5 (9 ¹ / ₁₆)

- 1) 21(S): Size of a smaller image of 21. Special-1
21(L): Size of a larger image of 21. Special-1
- 2) 22(S): Size of a smaller image of 22. Special-2
22(L): Size of a larger image of 22. Special-2

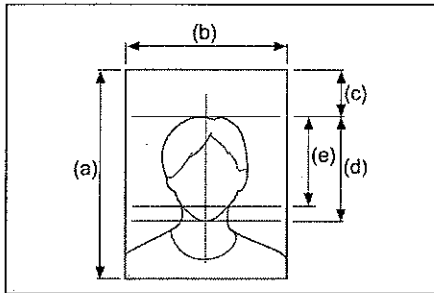

Adjusting the upper and lower guidelines (FRAME-[5])

The upper and lower guidelines of FRAME-[5] are set at the same position of FRAME-[1] at the factory. You can modify the position of the two guidelines with the procedures below.

For the size of printouts after adjusting the position, see "Size of printouts for FRAME-[5]" on page 40.

- 1 Display the Setup display.
For details on displaying the Setup display, see "Displaying the Setup display" on page 32.
- 2 Select FRAME by pressing ▲ or ▼ of the control button.
- 3 Press ENTER of the control button.

The frame select display appears.
- 4 Select FRAME-[5] by pressing ▲ or ▼ of the control button.

The guidelines of FRAME-[5] appear on the LCD.

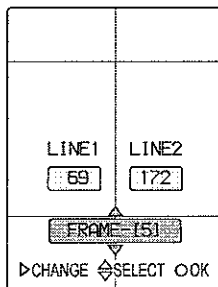

- 5 Adjust the upper and lower guideline positions.

LINE1 adjusts the upper guideline, and LINE2 adjusts the lower line.

- 1) Select LINE 1 by pressing ► of the control button.
- 2) Adjust the position of LINE1 by pressing ▲ or ▼ of the control button.
- 3) Select LINE2 by pressing ◀ or ▶ of the control button.
- 4) Adjust the position of LINE2 by pressing ▲ or ▼ of the control button.
- 5) Press ENTER of the control button.
- 6 Press ENTER of the control button.

The Setup display is retrieved.

Size of printouts for FRAME-[5]

At the factory, LINE1 is set to 69, and LINE2 is set to 172. The values for (c) and (f) are obtained by multiplying the value in F with the values of LINE1 and LINE2, as shown below.

$$(c) = \text{LINE1} \times F$$

$$(f) = \text{LINE2} \times F$$

If you select Size No.1, and the guidelines are placed at the factory setting position, the size to be printed is as follows:

$$(c) = 69 \times 0.46 = 31.7 \text{ mm}$$

$$(f) = 172 \times 0.46 = 78.1 \text{ mm}$$

Tolerance: ±1 mm or 5%

Size No.	Print size		Factory setting		F
	(a) mm (inches)	(b) mm (inches)	(c) mm (inches)	(d) mm (inches)	
1	151 (6)	101.6 (4)	31.5 (1 ¹ / ₄)	79.0 (3 ¹ / ₈)	0.46
2	120 (4 ³ / ₄)	90 (3 ⁵ / ₈)	23.0 (2 ⁹ / ₃₂)	64.5 (2 ⁵ / ₈)	0.37
21 (L) ¹⁾	108 (4 ³ / ₈)	81 (3 ¹ / ₄)	17.0 (1 ¹ / ₁₆)	64.5 (2 ⁵ / ₈)	0.32
3	95 (3 ³ / ₄)	70 (2 ⁷ / ₈)	18.0 (2 ³ / ₃₂)	52.0 (2 ¹ / ₈)	0.3
4, 17 (D2)	80 (3 ¹ / ₄)	60 (2 ³ / ₈)	16.0 (2 ¹ / ₃₂)	41.5 (1 ¹¹ / ₁₆)	0.24
5	70 (2 ⁷ / ₈)	53 (2 ¹ / ₈)	13.5 (9 ¹ / ₁₆)	37.5 (1 ¹ / ₂)	0.22
6	70 (2 ⁷ / ₈)	50 (2)	13.5 (9 ¹ / ₁₆)	37.5 (1 ¹ / ₂)	0.22
7, 18 (D4)	60 (2 ³ / ₈)	40 (1 ⁵ / ₈)	11.0 (7 ¹ / ₁₆)	33.0 (1 ⁵ / ₁₆)	0.19
8	54 (2 ¹ / ₄)	54 (2 ¹ / ₄)	5.5 (7 ¹ / ₃₂)	37.5 (1 ¹ / ₂)	0.22
9	50 (2)	48.5 (1 ¹⁵ / ₁₆)	6.0 (1 ¹ / ₄)	33.0 (1 ⁵ / ₁₆)	0.19
10, 19 (D6), 21 (S) ¹⁾ , 22 (L) ²⁾	47 (1 ⁷ / ₈)	37 (1 ¹ / ₂)	8.0 (1 ¹ / ₃₂)	27.0 (1 ¹ / ₈)	0.16

Size No.	Print size		Factory setting		F
	(a) mm (inches)	(b) mm (inches)	(c) mm (inches)	(d) mm (inches)	
11, 20 (D4/D8)	45 (1 ¹³ / ₁₆)	35 (1 ⁷ / ₁₆)	8.0 (¹¹ / ₃₂)	27.0 (1 ¹ / ₈)	0.16
12	45 (1 ¹³ / ₁₆)	45 (1 ¹³ / ₁₆)	3.5 (⁵ / ₃₂)	33.0 (1 ⁵ / ₁₆)	0.19
13, 22 (S) ²	43 (1 ³ / ₄)	33 (1 ³ / ₁₆)	8.5 (¹¹ / ₃₂)	23.0 (²⁹ / ₃₂)	0.13
14	38 (1 ¹ / ₂)	32 (1 ⁵ / ₁₆)	6.0 (¹ / ₄)	23.0 (²⁹ / ₃₂)	0.13
15	34 (1 ³ / ₈)	28 (1 ¹ / ₈)	5.0 (⁷ / ₃₂)	21.0 (²⁷ / ₃₂)	0.12
16	23 (²⁹ / ₃₂)	23 (²⁹ / ₃₂)	2.0 (³ / ₃₂)	16.5 (²¹ / ₃₂)	0.1

- 21(S): Size of a smaller image of 21. Special-1
21(L): Size of a larger image of 21. Special-1
- 22(S): Size of a smaller image of 22. Special-2
22(L): Size of a larger image of 22. Special-2

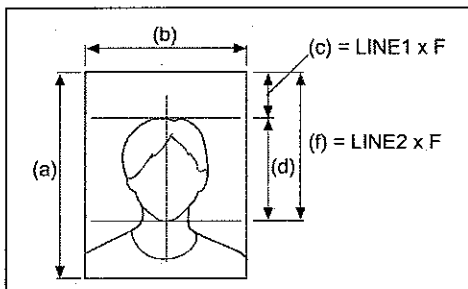

Adjusting the width of the guidelines (FRAME-[6])

- Display the Setup display.
For details on displaying the Setup display, see "Displaying the Setup display" on page 32.
- Select FRAME by pressing ▲ or ▼ of the control button.
- Press ENTER of the control button.
The frame select display appears.
- Select FRAME-[6] by pressing ▲ or ▼ of the control button.

The guidelines of FRAME-[6] appear on the LCD.

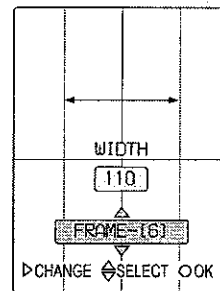

- Adjust the width of the guidelines.
 - Select WIDTH by pressing ► of the control button.
 - Adjust the width of the guidelines by pressing ▲ or ▼ of the control button.
 - Press ENTER of the control button.
- Press ENTER of the control button.

The Setup display is retrieved.

Size of printouts for FRAME-[6]

At the factory, WIDTH is set to 110. The print size is obtained by multiplying the value in G with the values of WIDTH as shown below.

$$(g) = \text{WIDTH} \times G$$

If you select the size "1" with the factory setting position, the size to be printed is as follows:

$$(g) = 110 \times 0.54 = 59.4 \text{ mm}$$

Tolerance: ±1 mm or 5%

Size No.	Print size		Factory setting	G
	(a) mm (inches)	(b) mm (inches)	(g) mm (inches)	
1	151 (6)	101.6 (4)	59.1 (²³ / ₈)	0.54
2	120 (4 ³ / ₄)	90 (3 ⁵ / ₈)	48.2 (1 ⁵ / ₁₆)	0.44
21 (L) ¹	108 (4 ³ / ₈)	81 (3 ¹ / ₄)	42 (1 ¹¹ / ₁₆)	0.38
3	95 (3 ³ / ₄)	70 (2 ⁷ / ₈)	38.9 (1 ⁹ / ₁₆)	0.35
4, 17 (D2)	80 (3 ¹ / ₄)	60 (2 ³ / ₈)	31.1 (1 ¹ / ₄)	0.28
5	70 (2 ⁷ / ₈)	53 (2 ¹ / ₈)	28 (1 ¹ / ₈)	0.25
6	70 (2 ⁷ / ₈)	50 (2)	28 (1 ¹ / ₈)	0.25
7, 18 (D4)	60 (2 ³ / ₈)	40 (1 ⁵ / ₈)	24.9 (1)	0.23

Print size			Factory setting	G
Size No.	(a) mm (inches)	(b) mm (inches)		
8	54 (2 ¹ / ₄)	54 (2 ¹ / ₄)	28 (1 ¹ / ₈)	0.25
9	50 (2)	48.5 (1 ¹⁵ / ₁₆)	24.9 (1)	0.23
10, 19 (D6), 21 (S) ¹ , 22 (L) ²	47 (1 ⁷ / ₈)	37 (1 ¹ / ₂)	20.2 (¹³ / ₁₆)	0.18
11, 20 (D4/D8)	45 (1 ¹³ / ₁₆)	35 (1 ⁷ / ₁₆)	20.2 (¹³ / ₁₆)	0.18
12	45 (1 ¹³ / ₁₆)	45 (1 ¹³ / ₁₆)	24.9 (1)	0.23
13, 22 (S) ²	43 (1 ³ / ₄)	33 (1 ⁵ / ₁₆)	17.1 (¹¹ / ₁₆)	0.16
14	38 (1 ¹ / ₂)	32 (1 ⁵ / ₁₆)	17.1 (¹¹ / ₁₆)	0.16
15	34 (1 ³ / ₈)	28 (1 ¹ / ₈)	15.6 (⁵ / ₈)	0.14
16	23 (²⁹ / ₃₂)	23 (²⁹ / ₃₂)	12.4 (¹ / ₂)	0.11

- 1) 21(S): Size of a smaller image of 21. Special-1
 21(L): Size of a larger image of 21. Special-1
 2) 22(S): Size of a smaller image of 22. Special-2
 22(L): Size of a larger image of 22. Special-2

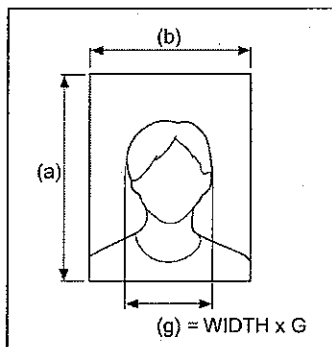

Disappearing the guidelines

- 1** Display the Setup display.
For details on displaying the Setup display, see "Displaying the Setup display" on page 32.
- 2** Select FRAME by pressing ▲ or ▼ of the control button.
- 3** Press ENTER of the control button.
 The frame select display appears.
- 4** Select OFF by pressing ▲ or ▼ of the control button.

- 5** Press ENTER of the control button.

The guidelines disappear, and the Setup display is retrieved.

Setting Power Save Mode (POWER SAVE)

When the power save mode is set, the LCD is automatically turned off after the set period has elapsed with no operation. To reactivate the LCD, press any button of the camera.

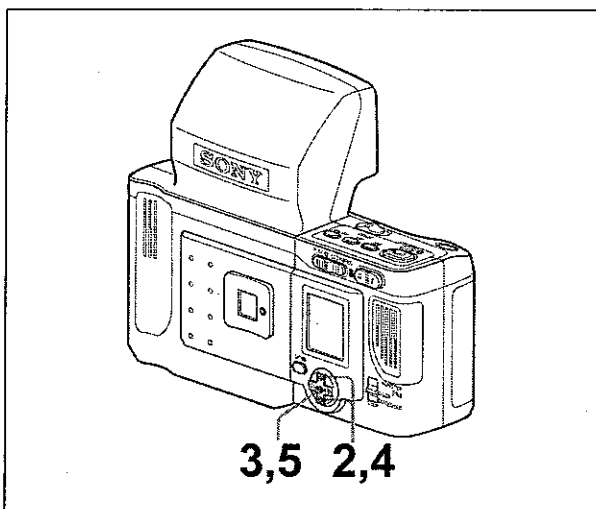

- 1 Display the Setup display.
For details on displaying the Setup display, see "Displaying the Setup display" on page 32.
- 2 Select POWER SAVE by pressing ▲ or ▼ of the control button.
- 3 Press ENTER of the control button.
The Power Save display appears.
- 4 Select the time for actiation of power save mode by pressing ▲ or ▼ of the control button.
OFF: Power save mode is not set.
3 MINUTES: The camera enters the power save mode when three minutes have elapsed.
10 MINUTES: The camera enters the power save mode when ten minutes have elapsed.
- 5 Press ENTER of the control button.
The selected time for activation of power save mode is set, and the Setup display is retrieved.

Selecting the Format of the Output Signal (VIDEO OUT)

When a video monitor is connected to the VIDEO OUT jack to monitor images, select the format of the output signal: NTSC or PAL.

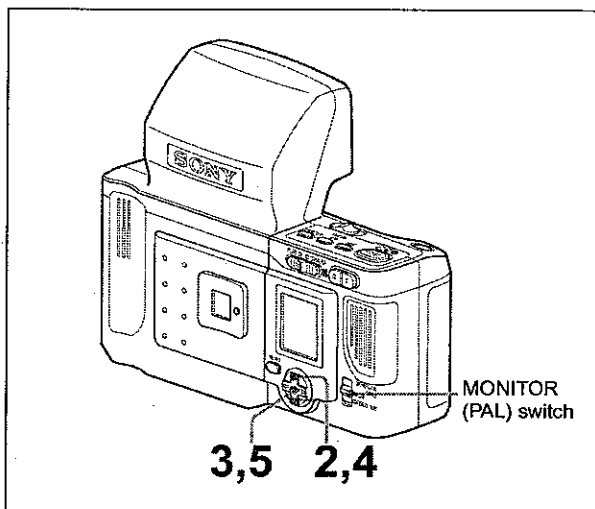

- 1 Display the Setup display.
For details on displaying the Setup display, see "Displaying the Setup display" on page 32.
- 2 Select VIDEO OUT by pressing ▲ or ▼ of the control button.
- 3 Press ENTER of the control button.
The Video Out display appears.
- 4 Select PAL or NTSC by pressing ▲ or ▼ of the control button.
- 5 Press ENTER of the control button.
The Setup display is retrieved.

When PAL is selected

If NTSC is selected, you can monitor images both on the LCD and the video monitor. If PAL is selected, you have to select the monitoring device with the MONITOR (PAL) switch, the LCD or video monitor.

LCD: For monitoring on the LCD

VIDEO OUT: For monitoring on the connected video monitor

Selecting Sound During Operation (SOUND)

When you operate the camera, you can be prompted or notified with the sound if you wish.

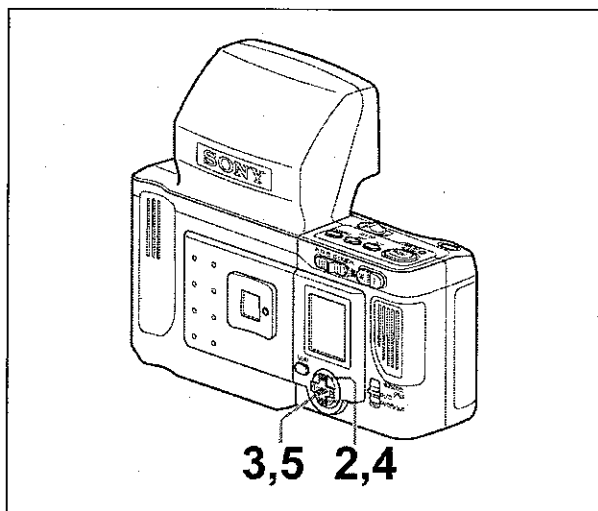

- 1** Display the Setup display.
For details on displaying the Setup display, see "Displaying the Setup display" on page 32.
- 2** Select SOUND by pressing ▲ or ▼ of the control button.
- 3** Press ENTER of the control button.
The Sound display appears.
- 4** Select the sound settings by pressing ▲ or ▼ of the control button.
OFF: No sound is heard.
SHUTTER: Sound is heard only when the release button or PRINT button is pressed.
ON: Sound is heard with all operations (excluding the zoom lever, PLAY/CAMERA switch, and MONITOR (PAL) switch).
- 5** Press ENTER of the control button.
The Setup display is retrieved.

Moving a Picture Displayed on a Nine-Picture Multiple Display (MOVE)

A picture on a nine-picture multiple display can be moved to another position.

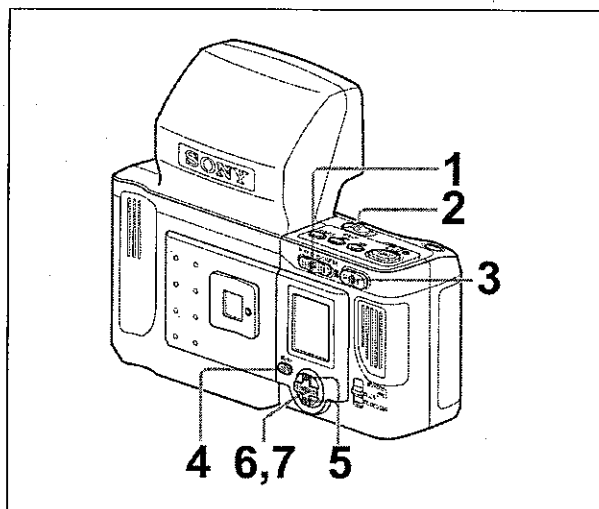

- 1** Set the PLAY/CAMERA switch to PLAY.
- 2** Set the POWER switch to ON.
- 3** Press the W side of the zoom lever twice.
A nine-picture multiple display appears.
- 4** Press the MENU button twice.
The Menu display appears.
- 5** Select MOVE by pressing ▲ or ▼ of the control button.
A cursor blinks on the nine-picture multiple display.

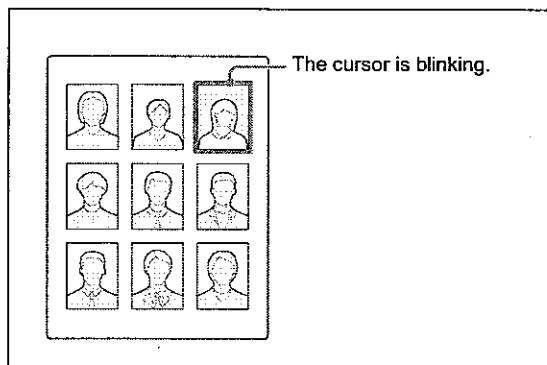

- 6** Select a picture to be moved by pressing ◀, ▶, ▲ or ▼ of the control button, and press ENTER of the control button.

The cursor stops blinking.

- 7** Move the blinking vertical line to the position where the picture is to be moved by pressing ◀, ▶, ▲ or ▼ of the control button, and press ENTER of the control button.

The picture is moved to the designated position, and the Menu display is retrieved.

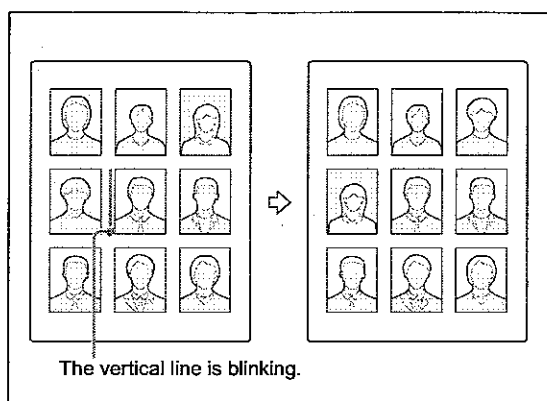

Locking the Menu of the Camera

The menu can be locked in CAMERA and PLAY mode. Once locked, the Menu display does not appear even if you press the MENU button. Then you can prevent unintended changes of the menu settings by careless operation. However only the exposure can be revised by pressing the control button.

Locking the menu

Press and hold the MENU button more than three seconds. The Menu display is turned off, and the lock mark  appears. When you press the MENU button, the Menu display does not appear, but the lock mark appears to indicate that the menu is locked.

The Menu remains locked even if CAMERA mode is changed to PLAY mode or vice versa, or the power is turned off.

Releasing the lock of the menu

Display the lock mark, and press and hold the MENU button more than three seconds until the lock mark is turned off. Then the Menu display will appear.

Adjusting the Print Quality (COLOR ADJUST)

With the MENU function of the printer, you can adjust the picture quality. You can check the adjusted results by printing a guide image of the camera.

Three sets of adjusted values can be stored in memory and retrieved later.

Adjusting the print quality

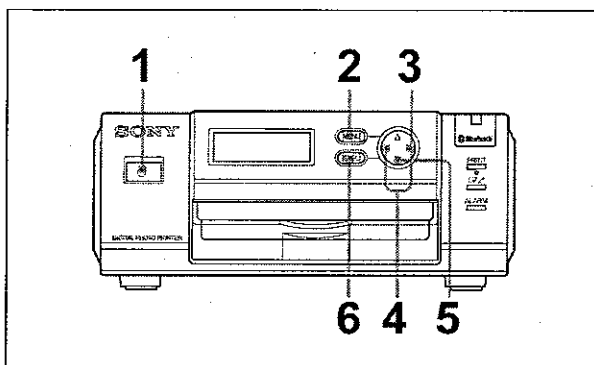

- 1** Turn on the printer by pressing the standby button.

- 2** Press the MENU button.

COLOR ADJUST [>>] appears.

- 3** Press ▶ of the control button.

CYN-RED: appears.

- 4** Press ◀ or ▶ of the control button for adjustment.

- 5** Press ▼ of the control button.

MAG-GRN: appears.

Repeat Steps 4 and 5 to make necessary adjustments.

Adjustable content for each adjustment item is as follows:

CYN-RED: Pressing ◀ gives the picture more cyan, while pressing ▶ makes it more reddish.

MAG-GRN: Pressing ◀ gives the picture more magenta, while pressing ▶ makes the picture more greenish.

YEL-BLU: Pressing ◀ makes the picture more yellowish, while pressing ▶ makes the picture more bluish.

DARK: Contrast in the dark areas is adjusted.

Pressing ▶ increases the darkness.

LIGHT: Contrast in the bright areas is adjusted.

Pressing ▶ increases the brightness.

SHARPNESS: Pressing ► makes the edges of objects in a picture sharper.

GAMMA: Pressing ◀ makes the color tone of the whole picture lighter, while pressing ► makes it deeper.

- 6 Press the EXEC button when the adjustment is completed.

The display returns to COLOR ADJUST [>>].

Printing out a guide image

To check the results of your adjustments, print out one of the camera's guide images.

Press the SIZE button of the camera to select Guide Print-RGB or Guide Print-DLGm, then execute printing.

For details, refer to the Instruction Manual (Advanced Operations).

When the UPC-X46 is used

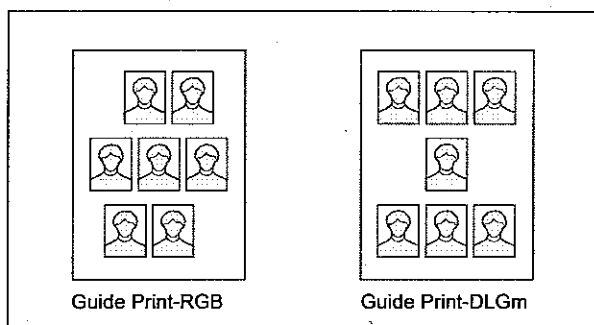

When the UPC-X34 is used

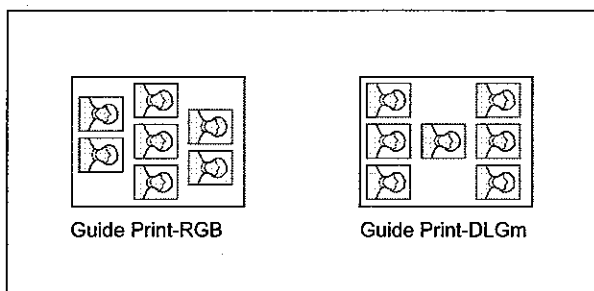

Storing your adjustments

Once color adjustment is completed, save the adjusted values as follows:

- 1 In the COLOR ADJUST [>>] display, press ► of the control button.
- 2 Press ▼ of the control button repeatedly until SAVE SETTING appears.
- 3 Press ◀ or ► of the control button to select the memory-cell number (1, 2, or 3).

- 4 Press the EXEC button.

The adjusted values are stored in the memory cell with the number selected in step 3.

Loading the adjusted values

Adjusted values stored in memory can be retrieved.

- 1 In the COLOR ADJUST [>>] display, press ► of the control button.
- 2 Press ▼ of the control button repeatedly until LOAD SETTING appears.
- 3 Press ◀ or ► of the control button to select the memory-cell number (1, 2, or 3).
- 4 Press the EXEC button.

The adjusted values stored in the memory cell with the number selected in step 3 are retrieved and in force.

To exit COLOR ADJUST

After menu operations, such as COLOR ADJUST setting, saving of adjusted values, or retrieving of stored values, are completed, press the MENU button. The display returns to Ready.

Adjusting the Printing Location (PRINT SETTING)

Adjust so that a printed image is correctly located on the print paper when the UPC-X46 is used.
The printing location can be shifted by 0.5 mm.

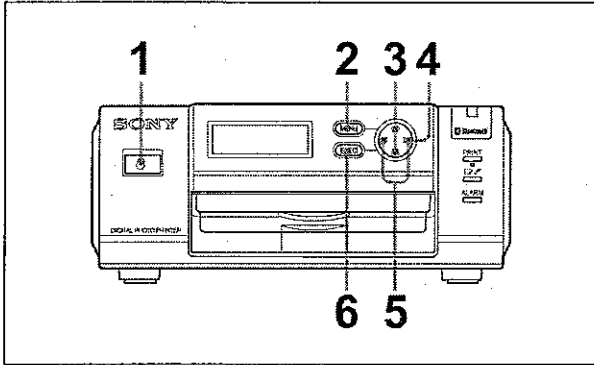

- 1 Turn on the printer.
- 2 Press the MENU button.
- 3 Press ▲ or ▼ of the control button to display PRINT SETTING [>>].
- 4 Press ► of the control button.
PRINT OFFSET: appears.
- 5 Press ◀ or ▶ of the control button to select the offset value.
- 6 Press the EXEC button.

The offset value selected in step 5 is registered, and the display returns to PRINT SETTING.

Make a test printout and check if the image is printed in the correct location on the print paper. If further adjustment is needed, repeat the above steps.

For printing an image, see "Printing a Picture" on page 19.

To exit PRINT SETTING

Press the MENU button. The display returns to Ready, and the printer is ready to print.

When the Bluetooth Function is Set to OFF

When the Bluetooth function is set to OFF, the SIZE, COLOR/B/W, PRINTER, and PRINT buttons are enabled, but printing cannot be performed. Demo Layout appears on the LCD.

Bluetooth

Bluetooth wireless technology

The bluetooth¹⁾ wireless technology allows communication between various Bluetooth devices without using cables. Devices which can use this technology include computers, computers peripheral devices, PDAs, and mobile phones. This omnidirectional communications system enables communication even if the Bluetooth device is in a bag or if there are obstacles between the devices. Also, the Bluetooth wireless technology has advanced security functions, such as scrambled frequencies and data encryption.

- When using the Bluetooth function, the distance between the camera and the printer you intend to connect must be within 10 m (3.3 feet) without obstacles.

1) The Bluetooth trademarks are owned by their proprietor and used by Sony Corporation under license.

The "Basic Imaging Profile"

The "Basic Imaging Profile" (BIP) is the specifications used when sending or receiving still images between Bluetooth devices. The main features of the BIP enable sending or receiving images, and use of the remote shutter feature of a digital still camera.

To connect with your printer, the Bluetooth device must be compatible with the "Image Push Feature" of the "Basic Imaging Profile" (BIP).

Before using the Bluetooth device, check the Bluetooth and BIP specifications of the device.

Communication between the Camera and Printer Using the Bluetooth

For the communication between the camera and printer with the Bluetooth, the following settings are required:

- The same passkey are set on the camera and printer.
- The  Bluetooth lamp is lit.

Checking the current settings

You can check the current passkey settings on the camera and printer.

Settings on the camera

- 1 Set the POWER switch to ON.
- 2 Press the MENU button twice.
- 3 Select SETUP by pressing ▲ or ▼ of the control button.

The Setup display appears.

- 4 Select Bluetooth by pressing ▲ or ▼ of the control button.

The Bluetooth display appears.

- 5 Select PROPERTY by pressing ▲ or ▼ of the control button.

You can check the passkey and address.

- 6 Press ENTER of the control button.

To exit the menu operation, press the MENU button.

Settings on the printer

- 1 Press the standby button to turn the printer on.
- 2 Press the MENU button.
- 3 Press ▼ of the control button to display Bluetooth SETTING [>>] on the operation display.
- 4 Press ► of the control button.

The Bluetooth address appears.

- 5 Press ▼ of the control button to display PASSKEY INPUT [>>] on the operation display.

- 6 Press ► of the control button.

The passkey currently set appears on the PSSKEY INPUT display.

- 7 Press the EXEC button.

To exit the menu operation, press the MENU button.

Changing the passkey settings

You can change the passkey as required.

For details on changing settings, refer to the Operating Instruction (Advanced Operations).

If the Bluetooth lamp is off

If the  Bluetooth lamp is off, turn it on in the following manner:

To turn on the Bluetooth lamp of the camera

- 1 Display the Setup display
For details on displaying the Setup display, see "Displaying the Setup display" on page 32.
- 2 Select Bluetooth by pressing ▲ or ▼ of the control button.
- 3 Press ENTER of the control button.
- 4 Select MODULE by pressing ▲ or ▼ of the control button.
- 5 Press ENTER of the control button.
The BT MODULE POWER display appears.
- 6 Check that ON is selected, then press ENTER of the control button.

The  Bluetooth lamp lights.

To turn on the Bluetooth lamp of the printer

- 1 Press the MENU button.
- 2 Press ▼ of the control button to display "Bluetooth SETTING [>>]."
- 3 Press ► of the control button.
"Bluetooth ADDR None" appears.
- 4 Press ▼ of the control button to display "MODULE POWER [>>]."
- 5 Press ► of the control button.

6 Press ◀ or ▶ of the control button to set the POWER to ON.

7 Press the EXEC button.

“REBOOTING” appears. Then the printer is restarted, and the  Bluetooth lamp lights.

Adding printers

You can use up to three printers with the camera. When printers are added to the system, you can select the printer to be used with the PRINTER button of the camera.

It is convenient that each printer have a device number (from 1 to 9).

For details on adding printers and setting device name, refer to the Operating Instruction (Advanced Operations).

Removing printers

You can remove the printer from the system.

For details on removing printers, refer to the Operating Instruction (Advanced Operations).

Locations of Parts

For details, see the pages shown in parentheses.

Camera

Front

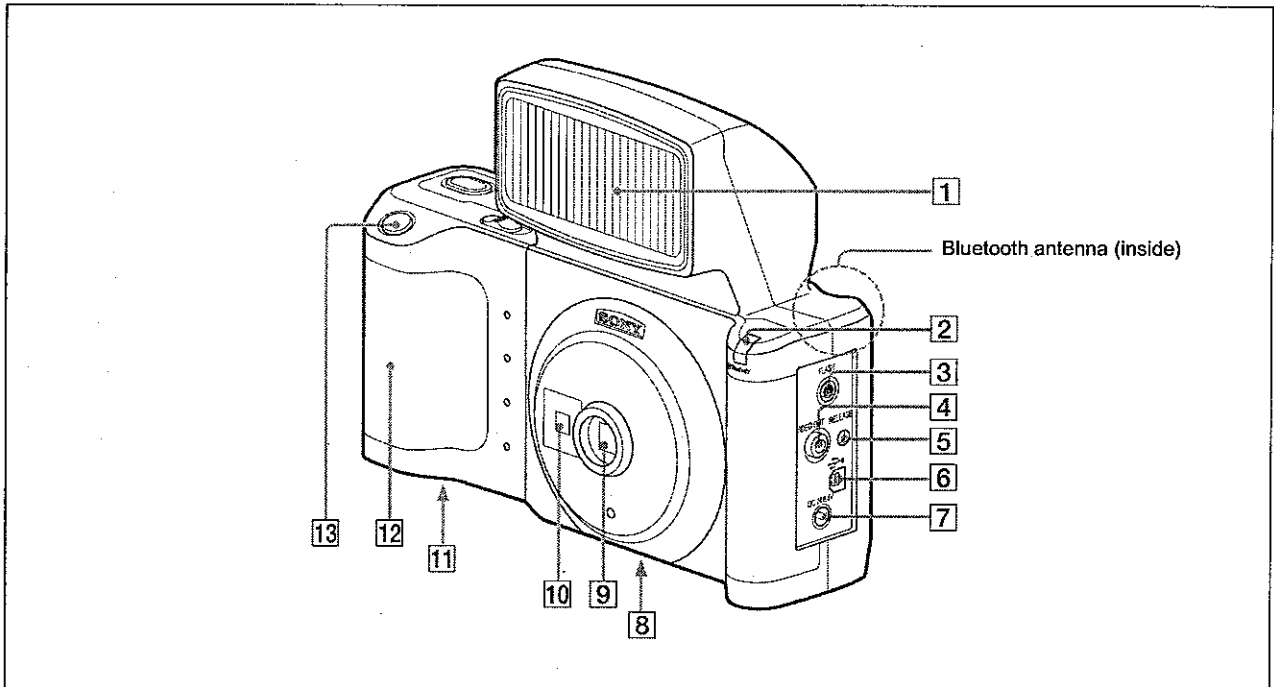

1 Flash (36)

Lights according to the selection of FLASH MODE of the menu.

2 Bluetooth lamp (48)

Lights when MODULE of Bluetooth in menu is set to ON to indicate the Bluetooth function is enabled.

3 FLASH jack

Connect a cord from an external flash that supports an X contact.

When an external flash that supports an X contact is connected with the synchronization cord, the flash lights synchronizing with the shutter.

4 VIDEO OUT jack (RCA phono) (43)

Connect a video monitor using a video cable, and you can view a picture displayed on the LCD and on the monitor's screen. The signals from the VIDEO OUT jack are for the convenience of checking the subject. To adjust the picture quality on the monitor, use the adjustment features on the monitor side.

Note

When you connect a video monitor to the VIDEO OUT jack with VIDEO OUT of the menu set to PAL, you have to set the MONITOR (PAL) switch to VIDEO OUT to view a picture on the video monitor.

5 RELEASE jack (minijack)

Connect a remote release.

The same action is obtained as if the release button were pressed all the way.

6 USB jack

To use the camera with a computer, connect to the USB jack of the computer using the commercially available USB cable.

Pictures stored in the camera's memory can be stored on a computer, printed using a computer on which you have the supplied utility software installed.

7 DC IN 8.4V jack (13)

Connect the supplied AC power adaptor for the AC power operation of the camera.

8 Tripod screw hole (13)

Used to attach the camera to the tripod.

9 Lens (f = 7.5 to 19.8 mm, F-2.8 to F-4.8)

Auto focus lens with optical zoom.

10 Viewfinder

You can see the subject through the viewfinder and can shoot a picture without using the LCD monitor. Use the viewfinder to check the subject. The picture seen through the viewfinder does not reflect the framing correctly.

11 Battery compartment lid (11)

Insert four NH-AA batteries and the lithium button battery, and close the lid.

12 Grip

The camera has a 90-degree rotary grip on the LCD side. When the subject is sitting, the camera position has to be low to keep the lens and the subject's eyes at the same level. In such a case, rotating the grip on the LCD side allows you to hold the camera in a natural posture.

Note

When turning the grip, do not apply excessive force. Avoid turning the grip frequently to avoid wear on the rotating parts.

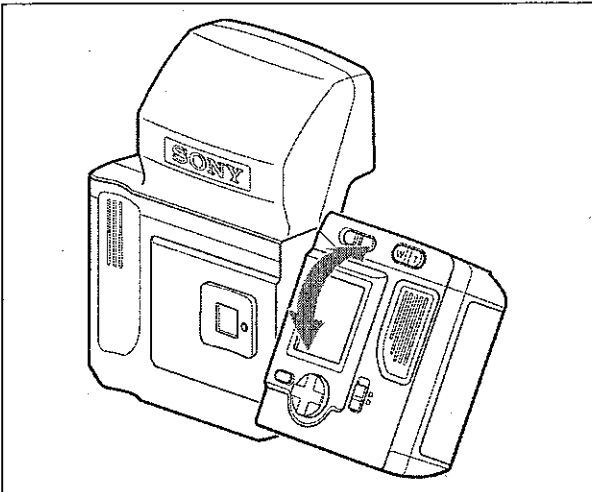

13 Release button (18)

Press to take a picture shown on the LCD and record it in memory.

Pressing this button halfway activates the auto-focus function. Pressing this button further releases the shutter. The picture is compressed in JPEG format and recorded in memory.

This button is enabled when the PLAY/CAMERA switch is set to CAMERA.

Rear

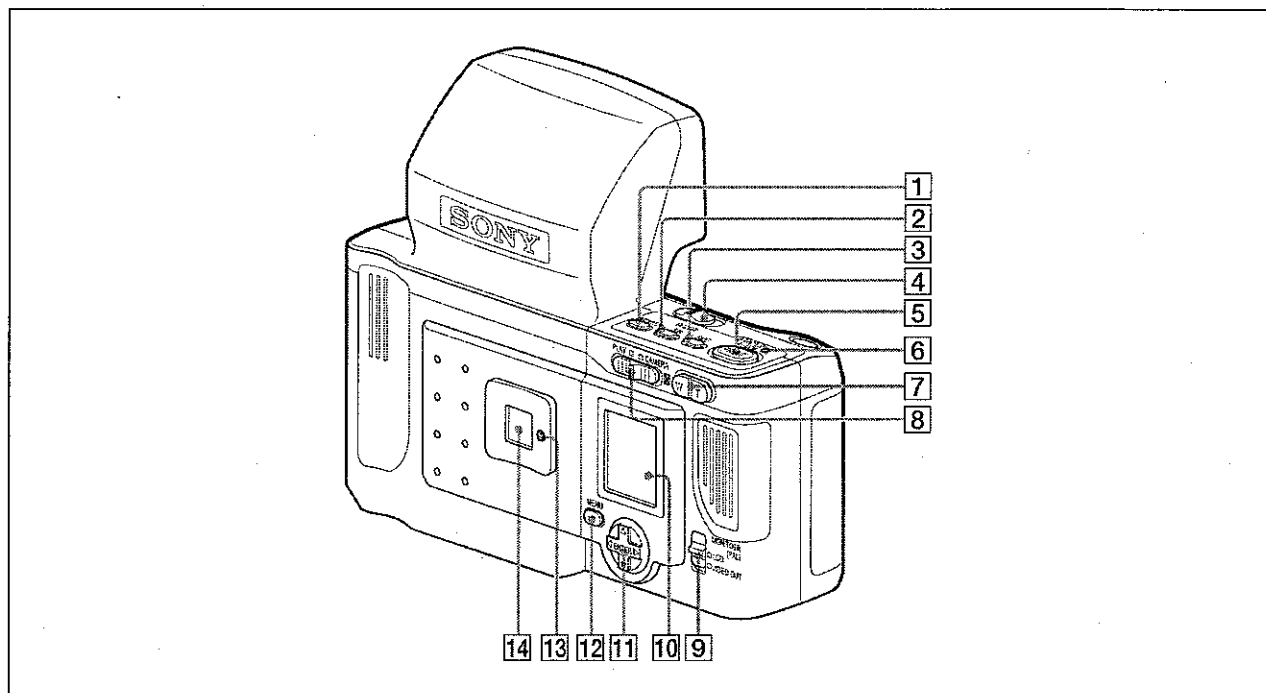

1 PRINTER button

Selects a printer when multiple printers are used.

For details, refer to the Operating Instructions (Advanced Operations).

2 COLOR/B/W button (20)

Selects COLOR or B/W (black and white) for a printout.

3 SIZE button (19)

Selects the size for a printout.

4 POWER switch (17)

Turns the power to the camera ON or OFF.

Note

When the POWER switch is set to OFF, the latest status of the camera is stored in memory, then the standby lamp goes out to indicate that the power is turned off completely. While the standby lamp is lit, do not disconnect the AC power adaptor or remove the batteries.

5 PRINT button (19)

Press to print a picture displayed on the LCD. When you press this button once, the layout preview display for a printout is displayed on the LCD, and you can set the number of sheet to be printed. When you press this button again, the picture data are transmitted to the printer and are printed. While transmitting the data, TRANSMITTING appears on the LCD.

To turn off the layout preview display, press the MENU button.

6 PRINTER ALARM lamp

Lights when some trouble occurs on the printer.

When multiple printers are used, the status of the printer selected with the PRINTER button is indicated. Check the printer.

7 Zoom lever (18)

When the PLAY/CAMERA switch is set to CAMERA

Adjusts the framing of the picture. For identification portraits, the size of a face on a photograph is designated in most cases. The zoom function allows you to adjust the size of the face without moving the camera position. This feature allows smooth shooting, minimizing the time the subject must sit without moving. The maximum magnification is 1.3 times or 2.6 times.

T: For a telephoto picture

W: For a wide picture

When the PLAY/CAMERA switch is set to PLAY

Switches between nine-picture multiple display and single-picture display.

T: Nine-picture multiple display is switched to single-picture display.

W: Single-picture display is switched to nine-picture multiple display.

8 PLAY/CAMERA switch (17, 21)

Use this switch to toggle between playback and recording modes.

CAMERA: Set the switch at this position to take a picture.

PLAY: Set the switch at this position to view the images stored in memory.

9 MONITOR (PAL) switch (43)

When a video cable is connected to the VIDEO OUT jack and VIDEO OUT of the menu is set to PAL, this switch is enabled. Select which you use for monitoring a picture, the LCD or video monitor.

LCD: For viewing the picture on the LCD

VIDEO OUT: For viewing the picture on the video monitor

When VIDEO OUT is set to NTSC, you can monitor a picture both on the LCD and a video monitor.

10 Liquid-crystal display (LCD)

When the PLAY/CAMERA switch is set to CAMERA, the scene picked up by the lens appears.

When the PLAY/CAMERA switch is set to PLAY, the picture stored in memory appears.

When the camera is connected to a computer using the USB cable, no picture is displayed on the LCD.

11 Control button (21, 32)

When the PLAY/CAMERA switch is set to PLAY, press to select a picture.

In MENU operation, press to select a menu item and to settle the selection.

12 MENU button (18, 32)

Press to display the Menu display. Press it again to disappear the Menu or layout display.

13 Standby lamp (18)

The lamp is lit or flashing to indicate the following conditions.

When the PLAY/CAMERA switch is set to CAMERA

Flashing in red: Preparing for recording, charging the flash, storing the data (recording is disabled).

Quickly flashing in red: No battery power remains.

Lit in red: Memory full

Flashing in green: Manual setting for exposure, aperture or white balance

Lit in green: Standby for recording

When the PLAY/CAMERA switch is set to PLAY

Lit in red: Some trouble has occurred. Contact your Sony service facility.

Flashing in green: Memory full

Quickly flashing in green: No battery power remains.

Lit in green: Normal operation

14 Viewfinder

You can see the subject through the viewfinder and can shoot a picture without using the LCD monitor.

Use the viewfinder to check the subject. The picture seen through the viewfinder does not reflect the framing correctly.

Printer

Front

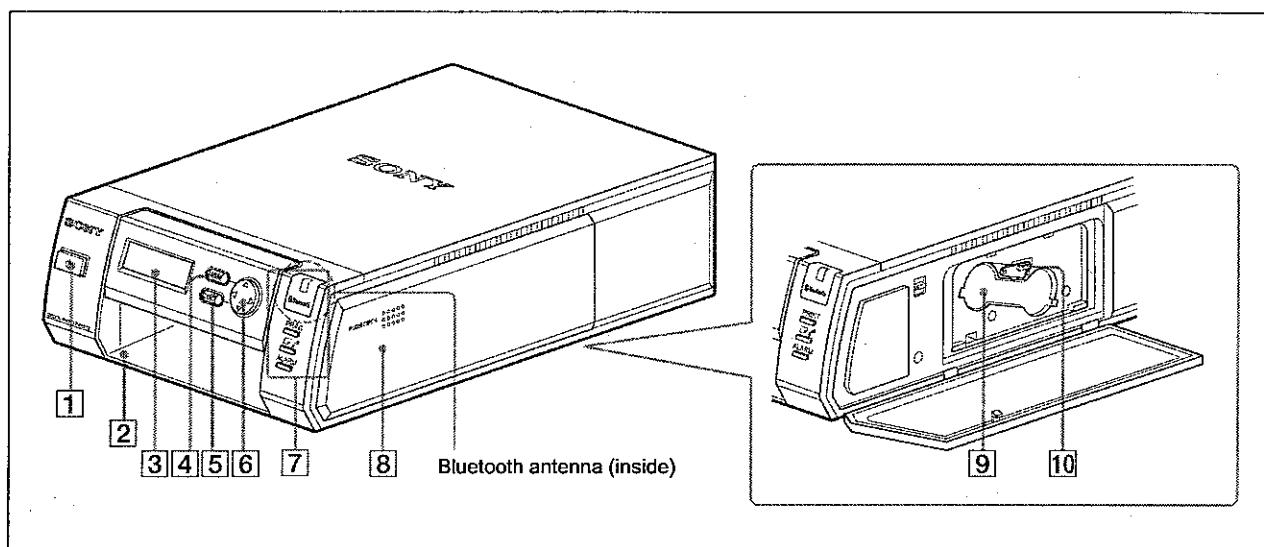

1 (standby) button and lamp (18, 45)

Press to turn on the printer, and the lamp lights. Pressing it again makes the lamp go out, and the printer enters the standby mode.

2 Paper tray slot (16)

Insert the paper tray.

3 Operation display

When the power turned on, the operation mode or menu item appears.

4 MENU button (20, 45)

Press to display the menu item or to cancel any changes made on the menu items that you have not registered.

5 EXEC button (20, 46)

Press to decide the selection for each Menu items.

6 Control button (20, 45)

Press to select a menu item and to settle the selection.

7 Lamps

Bluetooth[®] lamp: Lights when the Bluetooth function is enabled.

PRINT lamp: Lights while printing is in progress, and flashes while the printer is receiving image data.

lamp: Lights if paper runs out, the print cartridge is out of ink, or cartridge and paper of different types or sizes are mixed.

ALARM lamp: Lights in case of occurrence of problem.

8 Cartridge compartment cover (14)

Open the cover to insert and remove the print cartridge.

9 Cartridge compartment (14)

Insert the print cartridge.

10 Cartridge eject lever (14)

Push up the lever to eject the inserted cartridge.

Note

The lever is disabled while printing.

Rear

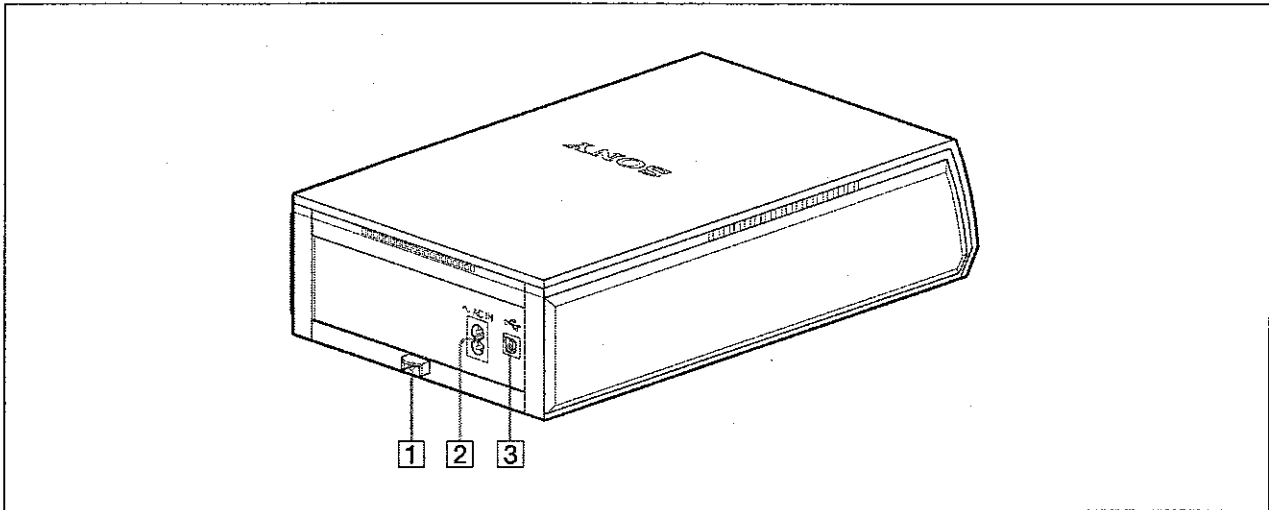

1 Paper jam remove cover (61)

When a paper jam occurs, remove this cover, and remove the jammed paper.

2 ~AC IN connector (17)

Connect to a wall outlet using the supplied AC power cord.

3 USB connector

Connect to the USB connector on a computer using the USB cable.

Note

When connecting a computer using a USB cable, depending on the type of computer, normal operation may not be obtained. In such a case, use a commercially available USB hub.

Precautions

Safety

- Operate the printer and the AC power adaptor using the power source specified in "Specifications" (page 58).
- Be careful not to damage the power cord by placing or dropping heavy objects on it; it is dangerous to use the printer or AC power adaptor with a damaged power cord.
- If you do not intend to use the printer or AC power adaptor for a long time, disconnect the power cord.
- Unplug the power cord by grasping the plug, not the cord itself.
- The negligible amount of electric current will flow into the AC power adaptor as long as the AC power adaptor is plugged into the wall outlet.
- While the AC power adaptor is in use, it gets warm. But this is normal.
- Be sure that nothing metallic comes into contact with the metal parts of the AC power adaptor or connecting plate. If it does, a short may occur and the unit may be damaged.
- Always keep the metal contacts of the AC power adaptor clean.
- Do not apply mechanical shock or drop the unit.
- Do not disassemble or convert the unit.
- Do not remove the cover. There is a danger of electric shock from the internal parts.
- Be careful not to spill water or other liquids on the unit, or to allow combustible or metallic material to enter the cabinet. If used with foreign matter in the cabinet, the unit is liable to fail, or present a risk of fire or electric shock.
- Ventilation holes are provided to prevent the printer from overheating. Be careful not to obstruct them with other units or by covering the printer with a cloth etc.
- If the printer malfunctions or if a foreign body falls into the cabinet, disconnect the power immediately and consult your Sony service facility or your Sony dealer.

Installation

- Avoid placing the printer or camera in a location subject to:
 - mechanical vibration
 - high humidity
 - excessive dust
 - where it is exposed to rain
 - direct or excessive sunlight
 - extremely high or low temperatures
 - close to sources of strong magnetism
 - close to sources of powerful electromagnetic radiation, such as radios or TV transmitters
- Do not use other electronic equipment near the printer. It will not work properly in strong electromagnetic fields.
- Do not place a heavy object such as a monitor on the printer.
- Keep the AC power adaptor away from AM receivers, because it will disturb AM reception.

Condensation

- If the printer is subject to wide and sudden changes in temperature, such as when it is moved from a cold room to a warm room or when it is left in a room with a heater that tends to produce large amounts of moisture, condensation may form inside the printer. In such cases the printer will probably not work properly, and may even develop a fault if you persist in using it. If condensation forms, turn off the power and leave the printer to stand for at least one hour.
- If the printing pack is subjected to wide and sudden changes in temperature, condensation may form on the print cartridge or paper. This will cause the printer to malfunction. Also, if the printing pack is used in this state, spots are likely to appear on the printout. Therefore, avoid storing the printing pack in locations subject to wide and sudden changes of temperature.
- To store a half-used printing pack, replace it in its original packing and reseal the package. If possible, keep the sealed printing pack in a cool, dark location. To subsequently use the printing pack, place it, in its sealed package, in a warm room for several hours. Doing so prevents condensation from forming when the printing pack is removed from its package.

Location

To prevent internal heat built-up, leave enough room around the printer for air to circulate through the vents on the left hand side of the cabinet.

On transportation

- Do not transport the printer with the supplied accessories. Doing so may cause malfunction.
- Retain the original carton and packing materials in case you have to transport the unit in the future.

Operation

Test shooting

Before shooting, you should always take a few test shots and review them to see that the camera is functioning normally.

Copyright laws

You may take pictures for your personal enjoyment with this digital still camera. However, it is illegal to take pictures of items protected by copyright laws without the permission of the copyright owner. Keep this in mind when shooting in concerts, shows and exhibitions, etc. —many of the items on display are protected by copyrights.

Cleaning

- Before cleaning the printer, turn the power of the printer off and unplug the power cord.
- Clean the cabinet, panel and controls with a soft dry cloth, or a soft cloth lightly moistened with a mild detergent solution. Do not use any type of solvent, such as alcohol or benzine, which may damage the finish.
- Use a blower to remove dust from the lens.

Batteries

Be sure to observe followings

- To prevent accident from a short circuit, do not allow metal objects to come into contact with the battery terminals.
- Keep the batteries away from fire.
- Never expose the batteries to temperature above 60°C, such as in a car parked in the sun or under direct sunlight.
- Keep the batteries dry.
- Do not expose the batteries to any mechanical shock.
- Do not short the terminals.
- Do not disassemble nor modify the batteries.
- Attach the batteries to electronic equipment securely.
- Please refer to the operating instruction of the electronic equipment for further information.

Charging the batteries

- Use only the specified charger or equipment with the charging function.
- To enable to charge the battery efficiently, we recommend charging the batteries fully in an ambient temperature of between 0°C to 35°C.

Using the batteries

- Charge before using.
- Battery performance decreases in low-temperature surroundings. So, the time that the batteries can be used is shorter in cold places. We recommend the following to use longer:
 - Put the batteries in a pocket to warm it up, and insert it in your electronic equipment immediately before you start taking shots.
- Have spare batteries handy for two or three times the expected recording time, and make trial recording before taking the actual recording.
- If the power may go off although the remaining battery time indicator indicates that the batteries have enough power to operate, charge the batteries fully again so that the indication on the remaining battery time indicator is correct. Note, however, that the correct battery indication sometimes will not be restored if it is used in high temperatures for a long time or left in a fully charged state, or the batteries are frequently used. Regard the remaining battery time indication as the approximate shooting time.

How to store the batteries

If the batteries are not to be used for a long time, do the following procedure once per year to maintain proper function.

- 1 Fully charge the battery.
- 2 Discharge on your electronic equipment.
- 3 Remove the batteries from the equipment and store them in a dry, cool place.

Battery life

- The battery life is limited. Battery capacity drops little by little as you use it more and more, and as time passes. When the available battery time is shortened considerably, a probable cause is that the batteries have reached the end of its life. Please buy a new batteries.
- The battery life varies according to how it is stored and operating conditions and environment for each batteries.

Warranty for Recorded Content

Contents of the recording cannot be compensated if recording or playback is not made due to a malfunction of the batteries, etc.

You don't have to discharge the batteries before recharging.
Charging while some capacity remains does not affect the original battery capacity.

Specifications

with a 35-mm film camera), auto focus
F-value: F2.8 (at W) to F4.8 (at T)

Camera

General

Power supply	Supplied from Sony NH-AA Batteries or from an AC power adaptor (8.4 V DC)
Operating temperature	5°C to 35°C (41°F to 95°F)
Storage temperature	-20°C to +60°C (-4°F to +140°F)
Operating humidity	20% to 80% (non condensation)
Dimensions (w/h/d)	230 × 190 × 74 mm (9 1/8 × 7 1/2 × 3 inches)
Mass	Approx. 920 g (2 lb)
System	
Camera type	Digital still camera
Recording/playback system	Frame digital
Data compression/decompression system	JPEG base line system
Recording medium	Built-in 32 MB flash memory
Picture elements	1/1.8 inch 4M CCD solid-state picture element
Recording capacity	approx. 20 or more pictures (High resolution) approx. 80 or more pictures (Middle resolution) approx. 200 or more pictures (Standard resolution)
Image recording	2288 × 1712 pixels (HIGH) 1280 × 960 pixels (MID) 832 × 624 pixels (STD)
Erase method	1 picture erase, all picture erase
White balance	AUTO, One Push, 3000K to 7000K (500K steps)
Photometric system	Center weighted/face/upper background metering system
Exposure control type	Iris priority shutter range programmed exposure
Shutter speed	1/2 to 1/1000 second
Photographic sensitivity	Equivalent to ISO 100
LCD monitor	1.8-inch cold polysilicone TFT color LCD viewfinder 110,000 pixel
Lens	f = 7.5 to 19.8 mm, 2.6 times (equivalent to a 36 to 96-mm lens

Input/output connectors

VIDEO OUT	3.5 mm ø (phono jack) 1.0 Vp-p, 75-ohms unbalanced, sync negative, composite video NTSC color TV system Burst level: 0.25 V ±0.03 V (10%) Sync level: 0.25 V ±0.03 V (10%) PAL color TV system Burst level: 0.30 V ±0.03 V (10%) Sync level: 0.30 V ±0.03 V (10%)
USB	ver 1.1
DC IN 8.4V	8.4 V DC
RELEASE	3.5 mm ø (minijack)

Printer

Power supply	100 – 240 V AC, 50/60 Hz
Current consumption	1.1 A max.
Operating temperature	5°C to 35°C (41°F to 95°F)
Storage/transport temperature	-20°C to +60°C (-4°F to +140°F)
Operating humidity	20% to 80% (non condensation)
Maximum dimensions (w/h/d)	203 × 85 × 305 mm (8 × 3 3/8 × 12 1/8 inches)
Mass	Approx. 2.7 kg (5 lb 15 oz) (main unit only)
Printing method	Four-surface sequential sublimation thermal transfer process (yellow, magenta, cyan, laminate)
Printing resolution	403 × 403 dpi
Thermal head	403 dots/inch
Printing gradations	8 bits for yellow, magenta, cyan
Printing time	UPC-X46: 100 sec./sheet UPC-X34: 65 sec./sheet
Paper supply method	Autofeed from paper tray
Maximum capacity of paper tray	UPC-X46: 25 sheets UPC-X34: 30 sheets
Paper eject method	Front ejection Sheets are ejected in order on top of paper tray
Printing capacity of ribbon cartridge	UPC-X46: 25 sheets UPC-X34: 30 sheets
Inputs	AC IN (power inlet)

Maximum print size

UPC-X46: 101.6 × 151.4 mm
 (4 × 6 1/8 inches) (no border)
 UPC-X34: 70.1 × 95.3 mm
 (2 7/8 × 3 7/8 inches) (no border)

Print pixels

UPC-X46: 1664 × 2440 dots
 UPC-X34: 1112 × 1512 dots

USB interface**Data-transmission system**

Compliant with the Universal Serial
 Bus Specifications Revision 1.1

Pin assignment of the USB connector

I/O	Signal	Function
	V _{CC}	Cable power, maximum current: 100 mA
I/O	-Data	Data
I/O	+Data	Data, can be pulled up to +3.3 V via a 1.5-kohm resistor
	GROUND	Cable ground

Bluetooth specifications**Communication type**

Bluetooth standards, ver.1.1

Maximum transmission speed¹⁾

About 723 Kbps

Output

Bluetooth standards, Power Class 2

Communication distance²⁾

About 10 m (3.3 feet) without
obstacles

Compatible Bluetooth profile³⁾

Basic Imaging Profile (Image Push
Responder)

Frequency band 2.4 GHz (2.400 GHz – 2.4835 GHz)

- 1) Maximum data transmission speed based on Bluetooth standards, Ver.1.1. This speed depends on the distance between the devices, obstacles, radio wave conditions, application software, or the OS.
- 2) This distance depends on the distance between the devices, obstacles, radio wave conditions, application software, or the OS.
- 3) This specification is in accordance with the intended use between two Bluetooth devices. This is defined by the Bluetooth standards.

AC power adaptor**Power requirements**

100 – 240 V AC, 50/60 Hz

Power consumption

31 VA (100 V)
42 VA (240 V)

Output voltage DC 8.4 V, 1.5 A in operating mode**Operating temperature**

5°C to 35°C (41°F to 95°F)

Storage temperature

–20°C to +60°C (–4°F to +140°F)

Dimensions (w/h/d)

Approx. 125 × 39 × 62 mm
 (5 × 1 9/16 × 2 1/2 inches)
 including projecting parts

Mass

Approx. 230 g (8 oz)

Battery Charger**Power requirements**

100 – 240 V AC, 50/60 Hz

Power consumption

10 VA (100 V)
16 VA (240 V)

Output

1.2 V DC
AA: 920 mA × 2/460 mA × 4

Dimensions (w/h/d)

65 × 105 × 26 mm
 (2 5/8 × 4 1/4 × 1 3/16 inches) (not
including plug)

Mass

Approx. 110 g (4 oz) (not including
batteries)

Operating temperature

0°C to 35°C (–4°F to +95°F)

Supplied accessories

Paper tray for the UPC-X46 (1)

Paper tray for the UPC-X34 (1)

Tray cover (1)

Paper holder (2)

AC power cord for printer (1)

AC power adaptor PCS-AC08 (1)

AC power cord for the PCS-AC08 (1)

Batteries NH-AA (4)

Lithium button battery CR-2025 (1)

Battery charger (1)

AC power cord for battery charger (1)

Cleaning cassette (1)

CD-ROM (1)

Operating Instructions (2)

Software license agreement (1)

Optional accessories

UP-DX100 Digital Photo Printer

10UPC-X46 Self-laminating Color Printing Pack (250
sheets)

10UPC-X34 Self-laminating Color Printing Pack (300
sheets)

Design and specifications subject to change without
notice.

Troubleshooting

If you run into any problem when using your UPX-C200, use the following table as a guide to troubleshoot the problem. If the problem persists, contact your Sony dealer or local authorized Sony service facility.

Camera

Symptom	Possible causes/Action
Power is not turned off even if the POWER switch is set to OFF.	<ul style="list-style-type: none"> The camera is hung up. <ul style="list-style-type: none"> → Disconnect the AC power adaptor from the camera or open the battery compartment lid.
The POWER switch of the camera is set to ON, but the camera and printer are not connected.	<ul style="list-style-type: none"> → Set the MODULE of Bluetooth on the Menu to OFF then ON again. Refer to the Operating Instructions (Advanced Operations.) → Remove the printer, and add it again. (Refer to the Operating Instructions (Advanced Operations).)

While Shooting

Symptom	Possible causes/Action
A picture cannot be taken when you press the release button.	<ul style="list-style-type: none"> The PLAY/CAMERA switch is not to set to CAMERA. <ul style="list-style-type: none"> → Set the switch to CAMERA. The camera is taking a picture or charging the flash (the standby lamp is flashing in red). <ul style="list-style-type: none"> → Wait until the standby lamp lights or flashes in green. The memory is full (the standby lamp is lit in red). <ul style="list-style-type: none"> → Check the displayed remaining number of shots that can be taken. If zero, erase any picture that is not necessary. → Set AUTO ERASE to ON. (Refer to the Operating Instructions (Advanced Operations).)
The flash does not light.	<ul style="list-style-type: none"> Flash Mode is not set appropriately. <ul style="list-style-type: none"> → Set FLASH MODE in menu to A$\frac{1}{2}$, $\frac{2}{3}$ or M$\frac{1}{2}$. The cord of the external flash is not connected to the camera. <ul style="list-style-type: none"> → Connect the cord of the external flash to the FLASH jack of the camera. The batteries are discharged. <ul style="list-style-type: none"> → Charge the batteries or replace them with a new one. The flash may be out of life. <ul style="list-style-type: none"> → Contact the Sony service facility.

Liquid Crystal Display of the Camera

Symptom	Possible causes/Action
No playback picture appears.	<ul style="list-style-type: none"> The MONITOR (PAL) switch of the camera is set to VIDEO OUT when a video cable is connected and VIDEO OUT of the menu is set to PAL. <ul style="list-style-type: none"> → Set the switch to LCD. → Disconnect the video cable.
If played back in cold weather, the picture may seem to present curved sides. The image presents some red, blue and green dots, or there are black spots visible.	<ul style="list-style-type: none"> Condition due to the liquid crystals. <ul style="list-style-type: none"> → Normal condition

Picture Quality

Symptom	Possible causes/Action
The picture is out of focus.	<ul style="list-style-type: none"> Focus is off. <ul style="list-style-type: none"> → Check the distance between the lens and the subject and place the subject at the range within which the focus is in. The camera was moved when you pressed the release button. <ul style="list-style-type: none"> → Hold the camera correctly, then press the release button slowly. FLASH MODE is set to A$\frac{1}{2}$ or $\frac{2}{3}$, and the shutter speed is too slow. <ul style="list-style-type: none"> → Set the appropriate shooting conditions. (Refer to the Operating Instructions (Advanced Operations).) The lens is dirty. <ul style="list-style-type: none"> → Clean the lens.
The picture is too dark.	<ul style="list-style-type: none"> The flash was blocked by a finger or other obstacle. <ul style="list-style-type: none"> → Hold the camera correctly, and make sure nothing blocks the flash. The subject was too far away. <ul style="list-style-type: none"> → Take the picture within range of the flash. → Compensate the exposure. The subject was backlit. <ul style="list-style-type: none"> → Use the flash.
The colors of the picture taken indoors are not correct.	<ul style="list-style-type: none"> This is due to fluorescent lighting. <ul style="list-style-type: none"> → Set the white balance correctly. (See "Adjusting the white balance (W.B.);" on page 37).

Symptom	Possible causes/Action
A part of the picture is missing.	A finger was blocking the lens. → Hold the camera correctly, and make sure a finger does not block the lens.
It is dark around the picture.	• Zoom is set higher than 1.3x when the built-in flash is used. → Set the zoom position to 1.3x or lower.

Printer

Symptom	Action
Cannot operate the printer after the power switch is turned on.	• The AC power cord is not connected correctly. → Connect the AC power cord to an AC outlet securely.
Cannot print.	• The print paper and print cartridge do not match. → Use the recommended printing pack, the same size of the print paper and print cartridge. • The thermal head may be overheated. "Waiting" appears on the operation display. → Leave the printer until the head cools down and the printer resumes printing. • The print paper may jam. → Remove the jammed paper. (See "If paper jams" on page 61.)
The beeps sound.	→ Check that you are following the correct procedures.
Cannot remove the print cartridge.	→ The print cartridge cannot be removed while printing. Wait until printing is finished. If this does not solve the problem, contact your Sony service facility or your Sony dealer.
The ALARM indicator is lit or an error message is displayed.	→ Follow the instructions on the screen.
There is a white line or dots in the printed pictures.	• Dust may be attached to the thermal head. → The print head or paper path may be soiled. Use the supplied cleaning cassette to clean the head and path. (See "Cleaning the inside of the printer" on page 61.)

If paper jams

If the print paper jams, the ALARM lamp lights, an error message appears, and printing stops.

- 1 Turn the printer off.

- 2 Remove the paper tray, and remove the jammed paper from the paper tray slot.
- 3 Remove the paper jam remove cover on the rear panel, and check that the paper does not remain in the printer. If the jammed paper is still in the printer, remove it.

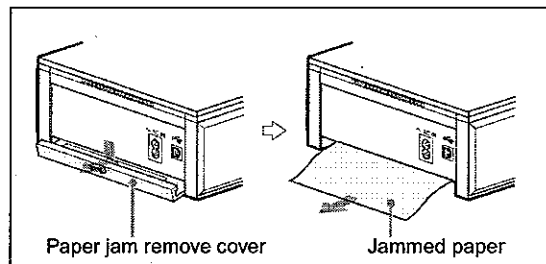

- 4 After removing the jammed paper, be sure to replace the cover.
- 5 Insert the paper tray.
- 6 Turn on the printer.

Note

If you cannot remove the jammed paper, contact your Sony dealer.

Cleaning the inside of the printer

If white lines or dots are printed on the pictures, clean inside the printer using the supplied cleaning cassette and the protective sheet contained in the printing pack.

Notes

- Make cleaning only when there are white lines or dots on the print.
- When you can obtain proper printing performances, cleaning will not improve the printed picture quality.

- 1 Remove the paper tray from the printer. If there is print paper in the tray, remove the print paper from the tray.
- 2 Place the protective sheet with the imprint side facing down and the arrow pointing in the same direction as the arrow in the tray.
- 3 Open the cartridge compartment cover and remove the print cartridge.
- 4 Insert the supplied cleaning cassette into the printer and close the cartridge compartment cover.

A buzzer sounds, and "HEAD CLEANING/PUSH [EXEC]" appears on the operation display.

5 Press the EXEC button.

The cleaning cassette and protective sheet will clean inside the printer. After the cleaning is finished, the protective sheet is automatically ejected.

6 Remove the cleaning cassette from the printer and set the print cartridge and print paper.

Bluetooth Function

Symptom	Cause/solution
Data cannot be transmitted.	<ul style="list-style-type: none"> • The distance between the device and the printer is too great. → Locate the devices within the maximum communicable distance. • The antenna portion of the printer and/or the camera is covered with a hand, etc. → Do not cover the antenna portion. • The device you wish to connect with the printer has been already connected with another device. → Reconnect the device with the printer after the device's task with another device is finished. • Authentication failed. → Reconnect the printer with the device, and enter the same passkey correctly on both devices. • The connected device interrupted the transmission. → Check the status of the connected device, then reconnect. • The Bluetooth connection is interrupted on the side of the connected device. → Check the status of the connected device.
The connection is disconnected from the desired device.	<ul style="list-style-type: none"> • The same passkey is not entered. → Enter the same passkey correctly both on the printer and the device within 30 seconds. • The device disconnected or ended the connection. → Check the status of the device, try to connect to the device again, and enter the passkey correctly.
Authentication failed.	<ul style="list-style-type: none"> • The same passkey is not entered. → Enter the same passkey correctly both on the printer and the camera. • The device disconnected or ended the connection. → Check the status of the device, try to connect to the device again, and enter the passkey correctly.

Symptom	Cause/solution
Data transmission speed is too low.	<ul style="list-style-type: none"> • The antenna portion of the printer and/or the camera is covered with a hand, etc. → Do not cover the antenna portion. Data transmission speed varies depending on the distance between the printer and the camera, obstacles, or radio wave conditions. Change the position of the printer or set the printer closer to the device.
Even with the distance between the printer and the desired device within 10 m (3.3 feet), connection cannot be established.	<ul style="list-style-type: none"> • The antenna portion of the printer and/or the camera is covered with a hand, etc. → Do not cover the antenna portion. Data transmission speed varies depending on the distance between the printer and the camera, obstacles, or radio wave conditions. Change the position of the printer or set the printer closer to the device. • The desired device is now connecting to another device. → When the device is connected to another device, the device may not be displayed as an available device or be connectable at that time. • The device is not connectable with the Bluetooth functions. → Set the device so that it is connectable.

Battery Charger

Symptom	Cause/solution
The CHARGE lamp is flashing.	<ul style="list-style-type: none"> • Battery life ends or some trouble occurs on the batteries. → Use new NH batteries. • Batteries other than NH batteries are being charged. → Replace them with the NH batteries.
The CHARGE lamp does not light.	<ul style="list-style-type: none"> • The batteries are installed incorrectly. → Install the batteries correctly. • Imperfect contact of batteries → Clean the contacts of the battery charger, and the ⊕ and ⊖ terminals of the batteries. • Imperfect contact with the power supply → Clean the plug. → Connect the battery charger to another wall outlet.

Error messages

Error message		Cause/Action
Camera	Printer	
SET MEDIA	RIBBON END SET CARTRIDGE	<ul style="list-style-type: none"> The print cartridge has run out. →Replace the print cartridge.
	SET PAPER PUSH EXEC	<ul style="list-style-type: none"> The print paper has run out. →Put print paper in the paper tray and press the EXEC button. The paper tray is not inserted in the printer. →Insert the paper tray and press the EXEC button.
CHECK PRINTER	PAPER JAMMING REMOVE PRINTS	<ul style="list-style-type: none"> The print paper may jam. →Remove the jammed paper, if any. See “If paper jams” on page 61.
	MEDIA MISMATCH PUSH EXEC	<ul style="list-style-type: none"> The print paper and print cartridge do not match. →Put the same size of the print paper as the print cartridge, and press the EXEC button.
	REMOVE PRINTS PUSH EXEC	<ul style="list-style-type: none"> The print paper remains at the ejection slot. →Remove the paper tray, then the print paper. Then press the EXEC button.
	PRINTER SERVICE CALL	<ul style="list-style-type: none"> Some trouble has occurred on the printer. →Contact Sony service facilities or your Sony dealer.
	Bluetooth SERVICE CALL	<ul style="list-style-type: none"> Some trouble has occurred on the Bluetooth function. →Contact your Sony service facility or your Sony dealer.
(animation)	—	<ul style="list-style-type: none"> The printer is printing a picture. →Wait until printing is finished, and try again.
COMMUNICATION ERROR	—	<ul style="list-style-type: none"> The menu appears on the operation display on the printer. →Press the MENU button on the printer to retrieve the Ready display.

