

SONY

Model: KDL-32BX320

Description: LCD TV
Dimensions: 31½" 20¾" 8⅝"
(WHD): 31½" 19½" 3⅝" w/o stand
Weight: 28.7 lb

Carton Dimensions: tbd
(WHD):
Power 120V AC
requirements: 60HZ

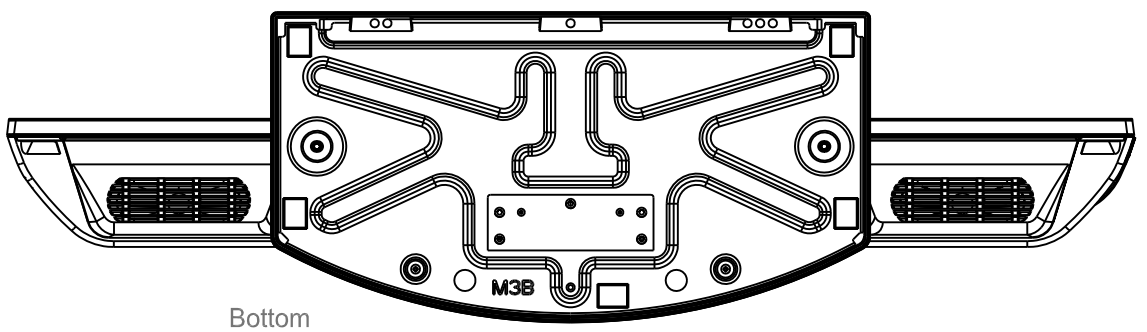
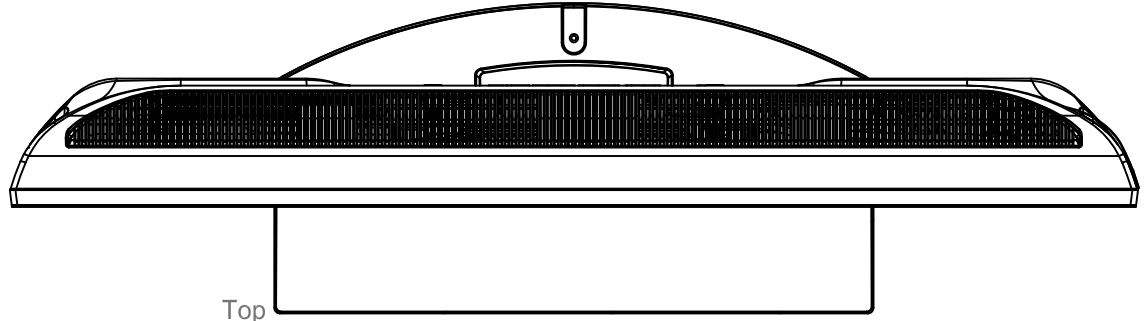
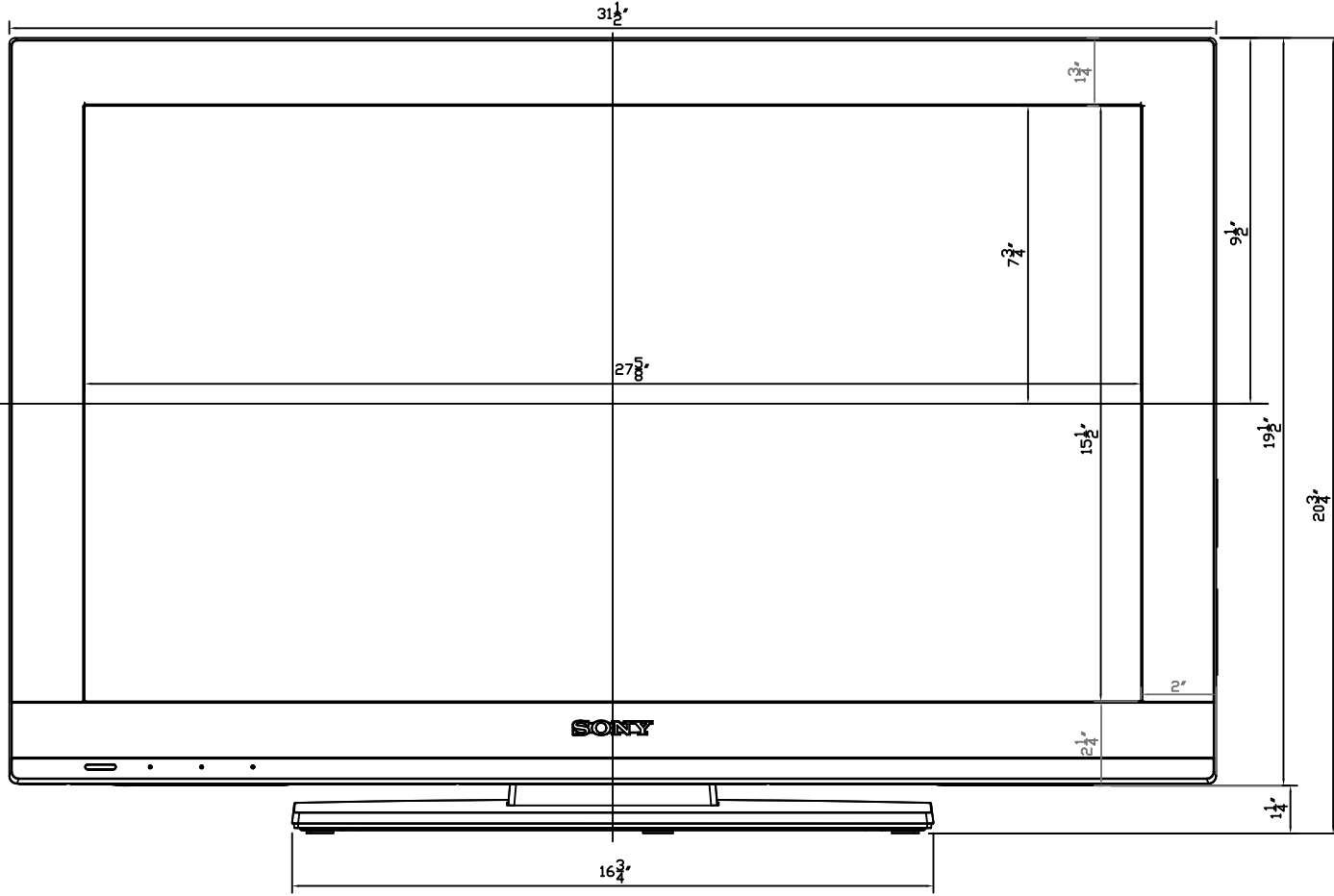

NOTE:
WHERE THERE ARE CLOSE TOLERANCES INVOLVED IN CABINET BUILDING OR APPLICATIONS WHICH REQUIRE A GREAT DEGREE OF PRECISION, WE RECOMMEND THAT THE PRODUCT ITSELF BE USED TO MAKE THE ACTUAL MEASUREMENTS. SONY WILL NOT BE HELD RESPONSIBLE FOR INACCURACIES IN THE DESIGN OR MANUFACTURE OF ENCLOSURES.

SONY

Model: KDL-32BX320

Description: LCD TV
Dimensions: 31½" 20¾" 8½"
(WHD): 31½" 19½" 38" w/o stand
Weight: 28.7 lb

Carton Dimensions: tbd
(WHD):
Power 120V AC
requirements: 60HZ

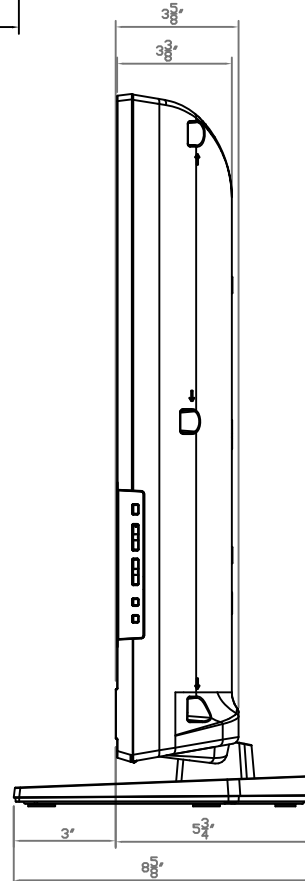
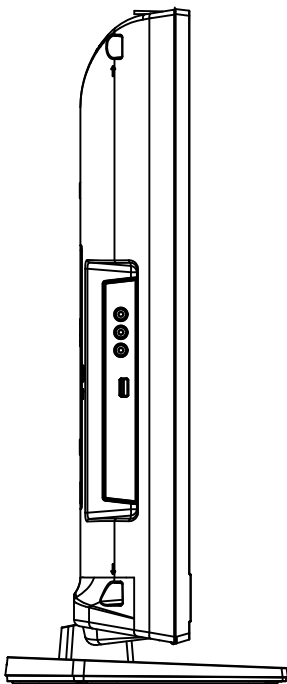
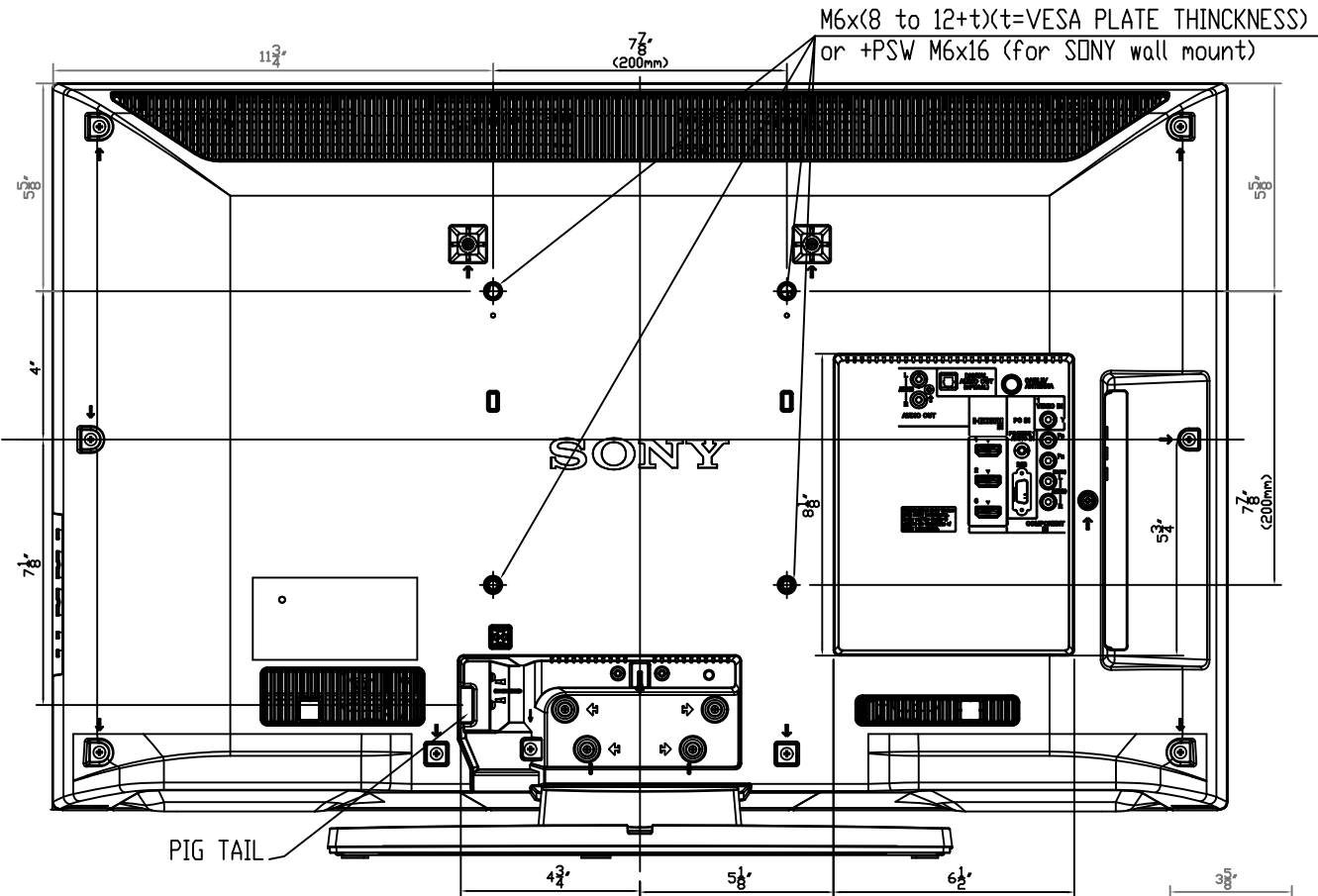

NOTE:

WHERE THERE ARE CLOSE TOLERANCES INVOLVED IN CABINET BUILDING OR APPLICATIONS WHICH REQUIRE A GREAT DEGREE OF PRECISION, WE RECOMMEND THAT THE PRODUCT ITSELF BE USED TO MAKE THE ACTUAL MEASUREMENTS. SONY WILL NOT BE HELD RESPONSIBLE FOR INACCURACIES IN THE DESIGN OR MANUFACTURE OF ENCLOSURES.

SONY

Model: KDL-32BX320

Description: LCD TV
Dimensions: 31½" 20¾" 8⅝"
(WHD): 31½" 19½" 3⅝" w/o stand
Weight: 28.7 lb

Carton Dimensions: tbd
(WHD):
Power 120V AC
requirements: 60HZ

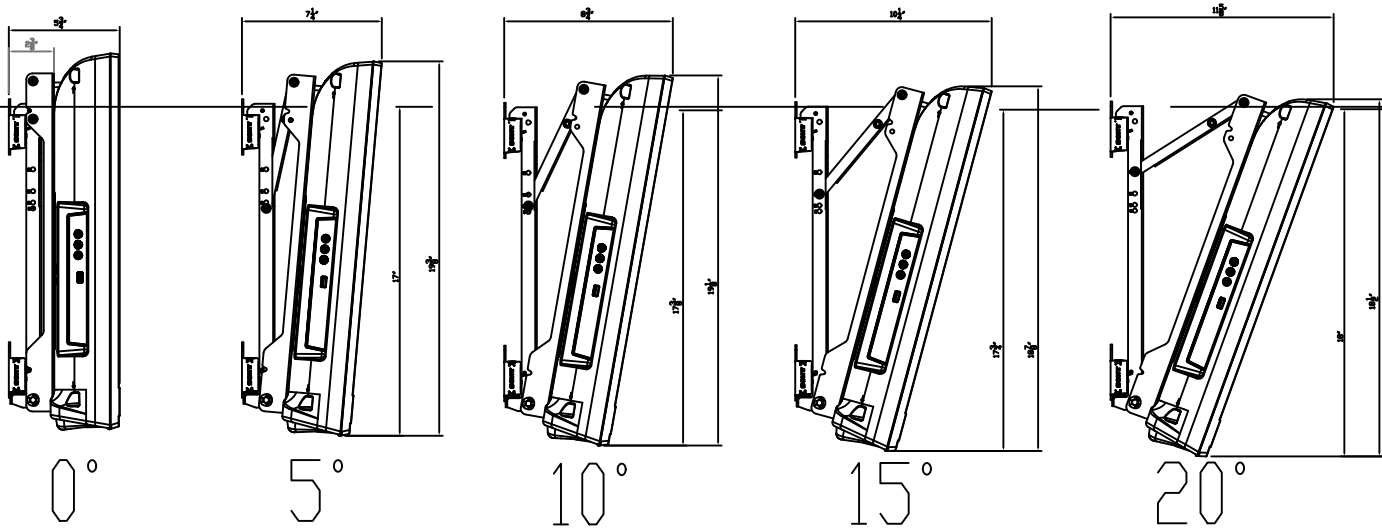
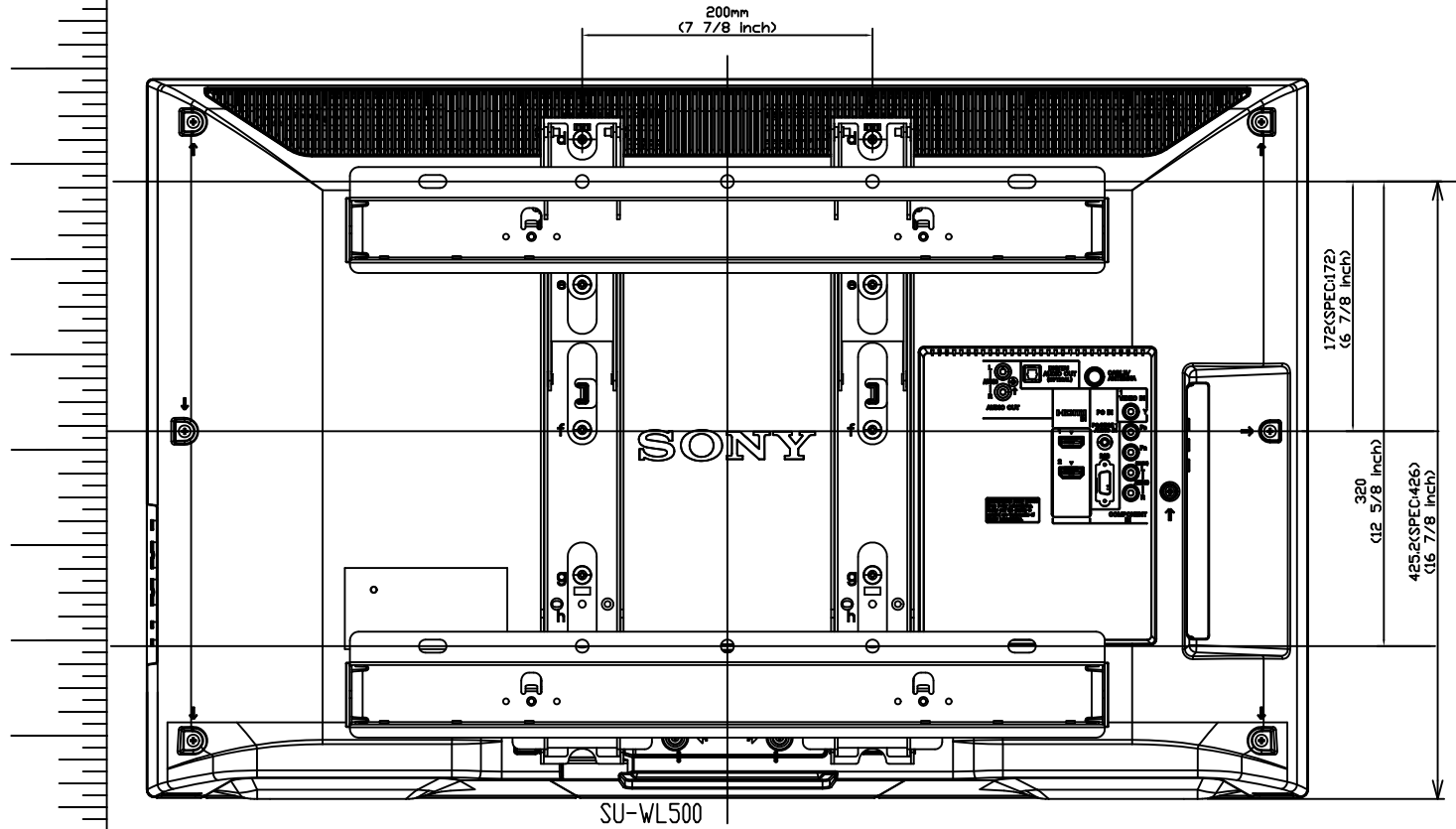

NOTE:
WHERE THERE ARE CLOSE TOLERANCES INVOLVED IN CABINET BUILDING OR APPLICATIONS WHICH REQUIRE A GREAT DEGREE OF PRECISION, WE RECOMMEND THAT THE PRODUCT ITSELF BE USED TO MAKE THE ACTUAL MEASUREMENTS. SONY WILL NOT BE HELD RESPONSIBLE FOR INACCURACIES IN THE DESIGN OR MANUFACTURE OF ENCLOSURES.