

SONY

Model: KDL-32LL150

Description: LCD TV  
Dimensions: 31 $\frac{5}{8}$ " 21 $\frac{7}{8}$ " 8 $\frac{3}{4}$ "  
(WHD): 31 $\frac{5}{8}$ " 19 $\frac{7}{8}$ " 3 $\frac{5}{8}$ " w/o stand  
Weight: 28 lb

Carton Dimensions: 38 $\frac{3}{4}$ " 24 $\frac{1}{8}$ " 7 $\frac{7}{8}$ "  
(WHD):

Power 120V AC  
requirements: 60HZ

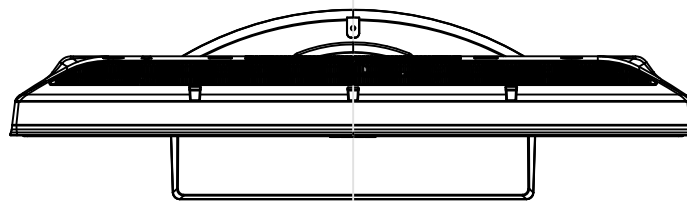
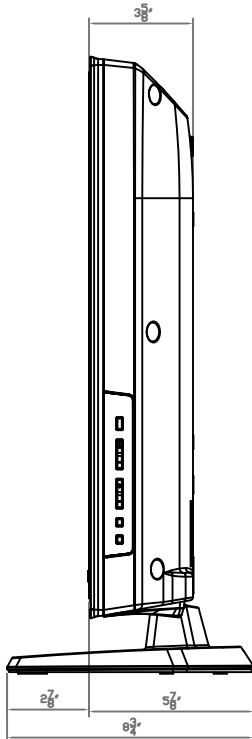
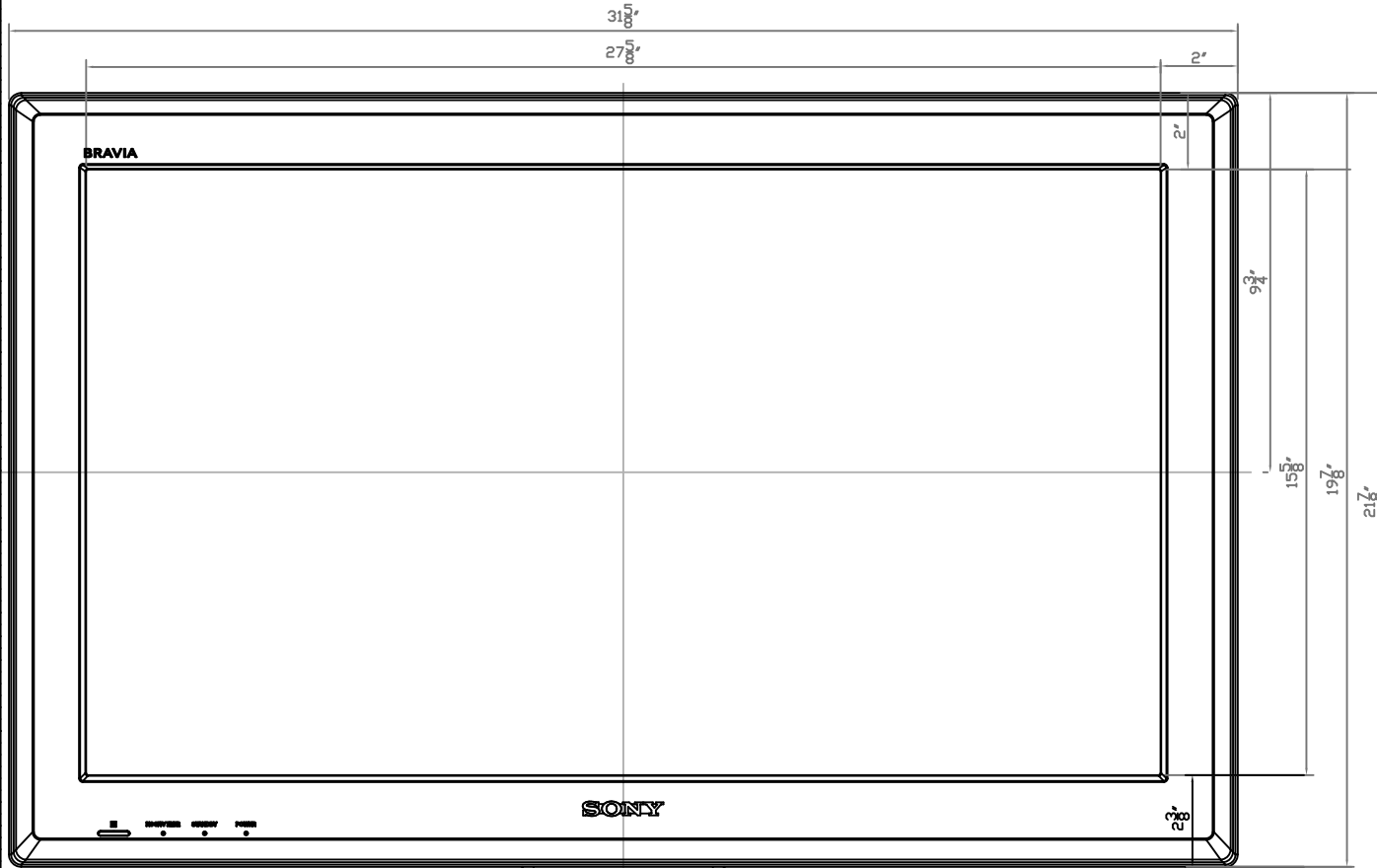

Top

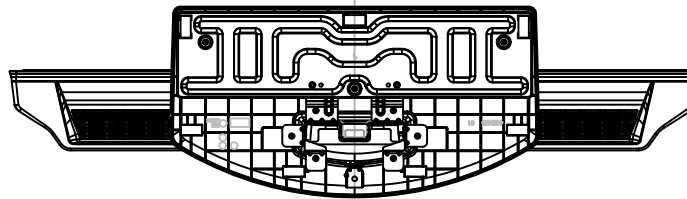

Bottom

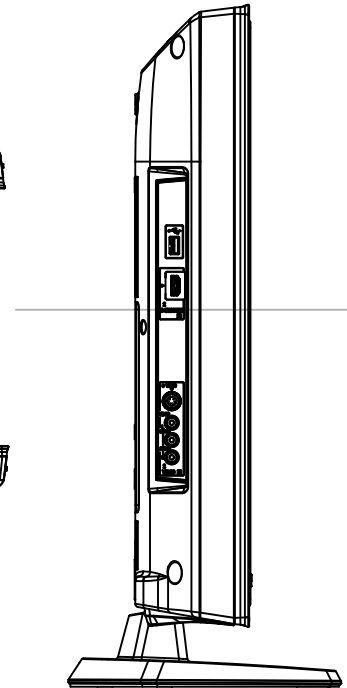

NOTE:

WHERE THERE ARE CLOSE TOLERANCES INVOLVED IN CABINET BUILDING OR APPLICATIONS WHICH REQUIRE A GREAT DEGREE OF PRECISION, WE RECOMMEND THAT THE PRODUCT ITSELF BE USED TO MAKE THE ACTUAL MEASUREMENTS. SONY WILL NOT BE HELD RESPONSIBLE FOR INACCURACIES IN THE DESIGN OR MANUFACTURE OF ENCLOSURES.

Consumer Integrated Systems - Park Ridge, New Jersey 07656 - Fax (201)930-7891 - [www.sony.com/dn](http://www.sony.com/dn)

Features and specifications subject to change without notice. Non-Metric weights and measurements are approximate.

SONY

Model: KDL-32LL150

Description: LCD TV  
Dimensions: 31 $\frac{5}{8}$ " 21 $\frac{7}{8}$ " 8 $\frac{3}{4}$ "  
(WHD): 31 $\frac{5}{8}$ " 19 $\frac{7}{8}$ " 3 $\frac{5}{8}$ " w/o stand

Weight: 28 lb

Carton Dimensions: 38 $\frac{3}{4}$ " 24 $\frac{1}{8}$ " 7 $\frac{7}{8}$ "  
(WHD):

Power requirements: 120V AC  
60HZ

M6x(8 to 12+t) (t: VESA PLATE THICKNESS)  
or +PSW6x16 (for SONY wall mount)

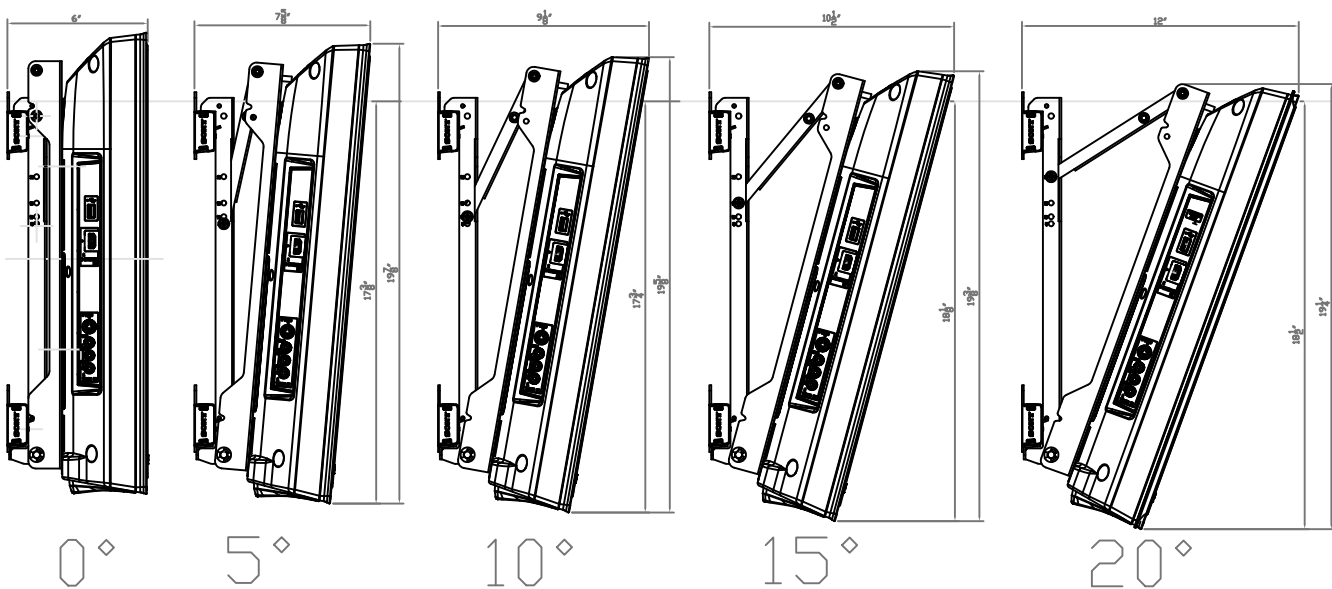
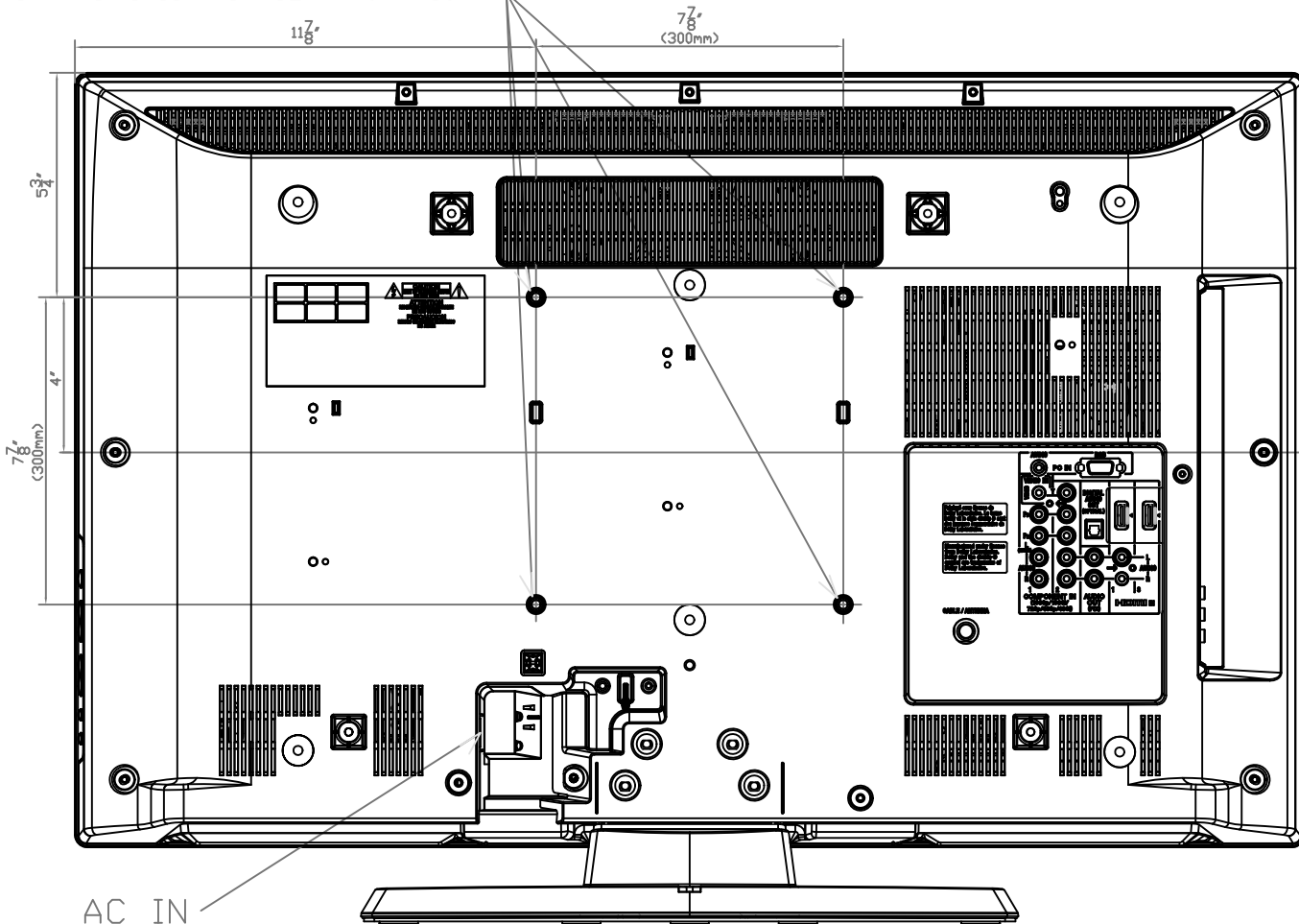

NOTE:

WHERE THERE ARE CLOSE TOLERANCES INVOLVED IN CABINET BUILDING OR APPLICATIONS WHICH REQUIRE A GREAT DEGREE OF PRECISION, WE RECOMMEND THAT THE PRODUCT ITSELF BE USED TO MAKE THE ACTUAL MEASUREMENTS. SONY WILL NOT BE HELD RESPONSIBLE FOR INACCURACIES IN THE DESIGN OR MANUFACTURE OF ENCLOSURES.

Consumer Integrated Systems - Park Ridge, New Jersey 07656 - Fax (201)930-7891 - [www.sony.com/dn](http://www.sony.com/dn)

Features and specifications subject to change without notice. Non-Metric weights and measurements are approximate.