

[▶ Troubleshooting](#)**How to Use**

What You Can Do

Parts Description

Setup

Enjoying Music

Enjoying Videos / Photos

Application

Android

Connections

Settings

Other Operations

Notifications

Announcements

NWZ-Z1040/Z1050/Z1060

Use this manual if you encounter any problems, or have any questions about your "WALKMAN."

[Read This First](#)



[▶ Troubleshooting](#)

How to Use

What You Can Do

Parts Description

Setup

Enjoying Music

Enjoying Videos / Photos

Application

Android

Connections

Settings

Other Operations

Notifications

Announcements

What You Can Do

[Bluetooth](#)

[FM radio](#)

[HDMI](#)

[Home](#)

[Music player](#)

[Preinstalled applications](#)

[USB](#)

[Wi-Fi](#)

[DLNA](#)

[GPS](#)

[Help guide](#)

[Media Go](#)

[Photo viewer](#)

[SensMe™ channels](#)

[Video player](#)

[Wi-Fi checker](#)



[▶ Troubleshooting](#)

How to Use

What You Can Do

Parts Description

Setup

Enjoying Music

Enjoying Videos / Photos

Application

Android

Connections

Settings

Other Operations

Notifications

Announcements

Parts Description

[Home/Menu/Back button](#)

[Reset button](#)

[W. button](#)

[Power button](#)

[Volume](#)

[Walkman](#)

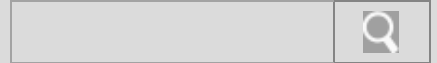

[▶ Troubleshooting](#)

How to Use

What You Can Do

Parts Description

Setup

Enjoying Music

Enjoying Videos / Photos

Application

Android

Connections

Settings

Other Operations

Notifications

Announcements

Setup

[Charging/battery](#)

[Google account](#)

[Power button](#)

[Earbuds](#)

[Help guide](#)

[Supplied software](#)



[▶ Troubleshooting](#)

How to Use

What You Can Do

Parts Description

Setup

Enjoying Music

Enjoying Videos / Photos

Application

Android

Connections

Settings

Other Operations

Notifications

Announcements

Enjoying Music

[Media Go](#)

[Music player](#)

[SensMe™ channels](#)

[W. button](#)

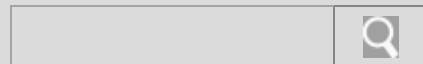

[▶ Troubleshooting](#)

How to Use

What You Can Do

Parts Description

Setup

Enjoying Music

Enjoying Videos / Photos

Application

Android

Connections

Settings

Other Operations

Notifications

Announcements

Enjoying Videos / Photos

[Media Go](#)

[Photo viewer](#)

[Video player](#)



▶ Troubleshooting

How to Use

What You Can Do

Parts Description

Setup

Enjoying Music

Enjoying Videos / Photos

Application

Android

Connections

Settings

Other Operations

Notifications

Announcements

Application

[DLNA](#)

[Help guide](#)

[Preinstalled applications](#)

[Wi-Fi checker](#)

[FM radio](#)

[Original apps](#)

[Wi-Fi](#)



[▶ Troubleshooting](#)

How to Use

What You Can Do

Parts Description

Setup

Enjoying Music

Enjoying Videos / Photos

Application

Android

Connections

Settings

Other Operations

Notifications

Announcements

Android

[Favorites](#)

[Google account](#)

[Home/Menu/Back button](#)

[System](#)

[Volume](#)

[General](#)

[Home](#)

[Language](#)

[Touch screen](#)



[▶ Troubleshooting](#)

How to Use

What You Can Do

Parts Description

Setup

Enjoying Music

Enjoying Videos / Photos

Application

Android

Connections

Settings

Other Operations

Notifications

Announcements

Connections

[Bluetooth](#)

[HDMI](#)

[USB](#)

[Wi-Fi](#)

[Wi-Fi checker](#)



▶ Troubleshooting

How to Use

What You Can Do

Parts Description

Setup

Enjoying Music

Enjoying Videos / Photos

Application

Android

Connections

Settings

Other Operations

Notifications

Announcements

Settings

[AVLS \(Volume Limit\)](#)

[FM radio](#)

[GPS](#)

[Google account](#)

[Music player](#)

[Power button](#)

[Video player](#)

[Wi-Fi](#)

[Bluetooth](#)

[Favorites](#)

[General](#)

[Home](#)

[Photo viewer](#)

[System](#)

[Volume](#)

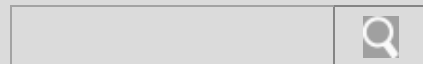

[▶ Troubleshooting](#)

How to Use

What You Can Do

Parts Description

Setup

Enjoying Music

Enjoying Videos / Photos

Application

Android

Connections

Settings

Other Operations

Notifications

Announcements

Other Operations

[GPS](#)

[Reset button](#)

[Microphone](#)

[Speaker](#)



[▶ Troubleshooting](#)

How to Use

What You Can Do

Parts Description

Setup

Enjoying Music

Enjoying Videos / Photos

Application

Android

Connections

Settings

Other Operations

Notifications

Announcements

Notifications

[License/trademarks](#)

[▶ Troubleshooting](#)**How to Use**

What You Can Do

Parts Description

Setup

Enjoying Music

Enjoying Videos / Photos

Application

Android

Connections

Settings

Other Operations

Notifications

Announcements**Announcements**[Important product information](#)[Maintenance](#)[Recordable files](#)[Specifications](#)[Supported formats](#)[Touch screen](#)[License/trademarks](#)[Manual](#)[Sample data](#)[Support website](#)[System requirements](#)

[▶ How to Use](#)**Troubleshooting**

General

Music

Video / Photo

Apps

Supplied Software

NWZ-Z1040/Z1050/Z1060

Use this manual if you encounter any problems, or have any questions about your "WALKMAN."



[▶ Troubleshooting](#)**How to Use****What You Can Do****Parts Description****Setup****Enjoying Music****Enjoying Videos / Photos****Application****Android****Connections****Settings****Other Operations****Notifications****Announcements****About the "WALKMAN" manuals**

Operation of this "WALKMAN" is explained in the following manuals.

Quick Start Guide (supplied)

This covers topics such as initial settings, basic operations, how to install the supplied software, how to install and use the Help guide, etc.

Help guide (for viewing on your "WALKMAN" screen)

This is factory-preinstalled on your "WALKMAN." It can be viewed from a bookmark in the browser. [\[Details\]](#)

The Help guide covers items such as descriptions of "WALKMAN" operations and applications.

The Help guide for viewing on your "WALKMAN" screen is provided only in some languages.

Help guide (for viewing on a computer screen)

This is factory-preinstalled on your "WALKMAN." Install it on a computer and view with WALKMAN Guide. [\[Details\]](#) For details on installing, refer to the supplied "Quick Start Guide."

The Help guide covers items such as descriptions of "WALKMAN" operations and applications.

Hint

- The content of the Help guide for viewing on your "WALKMAN" screen and for viewing on a computer screen are the same.

[▶ Troubleshooting](#)

How to Use

What You Can Do**Parts Description****Setup****Enjoying Music****Enjoying Videos / Photos****Application****Android****Connections****Settings****Other Operations****Notifications****Announcements****Bluetooth**[About the Bluetooth function](#)**You might be looking for the following topics:**[Connecting with a Bluetooth device](#)[Disconnecting from a Bluetooth device](#)[Enabling other Bluetooth devices to discover your "WALKMAN"](#)[Notes on the Bluetooth function](#)[Pairing \(registering\) with a Bluetooth device](#)[Turning the Bluetooth function on and off](#)[Unpairing from a Bluetooth device](#)

[▶ Troubleshooting](#)

How to Use

What You Can Do**Parts Description****Setup****Enjoying Music****Enjoying Videos / Photos****Application****Android****Connections****Settings****Other Operations****Notifications****Announcements****FM radio**[About FM radio](#)**You might be looking for the following topics:**[Deleting preset stations](#)[How to use the FM radio screen](#)[Listening to FM radio](#)[Presetting stations automatically \(auto preset\)](#)[Presetting stations manually](#)[Setting FM radio to monaural/stereo](#)[Setting the FM radio scan sensitivity](#)

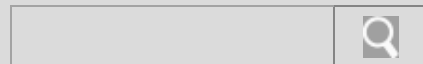

[▶ Troubleshooting](#)

How to Use

What You Can Do

Parts Description

Setup

Enjoying Music

Enjoying Videos / Photos

Application

Android

Connections

Settings

Other Operations

Notifications

Announcements

HDMI

[About HDMI](#)

You might be looking for the following topics:

[Connecting by HDMI](#)



▶ Troubleshooting

How to Use

What You Can Do

Parts Description

Setup

Enjoying Music

Enjoying Videos / Photos

Application

Android

Connections

Settings

Other Operations

Notifications

Announcements

Home

[Home screen](#)

You might be looking for the following topics:

[About notification panel](#)

[Editing Favorites](#)

[Main notification icons](#)

[Using Favorites](#)

[▶ Troubleshooting](#)

How to Use

What You Can Do**Parts Description****Setup****Enjoying Music****Enjoying Videos / Photos****Application****Android****Connections****Settings****Other Operations****Notifications****Announcements****Music player**[About Music player](#)**You might be looking for the following topics:**[Changing music settings](#)[Deleting songs](#)[How to use the music playback screen](#)[Playing music](#)[Playing songs in playlists](#)[Selecting an album by cover art](#)[Selecting songs from the library](#)[Switching the information area display](#)[Using the Visualizer](#)[Using the mini player](#)

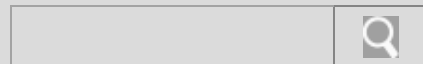

[▶ Troubleshooting](#)

How to Use

What You Can Do

Parts Description

Setup

Enjoying Music

Enjoying Videos / Photos

Application

Android

Connections

Settings

Other Operations

Notifications

Announcements

Preinstalled applications

[Preinstalled applications](#)

[▶ Troubleshooting](#)

How to Use

What You Can Do**Parts Description****Setup****Enjoying Music****Enjoying Videos / Photos****Application****Android****Connections****Settings****Other Operations****Notifications****Announcements****USB**[About USB connection](#)**You might be looking for the following topics:**[Connecting by USB](#)[Disconnecting USB cable](#)[Dragging and dropping data to a computer with USB connection](#)[Notes on USB connection](#)

[▶ Troubleshooting](#)

How to Use

What You Can Do**Parts Description****Setup****Enjoying Music****Enjoying Videos / Photos****Application****Android****Connections****Settings****Other Operations****Notifications****Announcements****Wi-Fi**[About Wi-Fi checker](#)[About Wi-Fi communications](#)**You might be looking for the following topics:**[Adding Wi-Fi networks manually](#)[Checking Wi-Fi network status](#)[Connecting to a Wi-Fi network](#)[Notes on Wi-Fi](#)[Turning Wi-Fi on and off](#)

[▶ Troubleshooting](#)

How to Use

What You Can Do**Parts Description****Setup****Enjoying Music****Enjoying Videos / Photos****Application****Android****Connections****Settings****Other Operations****Notifications****Announcements****DLNA**[About DLNA](#)**You might be looking for the following topics:**[Connecting DLNA devices](#)[Playing back content stored on another device](#)[Sending content to other devices and playing it back](#)

[▶ Troubleshooting](#)

How to Use

What You Can Do**Parts Description****Setup****Enjoying Music****Enjoying Videos / Photos****Application****Android****Connections****Settings****Other Operations****Notifications****Announcements****GPS**[About the location information](#)**You might be looking for the following topics:**[Enabling/disabling use of location information](#)[Notes on the GPS function](#)[Setting to search for your current position with a wireless network](#)



[▶ Troubleshooting](#)

How to Use

What You Can Do

Parts Description

Setup

Enjoying Music

Enjoying Videos / Photos

Application

Android

Connections

Settings

Other Operations

Notifications

Announcements

Help guide

[About the Help guide](#)

You might be looking for the following topics:

[Starting the Help guide on a computer](#)

[Starting the Help guide on your "WALKMAN"](#)

[▶ Troubleshooting](#)

How to Use

What You Can Do**Parts Description****Setup****Enjoying Music****Enjoying Videos / Photos****Application****Android****Connections****Settings****Other Operations****Notifications****Announcements****Media Go**[About Media Go](#)**You might be looking for the following topics:**[Importing music from CDs using Media Go](#)[Transferring content using Media Go](#)

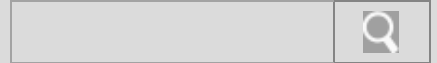

[▶ Troubleshooting](#)

How to Use

What You Can Do

Parts Description

Setup

Enjoying Music

Enjoying Videos / Photos

Application

Android

Connections

Settings

Other Operations

Notifications

Announcements

Photo viewer

[About Photo viewer](#)

You might be looking for the following topics:

[Adding tags to photos](#)

[Changing Photo viewer settings](#)

[Deleting photos](#)

[How to use the photo screen](#)

[Viewing photos](#)

[▶ Troubleshooting](#)

How to Use

What You Can Do**Parts Description****Setup****Enjoying Music****Enjoying Videos / Photos****Application****Android****Connections****Settings****Other Operations****Notifications****Announcements****SensMe™ channels**[About SensMe™ channels](#)**You might be looking for the following topics:**[Analyzing songs on your "WALKMAN"](#)[Playing songs using SensMe™ channels](#)



[▶ Troubleshooting](#)

How to Use

What You Can Do

Parts Description

Setup

Enjoying Music

Enjoying Videos / Photos

Application

Android

Connections

Settings

Other Operations

Notifications

Announcements

Video player

[About Video player](#)

You might be looking for the following topics:

[Changing Video player settings](#)

[Deleting videos](#)

[Finding scenes from video thumbnails](#)

[How to use the video playback screen](#)

[Playing back videos](#)

[Selecting videos](#)

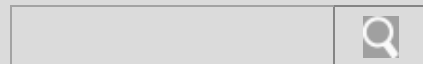

[▶ Troubleshooting](#)

How to Use

What You Can Do

Parts Description

Setup

Enjoying Music

Enjoying Videos / Photos

Application

Android

Connections

Settings

Other Operations

Notifications

Announcements

Wi-Fi checker

[About Wi-Fi checker](#)



[▶ Troubleshooting](#)

How to Use

What You Can Do

Parts Description

Setup

Enjoying Music

Enjoying Videos / Photos

Application

Android

Connections

Settings

Other Operations

Notifications

Announcements

Home/Menu/Back button

[Using the Home, Menu, and Back buttons](#)

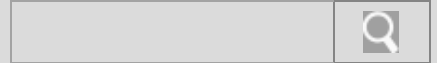

[▶ Troubleshooting](#)

How to Use

What You Can Do

Parts Description

Setup

Enjoying Music

Enjoying Videos / Photos

Application

Android

Connections

Settings

Other Operations

Notifications

Announcements

Reset button

[Resetting](#)

[▶ Troubleshooting](#)**How to Use**

What You Can Do**Parts Description****Setup**

Enjoying Music

Enjoying Videos / Photos

Application

Android

Connections

Settings

Other Operations

Notifications

Announcements

W. button[Using the W.button](#)**You might be looking for the following topics:**[How to use the W.control](#)[Setting the W.control](#)



[▶ Troubleshooting](#)

How to Use

What You Can Do

Parts Description

Setup

Enjoying Music

Enjoying Videos / Photos

Application

Android

Connections

Settings

Other Operations

Notifications

Announcements

Power button

[Turning off the power](#)

[Turning on the power](#)

You might be looking for the following topics:

[Turning the screen on and off](#)

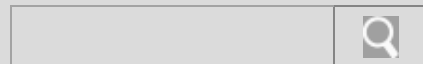

[▶ Troubleshooting](#)

How to Use

What You Can Do

Parts Description

Setup

Enjoying Music

Enjoying Videos / Photos

Application

Android

Connections

Settings

Other Operations

Notifications

Announcements

Volume

[Adjusting the volume](#)

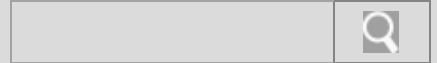

[▶ Troubleshooting](#)

How to Use

What You Can Do

Parts Description

Setup

Enjoying Music

Enjoying Videos / Photos

Application

Android

Connections

Settings

Other Operations

Notifications

Announcements

Walkman

[Parts and controls](#)



[▶ Troubleshooting](#)

How to Use

What You Can Do

Parts Description

Setup

Enjoying Music

Enjoying Videos / Photos

Application

Android

Connections

Settings

Other Operations

Notifications

Announcements

Charging/battery

[About battery life](#)

[Charging the battery](#)

[Extending the battery life](#)

[Notes on charging the battery](#)

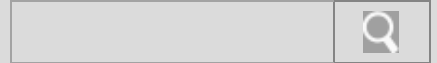

[▶ Troubleshooting](#)

How to Use

What You Can Do

Parts Description

Setup

Enjoying Music

Enjoying Videos / Photos

Application

Android

Connections

Settings

Other Operations

Notifications

Announcements

Google account

[Deleting a Google account](#)

[Setting a Google account](#)

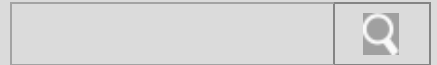

[▶ Troubleshooting](#)

How to Use

What You Can Do

Parts Description

Setup

Enjoying Music

Enjoying Videos / Photos

Application

Android

Connections

Settings

Other Operations

Notifications

Announcements

Power button

[Turning off the power](#)

[Turning on the power](#)

[Turning the screen on and off](#)

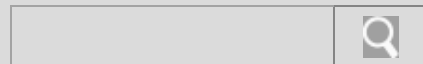

[▶ Troubleshooting](#)

How to Use

What You Can Do

Parts Description

Setup

Enjoying Music

Enjoying Videos / Photos

Application

Android

Connections

Settings

Other Operations

Notifications

Announcements

Earbuds

[Replacing the headphone earbuds](#)



[▶ Troubleshooting](#)

How to Use

What You Can Do

Parts Description

Setup

Enjoying Music

Enjoying Videos / Photos

Application

Android

Connections

Settings

Other Operations

Notifications

Announcements

Help guide

[About the Help guide](#)

[Starting the Help guide on a computer](#)

[Starting the Help guide on your "WALKMAN"](#)



[▶ Troubleshooting](#)

How to Use

What You Can Do

Parts Description

Setup

Enjoying Music

Enjoying Videos / Photos

Application

Android

Connections

Settings

Other Operations

Notifications

Announcements

Supplied software

[Notes on the supplied software](#)

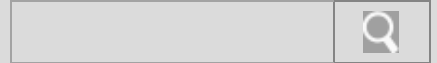

[▶ Troubleshooting](#)

How to Use

What You Can Do

Parts Description

Setup

Enjoying Music

Enjoying Videos / Photos

Application

Android

Connections

Settings

Other Operations

Notifications

Announcements

Media Go

[About Media Go](#)

[Importing music from CDs using Media Go](#)

[Transferring content using Media Go](#)



[▶ Troubleshooting](#)

How to Use

What You Can Do

Parts Description

Setup

Enjoying Music

Enjoying Videos / Photos

Application

Android

Connections

Settings

Other Operations

Notifications

Announcements

SensMe™ channels

[About SensMe™ channels](#)

[Analyzing songs on your “WALKMAN”](#)

[Playing songs using SensMe™ channels](#)

[▶ Troubleshooting](#)

How to Use

What You Can Do

Parts Description

Setup

Enjoying Music

Enjoying Videos / Photos

Application

Android

Connections

Settings

Other Operations

Notifications

Announcements

Music player[About Music player](#)[Changing music settings](#)[Deleting songs](#)[How to use the music playback screen](#)[Playing music](#)[Playing songs in playlists](#)[Selecting an album by cover art](#)[Selecting songs from the library](#)[Switching the information area display](#)[Using the Visualizer](#)[Using the mini player](#)

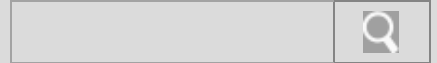

[▶ Troubleshooting](#)

How to Use

What You Can Do

Parts Description

Setup

Enjoying Music

Enjoying Videos / Photos

Application

Android

Connections

Settings

Other Operations

Notifications

Announcements

W. button

[How to use the W.control](#)

[Setting the W.control](#)

[Using the W.button](#)

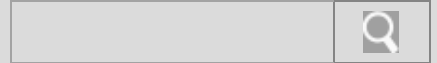

[▶ Troubleshooting](#)

How to Use

What You Can Do

Parts Description

Setup

Enjoying Music

Enjoying Videos / Photos

Application

Android

Connections

Settings

Other Operations

Notifications

Announcements

Media Go

[Transferring content using Media Go](#)

You might be looking for the following topics:

[About Media Go](#)

[Importing music from CDs using Media Go](#)



[▶ Troubleshooting](#)

How to Use

What You Can Do

Parts Description

Setup

Enjoying Music

Enjoying Videos / Photos

Application

Android

Connections

Settings

Other Operations

Notifications

Announcements

Video player

[About Video player](#)

[Changing Video player settings](#)

[Deleting videos](#)

[Finding scenes from video thumbnails](#)

[How to use the video playback screen](#)

[Playing back videos](#)

[Selecting videos](#)



[▶ Troubleshooting](#)

How to Use

What You Can Do

Parts Description

Setup

Enjoying Music

Enjoying Videos / Photos

Application

Android

Connections

Settings

Other Operations

Notifications

Announcements

Photo viewer

[About Photo viewer](#)

[Adding tags to photos](#)

[Changing Photo viewer settings](#)

[Deleting photos](#)

[How to use the photo screen](#)

[Viewing photos](#)

[▶ Troubleshooting](#)[How to Use](#)[What You Can Do](#)[Parts Description](#)[Setup](#)[Enjoying Music](#)[Enjoying Videos / Photos](#)[Application](#)[Android](#)[Connections](#)[Settings](#)[Other Operations](#)[Notifications](#)[Announcements](#)**DLNA**[About DLNA](#)[Connecting DLNA devices](#)[Playing back content stored on another device](#)[Sending content to other devices and playing it back](#)

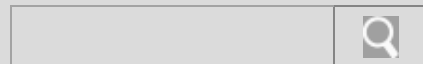

[▶ Troubleshooting](#)

How to Use

What You Can Do

Parts Description

Setup

Enjoying Music

Enjoying Videos / Photos

Application

Android

Connections

Settings

Other Operations

Notifications

Announcements

Help guide

[About the Help guide](#)

[Starting the Help guide on a computer](#)

[Starting the Help guide on your "WALKMAN"](#)



[▶ Troubleshooting](#)

How to Use

What You Can Do

Parts Description

Setup

Enjoying Music

Enjoying Videos / Photos

Application

Android

Connections

Settings

Other Operations

Notifications

Announcements

Preinstalled applications

[Preinstalled applications](#)



[▶ Troubleshooting](#)

How to Use

What You Can Do

Parts Description

Setup

Enjoying Music

Enjoying Videos / Photos

Application

Android

Connections

Settings

Other Operations

Notifications

Announcements

Wi-Fi checker

[About Wi-Fi checker](#)

[▶ Troubleshooting](#)[How to Use](#)[What You Can Do](#)[Parts Description](#)[Setup](#)[Enjoying Music](#)[Enjoying Videos / Photos](#)[Application](#)[Android](#)[Connections](#)[Settings](#)[Other Operations](#)[Notifications](#)[Announcements](#)**FM radio**[About FM radio](#)[Deleting preset stations](#)[How to use the FM radio screen](#)[Listening to FM radio](#)[Presetting stations automatically \(auto preset\)](#)[Presetting stations manually](#)[Setting FM radio to monaural/stereo](#)[Setting the FM radio scan sensitivity](#)

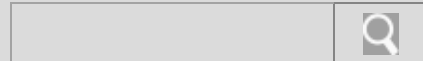

[▶ Troubleshooting](#)

How to Use

What You Can Do

Parts Description

Setup

Enjoying Music

Enjoying Videos / Photos

Application

Android

Connections

Settings

Other Operations

Notifications

Announcements

Original apps

[About Original apps](#)

[▶ Troubleshooting](#)**How to Use**[What You Can Do](#)[Parts Description](#)[Setup](#)[Enjoying Music](#)[Enjoying Videos / Photos](#)[Application](#)[Android](#)[Connections](#)[Settings](#)[Other Operations](#)[Notifications](#)[Announcements](#)**Wi-Fi**[About Wi-Fi checker](#)**You might be looking for the following topics:**[About Wi-Fi communications](#)
[Adding Wi-Fi networks manually](#)
[Checking Wi-Fi network status](#)
[Connecting to a Wi-Fi network](#)
[Notes on Wi-Fi](#)
[Turning Wi-Fi on and off](#)



[▶ Troubleshooting](#)

How to Use

What You Can Do

Parts Description

Setup

Enjoying Music

Enjoying Videos / Photos

Application

Android

Connections

Settings

Other Operations

Notifications

Announcements

Favorites

[Editing Favorites](#)

[Using Favorites](#)

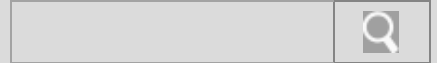

[▶ Troubleshooting](#)

How to Use

What You Can Do

Parts Description

Setup

Enjoying Music

Enjoying Videos / Photos

Application

Android

Connections

Settings

Other Operations

Notifications

Announcements

Google account

[Deleting a Google account](#)

[Setting a Google account](#)



[▶ Troubleshooting](#)

How to Use

What You Can Do

Parts Description

Setup

Enjoying Music

Enjoying Videos / Photos

Application

Android

Connections

Settings

Other Operations

Notifications

Announcements

Home/Menu/Back button

[Using the Home, Menu, and Back buttons](#)

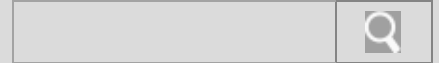

[▶ Troubleshooting](#)

How to Use

What You Can Do

Parts Description

Setup

Enjoying Music

Enjoying Videos / Photos

Application

Android

Connections

Settings

Other Operations

Notifications

Announcements

System

[Initializing](#)

[Updating the system](#)



[▶ Troubleshooting](#)

How to Use

[What You Can Do](#)

[Parts Description](#)

[Setup](#)

[Enjoying Music](#)

[Enjoying Videos / Photos](#)

[Application](#)

[Android](#)

[Connections](#)

[Settings](#)

[Other Operations](#)

[Notifications](#)

[Announcements](#)

Volume

[Adjusting the volume](#)



[▶ Troubleshooting](#)

How to Use

What You Can Do

Parts Description

Setup

Enjoying Music

Enjoying Videos / Photos

Application

Android

Connections

Settings

Other Operations

Notifications

Announcements

General

[Changing the settings](#)

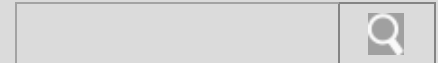

NWZ-Z1040/Z1050/Z1060

[Back](#) | [Back to Top](#)

▶ Troubleshooting

How to Use

What You Can Do

Parts Description

Setup

Enjoying Music

Enjoying Videos / Photos

Application

Android

Connections

Settings

Other Operations

Notifications

Announcements

Home

[About notification panel](#)

[Editing Favorites](#)

[Home screen](#)

[Main notification icons](#)

[Using Favorites](#)

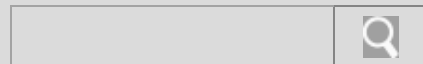

[▶ Troubleshooting](#)

How to Use

What You Can Do

Parts Description

Setup

Enjoying Music

Enjoying Videos / Photos

Application

Android

Connections

Settings

Other Operations

Notifications

Announcements

Language

[Changing the language settings](#)



[▶ Troubleshooting](#)

How to Use

What You Can Do

Parts Description

Setup

Enjoying Music

Enjoying Videos / Photos

Application

Android

Connections

Settings

Other Operations

Notifications

Announcements

Touch screen

[How to use the touch screen](#)

[Notes on the touch screen](#)

You might be looking for the following topics:

[Caring for the touch screen](#)

[▶ Troubleshooting](#)[How to Use](#)[What You Can Do](#)[Parts Description](#)[Setup](#)[Enjoying Music](#)[Enjoying Videos / Photos](#)[Application](#)[Android](#)[Connections](#)[Settings](#)[Other Operations](#)[Notifications](#)[Announcements](#)**Bluetooth**[About the Bluetooth function](#)[Connecting with a Bluetooth device](#)[Disconnecting from a Bluetooth device](#)[Enabling other Bluetooth devices to discover your "WALKMAN"](#)[Notes on the Bluetooth function](#)[Pairing \(registering\) with a Bluetooth device](#)[Turning the Bluetooth function on and off](#)[Unpairing from a Bluetooth device](#)

[▶ Troubleshooting](#)**How to Use**

What You Can Do

Parts Description

Setup

Enjoying Music

Enjoying Videos / Photos

Application

Android**Connections****Settings**

Other Operations

Notifications

Announcements

USB[About USB connection](#)[Connecting by USB](#)[Disconnecting USB cable](#)[Dragging and dropping data to a computer with USB connection](#)[Notes on USB connection](#)

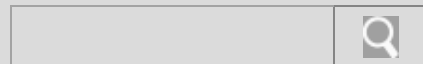

[▶ Troubleshooting](#)

How to Use

What You Can Do

Parts Description

Setup

Enjoying Music

Enjoying Videos / Photos

Application

Android

Connections

Settings

Other Operations

Notifications

Announcements

Wi-Fi checker

[About Wi-Fi checker](#)

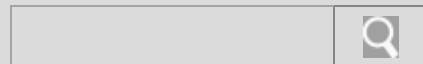

[▶ Troubleshooting](#)

How to Use

What You Can Do

Parts Description

Setup

Enjoying Music

Enjoying Videos / Photos

Application

Android

Connections

Settings

Other Operations

Notifications

Announcements

HDMI

[About HDMI](#)

[Connecting by HDMI](#)



NWZ-Z1040/Z1050/Z1060

[Back](#) | [Back to Top](#)[▶ Troubleshooting](#)**How to Use**

What You Can Do

Parts Description

Setup

Enjoying Music

Enjoying Videos / Photos

Application

Android**Connections****Settings**

Other Operations

Notifications

Announcements

Wi-Fi[About Wi-Fi checker](#)[About Wi-Fi communications](#)[Adding Wi-Fi networks manually](#)[Checking Wi-Fi network status](#)[Connecting to a Wi-Fi network](#)[Notes on Wi-Fi](#)[Turning Wi-Fi on and off](#)



[▶ Troubleshooting](#)

How to Use

What You Can Do

Parts Description

Setup

Enjoying Music

Enjoying Videos / Photos

Application

Android

Connections

Settings

Other Operations

Notifications

Announcements

AVLS (Volume Limit)

[Limiting the volume \[AVLS \(Volume Limit\)\]](#)

[▶ Troubleshooting](#)**How to Use**

What You Can Do

Parts Description

Setup

Enjoying Music

Enjoying Videos / Photos

Application

Android

Connections

Settings

Other Operations

Notifications

Announcements

FM radio[Setting FM radio to monaural/stereo](#)[Setting the FM radio scan sensitivity](#)**You might be looking for the following topics:**[About FM radio](#)[Deleting preset stations](#)[How to use the FM radio screen](#)[Listening to FM radio](#)[Presetting stations automatically \(auto preset\)](#)[Presetting stations manually](#)

[▶ Troubleshooting](#)**How to Use**

What You Can Do

Parts Description

Setup

Enjoying Music

Enjoying Videos / Photos

Application

Android

Connections

Settings

Other Operations

Notifications

Announcements

GPS[Enabling/disabling use of location information](#)[Notes on the GPS function](#)[Setting to search for your current position with a wireless network](#)**You might be looking for the following topics:**[About the location information](#)

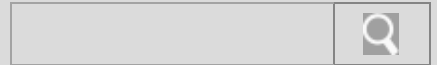

[▶ Troubleshooting](#)

How to Use

What You Can Do

Parts Description

Setup

Enjoying Music

Enjoying Videos / Photos

Application

Android

Connections

Settings

Other Operations

Notifications

Announcements

Google account

[Setting a Google account](#)

You might be looking for the following topics:

[Deleting a Google account](#)

[▶ Troubleshooting](#)**How to Use**[What You Can Do](#)[Parts Description](#)[Setup](#)[Enjoying Music](#)[Enjoying Videos / Photos](#)[Application](#)[Android](#)[Connections](#)[Settings](#)[Other Operations](#)[Notifications](#)[Announcements](#)**Music player**[Changing music settings](#)**You might be looking for the following topics:**[About Music player](#)[Deleting songs](#)[How to use the music playback screen](#)[Playing music](#)[Playing songs in playlists](#)[Selecting an album by cover art](#)[Selecting songs from the library](#)[Switching the information area display](#)[Using the Visualizer](#)[Using the mini player](#)

[▶ Troubleshooting](#)**How to Use**

What You Can Do

Parts Description

Setup

Enjoying Music

Enjoying Videos / Photos

Application

Android

Connections

Settings

Other Operations

Notifications

Announcements

Power button[Turning the screen on and off](#)**You might be looking for the following topics:**[Turning off the power](#)[Turning on the power](#)



[▶ Troubleshooting](#)

How to Use

What You Can Do

Parts Description

Setup

Enjoying Music

Enjoying Videos / Photos

Application

Android

Connections

Settings

Other Operations

Notifications

Announcements

Video player

[Changing Video player settings](#)

You might be looking for the following topics:

[About Video player](#)

[Deleting videos](#)

[Finding scenes from video thumbnails](#)

[How to use the video playback screen](#)

[Playing back videos](#)

[Selecting videos](#)

[▶ Troubleshooting](#)**How to Use**

What You Can Do

Parts Description

Setup

Enjoying Music

Enjoying Videos / Photos

Application

Android

Connections

Settings

Other Operations

Notifications

Announcements

Wi-Fi[Adding Wi-Fi networks manually](#)[Checking Wi-Fi network status](#)[Connecting to a Wi-Fi network](#)[Notes on Wi-Fi](#)[Turning Wi-Fi on and off](#)**You might be looking for the following topics:**[About Wi-Fi checker](#)[About Wi-Fi communications](#)

[▶ Troubleshooting](#)**How to Use**[What You Can Do](#)[Parts Description](#)[Setup](#)[Enjoying Music](#)[Enjoying Videos / Photos](#)[Application](#)[Android](#)[Connections](#)[Settings](#)[Other Operations](#)[Notifications](#)[Announcements](#)**Bluetooth**[Connecting with a Bluetooth device](#)[Disconnecting from a Bluetooth device](#)[Enabling other Bluetooth devices to discover your "WALKMAN"](#)[Notes on the Bluetooth function](#)[Pairing \(registering\) with a Bluetooth device](#)[Turning the Bluetooth function on and off](#)[Unpairing from a Bluetooth device](#)**You might be looking for the following topics:**[About the Bluetooth function](#)

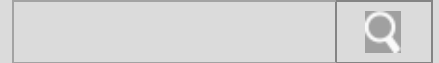

[▶ Troubleshooting](#)

How to Use

What You Can Do

Parts Description

Setup

Enjoying Music

Enjoying Videos / Photos

Application

Android

Connections

Settings

Other Operations

Notifications

Announcements

Favorites

[Editing Favorites](#)

You might be looking for the following topics:

[Using Favorites](#)



[▶ Troubleshooting](#)

How to Use

What You Can Do

Parts Description

Setup

Enjoying Music

Enjoying Videos / Photos

Application

Android

Connections

Settings

Other Operations

Notifications

Announcements

General

[Changing the settings](#)



▶ Troubleshooting

How to Use

What You Can Do

Parts Description

Setup

Enjoying Music

Enjoying Videos / Photos

Application

Android

Connections

Settings

Other Operations

Notifications

Announcements

Home

[Editing Favorites](#)

You might be looking for the following topics:

[About notification panel](#)

[Home screen](#)

[Main notification icons](#)

[Using Favorites](#)



[▶ Troubleshooting](#)

How to Use

What You Can Do

Parts Description

Setup

Enjoying Music

Enjoying Videos / Photos

Application

Android

Connections

Settings

Other Operations

Notifications

Announcements

Photo viewer

[Changing Photo viewer settings](#)

You might be looking for the following topics:

- [About Photo viewer](#)
 - [Adding tags to photos](#)
 - [Deleting photos](#)
 - [How to use the photo screen](#)
 - [Viewing photos](#)
-

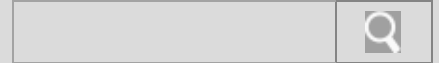

[▶ Troubleshooting](#)

How to Use

What You Can Do

Parts Description

Setup

Enjoying Music

Enjoying Videos / Photos

Application

Android

Connections

Settings

Other Operations

Notifications

Announcements

System

[Initializing](#)

[Updating the system](#)

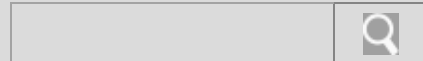

[▶ Troubleshooting](#)

How to Use

What You Can Do

Parts Description

Setup

Enjoying Music

Enjoying Videos / Photos

Application

Android

Connections

Settings

Other Operations

Notifications

Announcements

Volume

[Adjusting the volume](#)

[▶ Troubleshooting](#)**How to Use**

What You Can Do

Parts Description

Setup

Enjoying Music

Enjoying Videos / Photos

Application

Android

Connections

Settings

Other Operations

Notifications

Announcements

GPS[About the location information](#)[Enabling/disabling use of location information](#)[Notes on the GPS function](#)[Setting to search for your current position with a wireless network](#)



[▶ Troubleshooting](#)

How to Use

What You Can Do

Parts Description

Setup

Enjoying Music

Enjoying Videos / Photos

Application

Android

Connections

Settings

Other Operations

Notifications

Announcements

Reset button

[Resetting](#)



[▶ Troubleshooting](#)

How to Use

What You Can Do

Parts Description

Setup

Enjoying Music

Enjoying Videos / Photos

Application

Android

Connections

Settings

Other Operations

Notifications

Announcements

Microphone

[Using the microphone](#)

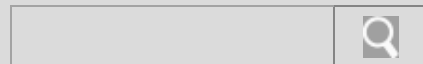

[▶ Troubleshooting](#)

How to Use

What You Can Do

Parts Description

Setup

Enjoying Music

Enjoying Videos / Photos

Application

Android

Connections

Settings

Other Operations

Notifications

Announcements

Speaker

[Using the speaker](#)

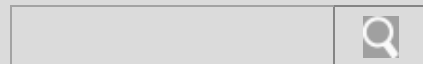

[▶ Troubleshooting](#)

How to Use

What You Can Do

Parts Description

Setup

Enjoying Music

Enjoying Videos / Photos

Application

Android

Connections

Settings

Other Operations

Notifications

Announcements

License/trademarks

[License and trademark notice](#)



[▶ Troubleshooting](#)

How to Use

What You Can Do

Parts Description

Setup

Enjoying Music

Enjoying Videos / Photos

Application

Android

Connections

Settings

Other Operations

Notifications

Announcements

Important product information

[Important product information](#)



[▶ Troubleshooting](#)

How to Use

What You Can Do

Parts Description

Setup

Enjoying Music

Enjoying Videos / Photos

Application

Android

Connections

Settings

Other Operations

Notifications

Announcements

Maintenance

[Caring for earbuds](#)

[Caring for headphone plugs](#)



[▶ Troubleshooting](#)

How to Use

What You Can Do

Parts Description

Setup

Enjoying Music

Enjoying Videos / Photos

Application

Android

Connections

Settings

Other Operations

Notifications

Announcements

Recordable files

[Maximum recordable number of photo files \(Approx.\)](#)

[Maximum recordable number of songs and time \(Approx.\)](#)

[Maximum recordable time of videos \(Approx.\)](#)



[▶ Troubleshooting](#)

How to Use

What You Can Do

Parts Description

Setup

Enjoying Music

Enjoying Videos / Photos

Application

Android

Connections

Settings

Other Operations

Notifications

Announcements

Specifications

[Contents](#)

[Specifications](#)



[▶ Troubleshooting](#)

How to Use

What You Can Do

Parts Description

Setup

Enjoying Music

Enjoying Videos / Photos

Application

Android

Connections

Settings

Other Operations

Notifications

Announcements

Supported formats

[Supported formats](#)



[▶ Troubleshooting](#)

How to Use

What You Can Do

Parts Description

Setup

Enjoying Music

Enjoying Videos / Photos

Application

Android

Connections

Settings

Other Operations

Notifications

Announcements

Touch screen

[Caring for the touch screen](#)

You might be looking for the following topics:

[How to use the touch screen](#)

[Notes on the touch screen](#)



[▶ Troubleshooting](#)

How to Use

What You Can Do

Parts Description

Setup

Enjoying Music

Enjoying Videos / Photos

Application

Android

Connections

Settings

Other Operations

Notifications

Announcements

License/trademarks

[License and trademark notice](#)

[▶ Troubleshooting](#)**How to Use**

What You Can Do

Parts Description

Setup

Enjoying Music

Enjoying Videos / Photos

Application

Android

Connections

Settings

Other Operations

Notifications

Announcements**Manual**[About the "WALKMAN" manuals](#)[Notation in explanations of operations](#)

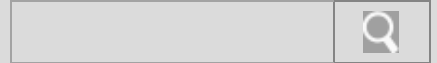

[▶ Troubleshooting](#)

How to Use

What You Can Do

Parts Description

Setup

Enjoying Music

Enjoying Videos / Photos

Application

Android

Connections

Settings

Other Operations

Notifications

Announcements

Sample data

[Sample data](#)



[▶ Troubleshooting](#)

How to Use

[What You Can Do](#)

[Parts Description](#)

[Setup](#)

[Enjoying Music](#)

[Enjoying Videos / Photos](#)

[Application](#)

[Android](#)

[Connections](#)

[Settings](#)

[Other Operations](#)

[Notifications](#)

[Announcements](#)

Support website

[Customer support websites](#)

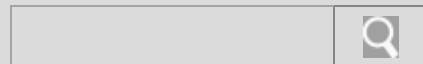

[▶ Troubleshooting](#)

How to Use

What You Can Do

Parts Description

Setup

Enjoying Music

Enjoying Videos / Photos

Application

Android

Connections

Settings

Other Operations

Notifications

Announcements

System requirements

[System requirements](#)



[▶ How to Use](#)

Troubleshooting

General

Music

Video / Photo

Apps

Supplied Software

General

[Bluetooth](#)

[Connection](#)

[Deletion](#)

[FM radio](#)

[Operation](#)

[Power](#)

[Transfer](#)

[Charging](#)

[DLNA](#)

[Display](#)

[General](#)

[Playback](#)

[Sound](#)

[USB connection](#)



[▶ How to Use](#)

Troubleshooting

General

Music

Video / Photo

Apps

Supplied Software

Music

[Deletion](#)

[Playback](#)

[Transfer](#)

[Display](#)

[Sound](#)

[USB connection](#)

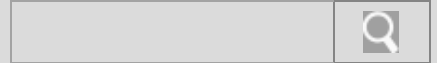

NWZ-Z1040/Z1050/Z1060

[Back](#) | [Back to Top](#)

[▶ How to Use](#)

Troubleshooting

General

Music

Video / Photo

Apps

Supplied Software

Video / Photo

[Display](#)

[Sound](#)

[USB connection](#)

[Playback](#)

[Transfer](#)

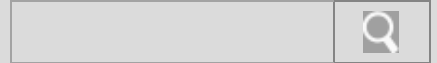

[▶ How to Use](#)

Troubleshooting

General

Music

Video / Photo

Apps

Supplied Software

Apps

[DLNA](#)

[General](#)

[FM radio](#)

[Help guide](#)

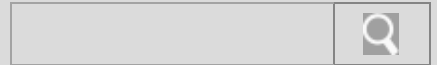

NWZ-Z1040/Z1050/Z1060

[Back](#) | [Back to Top](#)

[▶ How to Use](#)

Troubleshooting

General

Music

Video / Photo

Apps

Supplied Software

Supplied Software

[Installation](#)

[Transfer](#)

[USB connection](#)

[▶ Troubleshooting](#)

How to Use

What You Can Do

Parts Description

Setup

Enjoying Music

Enjoying Videos / Photos

Application

Android

Connections

Settings



Other Operations

Notifications

Announcements

Starting the Help guide on your "WALKMAN"

Start the Help guide installed on your "WALKMAN." The Help guide for viewing on your "WALKMAN" screen is provided only in some languages.

1. Tap [ Apps] from the Home screen then [ Browser].
2. Tap the  (Menu) button.
3. Tap [Bookmarks] - [Help guide].

Related topic

[About the "WALKMAN" manuals](#)

[Starting the Help guide on a computer](#)

[▶ Troubleshooting](#)**How to Use**

What You Can Do

Parts Description

Setup

Enjoying Music

Enjoying Videos / Photos

Application

Android

Connections

Settings

Other Operations

Notifications

Announcements

Starting the Help guide on a computer

The Help guide (for viewing on a computer screen) can be viewed by installing WALKMAN Guide on your computer.

1. Double click the  (WALKMAN Guide) icon on the desktop.
2. Click on the Help guide to open it.

Hint

- For details on how to install WALKMAN Guide, refer to the supplied "Quick Start Guide."

Related topic

[About the "WALKMAN" manuals](#)

[Starting the Help guide on your "WALKMAN"](#)

[▶ Troubleshooting](#)**How to Use**

What You Can Do

Parts Description

Setup

Enjoying Music

Enjoying Videos / Photos

Application

Android

Connections

Settings

Other Operations

Notifications

Announcements

About the Bluetooth function

The Bluetooth function enables wireless data transfer between devices that support Bluetooth communication technology.

You can transfer data between these devices at a range of up to 10 meters in an open area. Bluetooth devices need to be “paired” with each other the first time a wireless connection is made.

Once paired, the Bluetooth device and your “WALKMAN” can subsequently be connected with a simple operation. [\[Details\]](#)

Related topic

[Turning the Bluetooth function on and off](#)

[Enabling other Bluetooth devices to discover your “WALKMAN”](#)

[Pairing \(registering\) with a Bluetooth device](#)

[Connecting with a Bluetooth device](#)

[Disconnecting from a Bluetooth device](#)

[Unpairing from a Bluetooth device](#)

[Notes on the Bluetooth function](#)

[▶ Troubleshooting](#)

How to Use

What You Can Do

Parts Description

Setup

Enjoying Music

Enjoying Videos / Photos

Application

Android

Connections

Settings

Other Operations

Notifications

Announcements

Connecting with a Bluetooth device

Connect a paired Bluetooth device with your "WALKMAN."

1. Tap the (Menu) button with the Home screen displayed, then tap [Settings] - [Wireless & networks] - [Bluetooth settings].
2. Press and hold the name of the device you want to connect with in the list.
3. Tap [Connect].
 will be displayed in the status bar while connected.

Depending on the type of device, [Paired but not connected] / [Connected to media audio] will be displayed under the device name.

Related topic

[About the Bluetooth function](#)

[Turning the Bluetooth function on and off](#)

[Enabling other Bluetooth devices to discover your "WALKMAN"](#)

[Pairing \(registering\) with a Bluetooth device](#)

[Disconnecting from a Bluetooth device](#)

[Unpairing from a Bluetooth device](#)

[Notes on the Bluetooth function](#)



▶ Troubleshooting

How to Use

What You Can Do

Parts Description

Setup

Enjoying Music

Enjoying Videos / Photos

Application

Android

Connections

Settings



Other Operations

Notifications

Announcements

Disconnecting from a Bluetooth device

Disconnect from the Bluetooth device you are connected to. Pairing will not end, even if you disconnect.

1. Press the  (Menu) button with the Home screen displayed, then tap [ Settings] - [ Wireless & networks] - [Bluetooth settings].
2. Press and hold the name of the device you want to disconnect from in the list.
3. Tap [Disconnect].

Hint

- To reduce battery consumption, turn off the Bluetooth function when not in use.

Related topic

[About the Bluetooth function](#)

[Turning the Bluetooth function on and off](#)

[Enabling other Bluetooth devices to discover your "WALKMAN"](#)

[Connecting with a Bluetooth device](#)

[Unpairing from a Bluetooth device](#)

[Notes on the Bluetooth function](#)



▶ Troubleshooting

How to Use

What You Can Do

Parts Description

Setup

Enjoying Music

Enjoying Videos / Photos

Application

Android

Connections

Settings

Other Operations

Notifications





Announcements

Enabling other Bluetooth devices to discover your "WALKMAN"

You can allow other Bluetooth devices to discover your "WALKMAN."

Depending on the device, the procedure to establish a connection may vary. Refer to the operating instructions of the Bluetooth device.

For details on Bluetooth communications, see "About the Bluetooth function." [\[Details\]](#)

1. Tap the  (Menu) button with the Home screen displayed, then tap  [Settings] - [ Wireless & networks] - [Bluetooth].
A checkmark will be added, and Bluetooth function will turn on. The  will be displayed in the status bar.
2. Tap [Bluetooth settings] - [Discoverable] .
A checkmark will be added, and your "WALKMAN" will be discoverable by other Bluetooth devices for 120 seconds.

Related topic

[About the Bluetooth function](#)

[Turning the Bluetooth function on and off](#)

[Pairing \(registering\) with a Bluetooth device](#)

[Connecting with a Bluetooth device](#)

[Notes on the Bluetooth function](#)



▶ Troubleshooting

How to Use

What You Can Do

Parts Description

Setup

Enjoying Music

Enjoying Videos / Photos

Application

Android

Connections

Settings

Other Operations

Notifications

Announcements

Notes on the Bluetooth function

The following are notes regarding use of the Bluetooth function.

- Bluetooth wireless technology allows connection at as distance of up to about 10 meters. However, the effective range may vary depending on obstacles (people, metals, wall, etc.) or signal status.
- The following conditions may cause noise, sound break or playback speed change with a Bluetooth connection.
 - Using inside a metal case
 - Using inside a backpack or other bag held on the back or shoulder
 - Using in locations where a wireless network is in place, microwave oven is in use, or other electromagnetic waves are produced
- Because Bluetooth and wireless LAN (IEEE802.11b/g) devices use the same frequency (2.4 GHz), signal interference may occur that results in communication speed deterioration, noise, or inability to connect if Bluetooth communications is used near a wireless LAN device. In such a case, perform the following.
 - Perform Bluetooth communications at least 10 meters away from the wireless LAN device when connecting your "WALKMAN" and a Bluetooth device.
 - Place your "WALKMAN" and the Bluetooth device as close together as possible.
 - Turn off the wireless LAN device when performing Bluetooth communications within about 10 meters of a wireless LAN device.
- Due to a characteristic of Bluetooth wireless technology, the sound played on the receiving Bluetooth device is slightly delayed from the sound of the sending device.
- Radio waves emitting from a Bluetooth device may affect the operation of equipment such as electronic medical devices. Turn off your "WALKMAN" and other Bluetooth device in the following locations, as failure to do so may cause an accident.
 - In hospitals, near priority seats on trains, in airplanes, in places such as gasoline stations where flammable gases are present, near automatic doors or fire alarms
- Your "WALKMAN" supports security functions that comply with the Bluetooth standard to provide a secure connection when Bluetooth technology is used, but security may not be sufficient depending on the settings. Be careful when connecting using Bluetooth technology.
- Sony bears no responsibility whatsoever for information leaks as a result of using Bluetooth technology.
- Your "WALKMAN" is not guaranteed to connect with all Bluetooth devices.
 - Bluetooth devices you connect to must conform to the Bluetooth standard specified by Bluetooth SIG and be certified.
 - Even if the connected device conforms to the above-mentioned Bluetooth standard, some devices may not be connected or work correctly depending on the features or specifications of the device.
- Depending on the device to be connected, the Bluetooth connection may take some time to establish.

Notes on the built-in antenna

- Your "WALKMAN" is equipped with an antenna. The sensitivity of the Bluetooth connection will improve by facing the antenna part towards the connected Bluetooth device. The effective range of the connection will differ if obstacles are between your "WALKMAN" and the Bluetooth device.
- Do not cover the antenna with your hand or other object when connected with the Bluetooth connection. Doing so may obstruct the Bluetooth connection.

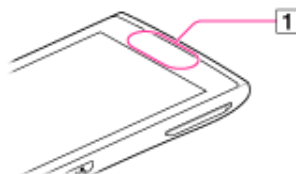

1 Built-in antenna

© 2012 Sony Corporation



▶ Troubleshooting

How to Use

What You Can Do

Parts Description

Setup

Enjoying Music

Enjoying Videos / Photos

Application

Android

Connections

Settings

Other Operations



Notifications

Announcements

Pairing (registering) with a Bluetooth device

To connect with a new Bluetooth device, you need to pair with it while the Bluetooth function of your "WALKMAN" is turned on.

You only need to do this once for your "WALKMAN" and the new Bluetooth device. Just turn on the device the next time. [\[Details\]](#)

1. Put the Bluetooth device you want to connect with in discoverable mode.
Refer to the operating instructions supplied with the Bluetooth device for details on procedures for putting it in discoverable mode.
2. Tap the  (Menu) button with the Home screen displayed, then tap [ Settings] - [ Wireless & networks] - [Bluetooth settings] - [Scan for devices].
3. Tap the device to set pairing for from the list, and make sure the same number is displayed on the screen of your "WALKMAN" and that device.
The pairing and connection status will be displayed under the Bluetooth device name.
With some devices, a connection is established after pairing.

Note

- A passkey (*1) input screen is displayed with some devices. Check the passkey of the other device, and input the passkey.
(*1) "Passkey" is also called "Pass code," "PIN code," "PIN number," or "Password."
For the passkey of the other device, see the manual for that device.

Related topic

[About the Bluetooth function](#)

[Turning the Bluetooth function on and off](#)

[Enabling other Bluetooth devices to discover your "WALKMAN"](#)

[Connecting with a Bluetooth device](#)

[Unpairing from a Bluetooth device](#)

[Notes on the Bluetooth function](#)

[▶ Troubleshooting](#)

How to Use

What You Can Do

Parts Description

Setup

Enjoying Music

Enjoying Videos / Photos

Application

Android

Connections

Settings

Other Operations

Notifications



Announcements

Turning the Bluetooth function on and off

To connect Bluetooth devices with your "WALKMAN," you first have to turn on the Bluetooth function.

Depending on the device, the procedure to establish connection may vary. Refer to the operating instructions of the Bluetooth device.

For details on Bluetooth communications, see "About the Bluetooth function." [\[Details\]](#)

1. Tap the  (Menu) button with the Home screen displayed, then tap [ Settings] - [ Wireless & networks] - [Bluetooth].

A checkmark will be added, and the Bluetooth function will turn on. The  will be displayed in the status bar.

Tapping [Bluetooth] again will remove the checkmark, and the Bluetooth function will turn off.

Note

- To reduce battery consumption, turn off the Bluetooth function when not in use.
- The Bluetooth communications antenna is built in to your "WALKMAN." If you cover the antenna with your hands or other objects while using Bluetooth communications, the communications quality may be affected. [\[Details\]](#)

Related topic

[About the Bluetooth function](#)

[Enabling other Bluetooth devices to discover your "WALKMAN"](#)

[Pairing \(registering\) with a Bluetooth device](#)

[Connecting with a Bluetooth device](#)

[Disconnecting from a Bluetooth device](#)

[Unpairing from a Bluetooth device](#)

[Notes on the Bluetooth function](#)

[▶ Troubleshooting](#)

How to Use

What You Can Do

Parts Description

Setup

Enjoying Music

Enjoying Videos / Photos

Application

Android

Connections

Settings



Other Operations

Notifications

Announcements

Unpairing from a Bluetooth device

Unpair from a Bluetooth device while the Bluetooth function is turned on.

1. Tap the  (Menu) button with the Home screen displayed, then tap [ Settings] - [ Wireless & networks] - [Bluetooth settings] - [Scan for devices].
2. Press and hold the name of the device you want to unpair from in the list.
3. Tap [Unpair].
Pairing ends.

Hint

- If connected to the Bluetooth device to unpair from, [Disconnect & unpair] will be displayed.

Related topic

[About the Bluetooth function](#)

[Enabling other Bluetooth devices to discover your "WALKMAN"](#)

[Pairing \(registering\) with a Bluetooth device](#)

[Disconnecting from a Bluetooth device](#)

[Notes on the Bluetooth function](#)

[▶ Troubleshooting](#)**How to Use**

What You Can Do

Parts Description

Setup

Enjoying Music

Enjoying Videos / Photos

Application

Android

Connections

Settings



Other Operations

Notifications

Announcements

About FM radio

You can listen to FM radio on your "WALKMAN."

1. Connect the supplied headphones to the headphone jack on your "WALKMAN."
2. From the Home screen, tap [ Apps] - [ FM radio].





Related topic

[How to use the FM radio screen](#)

[Listening to FM radio](#)

[▶ Troubleshooting](#)**How to Use****What You Can Do****Parts Description****Setup****Enjoying Music****Enjoying Videos / Photos****Application****Android****Connections****Settings****Other Operations****Notifications****Announcements****Deleting preset stations**

Delete preset stations.

1. From the Home screen, tap [ Apps] - [ FM radio].
2. Select a preset number using [ + /  -].
3. Tap the  (Menu) button, and then tap [Delete from preset].

Related topic[Listening to FM radio](#)[Presetting stations automatically \(auto preset\)](#)[Presetting stations manually](#)



▶ Troubleshooting

How to Use

What You Can Do

Parts Description

Setup

Enjoying Music

Enjoying Videos / Photos

Application

Android

Connections

Settings

Other Operations

Notifications

Announcements

How to use the FM radio screen

You can select the desired frequency or preset number on the FM radio screen for receivable stations.

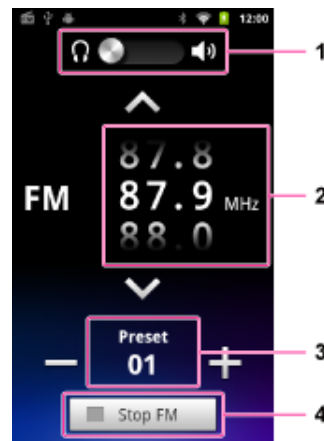

1. Headphone/speaker switching
2. Frequency
3. Preset number
4. FM playback/pause

Operations on the FM radio screen

Select the previous/next frequency:

Drag or flick the frequency up or down.

Select the previous/next receivable station (*1):

Tap / .

Select the previous/next preset number (*2):

Tap / .

Play/pause FM radio:

Tap [Play FM]/[Stop FM].

(*1) If sensitivity is too high, change the scan sensitivity setting [\[Details\]](#) to [Low].

(*2) You cannot select a preset number if no station is set. Automatically set receivable stations using [Auto preset] [\[Details\]](#), or set the stations manually. [\[Details\]](#)

Related topic

[Listening to FM radio](#)



▶ Troubleshooting

How to Use

What You Can Do

Parts Description

Setup

Enjoying Music

Enjoying Videos / Photos

Application

Android

Connections

Settings

Other Operations

Notifications

Announcements

Listening to FM radio

You can listen to FM radio on your "WALKMAN."

1. Connect the supplied headphones to the headphone jack on your "WALKMAN."
2. From the Home screen, tap [Apps] - [FM radio].
3. Drag or flick up and down to select a frequency, or use [/] to select a preset number.

Note

- You cannot select a preset number if no station is set. Automatically set receivable stations using the auto preset function [\[Details\]](#), or set the stations manually. [\[Details\]](#)
- The headphone cord serves as an antenna, so extend it as far as possible.
- You can continue to receive FM radio even if you go back to the Home screen or display another screen while listening to FM radio. To stop FM radio, tap [Stop FM] on the FM radio screen.
- You cannot listen to FM radio while connected by the Bluetooth function, WM-PORT, or HDMI.
- You cannot listen to FM radio when the headphones are not connected.

Related topic

[Presetting stations automatically \(auto preset\)](#)
[Setting FM radio to monaural/stereo](#)



▶ Troubleshooting

How to Use

What You Can Do

Parts Description

Setup

Enjoying Music

Enjoying Videos / Photos

Application

Android

Connections

Settings

Other Operations

Notifications

Announcements

Presetting stations automatically (auto preset)

You can preset receivable stations in your area (up to 30) automatically with the auto preset function.

1. From the Home screen, tap [Apps] - [FM radio], and then tap the (Menu) button.
2. Tap [Auto preset] - [OK].
Receivable stations will be preset in order by frequency (low to high).

Hint

- If high sensitivity causes your “WALKMAN” to receive many unwanted stations due to their signal status when auto presetting, change the scan sensitivity setting [[Details](#)] to [Low].

Note

- Auto presetting will erase stations already set.

Related topic

[Presetting stations manually](#)

[Listening to FM radio](#)

[Deleting preset stations](#)

[▶ Troubleshooting](#)**How to Use**

What You Can Do

Parts Description

Setup

Enjoying Music

Enjoying Videos / Photos

Application

Android

Connections

Settings

Other Operations

Notifications

Announcements

Presetting stations manually

You can manually preset receivable stations (up to 30).

1. From the Home screen, tap [Apps] - [FM radio].
2. Drag or flick up or down to select the frequency to set.
3. Tap the (Menu) button, and then tap [Save to preset].

Note

- Preset numbers are reassigned in order by frequency (low to high).

Related topic[Presetting stations automatically \(auto preset\)](#)[Listening to FM radio](#)[Deleting preset stations](#)

[▶ Troubleshooting](#)**How to Use****What You Can Do****Parts Description****Setup****Enjoying Music****Enjoying Videos / Photos****Application****Android****Connections****Settings****Other Operations****Notifications****Announcements****Setting FM radio to monaural/stereo**



If there is much noise during FM radio reception, set to [Mono] for monaural. If you set to [Auto], monaural/stereo reception is selected automatically depending on reception conditions. The setting at time of purchase is [Auto].

1. From the Home screen, tap [Apps] - [FM radio].
2. Tap the (Menu) button, and then tap [Mono/Auto].
3. Tap the setting you want.

Related topic[Listening to FM radio](#)

[▶ Troubleshooting](#)**How to Use****What You Can Do****Parts Description****Setup****Enjoying Music****Enjoying Videos / Photos****Application****Android****Connections****Settings****Other Operations****Notifications****Announcements****Setting the FM radio scan sensitivity**

If high sensitivity causes your "WALKMAN" to receive unwanted stations when searching for stations, set the scan sensitivity setting to [Low]. Sensitivity is set to [High] at time of purchase.

1. From the Home screen, tap [ Apps] - [ FM radio].
2. Tap the  (Menu) button, and then tap [Scan sensitivity].
3. Tap the setting you want.

Related topic[Presetting stations automatically \(auto preset\)](#)[Presetting stations manually](#)[Deleting preset stations](#)

[▶ Troubleshooting](#)**How to Use**

What You Can Do

Parts Description

Setup

Enjoying Music

Enjoying Videos / Photos

Application

Android

Connections

Settings

Other Operations

Notifications

Announcements

About HDMI

You can connect your "WALKMAN" to a TV or other device with an HDMI cable to enjoy videos and music on that device.

Related topic

[Connecting by HDMI](#)

[▶ Troubleshooting](#)**How to Use**[What You Can Do](#)[Parts Description](#)[Setup](#)[Enjoying Music](#)[Enjoying Videos / Photos](#)[Application](#)[Android](#)[Connections](#)[Settings](#)[Other Operations](#)[Notifications](#)[Announcements](#)**Connecting by HDMI**

Connect your "WALKMAN" to a TV with an HDMI cable (Type D) to output videos and music.

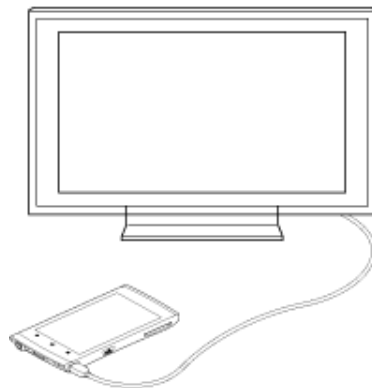
**Note**

- Disconnect the HDMI cable when not using the HDMI connection. The battery may be depleted faster if left connected.

Related topic[About HDMI](#)



▶ Troubleshooting

How to Use

What You Can Do

Parts Description

Setup

Enjoying Music

Enjoying Videos / Photos

Application

Android

Connections

Settings

Other Operations

Notifications

Announcements

Home screen

Application widgets, shortcuts, folders, and more are displayed on the Home screen.



1. Music player widget
Controls music playback.
2. Apps
Starts the applications screen.
3. Video player shortcut
Starts Video player. [\[Details\]](#)
4. Music player shortcut
Starts Music player. [\[Details\]](#)
5. Original apps
Displays applications recommended by Sony.
6. Favorites
Starts Favorites. [\[Details\]](#)



▶ Troubleshooting

How to Use

What You Can Do

Parts Description

Setup

Enjoying Music

Enjoying Videos / Photos

Application

Android

Connections

Settings

Other Operations

Notifications

Announcements

About notification panel

Swipe the status bar to display the notification panel on which you can check the notification details.

You can also start the relevant application directly by tapping a notification on the panel.

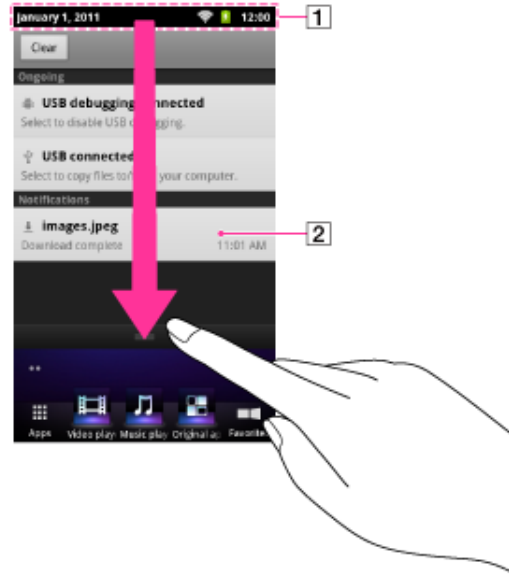

1 Notification panel

2 Notification

Hint

- Tap the  (Back) button to close the notification panel.



▶ Troubleshooting

How to Use

What You Can Do

Parts Description

Setup

Enjoying Music

Enjoying Videos / Photos

Application

Android

Connections

Settings

Other Operations

Notifications

Announcements

Editing Favorites

You can edit items displayed in Favorites as you like.

1. Tap [Favorites] on the Home Screen.
2. Tap the (Menu) button, and tap [Edit].
3. Edit as follows.
 - To add items:
Select the item to add from the list, and tap it.
 - To delete an item:
Tap on the thumbnail. Or select the item to delete from the list, and tap it.
 - To move an item:
Drag and drop the thumbnail.
4. When you have finished editing, tap .

Related topic

[Using Favorites](#)



▶ Troubleshooting

How to Use

What You Can Do

Parts Description

Setup

Enjoying Music

Enjoying Videos / Photos

Application

Android

Connections

Settings

Other Operations

Notifications

Announcements

Main notification icons

The main notification icons that are displayed on the screen are as follows.

	New mail
	New mail (Google application)
	Receiving/downloading data
	Sending/uploading data
	Transferring data using Bluetooth function
	Installation complete (when application installed via Android Market, etc.)
	System update notification
	Application update (when update for installed market application available)
	Event scheduled on calendar
	Song playing back
	FM radio in use
	USB connection active
	Error message
	Login/sync error
	Notification not displayed by other icons
	Content being sent to another device for playback

Items displayed differ in some countries/regions.

[▶ Troubleshooting](#)**How to Use****What You Can Do****Parts Description****Setup****Enjoying Music****Enjoying Videos / Photos****Application****Android****Connections****Settings****Other Operations****Notifications****Announcements****Using Favorites**

Content such as music, videos, and photos that you have recently listened to or viewed can be freely set in Favorites.

Set content items are visible in a list, so you can start the desired content with one tap without starting/ending apps repeatedly.

1. Tap [ Favorites] on the Home Screen.
2. Tap the item you want to listen to or view.
Detailed information of the content for the item is displayed.
3. Tap the content to listen to or view.
The corresponding application starts.

Hint

- Tapping the item selected in step 2 again allows you to start playback of the content.

Related topic[Editing Favorites](#)

[▶ Troubleshooting](#)**How to Use****What You Can Do****Parts Description****Setup****Enjoying Music****Enjoying Videos / Photos****Application****Android****Connections****Settings****Other Operations****Notifications****Announcements****About Music player**

In addition to playing music imported to your "WALKMAN," the Music player application on your "WALKMAN" can automatically select and play songs according to your situation [\[Details\]](#) as well as easily share music with other devices on the home network. [\[Details\]](#)

1. From the Home screen, tap [ Apps] - [ Music player].

Related topic[How to use the music playback screen](#)[Playing music](#)[Deleting songs](#)



▶ Troubleshooting

How to Use

What You Can Do

Parts Description

Setup

Enjoying Music

Enjoying Videos / Photos

Application

Android

Connections

Settings

Other Operations

Notifications

Announcements

Changing music settings

A variety of settings are available for music functions.

1. From the Home screen, tap [Apps] - [Music player].
2. Tap the (Menu) button, then tap [Settings].
3. Tap the item to set.
The following items can be set or confirmed.

Equalizer:

Chooses sound quality according to the song or genre.

VPT (Surround) (*1):

Gives a "live" feel to sound played back by setting acoustic effects using the VPT (Surround) function.

DSEE (Sound enhance) (*2):

Processes compressed sound sources to give high sound quality, and compensates the high range removed in compression to re-create natural sound with a wide feel close to the original sound source.

Clear stereo:

Digitally processes the sound from left and right sides of the supplied headphones to clearly differentiate them and re-create sound with stereo feel emphasized.

Dynamic normalizer:

Moderates the volume level between songs to minimize differences in their recording levels. This setting prevents the volume from being too high or too low in shuffle playback of songs from multiple albums with differing recording levels.

xLOUD™:

Plays powerful sound from the built-in speakers.

Clear Phase™:

Sets sound quality appropriate to the built-in speakers.

Keep screen on:

Sets so the screen does not turn off automatically when displaying lyrics.

Update database:

Searches music files and registers them to a database.

About Music player:

Displays the application version.

(*1) VPT: Virtualphones Technology is special acoustic effects developed independently by Sony.

(*2) DSEE stands for Digital Sound Enhancement Engine, a high range compensation technology developed independently by Sony.

Related topic

[Playing music](#)

[▶ Troubleshooting](#)**How to Use****What You Can Do****Parts Description****Setup****Enjoying Music****Enjoying Videos / Photos****Application****Android****Connections****Settings****Other Operations****Notifications****Announcements****Deleting songs**

Songs transferred to your "WALKMAN" from a computer cannot be deleted using your "WALKMAN." Connect to a computer to delete songs.

Deleting songs transferred using Media Go

1. Connect your "WALKMAN" to a computer with the supplied USB cable. [\[Details\]](#)
2. Use Media Go on your computer to delete songs.

Deleting songs transferred using the Windows Explorer

1. Connect your "WALKMAN" to a computer with the supplied USB cable. [\[Details\]](#)
2. Use the Windows Explorer on your computer to delete songs.

Hint

- Sample music is preinstalled on your "WALKMAN." Use Media Go to delete the sample music.

Related topic[Transferring content using Media Go](#)[Dragging and dropping data to a computer with USB connection](#)



▶ Troubleshooting

How to Use

What You Can Do

Parts Description

Setup

Enjoying Music

Enjoying Videos / Photos

Application

Android

Connections

Settings

Other Operations

Notifications

Announcements

How to use the music playback screen

You can control playback of songs and display/search for information on the music playback screen.

Music playback screen



1. / /

Tap this to return to the previous screen.

2. Song information area

Flick left or right to switch between song list, cover art, lyrics, and information screens.

[\[Details\]](#)

3. Song name

4. Artist name

5. Album name

6. Playback status display

7. Playback information area

Icons are displayed for [Throw] [\[Details\]](#), [Visualizer] [\[Details\]](#), [Repeat off], and [Shuffle off].

8. Elapsed time

9. Current song number/Total songs to be played

10. Total time (*1)

11. Timeline bar (*1)

(*1) While playing back variable bit rate (VBR) songs, the elapsed time indication and the timeline bar may be unstable and inaccurate.

Operations on the music playback screen



Tap to play/pause.



Press and hold to fast forward/fast rewind.



Tap to go to beginning of previous (or current) /next song.

Timeline bar:

Tap on the timeline bar, or drag the indicator (playback point) to move the playback point quickly.

Hint

- Displays other than the song information area, song name, artist name, and album name will turn off if no operations are made for a certain amount of time. To display them again, tap the screen.

Related topic

[Switching the information area display](#)

[▶ Troubleshooting](#)**How to Use****What You Can Do****Parts Description****Setup****Enjoying Music****Enjoying Videos / Photos****Application****Android****Connections****Settings****Other Operations****Notifications****Announcements****Playing music**

Play music imported to your "WALKMAN."

1. From the Home screen, tap [ Apps] - [ Music player].
2. Select a song. [\[Details\]](#)

Related topic[Selecting songs from the library](#)[Selecting an album by cover art](#)[Playing songs in playlists](#)[Using the Visualizer](#)[Using the mini player](#)



▶ Troubleshooting

How to Use

What You Can Do

Parts Description

Setup

Enjoying Music

Enjoying Videos / Photos

Application

Android

Connections

Settings

Other Operations

Notifications

Announcements

Playing songs in playlists

Playlists are lists of songs to play back created by using Media Go. Those playlists can be transferred to your "WALKMAN" and played back. For information on how to create a playlist, refer to the help guide of Media Go. Cover art images registered to a playlist are not displayed on your "WALKMAN."

1. From the Home screen, tap [Apps] - [Music player].
2. Tap [Library] - [Playlists].

Hint

- If the music playback screen is displayed, tap the screen then , , or displayed at the top left of the screen. Then tap [Library].
3. Tap the playlist to play from the displayed list.
 4. Tap the song to play from the displayed list.

Related topic

[Playing music](#)



▶ Troubleshooting

How to Use

What You Can Do

Parts Description

Setup

Enjoying Music

Enjoying Videos / Photos

Application

Android

Connections

Settings

Other Operations

Notifications

Announcements

Selecting an album by cover art

Tap the cover art to select an album.

1. From the Home screen, tap [Apps] - [Music player] - [Cover art view].

Hint

- If the music playback screen is displayed, tap the screen then , , or displayed at the top left of the screen. Then tap [Cover art view].

2. Tap [Albums] or [Artists].

Cover art is displayed.

Hint

- You can drag cover art to change the layout.

3. Tap the cover art of the album you want to play.
Playback starts.

Hint

- You can register cover art from the list displayed by tapping the (Menu) button with the music playback screen displayed and tapping [Add cover art].
- Cover art can be registered in Media Go. For information on how to register cover art, refer to the help guide of Media Go.

Note

- Cover art is displayed only if cover art information is added to the song.
- Cover art in some formats may not display on your "WALKMAN."

Related topic

[Selecting songs from the library](#)



▶ Troubleshooting

How to Use

What You Can Do

Parts Description

Setup

Enjoying Music

Enjoying Videos / Photos

Application

Android

Connections

Settings

Other Operations

Notifications

Announcements

Selecting songs from the library

You can quickly select songs by information such as artist name and genre.

1. From the Home screen, tap [Apps] - [Music player].
2. Tap [Library], and then tap the icon of the search method of your choice.

Hint

- If the music playback screen is displayed, tap the screen then , , or displayed at the top left of the screen. Then tap [Library].

You can search by the following items.

- All songs
- Albums
- Artists
- Genres
- Release year
- Recently added
- Playlists
- Folders

Hint

- “The” at the beginning of artist names is ignored when arranging the [Artists] list.
- Playlists are created using Media Go. For information on how to create a playlist, refer to the help guide of Media Go. Cover art images registered to a playlist are not displayed on your “WALKMAN.”

Related topic

[Selecting an album by cover art](#)



▶ Troubleshooting

How to Use

What You Can Do

Parts Description

Setup

Enjoying Music

Enjoying Videos / Photos

Application

Android

Connections

Settings

Other Operations

Notifications

Announcements

Switching the information area display

Flick left or right to display the following screens.

Song list screen

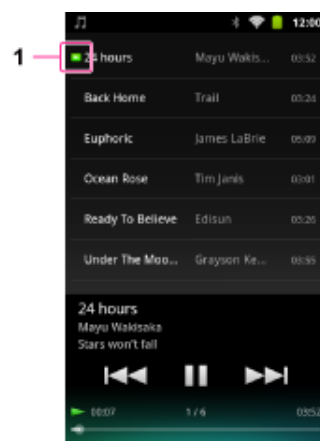

1. The song currently playing is displayed.

Lyrics screen

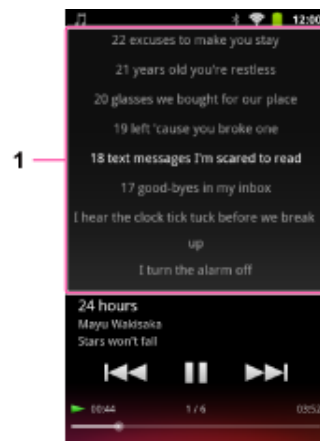

1. Lyrics
Lyrics added to the song on your "WALKMAN" are displayed.
If you tap on the lyrics, playback starts from the part of the song touched.
- Note**
- If the lyrics were added by typing directly or by importing from text files, you cannot change the playback point by tapping lyrics.

Information screen

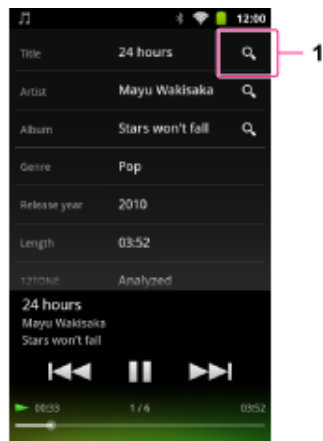

1. 

Tap this to search for related information on websites, etc.

Related topic

[How to use the music playback screen](#)



▶ Troubleshooting

How to Use

What You Can Do

Parts Description

Setup

Enjoying Music

Enjoying Videos / Photos

Application

Android

Connections

Settings

Other Operations

Notifications

Announcements

Using the Visualizer

Cover art is displayed as graphics matching the song being played back based on 12 TONE ANALYSIS of the song. You can select the theme of your choice for the graphics display.

1. From the Home screen, tap [Apps] - [Music player].
2. Select a song. [\[Details\]](#)
3. Tap .

Hint

- To change the theme, tap the (Menu) button then tap [Select a theme].
- To perform 12 TONE ANALYSIS on the song being played, tap the (Menu) button then tap [Music analyzer] - [Analyze].

Related topic

[Using the mini player](#)



▶ Troubleshooting

How to Use

What You Can Do

Parts Description

Setup

Enjoying Music

Enjoying Videos / Photos

Application

Android

Connections

Settings

Other Operations

Notifications

Announcements

Using the mini player

You can display a mini player on the library, "SensMe™ channels," and cover art screens to control playback.

1. From the Home screen, tap [Apps] - [Music player].
2. Tap [Library], [SensMe™ channels], or [Cover art view].

Hint

- If the music playback screen is displayed, tap the screen then , , or displayed at the top left.

3. Flick the bottom of the screen upwards.

The mini player is displayed at the bottom of the screen.

Hint

- The mini player can also be displayed by tapping the bottom of the screen.

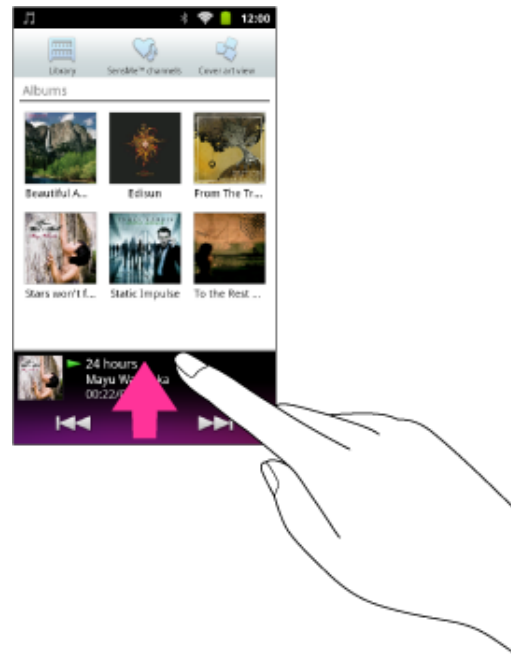

To close, flick the mini player downwards.

Hint

- Tap the cover art displayed on the mini player to display the music playback screen.

Related topic

[Using the Visualizer](#)



▶ Troubleshooting

How to Use

What You Can Do

Parts Description

Setup

Enjoying Music

Enjoying Videos / Photos

Application

Android

Connections

Settings

Other Operations

Notifications

Announcements

Preinstalled applications

The following apps are preinstalled on your "WALKMAN" at time of purchase. You can start individual applications by tapping on their icons. An overview of and instructions on using some applications can be found in the Help guide. The types of the preinstalled applications vary depending on countries/regions.

A Wi-Fi connection is required to use applications marked with (*1).

Applications provided by Google, such as Browser, Google Search, and Calendar, are preinstalled. For details on the preinstalled applications, search the Internet. The application names may be changed without notice.

FM radio

Listen to FM radio on your "WALKMAN." [\[Details\]](#)

Original apps

Display a list of Sony applications.

Photo viewer

View photos and slide shows, and play back content on DLNA devices. [\[Details\]](#)

W.control

Configure various settings for the W.control displayed by pressing the  (Double-u Dot) button. [\[Details\]](#)

Favorites

Freely set content you often use such as music, videos, and photos. [\[Details\]](#)

Video player

Play back video files by intuitive operations. [\[Details\]](#)

Music player

Play back music files transferred by Media Go or drag and drop. [\[Details\]](#)

DLNA (*1)

Connect your "WALKMAN" to the home network to play back content from another DLNA compliant device (server) on your "WALKMAN." [\[Details\]](#)

Wi-Fi checker (*1)

Check the Wi-Fi connection status of your "WALKMAN" when problems occur with the Wi-Fi connection. [\[Details\]](#)

[▶ Troubleshooting](#)**How to Use**

What You Can Do

Parts Description

Setup

Enjoying Music

Enjoying Videos / Photos

Application

Android

Connections

Settings

Other Operations

Notifications

Announcements

About USB connection

USB connection is a method of connecting your "WALKMAN" and a USB device using the WM-PORT jack.

Related topic[Connecting by USB](#)[Notes on USB connection](#)



▶ Troubleshooting

How to Use

[What You Can Do](#)

[Parts Description](#)

[Setup](#)

[Enjoying Music](#)

[Enjoying Videos / Photos](#)

[Application](#)

[Android](#)

[Connections](#)

[Settings](#)



[Other Operations](#)

[Notifications](#)

[Announcements](#)

Connecting by USB

You can connect your "WALKMAN" with a computer to exchange data between them.

1. Hold down the  (Power) button on your "WALKMAN" to turn on the power.
If remaining battery power is low and the power does not turn on, proceed to step 2. If the battery is depleted, it may take about 10 minutes before your "WALKMAN" can be used.
2. Use the supplied USB cable to connect your "WALKMAN" to a running computer.
Plug in the USB cable with  facing upward.

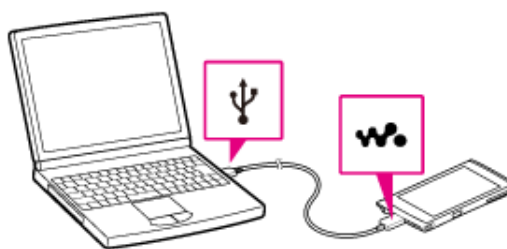

Hint

- If [USB connected] is displayed on the screen, tap [Turn on USB storage] to connect.
If the following screen is not displayed, swipe the status bar on the top of the screen then tap [USB connected] on the notification panel.



Your "WALKMAN" will then be accessible by clicking [Computer] (or [My Computer]) from the Windows [Start] menu.

Related topic

[About USB connection](#)

[Dragging and dropping data to a computer with USB connection](#)

[Disconnecting USB cable](#)

[Notes on USB connection](#)

[▶ Troubleshooting](#)

How to Use

[What You Can Do](#)
[Parts Description](#)
[Setup](#)
[Enjoying Music](#)
[Enjoying Videos / Photos](#)
[Application](#)
[Android](#)
[Connections](#)
[Settings](#)
[Other Operations](#)
[Notifications](#)
[Announcements](#)

Disconnecting USB cable

Follow the procedures below when disconnecting the USB cable to prevent damage to data.

1. Tap [Turn off USB storage] displayed on the screen of your "WALKMAN."
If that message is not displayed on the screen, swipe the status bar, then tap [Turn off USB storage] on the notification panel.



Hint

- Press the  (Power) button if the screen of your "WALKMAN" is off.
2. Disconnect the USB cable.

Note

- Do not disconnect the USB cable while transferring data.

Related topic

[Notes on USB connection](#)

[▶ Troubleshooting](#)**How to Use****What You Can Do****Parts Description****Setup****Enjoying Music****Enjoying Videos / Photos****Application****Android****Connections****Settings****Other Operations****Notifications****Announcements****Dragging and dropping data to a computer with USB connection**

You can exchange data between your "WALKMAN" and a computer connected using USB by dragging and dropping.

1. Use the supplied USB cable to connect your "WALKMAN" and a computer.
Your "WALKMAN" will be recognized by the computer, and you will be able to drag and drop data.
Drag and drop music data to the [Music] folder, video data to the [Video] folder, and photo data to the [Picture] or [DCIM] folder.

Note

- Content may not be played back if you change the name of folders such as [Music], [Video], [Picture] and [DCIM].

Hint

- Music, video and picture files in the data hierarchy levels 1 to 8 can be played.

Related topic[Connecting by USB](#)[Disconnecting USB cable](#)[Notes on USB connection](#)

[▶ Troubleshooting](#)**How to Use****What You Can Do****Parts Description****Setup****Enjoying Music****Enjoying Videos / Photos****Application****Android****Connections****Settings****Other Operations****Notifications****Announcements****Notes on USB connection**

The following are notes regarding use of USB connections.

- Do not turn off the power of your "WALKMAN" when reading or writing data.
- Do not remove the USB cable when transferring data between your "WALKMAN" and the computer. Doing so may result in loss of the data being transferred and data on your "WALKMAN."
- Do not turn on, restart, wake up from sleep mode, or shut down the computer with your "WALKMAN" connected to the computer by USB cable. Doing so may cause your "WALKMAN" to malfunction. Disconnect your "WALKMAN" from the computer before conducting those operations.



▶ Troubleshooting

How to Use

What You Can Do

Parts Description

Setup

Enjoying Music

Enjoying Videos / Photos

Application

Android

Connections

Settings

Other Operations

Notifications

Announcements

About Wi-Fi checker

The Wi-Fi checker app enables you to check the Wi-Fi connection of your “WALKMAN” when a connection problem occurs.

1. From the Home screen, tap [Apps] - [Wi-Fi checker] - [Test].

The connection test starts. Items are checked in succession, and assumed causes and remedies are displayed.

Hint

- If you tap the (Menu) button and then [Settings], you can display the settings screen for the Wi-Fi connection. Tap the (Back) button to return from the settings screen. If you tap the (Home) button at the settings screen to display the Home screen, the settings screen appears when you start the Wi-Fi checker the next time.

Related topic

[Connecting to a Wi-Fi network](#)

[Notes on Wi-Fi](#)

[▶ Troubleshooting](#)**How to Use**

What You Can Do

Parts Description

Setup

Enjoying Music

Enjoying Videos / Photos

Application

Android

Connections

Settings

Other Operations

Notifications

Announcements

About Wi-Fi communications

Wi-Fi* is a communications technology that allows for connection with wireless network devices bearing the Wi-Fi logo and use of public wireless networks.

You can use Wi-Fi to browse the Internet on your "WALKMAN" or connect to other communications devices.

* "Wi-Fi" indicates certification of compatibility with wireless network devices.

Related topic

[Turning Wi-Fi on and off](#)

[Connecting to a Wi-Fi network](#)

[Notes on Wi-Fi](#)

[▶ Troubleshooting](#)

How to Use

What You Can Do

Parts Description

Setup

Enjoying Music

Enjoying Videos / Photos

Application

Android

Connections

Settings

Other Operations

Notifications

Announcements

Adding Wi-Fi networks manually

You can add a Wi-Fi network manually if the Wi-Fi network you want to use is not detected automatically when Wi-Fi is on.

1. Tap the (Menu) button with the Home screen displayed, then tap [Settings] - [Wireless & networks] - [Wi-Fi settings] - [Add Wi-Fi network].
2. Enter the network SSID of the network to use.
3. Enter a password if needed, and tap [Save].

Hint

- To check the MAC address of your "WALKMAN" or other Wi-Fi details, tap the (Menu) button when in [Wi-Fi settings] and tap [Advanced].

Related topic

[Turning Wi-Fi on and off](#)

[Notes on Wi-Fi](#)



▶ Troubleshooting

How to Use

What You Can Do

Parts Description

Setup

Enjoying Music

Enjoying Videos / Photos

Application

Android

Connections

Settings

Other Operations

Notifications

Announcements

Checking Wi-Fi network status

You can check the status of a Wi-Fi network by icons shown in the status bar.

	Connected to a Wi-Fi network.
	An open network is detected (when Wi-Fi network notification is set to on).

Related topic

[Connecting to a Wi-Fi network](#)

[Notes on Wi-Fi](#)

[▶ Troubleshooting](#)

How to Use

What You Can Do

Parts Description

Setup

Enjoying Music

Enjoying Videos / Photos

Application

Android

Connections

Settings

Other Operations

Notifications

Announcements

Connecting to a Wi-Fi network

Search for a usable Wi-Fi network, and connect to that network.

1. Tap the (Menu) button with the Home screen displayed, then tap [Settings] - [Wireless & networks] - [Wi-Fi settings] - [Wi-Fi].
2. Tap the access point to use from the network list.
3. Enter a password if needed, and tap [Connect].

Hint

- When you are in range and [Wi-Fi] is on, your "WALKMAN" will automatically reconnect to available networks to which you have connected before.
- To check the MAC address of your "WALKMAN" or other Wi-Fi details, tap the (Menu) button when in [Wi-Fi settings] and tap [Advanced].

Note

- Please contact the manufacturer of your Wi-Fi device for information such as how to set the access point.

Related topic

[About Wi-Fi communications](#)

[Turning Wi-Fi on and off](#)

[Notes on Wi-Fi](#)



▶ Troubleshooting

How to Use

What You Can Do

Parts Description

Setup

Enjoying Music

Enjoying Videos / Photos

Application

Android

Connections

Settings

Other Operations

Notifications

Announcements

Notes on Wi-Fi

The following are notes regarding use of Wi-Fi.

- Use of Wi-Fi products may be restricted by local regulations in some countries or regions.
- Wi-Fi devices work on the 2.4 GHz band, which is used by a variety of devices. Wi-Fi devices use technology to minimize radio interference from other devices that use the same band. However, radio interference may still cause slower data transfer rates, reduce communications range, or cause communications failure.
- If both the Wi-Fi function and the Bluetooth function of your "WALKMAN" are enabled, interference may occur and cause slower data transfer rates or other problems.
- To communicate via Wi-Fi while traveling, you may need to contract with a Wi-Fi connection service provider.
- Data transfer rate and communications range may vary depending on the following conditions.
 - Distance between devices
 - Presence of obstacles between devices
 - Device configuration
 - Signal conditions
 - Surrounding environment (wall material, etc.)
 - Software in use
- Communications may be cut off depending on signal conditions.
- The data transfer rate specified in the specifications is the theoretical maximum, and it may not reflect actual data transfer rate.
- Actual data transfer rate may not be as fast as the rate displayed on the screen.
- Communications is not available with 5 GHz Wi-Fi as it uses a different frequency band.
- The data transfer rate for IEEE 802.11g and IEEE 802.11n (2.4 GHz) devices may be affected by interference when used with IEEE 802.11b products. Also, products using IEEE 802.11g and IEEE 802.11n automatically lower the transfer rate to maintain compatibility with IEEE 802.11b products. The normal transfer rate may be regained by changing the channel settings of your access point.
- When the data transfer rate is not as fast as expected, changing the wireless channel on the access point may increase the rate.
- The Wi-Fi antenna is built in to your "WALKMAN." If you cover the antenna with your hands or other objects while using the Wi-Fi function, the Wi-Fi connection may deteriorate.

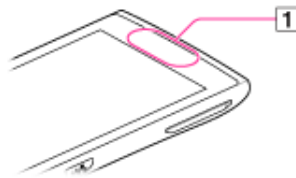

1 Built-in antenna

[▶ Troubleshooting](#)

How to Use

[What You Can Do](#)
[Parts Description](#)
[Setup](#)
[Enjoying Music](#)
[Enjoying Videos / Photos](#)
[Application](#)
[Android](#)
[Connections](#)
[Settings](#)
[Other Operations](#)
[Notifications](#)
[Announcements](#)

Turning Wi-Fi on and off

To use Wi-Fi communications with your "WALKMAN," first turn on the Wi-Fi function.

1. Tap the (Menu) button with the Home screen displayed, then tap [Settings] - [Wireless & networks] - [Wi-Fi].

A checkmark will be added, and the Wi-Fi function will turn on.

Tapping [Wi-Fi] again will remove the checkmark, and the Wi-Fi function will turn off.

Note

- To reduce battery consumption, turn off the Wi-Fi function when not in use.
- The Wi-Fi antenna is built in to your "WALKMAN." If you cover the antenna with your hands or other objects while connecting to the Internet using the Wi-Fi function, the communications quality may deteriorate. [\[Details\]](#)

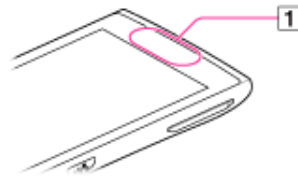

1 Built-in antenna

Related topic

[About Wi-Fi communications](#)
[Connecting to a Wi-Fi network](#)
[Checking Wi-Fi network status](#)
[Notes on Wi-Fi](#)



▶ Troubleshooting

How to Use

What You Can Do

Parts Description

Setup

Enjoying Music

Enjoying Videos / Photos

Application

Android

Connections

Settings

Other Operations

Notifications

Announcements

About DLNA

Connect your "WALKMAN" to your home network to play back content stored on another DLNA certified device (server) on your "WALKMAN," or to play back content stored on your "WALKMAN" on another DLNA certified device (playback device).



Devices that can act as a server

DLNA certified computer, DLNA certified audio device, etc.

Devices that can act as a playback device

DLNA certified TV, DLNA certified computer, etc.

Hint

- DLNA is an abbreviation for Digital Living Network Alliance. The word DLNA indicates the organization, which is developing guidelines for transferring digital content such as music or images via the home network, and the embodying system itself.

Playing back content stored on another device (server)



You can play back content such as photos, music, or videos stored on a DLNA certified server (computer, etc.) on your "WALKMAN," by connecting to that server.

Sending (throwing) content to other devices (playback devices) and playing it back



You can play back content such as photos, music, or videos stored on your “WALKMAN” by sending it to another device (playback device.)

Hint

- Content stored on a server on your home network can also be sent to another device (playback device) and played back.

Related topic

[Connecting DLNA devices](#)

[Playing back content stored on another device](#)

[Sending content to other devices and playing it back](#)

[▶ Troubleshooting](#)**How to Use****What You Can Do****Parts Description****Setup****Enjoying Music****Enjoying Videos / Photos****Application****Android****Connections****Settings****Other Operations****Notifications****Announcements****Connecting DLNA devices**

Connect the DLNA certified devices to the home network by the following procedure.

Example: When you use a computer as a server and a TV as a playback device

1. Connect the computer that will act as a server to the home network.
For details on DLNA settings, see the operating instructions supplied with the computer.
2. Connect the TV that will act as a playback device to which content is sent to the home network.
For details on DLNA settings, see the operating instructions supplied with the playback device.
3. Connect your "WALKMAN" to the home network.

Note

- Depending on the server or playback device, you may need to register your "WALKMAN" or the playback device with the server. Otherwise, the content list of the server or content sent to the playback device will not be displayed, causing an error on the playback device. For details, see the operating instructions supplied with the devices.

Related topic[About DLNA](#)[Playing back content stored on another device](#)[Sending content to other devices and playing it back](#)



▶ Troubleshooting

How to Use

What You Can Do

Parts Description

Setup

Enjoying Music

Enjoying Videos / Photos

Application

Android

Connections

Settings

Other Operations

Notifications

Announcements

Playing back content stored on another device

You can play back content such as photos, music, or videos stored on a server [\[Details\]](#), on your "WALKMAN." You must make preparations in advance to use the home network.

[\[Details\]](#)

1. From the Home screen, tap [\[Apps\]](#) - [\[DLNA\]](#).

When you start the application for the first time:

A screen appears to explain what you can do and to describe the preparations needed.

If you have used the application before:

Servers are automatically searched for, and the server list is displayed.

2. Tap the icon of the server holding the content you want to play back.
3. Tap a list item, folder, etc. to select the content that you want to play back. An application that supports the content launches and playback starts.

Note

- If you select content in a file format that is not supported by your "WALKMAN," the content cannot be played back.

Hint

- The folders selected to reach the current folder are listed in order under the server list. You can return to previous folders by tapping items in the list.
- If the server cannot be found in step 2, refresh the server list from the option menu.

To bookmark folders or content

Tap [★](#) displayed at the right of each folder or content item that you want to bookmark.

To delete a bookmark

Press and hold the bookmark that you want to delete from the bookmark list, and then tap [\[Delete bookmark\]](#).



1 Bookmarks

2 Open/close bookmarks

Hint

- Up to 100 bookmarks can be registered for servers in total.

Related topic

[About DLNA](#)

[Connecting DLNA devices](#)

[Sending content to other devices and playing it back](#)

© 2012 Sony Corporation



▶ Troubleshooting

How to Use

What You Can Do

Parts Description

Setup

Enjoying Music

Enjoying Videos / Photos

Application

Android

Connections

Settings

Other Operations

Notifications

Announcements

Sending content to other devices and playing it back

Send (Throw) video, photo or music content that can be played back on your "WALKMAN," to another device (playback device) on the home network and play back on that device.

[\[Details\]](#)

You can use this function with the Video player (video), Photo viewer (photo), Music player (music), and DLNA applications.

You must make preparations in advance to use the home network. [\[Details\]](#)

1. Tap the content you want to send to and play back on another device.
Playback of the content starts.
2. Tap [ Throw].
3. Tap the icon of the device that you want to send the content to, from the displayed icon list of playback devices.
Playback starts on the selected playback device. You can control playback using your "WALKMAN."

Note

- If you send (Throw) the content in a file format that is not supported by another device (playback device) on the home network, the content cannot be played back.
- If you display another screen while you are controlling another device (playback device) using your "WALKMAN," return to the control screen via the notification panel.
- Copyright-protected content cannot be sent (Throw) to and played back on another device (playback device).

Hint

- You can also select and play back content stored on another device (server) using the DLNA application [\[Details\]](#) and proceed to step 2.
- When you tap [Throw] in the menu displayed by pressing and holding the content list in the DLNA, Video player or Music player application, you can proceed to step 3 without playback.
- While you are sending content to another device, you can play back other content on your "WALKMAN."

Related topic

[About DLNA](#)

[Connecting DLNA devices](#)

[Playing back content stored on another device](#)

[▶ Troubleshooting](#)**How to Use**

What You Can Do

Parts Description

Setup

Enjoying Music

Enjoying Videos / Photos

Application

Android

Connections

Settings

Other Operations

Notifications

Announcements

About the location information

The location information function finds your current position using GPS* or a wireless network (Wi-Fi).

Using GPS allows you to find your position accurately, even if the process does take some time. Using a wireless network allows you to find your position quickly, but accuracy may vary.

Using GPS and a wireless network together allows you to make the most of the merits of both methods.

* GPS stands for Global Positioning System. GPS satellites emit positioning signals toward the earth, and your "WALKMAN" uses those to display your current position.

Related topic

[Enabling/disabling use of location information](#)

[Setting to search for your current position with a wireless network](#)

[Notes on the GPS function](#)



▶ Troubleshooting

How to Use

What You Can Do

Parts Description

Setup

Enjoying Music

Enjoying Videos / Photos

Application

Android

Connections

Settings

Other Operations

Notifications

Announcements

Enabling/disabling use of location information

Set permission to use your current position information from the GPS function or wireless network (Wi-Fi) with applications that use location information (Google Maps, etc.).

1. Tap the (Menu) button with the Home screen displayed, then tap [Settings] - [Location & security].
2. To set the wireless network, tap [Use wireless networks]. To set the GPS function, tap [Use GPS satellites].
Use of location information is enabled/disabled each time you tap the setting.

Note

- Move your "WALKMAN" as little as possible in an area where there are no tall buildings and trees around until the present location is displayed by the GPS function. The present location can be displayed quicker when stationary than while moving. If the present location is not displayed or if the wrong location is displayed, move your "WALKMAN" to an area where there are no tall buildings and trees around.
- You can reduce battery consumption by turning off the GPS function when not using that function.

Related topic

[About the location information](#)

[Setting to search for your current position with a wireless network](#)

[Notes on the GPS function](#)

[▶ Troubleshooting](#)**How to Use****What You Can Do****Parts Description****Setup****Enjoying Music****Enjoying Videos / Photos****Application****Android****Connections****Settings****Other Operations****Notifications****Announcements****Notes on the GPS function**

The following are notes regarding use of the GPS function.

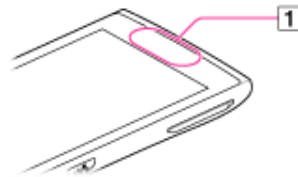

- When other electronic devices are near your "WALKMAN," electromagnetic waves or magnetic interference from those may prevent your "WALKMAN" from providing accurate location information. Keep electronic devices away from your "WALKMAN."
- When in an area with poor reception of GPS signals, you may encounter positioning errors. To receive more accurate information, avoid using your "WALKMAN" in the following locations.
 - Inside buildings and in vehicles such as cars and trains
 - In tunnels or underground
 - Under elevated tracks
 - Between tall buildings
 - In dense trees
 - In valleys
- The GPS antenna is built in to your "WALKMAN." If you cover the antenna with your hands or other objects while using the GPS function, the positioning accuracy may deteriorate.



1 Built-in antenna

[▶ Troubleshooting](#)**How to Use**[What You Can Do](#)[Parts Description](#)[Setup](#)[Enjoying Music](#)[Enjoying Videos / Photos](#)[Application](#)[Android](#)[Connections](#)[Settings](#)[Other Operations](#)[Notifications](#)[Announcements](#)**Setting to search for your current position with a wireless network**

Set to search for your current position with a wireless network.

1. Tap the  (Menu) button with the Home screen displayed, then tap [ Settings] - [ Location & security] - [Use wireless networks].
2. Read the cautions about location information, and tap [Agree].

Note

- Location information is collected without identifying the individual user. Also, location information may be collected even if the application is not running.

Related topic[About the location information](#)[Enabling/disabling use of location information](#)

[▶ Troubleshooting](#)**How to Use**

What You Can Do

Parts Description

Setup

Enjoying Music

Enjoying Videos / Photos

Application

Android

Connections

Settings

Other Operations

Notifications

Announcements

About the Help guide

This Help guide covers items such as detailed operations for your “WALKMAN” and explanations of applications.

Items such as operation procedures are separated into topics for easy searching.

Help guide (for viewing on your “WALKMAN” screen) [\[Details\]](#)

Help guide (for viewing on a computer screen) [\[Details\]](#)

Note

- The screens herein are for descriptive purposes, and they may differ from the actual screen.

Related topic

[About the “WALKMAN” manuals](#)

[▶ Troubleshooting](#)**How to Use**

What You Can Do

Parts Description

Setup

Enjoying Music

Enjoying Videos / Photos

Application

Android

Connections

Settings

Other Operations

Notifications

Announcements

About Media Go

Media Go is software that allows you to copy (import) music from your CDs to your computer and to manage the stored content on your computer.

You can transfer content stored on your computer to your "WALKMAN" using Media Go. If you have already managed music with iTunes, etc., you can use Media Go to transfer content to your "WALKMAN." You can also use the Windows Explorer to drag-and-drop content to Media Go.

Related topic[Importing music from CDs using Media Go](#)[Transferring content using Media Go](#)



▶ Troubleshooting

How to Use

What You Can Do

Parts Description

Setup

Enjoying Music

Enjoying Videos / Photos

Application

Android

Connections

Settings

Other Operations

Notifications

Announcements

Importing music from CDs using Media Go

Use Media Go to copy (import) music from your CDs.



Hint

- For details about how to use Media Go, refer to the help guide of Media Go.

1. Start up Media Go, and then insert an audio CD.

Media Go detects the CD and displays a window for CD information. When Media Go obtains the CD information (CD title, song name, artist name, etc.), it is displayed in the window.

2. Click **1**.

Wait until all songs have been imported.

Hint

- Recommended file formats for ripping CDs are AAC (.mp4) and MP3 (.mp3). You can transfer music more effectively to your "WALKMAN" using those formats.
- Media Go obtains the CD information from a database on the Internet. However, depending on the CD, information may not be available in the database. If a CD's information is missing, you can add it after importing. For information about adding and editing CD information, refer to the help guide of Media Go.

Note

- Imported songs are limited to private use only. Use of a song beyond this limitation requires permission of the copyright holders.

Related topic

[About Media Go](#)

[Transferring content using Media Go](#)



▶ Troubleshooting

How to Use

What You Can Do

Parts Description

Setup

Enjoying Music

Enjoying Videos / Photos

Application

Android

Connections

Settings

Other Operations

Notifications

Announcements

Transferring content using Media Go

Transfer content stored on your computer to your "WALKMAN" using Media Go 2.0.

Note

- Media Go does not support content that uses digital rights management technology ("WM-DRM") for Windows Media.
- Content with copyright protection cannot be transferred.
- Media Go supports data transferred from iTunes to your "WALKMAN."

Transferring content managed with Media Go

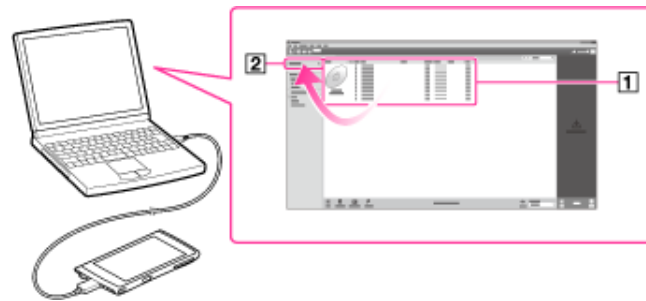

1. Connect your "WALKMAN" and your computer using the USB cable (supplied) [\[Details\]](#), and then start Media Go.
2. Select the desired content (**1**), and drag-and-drop it to your "WALKMAN" (**2**).
Media Go recognizes the type of data by filename extension, and sends it to the appropriate folder of your "WALKMAN."

Transferring content managed with iTunes, etc.

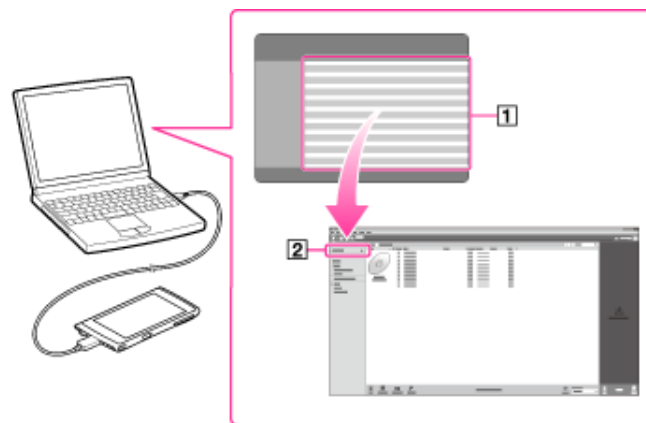

1. Connect your "WALKMAN" and your computer using the USB cable (supplied) [\[Details\]](#), and then start Media Go.
2. Start iTunes, etc.
3. Select the desired content from iTunes, etc. (**1**), and drag-and-drop it to your "WALKMAN" (**2**).
Media Go recognizes the type of data by filename extension, and sends it to the appropriate folder of your "WALKMAN."

Related topic

[About Media Go](#)

[Importing music from CDs using Media Go](#)

© 2012 Sony Corporation

[▶ Troubleshooting](#)**How to Use**

What You Can Do

Parts Description

Setup

Enjoying Music

Enjoying Videos / Photos

Application

Android

Connections

Settings

Other Operations

Notifications

Announcements

About Photo viewer

In addition to viewing photos imported to your "WALKMAN" and enjoying slide shows, the Photo viewer application on your "WALKMAN" allows you to add tags to photos [\[Details\]](#) and easily share photos with other devices on the home network. [\[Details\]](#)

1. From the Home screen, tap [ Apps] - [ Photo viewer].

Related topic[How to use the photo screen](#)[Viewing photos](#)[Dragging and dropping data to a computer with USB connection](#)



▶ Troubleshooting

How to Use

What You Can Do

Parts Description

Setup

Enjoying Music

Enjoying Videos / Photos

Application

Android

Connections

Settings

Other Operations

Notifications

Announcements

Adding tags to photos

You can add, edit, and delete tags for photos with Photo viewer on your “WALKMAN.”

1. From the Home screen, tap [Apps] - [Photo viewer].
2. Tap displayed on the top left of the screen.
The top screen of Photo viewer is displayed.
3. Tap [Add tags].
4. Tap the tag of your choice, then tap the photo to add the tag to.

Hint

- To create new tags, tap the (Menu) button, then tap [Add tag].
- To edit tags, tap the tag to edit, tap the (Menu) button, then tap [Edit tag name].
- To delete tags, tap the tag to delete, tap the (Menu) button, then tap [Delete tag].

Related topic

[Viewing photos](#)

[Changing Photo viewer settings](#)



▶ Troubleshooting

How to Use

What You Can Do

Parts Description

Setup

Enjoying Music

Enjoying Videos / Photos

Application

Android

Connections

Settings

Other Operations

Notifications

Announcements

Changing Photo viewer settings

You can configure the settings for Photo viewer.

Items displayed differ depending on the screen.

1. From the Home screen, tap [Apps] - [Photo viewer].
2. Tap displayed on the top left of the screen.
The top screen of Photo viewer is displayed.
3. Tap the (Menu) button, then tap [Settings].
The following items can be set.

Display tags:

Displays tags on the thumbnails.

Display zoom slider:

Displays a slider for changing the thumbnail size.

Slideshow interval settings:

Sets the interval between photos in slide shows.

Play continuously:

Repeats slide show playback.

Update database:

Searches for photo files on your "WALKMAN," and registers them to a database.

About Photo viewer:

Displays version information, etc.

Related topic

[Adding tags to photos](#)

[▶ Troubleshooting](#)**How to Use**

What You Can Do

Parts Description

Setup

Enjoying Music

Enjoying Videos / Photos

Application

Android

Connections

Settings

Other Operations

Notifications

Announcements

Deleting photos

Delete photos that are not needed.

1. From the Home screen, tap [Apps] - [Photo viewer].
2. Tap displayed on the top left of the screen.
The top screen of Photo viewer is displayed.
3. Tap the photo to delete.
4. Tap the (Menu) button, then tap [Remove] - [OK].

Related topic

[Viewing photos](#)



NWZ-Z1040/Z1050/Z1060

[Back](#) | [Back to Top](#)

▶ Troubleshooting

How to Use

What You Can Do

Parts Description

Setup

Enjoying Music

Enjoying Videos / Photos

Application

Android

Connections

Settings

Other Operations

Notifications

Announcements

How to use the photo screen

The following explains the photo screen.

Photo display screen



1. Photo file name
2. Throw [\[Details\]](#)
3. Start/stop slide show playback [\[Details\]](#)

Operations on the photo display screen



Tap to start slide show playback. Tap the screen to stop playback.



Tap to display the next photo.



Tap to display the previous photo.

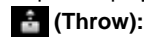

Tap to send the photo to another device (Throw) and play it back there. [\[Details\]](#)



Tap to return to the top screen of Photo viewer.

Hint

- Display turns off if no operations are made for a certain amount of time. To display again, tap the screen.

List screen



1. Slide show
2. Add tags [\[Details\]](#)
3. Switch view
4. Folder name
5. Photo thumbnail
6. Zoom in/out thumbnail

Related topic

[Viewing photos](#)

[Changing Photo viewer settings](#)

[▶ Troubleshooting](#)

How to Use

What You Can Do

Parts Description

Setup

Enjoying Music

Enjoying Videos / Photos

Application

Android

Connections

Settings

Other Operations

Notifications

Announcements

Viewing photos

Display photos with Photo viewer on your "WALKMAN."

1. From the Home screen, tap [Apps] - [Photo viewer].
2. Tap [] displayed on the top left of the screen.
The top screen of Photo viewer is displayed.
3. Tap the search method of your choice from [Tag name], [Folders], rating order (available only when you have rated) etc.
4. Tap the photo to display.

Hint

- Pinch in or pinch out on the displayed photo to zoom in or out.
- Rotate the displayed photo by placing two fingers on the photo and moving them in a rotating motion.
- Tap [] while a photo is displayed to play a slide show.

Related topic

[Adding tags to photos](#)

[Changing Photo viewer settings](#)

[Supported formats](#)

[▶ Troubleshooting](#)

How to Use

What You Can Do

Parts Description

Setup

Enjoying Music

Enjoying Videos / Photos

Application

Android

Connections

Settings

Other Operations

Notifications

Announcements

About SensMe™ channels

“SensMe™ channels” is a function that automatically sorts music content into channels according to the music type. You can select the channel according to the atmosphere or your mood.

Hint

- SensMe™ channels is achieved by the following technologies.
 - Music file transfer from software and devices that support 12 TONE ANALYSIS technology developed by Sony
 - 12 TONE ANALYSIS on your “WALKMAN” by Low-Complexity Music Information Retrieval technology developed by Sony [\[Details\]](#)
- Using Media Go allows for transfer of music upon conducting 12 TONE ANALYSIS for SensMe™ channels playback on your “WALKMAN.”

Related topic

[Playing songs using SensMe™ channels](#)

[Analyzing songs on your “WALKMAN”](#)



▶ Troubleshooting

How to Use

What You Can Do

Parts Description

Setup

Enjoying Music

Enjoying Videos / Photos

Application

Android

Connections

Settings

Other Operations

Notifications

Announcements

Analyzing songs on your "WALKMAN"

Songs that were not analyzed by software on a computer using 12 TONE ANALYSIS can be analyzed on your "WALKMAN."

1. From the Home screen, tap [Apps] - [Music player] - [SensMe™ channels].

Hint

- If the music playback screen is displayed, tap the screen then , , or displayed at the top left of the screen. Then tap [SensMe™ channels].
2. Press the (Menu) button, then tap [Music analyzer].
Your "WALKMAN" will start analyzing. When analysis is complete, display will be returned to the SensMe™ channels screen.

To stop analyzing

Tap [Stop] while analyzing. Songs analyzed up to the point where you stopped analyzing will be playable by SensMe™ channels.

Note

- Your "WALKMAN" analyzes all not-yet analyzed songs at once. You cannot analyze songs individually.
- The results of the analysis may vary between your "WALKMAN," Media Go, and other devices that can perform analysis.

Related topic

[About SensMe™ channels](#)

[Playing songs using SensMe™ channels](#)



▶ Troubleshooting

How to Use

What You Can Do

Parts Description

Setup

Enjoying Music

Enjoying Videos / Photos

Application

Android

Connections

Settings

Other Operations

Notifications

Announcements

Playing songs using SensMe™ channels

You can play songs to fit conditions such as the atmosphere, your mood, or time of day by selecting a particular channel.

1. From the Home screen, tap [Apps] - [Music player] - [SensMe™ channels].

Hint

- If the music playback screen is displayed, tap the screen then , , or displayed at the top left of the screen. Then tap [SensMe™ channels].
2. Drag the screen up or down or flick the screen to select a channel.



Hint

- Each time you select a channel, the order of playback will vary.
- If you change channels, the first song is played back from the most melodic and rhythmical section.

Note

- Depending on the file format, certain songs cannot be analyzed even by software that supports 12 TONE ANALYSIS. If that case, select [Music analyzer] on the options menu of your "WALKMAN" to analyze. [\[Details\]](#)
- Some songs may be added to several channels or not selected at all. However, all songs can be played back using [Shuffle All].

[Morning] (05:00-09:59):

Plays music for various times of the day.

[Daytime] (10:00-15:59):

Plays music for various times of the day.

[Evening] (16:00-18:59):

Plays music for various times of the day.

[Night] (19:00-23:59):

Plays music for various times of the day.

[Midnight] (24:00-04:59):

Plays music for various times of the day.

[Shuffle All]:

Plays all songs in random order.

[Energetic]:

Plays uptempo and high-energy music.

[Relax]:

Plays calm and relaxing music.

[Upbeat]:

Plays cheerful and uplifting music.

[Mellow]:

Plays soft and slow-tempo music.

[Lounge]:

Plays jazz and easy listening music.

[Emotional]:

Plays ballads.

[Dance]:

Plays rhythm, rap and R & B music.

[Extreme]:

Plays loud and powerful music.

Related topic

[About SensMe™ channels](#)

[Analyzing songs on your "WALKMAN"](#)

[▶ Troubleshooting](#)**How to Use****What You Can Do****Parts Description****Setup****Enjoying Music****Enjoying Videos / Photos****Application****Android****Connections****Settings****Other Operations****Notifications****Announcements****About Video player**

In addition to viewing videos, the Video player application on your “WALKMAN” allows you to easily search for the scene you want to watch [\[Details\]](#) and easily share videos with other devices on the home network. [\[Details\]](#)

1. From the Home screen, tap [ Apps] - [ Video player].

Related topic[How to use the video playback screen](#)[Playing back videos](#)



▶ Troubleshooting

How to Use

What You Can Do

Parts Description

Setup

Enjoying Music

Enjoying Videos / Photos

Application

Android

Connections

Settings

Other Operations

Notifications

Announcements

Changing Video player settings

You can configure various settings for using Video player.
Items displayed differ depending on the screen.

1. From the Home screen, tap [Apps] - [Video player].
2. Tap the (Menu) button.
The following items can be set.

Items displayed on the video list screen

Video list sort order:

Changes the display order.

Settings:

Configures detailed settings such as audio.

Items displayed on the video playback screen

Audio options:

Switches the audio.

Details:

Displays detailed information about the content playing.

Delete:

Deletes the content playing.

Settings:

Configures detailed settings such as audio.

Items displayed on the detailed information screen

Settings:

Configures detailed settings such as audio.

Related topic

[Playing back videos](#)

[▶ Troubleshooting](#)**How to Use**

What You Can Do

Parts Description

Setup

Enjoying Music

Enjoying Videos / Photos

Application

Android

Connections

Settings



Other Operations

Notifications

Announcements

Deleting videos

Delete videos that are not needed.

1. From the Home screen, tap [ Apps] - [ Video player].
2. Select items from the list until the video you want to delete is displayed. [\[Details\]](#)
3. Tap the  (Menu) button with the video playback screen displayed, then tap [Delete] - [OK].

Related topic

[Playing back videos](#)



▶ Troubleshooting

How to Use

What You Can Do

Parts Description

Setup

Enjoying Music

Enjoying Videos / Photos

Application

Android

Connections

Settings

Other Operations

Notifications

Announcements

Finding scenes from video thumbnails

You can display thumbnails for a video and select the scene or chapter you want to play.

1. From the Home screen, tap [Apps] - [Video player].
2. Tap [Scene search] with the video playback screen displayed.
3. Drag or flick the screen to go to the previous/next thumbnail.



1 Scene setting item

You can set the interval at which thumbnails are displayed.

Select from [15 sec.], [30 sec.], [1 min.], [2 min.], [5 min.], or [Chapter] (only for videos with chapters).

4. Tap the scene of your choice.

To go back to the original video playback screen during operations

1. Tap the (Back) button.

Related topic

[Playing back videos](#)

[Selecting videos](#)



▶ Troubleshooting

How to Use

What You Can Do

Parts Description

Setup

Enjoying Music

Enjoying Videos / Photos

Application

Android

Connections

Settings

Other Operations

Notifications

Announcements

How to use the video playback screen

The following explains the video playback screen.

Note

- Your "WALKMAN" displays in landscape when playing videos.

Video playback screen



1. Video list
2. Content title
3. Throw [\[Details\]](#)
4. Playback status display
5. Elapsed time
6. Scene search [\[Details\]](#)
7. Total time
8. Timeline bar

Operations on the video playback screen

(*1):

Tap to play/pause.

:

Tap or press and hold to fast forward/fast reverse (*2).

:

Press and hold to fast forward/fast reverse (*3).

Tap to skip forward/back slightly.

:

Tap to jump to the previous/next scene (*4) or chapter.

Timeline bar:

Drag the indicator (playback point) to quickly change the playback point.

(Throw):

Tap to send the video to another device (Throw) and play it back on that device. [\[Details\]](#)

(Scene search):

Tap to display the thumbnails and select the scene or chapter to play (Scene search).

[\[Details\]](#)

[Video list]:

Tap to go back to the video list screen.

(*1) The screen turns off automatically if operations are not made for a certain amount of time while paused.

(*2) Repeatedly tapping or during fast forward or fast reverse switches to fast playback with sound (x1.5 (1.5 times)), three speed levels of fast forward (x10 (10 times), x30 (30 times), x100 (100 times)) or three speed levels of reverse (x10 (10 times), x30 (30 times), x100 (100 times)). Tap to resume normal playback.

(*3) Fast forward/fast reverse speed while paused differs depending on the video length.

(*4) The scene jumps back/forward in 5 min. increments if chapters are not set in the video.

Hint

- Control buttons turn off if no operations are made for a certain amount of time. To display again, tap the screen.

Video list screen

Hint

- You can switch between three types of video list screens: grid view, list view, and cover art view.



1. Switch filters
2. Video thumbnail
3. Video title
4. Total time
5. To playback screen
6. Switch view
7. Playback point indicator
8. Playing icon
9. Not viewed icon

Related topic

[Playing back videos](#)

[Changing Video player settings](#)

[▶ Troubleshooting](#)**How to Use****What You Can Do****Parts Description****Setup****Enjoying Music****Enjoying Videos / Photos****Application****Android****Connections****Settings****Other Operations****Notifications****Announcements****Playing back videos**

Play back videos with the video playback application on your "WALKMAN."

1. From the Home screen, tap [Apps] - [Video player].
2. Select items from the list until the video you want to play is displayed. [\[Details\]](#)

Hint

- Thumbnails can be added to video files which were transferred to the computer by drag and drop. Create thumbnails according to the rules below.
 - File must be in JPEG format.
 - Dimensions must be horizontal 160 × vertical 120 dots.
 - File name must be the same as the video file, with the extension ".jpg."
 - The thumbnail and video file must be placed in the same folder of your "WALKMAN."
- Videos are played back one by one, not continuously.

Related topic[Finding scenes from video thumbnails](#)[Selecting videos](#)[Changing Video player settings](#)[Supported formats](#)

[▶ Troubleshooting](#)**How to Use**

What You Can Do

Parts Description

Setup

Enjoying Music

Enjoying Videos / Photos

Application

Android

Connections

Settings

Other Operations

Notifications

Announcements

Selecting videos

You can change the order that videos are displayed on the list screen and quickly select videos.

1. From the Home screen, tap [Apps] - [Video player].
2. From the list screen, tap the (Menu) button, then tap [Video list sort order].
3. Select the search method of your choice.

Hint

- The display order of the video list can be rearranged by the date that the videos were transferred or the title of the videos.

Related topic[Playing back videos](#)[Finding scenes from video thumbnails](#)

[▶ Troubleshooting](#)**How to Use**[What You Can Do](#)[Parts Description](#)[Setup](#)[Enjoying Music](#)[Enjoying Videos / Photos](#)[Application](#)[Android](#)[Connections](#)[Settings](#)[Other Operations](#)[Notifications](#)[Announcements](#)**Using the Home, Menu, and Back buttons**

The following explains the physical buttons on your "WALKMAN."



1. (Back) button
 - Returns to the previous screen.
 - Closes dialog boxes, option menu, etc.
 - Closes the onscreen keyboard if it is displayed.
2. (Home) button
 - Returns to the Home screen.
 - Opens the screen of the previously used application when pressed and held.
3. (Menu) button
 - Opens the option menu.
 - Displays/hides the onscreen keyboard when pressed and held during text input.

Related topic[Parts and controls](#)

[▶ Troubleshooting](#)**How to Use**[What You Can Do](#)[Parts Description](#)[Setup](#)[Enjoying Music](#)[Enjoying Videos / Photos](#)[Application](#)[Android](#)[Connections](#)[Settings](#)[Other Operations](#)[Notifications](#)[Announcements](#)**Resetting**

You can reset your "WALKMAN" if operations become unstable.

1. Press the RESET button with the end of a pin or other narrow object.

Note

- To reset your "WALKMAN" safely, make sure that a song or a video is not being played before pressing the RESET button.

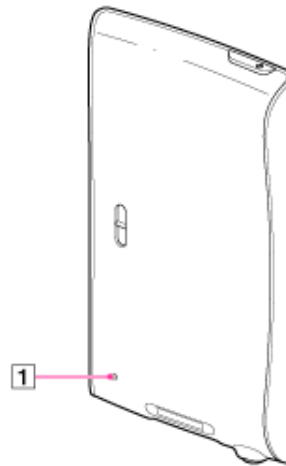

1 RESET button

Note

- No data or settings will be deleted by pressing the RESET button.
- Data and settings in use may not be saved when you press the RESET button.

Related topic[Parts and controls](#)[Initializing](#)



▶ Troubleshooting

How to Use

What You Can Do

Parts Description

Setup

Enjoying Music

Enjoying Videos / Photos

Application

Android

Connections

Settings

Other Operations

Notifications

Announcements

Using the W.button

You can press the  (Double-u Dot) button to control music playback without starting the Music player application, even in situations such as when using other applications or when the screen is locked. The display (element) screen for that playback control is called W.control.

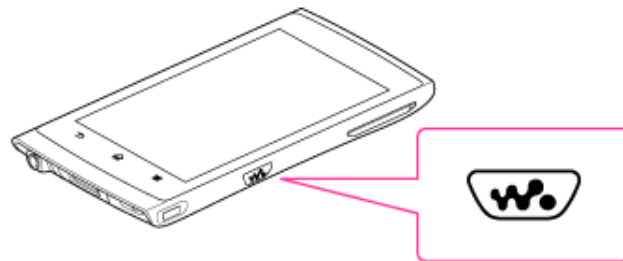

1. Press the  (Double-u Dot) button.



The W.control is displayed on the screen.

Press the button again to turn off the W.control.

Hint

- You can also turn off the control panel by tapping the  (Back) or  (Home) button.
- The W.control may not be displayed while using some of the applications (games etc.).

Related topic

[Parts and controls](#)

[How to use the W.control](#)

[Setting the W.control](#)

[About Music player](#)



▶ Troubleshooting

How to Use

What You Can Do

Parts Description

Setup

Enjoying Music

Enjoying Videos / Photos

Application

Android

Connections

Settings

Other Operations

Notifications

Announcements

How to use the W.control

On the W.control, you can control song playback by operating buttons on the screen or by gestures.

W.control (Button operation screen)

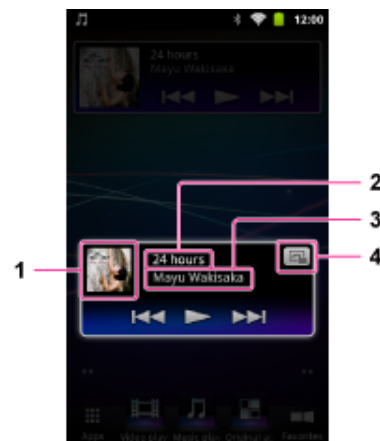

1. Cover art
2. Song name
3. Artist name
4.  (Operation method switching)
Tap to switch to gesture operation screen.

Operations on the W.control (Button operation screen)



Tap to play/pause.

Cover art:

Tap to start Music player. (*1)



Tap to go to beginning of previous (or current)/next song.

(*1) Music player will not start if the screen is locked.

W.control (Gesture operation screen)

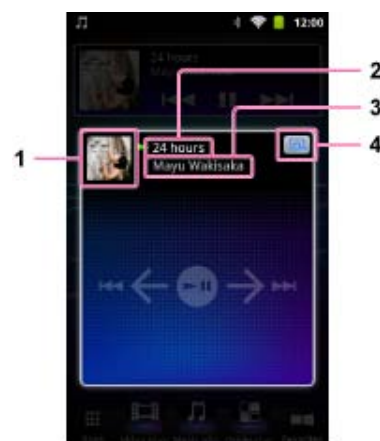

1. Cover art

2. Song name
3. Artist name
4.  (Operation method switching)
Tap to switch to button operation screen.

Operations on the W.control (Gesture operation screen)

Tap on W.control:

Plays/pauses.

Tap cover art:

Starts Music player. (*1)

Flick left/right on W.control:

Goes to beginning of previous (or current)/next song.

(*1) Music player will not start if the screen is locked.

Hint

- Operations corresponding to gestures can be changed. [\[Details\]](#)

Related topic

[Using the W.button](#)

[Setting the W.control](#)

[About Music player](#)

[▶ Troubleshooting](#)

How to Use

What You Can Do

Parts Description

Setup

Enjoying Music

Enjoying Videos / Photos

Application

Android

Connections

Settings

Other Operations

Notifications

Announcements

Setting the W.control

Various settings can be made to use the W.control by gesture operations.

1. From the Home screen, tap [Apps] - [W.control].
2. Tap the item to set.
The following items can be set or confirmed.

Tapping:

Switches tap method to play/pause.

Flicking:

Switches the direction to flick to fast forward/fast rewind.

About W.control:

Displays version and other information.

Related topic

[Using the W.button](#)

[How to use the W.control](#)

[About Music player](#)

[▶ Troubleshooting](#)**How to Use**

What You Can Do

Parts Description

Setup

Enjoying Music

Enjoying Videos / Photos

Application

Android

Connections

Settings

Other Operations

Notifications

Announcements

Turning off the power



Turn off the power if you will not be using your "WALKMAN" for a long period of time.

1. Hold down the  (Power) button.
[Device options] will display.
2. Tap [Power off].
3. Tap [OK].
The power will then turn off.

Related topic[Turning on the power](#)[Turning the screen on and off](#)

[▶ Troubleshooting](#)**How to Use**[What You Can Do](#)[Parts Description](#)[Setup](#)[Enjoying Music](#)[Enjoying Videos / Photos](#)[Application](#)[Android](#)[Connections](#)[Settings](#)[Other Operations](#)[Notifications](#)[Announcements](#)**Turning on the power**

Turn on the power and start your "WALKMAN."

1. Hold down the  (Power) button.
The unlock screen will display.
2. Drag  from left to right.
Your "WALKMAN" is then unlocked, and the Home screen displays.

**Related topic**[Turning off the power](#)[Turning the screen on and off](#)[Charging the battery](#)

[▶ Troubleshooting](#)**How to Use**

What You Can Do

Parts Description

Setup

Enjoying Music

Enjoying Videos / Photos

Application

Android

Connections

Settings

Other Operations

Notifications

Announcements

Turning the screen on and off

You can turn off the screen when not using your “WALKMAN” in order to prevent the touch screen from being operated accidentally.

1. Press the  (Power) button.

The screen will turn off. Press the button again to turn the screen on.

Hint

- You can set the time that elapses before the screen turns off automatically.

Related topic[Turning on the power](#)[Turning off the power](#)

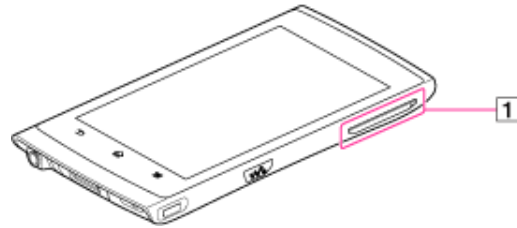

[▶ Troubleshooting](#)**How to Use**[What You Can Do](#)[Parts Description](#)[Setup](#)[Enjoying Music](#)[Enjoying Videos / Photos](#)[Application](#)[Android](#)[Connections](#)[Settings](#)[Other Operations](#)[Notifications](#)[Announcements](#)**Adjusting the volume**

Adjust the volume by the VOL (volume) +/- button on your "WALKMAN" or by the settings menu.



1 VOL (volume) +/- button

To adjust the volume by the settings menu

1. Tap the  (Menu) button with the Home screen displayed, then tap  [Settings] -  [Sound] - [Volume].
2. Drag the slider to adjust the individual volumes, then tap [OK].

Related topic[Parts and controls](#)[Using the speaker](#)



▶ Troubleshooting

How to Use

What You Can Do

Parts Description

Setup

Enjoying Music

Enjoying Videos / Photos

Application

Android

Connections

Settings

Other Operations

Notifications

Announcements

Parts and controls

Functions of buttons, jacks, and other parts on your "WALKMAN" are explained here.

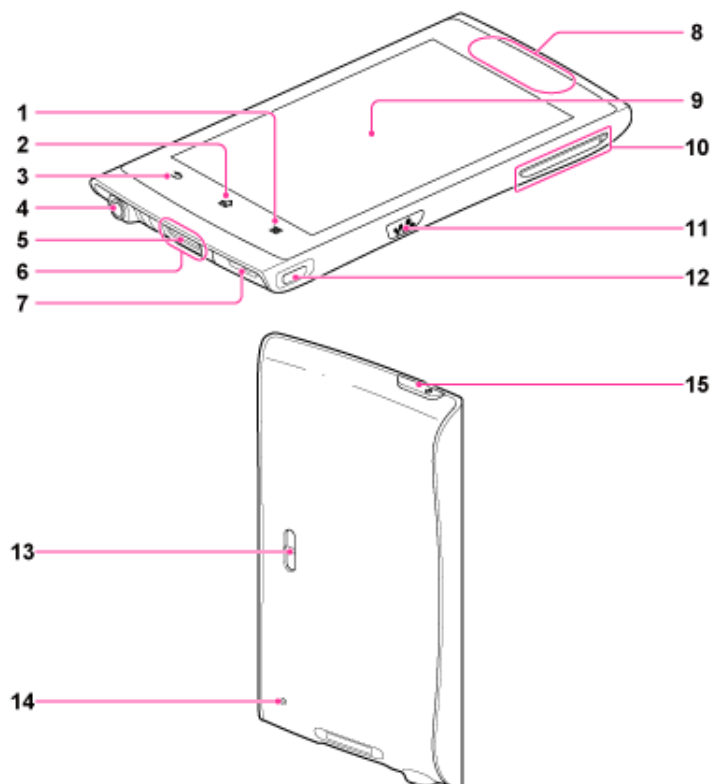

1. (Menu) button [\[Details\]](#)
2. (Home) button [\[Details\]](#)
3. (Back) button [\[Details\]](#)
4. Headphone jack
Insert the headphone plug until it clicks into place. If the headphones are connected improperly, the sound from the headphones will be impaired.
5. WM-PORT jack
Connect the USB cable (supplied) or other accessories that support WM-PORT (not supplied).
6. Built-in microphone
7. Strap hole
This is used to attach a strap (not supplied).
8. Built-in antenna
Wi-Fi, Bluetooth, and GPS antennas are built-in.
9. Screen (touch screen) [\[Details\]](#)
Touch (tap) icons, items, control buttons, etc., on the screen to operate your "WALKMAN."
10. VOL (Volume) +/- button
There is a tactile dot on the + button. Use it to help with button operations.
11. (Double-u Dot) button [\[Details\]](#)
This is used to display the W.control, on which you can control music playback directly.
12. HDMI jack [\[Details\]](#)

13. Speaker [\[Details\]](#)

14. RESET button [\[Details\]](#)

Press the RESET button with a small pin, etc., to reset your "WALKMAN."

15.  (Power) button [\[Details\]](#)

Related topic

[Contents](#)



▶ Troubleshooting

How to Use

What You Can Do

Parts Description

Setup

Enjoying Music

Enjoying Videos / Photos

Application

Android

Connections

Settings

Other Operations

Notifications

Announcements

About battery life

The time below may differ depending on ambient temperature or the status of use.

Battery Life (continuous playback)*

Actual battery life may vary depending on settings. The estimated battery usage hours shown below are based on typical usage conditions with "Settings for battery life measurement" as shown below.

Note

- Even if the player is turned off for an extended period, a small amount of battery power is still consumed.
- Battery life may vary depending on volume setting, conditions of use and ambient temperature.

Music

Bluetooth OFF

MP3 128 kbps:

Approx. 20 hours

WMA 128 kbps:

Approx. 13 hours

AAC-LC 128 kbps:

Approx. 18 hours

Linear PCM 1,411 kbps:

Approx. 23 hours

Bluetooth ON

MP3 128 kbps:

Approx. 14 hours

Video

Bluetooth OFF

MPEG-4 384 kbps:

Approx. 5 hours

AVC Baseline 384 kbps:

Approx. 6 hours

WMV 384 kbps:

Approx. 5 hours

Bluetooth ON

MPEG-4 384 kbps:

Approx. 5 hours

FM

Bluetooth OFF

Approx. 25 hours

Settings for battery life measurement

Common settings

Screen timeout (*1) (*2):

30 sec

Brightness (*3):

Default

Music settings

Equalizer (*4): [\[Details\]](#)

[None]

VPT (Surround) (*4): [\[Details\]](#)

[None]

DSEE (Sound enhance) (*4): [\[Details\]](#)

Off

Clear stereo (*4): [\[Details\]](#)

Off

Dynamic normalizer (*4): [\[Details\]](#)

Off

(*1) The off setting shortens the battery life about 80% compared with the [30sec] setting.

(*2) The longer the waiting time, the shorter the battery life for continuous music playback.

(*3) Maximum setting shortens the battery life for continuous video playback by about 45% compared with the default setting.

(*4) Setting [Equalizer] to other than [None], [VPT (Surround)] to other than [None], [DSEE (Sound enhance)] to on, [Clear stereo] to on, and [Dynamic normalizer] to on shortens the battery life for continuous music playback by about 50% compared with setting them to [None] or off.

Related topic

[Extending the battery life](#)

[▶ Troubleshooting](#)

How to Use

What You Can Do

Parts Description

Setup

Enjoying Music

Enjoying Videos / Photos

Application

Android

Connections

Settings

Other Operations

Notifications

Announcements

Charging the battery

Charge your "WALKMAN" by connecting it to a computer.

1. Use the supplied USB cable to connect your "WALKMAN" to a running computer. Plug in the USB cable with  facing upward.

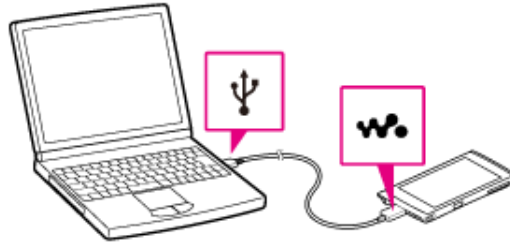

Hint

- You can also charge the battery with an AC adapter (not supplied) compatible with your "WALKMAN" (AC-NWUM60, etc.).
- When you use your "WALKMAN" for the first time, or if you have not used your "WALKMAN" for a long time, it is best to charge until  (full charge) displays in the remaining battery indication.

Note

- If a large battery symbol is displayed while charging, the remaining charge is too low for your "WALKMAN" to operate. Charge continuously for about 10 minutes before attempting operations.

Related topic

[Turning on the power](#)

[Turning off the power](#)

[About battery life](#)

[Extending the battery life](#)

[Notes on charging the battery](#)

[▶ Troubleshooting](#)**How to Use**

What You Can Do

Parts Description

Setup

Enjoying Music

Enjoying Videos / Photos

Application

Android

Connections

Settings

Other Operations

Notifications

Announcements

Extending the battery life

You can reduce battery consumption by using your "WALKMAN" as follows.

- Adjust screen brightness. [\[Details\]](#)
- Set for a shorter time before the screen turns off. [\[Details\]](#)
- Turn off the screen when not using your "WALKMAN." [\[Details\]](#)
- Turn off the power when not using your "WALKMAN" for an extended period of time. [\[Details\]](#)
- Turn off Wi-Fi when not using that function. [\[Details\]](#)
- Turn off the Bluetooth function when not using that function. [\[Details\]](#)
- Turn off GPS when not using that function. [\[Details\]](#)

Related topic

[About battery life](#)



[▶ Troubleshooting](#)

How to Use

What You Can Do

Parts Description

Setup

Enjoying Music

Enjoying Videos / Photos

Application

Android

Connections

Settings

Other Operations

Notifications

Announcements

Notes on charging the battery

The following are notes regarding charging.

- Charging time differs depending on battery usage conditions.
- If the battery life is reduced to about half of its normal life even if sufficiently charged, it has probably worn out. Please contact your nearest Sony dealer.
- If you charge your "WALKMAN" when it has not been used for a long period of time, your computer may not recognize it, or nothing may appear on the display. Charge your "WALKMAN" for about 10 minutes, after which it should start operating normally again.
- Charge the battery in an ambient temperature of between 5 °C to 35 °C.
- The number of times the battery can be recharged from complete discharge is approximately 500 times. This number may vary depending on the conditions under which you use your "WALKMAN."
- Charge the battery at least once every six months to a year if you do not use your "WALKMAN" for a long period of time.
- Charging is not guaranteed with homebuilt or modified computers.
- Do not leave your "WALKMAN" connected for extended periods of time to a laptop computer that is not connected to AC power. Doing so may discharge the computer's battery.
- Do not turn on, restart, wake up from sleep mode, or shut down the computer with your "WALKMAN" connected to the computer by USB cable. Doing so may cause your "WALKMAN" to malfunction. Disconnect your "WALKMAN" from the computer before conducting those operations.
- Heat may build up in your "WALKMAN" while charging. This is not a malfunction.

Related topic

[Charging the battery](#)

[▶ Troubleshooting](#)

How to Use

What You Can Do

Parts Description

Setup

Enjoying Music

Enjoying Videos / Photos

Application

Android

Connections

Settings

Other Operations

Notifications

Announcements

Deleting a Google account

If you have registered multiple Google accounts, you can delete accounts other than the first one set by following the procedures below.

1. Tap the (Menu) button with the Home screen displayed, then tap [Settings] - [Accounts & sync].
2. Select to the account to delete from the list.
3. Tap [Remove account] - [Remove account].

Note



- The first Google account registered cannot be deleted by the procedures above. Initialize your "WALKMAN" to delete the account. [\[Details\]](#)

Related topic

[Setting a Google account](#)

[▶ Troubleshooting](#)**How to Use****What You Can Do****Parts Description****Setup****Enjoying Music****Enjoying Videos / Photos****Application****Android****Connections****Settings****Other Operations****Notifications****Announcements****Setting a Google account**

Set your Google account to use services provided by Google. Multiple accounts can be registered on your "WALKMAN."

1. Tap the  (Menu) button with the Home screen displayed, then tap [ Settings] - [ Accounts & sync] - [Add account] - [Google].
2. Follow the onscreen instructions to set the account.

Note

- Make sure your "WALKMAN" is connected to a Wi-Fi network when setting or logging in to your Google account.

Related topic[Deleting a Google account](#)



▶ Troubleshooting

How to Use

What You Can Do

Parts Description

Setup

Enjoying Music

Enjoying Videos / Photos

Application

Android

Connections

Settings

Other Operations

Notifications

Announcements

Replacing the headphone earbuds

To enjoy better sound quality, change the earbuds to another size or adjust the earbud position to fit your ears comfortably and snugly.

The M size earbuds are attached to the headphones before shipment. If you feel the M size earbuds do not suit your ears, replace them with the S or L size earbuds (supplied). Confirm the size of the earbuds by checking the color inside.

When you change the earbuds, turn them to install firmly on the headphones and prevent the earbud from detaching and remaining in your ear.

In addition to the supplied earbuds, SS size earbuds that are smaller than S size ones are also available (not supplied).

Earbud sizes (inside color)

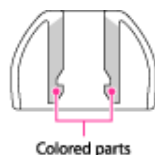

Small		Large
S (Orange)	M (Green)	L (Light blue)

To detach an earbud

While holding the headphone, twist and pull the earbud off.

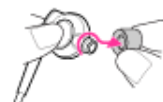

Hint

- If the earbud slips and cannot be detached, wrap it in a soft, dry cloth.

To attach an earbud

Twist and push the colored part of the earbud into the headphone until the projecting part of the headphone is fully covered.

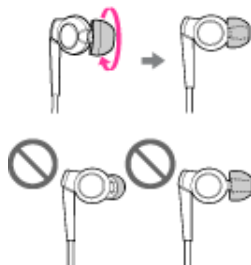

If the earbuds should become damaged, please purchase replacement earbuds (EP-EX10). Four types of earbuds are sold separately by size.

Related topic

[Contents](#)

[Caring for earbuds](#)

© 2012 Sony Corporation



▶ Troubleshooting

How to Use

What You Can Do

Parts Description

Setup

Enjoying Music

Enjoying Videos / Photos

Application

Android

Connections

Settings

Other Operations

Notifications

Announcements

Notes on the supplied software

The following are notes regarding use of the supplied software.

- Copyright laws prohibit reproducing the supplied software or the accompanying manuals, in whole or in part, or renting the software without the permission of the copyright holder.
- In no event will Sony be liable for any financial damage, loss of profits, or claims made by third parties arising out of the use of the supplied software.
- The supplied software cannot be used with equipment other than that for which it is so designated.
- Please note that, due to continued efforts to improve quality, specifications of the supplied software may be changed without notice.
- Operation of software other than that supplied is not guaranteed.
- The ability to display the languages on supplied software will depend on the installed OS on your computer. For better results, please ensure that the installed OS is compatible with the desired language you want to display.
 - We do not guarantee all the languages will be able to be displayed properly on the supplied software.
 - User-created characters and some special characters may not be displayed.
- If the data is initialized, all data (song, video, and photo data transferred to your “WALKMAN” as well as preinstalled sample data and software) will be erased. Be sure to verify the data stored in memory prior to initializing, and save necessary data to your computer.

[▶ Troubleshooting](#)**How to Use**

What You Can Do

Parts Description

Setup

Enjoying Music

Enjoying Videos / Photos

Application

Android

Connections

Settings

Other Operations

Notifications

Announcements

About Original apps

The Sony applications on your “WALKMAN” are displayed in a list, and they can be started by tapping. You can customize the icon layout as you like.

1. From the Home screen, tap [ Original apps].
-



▶ Troubleshooting

How to Use

What You Can Do

Parts Description

Setup

Enjoying Music

Enjoying Videos / Photos

Application

Android

Connections

Settings

Other Operations

Notifications

Announcements

Initializing

Delete data such as Google account information and downloaded applications, and reset your "WALKMAN" to factory default.

1. Tap the (Menu) button with the Home screen displayed, then tap [Settings] - [Privacy] - [Factory data reset] - [Reset device].
To delete music and photos transferred to your "WALKMAN," tap [Erase USB storage] and put a check in the checkbox.
2. Tap [Erase everything].
Your "WALKMAN" restarts automatically after being initialized.

Note

- If you put a check in the checkbox by tapping [Erase USB storage], the following data will be erased: Song and photo data transferred to your "WALKMAN"; Preinstalled content; Help guide for viewing on your "WALKMAN" screen; Setup.exe file stored on "WALKMAN" memory, for installation on your computer. Be careful because the data will not be offered again.

Related topic

[Resetting](#)

[▶ Troubleshooting](#)**How to Use**

What You Can Do

Parts Description

Setup

Enjoying Music

Enjoying Videos / Photos

Application

Android

Connections

Settings

Other Operations

Notifications

Announcements

Updating the system

Updating your "WALKMAN" to the latest version of the system software allows you to use the most recent functions in the optimal environment.

You will be notified of system updates by means such as the network.

Note

- It is best to back up data before updating your "WALKMAN."
-



▶ Troubleshooting

How to Use

What You Can Do

Parts Description

Setup

Enjoying Music

Enjoying Videos / Photos

Application

Android

Connections

Settings

Other Operations

Notifications

Announcements

Changing the settings

Various settings of your "WALKMAN" can be changed in the settings menu.

1. Tap the (Menu) button with the Home screen displayed, then tap [Settings].

2. Tap the menu item to set.

The menu items below can be set or confirmed:

- Wireless & networks
- Sound
- Display
- Location & security
- Applications
- Accounts & sync
- Privacy
- Storage
- Language & keyboard
- Voice input & output
- Accessibility
- Date & time
- About device



▶ Troubleshooting

How to Use

What You Can Do

Parts Description

Setup

Enjoying Music

Enjoying Videos / Photos

Application

Android

Connections

Settings



Other Operations

Notifications

Announcements

Changing the language settings

You can change the language used for screen display etc. on your "WALKMAN."

1. Tap the  (Menu) button with the Home screen displayed, then tap [ Settings] - [ Language & keyboard] - [Select language].
 2. Tap on the desired language.
-



▶ Troubleshooting

How to Use

What You Can Do

Parts Description

Setup

Enjoying Music

Enjoying Videos / Photos

Application

Android

Connections

Settings

Other Operations

Notifications

Announcements

How to use the touch screen

The display of your "WALKMAN" is a touch screen. Make operations by directly touching the screen. The basic operations are explained as follows.

Tap

Lightly touch an item such as an icon or menu with your finger and immediately remove your finger.

Tapping twice quickly is called "double tapping."

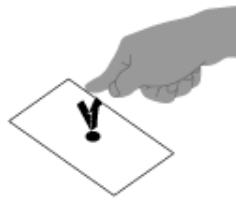

Press and Hold

Keep pressing an item such as an icon or menu.

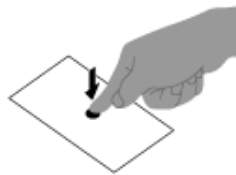

Flick

Lightly move your finger across the touch screen.

This switches screens or quickly scrolls through a page.

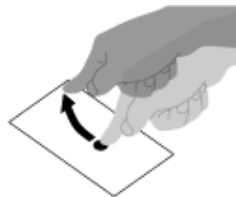

Drag

Keeping your finger on the touch panel, move to the desired point and release.

This moves icons, etc. and scrolls the screen.

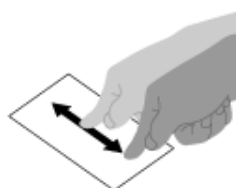



Pinch in/pinch out

Touch the screen with two fingers, and move the fingers apart (pinch out) or together (pinch in).

On some screens, pinching out zooms in and pinching in zooms out.



Hint

- You can zoom in and out on the displayed content by double tapping or by tapping the zoom control icons ( / ). Zoom control icons may be displayed when you drag the screen.

Related topic

[Home screen](#)

[Caring for the touch screen](#)

[Notes on the touch screen](#)



▶ Troubleshooting

How to Use

What You Can Do

Parts Description

Setup

Enjoying Music

Enjoying Videos / Photos

Application

Android

Connections

Settings

Other Operations

Notifications

Announcements

Notes on the touch screen

The following are notes regarding the touch screen and LCD screen.

Notes regarding the touch screen

- Your "WALKMAN" uses a capacitive touch screen. Tap the screen directly with your fingertip. Do not scratch it or tap it with sharp objects such as a needle, pen, or fingernail. You cannot operate the touch screen with a stylus.
- If you touch the touch screen with gloved fingers, it may operate incorrectly or may not operate at all.
- Do not operate your "WALKMAN" with objects on the touch screen.
- If the touch screen is touched by objects other than your fingertip, it may not react correctly.
- Do not put the touch screen close to other electrical devices. Electrostatic discharges can make the touch screen malfunction.
- If there are water droplets on the touch screen, or if you touch it with wet fingertips, the touch screen may not react correctly.
- Do not put the touch screen close to water. The touch screen may malfunction in humid conditions or when exposed to water.

Notes regarding the LCD screen

- Do not press hard on the LCD screen. Doing so may cause unevenness or damage.
- Do not leave the LCD screen in direct sunlight. Be sure to block direct sunlight when using your "WALKMAN" near a window.
- Using your "WALKMAN" in low temperature conditions may produce a residual image on the LCD screen. This does not indicate a malfunction. The screen will return to normal when your "WALKMAN" returns to normal temperature.
- A residual image may appear on the LCD screen if the same image is displayed for an extended period of time. The residual image will eventually disappear.
- The LCD screen becomes warm during operation. This is normal and does not indicate a malfunction.
- The LCD screen is manufactured using high-precision technology. You may, however, see tiny black points and/or bright points on the LCD screen. This is a normal result of the manufacturing process and does not indicate a malfunction.
- The LCD screen is made of glass. If the glass is damaged (cracked, etc.), do not touch the touch screen nor try to repair it by yourself. Handle the LCD screen carefully as it is vulnerable to dropping or mechanical shock. The warranty does not cover any damages caused by customers due to incorrect handling.

Related topic

[How to use the touch screen](#)

[Caring for the touch screen](#)

[▶ Troubleshooting](#)**How to Use**

What You Can Do

Parts Description

Setup

Enjoying Music

Enjoying Videos / Photos

Application

Android

Connections

Settings

Other Operations

Notifications

Announcements

Caring for the touch screen

The following explains care for the "WALKMAN" body and touch screen.

- Wipe with a soft cloth (eyeglasses cleaning cloth, etc.).
- If excessively dirty, wipe with a cloth moistened with diluted neutral detergent.
- Do not use chemicals such as thinner, benzine, or alcohol, as they may damage the surface finish.
- Be careful not to get water inside.

Related topic



[How to use the touch screen](#)

[Notes on the touch screen](#)

[▶ Troubleshooting](#)**How to Use****What You Can Do****Parts Description****Setup****Enjoying Music****Enjoying Videos / Photos****Application****Android****Connections****Settings****Other Operations****Notifications****Announcements****Limiting the volume [AVLS (Volume Limit)]**

You can set [AVLS (Volume Limit)] (Automatic Volume Limiter System) to limit the maximum volume to prevent auditory issues or distraction.

With [AVLS (Volume Limit)], you can reduce leaky noise by high volume, ear for feeling of oppression, and danger from blocking outside sounds.

1. Tap the  (Menu) button with the Home screen displayed, then tap [ Settings] - [ Sound] - [AVLS (Volume Limit)].

[▶ Troubleshooting](#)**How to Use**[What You Can Do](#)[Parts Description](#)[Setup](#)[Enjoying Music](#)[Enjoying Videos / Photos](#)[Application](#)[Android](#)[Connections](#)[Settings](#)[Other Operations](#)[Notifications](#)[Announcements](#)**Using the microphone**

The built-in microphone of your "WALKMAN" can be used to input sound.

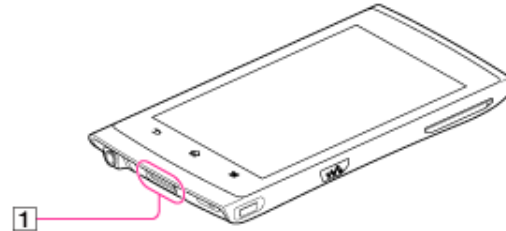

1 Built-in microphone

Do not cover the microphone when using it for functions such as voice recognition.

Note

- The microphone cannot be used when using FM radio. To use the microphone, stop FM radio. Do not use FM radio while using the microphone.

Related topic[Parts and controls](#)

[▶ Troubleshooting](#)**How to Use**[What You Can Do](#)[Parts Description](#)[Setup](#)[Enjoying Music](#)[Enjoying Videos / Photos](#)[Application](#)[Android](#)[Connections](#)[Settings](#)[Other Operations](#)[Notifications](#)[Announcements](#)**Using the speaker**

Sound can be played from the built-in speaker of your "WALKMAN."

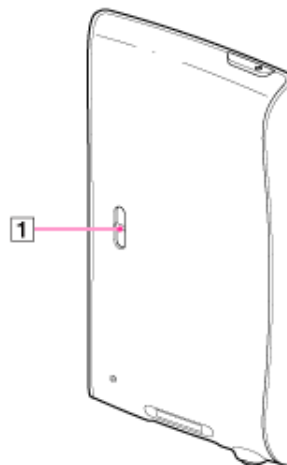

1 Speaker

Sound will be emitted from the speaker if headphones are not connected.

Note

- Sound will not be emitted from the speaker when using Bluetooth headphones or the HDMI jack.
- Sound may not be emitted from the speaker when accessories are connected to the WM-PORT jack.

Related topic[Parts and controls](#)[Adjusting the volume](#)

[▶ Troubleshooting](#)

How to Use

What You Can Do

Parts Description

Setup

Enjoying Music

Enjoying Videos / Photos

Application

Android

Connections

Settings

Other Operations

Notifications

Announcements

License and trademark notice

- “WALKMAN” and “WALKMAN” logo are registered trademarks of Sony Corporation.
- 12 TONE ANALYSIS and its logo are trademarks of Sony Corporation.
- Media Go is registered trademarks of Sony Electronics Inc.
- “LCMIR” and the “LCMIR” logo are trademarks of Sony Corporation.
- SensMe™ and the SensMe™ logo are trademarks or registered trademarks of Sony Ericsson Mobile Communications AB.
- “PlayStation” and “PSP” are registered trademarks of Sony Computer Entertainment Inc.
- Microsoft, Windows, Windows Vista and Windows Media are either trademarks or registered trademarks of Microsoft Corporation in the United States and/or other countries.
- IBM and PC/AT are registered trademarks of International Business Machines Corporation.
- Apple, Macintosh and iTunes are trademarks of Apple Inc., registered in the U.S. and other countries.
- Pentium is a trademark or a registered trademark of Intel Corporation.
- Wi-Fi, the Wi-Fi CERTIFIED logo, WPA, and WPA2 are trademarks or registered trademarks of Wi-Fi Alliance.
- The Bluetooth word mark and logos are owned by the Bluetooth SIG, Inc. and any use of such marks by Sony Corporation is under license. Other trademarks and trade names are those of their respective owners.



- DLNA is trademark or registered trademark of the Digital Living Network Alliance.
- HDMI, HDMI Logo and High-Definition Multimedia Interface, are trademarks or registered trademarks of HDMI Licensing LLC.
- Android, the stylized Android logo, Android Market, the stylized Android Market logo, Gmail, Google Calendar, Google Checkout, Google Latitude, Google Maps, Google Talk, Picasa, and YouTube are trademarks of Google Inc.
- Reader and the Reader logo are trademarks of Sony.
- “Sony Entertainment Network logo” and “Sony Entertainment Network” are trademarks of Sony Corporation.
- All other trademarks and registered trademarks are trademarks or registered trademarks of their respective holders. In this manual, TM and © marks are not specified.



▶ Troubleshooting

How to Use

What You Can Do

Parts Description

Setup

Enjoying Music

Enjoying Videos / Photos

Application

Android

Connections

Settings

Other Operations

Notifications

Announcements

Important product information

The following FCC statement applies only to the version of this model manufactured for sale in the USA. Other versions may not comply with FCC technical regulations.

NOTE:

This equipment has been tested and found to comply with the limits for a Class B digital device, pursuant to Part 15 of the FCC Rules. These limits are designed to provide reasonable protection against harmful interference in a residential installation. This equipment generates, uses and can radiate radio frequency energy and, if not installed and used in accordance with the instructions, may cause harmful interference to radio communications.

However, there is no guarantee that interference will not occur in a particular installation. If this equipment does cause harmful interference to radio or television reception, which can be determined by turning the equipment off and on, the user is encouraged to try to correct the interference by one or more of the following measures:

Reorient or relocate the receiving antenna.

Increase the separation between the equipment and receiver.

Connect the equipment into an outlet on a circuit different from that to which the receiver is connected.

Consult the dealer or an experienced radio/TV technician for help.

You are cautioned that any changes or modifications not expressly approved in this manual could void your authority to operate this equipment.

If you have any questions about this product:

Visit: www.sony.com/walkmansupport

Contact: Sony Customer Information Service Center at 1-(866)-456-7669

Write: Sony Customer Information Service Center 12451 Gateway Blvd., Fort Myers, FL 33913

Declaration of Conformity

Trade Name:

SONY

Model No.:

NWZ-Z1050

Responsible Party:

Sony Electronics Inc.

Address:.

16530 Via Esprillo, San Diego, CA 92127 U.S.A

Telephone Number:

858-942-2230

This device complies with Part 15 of the FCC Rules. Operation is subject to the following two conditions: (1) this device may not cause harmful interference, and (2) this device must accept any interference received, including interference that may cause undesired operation.

For users in France

At high volume, prolonged listening to the personal audio player can damage the user's hearing.



Notice for customers: the following information is only applicable to equipment sold in countries applying EU directives

The manufacturer of this product is Sony Corporation, 1-7-1 Konan Minato-ku Tokyo, 108-0075 Japan. The Authorized Representative for EMC and product safety is Sony Deutschland GmbH, Hedelfinger Strasse 61, 70327 Stuttgart, Germany. For any service or guarantee matters please refer to the addresses given in separate service or guarantee documents.

Disposal of Old Electrical & Electronic Equipment (Applicable in the European Union and other European countries with separate collection systems)



This symbol on the product or on its packaging indicates that this product shall not be treated as household waste. Instead it shall be handed over to the applicable collection point for the recycling of electrical and electronic equipment. By ensuring this product is disposed of correctly, you will help prevent potential negative consequences for the environment and human health, which could otherwise be caused by inappropriate waste handling of this product. The recycling of materials will help to conserve natural resources. For more detailed information about recycling of this product, please contact your local Civic Office, your household waste disposal service or the shop where you purchased the product.

Applicable accessories: Headphones

Disposal of waste batteries (applicable in the European Union and other European countries with separate collection systems)



This symbol on the battery or on the packaging indicates that the battery provided with this product shall not be treated as household waste.

On certain batteries this symbol might be used in combination with a chemical symbol. The chemical symbols for mercury (Hg) or lead (Pb) are added if the battery contains more than 0.0005% mercury or 0.004% lead.

By ensuring these batteries are disposed of correctly, you will help prevent potentially negative consequences for the environment and human health which could otherwise be caused by inappropriate waste handling of the battery. The recycling of the materials will help to conserve natural resources.

In case of products that for safety, performance or data integrity reasons require a permanent connection with an incorporated battery, this battery should be replaced by qualified service staff only.

To ensure that the battery will be treated properly, hand over the product at end-of-life to the applicable collection point for the recycling of electrical and electronic equipment.

For all other batteries, please view the section on how to remove the battery from the product safely. Hand the battery over to the applicable collection point for the recycling of waste batteries.

For more detailed information about recycling of this product or battery, please contact your local Civic Office, your household waste disposal service or the shop where you purchased the product.

This equipment must not be co-located or operated in conjunction with any other antenna or transmitter.

This device complies with Industry Canada licence-exempt RSS standard(s). Operation is subject to the following two conditions: (1) this device may not cause interference, and (2) this device must accept any interference, including interference that may cause undesired operation of the device.

Under Industry Canada regulations, this radio transmitter may only operate using an antenna of a type and maximum (or lesser) gain approved for the transmitter by Industry Canada. To reduce potential radio interference to other users, the antenna type and its gain should be so chosen that the equivalent isotropically radiated power (e.i.r.p.) is not more than that necessary for successful communication.

The following FCC/IC statement applies only to the version of this model manufactured for sale in the USA and Canada. Other versions may not comply with FCC/IC technical

regulations.

The available scientific evidence does not show that any health problems are associated with using low power wireless devices. There is no proof, however, that these low power wireless devices are absolutely safe. Low power Wireless devices emit low levels of radio frequency energy (RF) in the microwave range while being used. Whereas high levels of RF can produce health effects (by heating tissue), exposure of low-level RF that does not produce heating effects causes no known adverse health effects. Many studies of low-level RF exposures have not found any biological effects. Some studies have suggested that some biological effects might occur, but such findings have not been confirmed by additional research. These models have been tested and found to comply with FCC/IC radiation exposure limits set forth for an uncontrolled environment and meet the FCC radio frequency (RF) Exposure Guidelines in Supplement C to OET65 and RSS-102 of the IC radio frequency (RF) Exposure rules.

Listening for a Lifetime

Selecting fine audio equipment such as the unit you've just purchased is only the start of your musical enjoyment. Now it's time to consider how you can maximize the fun and excitement your equipment offers. This manufacturer, the Consumer Electronics Association (CEA)® and the American Speech-Language-Hearing Association (ASHA) want you to get the most out of your equipment by playing it at a safe level; a level that lets the sound come through clearly without annoying blaring or distortion and, most importantly, without damaging your sensitive hearing.

Sound can be deceiving. Over time your hearing "comfort level" adapts to higher volumes of sound. So what sounds "normal" can actually be loud and harmful to your hearing. Guard against this by setting your equipment at a safe level BEFORE your hearing adapts.

TO ESTABLISH A SAFE LEVEL:

- Set your volume control to the lowest level where you can hear the music comfortably and clearly. Prolonged exposure to anything over 85 decibels can cause gradual hearing loss.
- Once you have established a sound level where you can hear the audio comfortably, clearly and without distortion, set the dial and leave it there.
- See if your music player has a volume limiter that allows you to set a safe listening level by establishing a maximum volume level on your player. This is a great solution for parents to ensure their children listen at a safe level.
- Limit listening time to give your hearing "quiet breaks."

BE SURE TO OBSERVE THE FOLLOWING GUIDELINES WHEN WEARING YOUR HEADPHONES OR EARBUDS:

- Do not turn up the volume so high that you can't hear sounds around you.
- Do not use headphones or earbuds while operating a motorized vehicle; it may create a traffic hazard and is illegal in many areas.

Used wisely, your new sound equipment will provide years of fun and enjoyment. Since hearing damage from loud noise is often undetectable until it is too late, this manufacturer, CEA and ASHA recommend that you avoid prolonged exposure to excessive noise. The following list of sound levels is included for your information so that you can better protect your hearing.

DECIBEL LEVEL EXAMPLES:

30 Whisper
 40 Quiet room
 50 Moderate rainfall
 60 Normal conversation
 70 Busy traffic, vacuum cleaner
 80 Alarm clock

CONSTANT EXPOSURE TO THESE NOISES CAN BE DANGEROUS:

90 Lawn mower, motorcycle
 100 Chain saw
 110 Rock concert
 120 Jet plane takeoff
 130 Jackhammer
 140 Firecrackers

This information courtesy of the American Speech-Language-Hearing Association (ASHA),

the national professional, scientific and credentialing association for more than 135,000 audiologists, speech-language pathologists, and speech, language and hearing scientists.

For information on protection against noise-induced hearing loss, call the ASHA Action Center (800-638-8255), Monday through Friday, 8:30 a.m. to 5 p.m. To find an audiologist in your area, visit www.asha.org/findpro. Parents can find helpful information about how to protect their children's hearing and how to teach them about safe listening at www.listentoyourbuds.org, an ASHA award-winning public education campaign sponsored in part by CEA.

A safety tip from the Consumer Electronics Association, 1919 South Eads Street, Arlington, VA 22202 and the American Speech-Language-Hearing Association, 2200 Research Boulevard, Rockville, MD 20850.

Important information is also noted in the supplied "Quick Start Guide," etc.

[▶ Troubleshooting](#)**How to Use**

What You Can Do

Parts Description

Setup

Enjoying Music

Enjoying Videos / Photos

Application

Android

Connections

Settings

Other Operations

Notifications

Announcements

Caring for earbuds

Remove the earbuds from the headphones, and clean them by hand with dilute neutral detergent. Wipe off excess moisture before using the earbuds.

Related topic

[Replacing the headphone earbuds](#)

[▶ Troubleshooting](#)**How to Use**

What You Can Do

Parts Description

Setup

Enjoying Music

Enjoying Videos / Photos

Application

Android

Connections

Settings

Other Operations

Notifications

Announcements

Caring for headphone plugs

Dirty headphone plugs may cause noise or skipping. Occasionally wipe the ends of the headphone plugs with a soft, dry cloth to maintain good sound.

Related topic[Contents](#)

[▶ Troubleshooting](#)**How to Use**

What You Can Do

Parts Description

Setup

Enjoying Music

Enjoying Videos / Photos

Application

Android

Connections

Settings

Other Operations

Notifications

Announcements

Maximum recordable number of photo files (Approx.)

The following limitations apply for the number of photo files that can be recorded to your "WALKMAN."

Maximum recordable number of photo files

Max. 20,000 files

Max. 1,000 files/folder

Recordable number of photos may be less depending on file sizes.

Maximum number of photo files that can be thrown via DLNA

Max. 1,000 files

Related topic

[Maximum recordable number of songs and time \(Approx.\)](#)

[Maximum recordable time of videos \(Approx.\)](#)

[▶ Troubleshooting](#)

How to Use

[What You Can Do](#)[Parts Description](#)[Setup](#)[Enjoying Music](#)[Enjoying Videos / Photos](#)[Application](#)[Android](#)[Connections](#)[Settings](#)[Other Operations](#)[Notifications](#)[Announcements](#)

Maximum recordable number of songs and time (Approx.)

The approximate times are based on the case in which you transfer or record only 4 minute songs (not including videos and photos) in the MP3 format. Other playable audio file format song numbers and times may differ from MP3 format.

Maximum recordable number of songs

NWZ-Z1040 (8 GB)**48 kbps**

Approx. 3,300 songs

64 kbps

Approx. 2,500 songs

128 kbps

Approx. 1,250 songs

256 kbps

Approx. 600 songs

320 kbps

Approx. 500 songs

1,411 kbps (Linear PCM)

Approx. 100 songs

NWZ-Z1050 (16 GB)**48 kbps**

Approx. 8,750 songs

64 kbps

Approx. 6,550 songs

128 kbps

Approx. 3,250 songs

256 kbps

Approx. 1,600 songs

320 kbps

Approx. 1,300 songs

1,411 kbps (Linear PCM)

Approx. 295 songs

NWZ-Z1060 (32 GB)**48 kbps**

Approx. 19,500 songs

64 kbps

Approx. 14,500 songs

128 kbps

Approx. 7,350 songs

256 kbps

Approx. 3,650 songs

320 kbps

Approx. 2,950 songs

1,411 kbps (Linear PCM)

Approx. 670 songs

Maximum recordable time of songs

NWZ-Z1040 (8 GB)**48 kbps**

Approx. 220 hr. 00 min.

64 kbps

Approx. 166 hr. 40 min.

128 kbps

Approx. 83 hr. 20 min.

256 kbps

Approx. 40 hr. 00 min.

320 kbps

Approx. 33 hr. 20 min.

1,411 kbps (Linear PCM)

Approx. 6 hr. 40 min.

NWZ-Z1050 (16 GB)

48 kbps

Approx. 583 hr. 20 min.

64 kbps

Approx. 436 hr. 40 min.

128 kbps

Approx. 216 hr. 40 min.

256 kbps

Approx. 106 hr. 40 min.

320 kbps

Approx. 86 hr. 40 min.

1,411 kbps (Linear PCM)

Approx. 19 hr. 40 min.

NWZ-Z1060 (32 GB)

48 kbps

Approx. 1,300 hr. 00 min.

64 kbps

Approx. 966 hr. 40 min.

128 kbps

Approx. 490 hr. 00 min.

256 kbps

Approx. 243 hr. 20 min.

320 kbps

Approx. 196 hr. 40 min.

1,411 kbps (Linear PCM)

Approx. 44 hr. 40 min.

Maximum recordable number of playlists

Maximum transferrable number of playlists:

8,192

Maximum containable number of songs in each playlist:

999

Note

- The approximate times are based on the case in which you transfer or record only 4 minute songs (not including videos and photos) in the MP3 format. Other playable audio file format song numbers and times may differ from MP3 format.

Related topic

[Maximum recordable time of videos \(Approx.\)](#)

[Maximum recordable number of photo files \(Approx.\)](#)

[▶ Troubleshooting](#)

How to Use

What You Can Do

Parts Description

Setup

Enjoying Music

Enjoying Videos / Photos

Application

Android

Connections

Settings

Other Operations

Notifications

Announcements

Maximum recordable time of videos (Approx.)

The approximate times are estimated in the case where only videos are transferred. The time may differ, depending on the conditions under which the player is used.

Maximum recordable time

NWZ-Z1040 (8 GB)

Video Format: 384 kbps/Music Format: 128 kbps

Approx. 20 hr. 50 min.

Video Format: 768 kbps/Music Format: 128 kbps

Approx. 11 hr. 50 min.

NWZ-Z1050 (16 GB)

Video Format: 384 kbps/Music Format: 128 kbps

Approx. 54 hr. 50 min.

Video Format: 768 kbps/Music Format: 128 kbps

Approx. 31 hr. 20 min.

NWZ-Z1060 (32 GB)

Video Format: 384 kbps/Music Format: 128 kbps

Approx. 123 hr. 10 min.

Video Format: 768 kbps/Music Format: 128 kbps

Approx. 70 hr. 20 min.

File size

Max. 4 GB

Related topic

[Maximum recordable number of songs and time \(Approx.\)](#)

[Maximum recordable number of photo files \(Approx.\)](#)

[▶ Troubleshooting](#)**How to Use**

What You Can Do

Parts Description

Setup

Enjoying Music

Enjoying Videos / Photos

Application

Android

Connections

Settings

Other Operations

Notifications

Announcements

Contents

Before using, make sure that none of the supplied items is missing or damaged.

- "WALKMAN" (1)
- Headphones (1)
- Earbuds (Size S, M, L)
- USB cable (1)
- Quick Start Guide
- Software

The software is stored in the built-in flash memory of the player, and includes the following items. For details on how to install, refer to "Quick Start Guide."

- Media Go
- WALKMAN Guide
Help guide, etc.

Related topic

[Parts and controls](#)

[Replacing the headphone earbuds](#)



▶ Troubleshooting

How to Use

What You Can Do

Parts Description

Setup

Enjoying Music

Enjoying Videos / Photos

Application

Android

Connections

Settings

Other Operations

Notifications

Announcements

Specifications

Specifications of your "WALKMAN" are as follows.

Platform

Android™ Version 2.3

Display

4.3-inch (10.9 cm), TFT color display with white LED-backlight, WQVGA (800 × 480 Pixels)

Interface

USB:

Hi-Speed USB (USB 2.0 compliant)

Headphone:

Stereo mini-jack

WM-PORT:

WM-PORT (multiple connecting terminal): 22 pins

HDMI:

HDMI micro

FM radio

FM Frequency range:

87.5 MHz to 108.0 MHz

Antenna:

Headphone cord antenna

Wireless LAN

IEEE 802.11b/g/n

Bluetooth

Communication system: Bluetooth specification version 2.1+EDR (*1)

Sensor

GPS receiver

Accelerometer

Magnetmeter

Speaker

Monaural

Microphone

Monaural

Output (headphones)

Frequency response

20 Hz to 20,000 Hz (when playing data file, single signal measurement)

Sound Effects

S-Master MX

DSEE (Sound enhance) (On/Off)

5 Band equalizer (None/Heavy/Pop/Jazz/Unique/Custom 1/Custom 2) & Clear Bass

VPT (Surround) (None/Studio/Live/Club/Arena/Matrix)

Clear stereo (On/Off)

Clear Phase™ (On/Off)

Dynamic normalizer (On/Off)

Power Source

Built-in Rechargeable lithium-ion Battery

USB power (from a computer via a USB connector of the player)

Charging Time

USB-based charging

Approx. 5 hours

Operating temperature

5 °C to 35 °C (41 °F to 95 °F)

Dimensions

w/h/d, projecting parts not included

70.5 mm × 134.2 mm × 11.1 mm (2 7/8 inches × 5 3/8 inches × 7/16 inches)

w/h/d

70.9 mm × 134.4 mm × 11.1 mm (2 7/8 inches × 5 3/8 inches × 7/16 inches)

Mass

156 g (5.6 oz)

Capacity (User available capacity) (*2)

Actual available memory for other contents (*2):

NWZ-Z1040: approx. 4.58 GB=4,918,640,640 bytes

NWZ-Z1050: approx. 12.0 GB=12,940,410,880 bytes

NWZ-Z1060: approx. 27.0 GB=29,088,710,656 bytes

Actual available memory for application software (*3):

NWZ-Z1040: approx. 0.98 GB=1,056,858,112 bytes

NWZ-Z1050: approx. 0.98 GB=1,056,858,112 bytes

NWZ-Z1060: approx. 0.98 GB=1,056,858,112 bytes

Maximum recordable number of song and video files (Approx.)

40,500

(*1) EDR stands for Enhanced Data Rate.

(*2) Available capacity may vary. A portion of the memory is used for data management functions.

(*3) Actual available memory for application software includes the memory space which is used for factory-preinstalled applications.

“WALKMAN” specifications and designs are subject to change without notice.

Related topic

[Maximum recordable number of songs and time \(Approx.\)](#)

[Maximum recordable time of videos \(Approx.\)](#)

[Maximum recordable number of photo files \(Approx.\)](#)

[System requirements](#)

[Supported formats](#)

[▶ Troubleshooting](#)[How to Use](#)[What You Can Do](#)[Parts Description](#)[Setup](#)[Enjoying Music](#)[Enjoying Videos / Photos](#)[Application](#)[Android](#)[Connections](#)[Settings](#)[Other Operations](#)[Notifications](#)[Announcements](#)

Supported formats

The following file formats are supported by your "WALKMAN."

Music (Music player)

Audio Formats (Codec)

MP3

Media File format: MP3 (MPEG-1 Layer3) file format

File extension: .mp3

Bit rate: 32 to 320 kbps (Supports variable bit rate (VBR))

Sampling frequency (*2): 32, 44.1, 48 kHz

WMA (*1)

Media File format: ASF file format

File extension: .wma

Bit rate: 32 to 192 kbps (Supports variable bit rate (VBR))

Sampling frequency (*2): 44.1 kHz

AAC (*3)

Media File format: MP4 file format

File extension: .mp4, .m4a, .3gp

Bit rate: 16 to 320 kbps (Supports variable bit rate (VBR)) (*4)

Sampling frequency (*2): 8, 11.025, 12, 16, 22.05, 24, 32, 44.1, 48 kHz

Linear PCM

Media File format: Wave-Riff file format

File extension: .wav

Bit rate: 1,411 kbps

Sampling frequency (*2): 44.1 kHz

HE-AAC

Media File format: MP4 file format

File extension: .mp4, .m4a, .3gp

Bit rate: 32 to 144 kbps

Sampling frequency (*1) : 8, 11.025, 12, 16, 22.05, 24, 32, 44.1, 48 kHz

Video

Video Formats (Codec)

AVC (H.264/AVC)

Media File format: MP4 file format, "Memory Stick" video format

File extension: .mp4, .m4v

Profile: Baseline Profile

Level: 3.1

Bit rate: Max. 18 Mbps

Frame rate: Max. 30 fps

Resolution: Max. 1,920 × 1,080 (*5)

Media File format: MP4 file format, "Memory Stick" video format

File extension: .mp4, .m4v

Profile: Main Profile

Level: 3

Bit rate: Max. 2 Mbps

Frame rate: Max. 30 fps

Resolution: Max. 720 × 480 (*5)

MPEG-4

Media File format: MP4 file format, "Memory Stick" video format

File extension: .mp4, .m4v

Profile: Simple Profile/Advanced Simple Profile

Bit rate: Max. 10 Mbps
Frame rate: Max. 30 fps
Resolution: Max. 1,920 × 1,080 (*5)

Windows Media

Video 9 (*1) (*6)

Media File format: ASF file format
File extension: .wmv
Bit rate: Max. 20 Mbps
Frame rate: Max. 30 fps
Resolution: Max. 1,920 × 1,080 (*5)

Audio Formats (Codec)

AAC-LC (for AVC, MPEG-4)

Channel number: Max. 2 channels
Sampling frequency (*2): 24, 32, 44.1, 48 kHz
Bit rate: Max. 288 kbps/channel

WMA (for Windows Media Video 9)

Bit rate: 32 to 192 kbps (Supports variable bit rate (VBR))
Sampling frequency (*2): 44.1 kHz

Photo (*7) (Photo Viewer)

Photo Format (Codec)

JPEG

Media File format: Compatible with DCF 2.0/Exif 2.21 file format
File extension: .jpg, .jpeg
Profile: Baseline Profile
Number of pixels: Max. 6,048 × 4,032 pixels (24,000,000 pixels)

(*1) Copyright protected WMA/WMV files cannot be played back.

(*2) Sampling frequency may not correspond to all encoders.

(*3) Copyright protected AAC-LC files cannot be played back.

(*4) Non-standard bit rates or non-guaranteed bit rates are included depending on the sampling frequency.

(*5) These numbers indicate the maximum resolution of playable video, and do not indicate the player's display resolution. The display resolution is 800 × 480.

(*6) Some WMV files can be played back only by transferring using Windows Media Player

(*7) Some photo files cannot be played back, depending on their file formats.



▶ Troubleshooting

How to Use

What You Can Do

Parts Description

Setup

Enjoying Music

Enjoying Videos / Photos

Application

Android

Connections





Settings

Other Operations

Notifications

Announcements

Notation in explanations of operations

In this Help guide, the buttons on the “WALKMAN” are shown as illustrations such as  (Back) button,  (Home) button, and  (Menu) button. Items such as screen icons and menus are noted as [ Apps], [Bluetooth], etc.

Home screen

The Home screen is displayed by tapping the  (Home) button.

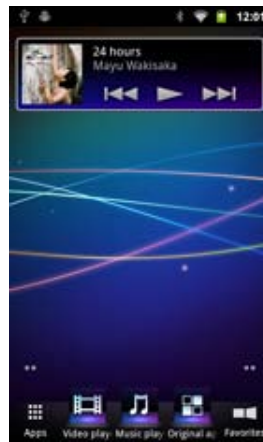

Note

- Explanations of operations are made assuming that you will start from the Home screen. In cases such as when a different application is used, operation procedures may differ from the explanation.
- The screens and illustrations herein are for descriptive purposes, and they may differ from the actual product or screen.
- If there are multiple ways to use a function or make a setting, the method that is easiest to understand is described.

Related topic

[Parts and controls](#)

[▶ Troubleshooting](#)**How to Use****What You Can Do****Parts Description****Setup****Enjoying Music****Enjoying Videos / Photos****Application****Android****Connections****Settings****Other Operations****Notifications****Announcements****Sample data**

This product is preinstalled with music, video, and photo sample data.

Once deleted, the sample data cannot be restored. Please note that Sony will not provide replacement sample data.

- Copyright law prohibits use of content you have recorded for purposes other than your personal enjoyment without permission from the copyright holder.
- Please note that you will not be compensated for inability to record or download or if your music, video, or photo data is damaged or deleted due to problems with this product or the computer.
- Some text and symbols may not be displayed properly on this product for the following reasons.
 - Capabilities of the player connected to the computer are insufficient.
 - Languages or characters not supported by the player are used in content and file data.

[▶ Troubleshooting](#)**How to Use**

What You Can Do

Parts Description

Setup

Enjoying Music

Enjoying Videos / Photos

Application

Android

Connections

Settings

Other Operations

Notifications

Announcements

Customer support websites

If you have any questions or issues with this product, or would like information on compatible items with this product, visit the following websites.

For customer in the USA:

<http://www.sony.com/walkmansupport>

For customers in Canada:

<http://www.sony.ca/ElectronicsSupport/>

For customers in Europe:

<http://support.sony-europe.com/DNA>

For customers in Latin America:

<http://www.sony-latin.com/index.crp>

For customers in other countries/regions:

<http://www.sony-asia.com/support>

For customers who purchased the overseas models:

<http://www.sony.co.jp/overseas/support/>



▶ Troubleshooting

How to Use

What You Can Do

Parts Description

Setup

Enjoying Music

Enjoying Videos / Photos

Application

Android

Connections

Settings

Other Operations

Notifications

Announcements

System requirements

We do not guarantee operation for all computers even if they meet the following system requirements.

- Computer
 - IBM PC/AT compatible computer preinstalled with the following Windows operating systems (*1):
 - Windows® XP Home Edition (*2) (Service Pack 3 or later)
 - Windows® XP Professional (*2) (Service Pack 3 or later)
 - Windows Vista® Home Basic (Service Pack 2 or later)
 - Windows Vista® Home Premium (Service Pack 2 or later)
 - Windows Vista® Business (Service Pack 2 or later)
 - Windows Vista® Ultimate (Service Pack 2 or later)
 - Windows® 7 Starter (Service Pack 1 or later)
 - Windows® 7 Home Basic (Service Pack 1 or later)
 - Windows® 7 Home Premium (Service Pack 1 or later)
 - Windows® 7 Professional (Service Pack 1 or later)
 - Windows® 7 Ultimate (Service Pack 1 or later)

Not supported by OSs other than above

[Compatibility mode] for Windows® XP (included with Windows Vista® and Windows® 7) is not supported.

(*1) Excluding OS Versions not supported by Microsoft.

(*2) Excluding 64-bit OS versions.

- CPU
 - CPU: 1 GHz processor (2.6 GHz recommended for video playback)
- RAM
 - RAM: 1 GB or more
- Hard Disk Drive
 - Hard Disk Drive: 600 MB or more of available space
- Sound board
 - Sound card
- USB connector
 - USB port (Hi-Speed USB is recommended)
- Web Browser
 - Internet Explorer 7 or later
- Internet
 - Broadband Internet connection is required to use Gracenote® MusicID® service or podcast, or to visit the web store site.
- Guarantee operation
 - We do not guarantee operation for all computers even if they meet the above System Requirements.
 - Not supported by the following environments:
 - Personally constructed computers or operating systems
 - An environment that is an upgrade of the original manufacturer-installed operating system
 - Multi-boot environment
 - Multi-monitor environment
 - Macintosh

Design and specifications are subject to change without notice.

[▶ How to Use](#)

Troubleshooting

General**Music****Video / Photo****Apps****Supplied Software****Bluetooth**

A Bluetooth connection cannot be established.

Noise is generated when a Bluetooth connection is made.

Sound skips during music playback when a Bluetooth connection is made.

The screen to enter the passkey appears when a Bluetooth connection is made.

The sound distorts or breaks when a Bluetooth connection is made.

The sound tends to break when a Bluetooth connection is made.

Video sound is delayed when a Bluetooth connection is made.

Volume cannot be changed when a Bluetooth connection is made.

You cannot hear the sound even if a Bluetooth connection has been made.

You cannot register a Bluetooth device (cannot complete pairing).

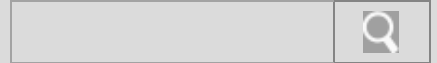

[▶ How to Use](#)

Troubleshooting

General

Music

Video / Photo

Apps

Supplied Software

Connection

A Bluetooth connection cannot be established.

The screen to enter the passkey appears when a Bluetooth connection is made.

You cannot register a Bluetooth device (cannot complete pairing).

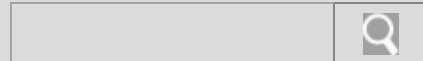

[▶ How to Use](#)

Troubleshooting

General

Music

Video / Photo

Apps

Supplied Software

Deletion

Songs transferred from your computer cannot be deleted on your "WALKMAN."



[▶ How to Use](#)

Troubleshooting

General

Music

Video / Photo

Apps

Supplied Software

FM radio

FM broadcasts are unclear.

FM broadcasts cannot be heard.

Noise is generated with FM broadcasts.

There is lots of noise with FM broadcasts, and sound quality is poor.



[▶ How to Use](#)

Troubleshooting

General

Music

Video / Photo

Apps

Supplied Software

Operation

The date and time have been reset.

The touch screen does not operate properly.

Your "WALKMAN" does not operate (does not respond to button operations).

Your "WALKMAN" does not work properly.

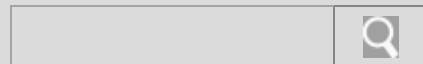

[▶ How to Use](#)

Troubleshooting

General

Music

Video / Photo

Apps

Supplied Software

Power

[Battery life is short.](#)

[▶ How to Use](#)

Troubleshooting

General**Music****Video / Photo****Apps****Supplied Software****Transfer**

The computer does not recognize your "WALKMAN" even if connected by USB cable.

Your "WALKMAN" becomes unstable while it is connected to the computer.

You might be looking for the following topics:

[Data cannot be transferred.](#)

[Only a small amount of data can be transferred to your "WALKMAN."](#)

[The transfer takes too much time.](#)

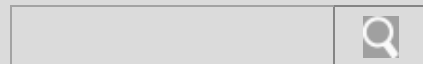

[▶ How to Use](#)

Troubleshooting

General

Music

Video / Photo

Apps

Supplied Software

Charging

Charging completes very quickly.

Your "WALKMAN" cannot charge the battery.

[▶ How to Use](#)**Troubleshooting****General****Music****Video / Photo****Apps****Supplied Software****DLNA**

Content on the DLNA server cannot be played.

You cannot return to the screen for controlling playback on other devices.

You cannot send (Throw) content to another device (playback device) and play it back.

[▶ How to Use](#)

Troubleshooting

General**Music****Video / Photo****Apps****Supplied Software****Display**

Cover art is not displayed.

Songs that are displayed when [All songs] or [Albums] is selected are not displayed when [Folders] is selected.

Songs/videos cannot be played, or photos cannot be displayed.

The screen turns off.

Videos and photos transferred from a computer are not displayed in a list.

[Unknown] is displayed for an album name, artist name, etc.



[▶ How to Use](#)

Troubleshooting

General

Music

Video / Photo

Apps

Supplied Software

General

Your "WALKMAN" gets warm.

You might be looking for the following topics:

[Help guide or an application does not operate.](#)

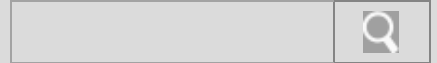

[▶ How to Use](#)

Troubleshooting

General

Music

Video / Photo

Apps

Supplied Software

Playback

Playback does not stop.

Playback has stopped suddenly.

Songs/videos cannot be played, or photos cannot be displayed.

There is no sound from the right channel of the headphones. Or the right channel sound is heard from both sides of the headphones.

Volume cannot be turned up.

[▶ How to Use](#)

Troubleshooting

General**Music****Video / Photo****Apps****Supplied Software****Sound**

Noise can be heard when plugging in or unplugging the headphones.

Noise is generated when a Bluetooth connection is made.

Noise is generated.

Playback has stopped suddenly.

Sound skips during music playback when a Bluetooth connection is made.

The sound distorts or breaks when a Bluetooth connection is made.

The sound tends to break when a Bluetooth connection is made.

There is no sound from the right channel of the headphones. Or the right channel sound is heard from both sides of the headphones.

There is no sound.

Video sound is delayed when a Bluetooth connection is made.

Volume cannot be changed when a Bluetooth connection is made.

Volume cannot be turned up.

You cannot hear the sound even if a Bluetooth connection has been made.

[Clear stereo] function is not effective.

[VPT (Surround)] function is not effective.

[▶ How to Use](#)

Troubleshooting

General**Music****Video / Photo****Apps****Supplied Software****USB connection**

The computer does not recognize your "WALKMAN" even if connected by USB cable.

Your "WALKMAN" becomes unstable while it is connected to the computer.

Your "WALKMAN" is not recognized as USB storage.

You might be looking for the following topics:

[Data cannot be transferred.](#)

[Only a small amount of data can be transferred to your "WALKMAN."](#)

[The transfer takes too much time.](#)

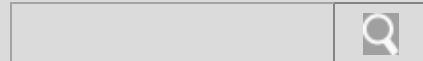

[▶ How to Use](#)

Troubleshooting

General

Music

Video / Photo

Apps

Supplied Software

Deletion

[Songs transferred from your computer cannot be deleted on your "WALKMAN."](#)

[▶ How to Use](#)**Troubleshooting**

General**Music****Video / Photo**

Apps

Supplied Software

Playback

[Playback does not stop.](#)

[Playback has stopped suddenly.](#)

[There is no sound from the right channel of the headphones. Or the right channel sound is heard from both sides of the headphones.](#)

[Volume cannot be turned up.](#)

You might be looking for the following topics:

[Songs/videos cannot be played, or photos cannot be displayed.](#)

[▶ How to Use](#)**Troubleshooting**

General**Music****Video / Photo**

Apps

Supplied Software

Transfer

Data cannot be transferred.

Only a small amount of data can be transferred to your "WALKMAN."

The computer does not recognize your "WALKMAN" even if connected by USB cable.

The transfer takes too much time.

You might be looking for the following topics:

Your "WALKMAN" becomes unstable while it is connected to the computer.

[▶ How to Use](#)**Troubleshooting**

General**Music****Video / Photo**

Apps

Supplied Software

Display

Cover art is not displayed.

Songs that are displayed when [All songs] or [Albums] is selected are not displayed when [Folders] is selected.

[Unknown] is displayed for an album name, artist name, etc.

You might be looking for the following topics:

Songs/videos cannot be played, or photos cannot be displayed.

The screen turns off.

Videos and photos transferred from a computer are not displayed in a list.

[▶ How to Use](#)**Troubleshooting**

General**Music****Video / Photo**

Apps

Supplied Software

Sound

Playback has stopped suddenly.

There is no sound from the right channel of the headphones. Or the right channel sound is heard from both sides of the headphones.

There is no sound.

Volume cannot be turned up.

You might be looking for the following topics:

Noise can be heard when plugging in or unplugging the headphones.

Noise is generated when a Bluetooth connection is made.

Noise is generated.

Sound skips during music playback when a Bluetooth connection is made.

The sound distorts or breaks when a Bluetooth connection is made.

The sound tends to break when a Bluetooth connection is made.

Video sound is delayed when a Bluetooth connection is made.

Volume cannot be changed when a Bluetooth connection is made.

You cannot hear the sound even if a Bluetooth connection has been made.

[Clear stereo] function is not effective.

[VPT (Surround)] function is not effective.

[▶ How to Use](#)**Troubleshooting**

General**Music****Video / Photo**

Apps

Supplied Software

USB connection

Data cannot be transferred.

Only a small amount of data can be transferred to your "WALKMAN."

The computer does not recognize your "WALKMAN" even if connected by USB cable.

The transfer takes too much time.

You might be looking for the following topics:

Your "WALKMAN" becomes unstable while it is connected to the computer.

Your "WALKMAN" is not recognized as USB storage.

[▶ How to Use](#)**Troubleshooting**

General

Music**Video / Photo****Apps**

Supplied Software

Display

Songs/videos cannot be played, or photos cannot be displayed.

Videos and photos transferred from a computer are not displayed in a list.

You might be looking for the following topics:

Cover art is not displayed.

Songs that are displayed when [All songs] or [Albums] is selected are not displayed when [Folders] is selected.

The screen turns off.

[Unknown] is displayed for an album name, artist name, etc.

[▶ How to Use](#)**Troubleshooting**

General

Music

Video / Photo

Apps

Supplied Software

Sound

Playback has stopped suddenly.

There is no sound from the right channel of the headphones. Or the right channel sound is heard from both sides of the headphones.

There is no sound.

Volume cannot be turned up.

You might be looking for the following topics:

Noise can be heard when plugging in or unplugging the headphones.

Noise is generated when a Bluetooth connection is made.

Noise is generated.

Sound skips during music playback when a Bluetooth connection is made.

The sound distorts or breaks when a Bluetooth connection is made.

The sound tends to break when a Bluetooth connection is made.

Video sound is delayed when a Bluetooth connection is made.

Volume cannot be changed when a Bluetooth connection is made.

You cannot hear the sound even if a Bluetooth connection has been made.

[Clear stereo] function is not effective.

[VPT (Surround)] function is not effective.

[▶ How to Use](#)**Troubleshooting**

General

Music

Video / Photo

Apps

Supplied Software

USB connection

Data cannot be transferred.

Only a small amount of data can be transferred to your "WALKMAN."

The computer does not recognize your "WALKMAN" even if connected by USB cable.

The transfer takes too much time.

You might be looking for the following topics:

Your "WALKMAN" becomes unstable while it is connected to the computer.

Your "WALKMAN" is not recognized as USB storage.

[▶ How to Use](#)**Troubleshooting**

General

Music**Video / Photo****Apps**

Supplied Software

Playback

[Playback does not stop.](#)

[Playback has stopped suddenly.](#)

[Songs/videos cannot be played, or photos cannot be displayed.](#)

[There is no sound from the right channel of the headphones. Or the right channel sound is heard from both sides of the headphones.](#)

[Volume cannot be turned up.](#)

[▶ How to Use](#)**Troubleshooting**

General

Music**Video / Photo****Apps**

Supplied Software

Transfer

Data cannot be transferred.

Only a small amount of data can be transferred to your "WALKMAN."

The computer does not recognize your "WALKMAN" even if connected by USB cable.

The transfer takes too much time.

You might be looking for the following topics:

Your "WALKMAN" becomes unstable while it is connected to the computer.

[▶ How to Use](#)**Troubleshooting**

General

Music

Video / Photo

Apps

Supplied Software

DLNA

Content on the DLNA server cannot be played.

You cannot return to the screen for controlling playback on other devices.

You cannot send (Throw) content to another device (playback device) and play it back.



[▶ How to Use](#)

Troubleshooting

General

Music

Video / Photo

Apps

Supplied Software

General

[Help guide or an application does not operate.](#)

You might be looking for the following topics:

[Your "WALKMAN" gets warm.](#)



[▶ How to Use](#)

Troubleshooting

General

Music

Video / Photo

Apps

Supplied Software

FM radio

FM broadcasts are unclear.

FM broadcasts cannot be heard.

Noise is generated with FM broadcasts.

There is lots of noise with FM broadcasts, and sound quality is poor.



[▶ How to Use](#)

Troubleshooting

General

Music

Video / Photo

Apps

Supplied Software

Help guide

[Help guide or an application does not operate.](#)

[▶ How to Use](#)**Troubleshooting**

General

Music

Video / Photo

Apps**Supplied Software****Installation**

Software cannot be installed on the computer.

The progress bar on the install screen does not proceed while installing software. Or, the access lamp of the hard drive does not light for several minutes.

[▶ How to Use](#)**Troubleshooting**

General

Music

Video / Photo

Apps**Supplied Software****USB connection**

Data cannot be transferred.

Only a small amount of data can be transferred to your "WALKMAN."

The transfer takes too much time.

You might be looking for the following topics:

The computer does not recognize your "WALKMAN" even if connected by USB cable.

Your "WALKMAN" becomes unstable while it is connected to the computer.

Your "WALKMAN" is not recognized as USB storage.

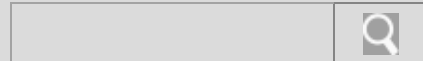

[▶ How to Use](#)

Troubleshooting

General

Music

Video / Photo

Apps

Supplied Software

Transfer

Data cannot be transferred.

Only a small amount of data can be transferred to your "WALKMAN."

The transfer takes too much time.

You might be looking for the following topics:

The computer does not recognize your "WALKMAN" even if connected by USB cable.

Your "WALKMAN" becomes unstable while it is connected to the computer.

[▶ How to Use](#)**Troubleshooting****General****Music****Video / Photo****Apps****Supplied Software****A Bluetooth connection cannot be established.**

The Bluetooth device to connect with is not turned on.

- Turn on the Bluetooth device, and make sure the Bluetooth function is activated.

Registering (pairing) the Bluetooth device failed or was not completed.

- Your "WALKMAN" cannot connect with devices that are not registered (paired). Register (pair) the Bluetooth device(s). [\[Details\]](#)

Your "WALKMAN" or the Bluetooth device to connect with was in sleep mode.

- Exit from sleep mode.

The remaining battery power is low or depleted.

- Charge the battery by means such as connecting your "WALKMAN" to a running computer. [\[Details\]](#)

The registration (pairing) information on your "WALKMAN" or the Bluetooth device to connect with has been deleted as a result of initializing settings, formatting memory, etc.

- Register (pair) your "WALKMAN" and the Bluetooth device to connect with again. [\[Details\]](#)

The Bluetooth audio device profile does not support A2DP.

- Make sure the Bluetooth audio device profile supports A2DP.



[▶ How to Use](#)

Troubleshooting

General

Music

Video / Photo

Apps

Supplied Software

Noise is generated when a Bluetooth connection is made.

The Bluetooth connection may be broken.

- End the Bluetooth connection and reestablish it.

You may hear noise in certain usage environments.

- Change the location, end the Bluetooth connection, and reestablish it.

You may hear noise from only one side of the headphones, depending on the connection status.

- End the Bluetooth connection and reestablish it.
-



[▶ How to Use](#)

Troubleshooting

General

Music

Video / Photo

Apps

Supplied Software

Sound skips during music playback when a Bluetooth connection is made.

Sound may skip depending on the usage environment or settings.

- o Place your "WALKMAN" and the Bluetooth device closer together. That may reduce skipping.
-



[▶ How to Use](#)

Troubleshooting

General

Music

Video / Photo

Apps

Supplied Software

The screen to enter the passkey appears when a Bluetooth connection is made.

A passkey may need to be entered when establishing a connection with certain Bluetooth devices.

- Enter the same passkey on your "WALKMAN" and the Bluetooth device. [\[Details\]](#) See the manual for your Bluetooth device for instructions on how to enter the passkey on the Bluetooth device.
-



[▶ How to Use](#)

Troubleshooting

General

Music

Video / Photo

Apps

Supplied Software

The sound distorts or breaks when a Bluetooth connection is made.

A transceiver, wireless LAN device, or another Bluetooth device using the 2.4 GHz frequency or a microwave oven or other device that is emitting electromagnetic waves is in use near your "WALKMAN" or the connected Bluetooth device.

- Use your "WALKMAN" or the connected Bluetooth device away from the above devices.

Obstacles (metal, people, walls, etc.) are between your "WALKMAN" and the connected Bluetooth device.

- Avoid or remove any obstacles between your "WALKMAN" and the connected Bluetooth device.
-

[▶ How to Use](#)**Troubleshooting**

General

Music

Video / Photo

Apps

Supplied Software

The sound tends to break when a Bluetooth connection is made.

A transceiver, wireless LAN device, or another Bluetooth device using the 2.4 GHz frequency or a microwave oven or other device that is emitting electromagnetic waves is in use near your "WALKMAN" or the connected Bluetooth device.

- Use your "WALKMAN" or the connected Bluetooth device away from the above devices.

Obstacles (metal, people, walls, etc.) are between your "WALKMAN" and the connected Bluetooth device.

- Avoid or remove any obstacles between your "WALKMAN" and the connected Bluetooth device.

The bit rate setting is improper for the usage environment.

- The connection may become unstable depending on the bit rate setting at which you are sending to the connected Bluetooth device or the usage environment.
-

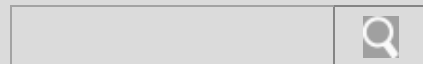

[▶ How to Use](#)

Troubleshooting

General

Music

Video / Photo

Apps

Supplied Software

Video sound is delayed when a Bluetooth connection is made.

The sound may slightly lag behind the video with certain Bluetooth devices.



[▶ How to Use](#)

Troubleshooting

General

Music

Video / Photo

Apps

Supplied Software

Volume cannot be changed when a Bluetooth connection is made.

You cannot adjust the volume with certain Bluetooth devices.

- Adjust the volume on your "WALKMAN."
-



[▶ How to Use](#)

Troubleshooting

General

Music

Video / Photo

Apps

Supplied Software

You cannot hear the sound even if a Bluetooth connection has been made.

The volume of the connected Bluetooth device is muted.

- Unmute the connected Bluetooth device.

The volume is set to zero.

- It may not be possible to adjust the volume of certain connected Bluetooth devices.
Turn up the volume on the Bluetooth device or your "WALKMAN."

Playback of the file has not started.

- Start playing back the file on your "WALKMAN." [\[Details\]](#)

The connected Bluetooth device is not turned on.

- Turn on the connected Bluetooth device and make sure the Bluetooth function is activated.

Bluetooth connection was severed.

- Establish a Bluetooth connection. [\[Details\]](#)

The profile of the connected Bluetooth audio devices does not support AVRCP.

- Make operations on your "WALKMAN."



[▶ How to Use](#)

Troubleshooting

General

Music

Video / Photo

Apps

Supplied Software

You cannot register a Bluetooth device (cannot complete pairing).

Your "WALKMAN" and the Bluetooth device are far apart.

- o Register (pair) them within the range in which Bluetooth connections can be made.
[\[Details\]](#)

The profile of the Bluetooth device to register (pair) differs from that of your "WALKMAN."

- o Registration (pairing) cannot be performed if the profiles are different.
-



[▶ How to Use](#)

Troubleshooting

General

Music

Video / Photo

Apps

Supplied Software

Songs transferred from your computer cannot be deleted on your "WALKMAN."

You cannot delete songs on your "WALKMAN" that were transferred from a computer.

- If songs were transferred using software, delete them with that software. If songs were transferred using the Windows Explorer, delete them with the Windows Explorer.
-



[▶ How to Use](#)

Troubleshooting

General

Music

Video / Photo

Apps

Supplied Software

FM broadcasts are unclear.

The received station is not fully tuned in.

- Select a frequency at which the broadcast can be heard best. [\[Details\]](#)
-

[▶ How to Use](#)**Troubleshooting**

General

Music

Video / Photo

Apps

Supplied Software

FM broadcasts cannot be heard.

The headphones are not connected.

- The headphone cord functions as an antenna. You cannot listen to FM broadcasts when an accessory (not supplied) is connected to the WM-PORT jack, preventing the headphones from being connected.

Bluetooth connection is active.

- You cannot listen to FM broadcasts while Bluetooth connection is active. End the Bluetooth connection, and use the headphones.

HDMI connection is active.

- You cannot listen to FM broadcasts while HDMI connection is active. End the HDMI connection, and use the headphones.
-



[▶ How to Use](#)

Troubleshooting

General

Music

Video / Photo

Apps

Supplied Software

Noise is generated with FM broadcasts.

A mobile phone or other device emitting radio signals is being used nearby.

- When using devices such as mobile phones, keep them away from your "WALKMAN."
-



[▶ How to Use](#)

Troubleshooting

General

Music

Video / Photo

Apps

Supplied Software

There is lots of noise with FM broadcasts, and sound quality is poor.

The radio signal is weak.

- The signal may be weak inside buildings or in vehicles. Find a place where the signal can be received well such as near a window.

The headphone cord is not fully extended.

- The headphone cord functions as an antenna. Extend the headphone cord as much as possible.

If the [Mono/Auto] option is set to [Auto], reception is automatically set according to the situation when receiving.

- Set the [Mono/Auto] option to [Mono] if reception is poor. [\[Details\]](#)
-



[▶ How to Use](#)

Troubleshooting

General

Music

Video / Photo

Apps

Supplied Software

The date and time have been reset.

If you left your "WALKMAN" with the battery charge depleted, the date and time may be reset. This is not a malfunction. Wait for about 10 minutes [\[Details\]](#), then set the date and time again.



[▶ How to Use](#)

Troubleshooting

General

Music

Video / Photo

Apps

Supplied Software

The touch screen does not operate properly.

Fingers other than those performing operations are touching the screen.

- Operations may not be recognized properly if other fingers touch the screen while making operations. Make sure other fingers do not touch the screen while making operations.
-



[▶ How to Use](#)

Troubleshooting

General

Music

Video / Photo

Apps

Supplied Software

Your "WALKMAN" does not operate (does not respond to button operations).

The power is not on.

- Press and hold the  (power) button. [\[Details\]](#)

Your "WALKMAN" contains condensation.

- Let your "WALKMAN" sit for a few hours.

The remaining battery power is low or depleted.

- Charge the battery by means such as connecting your "WALKMAN" to a running computer. [\[Details\]](#)
 - If you charge the battery and nothing changes, press the RESET button to reset your "WALKMAN." [\[Details\]](#)
-



[▶ How to Use](#)

Troubleshooting

General

Music

Video / Photo

Apps

Supplied Software

Your "WALKMAN" does not work properly.

The device connected by USB (computer, etc.) was turned on or off with your "WALKMAN" connected to it.

- Reset your "WALKMAN" by pressing the RESET button of your "WALKMAN." [\[Details\]](#)
Be sure to disconnect your "WALKMAN" before you turn on or off the USB device.
-

[▶ How to Use](#)**Troubleshooting**

General

Music

Video / Photo

Apps

Supplied Software

Battery life is short.

The operating temperature is below 5°C.

- Battery life becomes shorter as a result of battery characteristics. This is not a malfunction.

Battery charging time is not sufficient.

- Charge the battery until the entire battery icon becomes green.

You are using the Bluetooth function.

- More battery charge is consumed because the Bluetooth function transfers data wirelessly. The battery life will be longer if you turn off the connection whenever you are not using it. [\[Details\]](#)

You are using the Wi-Fi function.

- More battery charge is consumed because the Wi-Fi function transfers data wirelessly. The battery life will be longer if you turn off the connection whenever you are not using it. [\[Details\]](#)

You are using the GPS function.

- More battery charge is consumed because the GPS function transfers data wirelessly. The battery life will be longer if you turn off the connection whenever you are not using it.

Display is too bright.

- The battery life will be longer by adjusting the brightness of the screen.

You have not used your "WALKMAN" for more than a year.

- Depending on the conditions under which your "WALKMAN" is used, the battery may have been deteriorated. Consult your nearest Sony dealer.

Usable battery life is half that when new, even after sufficiently charging the battery.

- Your batter may be deteriorated. Consult your nearest Sony dealer.



» [How to Use](#)

Troubleshooting

General

Music

Video / Photo

Apps



Supplied Software

The computer does not recognize your "WALKMAN" even if connected by USB cable.

The USB cable is not connected to a USB connector on your computer properly.

- Disconnect the USB cable, and then reconnect it.
- Use the supplied USB cable.

USB debugging is enabled.

- Some devices or software may not recognize your "WALKMAN" when USB debugging is enabled. Tap the  (Menu) button, then tap [ Settings] - [ Applications] - [Development] - [USB debugging] and uncheck the box.

A USB hub is being used.

- Your "WALKMAN" may not be recognized by the computer if using a USB hub. Connect your "WALKMAN" directly to the computer's USB port.

The USB connector on your computer may have a problem.

- Connect your "WALKMAN" to another USB connector on your computer.

When you use your "WALKMAN" for the first time, or when the battery is low, the battery mark may display and you may not be able to use your "WALKMAN." This is not a malfunction. Wait for about 10 minutes before attempting operations.

Software authentication may take some time. Wait for a while.

Software installation failed.

- Reinstall the software using the installer. Imported data will remain unchanged.

If the problem still persists after performing the remedies above, press the RESET button to reset your "WALKMAN." [\[Details\]](#)



[▶ How to Use](#)

Troubleshooting

General

Music

Video / Photo

Apps

Supplied Software

Your "WALKMAN" becomes unstable while it is connected to the computer.

A USB hub or USB extension cable is being used.

- Your "WALKMAN" may be unstable if using a USB hub or USB extension cable. Connect your "WALKMAN" directly to the computer's USB port.
-



» [How to Use](#)

Troubleshooting

General

Music

Video / Photo

Apps

Supplied Software

Data cannot be transferred.

The USB cable is not connected to a USB connector on your computer properly.

- Disconnect the USB cable, and then reconnect it.

USB debugging is enabled.

- Some devices or software may not recognize your "WALKMAN" when USB debugging is enabled. Tap the (Menu) button, then tap [Settings] - [Applications] - [Development] - [USB debugging] and uncheck the box.

There is not enough free memory space on your "WALKMAN."

- Delete any unnecessary data to increase free space.
- see "Maximum recordable number of songs and time (Approx.) [[Details](#)]," "Maximum recordable time of videos (Approx.) [[Details](#)]," and "Maximum recordable number of photo files (Approx.) [[Details](#)]."

Data with errors is present on your "WALKMAN."

- Back up necessary data, and format your "WALKMAN." [[Details](#)]

You are not using compatible software.

- Install compatible software, and then transfer data.

The data is damaged.

- Delete the data that cannot be transferred from your computer, then import it to your computer again. When importing data to your computer or transferring data to your "WALKMAN," stop other work to avoid data damage.

You may be attempting to transfer a file in a format that cannot be played by your "WALKMAN."

- For information on files that can be transferred, see "Supported formats." [[Details](#)]
Some files may not be transferred, depending on their file specifications.

You have exceeded the maximum number of files that can be transferred to your "WALKMAN."

- See "Maximum recordable number of songs" [[Details](#)] for the maximum number of songs that can be transferred.
- Delete unnecessary songs.



[▶ How to Use](#)

Troubleshooting

General

Music

Video / Photo

Apps

Supplied Software

Only a small amount of data can be transferred to your "WALKMAN."

There is not enough free memory space on your "WALKMAN."

- Delete any unnecessary data to increase free space.

Data that cannot be played on your "WALKMAN" is stored on your "WALKMAN."

- If data that cannot be played on your "WALKMAN" is stored on your "WALKMAN," fewer songs, videos, and photos can be transferred. Transfer back to the computer data other than that which you will play on your "WALKMAN" to increase the available space on your "WALKMAN."
-



[▶ How to Use](#)

Troubleshooting

General

Music

Video / Photo

Apps

Supplied Software

The transfer takes too much time.

You transferred a large file to your "WALKMAN."

- It may take a long time to transfer a large file.
-



[▶ How to Use](#)

Troubleshooting

General

Music

Video / Photo

Apps

Supplied Software

Charging completes very quickly.

If the battery is already almost fully charged when charging begins, little time is needed to reach full charge.

[▶ How to Use](#)**Troubleshooting****General****Music****Video / Photo****Apps****Supplied Software****Your "WALKMAN" cannot charge the battery.**

The USB cable is not connected to a USB connector on your computer properly.

- Disconnect the USB cable, and then reconnect it.
- Use the supplied USB cable.

The battery is charged outside the temperature range of 5°C to 35°C.

- Charge the battery in a temperature range of 5°C to 35°C.

The computer is not on.

- Turn on the computer.

Your computer is in standby (sleep) or hibernation mode.

- Exit from standby (sleep) or hibernation mode.

An AC adapter not compatible with your "WALKMAN" is being used.

- Use an AC adapter (not supplied) compatible with your "WALKMAN" (AC-NWUM60, etc.).

A USB hub is being used.

- Your "WALKMAN" may not charge via a USB hub. Connect your "WALKMAN" directly to the computer's USB port.

Your "WALKMAN" is connected to a computer running an operating system that is not supported.

- Check the system requirements of your computer, and charge with a computer running an operating system that is supported. [\[Details\]](#)

You have not used your "WALKMAN" for more than a year.

- Depending on the conditions under which your "WALKMAN" is used, the battery may be deteriorated. Consult your nearest Sony dealer.

If the problem still persists after performing the remedies above, press the RESET button to reset your "WALKMAN." [\[Details\]](#)

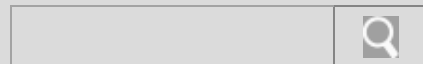

[▶ How to Use](#)

Troubleshooting

General

Music

Video / Photo

Apps

Supplied Software

Content on the DLNA server cannot be played.

Some content cannot be played on your "WALKMAN."



[▶ How to Use](#)

Troubleshooting

General

Music

Video / Photo

Apps

Supplied Software

You cannot return to the screen for controlling playback on other devices.

You can return using the notification panel.



[▶ How to Use](#)

Troubleshooting

General

Music

Video / Photo

Apps

Supplied Software

You cannot send (Throw) content to another device (playback device) and play it back.

Certain content may not be played back on other devices.

Copyright-protected content cannot be played back on other devices.



[▶ How to Use](#)

Troubleshooting

General

Music

Video / Photo

Apps

Supplied Software

Cover art is not displayed.

Cover art data in the appropriate format is not registered to the song.

- Register cover art using the software for transferring. Cover art may not be displayed for songs transferred by the Windows Explorer.
 - Add cover art from the menu.
-



[▶ How to Use](#)

Troubleshooting

General

Music

Video / Photo

Apps

Supplied Software

Songs that are displayed when [All songs] or [Albums] is selected are not displayed when [Folders] is selected.

Songs were not added by dragging and dropping to the [Music] folder.

- Songs displayed when [Folders] is selected are only those placed in the [Music] folder by dragging and dropping.
-

[▶ How to Use](#)**Troubleshooting****General****Music****Video / Photo****Apps****Supplied Software****Songs/videos cannot be played, or photos cannot be displayed.**

The battery charge is depleted.

- Charge the battery fully. [\[Details\]](#)
- If your "WALKMAN" still does not react, even after charging the battery, press the RESET button to reset your "WALKMAN." [\[Details\]](#)

Songs, videos, or photos transferred by drag-and-drop are not in the appropriate data hierarchy levels.

- Place the data in the appropriate folders and data hierarchy levels. [\[Details\]](#)

Transferred files are not in a format that can be played on your "WALKMAN."

- For information on the playable files, see "Supported formats" [\[Details\]](#) Some files may not be played back, depending on their file specifications.

You transferred MP4 audio files to the [Video] folder by drag-and-drop.

- Drag and drop MP4 files to the [Music] folder on your "WALKMAN" when transferring them.

Formatting your "WALKMAN" failed to complete, or you formatted your "WALKMAN" on the computer.

- Retry formatting your "WALKMAN." [\[Details\]](#)

If the problem still persists after performing the remedies above, press the RESET button to reset your "WALKMAN." [\[Details\]](#)



[▶ How to Use](#)

Troubleshooting

General

Music

Video / Photo

Apps

Supplied Software

The screen turns off.

There was no operation made within the time selected in [Screen timeout].

- Press the  (power) button.
-



[▶ How to Use](#)

Troubleshooting

General

Music

Video / Photo

Apps

Supplied Software

Videos and photos transferred from a computer are not displayed in a list.

You transferred videos and photos to your "WALKMAN" from a computer in a format not supported by your "WALKMAN."

- Videos and photos in unsupported formats will not be recognized by your "WALKMAN" and will not appear in a list. [\[Details\]](#)

You renamed a video file that was transferred from a computer to your "WALKMAN," or you moved it to another folder.

- If you rename a video file or move it to another folder, it may not be recognized by your "WALKMAN" and may not appear in a video list.

Data transferred by drag-and-drop is not in the appropriate data hierarchy level.

- Place the data in the appropriate folders and data hierarchy levels. [\[Details\]](#)

Your "WALKMAN" was formatted using the Windows Explorer.

- Format the memory on your "WALKMAN." [\[Details\]](#)

The USB cable was disconnected from your "WALKMAN" while data was being transferred.

- Transfer usable files back to your computer, and format the memory on your "WALKMAN." [\[Details\]](#)



[▶ How to Use](#)

Troubleshooting

General

Music

Video / Photo

Apps

Supplied Software

[Unknown] is displayed for an album name, artist name, etc.

Album or artist name information is not contained in the data.

- Add information such as song, album, or artist name with the software used to transfer songs to your "WALKMAN," then transfer again.
-



[▶ How to Use](#)

Troubleshooting

General

Music

Video / Photo

Apps

Supplied Software

Your "WALKMAN" gets warm.

Your "WALKMAN" may become warm when the battery is being charged and just after charging. Your "WALKMAN" also may get warm temporarily when a large amount of data is transferred. Set your "WALKMAN" aside for a while to allow it to cool down.



[▶ How to Use](#)

Troubleshooting

General

Music

Video / Photo

Apps

Supplied Software

Help guide or an application does not operate.

You cannot use the Help guide or some of the applications while your "WALKMAN" is connected to a computer and USB storage is active.

- Swipe the status bar, then tap [Turn off USB storage] on the notification panel. Tap [Turn off USB storage] displayed on the screen of your "WALKMAN."
-



[▶ How to Use](#)

Troubleshooting

General

Music

Video / Photo

Apps

Supplied Software

Playback does not stop.

With your "WALKMAN," there is no difference between stopping and pausing.

When you tap ,  appears and playback pauses.



[▶ How to Use](#)

Troubleshooting

General

Music

Video / Photo

Apps

Supplied Software

Playback has stopped suddenly.

The remaining battery power is low or depleted.

- Charge the battery by means such as connecting your "WALKMAN" to a running computer. [\[Details\]](#)

You are trying to play a song or video that cannot be played on your "WALKMAN."

- Select and play back a different song or video.

There is a problem with connection to a Bluetooth device that has caused playback to stop.

- Check the connection to the Bluetooth device.
-



[▶ How to Use](#)

Troubleshooting

General

Music

Video / Photo

Apps

Supplied Software

There is no sound from the right channel of the headphones. Or the right channel sound is heard from both sides of the headphones.

The headphone plug is not fully inserted into the jack.

- If the headphones are not connected correctly, sound will not be output properly. Insert the headphone plug into the jack until it clicks. [\[Details\]](#)
-



[▶ How to Use](#)

Troubleshooting

General

Music

Video / Photo

Apps

Supplied Software

Volume cannot be turned up.

You are listening via a Bluetooth connection.

- Turn up the volume on the Bluetooth device.

Media volume level is set to zero.

- Increase the media volume. [\[Details\]](#)

[AVLS (Volume Limit)] is enabled.

- Disable [AVLS (Volume Limit)]. [\[Details\]](#)
-



[▶ How to Use](#)

Troubleshooting

General

Music

Video / Photo

Apps

Supplied Software

Noise can be heard when plugging in or unplugging the headphones.

If you plug in or unplug the headphones while playing music, noise may be generated from the headphones. This is not a malfunction.

- Remove the headphones from your ears when plugging in or unplugging.
-

[▶ How to Use](#)**Troubleshooting**

General

Music

Video / Photo

Apps

Supplied Software

Noise is generated.

A mobile phone or other device emitting radio signals is being used nearby.

- When using devices such as mobile phones, keep them away from your "WALKMAN."

Songs imported from CDs, etc. is damaged.

- Connect your "WALKMAN" to a computer, and use the software you used to transfer the songs or the Windows Explorer to delete the damaged songs. Then import songs from CDs, etc., and transfer them again. When importing data to your computer, close any other applications to avoid data damage.

Transferred files are not in a format that can be played on your "WALKMAN."

- For information on the playable files, see "Supported formats." [\[Details\]](#) Some files may not be played back, depending on their file specifications.

The headphone plug is dirty.

- Clean the headphone plug with a soft dry cloth.
-

[▶ How to Use](#)**Troubleshooting****General****Music****Video / Photo****Apps****Supplied Software****There is no sound.**

The volume level is set to zero.

- Turn the volume up. [\[Details\]](#)

The headphone plug is not inserted firmly into the headphone jack.

- If the headphones are connected improperly, the sound from the headphones will be impaired. Insert the headphone plug until it clicks into place. [\[Details\]](#)

The headphone plug is dirty.

- Clean the headphone plug with a soft dry cloth.

The song that you want to play back is not selected.

- Select the song on your "WALKMAN."

A Bluetooth connection is active.

- Sound is not emitted from the headphones when a Bluetooth connection is active. Deactivate the Bluetooth connection.

An HDMI connection is active.

- Deactivate the HDMI connection.

Accessories are connected to the WM-PORT jack.

- Disconnect accessories from the WM-PORT jack.

Media volume level is set to zero.

- Increase the media volume. [\[Details\]](#)

If the problem still persists after performing the remedies above, press the RESET button to reset your "WALKMAN." [\[Details\]](#)



[▶ How to Use](#)

Troubleshooting

General

Music

Video / Photo

Apps

Supplied Software

[Clear stereo] function is not effective.

The [Clear stereo] function only works with the supplied headphones.

The [Clear stereo] function does not work with Bluetooth connections.



[▶ How to Use](#)

Troubleshooting

General

Music

Video / Photo

Apps

Supplied Software

[VPT (Surround)] function is not effective.

The [VPT (Surround)] function only works with the supplied headphones.



[▶ How to Use](#)

Troubleshooting

General

Music

Video / Photo

Apps



Supplied Software

Your "WALKMAN" is not recognized as USB storage.

The USB connection is turned off.

- Swipe the status bar, then tap [USB connected] on the notification panel followed by [Turn on USB storage] then [OK].

USB debugging is enabled.

- Some devices or software may not recognize your "WALKMAN" when USB debugging is enabled. Tap the  (Menu) button, then tap [ Settings] - [ Applications] - [Development] - [USB debugging] and uncheck the box.
-

[▶ How to Use](#)**Troubleshooting**

General

Music

Video / Photo

Apps

Supplied Software

Software cannot be installed on the computer.

Your computer is using an operating system that is not supported by your "WALKMAN."

- Check the system requirements of your computer. [\[Details\]](#)

Other software is running on Windows.

- If other software is running, it may interfere with installation. Particularly, be sure to quit security software as it can put a heavy load on the computer. To prevent infection by viruses, disconnect your computer from the Internet before quitting security software.

There is not enough free space for the hard drive.

- Check the amount of free hard drive space required to install the application, and delete unnecessary files.

Your account has no administrator privileges, or you have not logged in as the computer's administrator.

- To install the software, log in with an account with administrator privileges or log in as the computer's administrator.

A message dialog is hidden by the install screen, making the install process seem stopped.

- Press and hold the [Alt] key while pressing the [Tab] key several times until the message dialog appears. Then follow instructions in the message.
-



[▶ How to Use](#)

Troubleshooting

General

Music

Video / Photo

Apps

Supplied Software

The progress bar on the install screen does not proceed while installing software. Or, the access lamp of the hard drive does not light for several minutes.

Wait until the installation is completed, because it is progressing properly. Installation may take 30 minutes or more depending on the computer used.
