

SONY[®]

2-635-396-11(1)

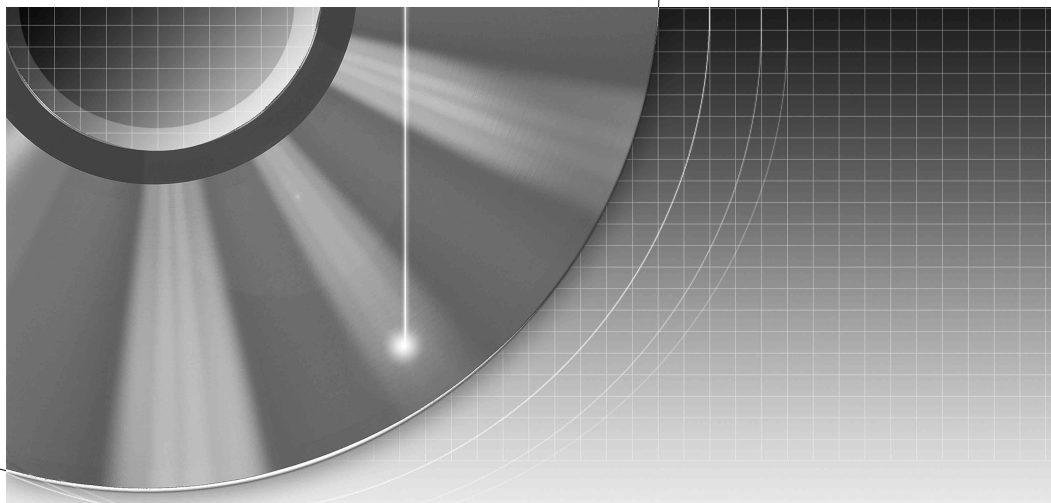

DVD Recorder Home Theatre System

Operating Instructions

DAR-RH7000
DAR-RH1000



© 2005 Sony Corporation

WARNING

To prevent fire or shock hazard, do not expose the unit to rain or moisture. To avoid electrical shock, do not open the cabinet. Refer servicing to qualified personnel only. The mains lead must only be changed at a qualified service shop.

CLASS 1 LASER PRODUCT
LASER KLASSE 1
クラス1 レーザ製品

This appliance is classified as a CLASS 1 LASER product. The CLASS 1 LASER PRODUCT MARKING is located on the laser protective housing inside the enclosure.

CAUTION

The use of optical instruments with this product will increase eye hazard. As the laser beam used in this DVD recorder is harmful to eyes, do not attempt to disassemble the cabinet. Refer servicing to qualified personnel only.

CAUTION	CLASS 1B VISIBLE AND INVISIBLE LASER RADIATION WHEN OPEN. AVOID EXPOSURE TO THE BEAM.
ATTENTION	RADIATION LASER VISIBLE ET INVISIBLES DE CLASSE 1B QUAND L'APPAREIL EST OUVERT. ÉVITEZ L'EXPOSITION AU FASCEAU LASER.
ADVARSEL	KLASSE 1B SYMBLE OG USYMBLE LASERSTRÅLING VED ÅBNING. UNDGÅ UDSETTELSE FOR STRÅLING.
VARNING	KLASSE 1B SYMBLE OCH USYMBLE LASERSTRÅLNING NÄR DENNA DEL ÄR ÖPPNAD. UNDGÅ ATT UTSETTAS ÖFVER STRÅLNINGEN.
VORSICHT	BEI GEBÖRNER AUSSCHNITT DER SICHERHEIT UND UNTERSCHREIBUNG LASERSTRAHUNG DER KLASSE 1B IM GERÄTEINNENRAUM. VERMEIDEN SIE ABER NICHT DIE LASERSTRAHUNG ANZUSEHEN.
PRECAUCION	CUANDO SE ABRE HAY RADIACION LASER DE CLASSE 1B VISIBLE E INVISIBLE. EVITE LA EXPOSICION A LOS RAYOS LASER.
VARO!	AVATTENESSA OLET ALETTÄÄN NÄKYVÄLLÄ JA HÄYVÄTTÖMÄLLÄ LÖYDÄÄN 1B LASERSTRÄHLÖYLE. ÄLÄ HÄYVÄTTÖMÄLLÄ SÄTEEN.
注意	ここを開くと、クラス 1Bの可視レーザー光及び不可視レーザー光が出ます。ビームを直接見たり、触れたりしないでください。

This label is located on the laser protective housing inside the enclosure.

Notice for customers in the United Kingdom and Republic of Ireland

A moulded plug complying with BS1363 is fitted to this equipment for your safety and convenience. Should the fuse in the plug supplied need to be replaced, a 5 AMP fuse approved by ASTA or BSI to BS1362, (i.e., marked with ⚡ or ⚡ mark) must be used.

If the plug supplied with this equipment has a detachable fuse cover, be sure to attach the fuse cover after you change the fuse. Never use the plug without the fuse cover. If you should lose the fuse cover, please contact your nearest Sony service station.

Precautions

- This unit operates on 230 V AC, 50/60 Hz. Check that the unit's operating voltage is identical with your local power supply.
- To prevent fire, do not cover the ventilation of the apparatus with newspapers, table-cloths, curtains, etc. And do not place lighted candles on the apparatus.
- To prevent fire or shock hazard, do not place objects filled with liquids, such as vases, on the apparatus.

VIDEO Plus+ and PlusCode are registered trademarks of Gemstar Development Corporation. The VIDEO Plus+ system is manufactured under license from Gemstar Development Corporation.



Do not throw away the battery with general house waste, dispose of it correctly as chemical waste.

Disposal of Old Electrical & Electronic Equipment (Applicable in the European Union and other European countries with separate collection systems)



This symbol on the product or on its packaging indicates that this product shall not be treated as household waste. Instead it shall be handed over to the

applicable collection point for the recycling of electrical and electronic equipment. By ensuring this product is disposed of correctly, you will help prevent potential negative consequences for the environment and human health, which could otherwise be caused by inappropriate waste handling of this product. The recycling of materials will help to conserve natural resources. For more detailed information about recycling of this product, please contact your local city office, your household waste disposal service or the shop where you purchased the product.

Precautions

On safety

Should any solid object or liquid fall into the cabinet, unplug the system and have it checked by qualified personnel before operating it any further.

When disconnecting the mains leads, do not touch the metallic part of the jacks or plugs.

About the hard disk drive

The hard disk has a high storage density, which enables long recording durations and quick access to the written data. However, it can easily be damaged by shock, vibration or dust, and should be kept away from magnets. To avoid losing important data, observe the following precautions.

- Do not apply a strong shock to the recorder.
- Do not place the recorder in a location subject to mechanical vibrations or in an unstable location.
- Do not place the recorder on top of a hot surface, such as a VCR or amplifier (receiver).
- Do not use the recorder in a place subject to extreme changes in temperature (temperature gradient less than 10 °C/hour).
- Do not move the recorder with its mains lead connected.
- Do not disconnect the mains lead while the power is on.
- When disconnecting the mains lead, turn off the power and make sure that the hard disk drive is not operating (the clock is displayed in the front panel display and all recording or dubbing has stopped).
- Do not move the recorder for one minute after you have unplugged the mains lead.
- Do not attempt to replace or upgrade the hard disk by yourself, as this may result in malfunction.

If the hard disk drive should malfunction, you cannot recover lost data. The hard disk drive is only a temporary storage space.

About repairing the hard disk drive

- The contents of the hard disk drive may be checked in case of repair or inspection during a malfunction or modification. However, the contents will not be backed up or saved by Sony.
- If the hard disk needs to be formatted or replaced, it will be done at the discretion of Sony. All contents of the hard disk drive will be erased, including contents that violate copyright laws.

On power sources

- The system is not disconnected from the AC power source (mains) as long as it is connected to the wall outlet, even if the system itself has been turned off.
- If you are not going to use the system for a long time, be sure to disconnect the system from the wall outlet. To disconnect the AC power cord (mains lead), grasp the plug itself; never pull the cord.
- Before disconnecting the AC power cord (mains lead), check that the recorder's hard disk is not operating (recording or dubbing) on the front panel display.
- Do not put any object into the holes on the set (fan ventilation holes, jacks, etc.). Electric shock may result.

On placement

- Place the system in a location with adequate ventilation to prevent heat build-up in the system.
- At high volume, over long periods of time, the cabinet becomes hot to the touch. This is not a malfunction. However, touching the cabinet should be avoided. Do not place the system in a confined space where ventilation is poor as this may cause overheating.
- Do not block the ventilation holes for the cooling fan by putting anything on the system. The system is equipped with a high power amplifier. If the ventilation

holes are blocked, the system can overheat and malfunction.

- Do not place the system on a soft surface such as a rug that might block the ventilation holes.
- Do not install the system in a confined space, such as a bookcase or built-in cabinet.
- Do not place the system in a location near heat sources, or in a place subject to direct sunlight, excessive dust, or mechanical shock.
- Do not place the system in an inclined position. It is designed to be operated in a horizontal position only.
- Keep the system and discs away from equipment with strong magnets, such as microwave ovens, or large loudspeakers.
- Do not put any objects on the recorder as they may fall, damage the surface, or cause malfunction.
- Do not put objects in front of the speakers as they may fall over when loud sound is output.
- If the system is brought directly from a cold to a warm location, moisture may condense inside the DVD Recorder Home Theatre System and cause damage to the lenses. When you first install the system, or when you move it from a cold to a warm location, wait for about 30 minutes before operating the system.
- Do not place anything around the rear of the subwoofer as air pressure from the subwoofer's duct may knock down.
- Do not insert anything into the rear openings of the subwoofer. This may cause electric shock or injury.
- Do not insert anything into the subwoofer's duct, as sound quality may be affected.

On recording

- Note that the contents of the recording cannot be compensated for under any and all conditions, including conditions that may arise due to a malfunction of this unit.
- Make trial recordings before making the actual recording.

Copyrights

- Television programmes, films, video tapes, discs, and other materials may be copyrighted. Unauthorized recording of such material may be contrary to the provisions of the copyright laws. Also, use of this recorder with cable television transmission may require authorization from the cable television transmitter and/or programme owner.
- This product incorporates copyright protection technology that is protected by U.S. patents and other intellectual property rights. Use of this copyright protection technology must be authorized by Macrovision, and is intended for home and other limited viewing uses only unless otherwise authorized by Macrovision. Reverse engineering or disassembly is prohibited.
- This system incorporates with Dolby^{*1} Digital and Dolby Pro Logic (II) adaptive matrix surround decoder and the DTS^{*2} Digital Surround System.

^{*1} Manufactured under license from Dolby Laboratories. "Dolby," "Pro Logic," and the double-D symbol are trademarks of Dolby Laboratories.

^{*2} Manufactured under license from Digital Theater Systems, Inc. "DTS" and "DTS Digital Surround" are trademarks of Digital Theater Systems, Inc.

Copy guard function

Since the recorder has a copy guard function, programmes received through an external tuner (not supplied) may contain copy protection signals (copy guard function) and as such may not be recordable, depending on the type of signal.

IMPORTANT NOTICE

Caution: This system is capable of holding a still video image or on-screen display image on your television screen indefinitely. If you leave the still video image or on-screen display image displayed on your TV for an extended period of time you risk permanent damage to your television screen. Plasma display panels and projection televisions are especially susceptible to this.

If you have any questions or problems concerning your recorder, please consult your nearest Sony dealer.

About this manual

Check your model name

The instructions in this manual are for two models: DAR-RH7000 and DAR-RH1000. Check your model name by looking at the front panel of the recorder.

- In this manual, the internal hard disk drive is written as “HDD,” and “disc” is used as a general reference for the HDD, DVDs, or CDs unless otherwise specified by the text or illustrations.
- Instructions in this manual describe the controls on the remote. You can also use the controls on the recorder or other unit(s) if they have the same or similar names as those on the remote.
- The on-screen display illustrations used in this manual may not match the graphics displayed on your TV screen.
- The explanations regarding DVDs in this manual refer to DVDs created on this recorder. The explanations do not apply to DVDs that are created on other recorders and played back on this recorder.

Table of Contents

WARNING	2
Precautions	2
Ways to Use Your DVD Recorder Home Theatre System	7
Quick Guide to Disc Types	8
Hookups and Settings	12
Overview	12
Step 1: Unpacking	12
Step 2: Connecting the Speaker System	14
Step 3: Connecting the FM/AM Aerials	21
Step 4: Connecting the Subwoofer and Recorder	22
Step 5: Connecting the TV Aerial	23
Step 6: Connecting the TV and Recorder	24
Step 7: Connecting the Mains Leads	28
Connecting the Recorder to Other Equipment	29
Step 8: Easy Setup	34
Seven Basic Operations	36
1. Inserting and Formatting a DVD Disc (Disc Info)	36
2. Recording a Programme	38
3. Playing the Recorded Programme (Title List)	39
4. Displaying the Playing Time and Play Information	41
5. Changing the Name of a Recorded Programme	43
6. Labelling and Protecting a Disc	45
7. Playing the Disc on Other DVD Equipment (Finalize)	46
Timer Recording	48
Before Recording	48
Timer Recording (Standard/Video Plus+)	50
Checking/Changing/Cancelling Timer Settings (Timer List)	55
Recording From Connected Equipment	57
Playback	60
Playing	60
Searching for a Title/Chapter/Track, etc.	66
Playing MP3 Audio Tracks or JPEG Image Files	67
Erasing and Editing	71
Before Editing	71
Erasing and Editing a Title	72
Creating and Editing a Playlist	76
Dubbing (HDD ↔ DVD)	79
Before Dubbing	79
Dubbing	81

Speaker Surround Options	84
Selecting the Sound Field	84
Reinforcing Bass Frequencies (DSGX)	86
Enjoying TV or VCR Sound From the Speaker System	86
<hr/>	
Other Operations	87
Enjoying the Radio	87
Controlling TVs With the Remote	88
<hr/>	
Settings and Adjustments	90
Aerial Reception and Language Settings (Settings)	90
Video Settings (Video)	95
Audio Settings (Audio)	97
Recording and Parental Control Settings (Features)	98
Speaker Settings (Speaker)	100
Disc Settings/Factory Settings (Options)	103
Easy Setup (Resetting the System)	104
<hr/>	
Additional Information	105
Troubleshooting	105
Self-diagnosis Function (When letters/numbers appear in the display)	112
Notes About This Recorder	113
Specifications	114
Guide to Parts and Controls	116
Glossary	121
Language Code List	123
Area Code	123
Index	124

Ways to Use Your DVD Recorder Home Theatre System

Recording/Playback

Compatible media and reference pages

Quick access to recorded titles
– Title List

→ **HDD** **+RW** **-RWVR** **-RWVideo** **+R** **-R**
“3. Playing the Recorded Programme (Title List)” on page 39

Play the beginning of a title
while it is being recorded
– Chasing Playback

→ **HDD** **-RWVR**
“Playing back from the beginning of the programme you are currently recording (Chasing Playback)” on page 64

Watching one title while
recording another
– Simultaneous Rec and Play

→ **HDD** **+RW** **-RWVR** **-RWVideo** **+R** **-R**
VCD **CD** **DATA CD**
“Playing a previous recording while making another (Simultaneous Rec and Play)” on page 65

Dubbing/Editing

Compatible media and reference pages

Creating your own programme
– Playlist

→ **HDD** **-RWVR**
“Creating and Editing a Playlist” on page 76

Copying a recorded title to and
from the HDD
– Dubbing (HDD ↔ DVD)

→ **HDD** **+RW** **-RWVR** **-RWVideo** **+R** **-R**
“Dubbing (HDD ↔ DVD)” on page 79

Speaker Surround Options

Compatible media and reference pages















Listening multi-channel sound
with the 5.1ch speakers

→ **DVD**
“Selecting the Sound Field” on page 84

A list of recordable and playable discs is on page 8.

Quick Guide to Disc Types

Recordable and playable discs

Type	Disc logo	Icon used in this manual	Formatting (new discs)	Compatibility with other DVD players (finalizing)
Hard disk drive (internal)			(Formatting unnecessary)	Dub HDD contents to a DVD to play on other DVD players
DVD+RW	 DVD + ReWritable  DVD + ReWritable		Automatically formatted in +VR mode	Playable on DVD+RW compatible players (automatically finalized)
DVD-RW	VR mode  *2		Format in VR mode (page 36)	Playable only on VR mode compatible players (finalization unnecessary)
	Video mode  		Format in Video mode (page 36)	Playable on most DVD players (finalization necessary) (page 46)
DVD+R			Automatically formatted	Playable on most DVD players (finalization necessary) (page 46)
DVD+R DL				
DVD-R			Automatically formatted	Playable on most DVD players (finalization necessary) (page 46)

Usable disc versions (as of March 2005)

- 8x-speed or slower DVD+RWs
- 6x-speed or slower DVD-RWs (Ver.1.1, Ver.1.2 with CPRM^{*1})
- 16x-speed or slower DVD+Rs
- 16x-speed or slower DVD-Rs (Ver.2.0, Ver.2.1)
- 2.4x-speed DVD+R DL (Double Layer) discs

“DVD+RW,” “DVD-RW,” “DVD+R,” “DVD+R DL,” and “DVD-R” are trademarks.

^{*1} CPRM (Content Protection for Recordable Media) is a coding technology that protects copyrights for images.

^{*2} This logo applies to 4x and 6x speed DVD-RW discs.

	Recording Features				Editing Features			
	Rewrite (page 48)	Auto Chapter (page 98)	Manual Chapter (page 75)	Record 16:9 sizes (page 54)	Change title name (page 43)	Erase title (page 74)	A-B Erase (page 73)	Playlist (page 76)
	Yes	Yes	Yes	Yes	Yes	Yes	Yes	Yes
	Yes	Yes	No	No	Yes	Yes	Yes	No
	Yes	Yes	Yes	Yes	Yes	Yes	Yes	Yes
	Yes	Yes	No	Yes ^{*3}	Yes	Yes	No	No
	No	Yes	No	No	Yes	Yes ^{*4}	No	No
	No	Yes	No	Yes ^{*3}	Yes	Yes ^{*4}	No	No









Discs that cannot be recorded on

- 8 cm discs
- DVD-R DL (Dual Layer) discs
- DVD-Rs in VR mode (Video Recording format)

^{*3} Only if the recording mode is LSP, SP, HSP, or HQ, and "DVD Rec. Picture Size" is set to "16:9."

^{*4} Erasing titles does not free up disc space.

Playable discs

Type	Disc logo	Icon used in this manual	Characteristics
DVD VIDEO			Discs such as movies that can be purchased or rented.
DVD-R DL	—		DVD-R Dual Layer discs that were recorded on other equipment. This recorder recognizes DVD-R Dual Layer discs as DVD Video compatible discs.
VIDEO CD			VIDEO CDs or CD-Rs/CD-RWs in VIDEO CD/Super VIDEO CD format.
CD			Music CDs or CD-Rs/CD-RWs in music CD format that can be purchased.
DATA CD	—		CD-ROMs/CD-Rs/CD-RWs containing MP3 audio tracks or JPEG image files.
8 cm DVD+RW/ DVD-RW/DVD-R	—	—	8 cm DVD+RW, DVD-RW, and DVD-R recorded with a DVD video camera. (Still images recorded with a DVD video camera cannot be played.)

“DVD VIDEO” and “CD” are trademarks.

Discs that cannot be played

- PHOTO CDs
- CD-ROMs/CD-Rs/CD-RWs that are not recorded in music CD or Video CD format, or do not contain MP3 or JPEG files
- Data part of CD-Extras
- DVD-ROMs that are not recorded in DVD Video format
- DVD Audio discs
- DVD-RAMs
- HD layer on Super Audio CDs
- DVD VIDEOS with a different region code (page 11)
- DVD-Rs recorded in VR mode (Video Recording format)

Note

When playing DTS surround sound on a CD or DVD, you can hear the sound from this speaker system only. The audio signals are not output from the LINE output jacks on the recorder.

Maximum recordable number of titles

Disc	Number of titles*
HDD	300
DVD-RW/DVD-R	99
DVD+RW/DVD+R	49
DVD+R DL	49

* The maximum length for each title is eight hours.

Note on playback operations of DVD VIDEOS/VIDEO CDs

Some playback operations of DVD VIDEOS/VIDEO CDs may be intentionally set by software producers. Since this recorder plays DVD VIDEOS/VIDEO CDs according to the disc contents the software producers designed, some playback features may not be available. Also, see the instructions supplied with the DVD VIDEOS/VIDEO CDs.

Region code (DVD VIDEO only)

Your recorder has a region code printed on the rear of the unit and will only play DVD VIDEOS (playback only) labelled with identical region codes. This system is used to protect copyrights. DVD VIDEOS labelled  will also play on this recorder.

If you try to play any other DVD VIDEO, the message “Playback prohibited by region code.” will appear on the TV screen. Depending on the DVD VIDEO, no region code indication may be labelled even though playing the DVD VIDEO is prohibited by area restrictions.

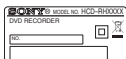

Region code

Music discs encoded with copyright protection technologies

This product is designed to play back discs that conform to the Compact Disc (CD) standard. Recently, various music discs encoded with copyright protection technologies are being marketed by some record companies. Please be aware that among those discs, there are some that do not conform to the CD standard and may not be playable by this product.

Note on DualDiscs

A DualDisc is a two sided disc product which mates DVD recorded material on one side with digital audio material on the other side. However, since the audio material side does not conform to the Compact Disc (CD) standard, playback on this product is not guaranteed.

Notes

- Some DVD+RWs/DVD+Rs, DVD-RWs/DVD-Rs, or CD-RWs/CD-Rs cannot be played on this recorder due to the recording quality or physical condition of the disc, or the characteristics of the recording device and authoring software. The disc will not play if it has not been correctly finalized. For more information, see the operating instructions for the recording device.
- You cannot mix VR mode and Video mode on the same DVD-RW. To change the disc's format, reformat the disc (page 36). Note that the disc's contents will be erased after reformatting.
- You cannot shorten the time required for recording even with high-speed discs.
- It is recommended that you use discs with “For Video” printed on their packaging.
- You cannot add new recordings to DVD+Rs, DVD-Rs, or DVD-RWs (Video mode) that contain recordings made on other DVD equipment.
- In some cases, you may not be able to add new recordings to DVD+RWs that contain recordings made on other DVD equipment. If you do add a new recording, note that this recorder will rewrite the DVD menu.
- You cannot edit recordings on DVD+RWs, DVD-RWs (Video mode), DVD+Rs, or DVD-Rs that are made on other DVD equipment.
- If the disc contains PC data unrecognizable by this recorder, the data may be erased.
- You may not be able to record on some recordable discs, depending on the disc.

Overview

Complete the following steps to start using this DVD recorder home theatre system.

Step 1: Unpacking (page 12)



Step 2: Connecting the Speaker System (page 14)



Step 3: Connecting the FM/AM Aerials (page 21)



Step 4: Connecting the Subwoofer and Recorder (page 22)



Step 5: Connecting the TV Aerial (page 23)



Step 6: Connecting the TV and Recorder (page 24)



Step 7: Connecting the Mains Leads (page 28)



Step 8: Easy Setup (page 34)

Steps 1 to 4 are for the speaker system; steps 5 and 6 for the recorder. After finishing all of the hookups, connect the mains leads in step 7, and start setting up the system in “Step 8: Easy Setup.”

Notes

- Plug cords securely to prevent unwanted noise.
- See the instructions supplied with the components to be connected.
- You cannot connect this recorder to a TV that does not have a SCART or video input jack.
- Be sure to disconnect the mains lead of each component before connecting.

Step 1: Unpacking

Check that you have the following items.

- DVD recorder (1)
- Mains lead (1)
- TV aerial cable (1)
- Active subwoofer (1)
- Speakers (5)
- AM loop aerial (1)
- FM wire aerial (1)
- Speaker cords (short) (3)
- Speaker cords (long) (2)
- System cord (1)
- Food pads for the active subwoofer*¹ (4)
- Remote commander (remote) (1)
- R6 (size AA) batteries (2)
- Operating Instructions (1)
- Hookup Guide (card) (1)

The following is also included for speaker installation.

For DAR-RH7000:

- Speaker stands (2)
- Covers of speaker stands (2)
- Screws (4)
- Foot pads*² (20)

For DAR-RH1000:

- Wall-mount pads (8)

*¹Attach to the bottom of the subwoofer.

*²Attach to the bottom or rear of the speakers.

Inserting batteries into the remote

You can control the recorder and the speaker system using the supplied remote. Insert two Size R6 (AA) batteries by matching the ⊕ and ⊖ ends on the batteries to the markings inside the compartment. When using the remote, point the remote at  (remote sensor) on the recorder.

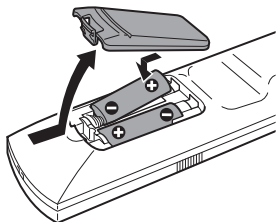

Notes

- To operate a non Sony TV, set the code number of the TV's manufacturer (page 88).
- Use the batteries correctly to avoid possible leakage and corrosion. Do not touch the liquid with bare hands should leakage occur. Observe the following:
 - Do not use a new battery with an old battery, or batteries of different manufacturers.
 - Do not attempt to recharge the batteries.
 - If you do not intend to use the remote for an extended period of time, remove the batteries.
 - If battery leakage occurs, wipe out any liquid inside the battery compartment, and insert new batteries.
- Do not expose the remote sensors (marked  on the recorder) to strong light, such as direct sunlight or lighting apparatus. The system may not respond to the remote.

Step 2: Connecting the Speaker System

For DAR-RH7000

Connect the speaker system using the supplied speaker cords, matching the colours of the terminals with the cords. For details on front speaker connection and speaker stands, see page 17.

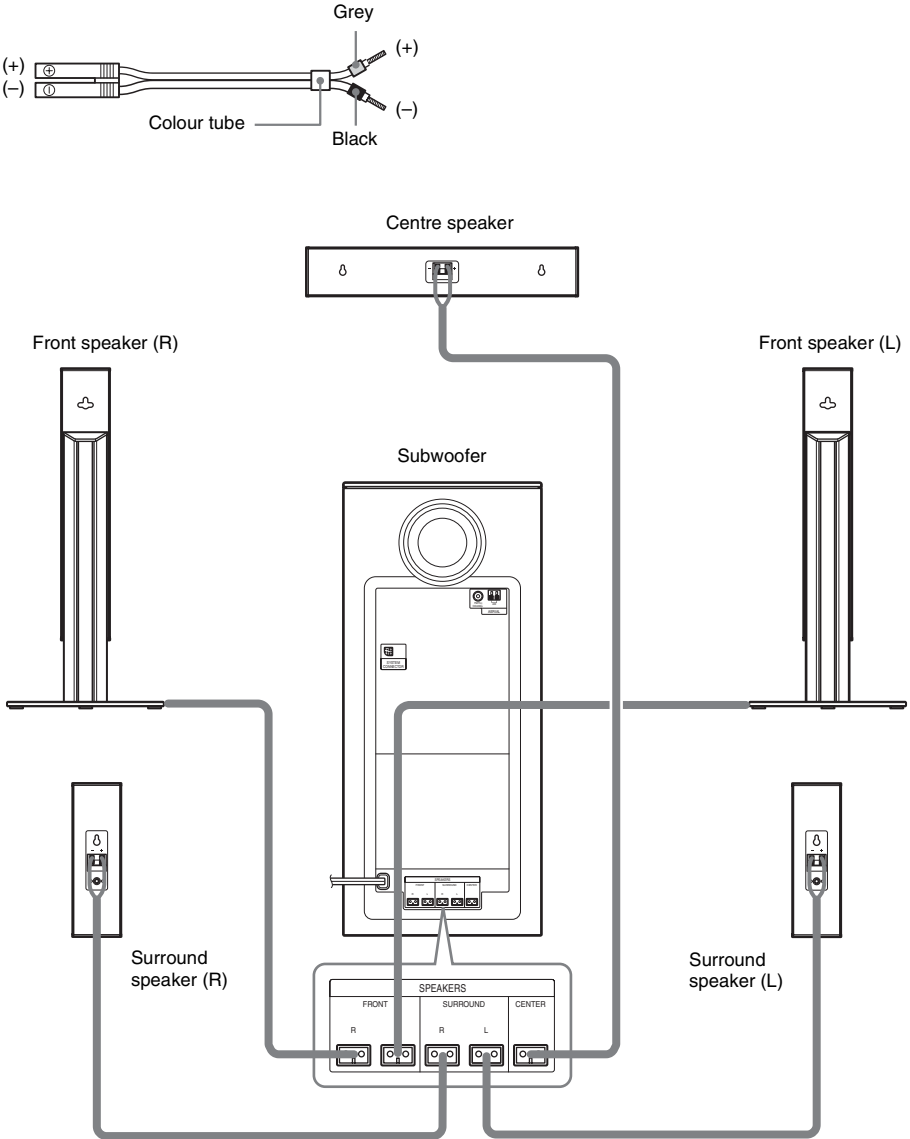

For DAR-RH1000

Connect the speaker system using the supplied speaker cords, matching the colours of the terminals with the cords.

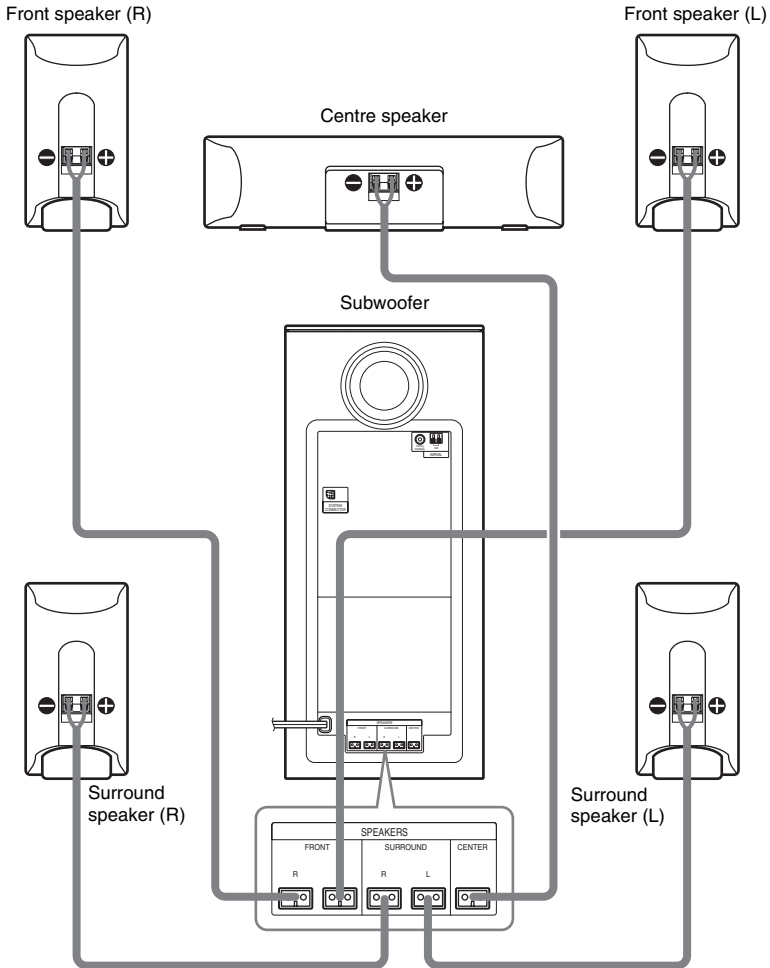
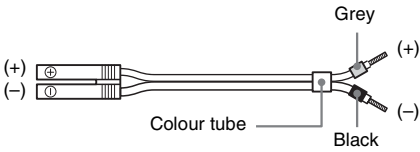

Notes

- Do not set the speakers in an inclined position.
- Do not place the speakers in locations that are:
 - Extremely hot or cold.
 - Dusty or dirty.

- Very humid.
- Subject to vibration.
- Subject to direct sunlight.
- Do not connect any speakers other than those supplied with this system.
- Use caution when placing the speakers and/or speaker stands (not supplied) attached to the speakers on a specially treated floor (waxed, oiled, polished, etc.), as staining or discoloration may result.
- Cover the floor with a cloth when connecting.
- Be sure to match the speaker cord polarity with the component terminals: ⊕ to ⊕ (grey), ⊖ to ⊖ (black). If reversed, the sound will lack bass and may be distorted.

Notes on speaker cord treatment

- Do not insert the speaker cord insulation in the speaker terminals. Bend the stripped cord at the insulation before connecting.

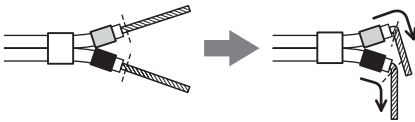

- To avoid short-circuiting the speakers, make sure speaker cord conductors do not touch the neighbouring conductors or terminal.

Example:

Too much insulation is removed. Conductors are touching each other.

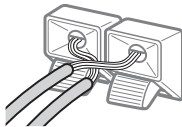

Conductors are splayed, and touching neighbouring terminal.

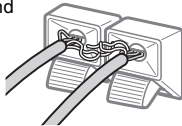

After connecting the system components and the mains leads, you can check for a speaker short-circuit using the test tone (page 102). If the test tone is not output, or is output from a speaker other than indicated in the front panel display, check the speaker connection.

Note

If you connect the speakers incorrectly, or turn up the volume while the speakers are short-circuited, the POWER indicator on the subwoofer flashes and the system enters standby mode. If this happens, disconnect the mains lead, wait about two minutes, and then reconnect to turn on the system.

Positioning the speakers

For the best possible surround sound, all speakers other than the subwoofer should be the same distance from the listening position (A).

However, this system allows you to place the centre speaker up to 1.6 m closer (B) and the surround speakers up to 4.6 m closer (C) to the listening position.

The front speakers can be placed from 1.0 to 7.0 m (A) from the listening position.

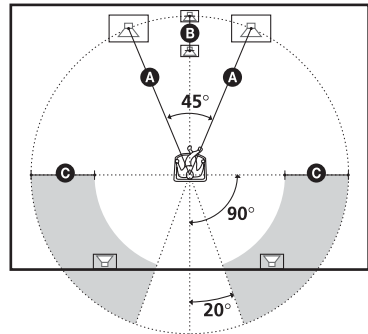

Notes

- Do not place the centre speaker and surround speakers farther away from the listening position than the front speakers.
- If you change the speaker positions after Easy Setup (page 34), change the “Distance” and “Size” settings in “Speaker” setup accordingly (page 100).

Note on subwoofer placement

If the subwoofer is placed too close to a CRT TV or projector, magnetic leakage may interfere with the video signals and cause colour irregularity. Should this happen, turn off the TV or the projector, wait for 15 to 30 minutes, and then turn it on again. If the problem persists, try the following:

- Position the subwoofer at least 0.3 m away from the TV or the projector.
- Move any nearby magnetic object away from the subwoofer (healthcare devices, toys, etc.). Magnetic latches on TV stands may also cause a problem.

Installing the speakers (DAR-RH7000)

Attach the front speakers to the supplied speaker stands.

- 1 Thread the speaker cord through the hole in the bottom of the speaker stand.

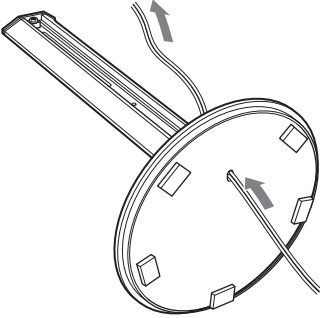

- 2 Thread the speaker cord through the post of the speaker stand, and connect it to the speaker terminals. Ensure the rear holes of the speaker are oriented as illustrated below.

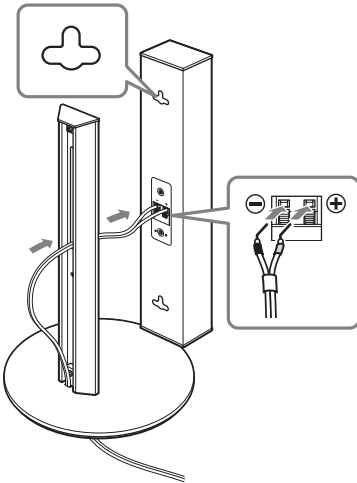

- 3 Securely attach the speaker to the stand with the supplied screws after adjusting the height of the speaker.

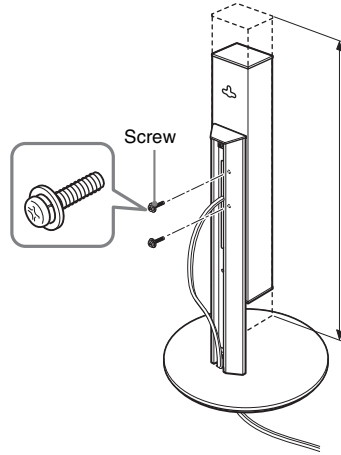

- 4 Take up the slack of the speaker cord.

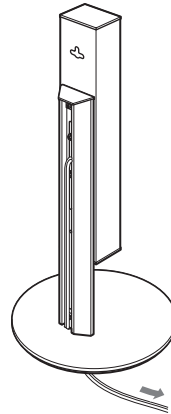

5 Attach the cover.

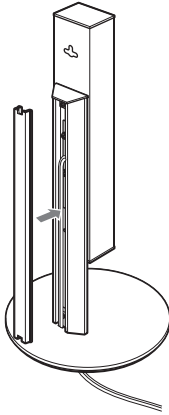

Notes

- Set both speakers to the same height.
- You can install the front and surround speakers on optional speaker stands (WS-FV20 or WS-FV11).

When detaching the speakers from their stands

Insert a flathead screwdriver (not supplied) into the notch of the cover, and remove the cover from the stand.

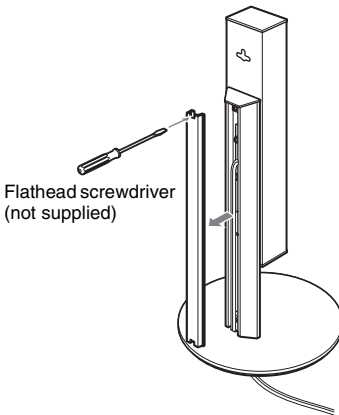

Note

Detach the speaker carefully to prevent pinching your fingers between the speaker and speaker stand.

To attach the supplied foot pads

If you are to place the centre speaker on a rack, attach the supplied foot pads to the bottom of the speaker. Make sure that the hole on the back of the speaker is in the right direction, as illustrated below.

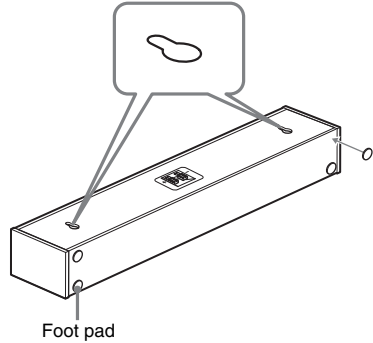

Hint

When placing the front speakers or the surround speakers vertically, attach the supplied foot pads to the bottom face of each speaker.

To install the speakers on a wall

The front speakers can be wall mounted, either vertically or horizontally.

To mount the front speakers horizontally, follow the centre speaker installation procedure on page 20.

- 1 Prepare screws (not supplied) that are suitable for the hole on the back of each speaker.

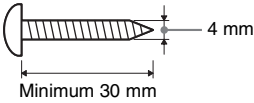

Front speaker

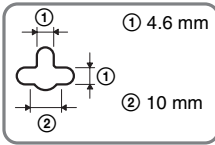

Centre and surround speaker

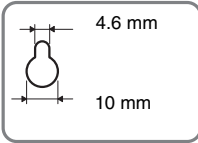

- 2 Fasten the screws to the wall. The screws should protrude 8 to 10 mm.

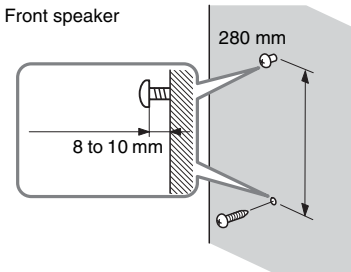

Front speaker

Centre speaker

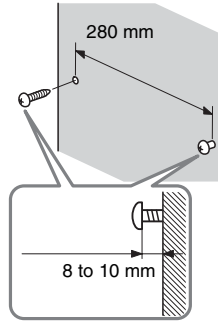

Surround speaker

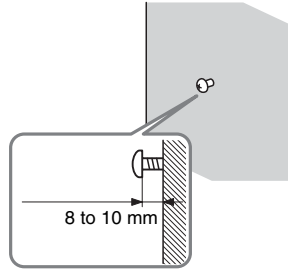

- 3 Attach the supplied foot pads to the speakers, and hang the speakers on the screws. Make sure that the rear hole is oriented correctly before hanging the speaker.

Front speaker

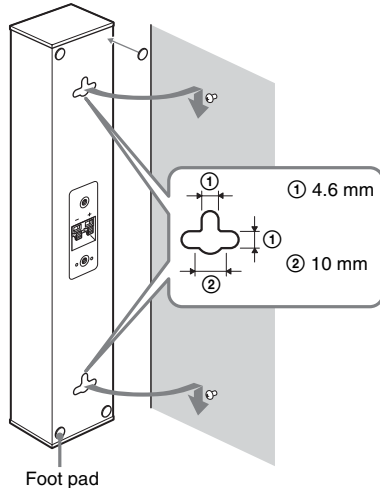

Centre speaker

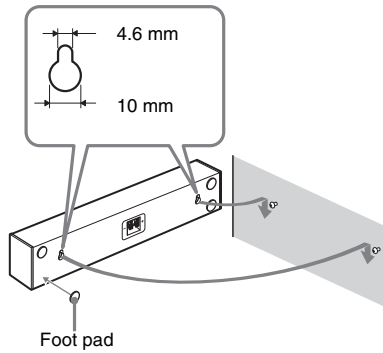

Surround speaker

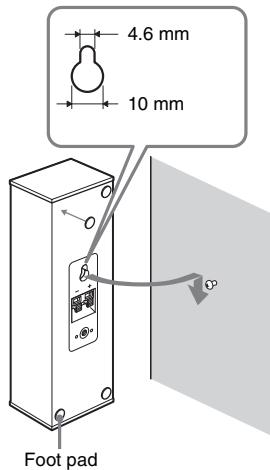

Installing the speakers on a wall (DAR-RH1000)

- 1 Prepare screws (not supplied) that are suitable for the hole on the back of each speaker.

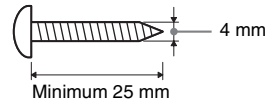

Speaker rear hole

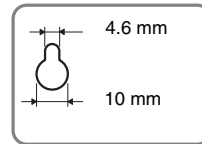

- 2 Fasten the screws to the wall. The screws should protrude 8 to 9 mm.

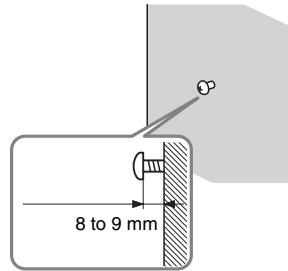

- 3 Attach the supplied wall-mount pads on the rear of the speaker.

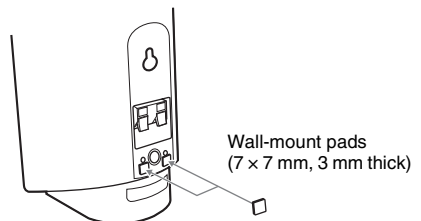

Notes

- If you do not set the speaker correctly, the speaker may fall down and cause injury.
- Use screws that are suitable for the wall material and strength. In the case of a plaster board wall, attach the screws securely to a beam and fasten them to the wall.
- Install the speakers on a vertical and flat wall where reinforcement is applied.
- Contact a screw shop or installer regarding the wall material or screws to be used.
- Sony is not responsible for accident or damage caused by improper installation, insufficient wall strength, improper screw installation, or natural calamity, etc.

4 Hang the speakers on the screws.

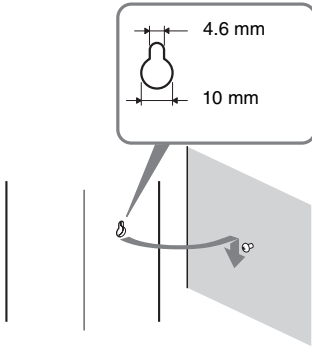

Notes

- Use screws that are suitable for the wall material and strength. In the case of a plaster board wall, attach the screws securely to a beam and fasten them to the wall.
- Install the speakers on a vertical, flat wall where reinforcement is applied.
- Contact a screw shop or installer regarding the wall material or screws to be used.
- Sony is not responsible for accident or damage caused by improper installation, insufficient wall strength or improper screw installation, natural calamity, etc.

Step 3: Connecting the FM/AM Aerials

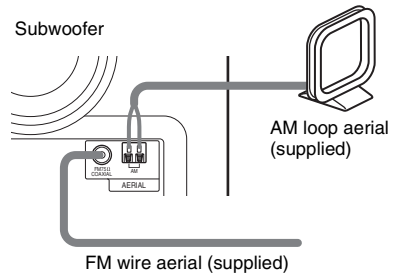

Hints

- AM loop aerial's cord (A) and (B) can be connected to either terminal.

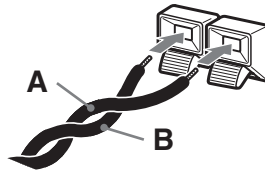

- If FM reception is poor, use a 75-ohm coaxial cable (not supplied) to connect the system to an outdoor FM aerial as shown below.

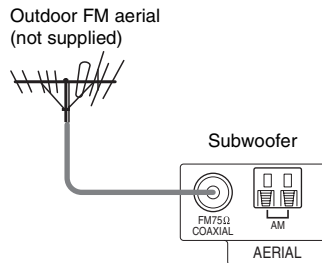

Notes

- To prevent noise pickup, keep the AM loop aerial away from the system and other equipment.
- Be sure to fully extend the FM wire aerial.
- Keep the FM wire aerial as horizontal as possible.

Step 4: Connecting the Subwoofer and Recorder

Connect the subwoofer and recorder using the supplied system cord.

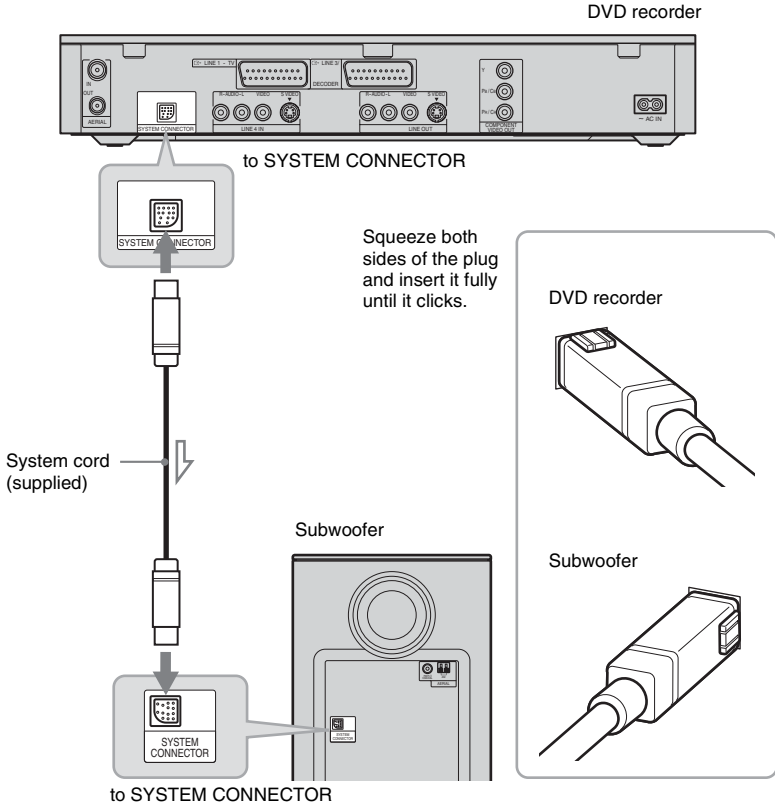

Step 5: Connecting the TV Aerial

Connect the TV aerial cable following the steps below. Do not connect the mains lead until you reach “Step 7: Connecting the Mains Leads” (page 28).

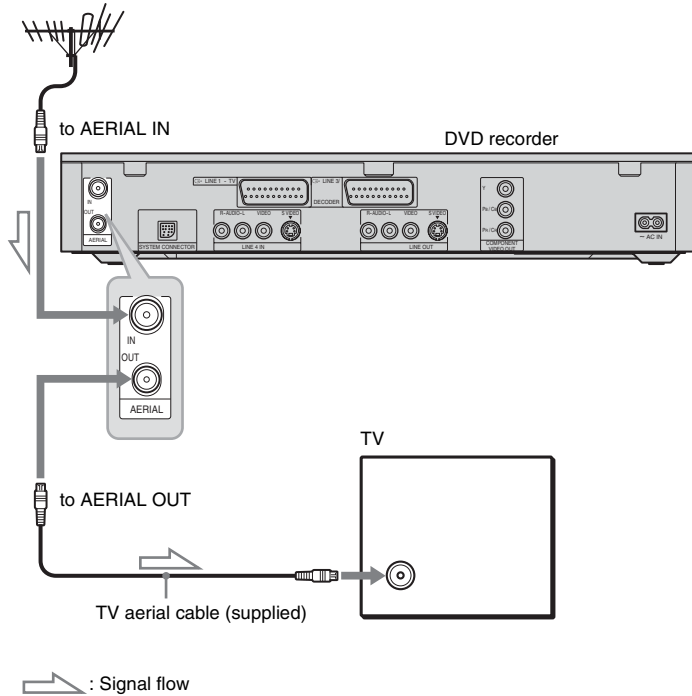

- 1** Disconnect the TV aerial cable from your TV and connect it to **AERIAL IN** on the rear panel of the recorder.
- 2** Connect **AERIAL OUT** of the recorder to the aerial input of your TV, using the supplied TV aerial cable.

Step 6: Connecting the TV and Recorder

Connect a video cord to view pictures (not supplied). Select one of following patterns **A** through **D** according to the type of input jack on your TV monitor or projector.

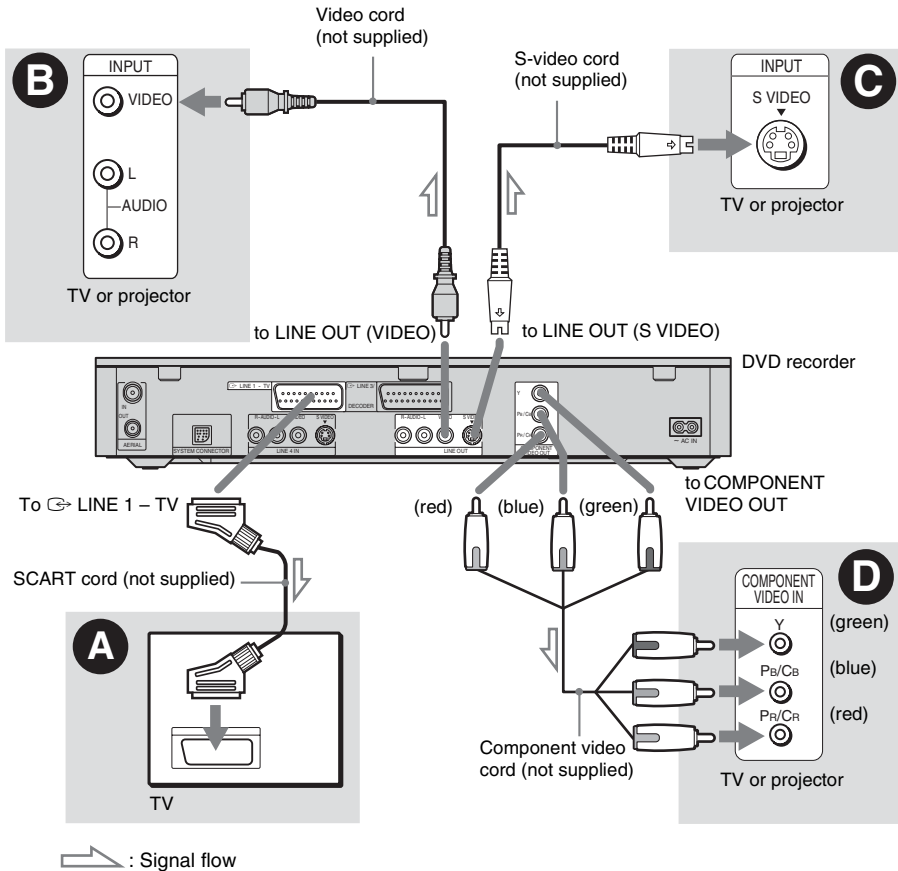

Notes

- Do not connect more than one type of video cord between the recorder and your TV at the same time.
- The LINE jacks do not output DTS audio signals of CDs or DVDs. You can hear DTS sound from this speaker system only.

A Connecting to a SCART input jack

Connect using a SCART cord (not supplied) to the LINE 1-TV jack and your TV. Be sure of a firm connection to avoid hum and noise.

See the operating instructions supplied with the TV to be connected. When you set “Line1 Output” to “S Video” or “RGB” in “Easy Setup” (page 34), use a SCART cord that conforms to the selected signal.

B Connecting to a video input jack

Connect using a video cord (not supplied) to the yellow LINE OUT (VIDEO) jack. You will enjoy standard quality images.

C Connecting to an S VIDEO input jack

Connect using an S-video cord (not supplied) to the LINE OUT (S VIDEO) jack. You will enjoy high quality images.

D Connecting to component video input jacks (Y, P_B/C_B, P_R/C_R)

Connect the COMPONENT VIDEO OUT jacks using a component video cord (not supplied) or three video cords (not supplied) of the same kind and length. You will enjoy accurate colour reproduction and high quality images.

If your TV accepts progressive 525p/625p format signals, you must use this connection and set “Component Out” in “Video” setup to “On” (page 96). Then press PROGRESSIVE on the remote to send progressive video signals. For details, see “Using the PROGRESSIVE button” on page 26.

When playing “wide screen” images

Some recorded images may not fit your TV screen. To change the picture size, see page 95.

If you are connecting to a VCR

Connect your VCR to the LINE 3/DECODER jack on the recorder (page 29).

Notes

- Do not connect more than one type of video cord between the recorder and your TV at the same time.
- You cannot use the PROGRESSIVE button with the connections **B** and **C**.

- When you connect the recorder to your TV via a SCART jack, the TV’s input source is set to the recorder automatically when you start playback. If necessary, press  TV/DVD to return the input to TV.
- For correct SMARTLINK connection, you will need a SCART cord that has the full 21 pins. See your TV’s instruction manual as well for this connection.
- If you connect this recorder to a TV with SMARTLINK, set “Line1 Output” to “Video” in “Easy Setup.”

About the SMARTLINK features (for SCART connections only)

If the connected TV (or other connected equipment such as a set top box) complies with SMARTLINK, NexTVview Link^{*3}, MEGALOGIC^{*1}, EASYLINK^{*2}, CINEMALINK^{*2}, Q-Link^{*3}, EURO VIEW LINK^{*4}, or T-V LINK^{*5}, this recorder automatically runs the SMARTLINK function after you complete the connection pattern **A** on page 24 (the SMARTLINK indicator lights up when you turn on your TV). You can enjoy the following SMARTLINK features.

- **Preset Download**
You can download the tuner preset data from your TV to this recorder, and tune the recorder according to that data in “Easy Setup.” This further simplifies the “Easy Setup” procedure. Be careful not to disconnect the cables or exit the “Easy Setup” function during this procedure (page 34).
- **TV Direct Rec**
You can easily record what you are currently watching (page 38).
- **One Touch Play**
You can turn on the recorder and TV, set the TV’s input to the recorder, and start playback with one touch of the  (play) button (page 61).
- **One Touch Menu**
You can turn on the recorder and TV, set the TV to the recorder’s channel, and display the Title List menu with one touch of the TITLE LIST button (page 61).
- **One Touch Timer**
You can turn on the recorder and TV, set the TV to the recorder’s channel, and display the timer programming menu with one touch of the TIMER button (page 51).
- **Automatic Power Off**
The recorder will turn off automatically if the recorder is not used after you turn off the TV.

- **NexTView Download**

You can easily set the timer by using the NexTView Download function on your TV. See your TV's instruction manual.

*1 "MEGALOGIC" is a registered trademark of Grundig Corporation.

*2 "EASYLINK" and "CINEMALINK" are trademarks of Philips Corporation.

*3 "Q-Link" and "NexTView Link" are trademarks of Panasonic Corporation.

*4 "EURO VIEW LINK" is a trademark of Toshiba Corporation.

*5 "T-V LINK" is a trademark of JVC Corporation.

Hint

SMARTLINK also works with TVs or other equipment having EPG Timer Control, EPG Title Download, and Now Recording functions. For details, see the operating instructions supplied with your TV or other equipment.

Notes

- The SMARTLINK features are available only when "Video" is selected in "Line1 Output."
- Not all TVs respond to the functions above.

Using the PROGRESSIVE button

By using the PROGRESSIVE button, you can select the signal format in which the recorder outputs video signals: interlace or progressive.

- 1** Connect the recorder using the COMPONENT VIDEO OUT jacks (pattern  on page 25).
- 2** Set "Component Out" in "Video" setup to "On" (page 96).
- 3** Press the PROGRESSIVE button. "PROGRE" appears in the front panel display when the recorder outputs progressive signals.

◆ **Progressive**

Select this when:

- your TV accepts progressive signals, and,
- the TV is connected to the COMPONENT VIDEO OUT jacks.

Note that the pictures will not be clear or no picture will appear if you select progressive signal output when either of the above conditions is not met.

◆ **Interlace**

Select this when:

- your TV does not accept progressive signals, or,
- your TV is connected to jacks other than the COMPONENT VIDEO OUT jacks (LINE 2 OUT (VIDEO or S VIDEO)).

Hint

When you select progressive signal output, you can fine-tune the signal according to the type of software you are watching (page 96).

Note

Consumers should note that not all high definition television sets are fully compatible with this product and may cause artifacts to be displayed in the picture. In the case of 525/625 progressive scan picture problems, it is recommended that the user switch the connection to the 'standard definition' output. If there are questions regarding our TV set compatibility with this model 525p/625p DVD recorder, please contact our customer service centre.

Connecting an audio cord

If you listen via your TV's speakers, connect the LINE OUT jacks of the recorder to the audio input jacks of your TV.

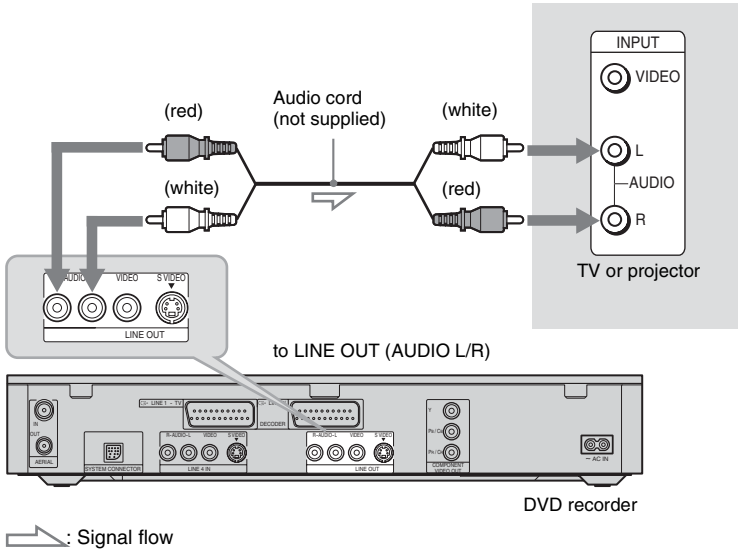

Notes

- Do not connect your TV's audio output jacks to the LINE IN (AUDIO L/R) jacks at the same time. This will cause unwanted noise to come from your TV's speakers.
- Do not connect the LINE 4 IN (AUDIO L/R) and LINE OUT (AUDIO L/R) jacks to your TV's audio jacks at the same time. This will cause unwanted noise to come from your TV's speakers.
- The LINE jacks do not output DTS audio signals of CDs or DVDs. You can hear DTS sound from this speaker system only.

Step 7: Connecting the Mains Leads

If you are connecting additional devices, go to “Connecting the Recorder to Other Equipment” (page 29) first.

After completing all of the hookups, connect the supplied mains lead to the AC IN terminal of the recorder, and then plug the recorder, subwoofer, and TV mains leads into the mains.

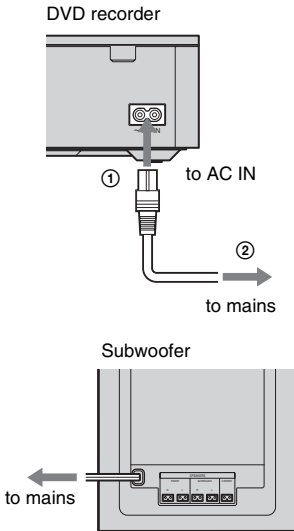

Before operating, you must wait a short while until the front panel display lights up and the recorder has entered standby mode. You can then start setting up the system – go to “Step 8: Easy Setup” (page 34).

To turn the system on and off

Press **I/⏻**.

When you turn off the system, the system enters standby mode and the ON/STANDBY indicator on the subwoofer lights up in red.

Note

After the subwoofer’s mains lead is disconnected, the ON/STANDBY indicator may remain lit red for a while.

Connecting the Recorder to Other Equipment

Before connecting the recorder's mains lead, connect any other equipment (VCR, satellite tuner, PAY-TV decoder, etc.) to the LINE IN jacks of the recorder. See also the operating instructions supplied with the connected equipment.

To record on this recorder, see "Recording From Connected Equipment" (page 57). To listen to the sound of other equipment through the speaker system, see "Enjoying TV or VCR Sound From the Speaker System" (page 86).

Connecting a VCR or similar device

To connect to the LINE 3 jack

Connect a VCR or similar recording device to the LINE 3/DECODER jack of this recorder.

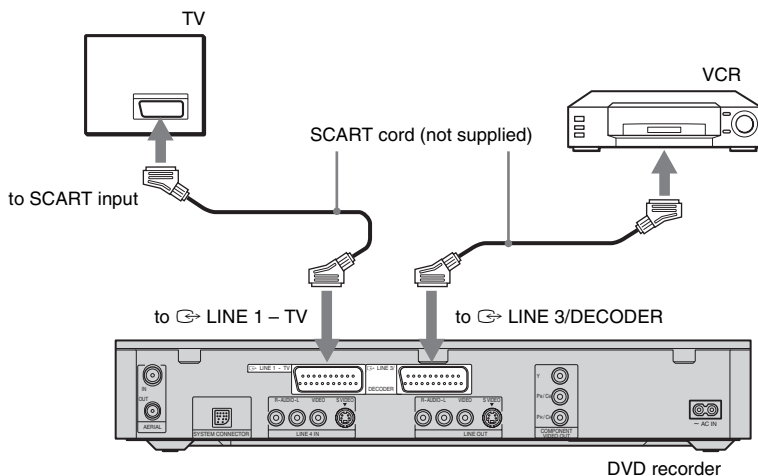

Notes

- Pictures containing copy protection signals, which prohibit copying, cannot be recorded.
- If you pass the recorder signals via the VCR, you may not receive a clear image on your TV screen.

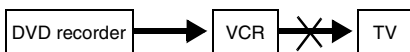

Be sure to connect your VCR to the DVD recorder and your TV in the order shown below. To watch video tapes, connect to a second line input on your TV ("Line input 2" below).

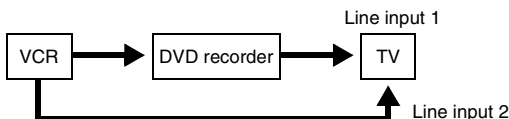

- SMARTLINK features are not available for devices connected via the DVD recorder's LINE 3/DECODER jack.
- When you record to a VCR from this DVD recorder, do not switch the input source to TV by pressing the TV/DVD button on the remote.
- If the recorder's mains lead is disconnected, you will not be able to view images from the connected VCR.
- DTS audio signals of CDs/DVDs are output only to this speaker system, not to the LINE jacks.

To connect to the LINE 2 IN or LINE 4 IN jacks

Connect a VCR or similar recording device to the LINE 2 IN or LINE 4 IN jacks of this recorder. If you are connecting to the LINE 2 IN jacks and the equipment has an S-video jack, you can use an S-video cord instead of a video cord.

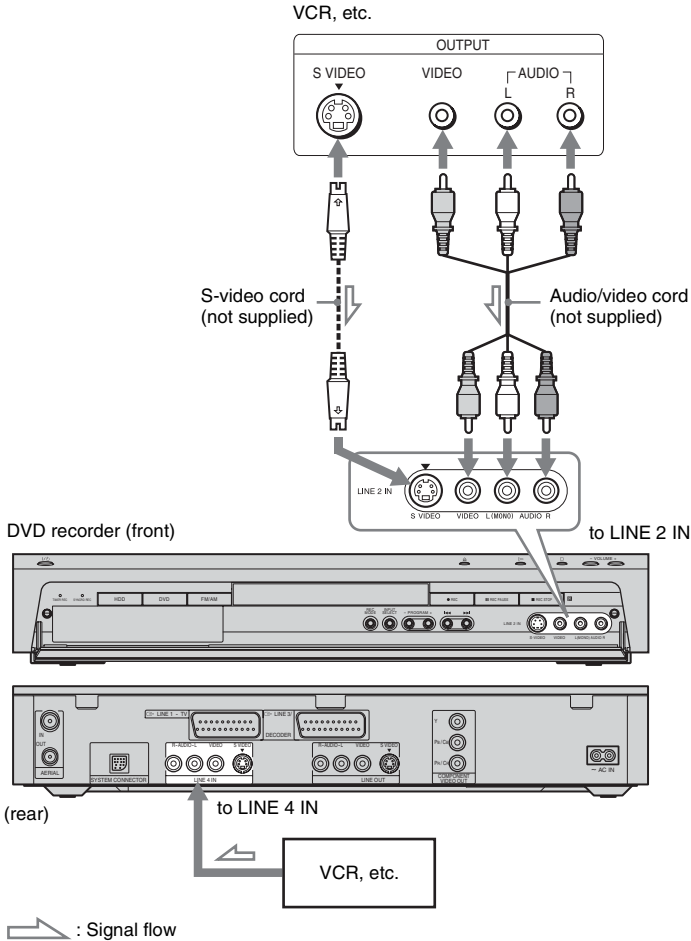

Hint

When connected equipment outputs only monaural sound, use an audio cord to distribute monaural signal to both left and right channels (not supplied).

Notes

- Do not connect the output jack of this recorder to another equipment's input jack with the other equipment's output jack connected to the input jack of this recorder. Noise (feedback) may result.
- Do not connect more than one type of video cord between the recorder and your TV at the same time (i.e. yellow video cord and S-video cord).

Connecting to a satellite or digital tuner

Connect a satellite or digital tuner to this recorder using the LINE 3/DECODER jack. Disconnect the recorder from the mains when connecting the tuner.

To use the Synchro-Rec function, see below.

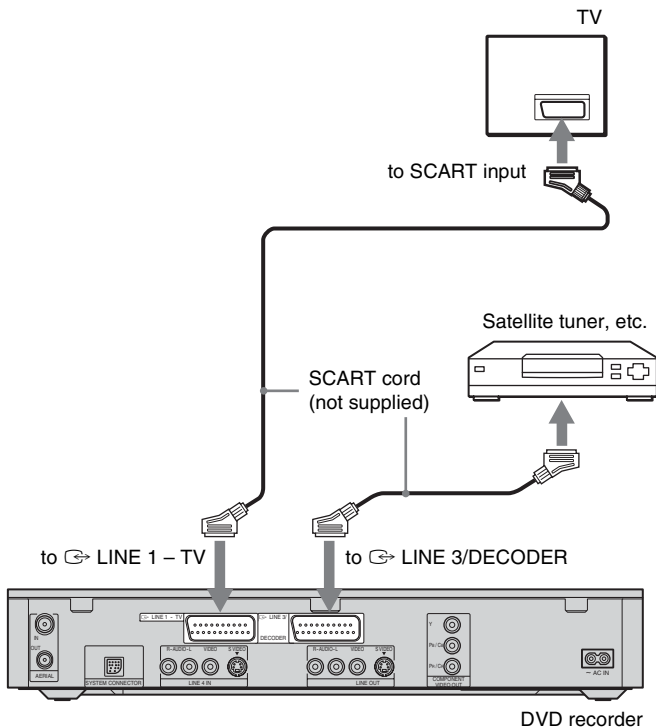

If the satellite tuner can output RGB signals

This recorder accepts RGB signals. If the satellite tuner can output RGB signals, connect the TV SCART connector on the satellite tuner to the LINE 3/DECODER jack, and set “Line3 Input” of “Scart Setting” to “Video/RGB” in “Video” setup (page 96). Note that this connection and setup disable the SMARTLINK function. If you want to use the SMARTLINK function with a compatible set top box, see the instructions supplied with the set top box.

If you want to use the Synchro Rec function

This connection is necessary to use the Synchro-Recording function. See “Recording from connected equipment with a timer (Synchro Rec)” on page 57.

Set “Line3 Input” of “Scart Setting” in “Video” setup (page 96) according to the specifications of

your satellite tuner. See your satellite tuner’s instructions for more information.

If you are using a B Sky B tuner, be sure to connect the tuner’s VCR SCART jack to the LINE 3/DECODER jack. Then set “Line3 Input” of “Scart Setting” according to the specifications of the VCR SCART jack on your satellite tuner.

Notes

- Do not set “Line3 Input” of “Scart Setting” in “Video” setup to “Decoder.”
- Synchro-Recording does not work with some tuners. For details, see the tuner’s operating instructions.
- If you disconnect the recorder’s mains lead, you will not be able to view the signals from the connected tuner.
- DTS audio signals of CDs/DVDs are output only to this speaker system, not to the LINE jacks.

Connecting a PAY-TV/Canal Plus decoder

You can watch or record PAY-TV/Canal Plus programmes if you connect a decoder (not supplied) to the recorder. Disconnect the recorder from the mains when connecting the decoder.

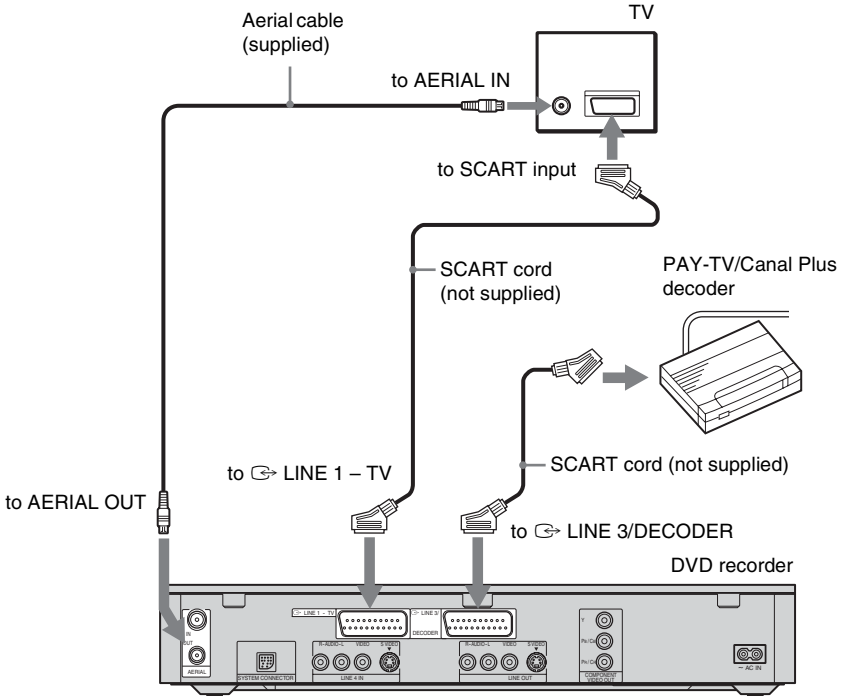

Note

If the recorder's mains lead is disconnected, you will not be able to view images from the connected decoder.

Setting PAY-TV/Canal Plus channels

To watch or record PAY-TV/Canal Plus programmes, set your recorder to receive channels using the on-screen display.

In order to set the channels correctly, be sure to follow all the steps below.

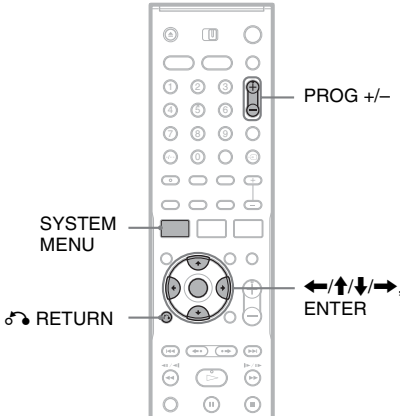

1 Press SYSTEM MENU.
The System Menu appears.

2 Select "SETUP," and press ENTER.

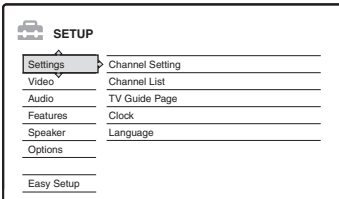

3 Select "Video," and press ENTER.

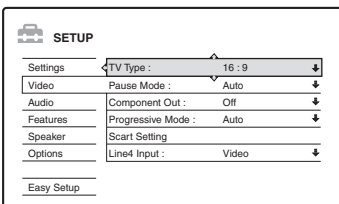

4 Select "Scart Setting," and press ENTER.

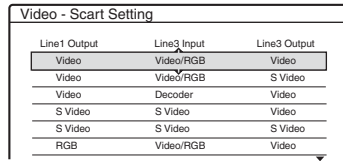

5 Press ↑/↓ to select "Video" or "RGB" for "Line1 Output," "Decoder" for "Line3 Input," and "Video" for "Line3 Output," and press ENTER.

The "Video" setup display appears again.

6 Press ↶ RETURN to return the cursor to the left column.

7 Select "Settings," and press ENTER.

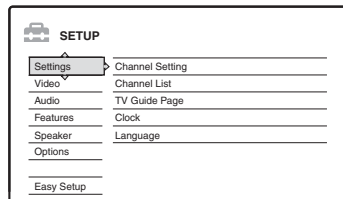

8 Select "Channel Setting," and press ENTER.

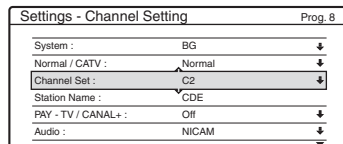

9 Press PROG +/- to select the desired programme position.

Selected programme position

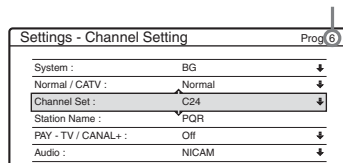

10 Select "System," and press ENTER.

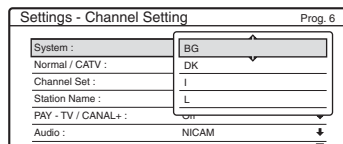

- 11** Press **↑/↓** to select an available TV system, **BG, DK, I, or L**, and press **ENTER**.
To receive broadcasts in France, select **“L.”**

- 12** Select **“Normal/CATV,”** and press **ENTER**.

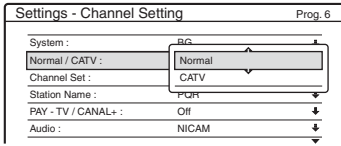

- 13** Select **“Normal,”** and press **ENTER**.

To preset CATV (Cable Television) channels, select **“CATV.”**

- 14** Select **“Channel Set,”** and press **ENTER**.

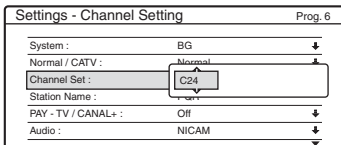

- 15** Select the **PAY-TV/Canal Plus** channel, and press **ENTER**.

- 16** Select **“PAY-TV/CANAL+,”** and press **ENTER**.

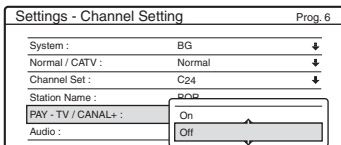

- 17** Select **“On,”** and press **ENTER**.

To return to the previous step

Press **↶ RETURN**.

Note

When you set “Line3 Input” to “Decoder” in step 5 above, you will not be able to select “L3” because Line 3 will become a dedicated line for the decoder.

Step 8: Easy Setup

Make the basic adjustments by following the on-screen instructions in “Easy Setup.”

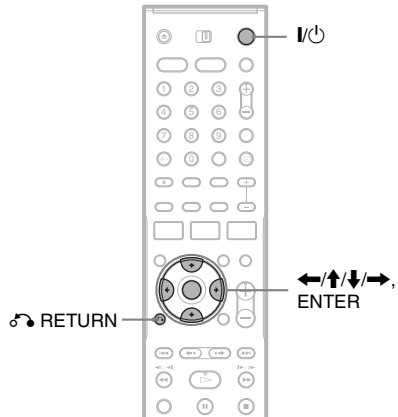

- 1** Press **I/⏻** to turn on the recorder and set the input selector on your TV so that the signal from the recorder appears on your TV screen.

A message regarding initial settings appears.

- If this message does not appear, select “Easy Setup” from “SETUP” in the System Menu to run “Easy Setup” function (page 104).

- 2** Press **ENTER**.

Follow the on-screen instructions to make the following settings.

◆ OSD

Select the language for the on-screen displays.

◆ Tuner System

Select your country or language.

The programme position order will be set according to the country you set.

To set the programme positions manually, see page 90.

- If you live in a French speaking country that is not listed on the display, select “ELSE.”

◆ Clock

The recorder will automatically search for a clock signal.

- If a clock signal cannot be found, set the clock manually using **↶/↴/↵/↷**, and press **ENTER**.

◆ TV Type

If you have a wide-screen TV, select “16:9.”
 If you have a standard TV, select either “4:3 Letter Box” (shrink to fit) or “4:3 Pan Scan” (stretch to fit). This will determine how “wide-screen” images are displayed on your TV.

◆ Component Out

If you are using the COMPONENT VIDEO OUT jack, select “On.”

◆ Line3 Input

If you will connect a decoder to the LINE 3/ DECODER jack, select “Yes.”

◆ Line1 Output

To output video signals, select “Video.”
 To output S video signals, select “S Video.”
 To output RGB signals, select “RGB.”
 Select “Video” to enjoy the SMARTLINK features.

- If you set “Component Out” to “On,” you cannot select “RGB.”
- If you set “Line3 Input” to “Yes,” you cannot select “S Video.”

◆ Room Size

Select a room size from “Small,” “Medium,” or “Large.” Distance of each speaker will be set automatically.

Speaker Distance Settings

	Front	Centre	Surround
Small (default)	1.6 m	1.6 m	1.6 m
Medium	2.4 m	2.2 m	2.4 m
Large	3.4 m	3.0 m	3.4 m

3 Press ENTER when “Finish” appears.

“Easy Setup” is finished.

To return to the previous step

Press ⏪ RETURN.

To fine-tune your speaker system

Make detailed adjustments to each speaker’s distance, loudness, and position settings. See “Speaker Settings (Speaker)” on page 100.

🔧 Hints

- If you want to change each setting, see “Settings and Adjustments” (page 90).
- If you want to run “Easy Setup” again, select “Easy Setup” from “SETUP” in the System Menu (page 104).

Note

If the Room Size display does not appear, check that the subwoofer is turned on, and that the system cord is connected securely.

**Basic hookups and settings are complete.
 You are ready to start using the system.**

1. Inserting and Formatting a DVD Disc (Disc Info)

Inserting a disc

+RW -RWVR -RW_{Video} +R -R DVD
VCD CD DATA CD

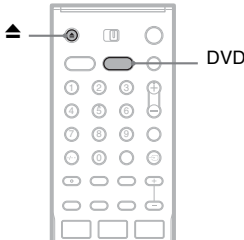

- 1 Press DVD.
- 2 Press \blacktriangle (open/close), and place a disc on the disc tray.

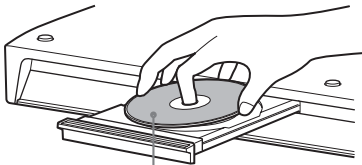

Recording/playback side facing down

- 3 Press \blacktriangle (open/close) to close the disc tray.
Wait until "LOAD" disappears in the front panel display.
Unused DVDs are formatted automatically.

Formatting a DVD disc (Disc Info)

+RW -RWVR -RW_{Video}

New discs are automatically formatted when inserted. If necessary, you can manually re-format a DVD+RW or DVD-RW disc to make a blank disc. For DVD-RWs, you can select a recording format (VR mode or Video mode) according to your needs (page 8).

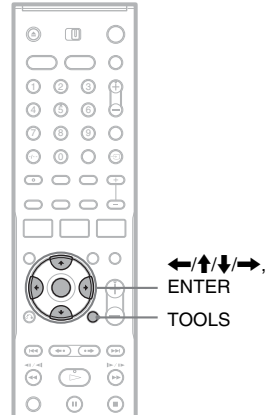

- 1 Insert a disc.
See "Inserting a disc" above.
- 2 Press TOOLS.
The TOOLS menu appears.

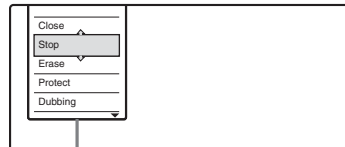

Options for the disc or picture

The TOOLS menu displays options applicable to the entire disc (e.g. disc protection), recorder (e.g. audio settings during recording), or multiple items on a list menu (e.g. erasing multiple titles). The displayed options differ depending on the situation and disc type.

3 Move the cursor down the TOOLS menu until “Disc Info” is selected, and press ENTER.

Example: When a DVD-RW (VR mode) is inserted.

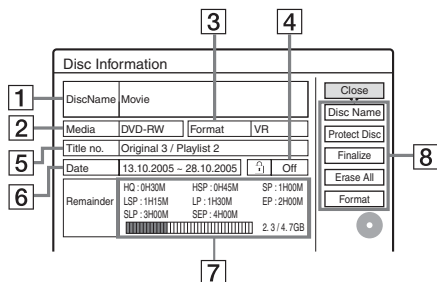

- 1 “Disc Name” (DVD only)
- 2 “Media”: Disc type
- 3 “Format”: Recording format type (DVD-RW only)
- 4 “On”/“Off”: Indicates whether protection is set (DVD-RW in VR mode only)
- 5 “Title no.”: Total number of titles
- 6 “Date”: Dates of when the oldest and the most recent titles were recorded (DVD only)
- 7 “Continuous Rem. Time”/“Remainder” (approximate)
 - The remaining recording time in each of the recording modes
 - Disc space bar
 - Remaining disc space/total disc space
- 8 Disc setting buttons
 - “Disc Name” (page 45)
 - “Protect Disc” (page 45)
 - “Finalize”/“Unfinalize” (page 46)
 - “Erase All” (page 75)
 - “Format”

Available settings differ depending on the disc type.

4 Select “Format,” and press ENTER.

5 Select “OK,” and press ENTER.

For DVD-RWs, select “VR” or “Video,” and press ENTER.

All contents on the disc are erased.

💡 Hints

- By reformatting, you can change the recording format on DVD-RWs, or record again on DVD-RWs that have been finalized.
- For DVD+RWs and DVD-RWs (Video mode), you can check free space and title location on the disc using the Disc Map display (page 75).

Note

On this model, 1 GB (read “gigabyte”) is equivalent to 1 billion bytes. The larger the number, the larger the disc space.

2. Recording a Programme

HDD +RW -RW/V R -RW/Video +R -R

This section introduces the basic operation to record the current TV programme to the hard disk (HDD) or to a disc (DVD). For an explanation of how to make timer recordings, see page 48.

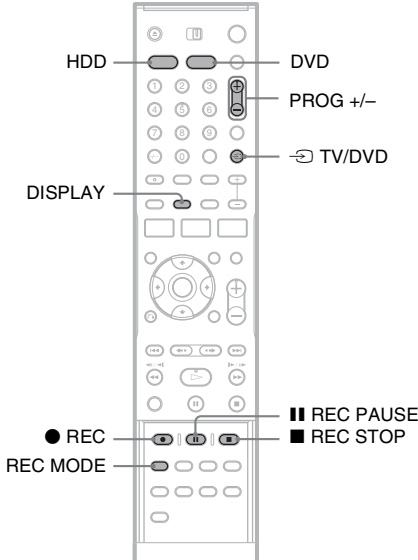

1 Press HDD or DVD.

When you record to a DVD, insert a recordable DVD (see “Inserting a disc” on page 36).

2 Press PROG +/- to select the programme position or input source you want to record.

3 Press REC MODE repeatedly to select the recording mode.

Each time you press the button, the display on the TV screen changes as follows:



For more details about the recording mode, see page 48.

4 Press ● REC.

Recording starts.

Recording stops automatically after eight hours of continuous recording or when the HDD or DVD is full.

To stop recording

Press ■ REC STOP located beneath the remote control cover.

Note that it may take a few seconds for recorder to stop recording.

To pause recording

Press ■ REC PAUSE located beneath the remote control cover.

To restart recording, press the button again.

To watch another TV programme while recording

If your TV is connected to the LINE 1 – TV jack, set your TV to the TV input using the ↺ TV/DVD button and select the programme you want to watch.

If your TV is connected to the LINE OUT or COMPONENT VIDEO OUT jacks, set the TV to TV input using the ↺ TV/DVD button (page 88).

TV Direct Rec

If you use the SMARTLINK connection, you can easily record what you are watching on your TV. When the TV is turned on, press ● REC. The recorder automatically turns on and starts recording what you are watching on the TV.

Note

If “TV” appears in the front panel display, you cannot turn off the TV or change the programme position during TV Direct Rec. To turn off the function, set “TV Direct Rec” to “Off” in “Features” setup (page 98).

About the Teletext function

Some broadcasts include a Teletext service* in which all programme information (title, date, channel, recording start time etc.) is stored daily. When recording a programme, the recorder automatically takes the programme name from the Teletext pages and stores it as the title name. For details, see “TV Guide Page” on page 93.

Note that the Teletext information will not appear on your TV screen. To view the Teletext information on your TV screen, press TV/DVD on the remote to switch the input source to your TV.

* not available in some areas.

Hint

If you do not want to watch TV while recording, you can turn off the TV. When using a decoder, make sure to leave it on.

Notes

- After pressing REC, it may take a short while to start recording.
- You cannot change the recording mode while recording or during recording pause.
- In the event of a power failure, the programme you are recording may be erased.
- You cannot watch a PAY-TV/Canal Plus programme while recording another PAY-TV/Canal Plus programme.
- To use the TV Direct Rec function, you must first set the recorder's clock correctly.

Checking the disc status while recording

You can check recording information, such as recording time or disc type.

Press DISPLAY twice during recording.

The recording information appears.



- 1 Disc type/format
- 2 Recording status
- 3 Recording mode
- 4 Recording time

Press DISPLAY to turn off the display.

3. Playing the Recorded Programme (Title List)



To play a recorded title, select the title from the Title List.

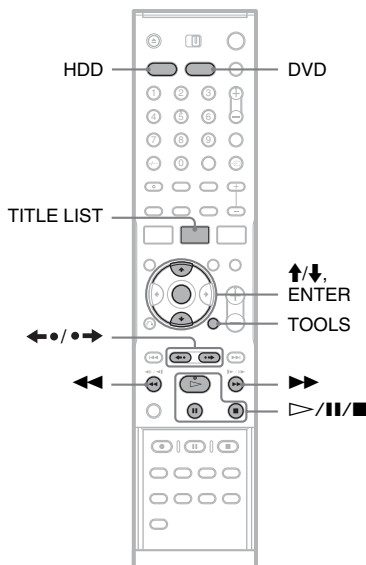

1 Press HDD or DVD.

If you select DVD, insert a DVD (see “Inserting a disc” on page 36). Playback starts automatically depending on the disc.

2 Press TITLE LIST.

To show the extended Title List, press TOOLS, select “Display List,” and press ENTER.

Title List with Thumbnail Images (Example: DVD-RW in VR mode)

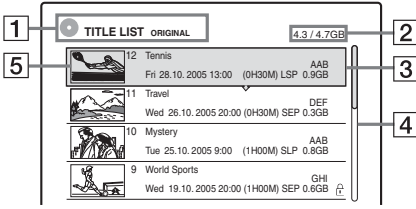

Extended Title List

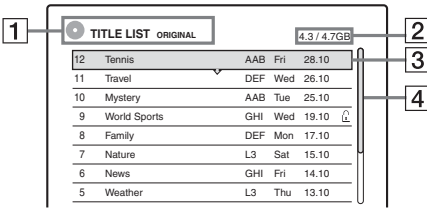

3 Select a title, and press ENTER.

The sub-menu appears.

The sub-menu displays options applicable only to the selected item. The displayed options differ depending on the model, situation, and disc type.

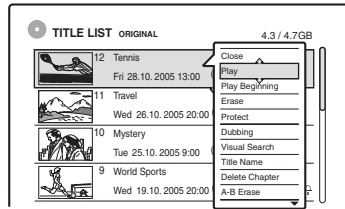

Sub-menu

4 Select "Play," and press ENTER.

Playback starts from the selected title.

- 1** Disc type:
Displays a media type, HDD or DVD.
Also displays the title type (original or Playlist) for HDD or DVD-RWs (VR mode).
- 2** Disc space (remainder/total)
- 3** Title information:
Displays the title number, title name, and recording date. Title size is shown in the thumbnail Title List.
● (red): Indicates that the title is currently being recorded.
●●: Indicates that the title is currently being dubbed.
🔒: Indicates the protected title.
"NEW" (or N): Indicates that the title is newly recorded (not played back) (HDD only).
🔄: Indicates that the Update function is set (HDD only) (page 50).
COPY: Indicates titles containing "Copy-Once" copy protection signals (HDD only) (page 80).
- 4** Scroll bar:
Appears when not all titles fit on the list. To view the hidden titles, press ↑/↓.
- 5** Title's thumbnail picture
Still images for each title are displayed.

To stop playback

Press ■.

To scroll the list display by page (Page mode)

Press ◀●/●▶ while the list display is turned on. Each time you press ◀●/●▶, the entire Title List changes to the next/previous page of titles.

About the Title List for HDD/DVD-RWs (VR mode)

You can switch the Title List to show original or Playlist.

While the Title List menu is turned on, press TOOLS to select either "Original" or "Playlist," and press ENTER.

For details, see "Edit options for the HDD and DVD-RWs (VR mode)" on page 71.

To change the title order (Sort)

While the Title List menu is turned on, press TOOLS to select "Sort Titles." Press ↑/↓ to select the item, and press ENTER.

Order	Sorted
By Date	in order of when the titles were recorded. The title that is recorded most recently is listed at the top.
By Title	in alphabetical order.
By Number	in order of recorded title number.

Order	Sorted
Unseen Title (HDD only)	in order of when the titles were recorded. The title that is recorded most recently and not played back is listed at the top. Playlist titles are not displayed.

To change a title thumbnail picture (Thumbnail) (HDD/DVD-RW in VR mode only)

You can select a favourite scene for the thumbnail picture shown in the Title List menu.

- 1 Press TITLE LIST in stop mode.
- 2 Select a title whose thumbnail picture you want to change, and press ENTER. The sub-menu appears.
- 3 Select "Set Thumbnail," and press ENTER. The selected title starts to play in the background.
- 4 While watching the playback picture, press \triangleright , \parallel , or $\triangleleft/\triangleright$ to select the scene you want to set for a thumbnail picture, and press ENTER. The display asks for confirmation.
- 5 Select "OK," and press ENTER. The scene is set for the title's thumbnail picture.

To turn off the Title List

Press TITLE LIST.

Hints

- After recording, the first scene of the recording (the title) is automatically set as the thumbnail picture.
- You can select "TITLE LIST" from the System Menu.

Notes

- The title names may not appear for DVDs created on other DVD recorders.
- Letters that cannot be displayed are replaced with "*."
- It may take a few seconds for the thumbnail pictures to be displayed.
- After editing, the title thumbnail picture may change to the first scene of the recording (title).
- After dubbing, the title thumbnail picture set on the source recording is cancelled.

4. Displaying the Playing Time and Play Information



You can check the playing time and remaining time of the current title, chapter, or track. Also, you can check the disc name recorded on the DVD/CD.

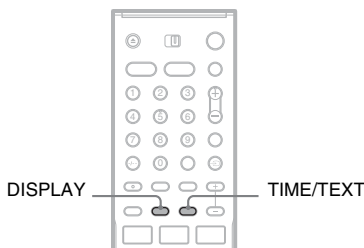

Press DISPLAY repeatedly.

Each time you press the button, the display changes as follows:



Display 1 → Display 2 → Display off

The displays differ depending on the disc type or playing status.

◆ Display 1

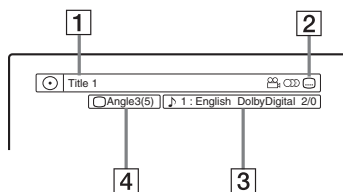
Example: When playing a DVD VIDEO



- 1 Title number/name
(Shows either track number, track name, scene number, or file name for CDs, VIDEO CDs, or DATA CDs.)
- 2 Available functions for DVD VIDEOS
( angle/ audio/ subtitle, etc.), or playback data for DATA CDs

- 3 The currently selected function or audio setting (appears momentarily)

Example: Dolby Digital 5.1 ch

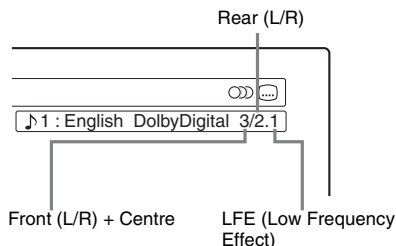

- 4 The current selected angle

◆ Display 2

Example: When playing a DVD-RW (VR mode)

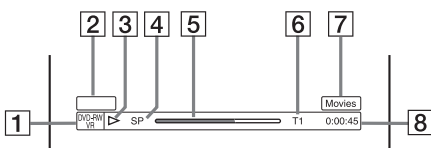

- 1 Disc type^{*1}/format (page 8)
- 2 Title type (only appears for Playlists) (page 71)
- 3 Play mode
- 4 Recording mode (page 48)
- 5 Playing status bar^{*2}
- 6 Title number (chapter number^{*3}) (page 66) (Shows either track number, scene number, album number^{*3}, or file number for CDs, VIDEO CDs, or DATA CDs.)
- 7 Album name appears for CDs with CD text, or DATA CDs when you press TIME/TEXT repeatedly.
- 8 Playing time (remaining time^{*3})

^{*1} Displays Super VIDEO CDs as “SVCD,” DATA CDs as “CD.”

^{*2} Does not appear with VIDEO CDs and DATA CDs.

^{*3} Displayed when you press TIME/TEXT repeatedly.

💡 Hint

When “Auto Display” is set to “On” (default) in “Options” setup (page 104), playback information automatically appears when the recorder is turned on, etc.

Note

Letters or symbols that cannot be displayed are replaced with “*.”

Checking the playing/remaining time

You can view the playing or remaining time information displayed on the TV screen and the front panel display.

Press TIME/TEXT repeatedly.

The displays differ depending on the disc type or playing status.

◆ Front panel display

Example: When playing a DVD

Playing time and number of current title



Remaining time of current title



Playing time and number of current chapter



Remaining time of current chapter



Example: When dubbing a DVD

Remaining time of dubbing in progress



Example: When playing a VIDEO CD

Playing time and number of current scene or track



Example: When playing a CD

Track playing time and current track/index number

Remaining time of current track

Playing time of disc

Remaining time of the disc

CD text (when available)

Example: When playing an MP3 audio track

Playing time and number of current track

Current album number

Example: When viewing a JPEG image

Current file number and total number of files in current album

Current album number and total number of albums

Notes

- The recorder can only display the first level of a CD's text, such as the disc name.
- Letters or symbols that cannot be displayed are replaced with "*."
- Displayed playing time of MP3 audio tracks may not be exact.

5. Changing the Name of a Recorded Programme

You can label a DVD, title, or programme by entering characters. You can enter up to 64 characters for a title or disc name, but the actual number of characters displayed in menus such as the Title List will vary. The steps below explain how to change the name of a recorded programme.

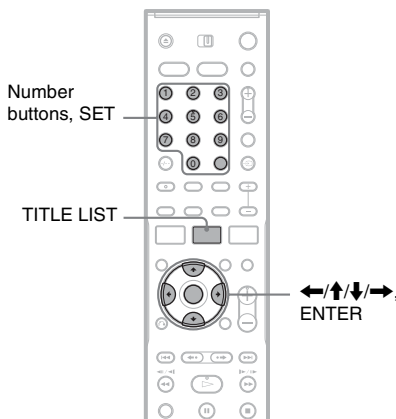

- 1 Press TITLE LIST.**
- 2 Select a title, and press ENTER.**
The sub-menu appears.
- 3 Select "Title Name," and press ENTER.**
The display for entering characters appears.
- 4 Press ←/↑/↓/→ to move the cursor to the right of the screen and select "A" (upper-case), "a" (lower-case), or "Symbol," and press ENTER.**
The characters of the selected type are displayed.

5 Press ←/↑/↓/→ to select the character you want to enter, and press ENTER.

The selected character appears at the top of the display.

Example: Input Title Name

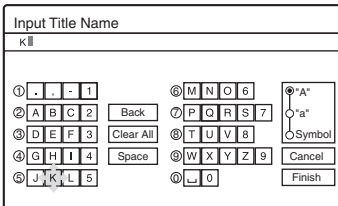

The type of characters will change according to the language you select in “Easy Setup.” Some languages allow you to enter an accent mark.

To enter a letter with an accent mark, select an accent followed by the letter.

Example: Select “ ` ” and then “a” to enter “à.”
To insert a space, select “Space.”

6 Repeat steps 4 and 5 to enter other characters.

Input row

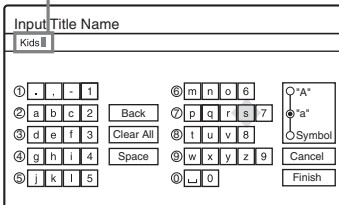

To erase a character, move the cursor to the right of the character at the input row. Select “Back” and press ENTER.

To insert a character, move the cursor to the right of the point where you want to insert the character. Select the character and press ENTER.

To erase all of the characters, select “Clear All” and press ENTER.

7 Select “Finish,” and press ENTER.

To cancel the setting, select “Cancel.”

To use the number buttons

You can also use the number buttons to enter characters.

1 In step 5 above, press a number button repeatedly to select a character.

Example:

Press the number 3 button once to enter “D.”

Press the number 3 button three times to enter “F.”

2 Press SET and select the next character.

3 Select “Finish” and press ENTER.

Hints

- You can erase all displayed characters by pressing and holding CLEAR for two seconds or more.
- You can switch between “A” (upper-case), “a” (lower-case), or “Symbol” even if you press INPUT SELECT.

6. Labelling and Protecting a Disc

You can apply options to the entire disc using the Disc Information display.

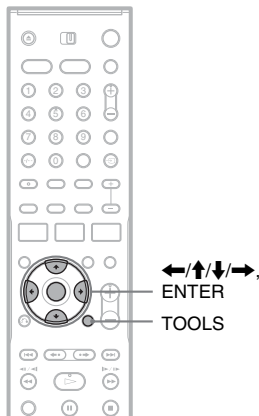

Labelling a disc

+RW -RWVR -RW Video +R -R

- 1 Insert a disc.**
See “Inserting a disc” on page 36.
- 2 Press TOOLS, select “Disc Info,” and press ENTER.**
Example: When the inserted disc is a DVD-RW (VR mode).

Disc Information	
DiscName	
Media	DVD-RW Format VR
Title no.	Original 3 / Playlist 2
Date	13.10.2005 - 28.10.2005 Off
Remainder	HQ : 0H30M HSP : 0H45M SP : 1H00M LSP : 1H15M LP : 1H30M EP : 2H00M SLP : 3H00M SEP : 4H00M 2.3 / 4.7GB

- 3 Select “Disc Name,” and press ENTER.**
Enter the disc name in the “Input Disc Name” display (page 43).

Note

You can enter up to 64 characters for a DVD’s disc name. The disc name may not appear when the disc is played on other DVD equipment.

Protecting a disc

-RWVR

- 1 Insert a disc.**
See “Inserting a disc” on page 36.
- 2 Press TOOLS, select “Disc Info,” and press ENTER.**

Disc Information	
DiscName	
Media	DVD-RW Format VR
Title no.	Original 3 / Playlist 2
Date	13.10.2005 - 28.10.2005 Off
Remainder	HQ : 0H30M HSP : 0H45M SP : 1H00M LSP : 1H15M LP : 1H30M EP : 2H00M SLP : 3H00M SEP : 4H00M 2.3 / 4.7GB

- 3 Select “Protect Disc,” and press ENTER.**
- 4 Select “Protect,” and press ENTER.**

To cancel the protection

Select “Don’t Protect” in step 4.

Hint

You can set protection for individual titles (page 72).

7. Playing the Disc on Other DVD Equipment (Finalize)

+RW **-RWVR** **-RWVideo** **+R** **-R**

Finalizing is necessary in order to play discs recorded with this recorder on other DVD equipment.

When you finalize a DVD+RW, DVD-RW (Video mode), DVD+R, or DVD-R, a DVD menu will be automatically created, which can be displayed on other DVD equipment.

Before finalizing, check the differences between the disc types in the table below.

Differences between the disc types

+RW Discs are automatically finalized when removed from the recorder. However, you may need to manually finalize a disc for certain DVD equipment, or if the recording time is short. You can edit or record on the disc even after finalizing.

-RWVR Finalizing is unnecessary when playing a disc on VR format compatible equipment. Even if your other DVD equipment is VR format compatible, you may need to finalize the disc, especially if the recording time is short. You can edit or record on the disc even after finalizing.

-RWVideo Finalizing is necessary in order to play on equipment other than this recorder. After finalizing, you cannot edit or record on the disc. If you want to record on it again, unfinalize or reformat the disc (page 36). However, if you reformat the disc, all recorded contents will be erased.

+R Finalizing is necessary in order to play on equipment other than this recorder.
-R After finalizing, you cannot further edit or record on the disc.

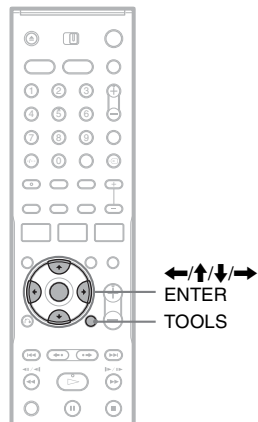

- 1 Insert a disc.**
See “Inserting a disc” on page 36.
- 2 Press TOOLS, select “Disc Info,” and press ENTER.**
The “Disc Information” display appears.
- 3 Select “Finalize,” and press ENTER.**
The display shows the approximate time required for finalizing and asks for confirmation.

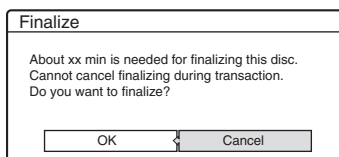

- 4 Select “OK,” and press ENTER.**
The recorder starts finalizing the disc.

Hint

You can check whether the disc has been finalized or not. If you cannot select “Finalize” in step 3 above, the disc has already been finalized.

Notes

- Depending on the condition of the disc, recording, or the DVD equipment, playback may not be possible even if the disc is finalized.
- The recorder may not be able to finalize a disc if it was recorded on another recorder.

Unfinalizing a disc

-RWVR **-RWVideo**

For DVD-RWs (Video mode)

To record or edit further, you can unfinalize DVD-RWs (Video mode) that have been finalized on this recorder. (Not possible if finalized on other DVD equipment.)

For DVD-RWs (VR mode)

When you try to record or edit a DVD-RW (VR mode) finalized on other DVD equipment, a message may appear indicating that the disc needs unfinalizing.

1 Insert a disc.

See “Inserting a disc” on page 36.

2 Press **TOOLS**, select “Disc Info,” and press **ENTER**.

The “Disc Information” display appears.

3 Select “Unfinalize,” and press **ENTER**.

Unfinalizing starts, which may take several minutes.

Timer Recording

Before Recording

Before you start recording...

- This recorder can record on various discs. Select the disc type according to your needs (page 8).
- Check that the disc has enough available space for the recording (page 36). For HDD, DVD+RWs, and DVD-RWs, you can free up disc space by erasing titles (page 75).
- Adjust the recording picture quality and picture size if necessary (page 54).

Hint

Timer recordings will be made regardless of whether or not the recorder is turned on. You can turn off the recorder without affecting the recording even after recording starts.

Note

To play a recorded disc on other DVD equipment, finalize the disc (page 46).

Recording mode

Like the SP or LP recording mode of VCRs, this recorder has eight different recording modes. Select a recording mode according to the time and picture quality you need. For example, if picture quality is your top priority, select the High Quality mode (HQ). If recording time is your priority, Super Extended Play mode (SEP) can be a possible choice. Note that recording times in the following table are approximate and actual time may differ. Note also that the maximum continuous recording time for a single title is eight hours. Contents beyond this time will not be recorded.

Press REC MODE repeatedly to switch the recording modes.

Recording mode	Recording time (hours)		
	HDD		DVD*
	DAR-RH1000	DAR-RH7000	
HQ (High quality)	33	53	1
HSP	↑ 51	81	1 hr. 30 min.
SP (Standard mode)	67	107	2
LSP	↓ 85	135	2 hr. 30 min.
LP	↓ 103	164	3
EP	↓ 137	217	4
SLP	↓ 204	325	6
SEP (Long duration)	269	428	8

* The recording time for DVD+R DL (Double Layer) discs is as follows:

HQ: 1 hour 48 minutes
HSP: 2 hours 42 minutes
SP: 3 hours 37 minutes
LSP: 4 hours 31 minutes
LP: 5 hours 25 minutes
EP: 7 hours 14 minutes
SLP: 10 hours 51 minutes
SEP: 14 hours 28 minutes

“HQ+” recording mode

“HQ+” records pictures in higher quality than HQ on the HDD. Set “HQ Setting” in “Features” setup to “HQ+” (page 100). Maximum recording time is 21 hours for DAR-RH1000, or 34 hours for DAR-RH7000. “HQ” appears in the display.

Note

Situations below may cause slight inaccuracies with the recording time.

- Recording a programme with poor reception, or a programme or video source of low picture quality.
- Recording on a disc that has already been edited.
- Recording only a still picture or just sound.

Recording stereo and bilingual programmes

The recorder automatically receives and records stereo and bilingual programmes based on the ZWEITON system or the NICAM system. The HDD and a DVD-RW (VR mode) can record both main and sub sounds. You can switch between main and sub when playing the disc. For the HDD, select the soundtrack before recording. Select “Main,” “Sub,” or “Main+Sub” in “HDD Bilingual Rec.” of “Options” setup (page 103).

A DVD+RW, DVD-RW (Video mode), DVD+R, or DVD-R can record only one soundtrack (main or sub) at a time. Select the soundtrack using the Setup Display before recording starts. Set “DVD Bilingual Rec.” to “Main” (default) or “Sub” in “Options” setup (page 103).

ZWEITON (German stereo) system

When a stereo based programme is received, “Stereo” appears.

When a bilingual ZWEITON based programme is received, “Main,” “Sub,” or “Main/Sub” appears.

NICAM system

When a stereo or bilingual NICAM based programme is received, “NICAM” appears in the front panel display.

To record a NICAM programme, be sure to set “Audio” of “Channel Setting” in “Settings” setup to “NICAM” (default). If the sound is not clear when listening to NICAM broadcasts, set “Audio” to “Standard” (see “Channel Setting” on page 90).

Hint

You can select the audio (main or sub) while recording bilingual programmes using the  (audio) button. This does not affect the recorded sound.

Unrecordable pictures

Pictures with copy protection cannot be recorded on this recorder.

When the recorder receives a copy guard signal, the recorder continues to record but only a blank, grey screen will be recorded.

Copy control signals	Recordable discs
Copy-Free	<div style="display: flex; justify-content: space-around; align-items: center;"> <div style="border: 1px solid black; padding: 2px;">HDD</div> <div style="border: 1px solid black; padding: 2px;">+RW</div> <div style="border: 1px solid black; padding: 2px;">-RWvR</div> </div> <div style="display: flex; justify-content: space-around; align-items: center; margin-top: 5px;"> <div style="border: 1px solid black; padding: 2px;">-RW_{Video}</div> <div style="border: 1px solid black; padding: 2px;">+R</div> <div style="border: 1px solid black; padding: 2px;">-R</div> </div>
Copy-Once	<div style="display: flex; justify-content: space-around; align-items: center;"> <div style="border: 1px solid black; padding: 2px;">HDD</div> </div> <div style="display: flex; justify-content: space-around; align-items: center; margin-top: 5px;"> <div style="border: 1px solid black; padding: 2px;">-RWvR</div> <div style="font-size: small;">(Ver.1.1 with CPRM*)</div> </div>
Copy-Never	None (a blank screen is recorded)

* The recorded disc can be played only on CPRM compatible equipment (page 8).

Timer Recording (Standard/Video Plus+)

HDD +RW -RWVR -RW_{Video} +R -R

You can set the timer for a total of 30 programmes (8 programmes when using the PDC/VPS function), up to one month in advance.

There are two methods to set the timer: the standard method or Video Plus+.

- Standard: Set the date, time, and programme position of the programme manually.
- Video Plus+: Enter the Plus Code number designated for each TV programme (page 52).

Setting the timer manually (Standard)

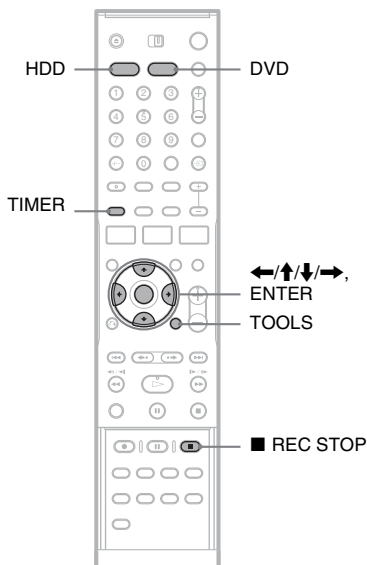

1 Press HDD or DVD, and press TIMER.

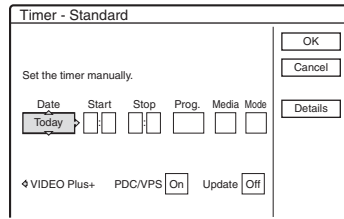

- If the “Timer – VIDEO Plus+” display appears, press ← to switch the display to “Standard”.

2 Select an item using ←/→ and adjust using ↑/↓.

“Date”: Sets the date.

The item changes as follows:

Today ↔ Tomorrow ↔ ↔ Thu
 28.10 (1 month later) ↔ Sun (every Sunday)
 ↔ ↔ Sat (every Saturday) ↔
 Mon-Fri (Monday to Friday) ↔ Mon-Sat
 (Monday to Saturday) ↔ Sun-Sat (Sunday to
 Saturday) ↔ Today

“Start”: Sets the start time.

“Stop”: Sets the stop time.

“Prog.”: Selects the programme position or input source.

“Media”: Selects the media, HDD or DVD.

“Mode”: Selects the recording mode (page 48).

- If you want to change the setting for the PDC/VPS or Update functions, select “Details” and press ENTER. Select an item using ←/→ and set using ↑/↓.

“PDC/VPS”: Sets the PDC/VPS function. See “About the PDC/VPS function” below.

“Update” (HDD only): Automatically records over a previously recorded programme set to be recorded daily or weekly.

To return to the Timer programming menu, select “Previous” and ENTER.

- If you make a mistake, select the item and change the setting.

3 Select “OK,” and press ENTER.

The Timer List (page 55) appears. The TIMER REC indicator lights up in the front panel and the recorder is ready to start recording.

Unlike a VCR, there is no need to turn off the recorder before the timer recording starts.

To stop recording during timer recording

Open the remote’s cover and press **REC STOP**. Note that it may take a few seconds for the recorder to stop recording.

About the PDC/VPS function

PDC/VPS signals are transmitted with TV programmes in some broadcast systems. These signals ensure that timer recordings are made regardless of any broadcast delays, early starts, or broadcast interruptions.

◆To use the PDC/VPS function

Set “PDC/VPS” to “On” in step 2 above. When you turn on this function, the recorder starts scanning the channel before the timer recording starts. If you are watching TV when scanning starts, a message will appear on the TV screen. If you want to watch TV, switch to your TV’s tuner or turn off the PDC/VPS channel scan function. Note that if you turn off the PDC/VPS channel scan function, the timer recording will not start.

◆To turn off the PDC/VPS channel scan

Press **TOOLS** and select “PDC/VPS Scan Off.” To ensure that the PDC/VPS function works properly, turn off the recorder before the timer recording starts. This will automatically turn on the PDC/VPS channel scan function while the recorder remains off.

Rec Mode Adjust

If there is not enough available disc space for the recording, the recorder automatically adjusts the recording mode to enable the entire programme to be recorded. This function is normally set to “On.”

- To cancel this function, press **TOOLS** while the Timer List is displayed. Select “Rec Mode Adjust” and press **ENTER**. Select “Off” and press **ENTER**.

If timer settings overlap

Overlapped timer settings are shown as follows.

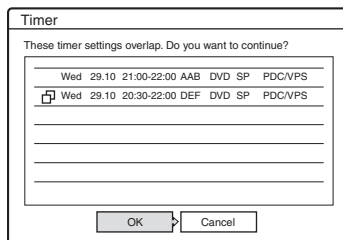

- To store the setting as shown, select “OK.” The programme that starts first has priority and the second programme starts recording only after the first programme has finished.
- To cancel the overlapped setting, select “Cancel.”

To confirm, change, or cancel timer recording

See “Checking/Changing/Cancelling Timer Settings (Timer List)” on page 55.

To extend recording time while recording

- 1 Press **TOOLS** during recording to select “Extend Rec,” and press **ENTER**.

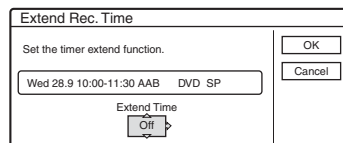

- 2 Press **↑/↓** to select the duration time. You can set the duration in increments of 10 minutes, for a maximum of 60 minutes.
- 3 Select “OK” and press **ENTER**.

One Touch Timer

If you use the SMARTLINK connection, you can easily display the timer programming menu. When the TV is turned on, press **TIMER**. The recorder automatically turns on and the TV’s input is set to the recorder. The Timer programming menu appears.

Hint

You can play the recorded programme by selecting the programme title in the Title List.

Notes

- If a message indicating that the disc is full appears on the screen, change the disc, or make available space for the recording (HDD/DVD+RW/DVD-RW only) (page 74).
- Check that the clock is correctly set before setting the timer recording. If not, the timer recording cannot be made.
To record a satellite programme, turn on the satellite tuner and select the satellite programme you want to record. Leave the satellite tuner turned on until the recorder finishes recording. If you connect equipment with a timer function, you can use the Synchro Rec function (page 57).
- Even if the timer is set for the same daily or weekly programme, the timer recording cannot be made if it overlaps with a programme that has priority. “” will appear next to the overlapped setting in the Timer List. Check the priority order of the settings.
- Even if the timer is set, timer recordings cannot be made while recording a programme that has priority.
- The Rec Mode Adjust function only works with a timer recording and the PDC/VPS function set to off. It does not function with Quick Timer or Synchro Rec. In addition, the Rec Mode Adjust function does not work when recording to the HDD while “Auto Title Erase” is set to “On.”
- The beginning of some recordings may not be made when using the PDC/VPS function.
- You cannot extend recording time when “PDC/VPS” is set to “On.”

Recording TV programmes using the Video Plus+ system

The Video Plus+ system is a feature that simplifies setting the timer. Just enter the Plus Code number listed in the TV programme guide. The date, time, and programme position of that programme are set automatically.

Check that the programme positions are correctly set in “Channel Setting” in “Settings” setup (page 90).

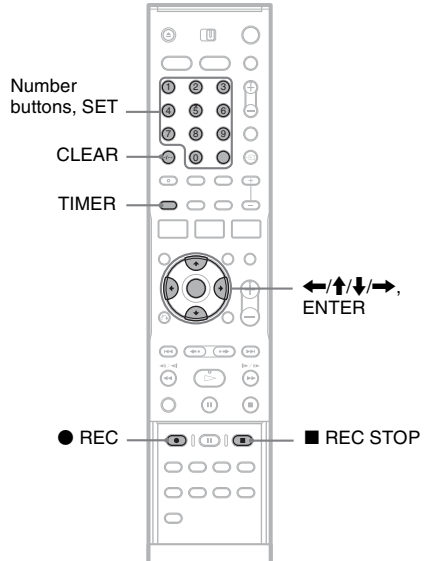

1 Press TIMER.

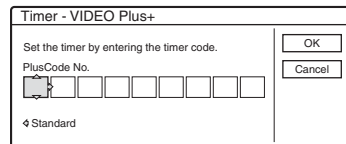

- If the “Timer – Standard” display appears, press  to switch the display to “VIDEO Plus+.”

2 Press the number buttons to enter a Plus Code number, and press SET.

- If you make a mistake, press CLEAR and re-enter the correct number.

3 Select “OK,” and press ENTER.

The settings for date, start and stop times, programme position, recording mode, etc., appear (page 51).

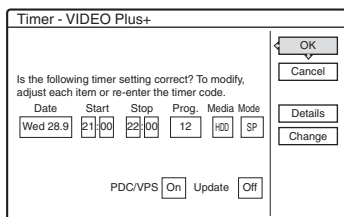

- If you want to change the setting, press ←/→ to select the item and press ↑/↓ to change the setting. For the PDC/VPS or Update functions, select “Details” and change the settings (page 51).
- To re-enter the Plus Code number, select “Change.”

4 Select “OK,” and press ENTER.

The TIMER REC indicator lights up on the front panel, and the recorder is ready to start recording.

To stop recording during timer recording

Open the remote’s cover and press ■ REC STOP. Note that it may take a few seconds for the recorder to stop recording.

If timer settings overlap

See page 51.

To extend recording time while recording

See page 51.

To confirm, change, or cancel timer recording

See “Checking/Changing/Cancelling Timer Settings (Timer List)” on page 55.

💡 Hint

The Rec Mode Adjust function also works with this timer method (page 51).

Using the Quick Timer function

You can set the recorder to record in 30-minute increments.

Press ● REC repeatedly to set the duration.

Each press advances the time in 30-minute increments. The maximum duration is six hours.

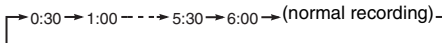

The time counter decreases minute by minute to 0:00, then the recorder stops recording (power does not turn off). Even if you turn off the recorder during recording, the recorder continues to record until the time counter runs out.

Note that the Quick Timer function does not work if “TV Direct Rec” is set to “On” in “Features” setup (page 98).

To cancel the Quick Timer

Press ● REC repeatedly until the counter appears in the front panel display. The recorder returns to normal recording mode.

Adjusting the recording picture quality and size

You can adjust the recording picture quality and picture size.

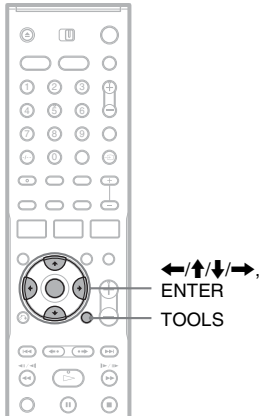

- 1 Before recording starts, press **TOOLS**, select “Rec Settings,” and press **ENTER**.

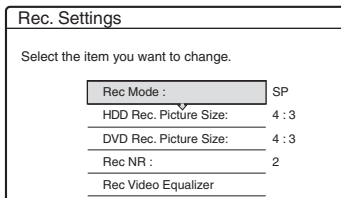

- 2 Select the item you want to adjust, and press **ENTER**.

The adjustment display appears.

Example: Rec NR



“Rec Mode”: Selects the recording mode for the desired recording time and picture quality. For more information, see “Recording mode” on page 48.

“HDD Rec. Picture Size”/“DVD Rec. Picture Size”: Sets the picture size of the programme to be recorded.

- 4:3 (default): Sets the picture size to 4:3.
- 16:9: Sets the picture size to 16:9 (wide mode).
- Auto (HDD only): Automatically selects the correct picture size.

“DVD Rec. Picture Size”: Works with DVD-Rs and DVD-RWs (Video mode) when the recording mode is set to HQ, HSP, or SP. For all other recording modes, the screen size is fixed at “4:3.”

For DVD-RWs (VR mode), the actual picture size is recorded regardless of the setting. For example, if a 16:9 size picture is received, the disc records the picture as 16:9 even if “DVD Rec. Picture Size” is set to “4:3.”

For DVD+RWs/DVD+Rs, the screen size is fixed at “4:3.”

“Rec NR” (noise reduction): Reduces noise contained in the video signal.

“Rec Video Equalizer”: Adjusts the picture in greater detail. Press **↑/↓** to select the item you want to adjust, then press **ENTER**.

- Contrast: Changes the contrast.
- Brightness: Changes the overall brightness.
- Colour: Deepens or lightens the colours.

- 3 Adjust the setting using **←/↑/↓/→**, and press **ENTER**.

The default setting is underlined.

“Rec NR”: (weak) Off 1 2 3 (strong)

“Rec Video Equalizer”:

- Contrast: (weak) -3 ~ 0 ~ 3 (strong)
- Brightness: (dark) -3 ~ 0 ~ 3 (bright)
- Colour: (light) -3 ~ 0 ~ 3 (deep)

Repeat steps 2 and 3 to adjust any other items.

Notes

- If one programme contains two picture sizes, the selected size is recorded. However, if the 16:9 signal cannot be recorded as 16:9, it is recorded as 4:3.
- When playing a 16:9 size picture recorded as 4:3, The image is fixed to 4:3 letter box regardless of the setting in “TV Type” of “Video” setup (page 95).
- Remnants of images may appear on your screen when using “Rec NR.”
- “Rec Video Equalizer” does not work with RGB signals.

Creating chapters in a title

The recorder can automatically divide a recording (a title) into chapters by inserting chapter marks during recording. To disable this function, set “Auto Chapter” in “Features” setup to “Off” (page 98).

When recording on the HDD or a DVD-RW (VR mode)

The recorder detects changes in the picture and sound and automatically inserts chapter marks. You can also insert and erase chapter marks manually (page 75).

When recording on other recordable discs

Chapter marks are inserted at approximately 6-minute intervals during recording.

Note

When dubbing (page 79), the chapter marks in the dubbing source are not retained in the dubbed title.

Checking/Changing/ Cancelling Timer Settings (Timer List)

HDD +RW -RWVR -RWVideo +R -R

You can check, change, or cancel timer settings using the Timer List.

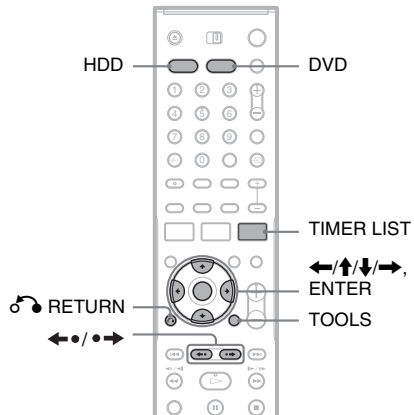

- 1 Press **HDD** or **DVD**, and press **TIMER LIST**. The Timer List appears.

TIMER LIST		10:30
●	Mon-Sat 22:00-22:15 AAB SP	
○	Fri 29.10 20:30-21:30 DEF SP PDC VPS	
○	Fri 29.10 21:00-22:00 GHI SLP PDC VPS	
○	Sat 30.10 16:00-17:00 DEF SLP	

Timer information displays the recording date, time, recording mode, etc.

□: Indicates that the setting is overlapped by another setting.

● (green): Indicates the setting can be recorded.

● (red): Indicates the setting currently being recorded.

○ (grey): Indicates that the setting cannot be recorded in the selected recording mode.

● (HDD): Indicates the setting being recorded on the HDD.

● (DVD): Indicates the setting being recorded on a DVD.

: Indicates the setting that the Update function is set for.

When all of the timer settings do not fit on the list, scroll bar appears.

To view the hidden timer settings, press **↑/↓**.

2 Select the timer setting you want to check/change/cancel, and press ENTER.

The sub-menu appears.

3 Select one of the options, and press ENTER.

“Modify”: Changes the timer setting.

Select an item using **←/→** and adjust using **↑/↓**. For the PDC/VPS or Update functions, select “Details” and change the settings (page 51). Select “OK,” and press ENTER.

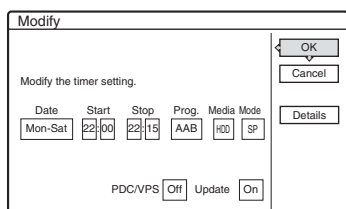

“Erase”: Erases the timer setting. Select “OK,” and press ENTER.

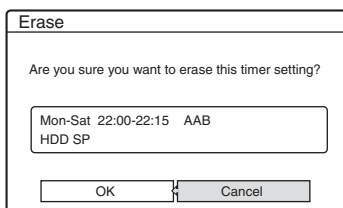

“Check Overlap”: Checks for overlapped settings.

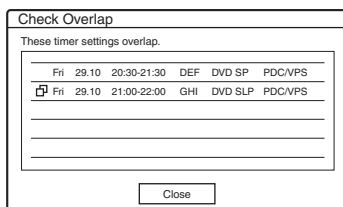

Check Overlap						
These timer settings overlap.						
	Fri	29.10	20:30-21:30	DEF	DVD SP	PDC/VPS
<input checked="" type="checkbox"/>	Fri	29.10	21:00-22:00	GHI	DVD SLP	PDC/VPS

Select “Close” to return to the Timer List.

To change or cancel the setting, repeat steps 2 and 3 above.

When timer settings overlap

The programme that starts first has priority and the second programme starts recording only after the first programme has finished.

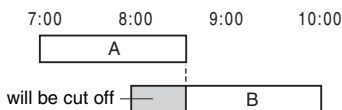

◆When recordings start at the same time

The programme that is set last has priority. In this example, timer setting B is set after A, so the first part of timer setting A will not be recorded.

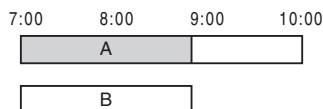

◆When the end time of one recording and the start time of another are the same

After finishing the previous recording, the other recording may be delayed.

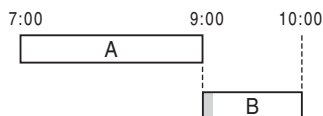

To scroll the list display by page (Page mode)

Press **←•/•→** while the list display is turned on. Each time you press **←•/•→**, the entire Timer List changes to the next/previous page of timer settings.

To turn off the Timer List

Press **TIMER LIST** or **RETURN**.

Hint

While recording, you cannot modify the timer setting for the current recording, but you can extend the recording duration of the recording time (page 51).

Notes

- When “PDC/VPS” is set to “On” for one or more timer recordings, the start times may change in the event of a broadcast delay or early start.
- Even if the timer is set, timer recordings cannot be made while recording a programme that has priority.
- Even if the timer is set for the same daily or weekly programme, the timer recording cannot be made if it overlaps with a programme that has priority. “” will appear next to the overlapped setting in the Timer List. Check the priority order of the settings.

Automatically erasing old titles (Auto Title Erase)

HDD

If there is not enough space for a timer recording, the recorder automatically erases old titles recorded on the HDD, starting with the oldest. Protected titles are not erased.

- 1 Press TIMER LIST.**
The Timer List appears.
- 2 Press TOOLS, select “Auto Title Erase,” and press ENTER.**
- 3 Select “On,” and press ENTER.**
The default setting is “Off.”

Recording From Connected Equipment

HDD +RW -RWvR -RWVideo +R -R

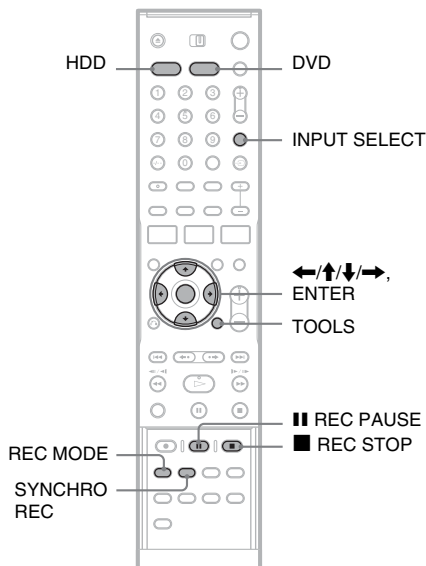

Recording from connected equipment with a timer (Synchro Rec)

You can set the recorder to automatically record programmes from connected equipment that has a timer function (such as a satellite tuner). Connect the equipment to the LINE 3/DECODER jack of the recorder (page 31).

When the connected equipment turns on, the recorder starts recording a programme from the LINE 3/DECODER jack.

- 1 Before recording, select HDD or DVD.**
If you select DVD, insert a recordable DVD (see “Inserting a disc” on page 36).
- 2 Set “Synchro Rec” in “Features” setup to “Record to HDD” or “Record to DVD” (page 100).**

3 Press **INPUT SELECT** repeatedly to select “L3.”

4 Select the line input audio when recording a bilingual programme on the HDD or DVD-RWs (VR mode).

Press **TOOLS**, select “Line Audio Input,” and press **ENTER**. Then select “Bilingual,” and press **ENTER**.

For details about bilingual recording, see page 49.

5 Press **REC MODE** repeatedly to select a recording mode.

For details about the recording mode, see page 48.

6 Set the timer on the connected equipment to the time of the programme you want to record, and turn it off.

7 Press **SYNCHRO REC**.

The **SYNCHRO REC** indicator lights up on the front panel. The recorder is ready to start Synchro-Recording.

The recorder automatically starts recording when it receives an input signal from the connected equipment. The recorder stops recording when the connected equipment turns off.

To stop recording

Press **REC STOP** or **SYNCHRO REC**.

To cancel Synchro Rec

Press **SYNCHRO REC**.

The **SYNCHRO REC** indicator on the recorder turns off.

Notes

- The recorder starts recording only after detecting the video signal from the connected equipment. The beginning of the programme may not be recorded regardless of whether or not the recorder’s power is on or off.
- During Synchro-Recording, other operations such as normal recording cannot be done.
- To use the connected equipment while the recorder is standing by for Synchro-Recording, cancel Synchro-Recording by pressing **SYNCHRO REC**. Be sure to turn off the connected equipment and press **SYNCHRO REC** to reset Synchro-Recording before the timer recording starts.
- The Synchro Rec function does not work when “Line3 Input” of “Scart Setting” in “Video” setup is set to “Decoder” (page 96).
- The Synchro Rec function does not work with some tuners. For details, see the tuner’s operating instructions.
- While the recorder is standing by for Synchro-Recording, the Auto Clock Set function (page 94) does not work.
- To use the Synchro Rec function, you must first set the recorder’s clock correctly.

If a timer setting of Synchro-Recording and another timer recording overlap

Regardless of whether or not the programme is a Synchro Rec programme, the programme that starts first has priority and the second programme starts recording only after the first programme has finished.

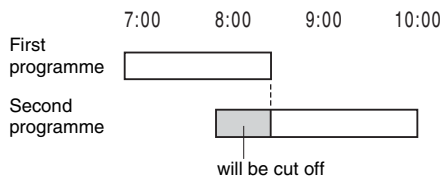

Recording from connected equipment without a timer

You can record from a connected VCR or similar device. For connection details, see “Connecting a VCR or similar device” on page 29.

1 Press HDD or DVD.

If you select DVD, insert a recordable DVD (see “Inserting a disc” on page 36).

2 Press INPUT SELECT to select an input source according to the connection you made.

The front panel display changes as follows:

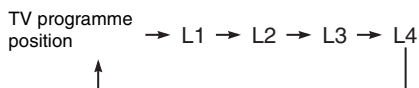

3 Select the line input audio when recording a bilingual programme on the HDD or DVD-RWs (VR mode).

Press TOOLS, select “Line Audio Input,” and press ENTER. Then select “Bilingual,” and press ENTER.

For details about bilingual recording, see page 49.

4 Press REC MODE repeatedly to select a recording mode.

For details about the recording mode, see page 48.

5 Press ■ REC PAUSE to set this recorder to record pause.

6 Insert the source tape into the connected equipment and set to playback pause.

7 At the same time, press ■ REC PAUSE on this recorder and the pause or play button on the connected equipment.

Recording starts.

To stop recording, press ■ REC STOP on this recorder.

Hint

You can adjust the settings for the recording picture before recording. See “Adjusting the recording picture quality and size” on page 54.

Notes

- When recording a video game image, the screen may not be clear.
- Any programme that contains a Copy-Never copy guard signal cannot be recorded. The recorder continues to record, but a blank screen will be recorded.

Playback

Playing

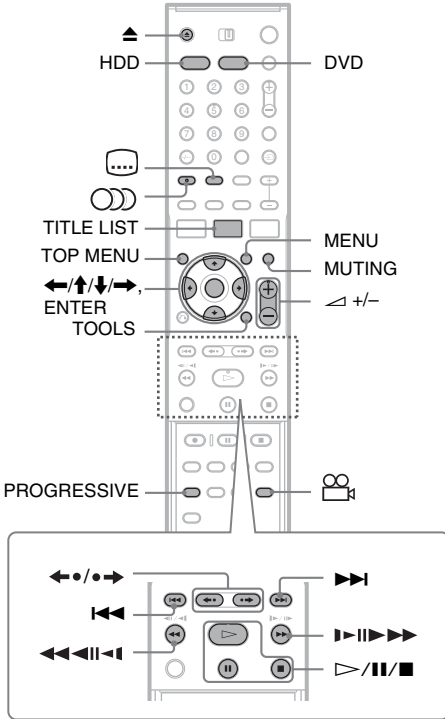

1 Press HDD or DVD.

- If you select DVD, insert a disc (see “Inserting a disc” on page 36).
- If you insert a DVD VIDEO, VIDEO CD, or CD, press . Playback starts.

2 Press TITLE LIST.

For details about the Title List, see “3. Playing the Recorded Programme (Title List)” on page 39.

Example: DVD-RW (VR mode)

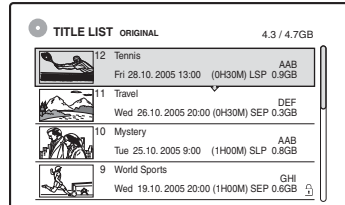

3 Select the title, and press ENTER.

The sub-menu appears.

4 Select “Play,” and press ENTER.

Playback starts from the selected title.

To use the DVD’s Menu

When you play a DVD VIDEO, or a finalized DVD+RW, DVD-RW (Video mode), DVD+R, or DVD-R, you can display the disc’s menu by pressing TOP MENU or MENU.

To play VIDEO CDs with PBC functions

PBC (Playback Control) allows you to play VIDEO CDs interactively using the menu on your TV screen.

When you start playing a VIDEO CD with PBC functions, the menu appears.

Select an item using the number buttons and press ENTER. Then, follow the instructions in the menu (press when “Press SELECT” appears).

The PBC function of Super VIDEO CDs does not work with this recorder. Super VIDEO CDs are played in continuous play mode only.

To stop playback

Press .

To playback quickly with sound (Scan Audio)

When you press during playback of a title recorded in the HDD, you can play quickly with dialogue or sound (“x1.5” appears).

No sound is output when you press two or more times to change search speed.

To resume playback from the point where you stopped (Resume Play)

When you press \triangleright again after you stop playback, the recorder resumes playback from the point where you pressed \blacksquare .

To start from the beginning, press TOOLS, select “Play Beginning,” and press ENTER. Playback starts from the beginning of the title/track/scene.

The point where you stopped playing is cleared when:

- you open the disc tray (except for HDD).
- you play another title (except for HDD).
- you switch the Title List menu to Original or Playlist (DVD-RW in VR mode only).
- you edit the title after stopping playback.
- you change the settings on the recorder.
- you turn off the recorder (VIDEO CD/CD/DATA CD only).
- you make a recording (except for HDD/DVD-RWs in VR mode).
- you switch between JPEG and MP3.

Note

You cannot resume playback during TV Pause.

To play restricted DVDs (Parental Control)

If you play a restricted DVD, the message “Do you want temporarily change parental control to *?” appears on your TV screen.

- 1 Select “OK” and press ENTER.
The display for entering your password appears.
- 2 Enter your four-digit password using the number buttons.
- 3 Press ENTER to select “OK.”
The recorder starts playback.

- To register or change the password, see “Parental Control (DVD VIDEO only)” on page 99.

To lock the disc tray (Child Lock)

You can lock the disc tray to prevent children from ejecting the disc.

With the recorder turned on, hold down \blacksquare until “LOCKED” appears in the front panel display. The \blacktriangle (open/close) button does not work while the Child Lock is set.

- To unlock the disc tray, hold down \blacksquare until “UNLOCKED” appears in the front panel display when the recorder is turned on.

One Touch Play

If you use the SMARTLINK connection, you can easily start playing.

Press \triangleright . The recorder and your TV automatically turn on and the TV’s input is switched to the recorder. Playback starts automatically.

One Touch Menu

If you use the SMARTLINK connection, you can easily display the Title List.









Press TITLE LIST. The recorder and your TV automatically turn on and the TV’s input is switched to the recorder. The Title List appears.

Hints

- You can also use the \triangleright button in step 3 (page 60) to start playback.
- Even if you select “Factory Setup” in “Options” setup (page 104), the Child Lock remains set.

Playback options

You can check the location of the buttons below on page 60.

Button	Operation								
 (audio) HDD -RWVR DVD VCD CD	Selects one of the audio tracks recorded on the disc when pressed repeatedly. DVD : Selects the language. HDD -RWVR : Selects the main or sub sound. VCD CD : Selects stereo or monaural audio tracks.								
 (subtitle) DVD	Selects a subtitle language when pressed repeatedly.								
 (angle) DVD	Selects an angle when pressed repeatedly. If various angles (multi-angles) for a scene are recorded on the disc, “  ” appears in the front panel display.								
MUTING	Mutes the sound from the speaker system. “MUTING ON” appears in the front panel display. To cancel, press the button again or press \triangleleft +. Note that the sound from your TV or the connected equipment cannot be muted.								
PROGRESSIVE HDD +RW -RWVR -RWVideo +R -R DVD VCD	Switches the type of video output signal to interlace or progressive format (page 26).								
 (instant replay/ instant advance) HDD +RW -RWVR -RWVideo +R -R DVD	Replays a scene/briefly fast forwards the scene.								
 (previous)/  (next)	Goes to the beginning of the previous or next title/chapter/scene/track. For the HDD, you cannot go to the beginning of the previous or next title.								
 (fast reverse/fast forward)	Fast reverses/fast forwards the disc when pressed during playback. Search speed changes as follows: <div style="text-align: center; margin: 10px 0;"> <table style="margin: auto;"> <tr> <td style="text-align: center;">fast reverse</td> <td style="text-align: center;">fast forward</td> </tr> <tr> <td style="text-align: center;">$\triangleleft\triangleleft 1 \triangleleft$</td> <td style="text-align: center;">$\rightarrow 1 \triangleright\triangleright^{*1}$</td> </tr> <tr> <td style="text-align: center;">$\triangleleft\triangleleft 2 \triangleleft\triangleleft$</td> <td style="text-align: center;">$\rightarrow\rightarrow 2 \triangleright\triangleright\triangleright$</td> </tr> <tr> <td style="text-align: center;">$\triangleleft\triangleleft 3^{*2} \triangleleft\triangleleft\triangleleft$</td> <td style="text-align: center;">$\rightarrow\rightarrow\rightarrow 3 \triangleright\triangleright\triangleright\triangleright^{*2}$</td> </tr> </table> </div> When you press and hold the button, fast forward/fast reverse continues at the selected speed until you release the button. <p>^{*1} When you press $\triangleright\triangleright$ once during playback of a title recorded in the HDD, you can play quickly with sound (“x1.5” appears).</p> <p>^{*2} $\triangleleft\triangleleft 3$ and $3 \triangleright\triangleright\triangleright$ are only available for the HDD and DVDs.</p>	fast reverse	fast forward	$\triangleleft\triangleleft 1 \triangleleft$	$\rightarrow 1 \triangleright\triangleright^{*1}$	$\triangleleft\triangleleft 2 \triangleleft\triangleleft$	$\rightarrow\rightarrow 2 \triangleright\triangleright\triangleright$	$\triangleleft\triangleleft 3^{*2} \triangleleft\triangleleft\triangleleft$	$\rightarrow\rightarrow\rightarrow 3 \triangleright\triangleright\triangleright\triangleright^{*2}$
fast reverse	fast forward								
$\triangleleft\triangleleft 1 \triangleleft$	$\rightarrow 1 \triangleright\triangleright^{*1}$								
$\triangleleft\triangleleft 2 \triangleleft\triangleleft$	$\rightarrow\rightarrow 2 \triangleright\triangleright\triangleright$								
$\triangleleft\triangleleft 3^{*2} \triangleleft\triangleleft\triangleleft$	$\rightarrow\rightarrow\rightarrow 3 \triangleright\triangleright\triangleright\triangleright^{*2}$								
 (slow, freeze frame)	Plays in slow motion when pressed for more than one second in pause mode. Plays one frame at a time when pressed briefly in pause mode.								
HDD +RW -RWVR -RWVideo +R -R DVD VCD *	* Playback direction only								
II (pause)	Pauses playback.								

To resume normal playback

Press \blacktriangleright .

Notes

- If the playback signal does not contain a signal for the rear speakers, surround effects will be difficult to hear. In addition, surround effects may also be difficult to hear depending on the title being played and the environment where the recorder is being used.
- If you play MPEG Audio soundtracks, the system outputs PCM (stereo) signals.
- Angles and subtitles of titles recorded on this recorder cannot be changed.

Notes on playing DTS soundtracks on a CD

- You can hear the DTS sound from this speaker system only. The LINE jacks on the recorder do not output the audio signals.
- Set the sound to “Stereo” using the $\odot\odot$ (audio) button (page 62).
- “CD Priority” in “Audio” setup must be set to “Auto” (page 98), or noise will result.

Note on playing DVDs with a DTS soundtrack

DTS audio signals are output only through the speaker system.

Adjusting the picture quality



1 Press **TOOLS** during playback to select “Video Settings,” and press **ENTER**.

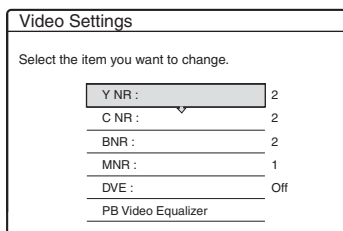

2 Select an item, and press **ENTER**.

The adjustment display appears.

“Y NR” (luminance noise reduction):

Reduces noise contained in the luminance element of the video signal.

“C NR” (chroma noise reduction): Reduces noise contained in the colour element of the video signal.

“BNR” (block noise reduction): Reduces “block noise” or mosaic-like patterns in the picture.

“MNR” (mosquito noise reduction): Reduces the faint noise appearing around the outlines of the images. The noise reduction effects are automatically adjusted within each setting range according to the video bit rate and other factors.

“DVE” (digital video enhancer): Sharpens the outlines of the images.

“PB Video Equalizer” (Playback video equalizer): Adjusts the picture in greater detail. Select an item and press **ENTER**.

- Contrast: Changes the contrast.
- Brightness: Changes the overall brightness.
- Colour: Deepens or lightens the colours.
- Hue: Changes the colour balance.

3 Press \leftarrow/\rightarrow to adjust the setting, and press **ENTER**.

The default settings are underlined.

“Y NR”: (weak) Off 1 2 3 (strong)

“C NR”: (weak) Off 1 2 3 (strong)

“BNR”: (weak) Off 1 2 3 (strong)

“MNR”: (weak) Off 1 2 3 (strong)

“DVE”*: (weak) Off 1 2 3 (strong)

“PB Video Equalizer”:

• Contrast: (weak) -3 ~ 0 ~ 3 (strong)

• Brightness: (dark) -3 ~ 0 ~ 3 (bright)

• Colour: (light) -3 ~ 0 ~ 3 (deep)

• Hue: (red) -3 ~ 0 ~ 3 (green)

Repeat steps 2 and 3 to adjust any other items.

* “1” softens the outlines of the images.

“2” enhances the outlines and “3” enhances them more than “2.”

Notes

- If the outlines of the images on your screen become blurred, set “BNR” and/or “MNR” to “Off.”
- Depending on the disc or the scene being played, the above Y NR, C NR, BNR, MNR effects may be hard to discern. These functions may not work with certain screen sizes.
- When using the DVE function, noise found in the title may become more apparent. In this case, it is recommended that you use the BNR function with the DVE function. If the condition still does not improve, set the DVE level to “1” or “Off.”

Adjusting the delay between the picture and sound (A/V SYNC)

HDD **+RW** **-RWVR** **-RWVideo** **+R** **-R**
DVD **VCD** **CD** **DATA CD**

If picture and sound do not match, you can adjust the delay between them.

1 Press **TOOLS** during playback to select “Audio Setting,” and press **ENTER**.

2 Press **ENTER**.

When the video is delayed, the function delays the audio for synchronization with the video (0 to 120 milliseconds). The higher the number, the longer the audio delay. When dubbing to a VCR or other video recording equipment, be sure to return this setting to 0 ms (default).

3 Press **←/→** to adjust the delay, and press **ENTER**.

Pausing a TV Broadcast (TV Pause)

You can pause a current TV broadcast and continue watching the programme at a later time. This is useful when you receive an unexpected phone call or visitor while watching TV.

1 While viewing a TV broadcast with this recorder, press **II**.

The picture pauses. You can pause the picture for up to three hours.

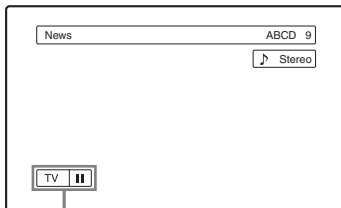

TV pause

2 Press **II** or **▷** again to resume watching the programme.

Notes

- Paused titles are not saved to the HDD.
- This function is cancelled when:
 - **■** (stop) is pressed.
 - **PROG +/-** is pressed.
 - **DVD** is pressed.
 - **▲** (open/close) is pressed.
 - **TITLE LIST** is pressed.
 - **INPUT SELECT** is pressed.
 - the recorder is turned off.
 - a timer recording or Synchro Recording is started.
 - the PDC/VPS function is “On” and channel scan is started.
- It may take a few seconds to resume playback of the paused programme.
- Even if you fast forward the recorded programme, there will always be a time difference of about one minute or more between the recorded programme and the current TV broadcast.

Playing back from the beginning of the programme you are currently recording (Chasing Playback)

HDD **-RWVR**

“Chasing Playback” allows you to view the recorded part of a programme while the recording is being made. You do not need to wait until the recording finishes.

Press **TOOLS** while recording to select “Chasing Playback,” and press **ENTER**.

Playback starts from the beginning of the programme you are recording.

When you fast forward to the point that you are recording, Chasing Playback returns to normal playback.

Notes

- For DVD-RWs (VR mode), this function does not work when recording:
 - on a 1x-speed DVD-RW.
 - in the HQ or HSP recording mode.
- The DVD’s picture on your TV screen freezes for a few seconds when you fast forward, fast reverse, instant replay, instant advance the recording.
- Chasing playback is possible after one or more minutes of recording.
- Even if you fast forward the recorded programme, there will always be a time difference of about one minute or more between the recorded programme and the current TV broadcast.

Playing a previous recording while making another (Simultaneous Rec and Play)



“Simultaneous Rec and Play” allows you to view a previously recorded programme while recording another programme. Playback continues even if a timer recording starts. Use this function as follows:

- While recording to the HDD:
Play another title on the HDD.
Play a previously recorded programme on a DVD by pressing DVD.
- While recording to a DVD:
Play a previously recorded programme on the HDD by pressing HDD.
- While recording to a DVD-RW (VR mode)^{*1}:
Play another title on the same DVD-RW (VR mode) disc.^{*2}

^{*1} Simultaneous Rec and Play function does not work when you record:

- on a 1x-speed DVD-RW.
- in the HQ or HSP recording mode.

^{*2} Picture noise may appear depending upon the condition of the recording, or when playing a title recorded in the HQ or HSP recording mode. The picture freezes for a few seconds when you use fast forward/fast reverse or instant replay/instant advance.

You can also play a DVD VIDEO, VIDEO CD, Super VIDEO CD, CD, or DATA CD while recording on the HDD.

Example: Play another title on the HDD while recording to the HDD.

- 1** While recording, press TITLE LIST to display the HDD Title List.
- 2** Select the title you want to play, and press ENTER.
- 3** Select “Play” from the sub-menu, and press ENTER.
Playback starts from the selected title.

Example: Play a DVD while recording to the HDD.

- 1** While recording, press DVD and insert the DVD into the recorder.
- 2** Press TITLE LIST to display the DVD Title List.
- 3** Select the title you want to play, and press ENTER.
- 4** Select “Play” from the sub-menu, and press ENTER.
Playback starts from the selected title.

Note

You cannot play a DVD or VIDEO CD recorded in the NTSC colour system while recording on the HDD. When playing a VIDEO CD, be sure to set “Colour System” to “PAL” (page 100).

Searching for a Title/ Chapter/Track, etc.

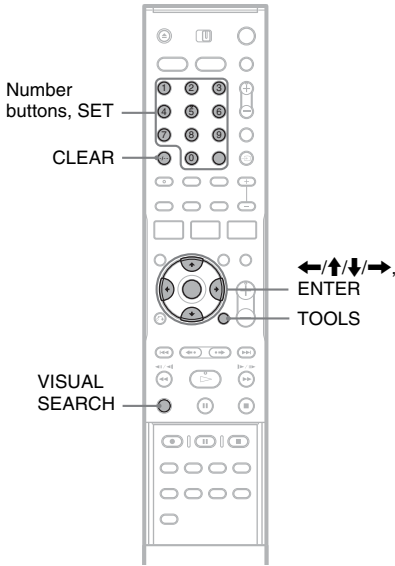

Searching by Thumbnail (Visual Search)

HDD +RW -RWVR -RWVideo +R -R

Each chapter is displayed as a thumbnail. You can search for the desired scene visually.

1 Press VISUAL SEARCH during playback.

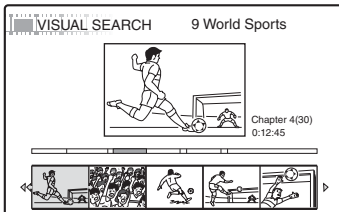

2 Select a scene using ←/→, and press ENTER.

Playback starts from the selected scene.

Searching by title number or time code

HDD +RW -RWVR -RWVideo +R -R
DVD VCD CD DATA CD

You can search a disc by title, chapter, scene or track. As titles and tracks are assigned individual numbers, select the title or track by entering its number. You can also search for a scene using the time code.

1 Press TOOLS during playback to select a search method, and press ENTER.

“Title Search” (for DVDs)

“Chapter Search” (for HDD/DVDs)

“Track Search” (for CDs/DATA CDs)

“Search” (for VIDEO CDs)

“Album Search” (for DATA CDs)

“Time Search” (for HDD/DVDs): Searches for a starting point using the time code.

“File Search” (for DATA CDs)

The display for entering the number appears.
Example: Title Search



The number in parentheses indicates the total number of titles, tracks, etc.

2 Press the number buttons to select the number of the title, chapter, track, time code, etc., you want.

For example: Time Search

To find a scene at 2 hours, 10 minutes, and 20 seconds, enter “21020.”

- If you make a mistake, press CLEAR to cancel the number, then select another number.

3 Press SET.

Playback starts from the selected point.

Note

“Title Search” is not applicable to the HDD.

Playing MP3 Audio Tracks or JPEG Image Files

DATA CD

You can play MP3 audio tracks and JPEG image files on DATA CDs (CD-ROMs/CD-Rs/CD-RWs).

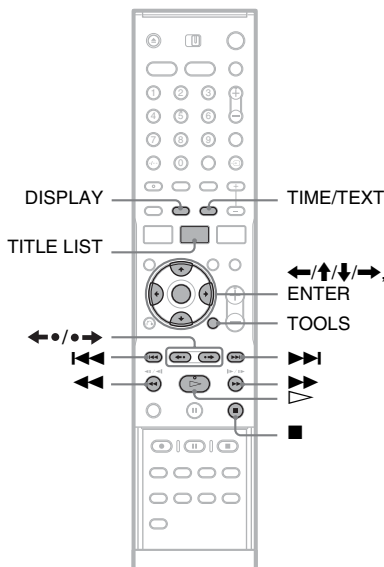

1 Insert a disc.

See “Inserting a disc” on page 36.

2 Press \triangleright .

For MP3 discs, playback starts from the first MP3 audio track on the disc.

For JPEG files, a slideshow of the pictures on the disc begins.

If the DATA CD contains both MP3 audio tracks and JPEG image files, playback starts from the JPEG image files the first time \triangleright is pressed.

Selecting an MP3 album or track

1 Press TITLE LIST.

The album list appears.

To change the page, press $\leftarrow \bullet / \bullet \rightarrow$.

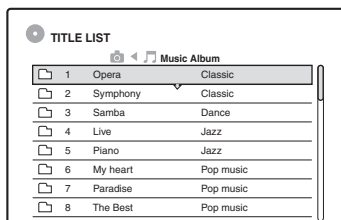

2 Select an album, and press ENTER.

The sub-menu appears.

3 Select “View Album,” and press ENTER.

The track list appears.

To change the page, press $\leftarrow \bullet / \bullet \rightarrow$.

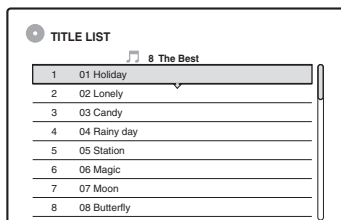

4 Select a track, and press ENTER.

“Play”: Plays the track.

“Play Beginning”: Plays the beginning of the track.

“Track Data”: Shows information about the track such as artist and album name.

To stop playback

Press \blacksquare .

To fast forward or review a track

Press \lll / \ggg during playback.

To go to the next or previous MP3 audio track

Press \lll / \ggg during playback.

To go to the next or previous album

During playback, press $\leftarrow \bullet / \bullet \rightarrow$ or press \lll / \ggg repeatedly.

Hint

Press the  (audio) button to switch between stereo or monaural audio tracks.

Selecting a JPEG album or image

1 Press TITLE LIST.

The album list appears.

To change the page, press /•/•>.

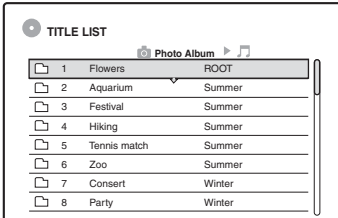

2 Select an album, and press ENTER.

The sub-menu appears.

3 Select “View Album,” and press ENTER.

The image list appears.

To change the page, press /•/•>.

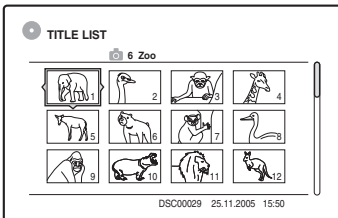

4 Select an image, and press ENTER.

“View Image”: Shows the image on the entire screen.

“Slideshow”: Shows the images in the album as a slideshow.

“Image Data”: Shows when the picture was taken.

To stop viewing the JPEG image

Press .

To view the next or previous picture

Press •/•> while a picture is displayed.

To rotate a picture

Press TOOLS while the image is displayed to select “Rotate Right” or “Rotate Left,” and press ENTER. Or press /•> while viewing the image.

To change the slideshow speed

Press TOOLS while the album list or image list is displayed to select “Slideshow Speed,” and press ENTER. Then select the speed from “Fast” (quick), “Normal,” and “Slow.”



To go to the next or previous album

Press /•/•> while the JPEG image is displayed.

Hints

- If you are playing a DATA CD that has both MP3 and JPEG files, you can switch between music and photo albums by using the /•> buttons when the album list is displayed.
- Press DISPLAY repeatedly to show information about the JPEG album or image on your TV screen. Then press TIME/TEXT to toggle between the current selected image number and album number.

Notes

- If the DVD disc, such as a disc from a DVD video camera, contains both video and JPEG images, only the video can be played back.
- Some JPEG files, especially files of three million pixels or more, may lengthen the slideshow interval.
- Rotated JPEG images will not be saved when you press  or switch to another album.
- Images larger than 720 × 480 will be reduced to 720 × 480 when displayed.
- Images larger than 4 mega bytes cannot be displayed.
- Progressive JPEG images cannot be displayed.
- When you attempt to play a broken file or a file that does not satisfy the play conditions,  appears, indicating the recorder cannot play the file.

About MP3 audio tracks and JPEG image files

MP3 is audio compression technology that satisfies ISO/MPEG regulations. JPEG is image compression technology.

You can play MP3 (MPEG1 Audio Layer 3) format audio tracks and JPEG image files on DATA CDs (CD-ROMs/CD-Rs/CD-RWs). DATA CDs discs must be recorded according to ISO9660 Level 1, Level 2 or Joliet format for the recorder to recognize the MP3 tracks.

See the instructions supplied with the CD-R/CD-RW drives and the recording software (not supplied) for details on the recording format.

Note on Multi Session/Border discs

If MP3 audio tracks or JPEG image files are recorded in the first session/border, the recorder will also play MP3 audio tracks or JPEG image files in other sessions/borders. If audio tracks and images in Music CD format or Video CD format are recorded in the first session/border, only the first session/border will be played back.

Note

The recorder may not be able to play certain DATA CDs created in the Packet Write format.

MP3 audio tracks or JPEG image files that the recorder can play

The recorder can play the following tracks and files:

- MP3 audio tracks with the extension “.MP3,” “.mp3,” or “Mp3.”
- JPEG image files with the extension “.JPEG,” “.jpg,” “.JPG,” “.Jpg,” “.jpeg,” or “.Jpeg.”
- JPEG image files that conform to the DCF* image file format.

* “Design rule for Camera File system”: Image standards for digital cameras regulated by JEITA (Japan Electronics and Information Technology Industries Association).

Notes

- The recorder will play any data with the extension “.MP3,” “.mp3,” “Mp3,” “.JPEG,” “.jpg,” “.JPG,” “.Jpg,” “.jpeg,” or “.Jpeg” even if they are not in MP3 or JPEG format. Playing such data may generate a loud noise which could damage your speaker system.
- The recorder does not conform to audio tracks in mp3PRO format.
- Certain files cannot be played.
- Letters that cannot be displayed are replaced with “*.”
- The recorder may not display JPEG images edited by PC software, etc., if the software does not conform to DCF.

About playback order of albums, tracks, and files

Albums play in the following order:

Structure of disc contents

Tree 1 Tree 2 Tree 3 Tree 4 Tree 5

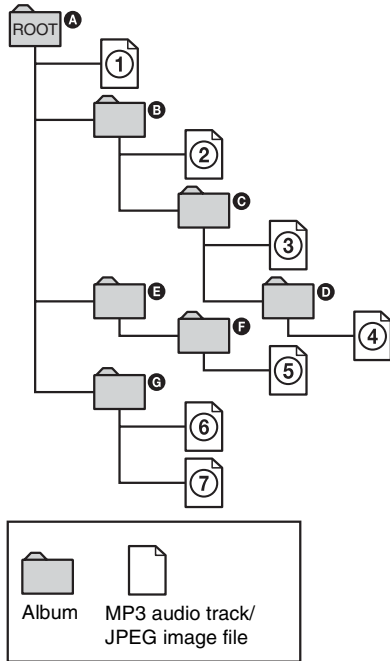

When you insert a DATA CD and press \triangleright , the numbered tracks (or files) are played sequentially, from ① through ⑦. Any sub-albums/tracks (or files) contained within a currently selected album take priority over the next album in the same tree. (Example: C contains D so ④ is played before ⑤.) When you press TITLE LIST and the list of album names appears (page 67), the album names are arranged in the following order: A → B → C → D → F → G. Albums that do not contain tracks (or files) (such as album E) do not appear in the list.

💡 Hints

- If you add numbers (01, 02, 03, etc.) to the front of the track/file names when you store tracks (or files) in a disc, they will be played in that order.
- Since a disc with many trees takes longer to start playback, it is recommended that you create albums with no more than two trees.

Notes

- Depending on the software you use to create the DATA CD, the playback order may differ from the above illustration.
- No more than a total of 199 individual albums can be played. (Albums that do not contain JPEG/MP3 files are also counted.)
- No more than a total of 999 albums and files can be played. (Files other than JPEG/MP3 files, and albums that do not contain JPEG/MP3 files are also counted.)
- No more than a total of 200 albums and files can be recognized in a single album. (Albums that do not contain JPEG/MP3 files are also counted.)
- Proceeding to the next or another album may take some time.
- This recorder supports MP3 audio bit rates up to 160 kbps.

Before Editing

This recorder offers various edit options for different disc types. Before you edit, check the disc type in the front panel display, and select the option available for your disc (page 8).

Notes

- You may lose the edited contents if you remove the disc or a timer recording starts while editing.
- DVD discs created by DVD video cameras cannot be edited on this recorder.

Edit options for the HDD and DVD-RWs (VR mode)

HDD -RWVR

You can enjoy advanced edit functions. First you have two options for the HDD and DVD-RWs (VR mode): editing either the original recording (called the “original”), or the playback information created from the original (called a “Playlist”). Since each is different in nature and offers different merits, read the following and select the one that better suits your needs.

To edit original titles

Edits made to the original titles are final. If you plan to retain an unaltered original recording, create a Playlist to edit (see below). The edit functions available for original titles are:

- Labelling a title (page 72).
- Setting protection against erasure (page 72).
- Erasing a title (page 72).
- Erasing multiple titles (page 74).
- Erasing a section of a title (A-B Erase) (page 73).
- Erasing all titles on the disc (page 75).
- Erasing a chapter (page 73).
- Dividing one title into two titles (HDD only) (page 74).

To create and edit Playlist titles

A Playlist is a group of Playlist titles created from the original title for editing purposes. When you create a Playlist, only the control information necessary for playback, such as the playback order, is stored on the disc. Since the original titles are left unaltered, Playlist titles can be re-edited.

Example: You have recorded the final few matches of a football tournament on a DVD-RW (VR mode). You want to create a digest with the goal scenes and other highlights, but you also want to keep the original recording.

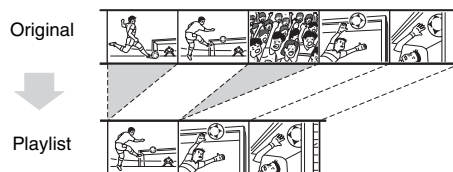

In this case, you can compile highlight scenes as a Playlist title. You can even rearrange the scene order within the Playlist title (“Creating and Editing a Playlist” on page 76).

The advanced edit functions available for Playlist titles are:

- Setting protection against erasure (HDD only) (page 72).
- Labelling a title (page 72).
- Erasing a title (page 72).
- Erasing multiple titles (page 74).
- Erasing a section of a title (A-B Erase) (page 73).
- Rearranging the title order (DVD-RWs (VR mode) only) (page 77).
- Dividing a title into multiple titles (page 74).
- Combining multiple titles into one title (page 77).
- Erasing a chapter (page 73).

💡 Hint

You can display the disc’s Playlist titles in the Title List (Playlist), or the original titles in the Title List (Original). To switch the two Title Lists, press TOOLS while a Title List is displayed, and select “Original” or “Playlist.”

Notes

- A Playlist title calls up data from the original titles for playback. When an original title is used for a Playlist title, the original title cannot be erased.
- If a message appears and indicates that the disc's control information is full, erase or edit unnecessary titles.
- Playlist titles containing titles recorded with the "Copy-Once" copy protection signal cannot be dubbed or moved (page 80).

Edit options for DVD+RWs/DVD-RWs (Video mode)/DVD+Rs/DVD-Rs

+RW -RW_{Video} +R -R

You can perform simple edits. Since Video mode titles are actual recordings on the disc, you cannot undo any edits you make. The edit functions available for Video mode titles are:

- Setting protection against erasure (page 72).
- Labelling a title (page 72).
- Erasing a title (page 72).
- Erasing multiple titles (page 74).
- Erasing a section of a title (A-B Erase) (DVD+RWs only) (page 73).
- Erasing all titles on the disc (page 75).
- Erasing titles to open up disc space (Disc Map) (DVD+RWs and DVD-RWs (Video mode) only) (page 75).

Notes

- When editing a DVD+R or DVD-R, finish all editing before finalizing the disc. You cannot edit a finalized disc.
- The available disc space does not increase even when you erase titles for DVD+Rs and DVD-Rs.
- If a message appears and indicates that the disc's control information is full, erase or edit unnecessary titles.

Erasing and Editing a Title

HDD +RW -RW_{VR} -RW_{Video} +R -R

This section explains the basic edit functions. Note that editing is irreversible. To edit the HDD or DVD-RWs (VR mode) without changing the original recordings, create a Playlist title (page 76).

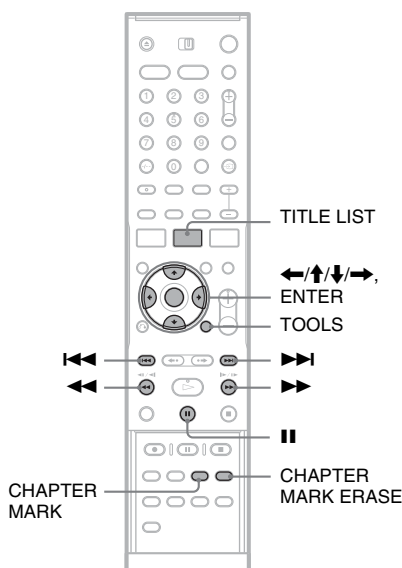

1 Press TITLE LIST.

- For HDD titles or DVD-RWs in VR mode, press TOOLS and select "Original" or "Playlist" from the TOOLS menu to switch the Title Lists, if necessary.

2 Select a title, and press ENTER.

The sub-menu appears.

3 Select an option, and press ENTER.

You can make the following edits to the title.

"Erase": Erases the selected title. Select "OK" when asked for confirmation.

"Protect": Protects the title. Select "On" when the Protection display appears. "🔒" appears next to the protected title. To cancel the protection, select "Off."

"Title Name": Allows you to enter or re-enter a title name (page 43).

"Set Thumbnail": Changes the title's thumbnail picture that appears in the Title List (page 41).

“A-B Erase”: Erases a section of the title (page 73).

“Delete Chapter”: Erases chapter units of the title while viewing thumbnails (see below).

“Divide”: Divides a title into two titles (page 74).

💡 Hints

- You can erase multiple titles at one time (page 74), or erase all of the titles on a disc at once (page 75).
- You can automatically erase titles that have already been played (page 57).
- You can label or re-label DVDs (page 45).

Note

DVD-RW (VR mode) Playlist titles cannot be protected.

Erasing a chapter (Delete Chapter)

HDD -RWVR

Thumbnails are displayed for each chapter. You can easily select and erase a section in a title.

Note that erasing a chapter cannot be undone.

1 After step 2 of “Erasing and Editing a Title,” select “Delete Chapter,” and press ENTER.

2 Select a thumbnail of the chapter using \leftarrow/\rightarrow , and press ENTER.

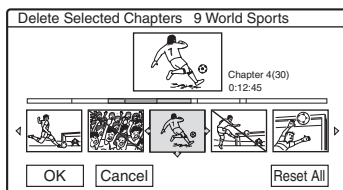

- To cancel the selection, press ENTER again.
- To erase multiple chapters, repeat step 2.
- To reset all selections, select “Reset All.”

3 Select “OK,” and press ENTER.

The display asks for confirmation.

4 Select “Yes,” and press ENTER.

Erasing a section of a title (A-B Erase)

HDD +RW -RWVR

You can select a section (scene) in a title and erase it. Note that erasing scenes in a title cannot be undone.

1 After step 2 of “Erasing and Editing a Title,” select “A-B Erase” and press ENTER.

The display for setting point A appears.

- To return to the beginning of the title, press \blacksquare and then press \blacktriangleleft repeatedly.

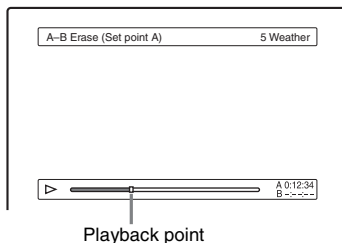

2 Select point A by pressing $\blacktriangleleft/\blacktriangleright$, and press ENTER.

The display for setting point B appears.

3 Select point B by pressing $\blacktriangleleft/\blacktriangleright$, and press ENTER.

The display asks for confirmation.

- To reset either point A or B, select “Change A” or “Change B,” and go to step 2 or 3.
- To preview the title without scenes to be erased, select “Preview” (except for DVD+RWs).

4 Select “OK,” and press ENTER.

The scene is erased, and the display asks whether to erase another scene.

- To continue, select “Yes,” and repeat from step 2.
- To finish, select “No.”

💡 Hint

A chapter mark is inserted after the scene was erased. The chapter mark divides the title into separate chapters on either side of the mark.

Notes

- Images or sound may be momentarily interrupted at the point where you erase a section of a title.
- Sections shorter than five seconds may not be erased.
- For DVD+RWs, the erased section may be slightly different from the points you selected.

Erasing multiple titles (Erase Titles)

HDD +RW -RWVR -RW_{Video} +R -R

You can select and erase more than one title at one time using the TOOLS menu.

1 Press TITLE LIST.

2 Press TOOLS, select “Erase Titles,” and press ENTER.

The display for selecting titles to be erased appears.

3 Select a title, and press ENTER.

A check mark appears in the check box next to the selected title.

- To clear the check mark, press ENTER again.
- To clear all of check marks, select “Reset All.”

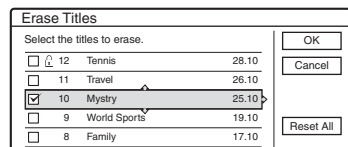

4 Repeat step 3 to select all of the titles you want to erase.

5 When you finish selecting titles, select “OK,” and press ENTER.

The list of titles to be erased appears for confirmation.

- To change the selection, select “Change,” and repeat from step 3.

6 Select “OK,” and press ENTER.

The titles are erased.

Dividing a title (Divide)

HDD -RWVR *

If you want to dub a long title to a disc but do not want to reduce the picture quality, divide the title into two shorter titles. Note that dividing a title cannot be undone.

* Only Playlist titles can be divided for DVD-RW (VR mode).

1 Press TITLE LIST.

- Press TOOLS and select “Original” or “Playlist” from the TOOLS menu to switch the Title Lists, if necessary.

2 Select a title, and press ENTER.

The sub-menu appears.

3 Select “Divide,” and press ENTER.

The display for setting the dividing point appears. The title starts to play in the background.

- To return to the beginning of the title, press **II** and then press **◀◀** repeatedly.

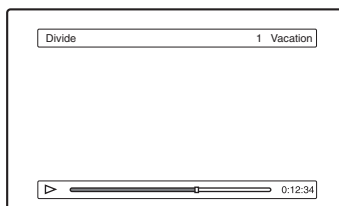

4 Select the dividing point by pressing **◀◀/▶▶**, and press ENTER.

The display asks for confirmation.

- To change the dividing point, select “Change.”

5 Select “OK,” and press ENTER.

The display for entering the title name appears.

- To use the same title name as before, select “No.”

6 Select “Yes,” and press ENTER to enter a new name.

Follow the explanations on page 43. After you enter a new name, the title is divided into two.

Erasing all titles on a disc

HDD **+RW** **-RWVR** **-RWVideo** **+R** **-R**

- 1 Press **TOOLS**, select “Disc Info,” and press **ENTER**.

The “Disc Information” display appears.

- 2 Select “Erase All,” and press **ENTER**.

- 3 Select “OK,” and press **ENTER**.

All titles on the disc are erased (except the protected titles).

Erasing titles to open up disc space (Disc Map)

+RW **-RWVideo**

When recording on a DVD+RW or DVD-RW (Video mode), the recorder searches for the largest open space and records there. Before you start, check the disc status by using Disc Map, and erase titles to create a space large enough for the recording.

- 1 Insert a disc and press **TITLE LIST**.

- 2 Press **TOOLS**, select “Disc Map,” and press **ENTER**.

The “Disc Map” display appears.

- To check the open space, select the space by pressing **←/→**.

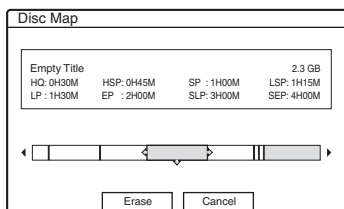

- When **←** or **→** appears on either side of the screen, you can scroll sideways by pressing **←/→**.

- 3 Select a title by pressing **←/→**, and press **ENTER**.

The display for selecting titles to be erased appears.

- To cancel the selection, press **ENTER** again.
- To erase more titles, repeat step 3.

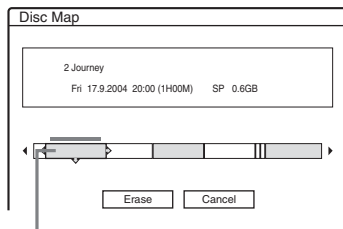

Selected title

- 4 Select “Erase,” and press **ENTER**.

The display asks for confirmation.

- 5 Select “OK,” and press **ENTER**.

The selected titles are erased, freeing up disc space.

- To change the selection, select “Change.”

Creating chapters manually

HDD **-RWVR**

You can manually insert a chapter mark at any point you like during playback or recording.

Press CHAPTER MARK at the point where you want to divide the title into chapters.

Each time you press the button, “Marking...” appears on the screen and the scenes to the left and right of the mark become separate chapters.

To erase chapter marks

You can combine two chapters by erasing the chapter mark during playback.

Press **◀◀/▶▶** to search for a chapter number, and while displaying the chapter containing the chapter mark you want to erase, press **CHAPTER MARK ERASE**.

The current chapter combines with the previous chapter.

Notes

- When dubbing, any chapter marks you enter will be erased.
- To insert a chapter mark manually during recording, set “Auto Chapter” in “Features” setup to “Off.”

Creating and Editing a Playlist

HDD -RWVR

Playlist edit allows you to edit or re-edit without changing the actual recordings. You can create up to 97 Playlist titles.

Note

Once you create a Playlist title from original titles, you will be unable to erase or edit the original titles.

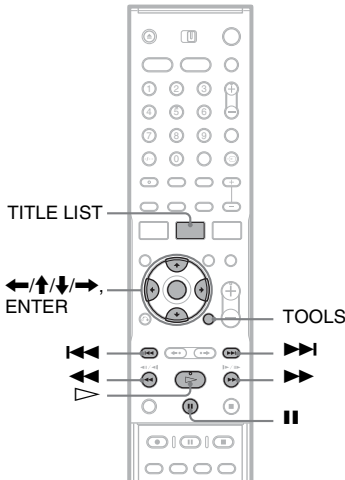

- 1 Press **TITLE LIST**.
- 2 Press **TOOLS**, select “Create Playlist,” and press **ENTER**.

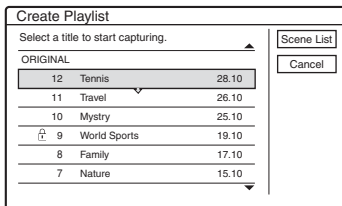

- 3 Select the title you want to include in the **Playlist title**, and press **ENTER**.

The sub-menu appears.

“Capture”: Adds a section of the title to the Playlist title as one scene.

“Capture All”: Adds the entire title to the Playlist title as one scene. After capturing the title, go to step 8.

- 4 Select “**Capture,**” and press **ENTER**.

The display for setting the start point (IN) appears. The title starts to play in the background.

- To return to the beginning of the title, press **II** and then press **II<<<**.

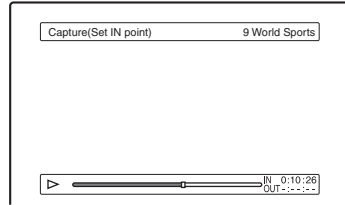

- 5 Select the **IN** point by pressing **◀/▶**, and press **ENTER**.

The display for setting the end point (OUT) appears, and the title continues to play in the background.

- 6 Select the **OUT** point by pressing **◀/▶**, and press **ENTER**.

The display asks for confirmation.

- To reset the IN or OUT point, select “Change IN” or “Change OUT” and repeat step 5 or 6.
- To view the selected scene, select “Preview.”

- 7 Select “**OK,**” and press **ENTER**.

The Scene List menu appears with all of the selected scenes.

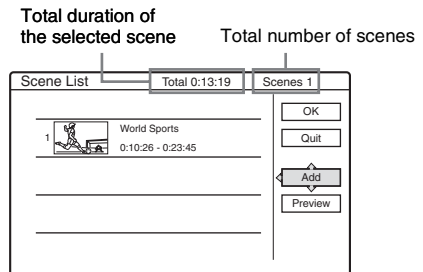

- To add more scenes, select “Add” and go to step 3.
- To preview all of the captured scenes in the listed order, select “Preview.”

8 Select the scene you want to re-edit, and press ENTER.

The sub-menu appears.

“Move”: Changes the scene order.

“Erase”: Erases the scene. The selection is cancelled.

“Preview”: Displays thumbnail pictures of the scenes.

“Change IN”: Allows you to change the IN point, by repeating from step 5.

“Change OUT”: Allows you to change the OUT point, by repeating from step 6.

9 When you finish editing the Scene List, select “OK,” and press ENTER.

The display for entering the title name appears.

- To enter a new name, select “Enter” and follow the explanations on page 43.

10 Select “OK” to use the default name, and press ENTER.

To play the Playlist title

Press TOOLS while the Title List menu is turned on. Then, select “Playlist” and press ENTER.

When the Title List (Playlist) menu appears, select a title and press \triangleright .

Hint

When a Playlist title is created, the IN and OUT points will become chapter marks, and each scene will become a chapter.

Note

The picture may pause when the edited scene is played.

Moving a Playlist title (Change Order)

-RWVR

You can change the Playlist title order within the Title List (Playlist).

1 Press TITLE LIST to turn on the Title List (Playlist) menu.

- If the Title List (Original) menu appears, press TOOLS and select “Playlist.”

2 Select the title you want to move, and press ENTER.

The sub-menu appears.

3 Select “Change Order,” and press ENTER.

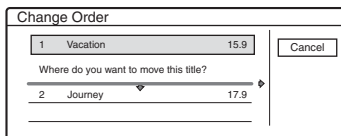

4 Select a new location for the title by pressing \uparrow/\downarrow , and press ENTER.

The title moves to the new location.

Combining multiple Playlist titles (Combine)

HDD -RWVR

1 Press TITLE LIST to turn on the Title List (Playlist) menu.

- If the Title List (Original) menu appears, press TOOLS and select “Playlist.”

2 Press TOOLS, select “Combine,” and press ENTER.

The display for selecting titles appears.

3 Select a title, and press ENTER.

A number indicating the order in which you selected the title appears.

- To cancel the selection, press ENTER again.

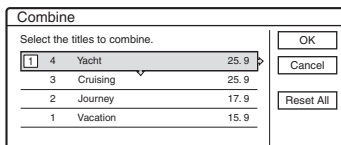

4 Repeat step 3 to select all of the titles you want to combine.

- To cancel all of the selections, select “Reset All.”

5 Select “OK,” and press ENTER.

The list of titles to be combined appears.

- To change the selection, select “Change” and go to step 3.

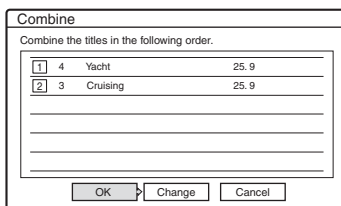

6 Select “OK,” and press ENTER.

The display for selecting a title name from among the selected titles appears.

- To enter a new name, select “Enter Text,” and follow the explanations on page 43.
- To change the selection, select “Change” and go to step 3.

7 Select a name, and press ENTER.

The titles are combined.

Note

When the number of chapters in the title to be combined exceeds the limit, the chapters at the end are combined into a single chapter.

Dividing a Playlist title (Divide)

HDD **-RWVR**

You can divide a Playlist title. For details, see page 74.

Before Dubbing

HDD +RW -RW/VR -RW/video +R -R

In this section, “dubbing” refers to “copying a recorded title on the internal hard disk drive (HDD) to another disc, or vice versa.” You can select to dub one title at a time (Title Dubbing – see “Dubbing a single title (Title Dub)” on page 81), or multiple titles all at once (Multiple Title Dubbing – see “Dubbing multiple titles (Dub Selected Titles)” on page 82).

To record from equipment connected to the LINE IN jacks, see “Recording from connected equipment without a timer” on page 59.

Before you start, read the following precautions, which are common to both dubbing methods.

Before you start...

- Select the disc type according to your needs (page 8). This recorder can record on various discs.
- You cannot record both the main and sub sound on a DVD+RW, DVD-RW (Video mode), DVD+R, or DVD-R. For bilingual programmes, set “DVD Bilingual Rec.” to either “Main” (default) or “Sub” in “Options” setup (page 103).
- Timer recording and Synchro-Recording do not start during dubbing. Before you start, check the Timer List menu to see if there is any timer recording due to start during dubbing.
- When “Auto Chapter” of “Features” setup is set to “On,” chapter marks are automatically inserted at approximately 6-minute intervals while dubbing from the HDD to a DVD, or when the recorder detects picture and sound changes while dubbing from a DVD to the HDD. The chapter marks in the dubbing source are not retained in the dubbed title.
- For titles with mixed picture sizes (16:9 or 4:3):
 - When dubbed from the HDD to DVD-RW (Video mode) or DVD-R, the picture size is determined by the setting in “DVD Rec. Picture Size” (page 54).
 - When dubbed from HDD to DVD+RW or DVD+R, the picture size is always 4:3.

- When dubbed from HDD to DVD-RW (VR mode), the originally recorded picture sizes are retained.

Hints

- When you dub a Playlist title, it is recorded as an original title.
- When dubbed from a DVD to the HDD, the picture sizes and the sound types originally recorded are retained.

Notes

- To play a dubbed disc on other DVD equipment, finalize the disc (page 46).
- The recorder may not function as described depending on the disc status. Follow the instructions that appear on the screen.
- You cannot dub from DVD VIDEOS to the HDD.
- Thumbnails that you have set for the originally recorded title (page 41) will not be retained in the dubbed title.

About “Dub Mode”

With this recorder, the recording mode for dubbing is displayed as “Dub Mode.” Two dubbing methods are available: High-speed Dubbing and Rec Mode Conversion Dubbing. Read the following and select according to the required time, disc space, and picture quality.

Dubbing at high-speed (High-speed Dubbing)

HDD → +RW / -RW/VR / -RW/video / +R / -R

Allows you to dub what you have stored in the HDD to a high-speed DVD (8x-speed DVD+RWs/6x-speed DVD-RWs/16x-speed DVD+Rs/16x-speed DVD-Rs, or slower versions of each disc type), without changing the recording mode.

Set “Dub Mode” to “Fast” in “Title Dub” or “Dub Selected Titles” display (page 81). You cannot select “Fast” when titles that cannot be dubbed at high speed are selected (such as the titles displayed in “Notes” below). The minimum required time is as follows (approximate).

Required times for High-speed Dubbing from HDD to DVD (for a 60-minute programme)*1

Speed*2	6x	6x*3	8x*4	8x*4	2.4x
Rec. mode	High-speed DVD-RW	High-speed DVD+RW	High-speed DVD-R	High-speed DVD+R	DVD+R (Double Layer)
HQ	10 min.	10 min.	8 min.	8 min.	25 min.
HSP	6 min. 40 sec.	6 min. 40 sec.	5 min.	5 min.	16 min. 40 sec.
SP	5 min.	5 min.	3 min. 45 sec.	3 min. 45 sec.	12 min. 30 sec.
LSP	4 min.	4 min.	3 min.	3 min.	10 min.
LP	3 min. 20 sec.	3 min. 20 sec.	2 min. 30 sec.	2 min. 30 sec.	8 min. 20 sec.
EP	2 min. 30 sec.	2 min. 30 sec.	2 min.	2 min.	6 min. 15 sec.
SLP	1 min. 40 sec.	60 min.*5	1 min. 15 sec.	60 min.*5	60 min.*5
SEP	1 min. 15 sec.	60 min.*5	56 sec.	60 min.*5	60 min.*5

*1 The values in the above table are for reference only. Actual times for dubbing also require time for creating the disc's control information and other data.

*2 This is the maximum recording speed of this recorder. The value may vary depending on the disc condition. Also, this recorder may be unable to record at the maximum speed for discs that support recording speeds exceeding the maximum value.

*3 The maximum drive speed of this recorder is 6x when using 6x-speed or faster DVD+RWs.

*4 The maximum drive speed of this recorder is 8x when using 8x-speed or faster DVD+Rs/DVD-Rs.

*5 High-speed dubbing is not available when dubbing titles recorded in SLP and SEP mode to DVD+RWs and DVD+Rs.

Notes

- High-speed Dubbing is not available for the following titles:
 - Titles recorded in HQ+.
 - Titles that contain both main and sub sounds (except DVD-RWs (VR mode)).
 - Titles recorded with mixed picture sizes (4:3 and 16:9 etc.), (except DVD-RWs (VR mode)).
- When dubbed to a DVD-RW (Video mode)/DVD+RW/DVD+R/DVD-R, remnants of edited titles may remain on the disc. If you edit a title, use the Rec Mode Conversion Dubbing method. This will smooth out the pauses between the scenes.
- When dubbing to a DVD+R DL disc, the video may be momentarily interrupted at the point where the layers switch.

Rec Mode Conversion Dubbing



Allows you to dub from the HDD to a DVD or vice versa, in a dubbing mode that differs from the original recordings. For example, when you dub an HQ title (data size is large) in SP mode, you can reduce the data size, saving more titles using less space.

Select a mode different from the original recording in "Dub Mode" in the steps of "Dubbing a single title (Title Dub)" on page 81 or "Dubbing multiple titles (Dub Selected Titles)" on page 82. When a title recorded to HDD in HQ or HQ+ mode is converted to another mode, the recorder automatically assigns an appropriate bit rate, thus retaining the original picture quality as much as possible.

Note

The picture quality will not improve even if a title is converted to a recording mode of better picture quality.

Dubbing restriction

You cannot dub movies and other DVD VIDEOS to the HDD. Also, when dubbing from a DVD to the HDD, a grey, blank screen will be recorded for scenes that contain a copy protection signal.

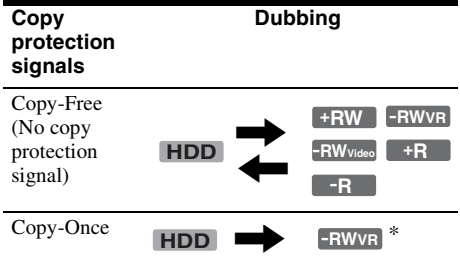

* CPRM-compatible DVD-RWs (VR mode) only
CPRM (Content Protection for Recordable Media) is a coding technology that protects copyrights for images.

Move



Titles containing "Copy-Once" copy protection signals can be moved only from HDD to DVD-RW (VR mode)* (after the title is moved, the original title in the HDD is erased). The "Move" function is performed using the same procedure as dubbing (page 81). Titles containing "Copy-Once" copy protection signals are indicated with



Notes

- The following titles in the HDD cannot be moved.
 - Protected titles
 - Playlist titles
 - Original titles referenced from the Playlist
 - If the move operation is stopped before completion, the title in the HDD is not erased.
- * CPRM-compatible DVD-RWs (VR mode) only.

Dubbing

HDD +RW -RWVR -RWVideo +R -R

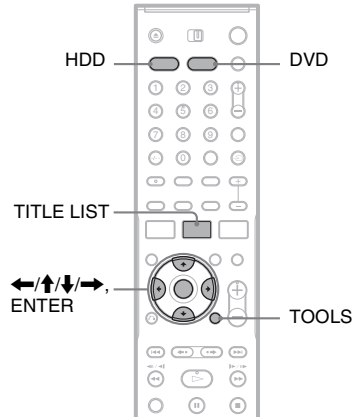

Dubbing (HDD ↔ DVD)

Dubbing a single title (Title Dub)

- 1 Insert the DVD that you are going to dub to or from.
- 2 Press **HDD** or **DVD** to select the source.
- 3 Press **TITLE LIST** to turn on the Title List menu.
- 4 Select a title, and press **ENTER**.
The sub-menu appears.
- 5 Select “Dubbing,” and press **ENTER**.

The display for selecting the dubbing mode appears.
If a title with **COPY** (page 80) is selected in the title list, a confirmation screen is displayed. To “Move,” select “Yes.”

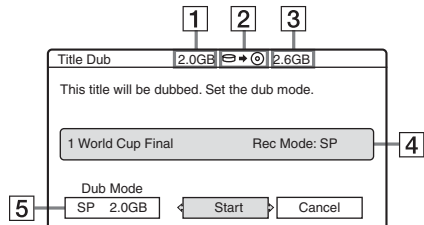

- 1 Size of the title (approximate)
- 2 Direction of dubbing

- 3 Available space on the disc to be dubbed (approximate)
- 4 Information about the title to be dubbed
- 5 Dubbing mode and the size of the title after dubbing (approximate)

6 Select "Dub Mode."

7 Select a dubbing mode by pressing ↑/↓.

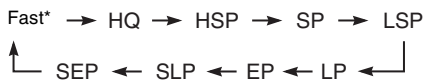

* Appears when High-speed Dubbing is available for the title (page 79).

8 Select "Start," and press ENTER.

The dubbing indication appears in the front panel display (page 42).

To automatically adjust the dubbing mode (Auto Dub Mode)

If there is not enough available space on the target disc, the recorder automatically selects a dubbing mode with lower picture quality according to the available space. If there is insufficient disc space in the selected dubbing mode, the following display appears after step 8.

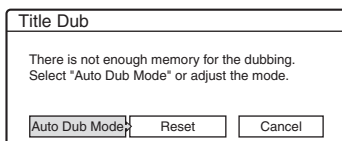

Select "Auto Dub Mode" and press ENTER to start dubbing. To manually select another dubbing mode, select "Reset," and go to step 7.

To stop dubbing

Press TOOLS, select "Stop Dubbing," and press ENTER. When asked for confirmation, select "Yes," and press ENTER.

💡 Hints

- If disc space is still insufficient for the selected dubbing mode, erase unnecessary parts of the title, or free up disc space by erasing titles on the disc (page 72).
- You can turn off the recorder during dubbing. The recorder completes dubbing even after being turned off.

Dubbing multiple titles (Dub Selected Titles)

A maximum of 30 selected titles can be dubbed at once. You can select the dubbing mode for each title.

- 1 Insert the DVD that you are going to dub to or from.
- 2 Press HDD or DVD to select the source.
- 3 Press TITLE LIST to turn on the Title List menu.
- 4 Press TOOLS, select "Dub Selected Titles," and press ENTER.

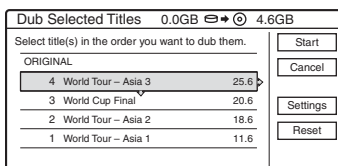

5 Select titles in the order you want to dub, and press ENTER.

The titles are numbered in the selected order.

- To cancel the selection, press ENTER again.
- If a title with COPY (page 80) is selected in the title list, a confirmation screen is displayed.

To "Move," select "Yes."

6 Repeat step 5 to select all of the titles you want to dub.

- To make adjustments for each of the titles, select "Settings" (see "To adjust the settings for each title" below).
- To cancel all of the selections, select "Reset," and go to step 5.

7 Select "Start," and press ENTER.

The dubbing indication appears in the front panel display (page 42).

To adjust the settings for each title

You can make detailed settings for each of the selected titles during Multiple Title Dubbing.

- 1 In step 6 of “Dubbing multiple titles (Dub Selected Titles)” on page 82, select “Settings” and press ENTER.

The following display for making the adjustments appears.

- To re-select titles, select “Change,” and go to step 5 of “Dubbing multiple titles (Dub Selected Titles)” above.
- To have the recorder adjust the dubbing mode so all of the selected titles fit in, select “Auto mode.”

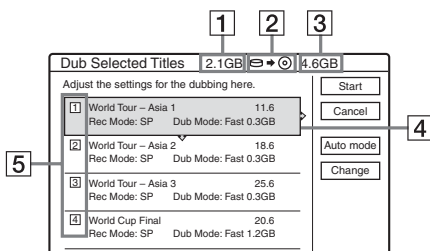

- 1 Total size of the selected titles
 - 2 Direction of dubbing
 - 3 Available space on the disc to be dubbed (approximate)
 - 4 Information about the title to be dubbed (title name, original recording mode, dubbing mode, and data size after dubbing)
 - 5 Order of dubbing
- 2 Select the title you want to adjust, and press ENTER.
The sub-menu appears.
“Dub Mode”: Selects the dubbing mode for each title (page 79).
“Change Order”: Moves the title to change the dubbing order. Press \uparrow/\downarrow to select a new location, and press ENTER.
“Cancel”: Cancels the title selection. The title is excluded from dubbing.
 - 3 Select an option, and press ENTER.
 - 4 When you finish making adjustments, select “Start,” and press ENTER.

To automatically adjust the dubbing mode (Auto Dub Mode)

If there is not enough available space on the target disc, the recorder automatically selects a dubbing mode with lower picture quality according to the available space. The same dubbing mode is set for all of the titles. If disc space is insufficient for the selected dubbing mode, the following display appears after step 7 of “Dubbing multiple titles (Dub Selected Titles)” on page 82.

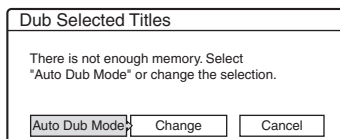

Select “Auto Dub Mode” and press ENTER. If you have selected only one title, select “OK.”

To stop dubbing

Press TOOLS, select “Stop Dubbing,” and press ENTER. When asked for confirmation, select “Yes,” and press ENTER.

💡 Hints

- You can turn off the recorder during dubbing. The recorder completes dubbing even after being turned off.
- You can start Multiple Title Dubbing by selecting “DUBBING” from the System Menu.

Speaker Surround Options

Selecting the Sound Field

You can take advantage of surround sound simply by selecting one of the system's preprogrammed sound fields, which bring the exciting and powerful sound of a movie theatre into your home.

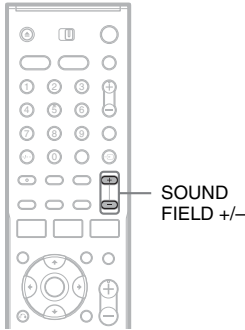

Press **SOUND FIELD +/-** to select one of the sound fields.

Example:



The front panel display changes as follows. For details, see the pages in parentheses.

Sound Field	
"A. F. D. AUTO"	Outputs the originally recorded sound with no sound effects (page 84).
"PRO LOGIC" "PLII MOVIE" "PLII MUSIC"	Outputs 2 channel sources like CDs as 5.1 channel. Dolby Pro Logic produces five channels from 2 channel sources (page 84).
"C. ST. EX A" "C. ST. EX B" "C. ST. EX C"	Produces an ideal movie theatre sound environment using DCS (Digital Cinema Sound) technology (page 85).

Sound Field

"MULTI ST." "REAR ST."	Outputs 2 channel sources from the front, centre, and surround speakers, or surround speakers only (page 85).
"HALL" "JAZZ CLUB" "L. CONCERT" (live concert) "GAME" "SPORTS" "MONO MOVIE"	Provides sound suitable for the source (movies, music, sports, etc.).
"NIGHT"	You can enjoy sound effects or dialogue, as you would in a movie theatre, even at low volume. Useful for watching movies at night.
"2CH STEREO"	Outputs sound only from the front left and right speakers and subwoofer with no surround effects (page 84).

"A. F. D. AUTO" (Auto Format Direct Auto)

Presents the sound as it was recorded or encoded, without adding any effects (e.g. reverberation). The auto decoding function automatically detects the type of audio signal being input (Dolby Digital, DTS, or standard 2 channel stereo) and performs the proper decoding as necessary. If there are no low frequency signals (Dolby Digital LFE, etc.), it will generate a low frequency signal for output to the subwoofer.

"2CH STEREO" (2 Channel Stereo)

Outputs the sound from the front left and right speakers and subwoofer. Standard 2 channel (stereo) sources completely bypass the sound field processing. Multi-channel surround formats are downmixed to 2 channels.

"PRO LOGIC" (Dolby Pro Logic)

Produces five output channels from 2 channel sources. This mode performs Pro Logic decoding to the input signal and output to front, centre, and surround speakers.

Meanwhile, the surround channel becomes monaural.

“PLII MOVIE/PLII MUSIC” (Dolby Pro Logic II Movie/Music)

Produces five full-bandwidth output channels from 2 channel sources. This is done using an advanced, high-purity matrix surround decoder that extracts the spatial properties of the original recording without adding any new sounds or tonal colorations.

🔊 Hints

- If you do not want any surround effect, select “A.F.D. AUTO” or “2CH STEREO.”
- The system memorizes and applies the last sound field selected for the following occasions:
 - When listening to the radio.
 - When playing discs, such as DVDs.
 - When playing data on the HDD.
 - Occasions other than the above.

Note

When the input signal is a multi-channel source, Dolby Pro Logic and Dolby Pro Logic II Movie/Music are cancelled and the multi-channel source is output directly.

Outputting 2-channel sources from the front, centre, and surround speakers**“MULTI ST.” (Multi Stereo)**

Outputs 2-channel sources from the front, centre, and surround speakers simultaneously. Front and surround speakers output the same sound.

“REAR ST.” (Rear Stereo)

Outputs 2-channel sources from the surround speakers only. The front speakers output sound only if “Surround” of the “Size” setting in “Speaker” setup is set to “None” (page 100).

Enjoying Digital Cinema Sound (DCS)

In collaboration with Sony Pictures Entertainment, Sony measured the acoustics of their studios and integrated the measured data with proprietary DSP (Digital Signal Processor) technology to develop “Digital Cinema Sound,” which simulates an ideal movie theatre sound environment, based on the preference of the movie director, in your home.

“C. ST. EX A” (Cinema Studio EX A)

Reproduces the sound of Sony Pictures Entertainment “Cary Grant Theater” cinema production studio. This is a standard mode, great for watching most any type of movie.

“C. ST. EX B” (Cinema Studio EX B)

Reproduces the sound of Sony Pictures Entertainment “Kim Novak Theater” cinema production studio. This mode is ideal for watching science-fiction or action movies with lots of sound effects.

“C. ST. EX C” (Cinema Studio EX C)

Reproduces the sound of Sony Pictures Entertainment scoring stage. This mode is ideal for watching musicals or classic films where music is featured in the soundtrack.

About Cinema Studio EX

Cinema Studio EX is ideal for enjoying the movie software encoded in multi-channel format, such as Dolby Digital DVDs. This mode reproduces the sound of Sony Pictures Entertainment studios. Cinema Studio EX consists of the following three elements.

- Virtual Multi Dimension

Creates five sets of virtual speakers surrounding the listener from a single pair of actual surround speakers.

- Screen Depth Matching

In a movie theatre, sound seems to come from inside the movie screen. This element creates the same sensation in your listening room by shifting the sound of the front speakers “into” the screen.

- Cinema Studio Reverberation

Reproduces reverberation peculiar to a movie theatre. Cinema Studio EX is an integrated mode which operates these elements simultaneously.

Notes

- The virtual speaker effect may cause increased noise in the playback signal.
- When listening with sound fields that employ virtual speakers, you will not be able to hear any sound coming directly from the surround speakers.

Reinforcing Bass Frequencies (DSGX)

The DSGX (Extended Dynamic Sound Generator) function reinforces bass frequencies.

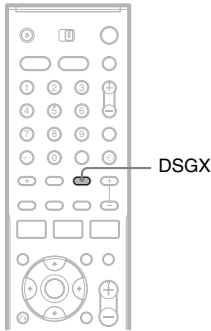

Press DSGX.

The DSGX function is activated, and “DSGX” appears in the front panel display.

- To cancel the function, press DSGX again.

Enjoying TV or VCR Sound From the Speaker System

You can enjoy the sound from connected equipment through the speakers of this system. Be sure to connect your TV or other equipment correctly.

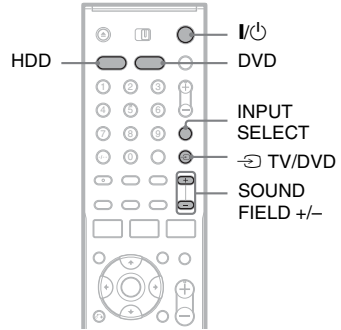

1 Press I/Power to turn on the system.

- If FM/AM is selected, press HDD or DVD.
- If you are using the SCART connection, press TV/DVD repeatedly to turn on the “TV” indicator in the front panel display, and select the desired sound on the TV or equipment.

2 Press INPUT SELECT repeatedly to select an input source according to the connection you made.

The front panel display changes as follows:

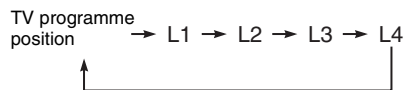

3 Press SOUND FIELD +/- to select the sound field you want.

Notes

- When you listen to the TV sound or stereo sound of a 2 channel source from the six speakers, select “PRO LOGIC” or “PLII MUSIC/MOVIE.”
- When using the SCART connection, be sure to follow the procedures in step 1 or noise may result. If noise continues after turning on the “TV” indicator, check the output setting of the connected TV or equipment. See the instructions supplied with the TV/equipment for details.

Other Operations

Enjoying the Radio

Connect the FM/AM aerials to the subwoofer (page 21) and preset radio stations.

Note

You cannot record FM/AM radio sound using the recorder or connected equipment.

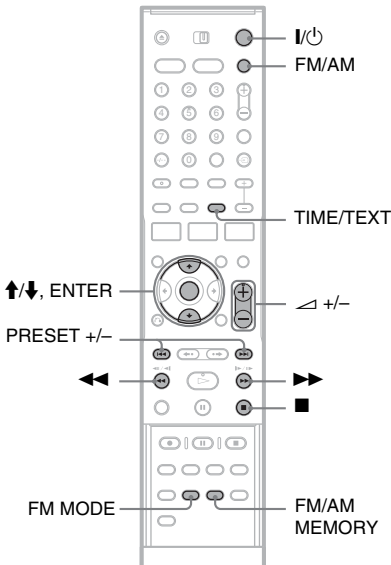

Presetting radio stations

You can preset 20 FM stations, and 10 AM stations. Before tuning, make sure to turn the volume down to minimum.

- 1 Press **I/⏻** to turn on the system.
- 2 Press **FM/AM** repeatedly to select FM or AM.
- 3 Press and hold **⬅️** or **➡️** until auto scanning starts.

Scanning stops when the system tunes in a station. "TUNED" and "ST" (for stereo programme) appear in the front panel display.



4 Press FM/AM MEMORY.

A preset number appears.

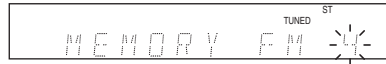

5 Press ⬆️/⬆️ to select the preset number you want.

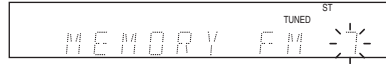

6 Press ENTER.

The station is stored.

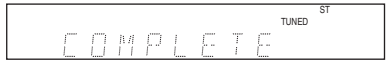

7 Repeat steps 2 to 6 to store other stations.

To change the preset number

Repeat the above steps and select a different preset number in step 5.

Listening to the radio

- 1 Press **I/⏻** to turn on the system.
- 2 Press **FM/AM** repeatedly to select FM or AM.

The last received station is tuned in.



3 Press PRESET +/- to select the preset station you want.

4 Press ⏪ (volume) +/- to adjust the volume.

To turn off the radio

Press **I/⏻** to turn off the system.

To listen to non-preset radio stations

Use manual or automatic tuning in step 3 above.

- To tune in a station manually, press **⬅️** or **➡️**.
 - To start auto tuning, press and hold **⬅️** or **➡️**.
- You can stop the scanning by pressing **■**.

If FM sound is noisy

Press FM MODE so that “MONO” appears in the front panel display. There will be no stereo effect, but reception will improve.

- To restore the stereo effect, press FM MODE again.

Hints

- You can also select a preset station using the number buttons and SET button.
- You can listen to the radio while the recorder is recording, dubbing, or standing by for a timer recording, but not while editing.
- When you select FM/AM during playback, playback stops.
- You cannot use the radio function when:
 - the system is in DVD mode or HDD mode.
 - the connected TV is used.
 - the subwoofer is not turned on or its mains lead is disconnected.

About the Radio Data System (RDS)

The Radio Data System (RDS) is a broadcasting service that allows radio stations to send additional information along with the regular broadcast signal. This tuner offers convenient RDS features, such as station name display. RDS is available only on FM stations*.

* Not all FM stations provide the RDS service, neither do they provide the same type of services. If you are not familiar with the RDS system, check with your local radio stations for details on RDS services in your area.

Note

RDS may not work properly if the station you are tuned to is not transmitting the RDS signal properly, or if the signal strength is weak.

To receive RDS broadcasts

Simply select a station from the FM band. When you tune in a station that provides RDS services, the station name* appears in the display. * If an RDS broadcast is not received, the station name may not appear in the display.

Hint

When a station name is displayed, you can check the frequency by pressing TIME/TEXT repeatedly.

Controlling TVs With the Remote

You can adjust the remote's signal to control your TV.

Notes

- Depending on the connected unit, you may not be able to control your TV with some or all of the buttons below.
- If you enter a new code number, the code number previously entered will be erased.
- When you replace the batteries of the remote, the code number may be reset to the default setting. Set the appropriate code number again.

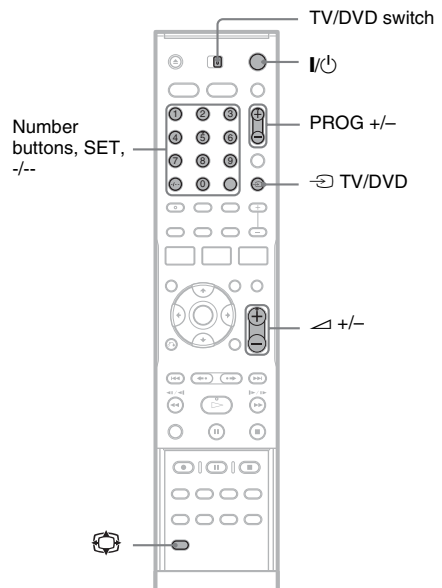

- 1** Slide the TV/DVD switch to TV.
- 2** Hold down I/⏻.
- 3** Enter your TV's manufacturer code (see “Code numbers of controllable TVs” below) using the number buttons.

4 Release I/⏻.

When the TV/DVD switch is set to TV, the remote performs the following:

Button	Operation
I/⏻	Turns your TV on or off
⏮ (volume) +/-	Adjusts the volume of your TV
↺ TV/DVD	Switches your TV's input source
PROG +/-	Selects the programme position on a Sony TV
Number buttons and SET, -/--.*	Selects the programme position on a Sony TV
⏻ (wide mode)	Switch to or from the wide mode of a Sony wide-screen TV.

* For two-digit numbers, if you use the number buttons to select the TV's programme position, press -/-- followed by the number buttons.

Manufacturer	Code number
Sharp	08
Thomson	11
Toshiba	10
JVC	09

To operate the ↺ TV/DVD button (for SCART connections only)

The ↺ TV/DVD button switches between the recorder and the last input source selected on the TV. Point your remote at the recorder when using this button. The button works even if the TV/DVD switch is set to DVD.

When you connect the recorder to the TV via the SCART jacks, the input source for the TV is set to the recorder automatically when you start playback. To watch another source, press the ↺ TV/DVD button to switch the TV's input source.

Code numbers of controllable TVs

If more than one code number is listed, try entering them one at a time until you find the one that works with your TV.

Manufacturer	Code number
Sony	01 (default)
Grundig	04
Hitachi	06
Panasonic	05, 12
Philips	02, 03
Samsung	13
Sanyo	07

Aerial Reception and Language Settings (Settings)

The “Settings” setup helps you make tuner, language, clock, and programme position settings for the recorder.

1 Press **HDD** or **DVD**, and press **SYSTEM MENU** while the recorder is in stop mode.

2 Select “**SETUP**,” and press **ENTER**.

3 Select “**Settings**,” and press **ENTER**.

The options of “Settings” appear. The default settings are underlined.

- To turn off the display, press **SYSTEM MENU** repeatedly.

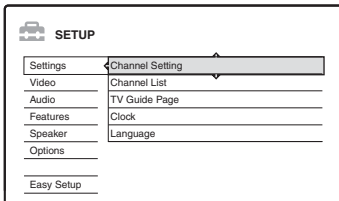

Channel Setting

Presets programme positions manually.

If some programme positions could not be set using the “Easy Setup” function, you can set them manually.

If there is no sound or if the picture is distorted, the wrong tuner system may have been preset during “Easy Setup.” Set the correct tuner system manually following the steps below.

1 Select “Channel Setting” in “Settings,” and press **ENTER**.

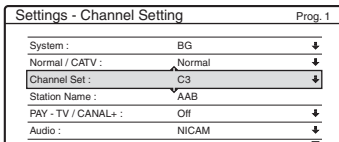

2 Press **PROG +/-** to select the programme position.

Selected programme position

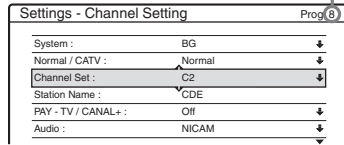

3 Select “System,” and press **ENTER**.

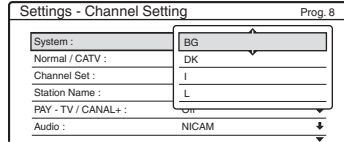

4 Select an available TV system, from **BG**, **DK**, **I**, or **L**, and press **ENTER** (page 91).

BG	Select this when in West European countries, except those listed in “Receivable channels” on page 91.
DK	Select this when in East European countries.
I	Select this when in Great Britain/Ireland.
L	Select this when in France.

5 Select “Normal/CATV,” and press **ENTER**.

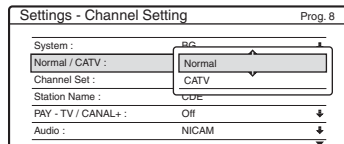

6 Select “Normal,” and press **ENTER**.

- To set **CATV** (Cable Television) channels, select “**CATV**.”

7 Select “Channel Set,” and press **ENTER**.

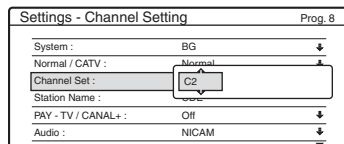

- 8 Press **↑/↓** repeatedly until the channel you want is displayed, then press **ENTER**. The channels are scanned in the order shown in the table below.

- If you know the number of the channel you want, press the number buttons. For example, for channel 5, first press “0” and then press “5.” Then press **ENTER**.

- 9 Select “Audio,” and press **ENTER**.

Settings - Channel Setting		Prog. 8
System :	BG	↓
Normal / CATV :	Normal	↓
Channel Set :	C5	↓
Station Name :	CDE	
PAY - TV / CANAL+ :	NICAM	
Audio :	Standard	

NICAM	Normally, select this.
Standard	Select this if the sound from NICAM broadcasts is not clear.

- 10 Select “NICAM,” and press **ENTER**.

- 11 Select “AFT” and press **ENTER**.

Settings - Channel Setting		Prog. 8
Normal / CATV :	Normal	↑
Channel Set :	C5	↓
Station Name :	CDE	
PAY - TV / CANAL+ :	On	
Audio :	On	
AFT :	Off	

On	Turns on the Auto Fine Tuning function. Normally, select this.
Off	Allows you to adjust the pictures manually.

- 12 Select “On” to turn on AFT, and press **ENTER**.

- If the Auto Fine Tuning function does not work effectively, select “Off” and press **ENTER**. When the fine tuning bar appears, press **←/→** to obtain a clearer picture, and press **ENTER**.
- To preset another channel, repeat from step 2.

◆Receivable channels

TV system	Channel coverage
BG (West European Countries, except those listed below)	E2 - E12 VHF
	Italia A - H VHF
	E21 - E69 UHF
	S1 - S20 CATV
	S21 - S41 HYPER
S01 - S05 CATV	
DK (East European Countries)	R1 - R12 VHF
	R21 - R69 UHF
	S1 - S20 CATV
	S21 - S41 HYPER
	S01 - S05 CATV
I (Great Britain/Ireland)	Ireland A - J VHF
	South Africa 4 - 13 VHF
	B21 - B69 UHF
	S1 - S20 CATV
	S21 - S41 HYPER
S01 - S05 CATV	
L (France)	F2 - F10 VHF
	F21 - F69 UHF
	B - Q CATV
	S21 - S41 HYPER

◆Tuning the French CATV channels

This recorder can scan the CATV channels B to Q and the HYPER frequency channels S21 to S41. On the Channel Set menu, the channels are indicated as S1 to S44. For example, channel B is indicated by Channel Set number S1, and channel Q is indicated by Channel Set number S23 (see the table below). If the CATV channel you want to preset is indicated by its frequency (for example, 152.75 MHz), refer to the table below to find the corresponding channel number.

Corresponding channel	Channel Set number	Receivable Frequency range (MHz)
B	S1	116.75-124.75
C	S2	124.75-132.75
D	S3	132.75-140.75
D	S4	140.75-148.75
E	S5	148.75-156.75

Corresponding channel	Channel Set number	Receivable Frequency range (MHz)
F	S6	156.75–164.75
F	S7	164.75–172.75
G	S8	172.75–180.75
H	S9	180.75–188.75
H	S10	188.75–196.75
I	S11	196.75–204.75
J	S12	204.75–212.75
J	S13	212.75–220.75
K	S14	220.75–228.75
L	S15	228.75–236.75
L	S16	236.75–244.75
M	S17	244.75–252.75
N	S18	252.75–260.75
N	S19	260.75–268.75
O	S20	268.75–276.75
P	S21	276.75–284.75
P	S22	284.75–292.75
Q	S23	292.75–300.75
S21	S24	299.25–307.25
S22	S25	307.25–315.25
S23	S26	315.25–323.25
S24	S27	323.25–331.25
S25	S28	331.25–339.25
S26	S29	339.25–347.25
S27	S30	347.25–355.25
S28	S31	355.25–363.25
S29	S32	363.25–371.25
S30	S33	371.25–379.25
S31	S34	379.25–387.25
S32	S35	387.25–395.25
S33	S36	395.25–403.25
S34	S37	403.25–411.25
S35	S38	411.25–419.25
S36	S39	419.25–427.25
S37	S40	427.25–435.25
S38	S41	435.25–443.25

Corresponding channel	Channel Set number	Receivable Frequency range (MHz)
S39	S42	443.25–451.25
S40	S43	451.25–459.25
S41	S44	459.25–467.25

Station Name

Changes or enters a new station name (up to 5 characters). The recorder must receive channel information (for instance, SMARTLINK information) for station names to appear automatically.

- 1 Select “Channel Setting” in “Settings,” and press ENTER.

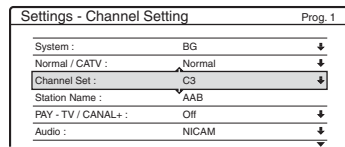

- 2 Press PROG +/- to select the programme position for which you want to change or enter a station name.
- 3 Select “Station Name,” and press ENTER. The display for entering characters appears.

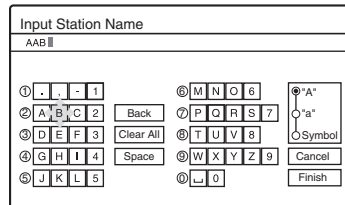

- To enter characters, see page 43.

- 4 Select “Finish,” and press ENTER.

PAY-TV/CANAL+

Sets the PAY-TV/Canal Plus channels. For details, see page 33.

Channel List (Changing/Disabling the channels)

Changes or disables the programme positions after setting the channels. If any programme positions are unused or contain unwanted channels, you can disable them.

You can also change station names. If the station names are not displayed, you can enter them manually.

- 1 Select "Channel List" in "Settings," and press ENTER.

Settings - Channel List		
Prog	Channel	Name
1	C3	AAB
2	C5	FGH
3	C12	
4	C21	
5	C23	
6	C24	PCR

- 2 Press \uparrow/\downarrow to select the row containing the programme position you want to change or disable.
 - To change, press ENTER and go to step 3.
 - To disable, press CLEAR and go to step 5. The disabled positions will be skipped when you press PROG +/-.

- To display other pages for programme positions 7 to 99, press \uparrow/\downarrow repeatedly.

- 3 Press \uparrow/\downarrow until the selected channel row moves to the desired programme position. The selected channel is inserted at the new programme position.

Settings - Channel List		
Prog	Channel	Name
1	C3	AAB
2	C12	
3	C21	
4	C5	FGH
5	C23	
6	C24	PCR

- 4 Press ENTER to confirm the setting.
- 5 To change or disable the programme position of another station, repeat from step 2.

Note

Be sure to correctly select the programme position you want to disable. If you disable the wrong programme position by mistake, you will need to reset that channel manually.

TV Guide Page

Some broadcast systems ensure a Teletext service* in which the complete programmes and their data (title, date, channel, recording start time, etc.) are stored day by day. A TV guide page corresponds to each day of the week. When recording a programme, the recorder automatically takes the programme name from the Teletext pages and stores it as the title name. The TV guide page numbers depend entirely on the broadcast itself and may be subject to change. Therefore, you may have to set those TV guide page numbers manually in the TV Guide Page menu.

* Not available in some areas.

- 1 Select "TV Guide Page" in "Settings," and press \rightarrow or ENTER. The TV Guide Page menu appears.
 - 2 Select the programme position for which you want to set or change the TV guide page by pressing PROG +/-.
- The TV guide page numbers (Example: P301) appear automatically when the recorder detects them.

Settings - TV Guide Page		Prog. 4
Sun	P 301	\downarrow
Mon	P 302	\downarrow
Tue	P 303	\downarrow
Wed	P 304	\downarrow
Thu	P 305	\downarrow
Fri	P 306	\downarrow
Sat	P 307	\downarrow

- If no page numbers are detected (P000), you have to set the appropriate TV guide page number manually.

Settings - TV Guide Page		Prog. 4
Sun	P 000	\downarrow
Mon	P 000	\downarrow
Tue	P 000	\downarrow
Wed	P 000	\downarrow
Thu	P 000	\downarrow
Fri	P 000	\downarrow
Sat	P 000	\downarrow

- 3 Select the TV guide page number you want to modify, and press ENTER.

Settings - TV Guide Page		Prog. 4
Sun	P 000	\downarrow
Mon	P 000	\downarrow
Tue	P 000	\downarrow
Wed	P 000	\downarrow
Thu	P 000	\downarrow
Fri	P 000	\downarrow
Sat	P 000	\downarrow

- 4 Press the number buttons or $\leftarrow/\uparrow/\downarrow/\rightarrow$ to enter the TV guide page number, and press ENTER to confirm the setting.
- If you make a mistake, press CLEAR to re-enter the correct number.
 - To set or change another TV guide page number, repeat steps 3 and 4 above.

Hint

To view Teletext information on your TV screen during a broadcast, switch to your TV's tuner by pressing \square TV/DVD.

Notes

- In step 4 above, enter "000" if you do not want to use the TV guide page number for automatic labelling. The recorder will instead store a default title name (programme position, start time - stop time).
- Refer to the Teletext information on your TV screen to obtain the TV guide page number with programme titles and their start times.
- If the Teletext TV guide has a page which always shows the programmes for the current day, this page should be input for all days.
- If you start recording more than three minutes before the programme is scheduled to start, the correct label information may not be transferred.
- Note that this function may not work correctly with programmes broadcast from some stations.
- If the broadcast system updates the Teletext information at the moment recording starts, the title label may not correspond to the recorded programme. In this case, you may have to manually enter the correct title (page 43).

Clock

Auto Adjust

Turns on the Auto Clock Set function when a channel in your local area broadcasts a time signal.

- 1 Select "Clock" in "Settings," and press ENTER.
- 2 Select "Auto Adjust," and press ENTER.

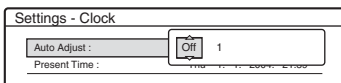

- 3 Select "On," and press \rightarrow .

- 4 Press \uparrow/\downarrow repeatedly until the programme position of the station that carries a time signal appears, and press ENTER.

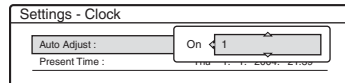

- If the recorder does not receive a time signal from any station, "Auto Adjust" returns to "Off" automatically and the menu for setting the clock manually appears on the screen.

Hint

If you set "Auto Adjust" to "On," the Auto Clock Set function is activated whenever the recorder is turned off.

Note

The Auto Clock Set function does not work while the recorder is standing by for Synchro-Recording.

◆To set the clock manually

If the Auto Clock Set function did not set the clock correctly for your local area, try another station or set the clock manually.

- 1 Select "Clock" in "Settings," and press ENTER.
- 2 Select "Auto Adjust," and press ENTER.

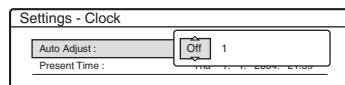

- 3 Select "Off," and press ENTER.
- 4 Select "Present Time," and press ENTER.

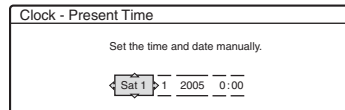

- 5 Press \uparrow/\downarrow to set the day, and press \rightarrow . Set the month, year, hour, and minutes in sequence. Press \leftarrow/\rightarrow to select the item to be set, then press \uparrow/\downarrow to set the numbers. The day of the week is set automatically.

- To change the numbers, press \leftarrow to return to the item to be changed, and press \uparrow/\downarrow .

- 6 Press ENTER to start the clock.

Language

OSD (On-Screen Display)

Switches the display language on the screen.

DVD Menu (DVD VIDEO only)

Switches the language for the DVD menu.

Audio (DVD VIDEO only)

Switches the language of the soundtrack.

When you select “Original,” the language given priority in the disc is selected.

Subtitle (DVD VIDEO only)

Switches the language of the subtitles recorded on the disc.

When you select “Audio Follow,” the subtitle language changes according to the language you selected for the soundtrack.

Hint

If you select “Others” in “DVD Menu,” “Subtitle,” or “Audio,” select and enter a language code from “Language Code List” (page 123) using the number buttons.

Note

If you select a language in “DVD Menu,” “Subtitle,” or “Audio” that is not recorded on the DVD VIDEO, one of the recorded languages will be automatically selected.

Video Settings (Video)

Video settings will adjust items related to the image, such as size and colour.

Choose the settings according to the type of TV, tuner, or decoder connected to the DVD recorder.

1 Press **SYSTEM MENU** while the recorder is in stop mode.

2 Select “**SETUP**,” and press **ENTER**.

3 Select “**Video**,” and press **ENTER**.

The “Video” setup appears with the following options. The default settings are underlined.

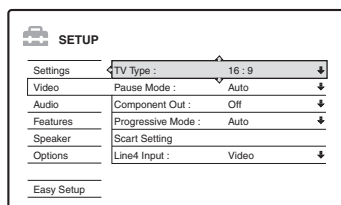

TV Type

Sets the picture size when playing back a title recorded from a 16:9 size video (page 54) or a 16:9 size commercial DVD VIDEO.

Select the playback picture size according to the type of connected TV (wide-screen/wide mode TV or conventional 4:3 screen TV).

<u>16:9</u>	Select this when connecting to a wide-screen TV or TV with a wide mode function.
4:3 Letter Box	Select this when connecting to a 4:3 screen TV. Displays a wide picture with bands on the upper and lower portions of the screen.
4:3 Pan Scan	Select this when connecting to a 4:3 screen TV. Automatically displays a wide picture on the entire screen and cuts off the portions that do not fit.

16:9

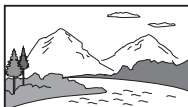

4:3 Letter Box



4:3 Pan Scan

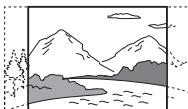

Note

Depending on the disc, “4:3 Letter Box” may be selected automatically instead of “4:3 Pan Scan” or vice versa.

Pause Mode (HDD/DVDs only)

Selects the picture quality in pause mode.

<u>Auto</u>	The picture, including subjects that move dynamically, is output with no jitter. Normally, select this position.
Frame	The picture, including subjects that do not move dynamically, is output in high resolution.

Component Out

Selects whether or not to output video signals from the COMPONENT VIDEO OUT jacks.

<u>On</u>	Outputs the component video signals. Select this when you want to view progressive signals.
<u>Off</u>	Outputs no signals.

Notes

- When you set “Line1 Output” to “RGB,” you cannot set “Component Out” to “On.”
- When you connect the recorder to a monitor or projector via only the COMPONENT VIDEO OUT jacks, do not select “Off.” If you select “Off” in this case, the picture may not appear.

Progressive Mode

DVD software can be divided into two types: film based software and video based software. Video based software is derived from TV, such as dramas and sit-coms, and displays images at 30 frames/60 fields (25 frames/50 fields) per second. Film based software is derived from film and displays images at 24 frames per second. Some DVD software contains both Video and Film.

In order for these images to appear natural on your screen when output in PROGRESSIVE mode (50 or 60 frames per second), the progressive video signal needs to be converted to match the type of DVD software that you are watching.

You can fine-tune the progressive 525p/625p video signal that is output when you press PROGRESSIVE (“PROGRE” lights up). Note that you must connect to a progressive format TV using the COMPONENT VIDEO OUT jacks (page 26).

<u>Auto</u>	Automatically detects the software type (Film-based or Video-based) and selects the appropriate conversion mode. Normally, select this position.
Video	Fixes the conversion mode to the mode for Video-based software.

Scart Setting

Sets the method of inputting/outputting signals from the SCART jacks on the rear panel of the recorder. Select an option for each of the items below according to the combination of jacks and methods that you are going to use.

◆Line1 Output

Selects a method of outputting video signals for the LINE 1 – TV jack.

RGB	Outputs RGB signals.
<u>Video</u>	Outputs video signals.
S Video	Outputs S-video signals.

Notes

- If your TV does not accept S-video or RGB signals, no picture appears on the TV screen even if you select “S Video” or “RGB.” See the instructions supplied with your TV.
- You cannot select “RGB” when “Component Out” above is set to “On.”
- SMARTLINK is available only when “Video” is selected.

◆Line3 Input

Selects a method of inputting video signals for the LINE 3/DECODER jack. The picture will not be clear if this setting does not match the type of video input signal.

<u>Video/RGB</u>	Inputs video signals or RGB signals.
Decoder	Select this when connecting to a PAY-TV/Canal Plus decoder.
S Video	Inputs S-video signals.

◆Line3 Output

Selects a method of outputting video signals for the LINE 3/DECODER jack.

<u>Video</u>	Outputs video signals.
S Video	Outputs S-video signals.

Line4 Input

Selects a method of inputting video signals for the LINE 4 IN jack on the rear panel of the recorder.

<u>Video</u>	Inputs video signals.
S Video	Inputs S-video signals.

Audio Settings (Audio)

The “Audio” setup allows you to adjust the sound according to the playback conditions.

- 1 Press **SYSTEM MENU** while the recorder is in stop mode.
- 2 Select “**SETUP**,” and press **ENTER**.
- 3 Select “**Audio**,” and press **ENTER**.

The “Audio” setup appears with the following options. The default setting is underlined.

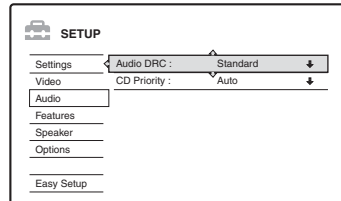

Audio DRC (Dynamic Range Control) (DVDs only)

Makes the sound clear when the volume is turned down when playing a DVD that conforms to “Audio DRC.”

<u>Off</u>	No compression of dynamic range.
Standard	Reproduces the soundtrack with the dynamic range intended by the recording engineer.
Max	Maximum compression of dynamic range.

Note

The Audio DRC function works for Dolby Digital sources only.

CD Priority

<u>Auto</u>	Plays DTS tracks on a CD. Since the recorder automatically selects the bit stream, beginnings may be skipped depending of the track. If you want to avoid this, select "PCM."
PCM	Plays CDs with no skipping. Since this option does not allow for bit steam selection, only noise will be output when you play DTS tracks on a CD. To play DTS CDs, select "Auto."

Recording and Parental Control Settings (Features)

The "Features" setup allows you to adjust recording and parental control settings.

- 1** Press **SYSTEM MENU** while the recorder is in stop mode.
- 2** Select "**SETUP,**" and press **ENTER.**
- 3** Select "**Features,**" and press **ENTER.**

The "Features" setup appears with the following options. The default settings are underlined.

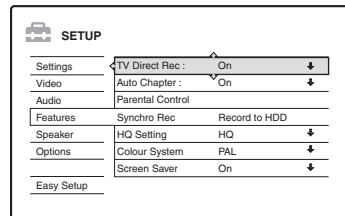

TV Direct Rec (HDD/DVD+RW/DVD-RW/ DVD+R/DVD-R only)

<u>On</u>	Allows you to easily record what you are watching on the TV using SMARTLINK.
Off	Turns off the TV Direct Rec function.

Auto Chapter

Selects whether to automatically divide a recording (a title) into chapters during recording or dubbing.

<u>On</u>	For the HDD or a DVD-RW (VR mode), the recorder detects changes in the picture and sound and automatically inserts chapter marks. For other recordable discs, the recorder inserts chapter marks at approximately 6-minute intervals.
Off	No chapter mark is inserted.

Note

The actual chapter mark interval may vary depending on the amount of information contained in the video to be recorded.

Parental Control (DVD VIDEO only)

Playback of some DVD VIDEOS can be restricted according to a predetermined level, such as the age of the users. Scenes may be blocked or replaced with different scenes.

- 1 Select "Parental Control" in "Features," and press ENTER.
 - If you have not entered a password, the display for registering a new password appears.

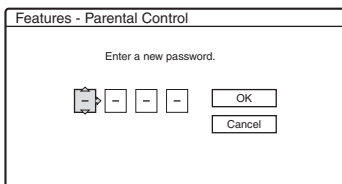

- When you have already registered a password, the display for entering the password appears.

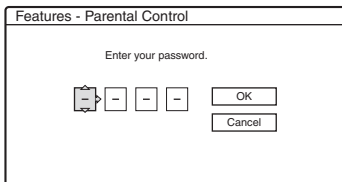

- 2 Enter your four-digit password using the number buttons, then select "OK" and press ENTER.

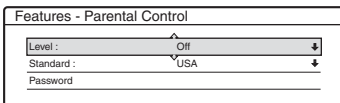

- 3 Select "Standard," and press → or ENTER. The selection items for "Standard" are displayed.

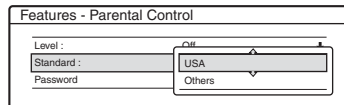

- 4 Select a geographic area as the playback limitation level, and press ENTER. The area is selected.

- When you select "Others," press the number buttons to select and enter an area code in the table (page 123). Then select "OK" and press ENTER.

- 5 Select "Level," and press ENTER. The selection items for "Level" are displayed.

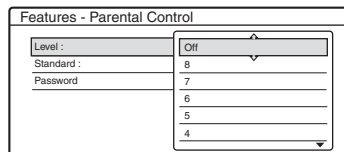

The lower the value, the stricter the limitation. Discs rated higher than the selected level will be restricted.

- 6 Select the level, and press ENTER. The Parental Control setting is complete.

- To cancel the Parental Control setting for the disc, set "Level" to "Off" in step 6.
- To change the password, select "Password" in step 3, and press ENTER. When the display for registering a password appears, enter a new four-digit password using the number buttons, then select "OK" and press ENTER.

Notes

- If you forget your password, you will have to reset it by selecting "Parental Control" of "Factory Setup" in "Options" setup (page 104).
- When you play discs which do not have the Parental Control function, playback cannot be limited on this recorder.
- Depending on the disc, you may be asked to change the Parental Control level while playing the disc. In this case, enter your password, then change the level.

Synchro Rec

Selects the recording destination used for Synchro-Recording (page 57).

<u>Record to HDD</u>	Records to the HDD.
Record to DVD	Records to DVDs.

HQ Setting (HDD only)

Selects the HQ mode used for recording on the HDD (page 48).

HQ+	Records in higher quality (approximate 15 Mbps).
<u>HQ</u>	Records in the standard HQ mode.

Colour System

Selects the colour system when playing VIDEO CDs (including Super VIDEO CDs).

<u>PAL</u>	Plays a disc in PAL colour system.
NTSC	Plays a disc in NTSC colour system.

Screen Saver

The screen saver image appears when you do not use the recorder for more than 10 minutes while an on-screen display, such as the System Menu, is displayed on your TV screen. The screen saver image helps prevent your display device from becoming damaged (ghosting).

<u>On</u>	Turns on the screen saver function.
Off	Turns off the function.

Speaker Settings (Speaker)

The “Speaker” setup allows you to adjust the speaker system (speaker positions, loudness, etc.).

Note

Check that the subwoofer is turned on, and that the system cord is connected securely.

- 1 Press **SYSTEM MENU** while the recorder is in stop mode.
- 2 Select **“SETUP,”** and press **ENTER**.
- 3 Select **“Speaker,”** and press **ENTER**.
The “Speaker” setup appears.

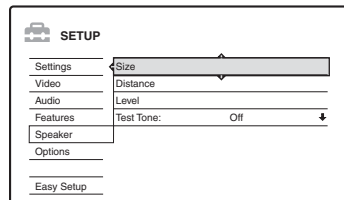

- 4 Select an item.
“Size”: Selects the surround speaker position, etc. (page 101).
“Distance”: Sets the speaker distance from the listening position (page 101).
“Level”: Sets the speaker level (page 102).
“Test Tone”: Emits the test tone for adjusting the individual speaker levels (page 102).
- 5 Press **ENTER**.
Options for the selected item appear (see below). The default settings are underlined.
- 6 Select an option, and press **ENTER**.

Size

Selects the surround speaker position and whether to engage the speakers.

Front

<u>Yes</u>	Fixed setting.
------------	----------------

Center

<u>Yes</u>	Normally, select this.
None	Select this if no centre speaker is used.

Surround

<u>Behind</u>	Select this if the surround speakers are located in B .
Side	Select this if the surround speakers are located in A .
None	Select this if no surround speaker is used.

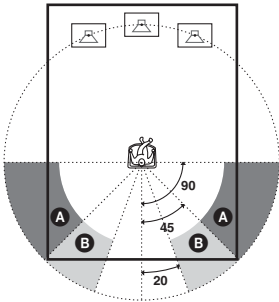

Subwoofer

<u>Yes</u>	Fixed setting.
------------	----------------

Distance

Set the distance from your listening position to the front speakers in “Front” (front speaker) first (**A**). Then adjust the values in “Center” (centre speaker) (**B**) and “Surround” (surround speaker) (**C**). For speaker placement, see page 16.

Notes

- The settings below may not be the defaults if you followed the “Room Size” setup of “Step 8: Easy Setup” (page 34) to reflect the current speaker placement.
- Change your current settings again should you change the speaker positions.

Front

Set the front speaker distance within 1.0 to 7.0 m (set in 0.2 m increments). The default setting is “1.6.”

Center

Set the centre speaker distance between the “Front” setting and -1.6 m of the “Front” setting (set in 0.2 m increments). The default setting is “1.6.”

Surround

Set the surround speaker distance between the “Front” setting and -4.6 m of the “Front” setting. (set in 0.2 m increments). The default setting is “1.6.”

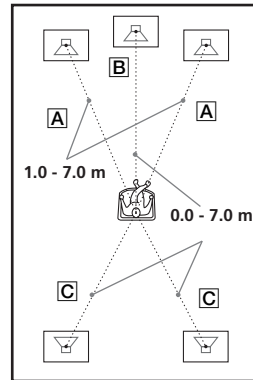

Notes

- When you select an item, sound momentarily cuts off.
- If front and surround speakers are not placed at an equal distance from your listening position, set the distance according to the closest speaker.
- Do not place the surround speakers farther away from your listening position than the front speakers.
- Depending on the input signal, the distance settings may not be effective.

Level

Sets the loudness of each speaker individually. Use the test tone for easy adjustment (see “Test Tone” on page 102).

To adjust the volume of all the speakers at one time, press \triangleleft +/-.

Front Left

Set the front left speaker level within -6.0 and 0.0 (set in 1 dB increments). The default setting is “0.0.”

Center

Set the centre speaker level within -6.0 and 6.0 (set in 1 dB increments). The default setting is “0.0.”

Front Right

Set the front right speaker level within -6.0 and 0.0 (set in 1 dB increments). The default setting is “0.0.”

Surround Right

Set the surround right speaker level within -6.0 and 6.0 (set in 1 dB increments). The default setting is “0.0.”

Surround Left

Set the surround left speaker level within -6.0 and 6.0 (set in 1 dB increments). The default setting is “0.0.”

Subwoofer

Set the subwoofer level within -6.0 and 6.0 (set in 1 dB increments). The default setting is “0.0.”

Test Tone

Set the speaker levels by using the test tone.

- 1 Press SYSTEM MENU while the recorder is in stop mode.
- 2 Select “SETUP,” and press ENTER.
- 3 Select “Speaker,” and press ENTER. The “Speaker” setup appears.

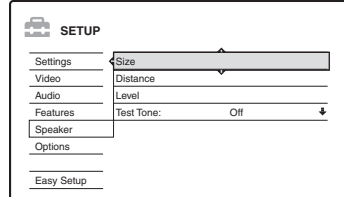

- 4 Select “Test Tone” and press ENTER.

<u>Off</u>	Emits no test tone.
On	Emits the test tone from the speakers in sequence.

- 5 Select “On,” and press ENTER.
- 6 Select “Level,” and press ENTER.
- 7 Select the speaker you want to adjust; “Front Left,” “Center,” “Front Right,” “Surround Right,” “Surround Left,” or “Subwoofer,” and press ENTER. The selected speaker emits the test tone.
- 8 From your listening position, adjust the speaker level by pressing \uparrow/\downarrow and ENTER.
- 9 Repeat steps 7 and 8 to adjust the other speaker levels.
- 10 When you finish adjusting levels, repeat the above steps to select “Off” in step 5. The test tone stops.
- 11 Press SYSTEM MENU to turn off the menu.

Note

When you adjust the speaker settings, sound momentarily cuts off.

Disc Settings/Factory Settings (Options)

The “Options” setup allows you to set up other operational settings.

1 Press **SYSTEM MENU** while the recorder is in stop mode.

2 Select “**SETUP**,” and press **ENTER**.

3 Select “**Options**,” and press **ENTER**.

The “Options” setup appears with the following options. The default settings are underlined.

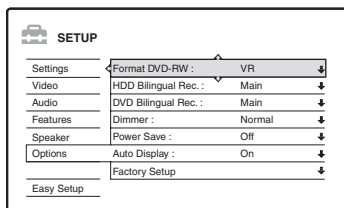

Format DVD-RW (DVD-RW only)

When a new unformatted DVD-RW is inserted, the recorder automatically starts formatting in VR mode or Video mode, whichever is selected below.

<u>VR</u>	Automatically formats the disc in VR mode.
Video	Automatically formats the disc in Video mode.

HDD Bilingual Rec. (HDD only)

Selects the sound to be recorded on the HDD.

<u>Main</u>	Records the main sound for the bilingual programme.
Sub	Records the sub sound for the bilingual programme.
Main+Sub	Records the main and sub sounds for the bilingual programme.

Note

If you set the recording mode to be changed while dubbing from a DVD to the HDD, the sound recorded in the source (DVD) is applied regardless of this setting.

DVD Bilingual Rec. (for all recordable discs except DVD-RW in VR mode)

Selects the sound to be recorded on the recordable disc. This setting is not necessary when recording on DVD-RWs (VR mode) that record both the main and sub sounds.

<u>Main</u>	Records the main sound for the bilingual programme.
Sub	Records the sub sound for the bilingual programme.

Dimmer

Adjusts the lighting of the front panel display.

<u>Normal</u>	Bright lighting.
Power Save	Low lighting. Turns off the lighting when the power is off.

Note

When “Power Save” in “Options” setup is set to “On,” the front panel display is turned off during standby regardless of this setting.

Power Save

Selects whether this recorder is in power save mode when the power is turned off (standby).

On	Sets to power save mode. The front panel display is off when the recorder is in standby.
<u>Off</u>	Does not set to power save mode. Normally, select this.

Note

Power Save mode does not function in the following cases, even when “Power Save” is set to “On.”

- Synchro Recording is set.
- There is a timer setting with “PDC/VPS” set to “On” in the Timer List.

Auto Display

On	Automatically displays information on the screen when the recorder is turned on, etc.
Off	Displays information only when DISPLAY is pressed.

Factory Setup

Allows you to select the setup settings by group, and return them to their default settings. Note that all of your previous settings will be lost.

- 1 Select “Factory Setup” in “Options,” and press **➡** or ENTER.
The display for selecting a group of settings appears.
- 2 Select the group of settings you want to return to default from “Settings,” “Video,” “Audio,” “Features,” “Speaker,” “Options,” “Parental Control,” and “All,” and press **➡** or ENTER.
- 3 Select “Start,” and press ENTER.
The selected settings return to their default settings.
- 4 Press ENTER when “Finish” appears.

Note

The “All” setting also returns the following settings to their defaults:

- Preset numbers for radio stations.
- DSGX setting.
- Volume setting.
- Sound Field setting.

Easy Setup (Resetting the System)

Select this to run the “Easy Setup” programme.

- 1 Press **SYSTEM MENU** while the recorder is in **stop mode**.
- 2 Select **“SETUP,”** and press **ENTER**.
- 3 Select **“Easy Setup,”** and press **ENTER**.

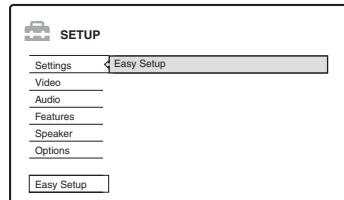

- 4 Press **ENTER**.
- 5 Select **“Start.”**
- 6 Follow the instructions for **“Step 8: Easy Setup”** (page 34) from step 2.

Troubleshooting

If you experience any of the following difficulties while using the recorder, use this troubleshooting guide to help remedy the problem before requesting repairs. Should any problem persist, consult your nearest Sony dealer.

When bringing the system in for repairs, be sure to bring in the entire system.

This product is a system product, and the entire system is needed to determine the location requiring repair.

Power

The power does not turn on.

- ➔ Check that the mains leads are connected securely.
- ➔ The system cord is not connected securely (page 22).
Disconnect the subwoofer mains lead, and then reconnect the mains lead after about two minutes.

ON/STANDBY indicator on the subwoofer flashes.

- ➔ Unplug the subwoofer mains immediately, and make sure that:
 - The speaker cords are not short circuited.
 - Only the specified speakers are used.
 - The ventilation holes are not blocked.When all of the above are confirmed, wait about two minutes until the indicator turns off, reconnect the subwoofer mains lead, and then turn on the speaker system. If the indicator still flashes, consult your nearest Sony dealer.

Picture

There is no picture.

- ➔ Re-connect all connecting cords securely.
- ➔ The connecting cords are damaged.
- ➔ Check the connection to your TV (page 24).
- ➔ Switch the input selector on your TV (such as to “VCR”) so that the signal from the recorder appears on the TV screen.
- ➔ Check that “Scart Setting” in “Video” setup is set to the appropriate item that conforms to your system (page 96).
- ➔ If you connect the recorder to your TV via only the COMPONENT VIDEO OUT jacks, set “Component Out” in “Video” setup to “On” (page 96).
- ➔ This recorder cannot record NTSC signals.

Picture noise appears.

- ➔ If the picture output signal from your recorder passes through your VCR to get to your TV, or if you are connected to a combination TV/DVD player, the copy-protection signal applied to some DVD programmes could affect picture quality. If you still experience this problem even when you connect your recorder directly to your TV, try connecting your recorder to your TV’s S VIDEO input.
- ➔ You have set the recorder to progressive format (the “PROGRE” indicator lights up) even though your TV cannot accept the progressive signal. In this case, press PROGRESSIVE until the “PROGRE” indicator turns off.
- ➔ Even if your TV is compatible with progressive format (525p/625p) signals, the image may be affected when you set the recorder to progressive format. In this case, press PROGRESSIVE so that the “PROGRE” indicator turns off and the recorder is set to normal (interlace) format.
- ➔ You are playing a DVD recorded in a colour system that is different from your TV.
- ➔ Noise may appear in pictures recorded on the HDD. This is due to the characteristics of the HDD, and is not a malfunction.
- ➔ If the SCART connection is used, press  TV/DVD repeatedly to turn on “TV” in the front panel display, and then press INPUT SELECT to switch to an input other than LINE 1 and LINE 3. If noise continues, check the output setting of the TV. See the TV’s operating instructions for details.

TV programme reception does not fill the screen.

- ➔ Set the channel manually in “Channel Setting” in “Settings” setup (page 90).
- ➔ Select the correct source using the INPUT SELECT button, or select a channel of any TV programme using the PROG +/- buttons.

TV programme pictures are distorted.

- ➔ Reorient the TV aerial.
- ➔ Adjust the picture (see the TV’s instruction manual).
- ➔ Place the recorder and TV farther apart.
- ➔ Place the TV and any bunched aerial cables farther apart.
- ➔ The RF cable is connected to the AERIAL OUT jack on the recorder. Connect the cable to the AERIAL IN jack.

TV channels cannot be changed.

- ➔ The channel is disabled (page 93).
- ➔ A timer recording started, causing the channel to change.

The picture from equipment connected to the recorder’s input jack does not appear on the screen.

- ➔ If the equipment is connected to the LINE 1 – TV jack, select “L1” in the front panel display by pressing PROG +/- or INPUT SELECT.
If the equipment is connected to the LINE 2 IN jacks, select “L2” in the front panel display by pressing PROG +/- or INPUT SELECT.
If the equipment is connected to the LINE 4 IN jacks, select “L4” in the front panel display by pressing PROG +/- or INPUT SELECT.
If the equipment is connected to the LINE 3/ DECODER jack, select “L3” in the front panel display by pressing PROG +/- or INPUT SELECT.
- ➔ When an S video cable is connected to the recorder’s LINE 4 IN jack, set “Line4 Input” in “Video” setup to “S Video” (page 97).

The playback picture or TV programme from the equipment connected through the recorder is distorted.

- ➔ If the playback picture output from a DVD player, VCR, or tuner goes through your recorder before reaching your TV, the copy-protection signal applied to some programmes could affect picture quality. Disconnect the playback equipment in question and connect it directly to your TV.

The picture does not fill the screen.

- ➔ Set “TV Type” in “Video” setup in accordance with the screen size of your TV (page 95).

The picture does not fill the screen, even though the picture size is set in “TV Type” in “Video” setup.

- ➔ The picture size of the title is fixed.

The picture is black and white.

- ➔ Check that “Line1 Output” of “Scart Setting” in “Video” setup is set to the appropriate item that conforms to your system (page 96).
- ➔ If you are using a SCART cord, be sure to use one that is fully wired (21 pins).

Sound

There is no sound.

- ➔ Re-connect all connections securely.
- ➔ The connecting cord is damaged.
- ➔ The recorder is in reverse play, fast-forward, slow motion, or pause mode.
- ➔ Press MUTING if “MUTING ON” appears in the front panel display.
- ➔ Check the speaker settings (pages 14, 100).
- ➔ The LINE jacks do not output the audio signals of DTS soundtracks on a CD/DVD. You can hear the DTS sound from this speaker system only.

Sound is noisy.

- ➔ If the speaker system outputs noise when playing DTS soundtracks on a CD, set “CD Priority” in “Audio” setup to “Auto” (page 98).
- ➔ Clean the disc.
- ➔ If the SCART connection is used, press  TV/DVD repeatedly to turn on “TV” in the front panel display, and then press INPUT SELECT to switch to an input other than LINE 1 and LINE 3. If noise continues, check the output setting of the connected TV or equipment. See the instructions supplied with the TV/equipment.

Severe hum or noise is heard.

- ➔ Check that the speakers and components are connected securely.
- ➔ Check that the connecting cords are not too close to a transformer or motor, and at least three metres away from your TV set or any fluorescent lighting.
- ➔ Move your TV away from the system.
- ➔ The plugs and jacks are dirty. Wipe them with a cloth slightly moistened with alcohol.

The sound volume is low.

- ➔ The sound volume is low on some DVDs. The sound volume may improve if you set “Audio DRC” in “Audio” setup to “Max” (page 97).

An alternate audio track cannot be recorded.

- ➔ When recording from connected equipment, set “Line Audio Input” in the TOOLS menu to “Bilingual” (page 59).
- ➔ Multilingual tracks (main and sub) cannot be recorded on DVD+RWs, DVD-RWs (Video mode), DVD+Rs, or DVD-Rs. To record the language, select “Main” or “Sub” of “DVD Bilingual Rec.” in “Options” setup before recording (page 103). To record both the main and sub sounds, record on a DVD-RW (VR mode).
- ➔ Any discs other than the HDD or DVD-RWs (VR mode) cannot be used for recording both main and sub sounds. To record on the HDD, set “HDD Bilingual Rec.” in “Options” setup to “Main+Sub” (page 103).

The sound loses stereo effect when you play a DVD+RW, DVD+R, DVD-RW, DVD-R or VIDEO CD.

- ➔ Select a stereo audio track by pressing  (audio) (page 62).
- ➔ Make sure the system is connected properly.

The surround effect of the speaker system is difficult to hear when Dolby Digital or DTS audio soundtrack is played.

- ➔ Make sure the Sound Field function is on (page 84).
- ➔ Check the speaker connections and settings (page 14, 100).
- ➔ Depending on the disc, the output signal may not contain all of the 5.1 channels. Or, the track may be either monaural or stereo even when recorded in Dolby Digital format.

The left and right sounds are unbalanced or reversed.

- ➔ Check that the speakers and the components are connected correctly and securely.

The sound comes from the centre speaker only.

- ➔ Depending on the disc, the sound may come from the centre speaker only.

No sound is heard from the centre speaker.

- ➔ Check the speaker connections and settings (page 14, 100).
- ➔ Make sure the Sound Field function is on (page 84).
- ➔ Depending on the source, the effect of the surround speakers may be less noticeable.

No sound or only a very low-level sound is heard from the surround speakers.

- ➔ Check the speaker connections and settings (page 14, 100).
- ➔ Make sure the Sound Field function is on (page 84).
- ➔ Depending on the source, the effect of the surround speakers may be less noticeable.

Radio stations cannot be tuned in.

- ➔ Check that the FM/AM aerial is connected securely. Adjust the aerial or connect an external aerial, if necessary.
- ➔ The reception is poor. Try manual tuning (page 87).
- ➔ No stations have been preset or the preset stations have been cleared (when tuning by scanning preset stations). Preset the stations (page 87).
- ➔ Press TIME/TEXT so that the frequency appears in the front panel display.
- ➔ Keep the AM aerial away from the system and other equipment (recorder, subwoofer, TV, etc.).

Playback**The recorder does not play any type of disc (except HDD).**

- ➔ The disc is upside down. Insert the disc with the labelled side facing up.
- ➔ The disc is not correctly inserted.
- ➔ Moisture has condensed inside the recorder. Remove the disc and leave the recorder turned on for about half an hour until the moisture evaporates.
- ➔ If the disc was recorded on another recorder, the recorder cannot play the disc if it was not finalized (page 46).

The recorder does not start playback from the beginning.

- ➔ Resume play was activated (page 61).
- ➔ You have inserted a DVD whose Title menu or DVD menu automatically appears on the TV screen when it is first inserted. Use the menu to start playback.

The recorder starts playing automatically.

- ➔ The DVD VIDEO features an auto playback function.

Playback stops automatically.

- ➔ If the DVD has an auto pause signal, the recorder stops playback at the auto pause signal.

Some functions such as Stop, Search, or Slow-motion Play cannot be performed.

- ➔ Depending on the DVD, you may not be able to do some of the operations above. See the instruction manual supplied with the disc.

The language for the soundtrack cannot be changed.

- ➔ Multilingual tracks are not recorded on the DVD being played.
- ➔ The DVD VIDEO prohibits the changing of the language for the soundtrack.
- ➔ Try changing the language using the DVD VIDEO's menu.

The subtitle language cannot be changed or turned off.

- ➔ Multilingual subtitles are not recorded on the DVD VIDEO.
- ➔ The DVD VIDEO prohibits changing of the subtitles.
- ➔ Try changing the subtitle using the DVD VIDEO's menu.
- ➔ The subtitles cannot be changed for the titles recorded on this recorder.

The angles cannot be changed.

- ➔ Multi-angles are not recorded on the DVD VIDEO being played.
- ➔ You are trying to change the angles when “” does not appear on the TV screen (page 62).
- ➔ The DVD VIDEO prohibits changing angles.
- ➔ Try changing the angle using the DVD VIDEO's menu.
- ➔ The angles cannot be changed for the titles recorded on this recorder.

The MP3 audio tracks do not play.

- ➔ The MP3 audio tracks are not recorded in a format that the recorder can play (page 67).

The JPEG image files do not play.

- ➔ The JPEG image files are not recorded in a format that the recorder can play (page 67).
- ➔ Progressive JPEG images cannot be played.

TV Pause does not work.

- ➔ You are recording to the HDD or the HDD is full.

Recording/Timer recording/Editing**The programme position cannot be changed from the programme position you are recording.**

- ➔ Set the TV's input source to “TV.”

Recording does not start immediately after you press .

- ➔ Operate the recorder only after “LOAD,” “FORMAT,” or “INWRITE” disappears from the front panel display.

Nothing was recorded even though you set the timer setting correctly.

- ➔ There was a power failure during recording.
- ➔ The recorder's internal clock stopped due to a power failure that lasted for more than 1 hour. Reset the clock (page 94).
- ➔ The channel was disabled after the timer recording was set. See “Channel Setting” on page 90.
- ➔ Disconnect the mains lead from the mains, and connect it again.
- ➔ “PDC/VPS Scan Off” was selected in the TOOLS menu (page 51).
- ➔ The programme contains copy protection signals that restrict copying.
- ➔ Another timer setting overlapped the timer setting (page 56).
- ➔ There is no DVD inside the recorder.
- ➔ There is not enough disc space for the recording.

Recording does not stop immediately after you press .

- ➔ It will take a few seconds for the recorder to input disc data before recording can stop.

Recording does not stop after you press .

- ➔ Open the remote's cover and press  REC STOP.

Timer recording is not complete or did not start from the beginning.

- ➔ There was a power failure during recording. If the power recovers when there is a timer recording, the recorder resumes recording. Should the power failure continue for more than 1 hour, reset the clock (page 94).
- ➔ Another timer setting overlapped the timer setting (page 56).
- ➔ Disc space was not enough.
- ➔ The PDC/VPS function is working.

Contents previously recorded were erased.

- ➔ Data that has been recorded on a DVD with a PC will be erased from the disc when the disc is inserted.
- ➔ “Auto Title Erase” in the TOOLS menu (appears when you press TOOLS while the Timer List menu is turned on) is set to “On” (page 57).
- ➔ The title was updated and recorded over (page 50).

The PDC/VPS function does not operate.

- ➔ Check that the clock and date are set correctly.
- ➔ Check that the PDC/VPS time you set is the correct one (there might be a mistake in the TV programme guide). If the broadcast you wanted to record did not send the correct PDC/VPS information, the recorder will not start recording.
- ➔ If the reception is poor, the PDC/VPS signal might be altered and the recorder might not start recording.
- ➔ “PDC/VPS Scan Off” is selected (page 51).

Recording from equipment with a timer

Nothing was recorded even though you set the Synchro-Rec setting correctly.

- ➔ You forgot to turn off the connected equipment. Turn off the connected equipment and set the recorder to Synchro-Rec standby mode (page 57).
- ➔ The recorder was not set to the Synchro-Recording standby mode. Press SYNCHRO REC to have the recorder stand by for recording. Make sure the SYNCHRO REC indicator lights up on the front panel (page 57).
- ➔ The recorder is connected to the TV output jack of the connected equipment.

Synchro-Recording does not complete.

- ➔ The timer setting for the connected equipment overlapped the recorder’s timer setting (page 58).
- ➔ There was a power failure during the recording.

The recorder automatically starts recording when the satellite receiver is turned on.

- ➔ The Synchro-Rec function was activated. Turn off the satellite receiver and cancel the Synchro-Rec function (page 57).

Display

The clock has stopped.

- ➔ Set the clock again (page 94).
- ➔ The clock stopped due to a power failure that lasted for more than 1 hour. Reset the clock (page 94).

The TIMER REC indicator is flashing.

- ➔ The disc does not have enough space.
- ➔ Insert a recordable disc inside the recorder.

The recording mode indication is incorrect.

- ➔ When the recording or dubbing is less than three minutes, the recording mode indication may be displayed incorrectly. The actual recording itself is correctly made in the selected recording mode.
- ➔ After playing titles recorded in SLP and SEP mode, the recording mode indication may change depending on the recorded programme.

The clock does not appear in the front panel display.

- ➔ “Dimmer” in “Options” setup is set to “Power Save” (page 103).
- ➔ The “Power Save” in “Options” setup was set to “On,” and the recorder is in standby (page 103).

Remote control

The remote does not function.

- ➔ Batteries are weak.
- ➔ The remote is too far from the recorder.
- ➔ The remote’s manufacturer code returned to the default setting when you replaced the batteries. Reset the code (page 88).
- ➔ Turn on the recorder.
- ➔ The remote is not pointed at the remote sensor on the recorder.
- ➔ Set the TV/DVD switch to DVD (page 88).

Others

The recorder does not operate properly.

- ➔ Restart the recorder. Press down **I/⏻** on the recorder for more than ten seconds until “WELCOME” appears in the front panel display.
- ➔ When static electricity, etc., causes the recorder to operate abnormally, turn off the recorder and wait until the clock appears in the front panel display. Then, unplug the recorder and after leaving it off for a while, plug it in again.

Five numbers or letters are displayed in the front panel display.

- ➔ The self-diagnosis function was activated (see the table on page 112).

The disc tray does not open after you press **⏏ (open/close).**

- ➔ It may take a few seconds for the disc tray to open after you have recorded or edited a DVD. This is because the recorder is adding disc data to the disc.

The disc tray does not open and “TRAY LOCKED” appears in the front panel display.

- ➔ Contact your Sony dealer or local authorized Sony service facility.

“RECOVERY” appears in the front panel display.

- ➔ The recorder’s recovery function was activated when the recorder was turned on because the power was turned off or failed during recording. Leave the recorder on until “RECOVERY” disappears from the front panel display.

“HDD ERROR” appears in the front panel display.

- ➔ A hard disk error occurred. Press down **I/⏻** on the recorder for ten seconds until “WELCOME” appears in the front panel display. If this does not resolve the problem, format the recorder’s HDD by pressing down the HDD button on the recorder for more than ten seconds until “FORMAT” appears in the front panel display. Note that all the contents recorded on the HDD will be erased. If this does not fix the problem, contact your nearest Sony dealer.

The disc tray does not open and you cannot remove the disc after you press **⏏ (open/close).**

- ➔ Turn off the recorder. Once the clock appears in the front panel display, disconnect the mains lead. Connect it again while pressing down **⏏** on the recorder, and release the button when the disc tray opens. Then, keep **I/⏻** on the recorder pressed for about ten seconds until “WELCOME” appears in the front panel display.

“LOCKED” appears in the front panel display.

- ➔ The disc tray is locked. Cancel the Child Lock (page 61).

Mechanical sound is heard when the recorder is off.

- ➔ While the recorder is adjusting the clock for the Auto Clock Set function or scanning the channels for the PDC/VPS function, operational noises (such as the internal fan) may be heard, even when the power is off. This is not a malfunction.

The speaker does not work normally.

- ➔ Disconnect the mains lead of the subwoofer from the mains. Wait about two minutes until the POWER indicator on the subwoofer turns off, and then connect the mains lead.

Mechanical sound is heard from the subwoofer or the recorder when no disc is played.

- ➔ The recorder and the subwoofer have ventilation fans, which operate when the power is on. Mechanical sound may also be heard when the disc spins. These are operational sounds and are not malfunctions.

Mechanical sound is heard from the recorder or subwoofer.

- ➔ Internal fans rotate faster as temperature increases. This is not a malfunction.

“NOT IN USE” appears in the front panel display when FM/AM, \triangle +/-, etc., is pressed.

- ➔ Check the connection between the recorder and subwoofer.
- ➔ Turn on the subwoofer (the ON/STANDBY indicator on the subwoofer lights up in green).

“AMP PROTECT” appears in the front panel display, and the ON/STANDBY indicator on the subwoofer flashes in red.

- ➔ Amplifier section in the system is malfunctioning. Disconnect the subwoofer mains lead, and then reconnect the mains lead after about two minutes.

**Self-diagnosis Function
(When letters/numbers
appear in the display)**

When the self-diagnosis function is activated to prevent the recorder from malfunctioning, a five-character service number (e.g., C 13 00) with a combination of a letter and four numbers appears in the front panel display. In this case, check the following table.

First three characters of service number	Cause and/or corrective action
C 13	There is a problem in the HDD. ➔ Contact your nearest Sony dealer or local authorized service facility. The DVD is dirty. ➔ Clean the disc with a soft cloth.
C 31	The DVD/CD is not inserted correctly. ➔ Re-insert the disc correctly.
E XX (xx is a number)	To prevent a malfunction, the recorder has performed the self-diagnosis function. ➔ Contact your nearest Sony dealer or local authorized Sony service facility and give the five-character service number. Example: E 61 10

Notes About This Recorder

On operation

- If the recorder is brought directly from a cold to a warm location, or is placed in a very damp room, moisture may condense on the lenses inside the recorder. Should this occur, the recorder may not operate properly. In this case, remove the disc and leave the recorder turned on for about half an hour until the moisture evaporates.
- When you move the recorder, take out any discs. If you don't, the disc may be damaged.

On adjusting volume

Do not turn up the volume while listening to a section with very low level inputs or no audio signals. If you do, the speakers may be damaged when a peak level section is played.

On cleaning

Clean the cabinet, panel, and controls with a soft cloth slightly moistened with a mild detergent solution. Do not use any type of abrasive pad, scouring powder or solvent such as alcohol or benzene.

If you have any questions or problems concerning your system, please consult your nearest Sony dealer.

About repairing the hard disk drive

- It may be necessary to access data stored on the hard disk for testing purposes; there is no intention to copy or store the data, titles or any other information.
- If replacement or initialization (format) is required, the hard disk will be formatted at our discretion. In this case, please note that all of the contents recorded there will be erased (including any data found to violate copyright law).

On cleaning discs

Do not use a commercially available cleaning disc. It may cause a malfunction.

On mechanical sound

Sound may be heard from the system when internal high temperature increases. This indicates internal fan ventilation is functioning properly.

On your TV's colour

If the speakers should cause the TV screen to have colour irregularity, turn off the TV at once then turn it on after 15 to 30 minutes. If colour irregularity should persist, place the speakers farther away from the TV set.

Notes about the discs

- To keep the disc clean, handle the disc by its edge. Do not touch the surface. Dust, fingerprints, or scratches on the disc may cause it to malfunction.



- Do not expose the disc to direct sunlight or heat sources such as hot air ducts, or leave it in a car parked in direct sunlight as the temperature may rise considerably inside the car.
- After playing, store the disc in its case.
- Clean the disc with a cleaning cloth. Wipe the disc from the centre out.



- Do not use solvents such as benzene, thinner, commercially available cleaners, or anti-static sprays intended for vinyl LPs.
- Do not use the following discs.
 - A disc that has a non-standard shape (e.g., card, heart).
 - A disc with a label or sticker on it.
 - A disc that has cellophane tape or sticker adhesive on it.

Specifications

Design and specifications are subject to change without notice.

For supplied accessories, see page 12.

DVD recorder specifications

System

Laser: Semiconductor laser

Channel coverage:

PAL/SECAM (B/G, D/K, I, L)

VHF: E2 to E12, R1 to R12, F2 to F10, Italian A to H, Ireland A to J, South Africa 4 to 13/
UHF: E21 to E69, R21 to R69, B21 to B69,
F21 to F69/CATV: S01 to S05, S1 to S20,
France B to Q/HYPER: S21 to S41

The above channel coverage merely ensures the channel reception within these ranges. It does not guarantee the ability to receive signals in all circumstances.

Video reception: Frequency synthesizer system

Audio reception: Split carrier system

Aerial out: 75-ohm asymmetrical aerial socket

Timer: Clock: Quartz locked/Timer indication:
24-hour cycle (digital)/Power back-up
duration: 1 hour

Video recording format: MPEG Video

Audio recording format/applicable bit rate:

Dolby Digital 2 ch/256 kbps

Inputs and outputs

LINE OUT

(AUDIO): Phono jack/2 V_{rms}/10 kilohms

(VIDEO): Phono jack/1.0 V_{p-p}

(S VIDEO): 4-pin mini DIN/Y:1.0 V_{p-p},
C: 0.3 V_{p-p} (PAL)

LINE 2 IN/LINE 4 IN

(AUDIO): Phono jack/2 V_{rms}/more than
22 kilohms

(VIDEO): Phono jack/1.0 V_{p-p}

(S VIDEO): 4-pin mini DIN/Y:1.0 V_{p-p},
C: 0.3 V_{p-p} (PAL)

LINE 1 – TV: 21-pin

CVBS IN/OUT

S-Video/RGB OUT (upstream)

LINE 3/DECODER: 21-pin

CVBS IN/OUT

S-Video/RGB IN

S-Video OUT (downstream)

Decoder

COMPONENT VIDEO OUT

(Y, PB/CB, PR/CR):

Phono jack/Y: 1.0 V_{p-p}, PB/CB: 0.7 V_{p-p},

PR/CR: 0.7 V_{p-p}

General

Power requirements: 230 V AC, 50/60 Hz

Power consumption:

RH1000: 50 W

RH7000: 52 W

Dimensions (approx.): 430 × 75 × 343 mm

(width/height/depth) incl. projecting parts

Hard disk drive capacity:

RH1000: 160 GB

RH7000: 250 GB

Mass (approx.): 6.1 kg

Operating temperature: 5°C to 35°C

Operating humidity: 25% to 80%

Compatible colour systems

This recorder is designed to record using the PAL colour system and play back using the PAL or NTSC colour systems.

The signals of the SECAM colour system can be received or recorded but played back in the PAL colour system only. Recording of video sources based on other colour systems cannot be guaranteed.

Speaker system specifications

FM/AM tuner section

System: PLL quartz-locked digital synthesizer system

FM tuner: Tuning range: 87.5-108.0 MHz (50 kHz step)/Aerial type: FM wire aerial/Aerial terminal: 75 ohms, unbalanced/Intermediate frequency: 10.7 MHz

AM tuner: Tuning range: 531-1,602 kHz/Aerial type: AM loop aerial/Intermediate frequency: 450 kHz

AUDIO POWER

[RH7000]

Amplifier section

Stereo mode (rated):

120 W+120 W (2.7 ohms at 1 kHz, THD 10%)

Music power output when in surround mode (reference):

Front: 120 W+120 W (with SS-TS7000)/

Centre*: 120 W (with SS-CT7000)/

Surround*: 120 W+120 W (with SS-TS7001)/

Subwoofer*: 100 W × 2 (with SA-WSRH10)

* There may be no sound output depending on the source and the Sound Field setting.

Speakers

Front: Speaker system: Two-way bass reflex, magnetically shielded/Speaker unit: 50 mm dia. cone type × 2, 25 mm dia. balanced-dome-type tweeter/Rated impedance: 2.7 ohms/Dimensions (approx.): 68 × 380 × 53 mm (w/h/d)/220 × (398-530) × 220 mm (w/h/d) with stand/Mass (approx.): 1.3 kg, 2.7 kg with stand

Centre: Speaker system: Two-way bass reflex, magnetically shielded/Speaker unit: 50 mm dia. cone type × 2, 25 mm dia. balanced-dome-type tweeter/Rated impedance: 2.7 ohms/Dimensions (approx.): 380 × 68 × 53 mm (w/h/d)/Mass (approx.): 1.3 kg

Surround: Speaker system: Two-way bass reflex, magnetically shielded/Speaker unit: 50 mm dia. cone type × 2, 25 mm dia. balanced-dome-type tweeter/Rated impedance: 2.7 ohms/Dimensions (approx.): 68 × 240 × 53 mm (w/h/d)/Mass (approx.): 1.0 kg

Subwoofer: Speaker system: Bass reflex/Speaker unit: 180 mm cone type/Rated impedance: 4 ohms × 2/Dimensions (approx.): 240 × 557 × 290 mm (w/h/d) incl. projecting parts/Mass (approx.): 12.5 kg

Power requirements: 230 V AC, 50/60 Hz

Power consumption: On: 110 W/Standby: 0.3 W

[RH1000]

Amplifier section

Stereo mode (rated):

120 W+120 W (2.7 ohms at 1 kHz, THD 10%)

Music power output when in surround mode (reference):

Front: 120 W + 120 W (with SS-TS43)/

Centre*: 120 W (with SS-CT43)/

Surround*: 120 W + 120 W (with SS-TS43B)/

Subwoofer*: 100 W (with SA-WSRH1)

* There may be no sound output depending on the source and the Sound Field setting.

Speakers

Front: Speaker system: Bass reflex, magnetically shielded/Speaker unit: 70 × 100 mm cone type /Rated impedance: 2.7 ohms/Dimensions (approx.): 86 × 165 × 102 mm (w/h/d)/Mass (approx.): 0.7 kg

Centre: Speaker system: Bass reflex, magnetically shielded/Speaker unit: 55 × 110 cone type/Rated impedance: 2.7 ohms/Dimensions (approx.): 300 × 79 × 116 mm (w/h/d)/Mass (approx.): 1.0 kg

Surround: Speaker system: Bass reflex/Speaker unit: 70 × 100 mm cone type/Rated impedance: 2.7 ohms/Dimensions (approx.): 86 × 165 × 102 mm (w/h/d)/Mass (approx.): 0.6 kg

Subwoofer: Speaker system: Bass reflex/Speaker unit: 160 mm cone type/Rated impedance: 4 ohms/Dimensions (approx.): 240 × 557 × 290 mm (w/h/d) incl. projecting parts/Mass (approx.): 12.5 kg

Power requirements: 230 V AC, 50/60 Hz

Power consumption: On: 100 W/Standby: 0.3 W

Guide to Parts and Controls

For more information, see the pages in parentheses.

Remote

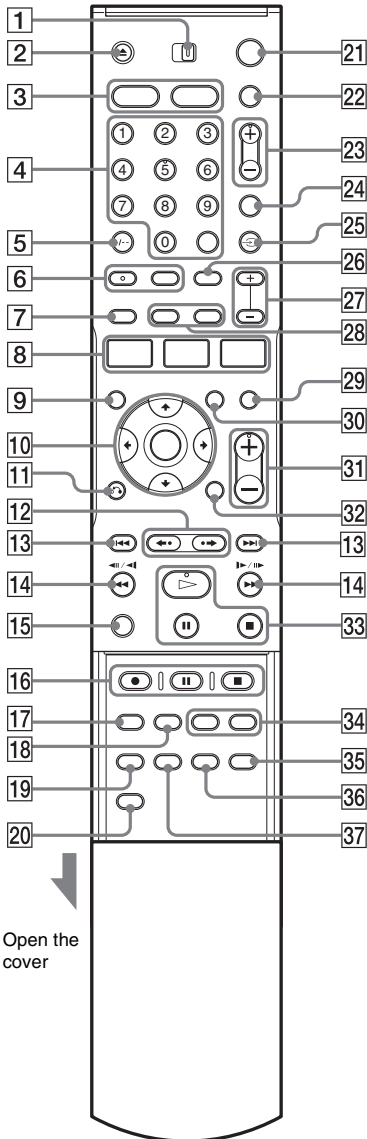

- 1 TV/DVD switch (88)
- 2 ▲ (open/close) button (36)
- 3 HDD button (38)
DVD button (36)
- 4 Number buttons (52, 66)
SET button (52)
The number 5 button has a tactile dot*.
- 5 CLEAR/-/- (ten digit) button (52)
- 6 ○○○ (audio) button (62)
⋮ (subtitle) button (62)
The ○○○ button has a tactile dot*.
- 7 TIMER button (50, 52)
- 8 SYSTEM MENU button (90)
TITLE LIST button (39, 60, 67, 72)
TIMER LIST button (55)
- 9 TOP MENU button (60)
- 10 ←/↑/↓/→/ENTER button (34)
- 11 ↻ RETURN button (55)
- 12 ◀• (instant replay)/▶• (instant advance) buttons (62, 67)
- 13 ◀◀/▶▶ (previous/next) buttons (62),
PRESET +/- buttons (87)
- 14 ◀◀◀||◀|▶|▶▶▶ (search) buttons (62)
- 15 VISUAL SEARCH button (66)
- 16 ● REC button (38)
|| REC PAUSE button (38)
■ REC STOP button (38)
- 17 REC MODE button (48)
- 18 SYNCHRO REC button (57)
- 19 PROGRESSIVE button (26)
- 20 ◻ (wide mode) button (88)
- 21 I/⏻ (on/standby) button (34)
- 22 FM/AM button (87)

23 PROG (programme) +/- buttons (38)

The + button has a tactile dot*.

24 INPUT SELECT button (59)

25  TV/DVD button (88)

26 DSGX button (86)

27 SOUND FIELD +/- buttons (84)

28 DISPLAY button (41)

TIME/TEXT button (41)

29 MUTING button (62)

30 MENU button (60)

31  (volume) +/- buttons (87)

The + button has a tactile dot*.

32 TOOLS button (36)

33  (play) button (60)

 (pause) button (62)

 (stop) button (60)

The  button has a tactile dot*.

34 CHAPTER MARK/CHAPTER MARK
ERASE buttons (75)

35  (angle) button (62)

36 FM/AM MEMORY button (87)

37 FM MODE button (87)

* Use the tactile dot as a reference when operating the system.

DVD recorder

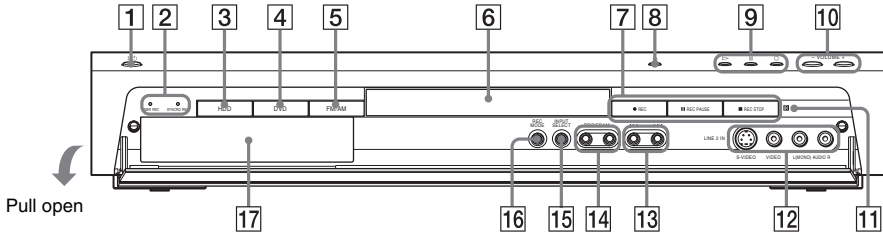

- | | |
|---|--|
| <p>1 I/O (on/standby) button (34)</p> <p>2 TIMER REC indicator (50)
SYNCHRO REC indicator (57)</p> <p>3 HDD button/indicator (38)</p> <p>4 DVD button/indicator (36)</p> <p>5 FM/AM button/indicator (87)</p> <p>6 Disc tray (36)</p> <p>7 ● REC button (38)
■ REC PAUSE button (38)
■ REC STOP button (38)</p> <p>8 ≡ (open/close) button (36)</p> | <p>9 ▷ (play) button (60)
■ (pause) button (62)
■ (stop) button (60)</p> <p>10 VOLUME +/- buttons (87)</p> <p>11 □ (remote sensor) (13)</p> <p>12 LINE 2 IN (S VIDEO/VIDEO/AUDIO L/R) jacks (30)</p> <p>13 ◀▶ (previous/next) buttons (62)</p> <p>14 PROGRAM +/- buttons (38)</p> <p>15 INPUT SELECT button (59)</p> <p>16 REC MODE button (48)</p> <p>17 Front panel display (42, 119)</p> |
|---|--|

Front panel display

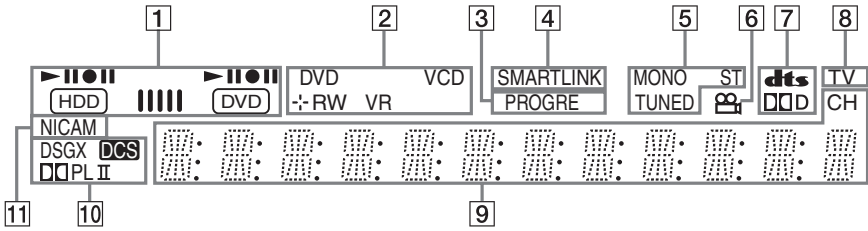

- 1** HDD/DVD indicators
Displays the selected media and the playing/recording/dubbing status or direction.
- 2** Disc type*/recording format
- 3** PROGRE (progressive) indicator (26)
- 4** SMARTLINK indicator (25)
- 5** Radio reception indicators (ST (stereo)/ MONO (monaural)/TUNED) (87)
- 6**  (angle) indicator (62)
- 7** Audio signal indicators (62)
- 8** TV indicator (38)
- 9** Displays the following (42):
 - Playing time/remaining time (42)
 - Current title/chapter/track/index number (42)
 - Recording time/recording mode
 - Clock
 - Programme position
 - TV Direct Rec indication (38): “TV” appears in the right most two digits.
 - Radio station/frequency (87)
 - Sound Field (84)
 - Function name (HDD/DVD/FM/AM) (38, 87)
- 10** DSGX indicator (86)
DCS indicator (85)
Dolby Pro Logic II indicator (84)
- 11** NICAM indicator (49)

* Displays DATA CDs as “CD.”

Hint

You can turn off the front panel display when the recorder is turned off by setting “Dimmer” to “Power Save” in “Options” setup (page 103).

Rear panel

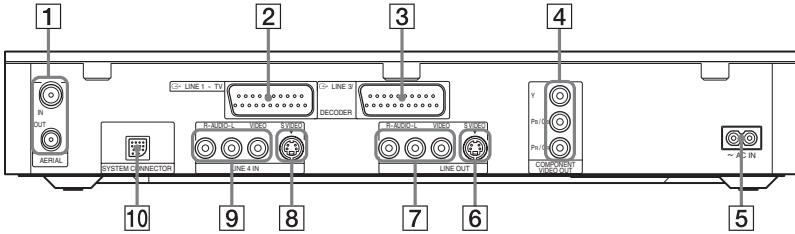

- 1** AERIAL IN/OUT jacks (23)
- 2** LINE 1 – TV jack (24)
- 3** LINE 3/DECODER jack (29)
- 4** COMPONENT VIDEO OUT (Y, Pb/Cb, Pr/Cr) jacks (24)
- 5** AC IN terminal (28)
- 6** LINE OUT (S VIDEO) jack (24)
- 7** LINE OUT (R-AUDIO-L/VIDEO) jacks (24, 27)
- 8** LINE 4 IN (S VIDEO) jack (30)
- 9** LINE 4 IN (R-AUDIO-L/VIDEO) jacks (30)
- 10** SYSTEM CONNECTOR jack (22)

Subwoofer (rear)

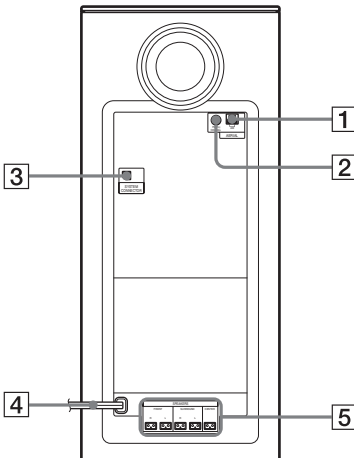

- 1** AERIAL (AM) terminal (21)
- 2** AERIAL (FM 75Ω COAXIAL) jack (21)
- 3** SYSTEM CONNECTOR jack (22)
- 4** Mains lead (28)
- 5** SPEAKER (FRONT R/FRONT L/SURROUND R/SURROUND L/CENTER) terminals (14)

Glossary

Album (page 67)

A unit in which to store JPEG image files or MP3 audio tracks on a DATA CD. (Album is an exclusive definition for this recorder.)

Chapter (page 66)

Sections of a picture or a music feature that are smaller than titles. A title is composed of several chapters. Depending on the disc, no chapters may be recorded.

Copy protection signals (page 49)

Copy restriction set by copyright owners, etc. These signals are included in some software or TV programmes and restrict recording on this recorder.

Digital Cinema Sound (DCS) (page 85)

This is the generic name of the surround sound produced by digital signal processing technology developed by Sony. Unlike previous surround sound fields mainly directed at the reproduction of music, Digital Cinema Sound is designed specifically for the enjoyment of movies.

Dolby Digital (page 3)

Digital audio compression technology developed by Dolby Laboratories. This technology conforms to multi-channel surround sound. The rear channel is stereo and there is a discrete subwoofer channel in this format. Dolby Digital provides the same discrete channels of high quality digital audio found in "Dolby Digital" theatre surround sound systems.

Good channel separation is realized because all of the channel data is recorded discretely, and little deterioration occurs because all channel data processing is digital.

Dolby Pro Logic II (page 84)

Dolby Pro Logic II creates five full-bandwidth output channels from two channel sources. This is done using an advanced, high-purity matrix surround decoder that extracts the spatial properties of the original recording without adding any new sounds or tonal colorations.

◆Movie mode

The Movie mode is for use with stereo television shows and all programmes encoded in Dolby Surround. The result is enhanced sound field directionality that approaches the quality of discrete 5.1-channel sound.

◆Music mode

The Music mode is for use with any stereo music recordings, and provides a wide and deep sound space.

Dolby Surround Pro Logic (page 84)

As one method of decoding Dolby Surround, Dolby Surround Pro Logic produces four channels from two-channel sound. Compared with the former Dolby Surround system, Dolby Surround Pro Logic reproduces left-to-right panning more naturally and localizes sounds more precisely. To take full advantage of Dolby Surround Pro Logic, you should have one pair of surround speakers and a centre speaker. The surround speakers output monaural sound.

DTS (page 63)

Digital audio compression technology by Digital Theater Systems, Inc. This technology conforms to multi-channel surround sound. The rear channel is stereo and there is a discrete subwoofer channel in this format. DTS provides the same discrete channels of high quality digital audio. Good channel separation is realized because all of the channel data is recorded discretely, and little deterioration occurs because all channel data processing is digital.

DVD+R (page 8)

A DVD+R (read "plus R") is a recordable disc that is the same size as a DVD VIDEO. Contents can be recorded only once to a DVD+R, and will have the same format as a DVD VIDEO.

DVD+RW (page 8)

A DVD+RW (read “plus RW”) is a recordable and rewritable disc. DVD+RWs use a recording format that is comparable to the DVD VIDEO format.

DVD-R (page 8)

A DVD-R is a recordable disc that is the same size as a DVD VIDEO. Contents can be recorded only once to a DVD-R, and will have the same format as a DVD VIDEO.

DVD-RW (page 8)

A DVD-RW is a recordable and rewritable disc that is the same size as a DVD VIDEO. The DVD-RW has two different modes: VR mode and Video mode. DVDs created in Video mode have the same format as a DVD VIDEO, while discs created in VR (Video Recording) mode allow the contents to be programmed or edited.

DVD VIDEO (page 10)

A disc that contains up to eight hours of moving pictures on a disc the same diameter as a CD. The data capacity of a single-layer and single-sided DVD is 4.7 GB (Giga Byte), which is 7 times that of a CD. The data capacity of a double-layer and single-sided DVD is 8.5 GB, a single-layer and double-sided DVD is 9.4 GB, and double-layer and double-sided DVD is 17 GB. The picture data uses the MPEG 2 format, which is a worldwide standard of digital compression technology. The picture data is compressed to about 1/40 (average) of its original size. The DVD also uses a variable rate coding technology that changes the data to be allocated according to the status of the picture. Audio information is recorded in a multi-channel format, such as Dolby Digital, allowing you to enjoy a more real audio presence.

Furthermore, various advanced functions such as the multi-angle, multilingual, and Parental Control functions are provided on the DVD.

Hard disk drive (page 2)

A hard disk drive is a whole mechanical system that consists of disks and drive. Disks are flat, circular, rigid plates coated with a thin magnetic media. Magnetic heads record data on the rapidly spinning disks, and this enables the speedy and efficient reading and writing of data.

File (page 66)

A JPEG image recorded on a DATA CD. (File is an exclusive definition for this recorder.) A single file consist of a single image.

Interlace format (page 26)

Interlace format shows every other line of an image as a single “field” and is the standard method for displaying images on television. The even number field shows the even numbered lines of an image, and the odd numbered field shows the odd numbered lines of an image.

MPEG Audio (page 62)

International standard coding system used to compress audio digital signals authorized by ISO/IEC. MPEG 2, used on DVDs, conforms to up to 7.1-channel surround.

Original (page 71)

Titles actually recorded on a HDD/DVD-RW (VR mode). Erasing original titles frees up disc space.

Playlist (page 71)

Playback information created from the actual recordings on a HDD/DVD-RW (VR mode). A Playlist leaves the original titles as they are, and contains only the information needed to control playback. A Playlist title takes up very little disc space.

Progressive format (page 26)

Compared to the Interlace format that alternately shows every other line of an image (field) to create one frame, the Progressive format shows the entire image at once as a single frame. This means that while the Interlace format can show 25-30 frames/50-60 fields in one second, the Progressive format can show 50/60 frames in one second. The overall picture quality increases and still images, text, and horizontal lines appear sharper.

Title (page 66)

The longest section of a picture or music feature on a DVD, movie, etc., in video software, or the entire album in audio software.

Track (page 66)

Sections of a music feature on a CD/VIDEO CD (the length of a song).

Language Code List

For details, see page 95.

The language spellings conform to the ISO 639: 1988 (E/F) standard.

Code Language	Code Language	Code Language	Code Language
1027 Afar	1183 Irish	1347 Maori	1507 Samoan
1028 Abkhazian	1186 Scots Gaelic	1349 Macedonian	1508 Shona
1032 Afrikaans	1194 Galician	1350 Malayalam	1509 Somali
1039 Amharic	1196 Guarani	1352 Mongolian	1511 Albanian
1044 Arabic	1203 Gujarati	1353 Moldavian	1512 Serbian
1045 Assamese	1209 Hausa	1356 Marathi	1513 Siswati
1051 Aymara	1217 Hindi	1357 Malay	1514 Sesotho
1052 Azerbaijani	1226 Croatian	1358 Maltese	1515 Sundanese
1053 Bashkir	1229 Hungarian	1363 Burmese	1516 Swedish
1057 Byelorussian	1233 Armenian	1365 Nauru	1517 Swahili
1059 Bulgarian	1235 Interlingua	1369 Nepali	1521 Tamil
1060 Bihari	1239 Interlingue	1376 Dutch	1525 Telugu
1061 Bislama	1245 Inupiak	1379 Norwegian	1527 Tajik
1066 Bengali;	1248 Indonesian	1393 Occitan	1528 Thai
Bangla	1253 Icelandic	1403 (Afan)Oromo	1529 Tigrinya
1067 Tibetan	1254 Italian	1408 Oriya	1531 Turkmen
1070 Breton	1257 Hebrew	1417 Punjabi	1532 Tagalog
1079 Catalan	1261 Japanese	1428 Polish	1534 Setswana
1093 Corsican	1269 Yiddish	1435 Pashto;	1535 Tonga
1097 Czech	1283 Javanese	Pushto	1538 Turkish
1103 Welsh	1287 Georgian	1436 Portuguese	1539 Tsonga
1105 Danish	1297 Kazakh	1463 Quechua	1540 Tatar
1109 German	1298 Greenlandic	1481 Rhaeto-	1543 Twi
1130 Bhutani	1299 Cambodian	Romance	1557 Ukrainian
1142 Greek	1300 Kannada	1482 Kirundi	1564 Urdu
1144 English	1301 Korean	1483 Romanian	1572 Uzbek
1145 Esperanto	1305 Kashmiri	1489 Russian	1581 Vietnamese
1149 Spanish	1307 Kurdish	1491 Kinyarwanda	1587 Volapük
1150 Estonian	1311 Kirghiz	1495 Sanskrit	1613 Wolof
1151 Basque	1313 Latin	1498 Sindhi	1632 Xhosa
1157 Persian	1326 Lingala	1501 Sangho	1665 Yoruba
1165 Finnish	1327 Laothian	1502 Serbo-	1684 Chinese
1166 Fiji	1332 Lithuanian	Croatian	1697 Zulu
1171 Faroese	1334 Latvian;	1503 Singhalese	
1174 French	Lettish	1505 Slovak	
1181 Frisian	1345 Malagasy	1506 Slovenian	1703 Not specified

Area Code

For details, see page 99.

Code Area	Code Area	Code Area	Code Area
2044 Argentina	2165 Finland	2362 Mexico	2149 Spain
2047 Australia	2174 France	2376 Netherlands	2499 Sweden
2046 Austria	2109 Germany	2390 New Zealand	2086 Switzerland
2057 Belgium	2248 India	2379 Norway	2528 Thailand
2070 Brazil	2238 Indonesia	2427 Pakistan	2184 United
2079 Canada	2254 Italy	2424 Philippines	Kingdom
2090 Chile	2276 Japan	2436 Portugal	
2092 China	2304 Korea	2489 Russia	
2115 Denmark	2363 Malaysia	2501 Singapore	

Index

Words in quotations appear in the on-screen displays.

Numerics

- 16:9 35, 95
- 4:3 Letter Box 35, 95
- 4:3 Pan Scan 35, 95

A

- A/V SYNC 64
- “A-B Erase” 73
- Adjusting
 - playback picture 63
 - recording picture 54
- Aerial 21, 23
- “AFT” 91
- Album 42, 67, 70
- Album number 42
- “Album Search” 66
- Angle 62
- Area code 123
- Audio 62, 97
- Audio cord 27
- “Audio DRC” 97
- “Audio” 95
- “Audio Setting” 64
- “Auto Adjust” 94
- “Auto Chapter” 98
- Auto Clock Set 94
- “Auto Display” 104
- “Auto Title Erase” 57

B

- Batteries 13
- “Bilingual” 58, 59
- Bilingual recording 49
- “BNR” 63
- “Brightness” 54, 63

C

- “C NR” 63
- Canal Plus 32
- “Capture All” 76
- “Capture” 76
- “CATV” 90

- CD 10
- “Change IN” 77
- “Change Order” 77
- “Change OUT” 77
- “Channel List” 93
- “Channel Setting” 90
- Chapter 42, 55, 66, 75, 121
- CHAPTER MARK 75
- CHAPTER MARK ERASE 75
- Chapter number 42
- “Chapter Search” 66
- Chasing Playback 64
- “Check Overlap” 56
- Checking/changing/cancelling timer settings (Timer List) 55
- Child Lock 61
- Cleaning discs 113
- Clock 34, 94
- “Colour” 54, 63
- “Colour System” 100
- Colour systems 114
- “Combine” 77
- “Component Out” 96
- COMPONENT VIDEO OUT 24
- Connecting
 - the audio cords 27
 - the FM/AM aerials 21
 - the speaker system 14
 - the TV aerial cable 23
- “Contrast” 54, 63
- Controlling TVs with the remote 88
- Copy control signals 49
- Copy protection 121
- Copy-Free 49
- Copy-Never 49
- Copy-Once 49
- CPRM 8
- “Create Playlist” 76
- Creating chapters 55

D

- DATA CD 10
- DCS 85
- “Decoder” 33
- “Delete Chapter” 73

- “Dimmer” 103
- “Disc Info” 36, 45, 75
- Disc Map 75
- Disc Settings 36, 45, 75, 103
- Disc space 37
- Disc types 8
- Display
 - front panel display 42, 119
- “Distance” 101
- “Divide” 74
- Dolby Digital 121
- DSGX 86
- DTS 63, 121
- “Dub Mode” 79
- Dubbing
 - “Dub Mode” 79
 - “Dub Selected Titles” 82
 - High-speed Dubbing 79
 - Rec Mode Conversion Dubbing 80
 - “Title Dub” 81
 - “Settings” 83
- “DVD Bilingual Rec.” 103
- “DVD Menu” 95
- “DVD Rec. Picture Size” 54
- DVD VIDEO 10, 122
- DVD+R 8, 121
- DVD+RW 8, 122
- DVD-R 8, 122
- DVD-RW 8, 122
- DVD-RW (Video mode) 72
- “DVE” 63

E

- Easy Setup 34, 104
- Editing 71, 76
- Enter characters 43
- “Erase All” 75
- “Erase” 56, 72, 77
- “Erase Titles” 74
- “Extend Rec” 51

F

“Factory Setup” 104
“Features” 98
File 67, 122
“File Search” 66
“Finalize” 46
Finalizing 46
“Format DVD-RW” 103
Formatting 36
Freeze Frame 62
Front panel 118
Front panel display 42, 119

G

GB 37

H

Handling discs 113
“HDD Bilingual Rec.” 103
Hookups and settings
overview 12
“Hue” 63

I

INPUT SELECT 59
Interlace 122

J

JPEG image files 67

L

Labelling 45
Language 95
“Level” 102
LINE 2 IN 30
LINE 3/DECODER 29
LINE 4 IN 30
“Line Audio Input” 58, 59
LINE OUT 24
“Line1 Output” 96
“Line3 Input” 97
“Line3 Output” 97
“Line4 Input” 97

M

Mains lead 28
Manual Clock Set 94
MENU 60

Menu

DVD’s Menu 60
Top menu 60
“MNR” 63
“Modify” 56
“Move” 77
MP3 audio tracks 67
MPEG 122
Muting 62

N

NICAM 49, 91
“Normal” 90
Number buttons 44, 52

O

One Touch Menu 61
One Touch Play 61
One Touch Timer 51
On-screen display
“OSD” language 34, 95
“Options” 103
Original 40, 71, 122

P

Page mode 40
Parental Control 61, 99
Parts and controls 116
“Pause Mode” 96
PAY-TV 32
“PAY-TV/CANAL +” 92
“PB Video Equalizer” 63
PBC 60
PDC 51
Picture quality 54, 63
Picture size 54
“Play Beginning” 61
Play mode 42
Playable discs 10
Playback 10, 42, 60, 62
fast forward 62
fast reverse 62
freeze frame 62
instant advance 62
instant replay 62
JPEG image files 67
MP3 audio tracks 67
resume play 61
Scan Audio 60

slow-motion play 62

Playing status bar 42
Playlist 40, 71, 76, 122
“Power Save” 103
“Present Time” 94
“Preview” 77
Progressive 26, 122
“Progressive Mode” 96
“Protect Disc” 45
“Protect” 72
Protection
disc 45
title 72

Q

Quick guide to disc types 8
Quick Timer 53

R

Radio 87
Rear panel 120
REC 38
Rec Mode Adjust 51
“Rec Mode” 54
“Rec NR” 54
REC PAUSE 38
“Rec Settings” 54
REC STOP 38
“Rec Video Equalizer” 54
Recordable discs 8
Recording 48, 57, 98
picture adjustment 54
recording format 8
recording mode 39, 48
recording time 39
“Update” 50
while watching another
programme 38
Recording time 48
RECOVERY 111
Region code 11
Remaining time 42
Remote 13
Resetting the recorder 104
Resume Play 61
“RGB” 35, 96
“Room Size” 35

S

S VIDEO 25
“S Video” 35, 96
Scan Audio 60
“Scart Setting” 96
Scene List 76
“Screen Saver” 100
“Search” 66
Searching
 fast reverse/fast forward
 62
 locating the beginning of
 the title/chapter/
 track 62
 Scan Audio 60
 search mode 66
 Visual Search 66
SET 44, 89
“Set Thumbnail” 72
“Settings” 90
Simultaneous Rec and Play 65
“Size” 101
Slow-motion play 62
SMARTLINK 25
Sort 40
Sound Field 84
“Speaker” 100
Speaker cords 14
Speaker position 16
“Station Name” 92
Subtitle 62, 95
Super VIDEO CD 10
Surround sound 84
Synchro Rec 57
SYSTEM CONNECTOR 22
System cord 22
“System” 90

T

Teletext 39, 93
“Test Tone” 102
Thumbnail picture 41
“Time Search” 66
TIME/TEXT 42
TIMER 50
Timer List 55
Timer recording
 check/change/cancel 55
 Rec Mode Adjust 51

Synchro Rec 57
 Video Plus+ 52
Title 42, 122
TITLE LIST 60
Title List 39, 60
 Sort 40
 Thumbnail 41
“Title Name” 72
Title number 42
“Title Search” 66
TOP MENU 60
Track 42, 66, 122
“Track Search” 66
Troubleshooting 105
Tuner System 34
TV aerial 23
“TV Direct Rec” 38, 98
“TV Guide Page” 93
TV Pause 64
TV system 90
“TV Type” 35, 95
TV/DVD 38
TV/DVD switch 88

U

“Unfinalize” 47
Unfinalizing 47
Usable discs 8

V

VIDEO CD 10
Video cord 24
“Video” 35, 95, 96
Video input 25
Video mode 8
Video Plus+ 52
“Video Settings” 63
Visual Search 66
VPS 51
VR mode 8, 71

Y

“Y NR” 63

Z

ZWEITON 49

