

SONY

SONY®

HANDYCAM

Digital Video Camera Recorder

HANDYCAM®

Operating Guide

**DCR-DVD610/DVD710/
DVD810**

US

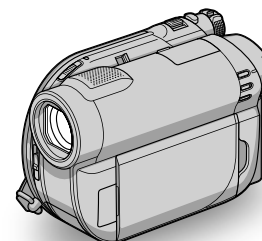

Enjoying with Your Camcorder 12

Getting Started 20

Recording/Playback 34

Editing 50

Utilizing Media 66

Customizing Your Camcorder 78

Performing with Your Computer 97

Troubleshooting 101

Additional Information 114

Quick Reference 129

Spanish Quick Guide/
Guía rápida en español 140

Additional information on this product and answers to frequently asked questions can be found at our Customer Support Website.

<http://www.sony.net/>



Printed on 70% or more recycled paper using VOC (Volatile Organic Compound)-free vegetable oil based ink.

Printed in China



3285366110



IMPORTANT SAFEGUARDS

WARNING

To reduce fire or shock hazard, do not expose the unit to rain or moisture.

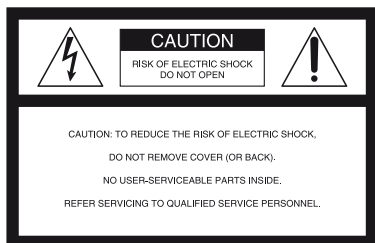

This symbol is intended to alert the user to the presence of uninsulated “dangerous voltage” within the product’s enclosure that may be of sufficient magnitude to constitute a risk of electric shock to persons.



This symbol is intended to alert the user to the presence of important operating and maintenance (servicing) instructions in the literature accompanying the appliance.

For your protection, please read these safety instructions completely before operating the appliance, and keep this manual for future reference.

Carefully observe all warnings, precautions and instructions on the appliance, or the one described in the operating instructions and adhere to them.

Use

Power Sources

This set should be operated only from the type of power source indicated on the marking label. If you are not sure of the type of electrical power supplied to your home, consult your dealer or local power company. For those sets designed to operate from battery power, or other sources, refer to the operating instructions.

Polarization

This set may be equipped with a polarized ac power cord plug (a plug having one blade wider than the other).

This plug will fit into the power outlet only one way. This is a safety feature. If you are unable to insert the plug fully into the outlet, try reversing the plug. If the plug should still fail to fit, contact your electrician to have a suitable outlet installed. Do not defeat the safety purpose of the polarized plug by forcing it in.

Overloading

Do not overload wall outlets, extension cords or convenience receptacles beyond their capacity, since this can result in fire or electric shock.

Object and Liquid Entry

Never push objects of any kind into the set through openings as they may touch dangerous voltage points or short out parts that could result in a fire or electric shock. Never spill liquid of any kind on the set.

Attachments

Do not use attachments not recommended by the manufacturer, as they may cause hazards.

Cleaning

Unplug the set from the wall outlet before cleaning or polishing it. Do not use liquid cleaners or aerosol cleaners. Use a cloth lightly dampened with water for cleaning the exterior of the set.

Installation

Water and Moisture

Do not use power-line operated sets near water – for example, near a bathtub, washbowl, kitchen sink, or laundry tub, in a wet basement, or near a swimming pool, etc.

Power-Cord Protection

Route the power cord so that it is not likely to be walked on or pinched by items placed upon or against them, paying particular attention to the plugs, receptacles, and the point where the cord exits from the appliance.

Accessories

Do not place the set on an unstable cart, stand, tripod, bracket, or table. The set may fall, causing serious injury to a child or an adult, and serious damage to the set. Use only a cart, stand, tripod, bracket, or table recommended by the manufacturer.

Ventilation

The slots and openings in the cabinet are provided for necessary ventilation. To ensure reliable operation of the set, and to protect it from overheating, these slots and openings must never be blocked or covered.

- Never cover the slots and openings with a cloth or other materials.
- Never block the slots and openings by placing the set on a bed, sofa, rug, or other similar surface.
- Never place the set in a confined space, such as a bookcase, or built-in cabinet, unless proper ventilation is provided.
- Do not place the set near or over a radiator or heat register, or where it is exposed to direct sunlight.

Lightning

For added protection for this set during a lightning storm, or when it is left unattended and unused for long periods of time, unplug it from the wall

outlet and disconnect the antenna or cable system. This will prevent damage to the set due to lightning and power-line surges.

Service

Damage Requiring Service

Unplug the set from the wall outlet and refer servicing to qualified service personnel under the following conditions:

- When the power cord or plug is damaged or frayed.
- If liquid has been spilled or objects have fallen into the set.
- If the set has been exposed to rain or water.
- If the set has been subject to excessive shock by being dropped, or the cabinet has been damaged.
- If the set does not operate normally when following the operating instructions. Adjust only those controls that are specified in the operating instructions. Improper adjustment of other controls may result in damage and will often require extensive work by a qualified technician to restore the set to normal operation.
- When the set exhibits a distinct change in performance – this indicates a need for service.

Servicing

Do not attempt to service the set yourself as opening or removing covers may expose you to dangerous voltage or other hazards.

Refer all servicing to qualified service personnel.

Replacement parts

When replacement parts are required, be sure the service technician has used replacement parts specified by the manufacturer that have the same characteristics as the original parts.

Unauthorized substitutions may result in fire, electric shock, or other hazards.

Safety Check

Upon completion of any service or repairs to the set, ask the service technician to perform routine safety checks (as specified by the manufacturer) to determine that the set is in safe operating condition.

Read this before operating your camcorder

Before operating the unit, please read this manual thoroughly, and retain it for future reference.

WARNING

Do not expose the batteries to excessive heat such as sunshine, fire or the like.

CAUTION

The use of optical instruments with this product will increase eye hazard. Use of controls or adjustments or performance of procedures other than those specified herein may result in hazardous radiation exposure.

Replace the battery with the specified type only. Otherwise, fire or injury may result.

Owner's Record

The model and serial numbers are located on the bottom. Record the serial number in the space provided below. Refer to these numbers whenever you call upon your Sony dealer regarding this product.

Model No. DCR- _____

Serial No. _____

Model No. AC- _____

Serial No. _____

For customers in the U.S.A. and CANADA

RECYCLING LITHIUM-ION BATTERIES

Lithium-Ion batteries are recyclable. You can help preserve our environment by returning your used rechargeable batteries to the collection and recycling location nearest you.

For more information regarding recycling of rechargeable batteries, call toll free 1-800-822-8837, or visit <http://www.rbr.org/>



Caution: Do not handle damaged or leaking Lithium-Ion batteries.

For customers in the U.S.A.

If you have any questions about this product, you may call:

Sony Customer Information Center
1-800-222-SONY (7669).

The number below is for the FCC related matters only.

Regulatory Information

Declaration of Conformity

Trade Name: SONY

Model No.: DCR-DVD610

Responsible Party: Sony Electronics Inc.

Address: 16530 Via Esprillo, San Diego, CA 92127 U.S.A.

Telephone No.: 858-942-2230

This device complies with Part 15 of the FCC Rules. Operation is subject to the following two conditions: (1) This device may not cause harmful interference, and (2) this device must accept any interference received, including interference that may cause undesired operation.

Declaration of Conformity

Trade Name: SONY

Model No.: DCR-DVD710

Responsible Party: Sony Electronics Inc.

Address: 16530 Via Esprillo, San Diego, CA 92127 U.S.A.

Telephone No.: 858-942-2230

This device complies with Part 15 of the FCC Rules. Operation is subject to the following two conditions: (1) This device may not cause harmful interference, and (2) this device must accept any interference received, including interference that may cause undesired operation.

Declaration of Conformity

Trade Name: SONY

Model No.: DCR-DVD810

Responsible Party: Sony Electronics Inc.

Address: 16530 Via Esprillo, San Diego, CA 92127 U.S.A.

Telephone No.: 858-942-2230

This device complies with Part 15 of the FCC Rules. Operation is subject to the following two conditions: (1) This device may not cause harmful interference, and (2) this device must accept any interference received, including interference that may cause undesired operation.

CAUTION

You are cautioned that any changes or modifications not expressly approved in this manual could void your authority to operate this equipment.

Note

This equipment has been tested and found to comply with the limits for a Class B digital device, pursuant to Part 15 of the FCC Rules. These limits are designed to provide reasonable protection against harmful interference in a residential installation. This equipment generates, uses, and can radiate radio frequency energy and, if not installed and used in accordance with the instructions, may cause harmful interference to radio communications.

However, there is no guarantee that interference will not occur in a particular installation. If this equipment does cause harmful interference to radio or television reception, which can be determined by turning the equipment off and on, the user is encouraged to try to correct the interference by one or more of the following measures:

- Reorient or relocate the receiving antenna.
- Increase the separation between the equipment and receiver.
- Connect the equipment into an outlet on a circuit different from that to which the receiver is connected.
- Consult the dealer or an experienced radio/TV technician for help.

The supplied interface cable must be used with the equipment in order to comply with the limits for a

digital device pursuant to Subpart B of Part 15 of FCC Rules.

Battery pack

This device complies with Part 15 of the FCC Rules. Operation is subject to the following two conditions:

- (1) This device may not cause harmful interference, and
- (2) this device must accept any interference received, including interference that may cause undesired operation.

This Class B digital apparatus complies with Canadian ICES-003.

For the State of California, USA only

Perchlorate Material - special handling may apply, See

www.dtsc.ca.gov/hazardouswaste/perchlorate

Perchlorate Material: Lithium battery contains perchlorate.

Notes on use

Your camcorder is supplied with two kinds of operations guides.

- "Operating Guide" (This manual)
- "PMB Guide" for using your camcorder with a computer connected (stored on the supplied CD-ROM) (p. 97)

Types of the disc you can use in your camcorder

You can use the following discs only.

- 8cm DVD-RW
- 8cm DVD+RW
- 8cm DVD-R
- 8cm DVD+R DL

Use the discs with marks listed below. See page 13 for details.



For reliability and durability of recording/playback, we recommend that you use Sony

Read this before operating your camcorder (Continued)

discs or discs with a  (for VIDEO CAMERA) mark for your camcorder.

* Depending on the place you purchase, the disc has  mark.

Note

- Using a disc other than the above may cause the unsatisfactory recording/playback or you may not be able to remove the disc from your camcorder.

Types of “Memory Stick” you can use in your camcorder

- For recording movies, it is recommended that you use a “Memory Stick PRO Duo” of 512 MB or larger marked with:
 - MEMORY STICK PRO DUO (“Memory Stick PRO Duo”)*
 - MEMORY STICK PRO-HG DUO (“Memory Stick PRO-HG Duo”)
- * You can use a “Memory Stick PRO Duo” marked either with “Mark2” or without.
- See page 33 for the recordable time of a “Memory Stick PRO Duo.”

“Memory Stick PRO Duo”/“Memory Stick PRO-HG Duo”

(This size can be used with your camcorder.)



“Memory Stick”

(You cannot use it in your camcorder.)





- “Memory Stick PRO Duo” and “Memory Stick PRO-HG Duo” are both referred to as “Memory Stick PRO Duo” in this manual.
- You cannot use any type of memory card other than those mentioned above.
- “Memory Stick PRO Duo” can be used only with “Memory Stick PRO” compatible equipment.

- Do not attach a label or the like on a “Memory Stick PRO Duo” or a Memory Stick Duo adaptor.
- When using a “Memory Stick PRO Duo” with “Memory Stick” compatible equipment, be sure to insert the “Memory Stick PRO Duo” into the Memory Stick Duo adaptor.

Using the camcorder

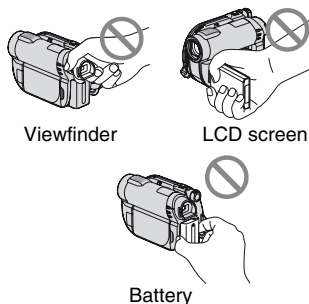
- Do not hold the camcorder by the following parts.



- The camcorder is not dustproofed, dripproofed or waterproofed. See “About handling of your camcorder” (p. 121).
- To prevent media from being broken or recorded images from being lost, do not do the following when either of the  (Movie)  (Still) lamps (p. 25) or the ACCESS/access lamps (p. 30, 32) are on:
 - to remove the battery pack or AC Adaptor from the camcorder
 - to apply mechanical shock or vibration to the camcorder
 - to remove the “Memory Stick PRO Duo” from the camcorder
- When connecting your camcorder to another device with a cable, be sure to insert the connector plug in the correct way. Pushing the plug forcibly into the terminal will damage the terminal and may result in a malfunction of your camcorder.

About menu items, LCD panel, viewfinder, and lens

- A menu item that is grayed out is not available under the current recording or playback conditions.
- The LCD screen and the viewfinder are manufactured using extremely high-precision technology, so over 99.99% of the pixels are effective. However, there may be some tiny black points and/or bright points (white, red, blue, or green in color) that appear constantly on the LCD screen and the viewfinder. These points are normal results of the manufacturing process and do not affect the recording in any way.

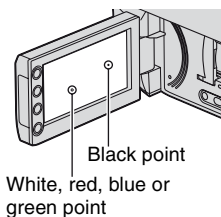

- Exposing the LCD screen, the viewfinder, or the lens to direct sunlight for long periods of time may cause malfunctions.
- Do not aim at the sun. Doing so might cause your camcorder to malfunction. Take images of the sun only in low light conditions, such as at dusk.

On recording

- Before starting to record, test the recording function to make sure the image and sound are recorded without any problems.
 - DCR-DVD610/DVD710
Use a DVD-RW/DVD+RW for trial recording.
 - DCR-DVD810
Make trial recording on the internal memory.
- Compensation for the contents of recordings cannot be provided, even if recording or playback is not possible due

to a malfunction of the camcorder, recording media, etc.

- TV color systems differ depending on the countries/regions. To view your recordings on a TV, you need an NTSC system-based TV.
- Television programs, films, video tapes, and other materials may be copyrighted. Unauthorized recording of such materials may be contrary to the copyright laws.
- If you repeat recording/deleting images for a long time, fragmentation of data occurs on the internal memory (DCR-DVD810) or a “Memory Stick PRO Duo.” Images cannot be saved or recorded. In such a case, save your images on another type of media first (p. 55, 62), and then format the media (p. 72).

About language setting

The on-screen displays in each local language are used for illustrating the operating procedures. Change the screen language before using your camcorder if necessary (p. 26).

About disposal/transfer (DCR-DVD810)

Even if you format the internal memory on your camcorder (p. 72), data may not be completely deleted from the internal memory. When you give or sell your camcorder to somebody, it is recommended that you perform [ EMPTY] (p. 77) to prevent the recovery of your data. In addition to the above, when you dispose of the camcorder, it is recommended that you destroy the actual body of the camcorder.

About the Carl Zeiss lens

Your camcorder is equipped with a Carl Zeiss lens, which was developed jointly by Carl Zeiss, in Germany, and Sony Corporation, and produces superior images. It adopts the MTF measurement system for video cameras and offers a quality typical of a Carl Zeiss lens.

Read this before operating your camcorder (Continued)

MTF = Modulation Transfer Function. The number value indicates the amount of light from a subject coming into the lens.

About this manual

- The LCD screens and the viewfinder images and indicators shown in this manual were taken with a digital still camera, and may look different from what you actually see.
- Discs in this manual refers to 8cm DVD discs.
- In this manual, the internal memory (DCR-DVD810), a disc and a “Memory Stick PRO Duo” are called the media.
- Unless otherwise specifically indicated, illustrations in this manual are based on DCR-DVD810.
- Design and specifications of media and other accessories are subject to change without notice.

About the marks used in this manual

- The operations available depend on the media used. The following marks are used to indicate the type of media you can use for a particular operation.

Internal Memory



Disc





“Memory Stick PRO Duo”



Table of Contents

Read this before operating your camcorder	4
Table of Contents	9
Subject examples and solutions ...	11

Enjoying with Your Camcorder

Enjoy using various “Media” according to your needs	12
Media for your camcorder	13
Using your camcorder	15
“  HOME” and “  OPTION” - Taking advantage of two types of menus	17

Getting Started

Step 1: Checking supplied items ..	20
Step 2: Charging the battery pack	21
Step 3: Turning the power on, and setting the date and time	25
Changing the language setting ..	26
Step 4: Making adjustments before recording	26
Step 5: Selecting media	28
Step 6: Inserting a disc or a “Memory Stick PRO Duo”	30

Recording/Playback

Recording and playing back with ease (Easy Handycam operation)	34
Recording	38
Zooming	40
Recording sound with more presence (5.1ch surround recording) (DCR-DVD710/DVD810)	40
Starting to record quickly (QUICK ON)	41

Recording in dark places (NightShot plus)	41
Adjusting the exposure for backlit subjects	41
Recording in mirror mode	41

Playback	43
Searching for scenes with pinpoint accuracy (Film Roll Index)	45
Searching for desired scenes by a face (Face Index)	45
Searching for desired images by date (Date Index)	46
Using PB zoom	46
Playing back a series of still images (Slide show)	47
Playing the images on a TV	48

Editing

 (OTHERS) category	50
Deleting images	51
Capturing a still image from a movie	53
Dubbing/copying images to media within your camcorder	55
Dividing movies	58
Creating the Playlist	59
Dubbing movies to VCR or DVD/HDD recorders	62
Printing still images (PictBridge compliant printer)	64

Utilizing Media







 (MANAGE MEDIA) category ..	66
Making the disc compatible with playback on other devices (Finalizing)	67
Playing a disc on other devices	70
Checking media information	71
Formatting media	72

Table of Contents (Continued)

Recording additional movies after finalizing	74
Finding the right disc (DISC SELECT GUIDE)	75
Repairing the image database file	76
Preventing data on the internal memory from being recovered (DCR-DVD810)	77

Customizing Your Camcorder

What you can do with the  (SETTINGS) category of the  HOME MENU	78
Using the HOME MENU	78
List of the  (SETTINGS) category items	79
MOVIE SETTINGS	80
(Items for recording movies)	
PHOTO SETTINGS	82
(Items for recording still images)	
VIEW IMAGES SET	84
(Items to customize the display)	
SOUND/DISP SET	86
(Items to adjust sound and the screen)	
OUTPUT SETTINGS	87
(Items for when connecting other devices)	
CLOCK/ LANG	88
(Items to set clock and language)	
GENERAL SET	88
(Other setup items)	
Activating functions using the  OPTION MENU	90
Using the OPTION MENU	90
Recording items on the OPTION MENU	91
Viewing items on the OPTION MENU	91
Functions set in the  OPTION MENU	92

Performing with Your Computer

What you can do with Windows computer	97
---------------------------------------------	----

Troubleshooting

Troubleshooting	101
Warning indicators and messages	110

Additional Information

Using your camcorder abroad	114
File/folder structure on the internal memory (DCR-DVD810) and a "Memory Stick PRO Duo"	116
Maintenance and precautions	117
About the disc	117
About the "Memory Stick"	118
About the "InfoLITHIUM" battery pack	119
About handling of your camcorder	121
Specifications	125

Quick Reference

Identifying parts and controls	129
Indicators displayed during recording/playback	133
Glossary	135
Index	136

Subject examples and solutions

Shooting

Flowers in close-up



- ▶ PORTRAIT 94
- ▶ FOCUS 92
- ▶ TELE MACRO 92

A child on the stage under a spot light



- ▶ SPOTLIGHT 94

Focusing on the dog on the left side of the screen

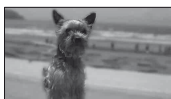

- ▶ FOCUS 92
- ▶ SPOT FOCUS 92

Fireworks with all its splendor



- ▶ FIREWORKS 93
- ▶ FOCUS 92

Getting a good shot of a ski slope or beach



- ▶ BACK LIGHT 41
- ▶ BEACH 94
- ▶ SNOW 94

A sleeping child under dim light



- ▶ NightShot plus 41
- ▶ COLOR SLOW SHTR 95

Checking your golf swing



- ▶ SPORTS 94

Enjoy using various “Media” according to your needs

Selecting media

You can select desired media for recording/playback/editing from the internal memory (DCR-DVD810), a disc or a “Memory Stick PRO Duo” (p. 28). To set the media for movies or still images, you can select either [MOVIE MEDIA SET] or [PHOTO MEDIA SET] (DCR-DVD810) according to your needs.

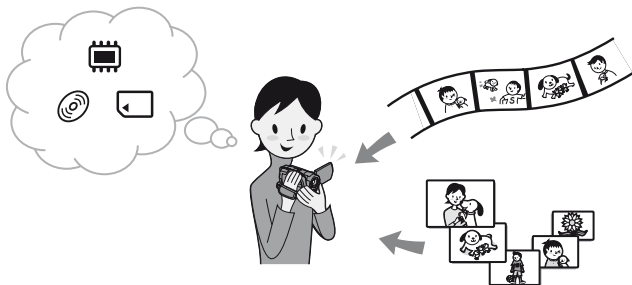

Dubbing from one type of media to another

Using the [MOVIE DUB] function on the camcorder, you can dub movies recorded on the internal memory (DCR-DVD810) or a “Memory Stick PRO Duo” to a disc without connecting another device (p. 55).

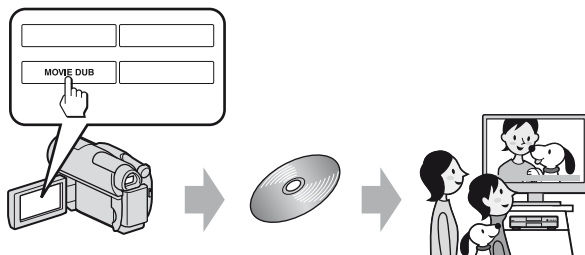

Notes

- You may not be able to dub movie contents depending on the type of your camcorder. For details on the compatibility of types, see page 55.



Media for your camcorder

With your camcorder, you can record images on either the internal memory (DCR-DVD810), an 8cm DVD-RW, DVD+RW, DVD-R or DVD+R DL disc, or a “Memory Stick PRO Duo.” See page 6 for the types of “Memory Stick” you can use in your camcorder.

Recording format for DVD-RW

When you use a DVD-RW, you can choose the recording format from VIDEO mode or VR mode.





In this manual, VIDEO mode is indicated as  and VR mode as .

	<p>A recording format that is compatible with most DVD devices, especially after finalizing. In VIDEO mode, only the most recent movie can be deleted.</p>
	<p>A recording format that enables editing with your camcorder (deleting and rearranging the order of images). A finalized disc can be played back in DVD devices that support VR mode. Refer to the instruction manual of your DVD device to see whether it supports the VR mode of DVD-RW.</p>

VIDEO mode and VR mode  Glossary (p. 135)

Disc features

Figures in parentheses () indicate reference pages.

Disc types and symbols	DVD-RW	DVD+RW	DVD-R	DVD+R DL
Symbols used in this manual				
Both 16:9 (wide) and 4:3 movie can be recorded on the same disc (30)	●	●	-	●
Deleting the most recent movie (52)	●	●	-	-
Deleting or editing movie on your camcorder (51)	-	●	-	-
Using a disc repeatedly by formatting, even if the disc becomes full* (72)	●	●	-	-
Finalizing required to play on other devices (67)	●	●	-**	●
Making longer recordings on a side of a disc	-	-	-	●

* Formatting deletes all images and returns the recording media to its original empty state (p. 72). Even when using a new disc, format it with your camcorder (p. 30).





** Finalizing is required to play the disc in a DVD drive on a computer. A DVD+RW that is not finalized may cause the computer to malfunction.

Recording time of movies

Figures in the table are the approximate recording time in minutes using the internal memory (DCR-DVD810) and on one side of a disc.

The recordable time on the acceptable media varies depending on media type and the [REC MODE] (p. 80) setting.

Figures in () are the minimum recording time.

Media type	 *	  	
9M (HQ) (high quality)	115 (100)	20 (18)	35 (32)
6M (SP) (standard quality)	170 (100)	30 (18)	55 (32)
3M (LP) (long play)	325 (215)	60 (44)	110 (80)

* DCR-DVD810

Tips

- Figures such as 9M and 6M in the table show the average bit rate. M stands for Mbps.
- You can check the recordable time with [MEDIA INFO] (p. 71).
- When you use a double-sided disc, you can record images on both sides (p. 117).
- See page 33 for the recordable time on a “Memory Stick PRO Duo.”

Your camcorder uses the VBR (Variable Bit Rate) format to automatically adjust image quality to suit the recording scene. This technology causes fluctuations in the recording time of media. Movies containing quickly moving and complex images are recorded at a higher bit rate, and this reduces the overall recording time.

Using your camcorder

① Selecting media (p. 28)

You can select media separately for movies and still images.

In the case of recording on a disc, select the disc that best suits your needs.



Do you want to delete or edit images on your camcorder?

Yes

No

Do you want to delete images and reuse the disc?

Yes

No

For long recording



* Select the recording format and format the disc on your camcorder (p. 30).

💡 Tips

- You can select the disc from [DISC SELECT GUIDE] (p. 75).

② Recording images (p. 38)

③ Editing/Saving images

The available functions depend on the selected media.

- **Dubbing/copying images to another type of media within your camcorder (p. 55)**
- **Dubbing movies to other devices (p. 62)**
- **Editing on a computer (p. 97)**

Using the supplied application software "Picture Motion Browser," you can import images to a computer, and save them on a disc.

④ Viewing on other devices

■ Viewing images on a TV (p. 48)

You can view the images recorded and edited on your camcorder on the connected TV.

■ Playing the disc on other devices (p. 70)

To play a disc recorded on your camcorder on other devices, you need to finalize the disc first.

🔊 Notes

- The less the recording volume of the disc is, the more it takes time to finalize the disc.

The features of a finalized disc depend on disc type.

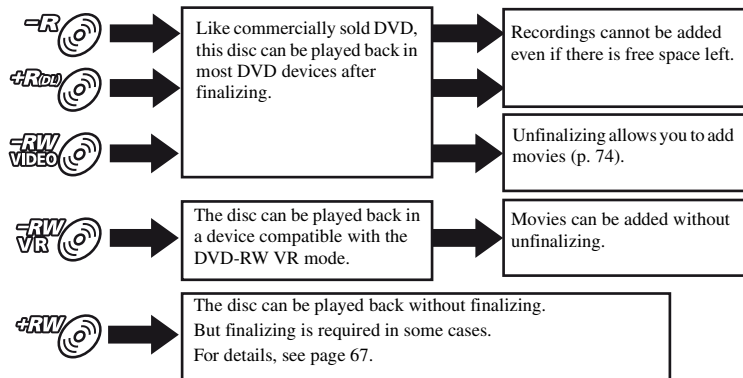

Playback compatibility

Playback compatibility with all DVD devices is not guaranteed. Refer to the instruction manual supplied with your DVD device or consult your dealer.

“HOME” and “OPTION”

- Taking advantage of two types of menus

“HOME MENU” - the starting point for operations with your camcorder



► Categories and items of the HOME MENU

(CAMERA) category

Items	Page
MOVIE* ¹	39
PHOTO* ¹	39

(VIEW IMAGES) category

Items	Page
VISUAL INDEX* ¹	43
INDEX* ¹	45
INDEX* ¹	45
PLAYLIST	59

(OTHERS) category

Items	Page
DELETE* ²	51
PHOTO CAPTURE* ³	53
MOVIE DUB* ³	55
PHOTO COPY* ³	56
EDIT	58
PLAYLIST EDIT	59
PRINT	64
USB CONNECT	97

(MANAGE MEDIA) category

Items	Page
MOVIE MEDIA SET* ¹	28
PHOTO MEDIA SET* ^{1*3}	28
FINALIZE* ¹	67
MEDIA INFO	71
MEDIA FORMAT* ¹	72
UNFINALIZE	74
DISC SELECT GUIDE	75
REPAIR IMG.DB F.	76

(SETTINGS) category*¹

To customize your camcorder (p. 78).

*¹ You can also set these items during Easy Handycam operation (p. 34). For items available in the (SETTINGS) category, see page 79.

*² The item is available during Easy Handycam operation (p. 34) when you select [INT. MEMORY] (DCR-DVD810) or [MEMORY STICK] on [MOVIE MEDIA SET] (p. 28).

*³ You may not be able to use this item depending on your camcorder model.

“HOME” and “OPTION” - Taking advantage of two types of menus (Continued)

Using the HOME MENU

- 1 While pressing the green button, turn the POWER switch in the direction of the arrow to turn on your camcorder.

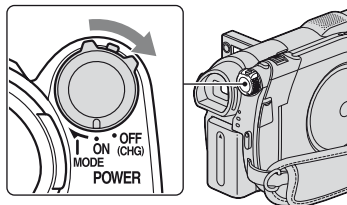

- 2 Press **HOME** (A) (or B).

HOME (A)

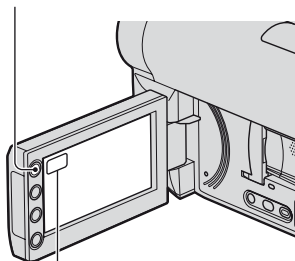

HOME (B)

- 3 Touch the desired category.

Example: (OTHERS) category



- 4 Touch the desired item.

Example: [EDIT]

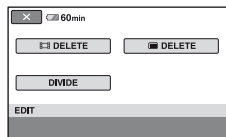

- 5 Follow the guide on the screen for further operation.

To hide the HOME MENU screen

Touch .

When you want to know something about the function of each item on the HOME MENU - HELP

- 1 Press **HOME**.

The HOME MENU appears.



- 2 Touch (HELP).

The bottom of (HELP) turns orange.



3 Touch the item you want to know the content.



When you touch an item, its explanation appears on the screen.

To apply the option, touch [YES], otherwise, touch [NO].

To deactivate the HELP

Touch [?] (HELP) again in step 2.

Using the OPTION MENU

Just a touch on the screen during shooting or playback displays the functions available at that moment. You will find it easy to make various settings. See page 90 for further details.

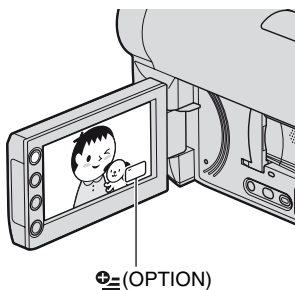

Step 1: Checking supplied items

Make sure that you have the following items supplied with your camcorder. The number in the parentheses indicates the number of that item supplied.

AC Adaptor (1) (p. 21)

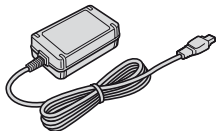

Power cord (mains lead) (1) (p. 21)



A/V connecting cable (1) (p. 48, 62)



USB cable (1) (p. 64)

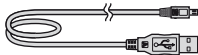

Wireless Remote Commander (DCR-DVD710/DVD810) (1) (p. 132)



A button-type lithium battery is already installed.

Rechargeable battery pack NP-FH40 (1) (p. 21)

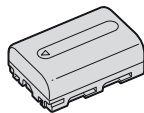

CD-ROM "Handycam Application Software" (1) (p. 97)

- Picture Motion Browser (Software)
- PMB Guide

Operating Guide (This manual) (1)

Step 2: Charging the battery pack

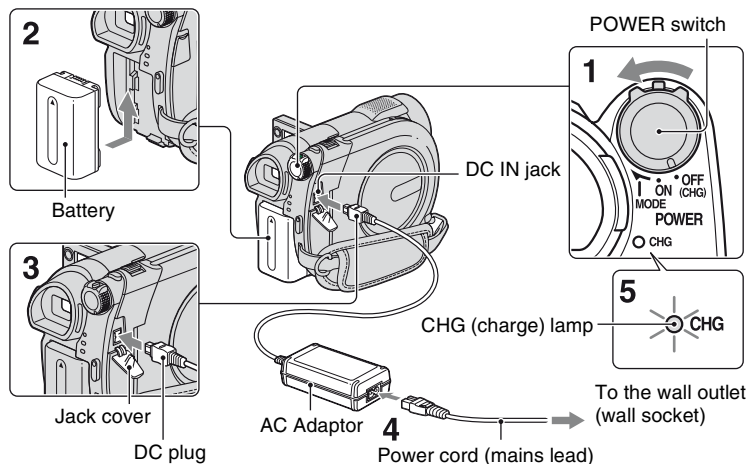

You can charge the “InfoLITHIUM” battery pack (H series) (p. 119) after attaching it to your camcorder.

⚙ Notes

- Your camcorder operates only with “InfoLITHIUM” battery pack (H series).

- 1** Turn the POWER switch in the direction of the arrow to OFF (CHG) (the default setting).
- 2** Attach the battery pack by sliding it in the direction of the arrow until it clicks.
- 3** Connect the AC Adaptor to the DC IN jack of your camcorder.
Open the jack cover, and connect the DC plug of the AC Adaptor.

Match the ▲ mark on the DC plug with the ▲ mark on your camcorder.

- 4** Connect the power cord (mains lead) to the AC Adaptor and the wall outlet (wall socket).

The CHG (charge) lamp lights up and charging starts.

- 5** The CHG (charge) lamp turns off when the battery is fully charged. Disconnect the AC Adaptor from the DC IN jack.

⚙ Notes

- Disconnect the AC Adaptor from the DC IN jack holding both the camcorder and the DC plug.

Step 2: Charging the battery pack (Continued)

To remove the battery pack

- 1 Turn the POWER switch to OFF (CHG).
- 2 Slide the BATT (battery) release lever (1) and remove the battery pack (2).

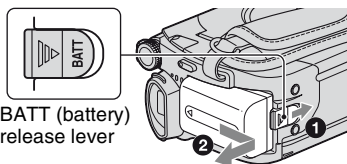

BATT (battery) release lever

Notes

- When you remove the battery pack or the AC Adaptor, make sure that the (Movie) lamp/ (Still) lamp (p. 25)/ACCESS lamp (p. 30)/access lamp (p. 32) are turned off.
- When you store the battery pack, fully discharge the battery before storing it for an extended period (p. 119).

To use a power source from a wall outlet (wall socket)

Make the same connections as you do when charging the battery pack. The battery pack will not lose its charge in this case.

To check the remaining battery (Battery Info)

Set the POWER switch to OFF (CHG), then press DISP/BATT INFO.

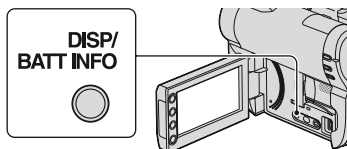

After a while, the approximate recordable time and battery information appear for about 7 seconds. You can view the battery information for up to 20 seconds by pressing DISP/BATT INFO again while the information is displayed.

Remaining battery (approx.)

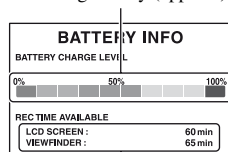

Recording capacity (approx.)

Charging time

Approximate time (min.) required when you fully charge a fully discharged battery pack.

Battery pack	Charging time
NP-FH40 (supplied)	125
NP-FH50	135
NP-FH70	170
NP-FH100	390

Recording time

Approximate time (min.) available when you use a fully charged battery pack.

When recording on the internal memory (DCR-DVD810) or a "Memory Stick PRO Duo"

DCR-DVD610

Battery pack	Continuous recording time	Typical recording time*
NP-FH40 (supplied)	110	50
	120	55
NP-FH50	130	60
	140	65
NP-FH70	280	130
	300	140
NP-FH100	625	300
	680	325

DCR-DVD710/DVD810

Battery pack	Continuous recording time	Typical recording time*
NP-FH40 (supplied)	95	45
	110	50
NP-FH50	110	50
	130	60
NP-FH70	235	110
	280	130
NP-FH100	535	255
	625	300

When recording on a disc**DCR-DVD610**

Battery pack	Continuous recording time	Typical recording time*
NP-FH40 (supplied)	95	40
	100	45
NP-FH50	110	45
	120	50
NP-FH70	235	105
	255	110
NP-FH100	535	240
	580	260

DCR-DVD710/DVD810

Battery pack	Continuous recording time	Typical recording time*
NP-FH40 (supplied)	80	35
	95	40
NP-FH50	95	40
	110	45
NP-FH70	205	90
	235	105
NP-FH100	470	210
	535	240

* Typical recording time shows the time when you repeat recording start/stop, turning the power on/off and zooming.

Notes

- See page 28 for selecting the media.
- All times measured with recording mode [SP] under the following conditions:
Top: When the LCD backlight turns on.
Bottom: When recording with the viewfinder while the LCD panel is closed.

Playing time

Approximate time (min.) available when you use a fully charged battery pack.

When playing the internal memory (DCR-DVD810) or a “Memory Stick PRO Duo”**DCR-DVD610**

Battery pack	LCD panel opened*	LCD panel closed
NP-FH40 (supplied)	150	170
	170	195
NP-FH70	370	415
NP-FH100	830	925

DCR-DVD710/DVD810

Battery pack	LCD panel opened*	LCD panel closed
NP-FH40 (supplied)	140	170
	165	195
NP-FH70	350	415
NP-FH100	785	925

Step 2: Charging the battery pack (Continued)

When playing a disc

DCR-DVD610

Battery pack	LCD panel opened*	LCD panel closed
NP-FH40 (supplied)	120	135
NP-FH50	140	155
NP-FH70	300	330
NP-FH100	680	745

DCR-DVD710/DVD810



Battery pack	LCD panel opened*	LCD panel closed
NP-FH40 (supplied)	115	135
NP-FH50	135	155
NP-FH70	290	330
NP-FH100	650	745

* When the LCD backlight is on.

⚡ Notes

- See page 28 for selecting the media.

On the battery pack

- Before changing the battery pack, turn the POWER switch to OFF (CHG) and turn off the  (Movie) lamp/  (Still) lamp (p. 25)/ ACCESS lamp (p. 30)/access lamp (p. 32).
- The CHG (charge) lamp flashes during charging, or Battery Info (p. 22) will not be correctly displayed under the following conditions:
 - The battery pack is not attached correctly.
 - The battery pack is damaged.
 - The battery pack is worn-out (for Battery Info only).
- The power will not be supplied from the battery as long as the AC Adaptor is connected to the DC IN jack of your camcorder, even when the power cord (mains lead) is disconnected from the wall outlet (wall socket).
- When attaching an optional video light, it is recommended that you use an NP-FH70/NP-FH100 battery pack (DCR-DVD710/DVD810).

- We do not recommend using an NP-FH30, which only allows short recording and playback times, with your camcorder.

On the charging/recording/playback time

- Times measured when using the camcorder at 25 °C (77 °F) (10 °C to 30 °C (50 °F to 86 °F) is recommended).
- The available recording and playback time will be shorter when you use your camcorder in low temperatures.
- The available recording and playback time will be shorter depending on the conditions under which you use your camcorder.

On the AC Adaptor

- Use the nearby wall outlet (wall socket) when using the AC Adaptor. Disconnect the AC Adaptor from the wall outlet (wall socket) immediately if any malfunction occurs while using your camcorder.
- Do not use the AC Adaptor placed in a narrow space, such as between a wall and furniture.
- Do not short-circuit the DC plug of the AC Adaptor or battery terminal with any metallic objects. This may cause a malfunction.
- Even if your camcorder is turned off, AC power source (mains) is still supplied to it while connected to the wall outlet (wall socket) via the AC Adaptor.

Step 3: Turning the power on, and setting the date and time

Set the date and time when using this camcorder for the first time. If you do not set the date and time, the [CLOCK SET] screen appears every time you turn on your camcorder or change the POWER switch position.

Touch the button on the LCD screen.

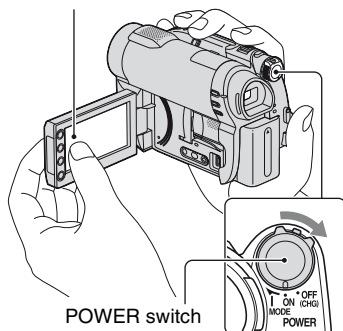

- 1 While pressing the green button, turn the POWER switch repeatedly in the direction of the arrow until the respective lamp lights up.

(Movie): To record movies

(Still): To record still images

Go to step 3 when you turn on your camcorder for the first time.

- 2 Touch (HOME) → (SETTINGS) → [CLOCK/ LANG] → [CLOCK SET].

The [CLOCK SET] screen appears.



- 3 Select the desired geographical area with /, then touch [NEXT].

- 4 Set [DST SET] or [SUMMERTIME], then touch [NEXT].

- 5 Set [Y] (year) with /.



- 6 Select [M] with /, then set the month with /.

- 7 Set [D] (day), hour and minute in the same way, then touch [NEXT].

- 8 Make sure that the clock is correctly set, then touch [OK].

The clock starts.

You can set any year up to the year 2037.

For midnight, set it to 12:00 AM.

For midday, set it to 12:00 PM.

To turn off the power

Turn the POWER switch to OFF (CHG).

Step 3: Turning the power on, and setting the date and time (Continued)

Notes

- If you do not use your camcorder for **about 3 months**, the built-in rechargeable battery gets discharged and the date and time settings may be cleared from the memory. In that case, charge the built-in rechargeable battery and then set the date and time again (p. 124).
- It takes a few seconds for your camcorder to be ready to shoot after the power is turned on. You cannot operate your camcorder during this time.
- In the default setting, the power turns off automatically if you leave your camcorder unoperated for approximately 5 minutes, to save battery power ([A.SHUT OFF], p. 89).

Tips

- The date and time does not appear during recording, but they are automatically recorded on the media, and can be displayed during playback ([DATA CODE], p. 84).
- See page 115 for information concerning "World time difference."
- If the buttons on the touch panel do not work correctly, adjust the touch panel ([CALIBRATION], p. 122).

Changing the language setting

You can change the on-screen displays to show messages in a specified language. Touch **HOME** → **SETTINGS** → **[CLOCK/ LANG]** → **[LANGUAGE SET]**, then select the desired language.

Step 4: Making adjustments before recording

Opening the lens cover

Slide the LENS COVER switch to OPEN.

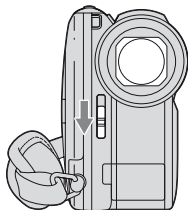

After recording, set the LENS COVER switch to CLOSE to close the lens cover.

Adjusting the LCD panel

Open the LCD panel 90 degrees to the camcorder (①), then rotate it to the best angle to record or play (②).

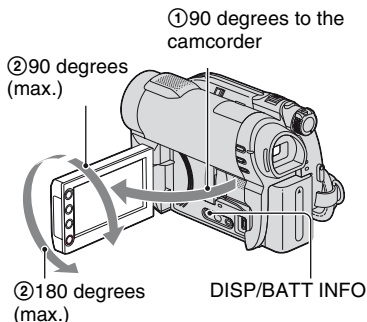

To turn off the LCD backlight to make the battery last longer (DCR-DVD710/DVD810)



Press and hold DISP/BATT INFO for a few seconds until **OFF** appears. This setting is practical when you use your camcorder in bright conditions or you want

to save battery power. The recorded image will not be affected by the setting. To turn on the LCD backlight, press and hold DISP/BATT INFO for a few seconds until  appears.

Notes

- Do not press the buttons on the LCD frame accidentally when you open or adjust the LCD panel.

Tips



- If you open the LCD panel 90 degrees to the camcorder, then rotate it 180 degrees to the lens side, you can close the LCD panel with the LCD screen facing out. This is convenient during playback operations.
- Touch  (HOME) →  (SETTINGS) → [SOUND/DISP SET] → [LCD BRIGHT] (p. 86), and adjust the brightness of the LCD screen.
- The information is displayed or hidden (display ↔ no display) each time you press DISP BATT/INFO.

Adjusting the viewfinder

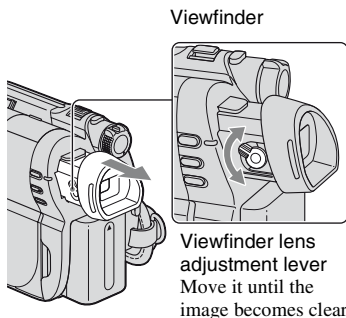
You can view images using the viewfinder to avoid wearing down the battery, or when the image seen on the LCD screen is poor. Pull out and look into the viewfinder. Adjust the viewfinder to your eyesight.



Tips

- You can adjust the brightness of the viewfinder backlight by touching  (HOME) →  (SETTINGS) → [SOUND/DISP SET] → [VF B.LIGHT] (p. 86).

Fastening the grip belt

Adjust and fasten the grip belt as illustrated, and hold your camcorder properly.

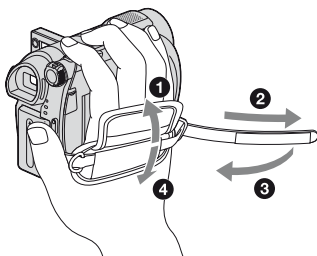

Step 5: Selecting media

You can set the media to be used for movies and still images separately.

For movies, you can select the internal memory*, a disc, or a "Memory Stick PRO Duo." For still images, you can select the internal memory*, or a "Memory Stick PRO Duo."

DCR-DVD610/DVD710

In the default setting, movies are recorded on a disc. Still images are recorded on a "Memory Stick PRO Duo" only.

DCR-DVD810

In the default setting, both movies and still images are recorded on the internal memory.

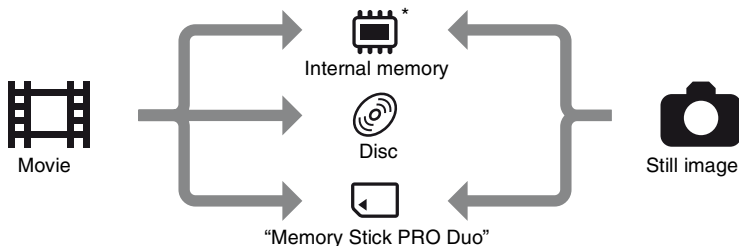

* DCR-DVD810

Notes

- You can record, play back, or edit images on the selected media. When you record, play back, or edit images on other media, select media again.

Selecting media for movies

- 1 Touch **HOME** → **MANAGE MEDIA** → **[MOVIE MEDIA SET]**.

The movie media setting screen appears.

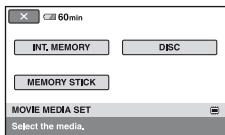

- 4 When **[Completed.]** appears, touch **[OK]**.

The movie media is changed.

- 2 Touch the desired media.

- 3 Touch **[YES]**.

Selecting media for still images (DCR-DVD810)

- 1 Touch **HOME** → **MANAGE MEDIA** → **[PHOTO MEDIA SET]**.

The still image media setting screen appears.

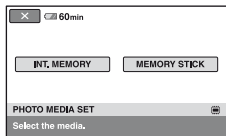

- 2 Touch the desired media.

Notes

- You cannot select a disc for the still image media.

- 3 Touch **[YES]**.

- 4 When **[Completed.]** appears, touch **[OK]**.

The still image media is changed.

To confirm the selected media

- ① Slide the POWER switch to turn on the lamp of the mode (**Movie**/**Still**) that you want to check the media.
- ② Confirm the media icon displayed at the upper right corner of the screen.

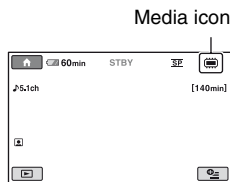

Internal memory*



Disc (The icon differs depending on the disc type (p. 13).)



"Memory Stick PRO Duo"

* DCR-DVD810

Step 6: Inserting a disc or a “Memory Stick PRO Duo”

When you select [INT. MEMORY] in “Step 5,” this “Step 6” operation is unnecessary (DCR-DVD810).

Inserting a disc

When you select [DISC] in “Step 5,” a new 8 cm DVD-RW, DVD+RW, DVD-R, or DVD+R DL is required (p. 13).

Notes

- Remove dust or fingerprints from the disc beforehand, using a soft cloth (p. 118).

1 Check that the power of your camcorder is on.

2 Slide the disc cover OPEN switch in the direction of the arrow (OPEN →).

[PREPARING TO OPEN] appears on the screen. The disc cover slightly opens automatically.

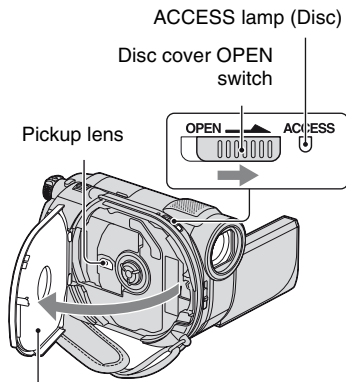

When the disc cover opens slightly, open it further.

3 Set the disc with the recording side facing your camcorder, then press the center of the disc until it clicks.

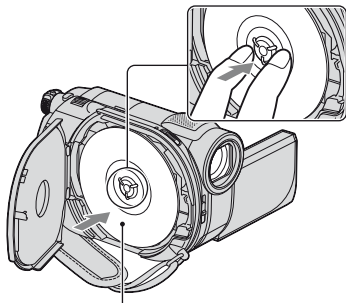

Set the disc with the label side facing out when using a single-sided disc.

4 Close the disc cover.

[DISC ACCESS] appears on the screen.

It may take some time for the camcorder to recognize the disc.

■ DVD-RW/DVD+RW

A screen appears to ask whether you will use [DISC SELECT GUIDE]. Using [DISC SELECT GUIDE] lets you format the disc by following the guidance on the screen. If you do not want to use it, proceed to step 5.

■ DVD-R/DVD+R DL

You can start recording immediately after [DISC ACCESS] disappears from the screen. You do not need to proceed to steps after step 5.

5 Touch the option that is right for you on the screen.

■ DVD-RW

Select the recording format, [VIDEO] or [VR] (p. 13), then touch **[OK]**.

■ DVD+RW

Select the aspect ratio of the movie, [16:9 WIDE] or [4:3], then touch **[OK]**.

6 Touch [YES].

7 When [Completed.] is displayed, touch **[OK]**.

When the formatting is completed, you can start recording on the disc.

💡 Tips

- When you use a DVD-RW while the Easy Handycam operation (p. 34) is set, the recording format is fixed to VIDEO mode.

To remove the disc

- ① Perform steps **1** and **2** to open the disc cover.
- ② Press the disc holder in the center of the disc compartment, and remove the disc by holding the edge.

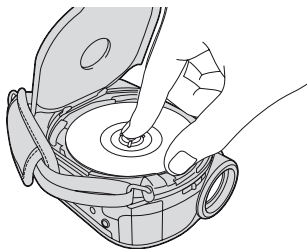

📌 Notes

- Be careful not to obstruct the operation with your hand or other objects, when opening or closing the disc cover. Move the grip belt to the bottom of the camcorder, then open or close the disc cover.
- If you catch the grip belt when closing the disc cover, it may cause your camcorder to malfunction.
- Do not touch the disc with the recording side or pickup lens (p. 123). When using a double-sided disc, take care not to smudge the surface with fingerprints.
- If you close the disc cover with the disc set incorrectly, it may cause your camcorder to malfunction.
- Do not disconnect the power sources while formatting a disc.
- Do not apply shock or vibration to your camcorder since your camcorder is reading/writing on the disc:
 - while the ACCESS lamp is on
 - while the ACCESS lamp is flashing
 - while [DISC ACCESS] or [PREPARING TO OPEN] is displayed on the LCD screen
- It may take some time to remove the disc depending on the recorded contents.
- It may take about 10 minutes to remove a disc if the disc has scratches or is dirty with fingerprints, etc. In that case, the disc might be damaged.

💡 Tips

- You can insert or remove the disc when a power source is connected to your camcorder even when your camcorder is turned off. However, the disc recognition process (step **4**) does not start.
- To delete all of the previously recorded images from a DVD-RW/DVD+RW, then to use it again to record new images, see “Formatting media” (p. 72).
- You can check the right disc using [DISC SELECT GUIDE] on the HOME MENU (p. 75).

Step 6: Inserting a disc or a “Memory Stick PRO Duo” (Continued)

Inserting a “Memory Stick PRO Duo”

This operation is necessary only when you select [MEMORY STICK] in “Step 5.” See page 6 on the “Memory Stick” you can use with your camcorder.

Tips

- If you record only still images on the “Memory Stick PRO Duo,” operations after step 3 are unnecessary.

1 Open the LCD panel.

2 Insert the “Memory Stick PRO Duo.”

- 1 Open the Memory Stick Duo cover in the direction of the arrow.
- 2 Insert the “Memory Stick PRO Duo” into the Memory Stick Duo slot in the right direction until it clicks.
- 3 Close the Memory Stick Duo cover.

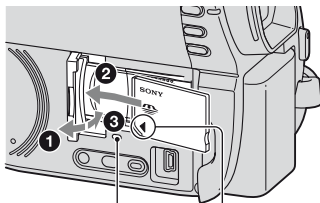

Access lamp

Face the ◀ mark towards the LCD screen.

3 If you select [MEMORY STICK] in “Step 5” for movie recording, slide the POWER switch repeatedly until the (Movie) lamp lights up.

If the POWER switch is set to OFF (CHG), turn it on while pressing the green button.

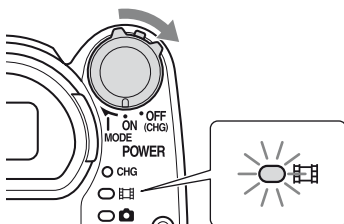

The [Create a new Image Database File.] screen appears on the screen when you insert a new “Memory Stick PRO Duo.”

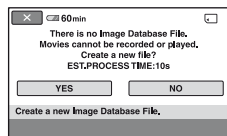

4 Touch [YES].



To remove the “Memory Stick PRO Duo”

Open the LCD panel and Memory Stick Duo cover. Lightly push the “Memory Stick PRO Duo” in once, then slide it out of the slot.

Notes

- To prevent media from being broken or recorded images from being lost, do not do the following when the access lamp (p. 32) is on:
 - to remove the battery pack or AC Adaptor from the camcorder
 - to apply mechanical shock or vibration to the camcorder
 - to remove the “Memory Stick PRO Duo” from the camcorder
- Do not open the Memory Stick Duo cover during recording.
- Inserting a “Memory Stick PRO Duo” forcibly in the wrong direction may cause a malfunction to the “Memory Stick PRO Duo,” Memory Stick Duo slot, or image data.
- If [Failed to create a new Image Database File. It may be possible that there is not enough free space.] is displayed in step 4, format the “Memory Stick PRO Duo” (p. 72). All recorded data on the “Memory Stick PRO Duo” will be deleted when you format.
- Do not pinch and remove the “Memory Stick PRO Duo” forcibly. It may cause a malfunction.

Recording time of movies on a “Memory Stick PRO Duo”

Figures in the table are approximate recording time in minutes of “Memory Stick PRO Duo.”

Figures in () are minimum recording time.

Recording mode	9M (HQ) (high quality)	6M (SP) (standard quality)	3M (LP) (long play)
512MB	6 (5)	9 (5)	15 (10)
1GB	10 (10)	20 (10)	35 (25)
2GB	25 (25)	40 (25)	80 (50)
4GB	55 (50)	80 (50)	160 (105)
8GB	115 (100)	170 (100)	325 (215)

Notes

- Numbers in the table are of when using a “Memory Stick PRO Duo” made by Sony Corporation. The recordable time varies depending on the recording conditions, the type of “Memory Stick,” or the [REC MODE] setting (p. 80).
- When the recordable time is less than 5 minutes,  appears.

Tips

- See page 83 for the recordable numbers of still images.



Recording and playing back with ease (Easy Handycam operation)

Easy Handycam operation makes nearly all settings automatic so that you can perform recording or playing back operation without detailed settings. It also makes the screen font size larger for easy viewing. The images are recorded on the selected media (p. 28).

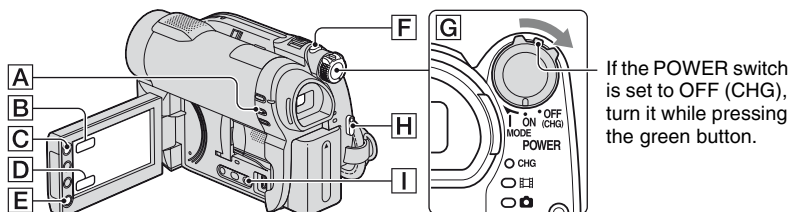

Movies



- 1 Turn the POWER switch **G** until the  (Movie) lamp lights up.



- 2 Press EASY **A**.



- 3 Press START/STOP **H** (or **E**) to start recording*.

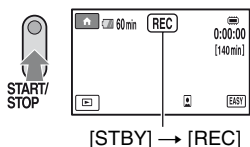

To stop recording, press START/STOP again.

Still Images



- 1 Turn the POWER switch **G** until the  (Still) lamp lights up.



- 2 Press EASY **A**.



- 3 Press PHOTO **F** lightly to adjust the focus **A** (a beep sounds), then press it fully **B** (a shutter click sounds).

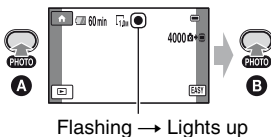

* Movies are recorded in the [SP] recording mode.

Playing back recorded movies/still images

1 Turn the POWER switch **[G]** to turn on your camcorder.

2 Press **[VIEW IMAGES]** **[I]** (or **[D]**).

The VISUAL INDEX screen appears on the screen. (It may take some time to display the thumbnails.)

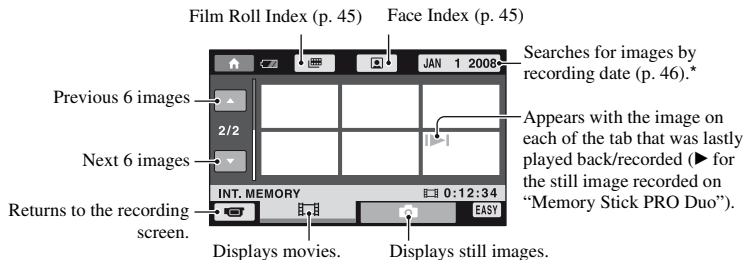

* When you select [DISC] on [MOVIE MEDIA SET] (p. 28), a disc type appears. You cannot search for movies by recording date.

3 Start playback.

Movies:



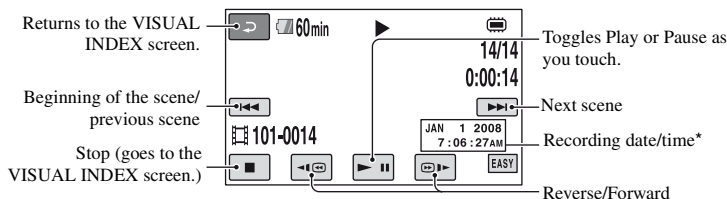



Touch the **[MOVIE]** tab and the movie to be played back.



* The setting of [DATA CODE] is fixed to [DATE/TIME] (p. 84).

Recording and playing back with ease (Easy Handycam operation) (Continued)

💡 Tips

- When playback from the selected movie reaches the last movie, the screen returns to the VISUAL INDEX screen.
- You can slow down the playback speed by touching  /  during pause.
- You can adjust the volume by touching  (HOME) →  (SETTINGS) → [SOUND SETTINGS] → [VOLUME], then with  / .
- You can change the movie media with [MOVIE MEDIA SET] (p. 28).

Still images:

Touch the  tab and the still image to be played back.

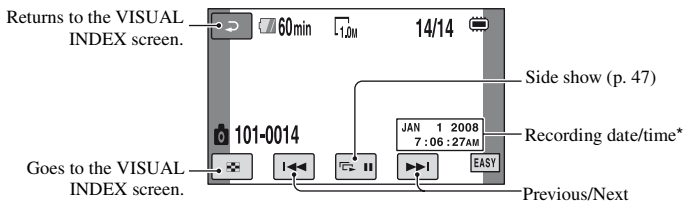

* The setting of [DATA CODE] is fixed to [DATE/TIME] (p. 84).

💡 Tips

- You can switch the still image media with [PHOTO MEDIA SET] (DCR-DVD810) (p. 28).

To cancel Easy Handycam operation

Press EASY [A] again. EASY disappears from the screen.

Menu settings during Easy Handycam operation

Touch  (HOME) [C] (or [B]) to display the menu items available for setup changes (p.17, 78).

Notes

- Most of the menu items automatically return to the default settings. The settings of some menu items are fixed. For details, see page 79.
- DVD-RW is formatted with VIDEO mode (p. 13).
- You cannot use the  (OPTION) menu.
- Cancel Easy Handycam operation if you want to add effects to images or change settings.

Invalid buttons during Easy Handycam operation

You cannot use some buttons/functions during Easy Handycam operation since they are automatically set (p. 79). If you set an invalid operation, [Invalid during Easy Handycam operation] appears.

To view movies on a disc on other devices (Finalize)

To view movies stored on a disc on other devices or a computer, you need to “finalize” the disc. For details on finalizing operation, see page 67.

Notes

- For DVD-R, DVD+R DL, you cannot reuse the disc or record additional movies onto the disc once you finalize the disc even if the disc has free space.
- You cannot record additional movies on a finalized disc during Easy Handycam operation (p. 74).

Recording

The images are recorded on the media selected on the media setting (p. 28).

DCR-DVD610/DVD710

In the default setting, movies are recorded on a disc. Still images are recorded on a “Memory Stick PRO Duo” only.

DCR-DVD810

In the default setting, both movies and still images are recorded on the internal memory.

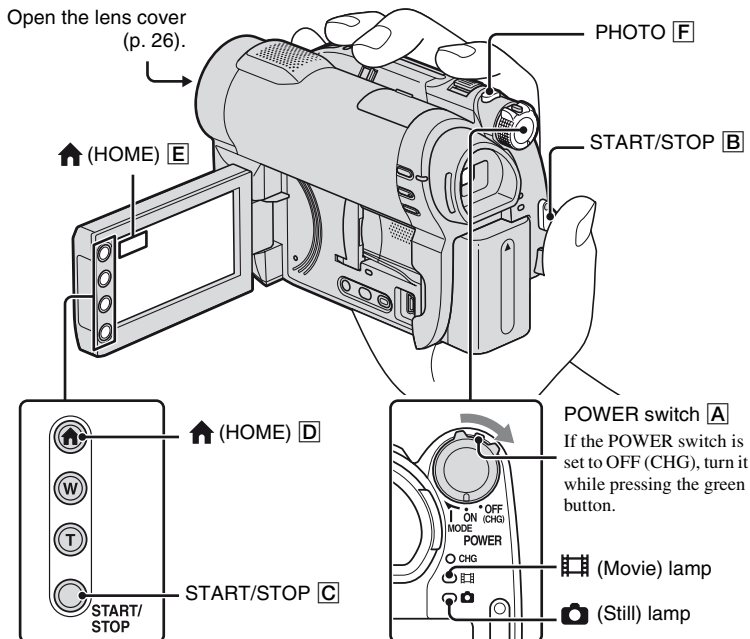

⚡ Notes

- If the ACCESS/access lamps (p. 30, 32) are lit or flashing after recording is finished, it means data is still being written onto the media. Do not apply shock or vibration to your camcorder, and do not remove the battery pack or the AC Adaptor.
- In the case that [INT. MEMORY] (DCR-DVD810) or [MEMORY STICK] is selected on [MOVIE MEDIA SET] (p. 28), when a movie file exceeds 2 GB, the next movie file is created automatically.

💡 Tips

- See page 6 for the “Memory Stick PRO Duo” you can use in your camcorder.
- You can check the free media space for movies by touching ↑ (HOME) → 🗂️ (MANAGE MEDIA) → [MEDIA INFO] (p. 71).

Movies



- 1 Turn the POWER switch **A** until the (Movie) lamp lights up.

- 2 Press START/STOP **B** (or **C**).

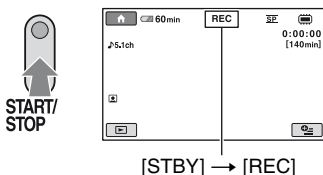

To stop recording, press START/STOP again.

Still Images



- 1 Turn the POWER switch **A** until the (Still) lamp lights up.

- 2 Press PHOTO **F** lightly to adjust the focus **A** (a beep sounds), then press it fully **B** (a shutter click sounds).

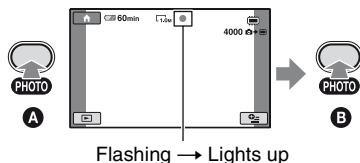

appears next to or . When disappears, the image has been recorded.

Notes

- You cannot record still images on a disc.

Tips

- See page 14 for the recordable time of movies, and page 83 for the number of recordable still images.
- appears when [INDEX SET] is set to [ON] (the default setting) during movie recording (p. 82).
- You can switch recording between movies and still images by touching (HOME) **D** (or **E**) → (CAMERA) → [MOVIE] or [PHOTO].
- You can create still images from recorded movies (p. 53).

Recording (Continued)

Zooming

You can zoom in up to the magnifications shown in the following table.

	(optical zoom)
DCR-DVD610	40 ×
DCR-DVD710/DVD810	25 ×

You can adjust the magnification with the power zoom lever or the zoom button on the LCD frame.

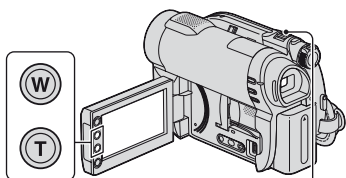

Wider range of view:
(Wide angle)

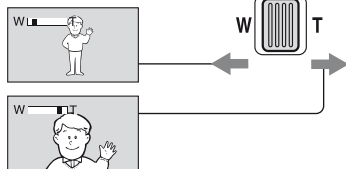

Close view: (Telephoto)

Move the power zoom lever slightly for a slower zoom. Move it further for a faster zoom.

Notes

- [STEADYSHOT] may not reduce image blurring as desired when the power zoom lever is set to the T (Telephoto) side.
- Be sure to keep your finger on the power zoom lever. If you move your finger off the power zoom lever, the operation sound of the lever may also be recorded.
- You cannot change the zoom speed with the zoom buttons on the LCD frame.
- The minimum possible distance between camcorder and subject while maintaining sharp

focus is about 1 cm (about 13/32 in.) for wide angle and about 80 cm (about 2 5/8 feet) for telephoto.

Tips

- Using [DIGITAL ZOOM] (p. 81), you can zoom in further than the magnification shown in the table when recording movies.

Recording sound with more presence (5.1ch surround recording) (DCR-DVD710/DVD810)

Sound picked up by the built-in microphone is converted to 5.1ch surround sound and recorded.

Enjoy realistic sound when playing the movies on devices that support 5.1ch surround sound.

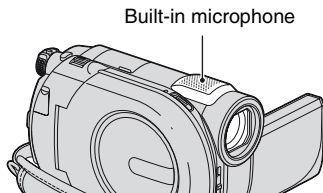

Dolby Digital 5.1 Creator, 5.1ch surround sound
Glossary (p. 135)

Notes

- 5.1ch sound is converted to 2ch when played back on your camcorder.

Tips

- You can select the recording sound, [5.1ch SURROUND] or [2ch STEREO] ([AUDIO MODE]), p. 80).

Starting to record quickly (QUICK ON)

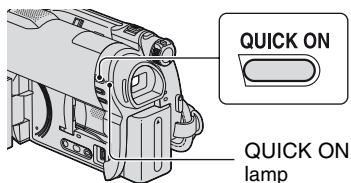



If you press QUICK ON instead of turning off the POWER switch, the power consumption will be reduced (sleep mode). In sleep mode, the QUICK ON lamp flashes. If you press QUICK ON again when you want to start next recording, your camcorder will be ready for recording after about 1 second.

Notes

- While the camcorder is in sleep mode, the power consumption will be about half that used during recording. You can save the battery power.
- If you do not operate your camcorder and leave it in sleep mode for a while, your camcorder automatically turns off. With [QUICK ON STBY], you can set the time after which the camcorder turns off in sleep mode (p. 89).
- If you press QUICK ON during recording, your camcorder stops recording and becomes sleep mode.

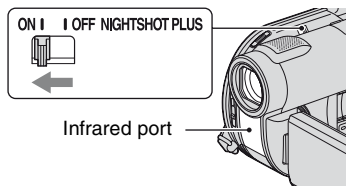
Recording in dark places (NightShot plus)



To record in dark places, set the NIGHTSHOT PLUS switch to ON to display .

Notes



- The NightShot plus and Super NightShot plus functions use infrared light. Therefore, do not cover the infrared port with your fingers or other objects.
- Remove the conversion lens (optional).
- Adjust the focus manually ([FOCUS], p. 92) when it is hard to focus automatically.
- Do not use the NightShot plus and Super NightShot plus functions in bright places. This may cause a malfunction.

Tips

- To record an image brighter, use Super NightShot plus function (p. 95). To record a movie more faithfully to the original colors, use Color Slow Shutter function (p. 95).

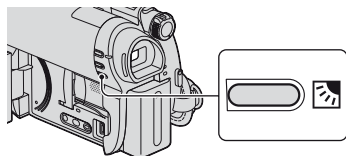
Adjusting the exposure for backlit subjects



To adjust the exposure for backlit subjects, press  (BACK LIGHT) to display . To cancel the back light function, press  (BACK LIGHT) again.

Recording in mirror mode

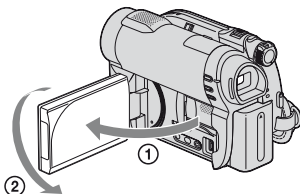

Recording (Continued)

Open the LCD panel 90 degrees to the camcorder (①), then rotate it 180 degrees to the lens side (②).

Tips

- A mirror-image of the subject appears on the LCD screen, but the image will be normal when recorded.
- When recording in mirror mode, the images are not displayed in the viewfinder.

Playback

You can play back images recorded on the media selected in the media setting (p. 28).

DCR-DVD610/DVD710

In the default setting, movies on a disc are played. Still images are recorded and played on a "Memory Stick PRO Duo" only.

DCR-DVD810

In the default setting, images in the internal memory are played.

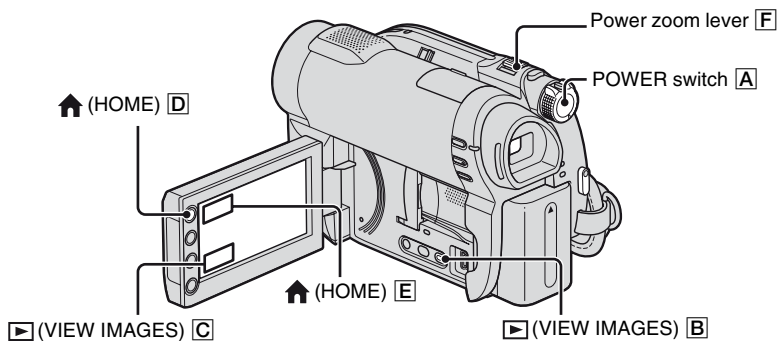

1 Turn the POWER switch **A** to turn on your camcorder.

2 Press **VIEW IMAGES** **B** (or **C**).

The VISUAL INDEX screen appears on the screen. (It may take some time to display the thumbnails.)

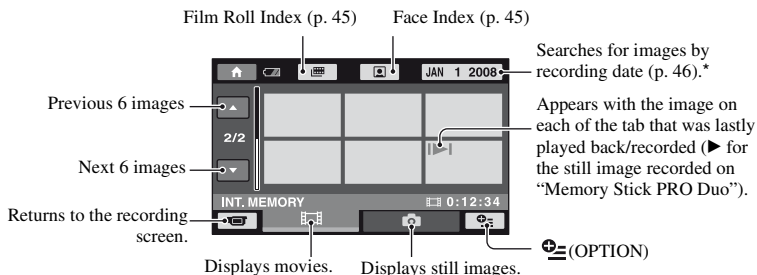

* When you select [DISC] on [MOVIE MEDIA SET] (p. 28), a disc type appears. You cannot search for movies by recording date.

Playback (Continued)

💡 Tips

- The number of the images on the VISUAL INDEX screen can be changed 6 ↔ 12 by moving the power zoom lever [F]. To fix this number, touch ⬆️ (HOME) [D] (or [E]) → 📷 (SETTINGS) → [VIEW IMAGES SET] → [📷 DISPLAY] (p. 85).

3 Start playback.

Movies



Touch the 📺 tab and the movie to be played back.

When playback from the selected movie reaches the last movie, the screen returns to the VISUAL INDEX screen.

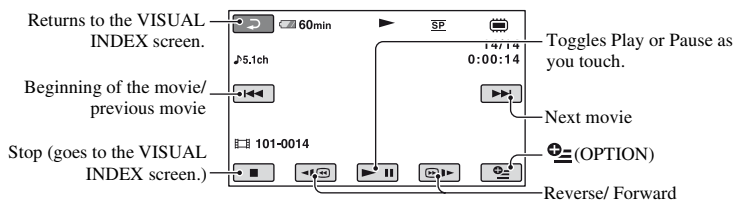

💡 Tips

- Touch ◀️Ⓜ️/Ⓜ️▶️ during pause to play back movie slowly.
- When playing movies from the internal memory (DCR-DVD810) or from a “Memory Stick PRO Duo,” one touch of ◀️Ⓜ️/Ⓜ️▶️ makes the movie reverse/fast forward about 5 times faster than normal, 2 touches about 10 times, 3 touches about 30 times, and 4 touches about 60 times faster.
- When playing the movies on a disc, one touch of ◀️Ⓜ️/Ⓜ️▶️ makes the movie reverse/fast forward about 5 times faster than normal, 2 touches about 10 times faster (about 8 times faster for a DVD+RW).

Still Images



Touch the 📷 tab and the still image to be played back.

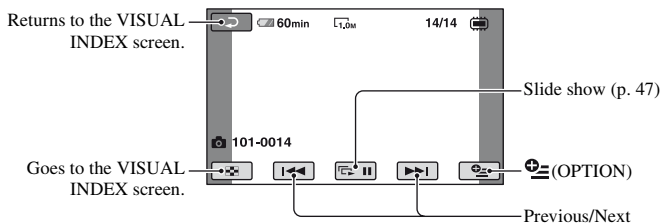

To adjust the sound volume of movies

While playing back movies, touch OPTION → VIEW IMAGES tab → [VOLUME], then adjust the volume with [-] / [+] .

💡 Tips

- You can switch screen to the VISUAL INDEX screen by touching HOME [D] (or [E]) → VIEW IMAGES → [VISUAL INDEX].

Searching for scenes with pinpoint accuracy (Film Roll Index)

Movies can be divided by a set time, and the first scene of each division is displayed on the INDEX screen. You can start playing back a movie from the selected scene. Select beforehand media which contains the movie you want to play back (p. 28).

1 Press VIEW IMAGES (VIEW IMAGES) on your camcorder.

The VISUAL INDEX screen appears.

2 Touch FILM ROLL INDEX (Film Roll Index).

Previous/Next movie

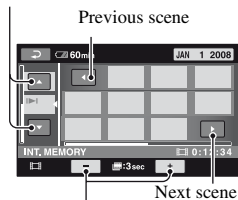

Changes the interval of scenes.

3 Touch UP/DOWN to select the desired movie.

4 Touch LEFT/RIGHT to search for the desired scene.

Playback starts from the selected scene.

💡 Tips

- You can display the Film Roll Index screen by touching HOME → VIEW IMAGES → [INDEX].

Searching for desired scenes by a face (Face Index)

The detected face images during recording are displayed on the INDEX screen.

You can play back the movie from the selected face image.

Select beforehand media which contains the movie you want to play back (p. 28).

1 Press VIEW IMAGES (VIEW IMAGES) on your camcorder.

The VISUAL INDEX screen appears.

2 Touch FACE INDEX (Face Index).

Previous/Next movie

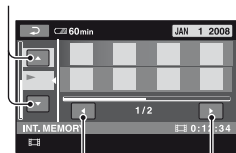

Previous/Next face image

3 Touch UP/DOWN to select the desired movie.

- 4 Touch / to search for the desired face image, then select the face image of the scene you want to play back.

Playback starts from the selected scene.

Notes

- Faces may not be detected depending on recording conditions.
Example: People wearing glasses or hats, or not facing towards the camera.
- Set [INDEX SET] to [ON] (the default setting) before recording to play back movies from [INDEX] (p. 82). Face Index may not appear properly if no face was detected.

Tips

- You can display the Face Index screen by touching (HOME) → (VIEW IMAGES) → [INDEX].

Searching for desired images by date (Date Index)



You can efficiently search for desired images by date.
Select beforehand media which contains the movie you want to play back (p. 28).

Notes

- You cannot use the Date Index with the disc, and still images on the “Memory Stick PRO Duo.”

- 1 Press (VIEW IMAGES) on your camcorder.

The VISUAL INDEX screen appears.

- 2 To search for movies, touch the tab. To search for still images, touch the tab.

- 3 Touch the date button at the upper right corner of the screen.

The recording dates of images are displayed on the screen.

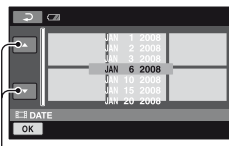

Previous/Next date

- 4 Touch / to select the recording date of the desired images, then touch .

The images recorded on the selected date are displayed on the screen.

Tips

- On the Film Roll Index screen or the Face Index screen, you can display the Date Index function by following the steps 3 to 4.

Using PB zoom

You can magnify still images from about 1.1 to 5 times the original size. Magnification can be adjusted with the power zoom lever or the zoom buttons on the LCD frame.

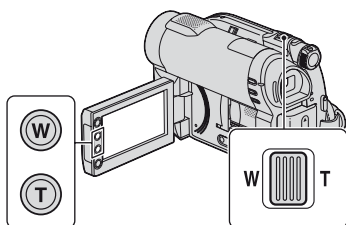

- ① Play back the still image you want to magnify.
- ② Magnify the still image with T (Telephoto).
The screen is framed.
- ③ Touch the screen at the point you want to display in the center of the displayed frame.
- ④ Adjust the magnification with W (Wide angle)/T (Telephoto).

To cancel, touch

Playing back a series of still images (Slide show)

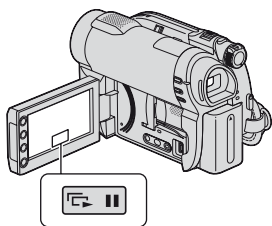

Touch on the still image playback screen.
The slide show begins from the selected still image.
Touch to stop the slide show. To restart, touch again.

Notes

- You cannot operate playback zoom during slide show.

Tips

- You can also play back the slide show by touching (OPTION) → tab → [SLIDE SHOW] on the VISUAL INDEX screen.
- While playing back still images, you can set continuous slide show playback by touching (OPTION) → tab → [SLIDE SHOW SET]. As the default setting is [ON], is displayed on the LCD screen and your camcorder repeats a slide show of still images. If you set [SLIDE SHOW SET] to [OFF], your camcorder plays the still images in slide show mode once, starting from the selected still image.

Playing the images on a TV

Connect your camcorder to the input jack of a TV or VCR using the A/V connecting cable **1** or an A/V connecting cable with S VIDEO **2**. Connect your camcorder to the wall outlet (wall socket) using the supplied AC Adaptor for this operation (p. 21). Refer also to the instruction manuals supplied with the devices to be connected.

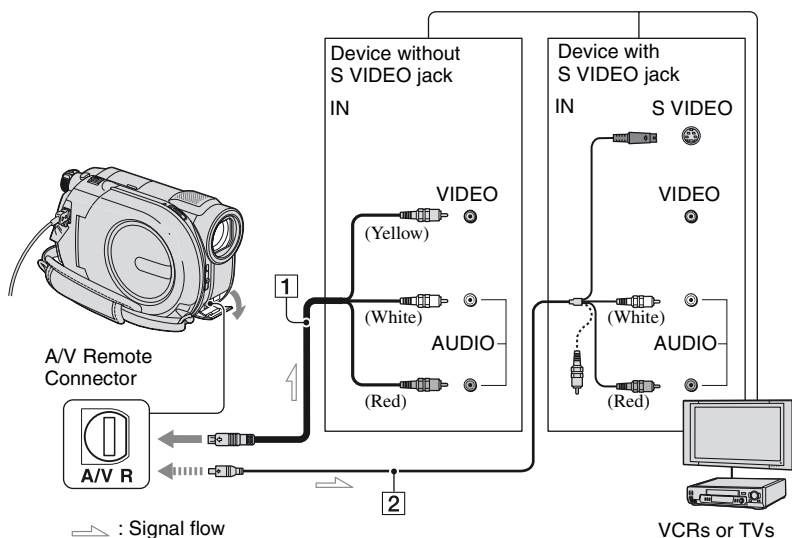

1 A/V connecting cable (supplied)

Connect to the input jack of the other device.

2 A/V connecting cable with S VIDEO (optional)

When connecting to the other device via the S VIDEO jack, by using an A/V connecting cable with S VIDEO (optional), higher quality images can be produced than with an A/V connecting cable. Connect the white and red plugs (left/right audio) and the S VIDEO plug (S VIDEO channel) of the A/V connecting cable with S VIDEO (optional). The yellow plug connection is not necessary. Connecting only the S VIDEO plug will not output audio.

When your TV is connected to a VCR

Connect your camcorder to the LINE IN input on the VCR. Set the input selector on the VCR to LINE (VIDEO 1, VIDEO 2, etc.), if the VCR has an input selector.

To set the aspect ratio according to the connected TV (16:9/4:3)

Change the setting according to the screen aspect ratio of the TV you will view images on.

- ① Turn on your camcorder.
- ② Touch **HOME** (HOME) → **SETTINGS** (SETTINGS) → [OUTPUT SETTINGS] → [TV TYPE] → [16:9] or [4:3] → **OK**.

Notes

- When you connect your camcorder to a TV compatible with the ID-1/ID-2 system, set [TV TYPE] to [16:9]. The TV switches to full mode automatically. Refer also to the instruction manuals supplied with your TV.
- When you set [TV TYPE] to [4:3], the image quality may deteriorate. Also, when the recorded image's aspect ratio switches between 16:9 (wide) and 4:3, the image may jitter.
- When you play back an image recorded in 16:9 (wide) aspect ratio on a 4:3 TV not compatible with the 16:9 (wide) signal, set [TV TYPE] to [4:3].

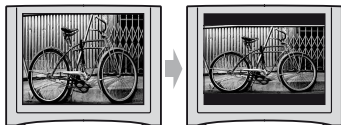

When your TV is monaural (When your TV has only one audio input jack)

Connect the yellow plug of the A/V connecting cable to the video input jack and connect the white (left channel) or the red (right channel) plug to the audio input jack of your TV or VCR.

Tips

- You can display the counter on the TV screen by setting [DISP OUTPUT] to [V-OUT/PANEL] (p. 87).



(OTHERS) category

This category enables you to edit or print images on the media, or copy them onto your computer for viewing, editing or creating an original DVD.



 (OTHERS) category

Notes

- You can select the media of the image to be edited by touching  (HOME) →  (MANAGE MEDIA) → [MOVIE MEDIA SET]/[PHOTO MEDIA SET] (p. 28).

Item list

DELETE

You can delete images on the media (p. 51).

PHOTO CAPTURE

You can capture a selected scene from a recorded movie as a still image (p. 53).

MOVIE DUB

You can dub movies recorded on the internal memory (DCR-DVD810) or a “Memory Stick PRO Duo” to a disc (p. 55).

PHOTO COPY (DCR-DVD810)

You can copy still images recorded on the internal memory to a “Memory Stick PRO Duo” (p. 56).

EDIT

You can edit the images on the media (p. 58).

PLAYLIST EDIT

You can create and edit a Playlist (p. 59).

PRINT

You can print still images on a connected PictBridge printer (p. 64).

USB CONNECT

You can connect your camcorder to a computer or another device using the USB cable (p. 97).

Deleting images

Notes

- You cannot restore images once they are deleted.

Tips

- You can select up to 100 images at one time.

Deleting movies



Select beforehand the media which contains the movie you want to delete (p. 28).

Notes

- When you select [DISC] on [MOVIE MEDIA SET] (p. 28), you cannot delete movies during Easy Handycam operation (p. 34). Cancel Easy Handycam operation first.

1 Touch (HOME) → (OTHERS) → [DELETE].

2 Touch [DELETE].

3 Touch [DELETE].

4 Touch the movie to be deleted.

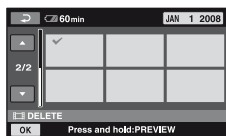

The selected movie is marked with . Press and hold the movie on the screen to confirm.

Touch to return to the previous screen.

5 Touch [OK] → [YES].

6 When [Completed.] appears, touch [OK].

To delete all movies at one time



- In step 3, touch [DELETE ALL].
- Touch [YES] → [YES].
- When [Completed.] appears, touch [OK].

To delete all the movies recorded on the same day at one time



- In step 3, touch [DELETE by date].

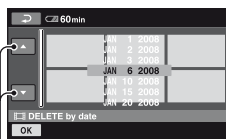

Previous/Next date

- Touch to select the recording date of the desired movies, then touch [OK].

The movies recorded on the selected date are displayed on the screen.

Touch the movie on the screen to confirm.

Touch to return to the previous screen.

- Touch [OK] → [YES].
- When [Completed.] appears, touch [OK].

Deleting images (Continued)

To delete the most recently recorded movie



- 1 In step **3**, touch [LAST SCENE DEL].
- 2 Touch [OK] → [YES].
- 3 When [Completed.] appears, touch [OK].

You cannot delete the most recently recorded movie:

- if you remove the disc from your camcorder after recording.
- if you turn off your camcorder after recording.

Notes

- Do not remove the battery pack or the AC Adaptor from your camcorder while deleting movies.
- Do not remove the “Memory Stick PRO Duo” while deleting movies from the “Memory Stick PRO Duo.”
- If the deleted movie is included in a Playlist (p. 59), the movie is deleted also from the Playlist.
- You cannot delete movies from the “Memory Stick PRO Duo” if the movies are protected by another device.
- Even if you delete unnecessary movies from the disc, the remaining disc capacity may not increase as much as you can make additional recording.

Tips

- To delete all images recorded on the media and recover all the recordable space of the media, format the media (p. 72).
- You can delete a movie when viewing it by touching (OPTION).

Deleting still images



Select beforehand the media which contains the still image you want to delete (p. 28).

-
- 1 Touch (HOME) → (OTHERS) → [DELETE].

-
- 2 Touch [DELETE].

-
- 3 Touch [DELETE].

-
- 4 Touch the still image to be deleted.

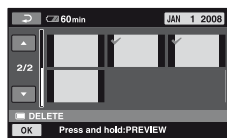

The selected still image is marked with .

Press and hold the still image on the screen to confirm.

Touch to return to the previous screen.

-
- 5 Touch [OK] → [YES].

-
- 6 When [Completed.] appears, touch [OK].

To delete all still images at one time



- 1 In step **3**, touch [DELETE ALL].
- 2 Touch [YES] → [YES].
- 3 When [Completed.] appears, touch [OK].

To delete all the still images recorded on the same day at one time



- ① In step 3, touch [DELETE by date].

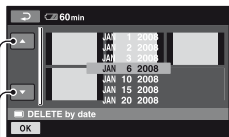

Previous/Next date

- ② Touch / to select the recording date of the desired still images, then touch .

The still images recorded on the selected date are displayed on the screen.

Touch the still image on the screen to confirm.

Touch to return to the previous screen.

- ③ Touch → [YES].
- ④ When [Completed.] appears, touch .

Notes

- You cannot delete still images from the “Memory Stick PRO Duo” if the still images are protected by another device.

Tips

- To delete all images recorded in the internal memory (DCR-DVD810) or a “Memory Stick PRO Duo,” and recover all the recordable space of the media, format the media (p. 72).
- You can delete a still image when viewing it by touching (OPTION).

Capturing a still image from a movie

You can capture a still image at any point during movie playback.

Select the media which contains the movies beforehand, and the media where you want to save the still images (p. 28).

When you select [MEMORY STICK] to save the still images, insert a “Memory Stick PRO Duo” beforehand.

The media you can select depends on your camcorder model. See the table below.

Model	Movies in	Still images in
DCR-DVD610/ DVD710	→	
	→	
DCR-DVD810	→	
	→	
	→	
	→	
	→	
	→	

Notes

- Using the AC Adaptor as the power source is recommended to prevent the power from being turned off during operation.

1 Touch (HOME) → (OTHERS) → [PHOTO CAPTURE].

The [PHOTO CAPTURE] screen appears.

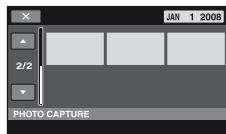

2 Touch the movie that you want to play back and capture an image from.

The selected movie is played back.

3 Touch to pause at the point where you want to capture.

The movie pauses.

Play and pause toggles as you press



Adjusts the capturing point with more precision after the capturing point has been selected with .

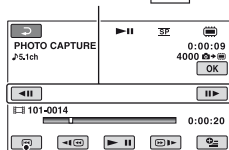

Returns to the beginning of the selected movie.

4 Touch .

 appears while the still image is captured and stored on the media you selected.

To capture another still image, touch



and repeat from step 2.

To finish the operation, touch  →









Notes

- The media where you want to save still images has to have enough free space.
- Recording date and time of created still images are the same as the recording date and time of the movies.
- If the movies do not have data code, recording date and time of still images are saved as the time you create them from the movies.

Dubbing/copying images to media within your camcorder

Dubbing movies

You can dub movies from the internal memory (DCR-DVD810) or a “Memory Stick PRO Duo” to a disc. Insert a disc in your camcorder beforehand. The media you can select depends on your camcorder model. See the table below.



Model	From	To
DCR-DVD610/ DVD710	 → 	
DCR-DVD810	 → 	
	 → 	

Notes

- Using the AC Adaptor as the power source is recommended to prevent the power from being turned off during operation.

Tips

- To check dubbed movies on the disc, select [DISC] on [MOVIE MEDIA SET] (p. 28).

- 1 Touch  (HOME) →  (OTHERS) → [MOVIE DUB]. Or, press DUBBING on your camcorder (DCR-DVD810).

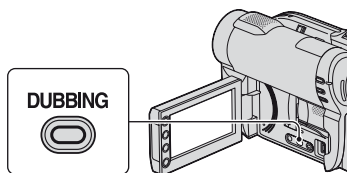

The [MOVIE DUB] screen appears.

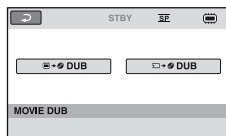

- 2 DCR-DVD810:
Touch media which contains the movie to be dubbed.

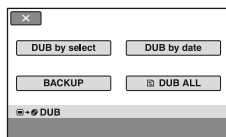

DCR-DVD610/DVD710:



Step 2 is unnecessary. Go to step 3.

- 3 Touch [DUB by select].

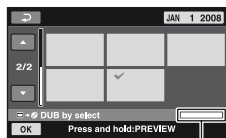
- 4 Touch the movie to be dubbed.



Remaining disc space*

- * : Used
-  (green): To be used to save the selected movie
- : Free space

The selected movie is marked with . Press and hold the movie on the screen to confirm.

Touch  to return to the previous screen.

Dubbing/copying images to media within your camcorder (Continued)

If the disc space is not sufficient to record the entire movie, [Not enough memory space.] appears.

5 Touch [OK] → [YES].

6 When [Completed.] appears, touch [OK].

To dub all the movies recorded on the same day at one time

- 1 In step 3, touch [DUB by date].

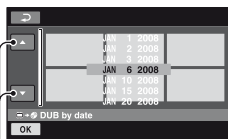

Previous/Next date

- 2 Touch [▲]/[▼] to select the recording date of the desired movies, then touch [OK].

The movies recorded on the selected date are displayed on the screen.

Touch the movie on the screen to confirm.

Touch [◀] to return to the previous screen.

- 3 Touch [OK] → [YES].
If the disc space is not sufficient to record the entire movie, [Not enough memory space.] appears.
- 4 When [Completed.] appears, touch [OK].

To dub all movies in a Playlist (p. 59)

- 1 In step 3, touch [DUB ALL].
If the disc space is not sufficient to record the entire movie, [Not enough memory space.] appears.

- 2 Touch [YES].
- 3 When [Completed.] appears, touch [OK].

To back up movies that have not been backed up yet

- 1 In step 3, touch [BACKUP].
- 2 Touch [Backs up unbacked up movies.] → [YES].
- 3 When [Completed.] appears, touch [OK].
If the disc space is not sufficient to record the entire movie, [Disc is full.] appears, and the number of one-sided discs required will be displayed. Prepare discs, and repeat from step 1.

Notes

- If movies are backed up on 2 or more discs, the movie recorded at the end of each disc is divided automatically to fit in the full disc capacity.

Tips

- In step 3, by touching [BACKUP] → [Backup starts from the first movie. Previous backup history will be deleted.], you can back up all movies, including movies that have been backed up previously. Your camcorder will keep a backup history of movies only when they are saved with the [BACKUP] function.

Copying still images (DCR-DVD810)

You can copy still images from the internal memory to a “Memory Stick PRO Duo.”

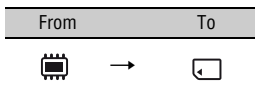

Insert a “Memory Stick PRO Duo” into your camcorder beforehand.

Notes

- Using the AC Adaptor as the power source is recommended to prevent the power from being turned off during operation.

Tips

- To check the copied still images, select [MEMORY STICK] on [PHOTO MEDIA SET] (p. 28).

1 Touch (HOME) → (OTHERS) → [PHOTO COPY].

The [PHOTO COPY] screen appears.

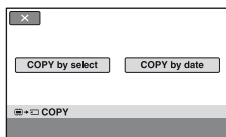

2 Touch [COPY by select].

3 Touch the still image to be copied.

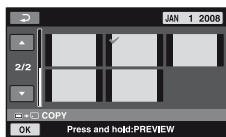

The selected still image is marked with ✓.

Press and hold the still image on the screen to confirm.

Touch  to return to the previous screen.

4 Touch [OK] → [YES].



5 When [Completed.] appears, touch [OK].

To copy all the still images recorded on the same day at one time

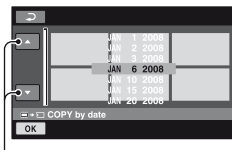
- In step 2, touch [COPY by date].



Previous/Next date

- Touch  /  to select the recording date of the desired still images, then touch [OK].

The still images recorded on the selected date are displayed on the screen.

Touch the still image on the screen to confirm.

Touch  to return to the previous screen.

- Touch [OK] → [YES].
- When [Completed.] appears, touch [OK].

Dividing movies



Select beforehand the media which contains the movie you want to divide (p. 28).

1 Touch (HOME) →
 (OTHERS) → [EDIT].

2 Touch [DIVIDE].

3 Touch the movie that you want to divide.

The selected movie is played back.

4 Touch at the point where you want to divide.

The movie pauses.

Play and pause toggles as you press



Adjusts the dividing point with more precision after the dividing point has been selected with .

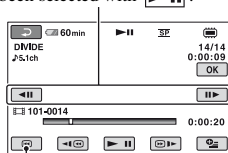

Returns to the beginning of the selected movie.

5 Touch [OK] → [YES].

6 When [Completed.] appears, touch [OK].

Notes

- You cannot restore movies once they are divided.
- Do not remove the battery pack or the AC Adaptor from your camcorder while dividing movies.
- Do not remove the “Memory Stick PRO Duo” while dividing movies in the “Memory Stick PRO Duo.”
- When you select [INT. MEMORY] (DCR-DVD810) or [MEMORY STICK] on [MOVIE MEDIA SET] (p. 28), and the divided original movie is included in a Playlist, the movie in the Playlist will also be divided. When you select [DISC] on [MOVIE MEDIA SET] (p. 28), the movie in a Playlist is not divided.
- A slight difference may occur from the point where you touch and the actual dividing point, as your camcorder selects the dividing point based on about half-second increments.

Tips

- You can divide a movie when viewing it by touching (OPTION).
- The images recorded on your camcorder are called “original.”

Creating the Playlist



A Playlist is a list showing thumbnails of the movies that you have selected. The original scenes are not changed even though you edit or delete the movies in the Playlist.

Select beforehand the media to use to create, play, or edit a Playlist (p. 28).

Tips

- To a Playlist, you can add a maximum of 99 movies on the internal memory (DCR-DVD810) or a “Memory Stick PRO Duo,” or 999 movies on a disc.
- The images recorded on your camcorder are called “original.”

1 Touch (HOME) → (OTHERS) → [PLAYLIST EDIT].

2 Touch [ADD].

3 Touch the movie to be added to the Playlist.

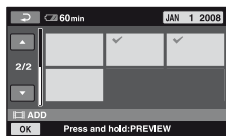

The selected movie is marked with . Press and hold the movie on the screen to confirm. Touch to return to the previous screen.

4 Touch → [YES].

5 When [Completed.] appears, touch .

To add all the movies to the Playlist



- ① In step 2, touch [ADD ALL].
- ② Touch [YES] → [YES].
- ③ When [Completed.] appears, touch .

To add all the movies recorded on the same day at one time



- ① In step 2, touch [ADD by date].

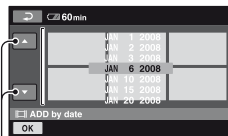

Previous/Next date

- ② Touch to select the recording date of the desired movies, then touch . The movies recorded on the selected date are displayed on the screen. Touch the movie on the screen to confirm. Touch to return to the previous screen.
- ③ Touch → [YES].
- ④ When [Completed.] appears, touch .

Creating the Playlist (Continued)

Notes

- Do not remove the battery pack or the AC Adaptor from your camcorder while adding the movies.
- Do not remove the “Memory Stick PRO Duo” while adding movies in the “Memory Stick PRO Duo.”
- You cannot add still images to a Playlist.

Tips

- You can add a movie when viewing it by touching  (OPTION).
- You can copy the Playlist to a disc as it is, by using the supplied software.

Playing the Playlist



Select beforehand the media to use to create, play or edit a Playlist (p. 28).

1 Touch (HOME) → (VIEW IMAGES) → [PLAYLIST].

The movies in the Playlist screen appear.

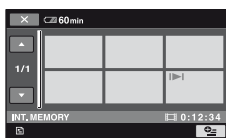





2 Touch the movie from which you want to play back.

The Playlist is played back from the selected movie to the end, then the screen returns to the Playlist screen.

To erase unnecessary movies from the Playlist





- 1 Touch  (HOME) →  (OTHERS) → [PLAYLIST EDIT].
- 2 Touch  [ERASE].
To erase all the movies from the Playlist, touch  [ERASE ALL] → [YES] → [YES]. Then, when [Completed.] appears, touch  [OK].
- 3 Touch the movie to be erased from the Playlist.



The selected movie is marked with .

Press and hold the movie on the screen to confirm.

Touch  to return to the previous screen.

- 4 Touch  [OK] → [YES].
- 5 When [Completed.] appears, touch  [OK].

Tips

- The original movies are not erased even if you erase movies from the Playlist.

To change the order within the Playlist



- 1 Touch **HOME** → **(OTHERS)** → **[PLAYLIST EDIT]**.
- 2 Touch **[MOVE]**.
- 3 Select the movie that you want to move.



The selected movie is marked with ✓.
Press and hold the movie on the screen to confirm.

Touch **[↶]** to return to the previous screen.

- 4 Touch **[OK]**.
- 5 Select the destination with **[←]** / **[→]**.

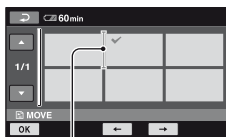

Destination bar

- 6 Touch **[OK]** → **[YES]**.
- 7 When **[Completed.]** appears, touch **[OK]**.

💡 Tips

- When you select multiple movies, the movies are moved following the order appeared in the Playlist.

To divide a movie in the Playlist



- 1 Touch **HOME** → **(OTHERS)** → **[PLAYLIST EDIT]**.
- 2 Touch **[DIVIDE]**.
- 3 Touch the movie that you want to divide.
The selected movie is played back.
- 4 Touch **[▶||]** at the point where you want to divide.
The movie pauses.

Play and pause toggles as you press



Adjusts the dividing point with more precision after the dividing point has been selected with **[▶||]**.

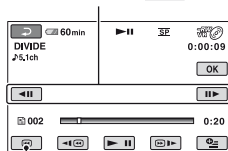

Returns to the beginning of the selected movie.

- 5 Touch **[OK]** → **[YES]**.
- 6 When **[Completed.]** appears, touch **[OK]**.

💡 Notes

- A slight difference may occur from the point where you touch **[▶||]** and the actual dividing point, as your camcorder selects the dividing point based on about half-second increments.

💡 Tips

- The original movies are not divided even if you divide the movie in the Playlist.

Dubbing movies to VCR or DVD/HDD recorders



Connecting a device with the A/V connecting cable

You can dub movies played back on your camcorder to other recording devices, such as VCRs or DVD/HDD recorders. Connect the device in either of the following ways. Connect your camcorder to the wall outlet (wall socket) using the supplied AC Adaptor for this operation (p. 21). Refer also to the instruction manuals supplied with the devices to be connected.

Notes

- Since dubbing is performed via analog data transfer, the image quality may deteriorate.

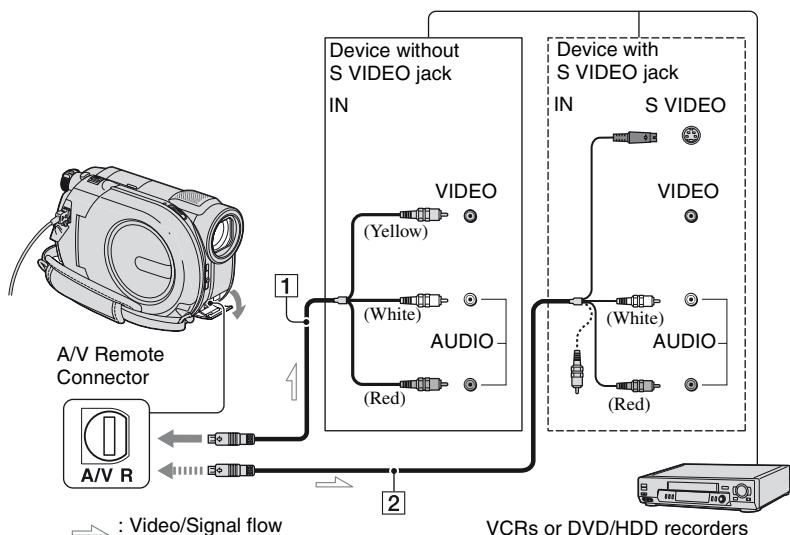

1 A/V connecting cable (supplied)

Connect to the input jack of the other device.

2 A/V connecting cable with S VIDEO (optional)

When connecting to the other device via the S VIDEO jack, by using an A/V connecting cable with S VIDEO (optional), higher quality movies can be produced than with an A/V connecting

cable. Connect the white and red plugs (left/right audio) and the S VIDEO plug (S VIDEO channel) of the A/V connecting cable with S VIDEO (optional). The yellow plug connection is not necessary. Connecting only the S VIDEO plug will not output audio.

Notes

- To hide the screen indicators, such as a counter on the screen of the monitor device connected,

touch **↑**(HOME) → **⚙️**(SETTINGS) → [OUTPUT SETTINGS] → [DISP OUTPUT] → [LCD PANEL] (the default setting) (p. 87).

- To record the date/time and camera settings data, display them on the screen (p. 84).
- When you are connecting your camcorder to a monaural device, connect the yellow plug of the A/V connecting cable to the video input jack, and the red (right channel) or the white (left channel) plug to the audio input jack on the device.

1 Turn on your camcorder.

2 Select the media which contains the movie you want to dub (p. 28).

3 Press **⏏** (VIEW IMAGES).

Set [TV TYPE] according to the display device (p. 48).

4 Insert the recording media in the recording device.

If your recording device has an input selector, set it to the input mode.

5 Connect your camcorder to the recording device (VCR or DVD/HDD recorder) with the A/V connecting cable (supplied) **1** or an A/V connecting cable with S VIDEO (optional) **2**.

Connect your camcorder to the input jacks of the recording device.

6 Start playback on your camcorder, and record it on the recording device.

Refer to the instruction manuals supplied with your recording device for details.

7 When dubbing is finished, stop the recording device, and then your camcorder.

Connecting a device with the USB cable

By connecting a DVD writer, etc. that is capable of movie dubbing via USB connection to your camcorder, you can dub movies without the declination of their image quality.

Connect your camcorder to the wall outlet (wall socket) using the supplied AC Adaptor for this operation (p. 22). Refer also to the instruction manuals supplied with the devices to be connected.

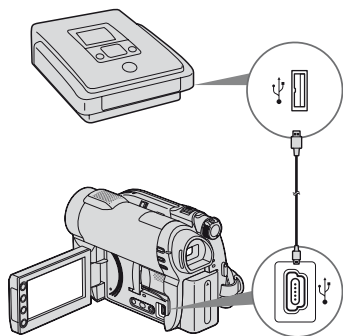

1 Turn on your camcorder.

- 2 Connect the ψ (USB) jack of your camcorder to a DVD writer, etc. using the supplied USB cable (p. 129).

The [USB SELECT] screen appears on the screen.

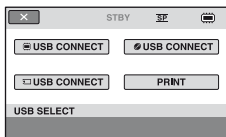

- 3 Touch media which contains the movie to be dubbed.

- 4 Start recording on the connected device.

Refer to the instruction manuals supplied with the connected device for details.

- 5 When dubbing is finished, touch [END] → [YES] and disconnect the USB cable.

Printing still images (PictBridge compliant printer)



You can print out still images using a PictBridge compliant printer, without connecting the camcorder to a computer.

PictBridge

Connect your camcorder to the AC Adaptor to obtain power from the wall outlet (wall socket) (p. 21).

Select beforehand the media which contains the still image you want to print (p. 28).

Also, turn on the printer.

To print still images on a "Memory Stick PRO Duo," insert the "Memory Stick PRO Duo" containing them into your camcorder.

- 1 Turn on your camcorder.

- 2 Connect the ψ (USB) jack of your camcorder to the printer using the supplied USB cable (p. 129).

The [USB SELECT] screen appears on the screen.

- 3 Touch [PRINT].

When connection is complete,  (PictBridge connecting) appears on the screen.

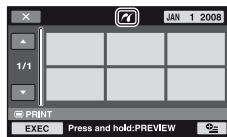

4 Touch the still image to be printed.

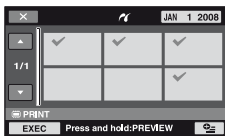

The selected still image is marked with ✓.

Press and hold the still image on the screen to confirm.

Touch [X] to return to the previous screen.

5 Touch [OPTION], set the following options, then touch [OK].

[COPIES]: Set number of copies of a still image to be printed. You can set up to 20 copies.

[DATE/TIME]: Select [DATE], [DAY&TIME], or [OFF] (no date/time printed).

[SIZE]: Select the paper size.

If you do not change the setting, go to step 6.

6 Touch [EXEC] → [YES].

7 When [Completed.] appears, touch [OK].

The still image selection screen appears again.

To finish printing

On the INDEX screen of still images, touch [X].

Notes

- We can guarantee the operation of only models that are PictBridge compatible.
 - Refer also to the instruction manual of the printer to be used.
 - Do not attempt the following operations when [X] is on the screen. The operations may not be performed properly.
 - To operate the POWER switch
 - To press [VIEW IMAGES]
 - To disconnect the USB cable from your camcorder or the printer
 - To remove the “Memory Stick PRO Duo” from your camcorder
 - If the printer stops working, disconnect the USB cable, turn the printer off and on again, and restart the operation from the beginning.
 - You can select only the paper sizes that the printer can print.
 - On some printer models, the top, bottom, right, and left edges of still images may be trimmed. If you print a still image recorded in a 16:9 (wide) ratio, the left and right ends of the image may be trimmed widely.
 - Some printer models may not support the date printing function. Refer to your printer’s instruction manual for details.
 - You may not be able to print the following:
 - still images edited by a computer
 - still images recorded by other devices
 - still images of 4MB or more
 - still images with a pixel size larger than 3,680 × 2,760
- Tips**
- PictBridge is an industry standard established by the Camera & Imaging Products Association (CIPA). You can print still images without using a computer by connecting a printer directly to a digital video camera or digital still camera, regardless of model or manufacturer.
 - You can print a still image when viewing it by touching [OPTION].

(MANAGE MEDIA) category

This category enables you to use the media for various purposes.



 (MANAGE MEDIA) category

Item list

MOVIE MEDIA SET

You can select the media for movies (p. 28).

PHOTO MEDIA SET (DCR-DVD810)

You can select the media for still images (p. 28).

FINALIZE

You can enable discs to be played on other devices by finalizing them (p. 67).

MEDIA INFO

You can display the media information, such as recordable time (p. 71).

MEDIA FORMAT

You can format the media and recover the recordable free space (p. 72).

UNFINALIZE

You can unfinalize a disc and record more images on the disc (p. 74).

DISC SELECT GUIDE

Your camcorder advises you of the right disc for your purpose (p. 75).

REPAIR IMG.DB F.

You can repair the image database file of the internal memory (DCR-DVD810) or "Memory Stick PRO Duo" (p. 76).

Making the disc compatible with playback on other devices (Finalizing)

Finalizing makes the recorded disc compatible for playback with other devices and DVD drives of computers.

Before finalizing, you can select the style of the DVD menu which displays the movie list (p. 69).

Finalizing is required depending on the type of disc.

- DVD-RW/DVD-R/DVD+R DL: Finalizing is required.
- DVD+RW: Finalizing is not required, **except in the following cases:**
 - ① To create a DVD menu
 - ② To play back on a computer DVD drive
 - ③ If the disc has a short total recording time (less than 5 min. in HQ mode, 8 min. in SP mode, or 15 min. in LP mode)

Notes

- Playback compatibility with all devices is not guaranteed.
- No DVD menu is created for DVD-RW (VR mode).

Operation flow

 To play back a disc in other devices for the first time (p.69)

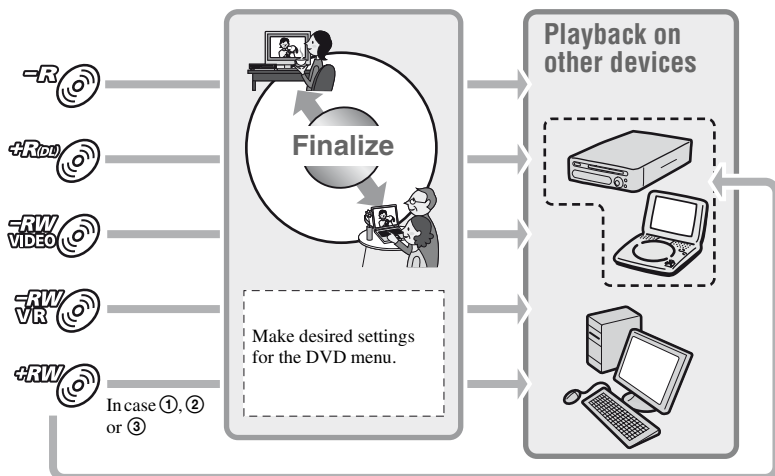

Making the disc compatible with playback on other devices (Finalizing) (Continued)

To add movies to a finalized disc (p.74)

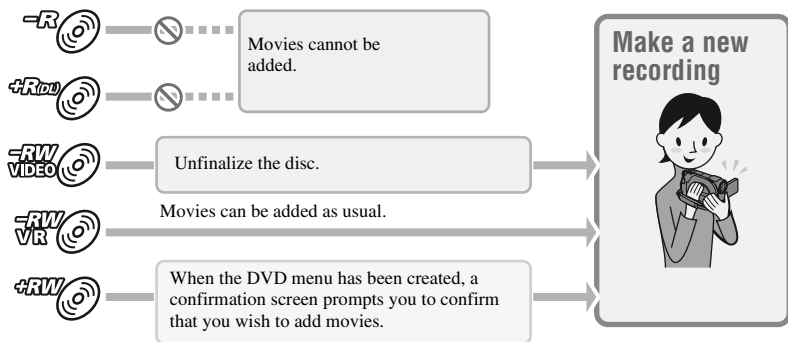

Notes

- During Easy Handycam operation (p. 34), even when you are using a DVD-RW or DVD+RW, you cannot record additional movies onto the disc after finalizing the disc. Cancel Easy Handycam operation.

To play back a disc in other devices after adding movies (p.69)

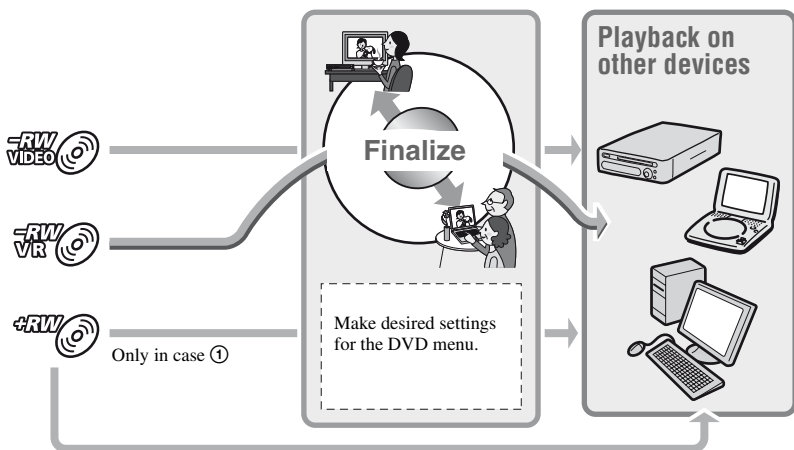

Finalizing a disc

Notes

- It takes from a minute to a maximum of several hours to finalize a disc. The shorter the amount of material recorded on the disc, the longer it takes for finalizing.

1 Place your camcorder in a stable place, and connect the AC Adaptor to the DC IN jack on your camcorder.

2 Turn on your camcorder.

3 Insert the disc to be finalized.

4 Touch **HOME** → **MANAGE MEDIA** → **FINALIZE**.

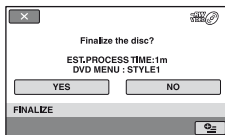

To select a DVD menu style, touch **OPTION** → [DVD MENU] (p. 69).

Go to step **5** if you want to finalize the disc using [STYLE1] (the default setting).

5 Touch **[YES]** → **[YES]**.

Finalizing starts.

6 When finalizing is completed, touch **OK**.

Notes

- When you finalize a double-sided disc, you must finalize each side of the disc individually.
- Do not apply shock or vibration to your camcorder, and do not disconnect the AC Adaptor during finalizing. When you need to disconnect the AC Adaptor, make sure that the power of your camcorder is set to off and disconnect the AC Adaptor after the **MOVIE** (Movie) or **STILL** (Still) lamp goes off. Finalizing restarts when you connect the AC Adaptor and turn on your camcorder again.

Tips

- When you set to create a DVD menu and finalize the disc, the DVD menu appears for a few seconds while finalizing the disc.
- After the disc is finalized, “**VIDEO**” is attached at the bottom of the disc indicator, such as “**VIDEO**” in the case of DVD-RW (VIDEO mode).

To select a DVD menu style

- ① In step **4**, touch **OPTION** → [DVD MENU].
- ② Select the desired style from 4 types of pattern with **←/→**.

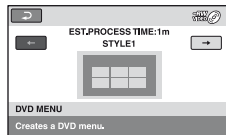

Select **[NO MENU]** if you do not create a DVD menu.

- ③ Touch **OK**.

Playing a disc on other devices

🔒 Notes

- During Easy Handycam operation (p. 34), the DVD menu style is fixed to [STYLE1].
- You cannot create a DVD menu for a DVD-RW (VR mode).

Playing a disc on other devices

Finalizing a disc (p. 67) allows you to view movies recorded by your camcorder on other DVD devices. However, we do not guarantee proper playback on all devices. You can play back DVD+RW on other devices without finalizing the disc.

🔒 Notes

- Do not use an 8 cm CD adaptor with an 8 cm DVD as it may cause a malfunction.
- Make sure that a vertically installed device is placed in a position such as that the disc can be placed horizontally.
- On some devices, some discs may not be played back, movies may freeze for an instant between scenes, or some functions may be disabled.

💡 Tips

- Devices that support subtitles can display the recording date and time where the subtitles normally appear (p. 82). Refer to the instruction manual of your device.
- If you have created a DVD menu (p. 69), you can select the desired scene in the menu.

Playing a disc on a computer

If you finalize the disc (p. 67) that was recorded on your camcorder, you can play back the disc on a computer that DVD playback application is installed.

🔒 Notes

- Even when you use a DVD+RW, you must finalize the disc (p. 67). Otherwise, a malfunction may occur.
- Make sure that the DVD drive of the computer can play an 8 cm DVD.
- Do not use an 8 cm CD adaptor with an 8 cm DVD as it may cause a malfunction.
- The disc may not be played back, or the movies may not be played smoothly on some computers.
- Movies stored on a disc cannot be copied directly onto a computer to be played back or edited.

Checking media information

💡 Tips

- For details on operations and procedures, see the “PMB Guide” on the supplied CD-ROM (p. 97).

The volume label of the disc

The date when the disc was first used is recorded.

<e.g.>

When the disc was first used at 0:00 am on January 1st 2008:

2008_01_01_00H00M_AM

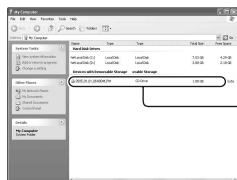

💡 Tips

- Movies on discs are stored in the following folders:
 - DVD-RW (VR mode)
DVD_RTAV folder
 - Other discs and modes
VIDEO_TS folder

You can check the remaining recordable time or space of the media selected on [MOVIE MEDIA SET] (p. 28).

Touch **↑ (HOME)** → **⌂ (MANAGE MEDIA)** → **[MEDIA INFO]**.

You can check other information by touching **→**.

To turn off the display, touch **[X]**.

📌 Notes

- The calculation for the space of the internal memory (DCR-DVD810) and “Memory Stick PRO Duo” is 1MB = 1,048,576 bytes. The fractions less than 1 MB are discarded when the media space is displayed. Therefore, the total amount of available and unavailable space appears slightly smaller.
- Since there is an image database file area, the used space is not displayed as 0 MB even if you perform [MEDIA FORMAT] (p. 72).

💡 Tips

- Only the information for the media selected on [MOVIE MEDIA SET] is displayed. Change the media setting as necessary (p. 28).

Formatting media

Formatting deletes all images and returns the recording media to its original empty state.



To avoid the loss of important images, dub or copy them on other media (p. 55, 62) before performing [MEDIA FORMAT].

Formatting the internal memory (DCR-DVD810) or “Memory Stick PRO Duo”

1 Connect the AC Adaptor to the DC IN jack on your camcorder, then connect the power cord (mains lead) to the wall outlet (wall socket).

2 Turn on your camcorder.

3 When formatting a “Memory Stick PRO Duo,” insert the “Memory Stick PRO Duo” to be formatted into your camcorder.

4 Touch  (HOME) →  (MANAGE MEDIA) → [MEDIA FORMAT] → [INT. MEMORY] (DCR-DVD810) or [MEMORY STICK].

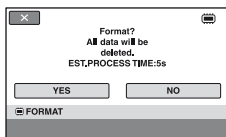

5 Touch [YES] → [YES].

6 When [Completed.] appears, touch .

Notes



- Do not apply shock or vibration to your camcorder, and do not disconnect the AC Adaptor during formatting.
- Even the images protected with another device against accidental deletion are also deleted.
- Do not attempt the following operations when [Executing...] is on the screen:
 - To operate the POWER switch or buttons
 - To remove the “Memory Stick PRO Duo” when formatting the “Memory Stick PRO Duo”

Formatting the disc



A DVD-R/DVD+R DL cannot be formatted. Replace it with a new disc.



If you format a finalized disc

- A DVD-RW (VIDEO mode) returns to the unfinalized state. The disc must be finalized again to view its contents on other devices.
- In the case of a DVD-RW (VR mode)/DVD+RW, formatting deletes all movies on a finalized disc. Even after formatting,  or  will appear on the screen. You do not need to finalize the disc again before playing the disc on other devices.*
- * To create the DVD menu on a DVD+RW, finalize the disc again (p. 69).

1 Connect the AC Adaptor to the DC IN jack on your camcorder, then connect the power cord (mains lead) to the wall outlet (wall socket).

2 Turn on your camcorder.

3 Insert the disc to be formatted into your camcorder.

4 Touch  (HOME) →  (MANAGE MEDIA) → [MEDIA FORMAT] → [DISC].

■ **DVD-RW**

Select the recording format, [VIDEO] or [VR] (p. 13), then touch .

■ **DVD+RW**

Select the aspect ratio of the movie, [16:9 WIDE] or [4:3], then touch .

5 Touch [YES].

6 When [Completed.] appears, touch .

 **Notes**

- You cannot format a disc that has been protected on other devices. Cancel the protection with the original device, and then format it.
-  **Tips**
- When you format a DVD-RW during Easy Handycam operation (p. 34), the recording format is fixed to VIDEO mode.
- Do not apply shock or vibration to your camcorder, and do not disconnect the AC Adaptor during formatting.
 - When you use a double-sided disc, formatting is required on each side. You can format each side in the different recording format.
 - In the case of DVD+RW, you cannot change the movie aspect ratio midway. Format the disc again to change the aspect ratio.

Recording additional movies after finalizing



You can record additional movies on the finalized DVD-RW (VIDEO mode)/DVD+RW discs after the following steps, if the disc has free space.

When using the finalized DVD-RW (VR mode), you can record additional movies on the disc without any additional steps.

Notes

- You cannot record additional movies on the DVD-R/DVD+R DL after finalizing. Use a new disc.

When using a DVD-RW (VIDEO mode) (Unfinalizing)

1 Connect the AC Adaptor to the DC IN jack on your camcorder, then connect the power cord (mains lead) to the wall outlet (wall socket).

2 Turn on your camcorder.

3 Insert the finalized disc into your camcorder.

4 Touch (HOME) → (MANAGE MEDIA) → [UNFINALIZE].

5 Touch [YES] → [YES].

6 When [Completed.] appears, touch .

When using a DVD+RW

If you have created a DVD menu (p. 69) during finalizing, you must perform the following steps prior to recording additional movies.

1 Connect the AC Adaptor to the DC IN jack on your camcorder, then connect the power cord (mains lead) to the wall outlet (wall socket).

2 Turn the POWER switch to turn on the (Movie) lamp.

3 Insert the finalized disc into your camcorder.

A confirmation screen appears to prompt you to confirm that you wish to record additional movies.

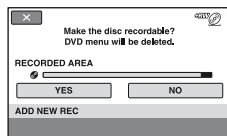

4 Touch [YES] → [YES].



5 When [Completed.] appears, touch .

Finding the right disc (DISC SELECT GUIDE)

🔍 Notes

- Do not apply shock or vibration to your camcorder, and do not disconnect the AC Adaptor during the operation.
- A DVD menu created during finalizing is deleted.
- For a double-sided disc, perform these steps for each side of the disc.

Select the option that is right for you on the screen, then you will be informed of the appropriate disc for your purposes.

1 Touch  (HOME) →  (MANAGE MEDIA) → [DISC SELECT GUIDE].

2 Touch the option that is right for you on the screen.

If you insert the same type of disc as indicated in [DISC SELECT GUIDE], you can format it with your selected settings (p. 72).

Repairing the image database file



This function checks the image database file and the consistency of movies and still images on the internal memory (DCR-DVD810), or movies in the “Memory Stick PRO Duo,” and repairs any inconsistencies found.

Notes

- Do not apply mechanical shock or vibration to the camcorder during this operation.
- Do not disconnect the AC Adaptor or remove the battery pack.
- While the image database file on the “Memory Stick PRO Duo” are being repaired, do not remove the “Memory Stick PRO Duo.”
- Repairing for the internal memory (DCR-DVD810) and a “Memory Stick PRO Duo” are performed separately.

- 1 Touch **HOME** → **MANAGE MEDIA** → **[REPAIR IMG.DB F.]** → **[INT. MEMORY]** (DCR-DVD810) or **[MEMORY STICK]**.

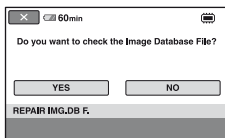

- 2 Touch **[YES]**.

Your camcorder will check the image database file.

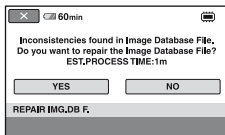

When mismatching is not found, touch **[OK]** to finish the operation.

- 3 Touch **[YES]**.

- 4 When **[Completed.]** appears, touch **[OK]**.

Preventing data on the internal memory from being recovered (DCR-DVD810)

[EMPTY] allows you to write unintelligible data onto the internal memory. In this way, it may become more difficult to recover any original data. When you dispose of or give the camcorder to somebody, it is recommended that you perform [EMPTY].

Notes

- If you perform [EMPTY], all the images are deleted. To avoid the loss of important images, dub or copy them on other media (p. 55, 62) before performing [EMPTY].
- You cannot perform [EMPTY] unless you connect the AC Adaptor to the wall outlet (wall socket).
- Disconnect all cables except the AC Adaptor.
- While performing [EMPTY], do not apply any vibrations or shocks to the camcorder.

1 Connect the AC Adaptor to the DC IN jack on your camcorder, then connect the power cord (mains lead) to the wall outlet (wall socket).

2 Turn on your camcorder.

3 Touch (HOME) → (MANAGE MEDIA) → [MEDIA FORMAT] → [INT. MEMORY].

The screen of formatting the internal memory appears.

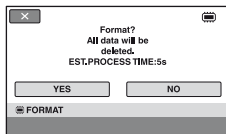

4 Press and hold the (BACK LIGHT) button down (p. 129).

The [EMPTY] screen appears.

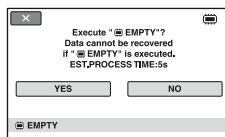

5 Touch [YES] → [YES].

6 When [Completed.] appears, touch .

Notes

- If you stop performing [EMPTY] while [Executing...] is displayed, be sure to complete the operation by performing [EMPTY] again before you use the camcorder the next time.

What you can do with the (SETTINGS) category of the HOME MENU

You can change the recording functions and the operating settings for your convenience.

Using the HOME MENU

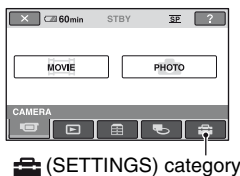
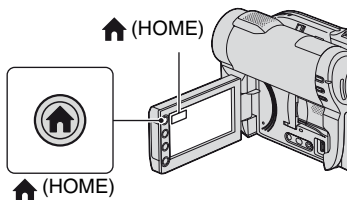

- 1 Turn on your camcorder, then press  (HOME).

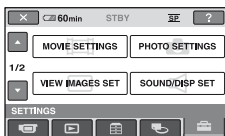

- 2 Touch  (SETTINGS).



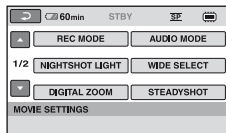

- 3 Touch the desired setup item.

If the item is not on the screen, touch  /  to change the page.



- 4 Touch the desired item.

If the item is not on the screen, touch  /  to change the page.

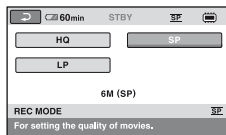

- 5 Change the setting, then touch .

List of the (SETTINGS) category items

MOVIE SETTINGS (p. 80)





Items	Page
REC MODE	80
AUDIO MODE* ¹	80
NIGHTSHOT LIGHT	80
WIDE SELECT	80
DIGITAL ZOOM	81
STEADYSHOT	81
AUTO SLW SHUTTR	81
GUIDEFAME	81
 REMAINING SET	81
SUB-T DATE	82
 INDEX SET* ²	82

PHOTO SETTINGS (p. 82)

Items	Page
 IMAGE SIZE* ²	82
FILE NO.	83
NIGHTSHOT LIGHT	80
GUIDEFAME	81
FLASH MODE* ¹ * ²	83
FLASH LEVEL* ¹	83
REDEYE REDUC* ¹	84

VIEW IMAGES SET (p. 84)

Items	Page
DATA CODE	84
 DISPLAY	85

SOUND/DISP SET*³ (p. 86)

Items	Page
VOLUME* ²	86
BEEP* ²	86
LCD BRIGHT	86
LCD BL LEVEL	86
LCD COLOR	86
VF B. LIGHT	86

OUTPUT SETTINGS (p. 87)

Items	Page
TV TYPE	87
DISP OUTPUT	87

CLOCK/ LANG (p. 88)

Items	Page
CLOCK SET* ²	25
AREA SET	88
DST SET/SUMMERTIME	88
 LANGUAGE SET* ²	88

GENERAL SET (p. 88)

Items	Page
DEMO MODE	88
CALIBRATION	122
A. SHUT OFF	89
QUICK ON STBY	89
REMOTE CTRL* ¹	89

*¹ DCR-DVD710/DVD810

*² You can set these items also during Easy Handycam operation (p. 34).

*³ [SOUND SETTINGS] during Easy Handycam operation (p. 34)

MOVIE SETTINGS

(Items for recording movies)



Touch ①, then ②.

If the item is not on the screen, touch ▲/▼ to change the page.

How to set

🏠 (HOME MENU) → page 78

⊕ (OPTION MENU) → page 90

The default settings are marked with ▶.

REC MODE (Recording mode)

You can select a recording mode to record a movie with the image quality from 3 levels.

HQ (HQ)

Records in high quality mode.
(9M (HQ))

▶ SP (SP)

Records in standard quality mode.
(6M (SP))

LP (LP)

Increases the recording time (Long Play).
(3M (LP))

⚠ Notes

- If you record in LP mode, the quality of scenes may be degraded, or scenes with quick movements may appear with block noise when you play back the movie.

💡 Tips

- See page 14, 33 on the expected recording time of each recording mode.
- You can set the recording mode separately for each media (p. 28).

AUDIO MODE (DCR-DVD710/DVD810)

You can select audio recording format.

▶ 5.1ch SURROUND (5.1ch)

Records 5.1ch surround sound.

2ch STEREO (2ch)

Records stereo sound.

NIGHTSHOT LIGHT

When using either the NightShot plus (p. 41) or the [S. NIGHTSHOT PLS] (p. 95) function to record, you can record clearer images by setting [NIGHTSHOT LIGHT], which emits infrared light (invisible). The default setting is [ON].

⚠ Notes

- Do not cover the infrared port with your fingers or other objects (p. 131).
- Remove the conversion lens (optional).
- The maximum shooting distance using [NIGHTSHOT LIGHT] is about 3 m (10 feet).

WIDE SELECT

When recording images, you can select the aspect ratio according to the TV connected. Refer also to the instruction manuals supplied with your TV.

▶ 16:9 WIDE

Records images to the full screen on a 16:9 (wide) TV screen.

4:3 (4:3)

Records images to the full screen on a 4:3 TV screen.

⚠ Notes

- Set [TV TYPE] correctly according to the TV connected for playback (p. 48).

DIGITAL ZOOM



You can select the maximum zoom level in case you want to zoom greater than optical zoom magnification. Note that the image quality decreases when you use the digital zoom.

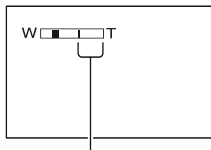

The right side of the bar shows the digital zooming factor. The zooming zone appears when you select the zooming level.

DCR-DVD610

▶ OFF

Up to 40 × zoom is performed optically.

80×

Up to 40 × zoom is performed optically, and after that, up to 80 × zoom is performed digitally.

2000×

Up to 40 × zoom is performed optically, and after that, up to 2,000 × zoom is performed digitally.

DCR-DVD710/DVD810

▶ OFF

Up to 25 × zoom is performed optically.

50×

Up to 25 × zoom is performed optically, and after that, up to 50 × zoom is performed digitally.

2000×

Up to 25 × zoom is performed optically, and after that, up to 2,000 × zoom is performed digitally.

STEADYSHOT



You can compensate for camera shake. Set [STEADYSHOT] to [OFF] (🚫) when using a tripod (optional), then the image becomes natural. The default setting is [ON].

AUTO SLW SHUTTR (Auto slow shutter)



When recording in dark places, the shutter speed is automatically reduced to 1/30 second. The default setting is [ON].

GUIDEFAME



You can display the frame and check that the subject is horizontal or vertical by setting [GUIDEFAME] to [ON]. The frame is not recorded. Press DISP/BATT INFO to make the frame disappear. The default setting is [OFF].

💡 Tips

- Positioning the subject at the cross point of the guide frame makes a balanced composition.

REMAINING SET



▶ ON

Always displays the remaining media capacity indicator.

AUTO

Displays the remaining recording time of movie for about 8 seconds in the following situations.

- When your camcorder recognizes the remaining media capacity when the POWER switch is set to 📽 (Movie).
- When you press DISP/BATT INFO to switch the indicator from off to on when the POWER switch is set to 📽 (Movie).
- When you select the movie recording mode on the HOME MENU.

MOVIE SETTINGS (Continued)

Notes

- When the remaining recordable time for movies is less than 5 minutes, the indicator stays on the screen.

SUB-T DATE



You can display the recording date and time when playing back a disc on a device with a subtitle display function. The default setting is [ON].

Also refer to the instruction manual of the playback device.

Notes

- You cannot set [SUB-T DATE] for the internal memory (DCR-DVD810) or a "Memory Stick PRO Duo."

INDEX SET



The camcorder detects faces automatically during movie recording. The default setting is [ON].

Face icons and their meanings

: This icon appears when the setting is [ON].

: This icon flashes when your camcorder detects a face. The icon stops flashing when the face is recorded in Face Index.

: This icon appears when faces cannot be recorded in Face Index.

To play back scenes using Face Index, see page 45.

Notes

- The number of faces detected in a movie is limited.

PHOTO SETTINGS

(Items for recording still images)



Touch ①, then ②.

If the item is not on the screen, touch / to change the page.

How to set

(HOME MENU) → page 78

(OPTION MENU) → page 90

The default settings are marked with ►.

IMAGE SIZE



DCR-DVD610

► VGA (0.3M) (LVGA 640 × 480)

Records the still images of aspect ratio 4:3 clearly.

0.2M (0.2M 640 × 360)

Records still images clearly in the 16:9 (wide) ratio.

DCR-DVD710/DVD810

► 1.0M (1.0M 1152 × 864)

Records still images of aspect ratio 4:3 clearly.

0.7M (0.7M 1152 × 648)

Records still images clearly in the 16:9 (wide) ratio.



VGA (0.3M) (LVGA 640 × 480)

Records the maximum number of still images of aspect ratio 4:3.

Number of still images recordable on the internal memory (DCR-DVD810)

You can record up to 9,999 still images on the internal memory. The recordable number of still images varies depending on the recording condition.

Number of still images recordable on a “Memory Stick PRO Duo” (approx.)

	1.0M 1152 × 864	VGA (0.3M) 640 × 480
		
512MB	880	2800
1GB	1800	5800
2GB	3700	11500
4GB	7200	23000
8GB	14500	47000

Notes

- Numbers in the table are of when using a “Memory Stick PRO Duo” made by Sony Corporation. The recordable number of still images varies depending on the recording conditions or the type of “Memory Stick.”

Tips

- You can use a “Memory Stick PRO Duo” with a capacity of 256MB or smaller for recording still images.
- The numbers in the table are of the recordable number of still images of the maximum image size that can be recorded with your camcorder. Check the actual recordable number on the screen when you are recording still images (p. 133).

FILE NO. (File number)

► SERIES

Assigns file numbers in sequence, even if the “Memory Stick PRO Duo” is replaced with another one.

RESET

Assigns individual file numbers for each “Memory Stick PRO Duo.”

NIGHTSHOT LIGHT

See page 80.

GUIDEFAME

See page 81.

FLASH MODE (DCR-DVD710/DVD810)

You can set this function when you use an external flash (optional) that is compatible with your camcorder.

► ON (☎)

Flashes every time.

AUTO

Flashes automatically.

Notes

- Remove any dust from the surface of the flash before using it. Flash effect may be impaired if heat discoloration or dust obscures the lamp.
- If you use the flash in bright places such as when shooting a backlit subject, the flash may not be effective.

FLASH LEVEL (DCR-DVD710/DVD810)

You can set this function when you use an external flash (optional) that is compatible with your camcorder.

HIGH(☎+)

Makes the flash level higher.

► NORMAL(☎)

LOW(☎-)

Makes the flash level lower.

REDEYE REDUC (Redeye reduction) (DCR-DVD710/DVD810)

You can set this function when you record still images using an external flash (optional) that is compatible with your camcorder. If you set [FLASH MODE] (p. 83) to [AUTO] or [ON] when [REDEYE REDUC] is set to [ON],  appears on the screen. You can prevent redeye by activating the pre-flash before recording.



Notes



- The redeye reduction may not produce the desired effect due to individual differences and other conditions.

VIEW IMAGES SET

(Items to customize the display)





Touch , then .

If the item is not on the screen, touch /
 to change the page.

How to set

 (HOME MENU) → page 78

 (OPTION MENU) → page 90

The default settings are marked with .

DATA CODE

During playback, your camcorder displays the information (data code) recorded automatically at the time of recording.

OFF

Data code is not displayed.

DATE/TIME

Displays the date and time.

CAMERA DATA

Displays camera setting data.

DATE/TIME

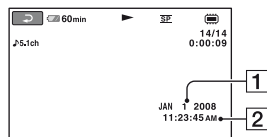

 Date

 Time

CAMERA DATA

Movie

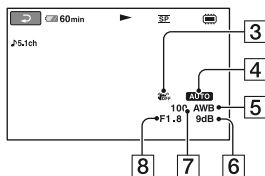

Still image

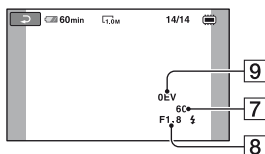

- 3 SteadyShot off
- 4 Brightness
- 5 White balance
- 6 Gain
- 7 Shutter speed
- 8 Aperture value
- 9 Exposure

💡 Tips

-  appears in the following cases.
 - Still images recorded on your camcorder using an optional flash (DCR-DVD710/DVD810)
 - Still images recorded on other cameras using a flash
- The data code is displayed on the TV screen if you connect your camcorder to a TV.
- The indicator toggles through the following sequences as you press DATA CODE on the Remote Commander: [DATE/TIME] → [CAMERA DATA] → [OFF] (no indication) (DCR-DVD710/DVD810).
- Depending on the media condition, bars [--:--:--] appear.

DISPLAY



You can select the number of thumbnails that appear on the VISUAL INDEX or Playlist screen.

Thumbnail  Glossary (p. 135)

▶ ZOOM LINK

Changes the number of thumbnails (6 or 12) with the power zoom lever on your camcorder.*

6IMAGES

Displays thumbnails of 6 images.

12IMAGES

Displays thumbnails of 12 images.

* You can operate with the zoom buttons on the LCD frame or on the Remote Commander (DCR-DVD710/DVD810).

SOUND/DISP SET

(Items to adjust sound and the screen)



Touch ①, then ②.

If the item is not on the screen, touch / to change the page.

How to set

(HOME MENU) → page 78

(OPTION MENU) → page 90

The default settings are marked with .

VOLUME

Touch / to adjust the volume (p. 45).

BEEP

▶ ON

A melody sounds when you start/stop recording, or operate the touch panel.

OFF

Cancels the melody and shutter sound.

LCD BRIGHT

You can adjust the brightness of the LCD screen.

① Adjust the brightness with / .

② Touch .

Tips

- This adjustment does not affect the recorded images in any way.

LCD BL LEVEL (LCD backlight level)

You can adjust the brightness of the LCD screen's backlight.

▶ NORMAL

Standard brightness.

BRIGHT

Brightens the LCD screen.

Notes

- When you connect your camcorder to outside power sources, [BRIGHT] is automatically selected for the setting.
- When you select [BRIGHT], battery life is slightly reduced during recording.
- If you open the LCD panel 180 degrees to face the screen outside and close the LCD panel to the camcorder body, the setting becomes [NORMAL] automatically.

Tips

- This adjustment does not affect the recorded images in any way.

LCD COLOR

You can adjust the color of the LCD screen with / .



Low intensity High intensity

Tips

- This adjustment does not affect the recorded images in any way.

VF B.LIGHT (Viewfinder backlight)

You can adjust the brightness of the viewfinder.

▶ NORMAL

Standard brightness.

BRIGHT

Brightens the viewfinder screen.

OUTPUT SETTINGS

(Items for when connecting other devices)

Notes

- When you connect your camcorder to outside power sources, [BRIGHT] is automatically selected for the setting.
- When you select [BRIGHT], battery life is slightly reduced during recording.

Tips

- This adjustment does not affect the recorded images in any way.

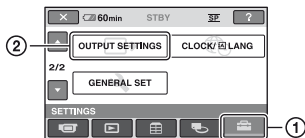

Touch ①, then ②.

If the item is not on the screen, touch ▲/▼ to change the page.

How to set

🏠 (HOME MENU) → page 78

The default settings are marked with ▶.

TV TYPE

See page 48.

DISP OUTPUT

▶ LCD PANEL

Shows displays such as the time code on the LCD screen and in the viewfinder.

V-OUT/PANEL

Shows displays such as the time code on the TV screen, LCD screen, and in the viewfinder.

CLOCK/LANG

(Items to set clock and language)



Touch ①, then ②.

If the item is not on the screen, touch ▲/▼ to change the page.

How to set

🏠 (HOME MENU) → page 78

CLOCK SET

See page 25.

AREA SET

You can adjust a time difference without stopping the clock.

Set your local area using ▲/▼ when using your camcorder in other time zones. Refer to the world time difference on page 115.

DST SET/SUMMERTIME

You can change this setting without stopping the clock.

Set this to [ON] to move the time forward 1 hour.

LANGUAGE SET

You can select the language to be used on the LCD screen.

💡 Tips

- Your camcorder offers [ENG[SIMP]] (simplified English) for when you cannot find your native tongue among the options.

GENERAL SET

(Other setup items)

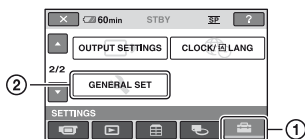

Touch ①, then ②.

If the item is not on the screen, touch ▲/▼ to change the page.

How to set

🏠 (HOME MENU) → page 78

The default settings are marked with ►.

DEMO MODE

You can view the demonstration in about 10 minutes, after you turn the POWER switch to  (Movie). The default setting is [ON].

💡 Tips

- The demonstration will be suspended in the following situations.
 - When you press START/STOP.
 - When you press DUBBING (DCR-DVD810)
 - When you touch the screen during the demonstration (The demonstration starts again after about 10 minutes).
 - When you slide the disc cover OPEN switch.
 - When you move the POWER switch to still image recording.
 - When you press 🏠 (HOME)/▶ (VIEW IMAGES).

CALIBRATION

See page 122.

A.SHUT OFF (Auto shut off)



► 5min

The camcorder is automatically turned off when you do not operate your camcorder for more than approximately 5 minutes.

NEVER

The camcorder is not automatically turned off.

🔌 Notes

- When you connect your camcorder to a wall outlet (wall socket), [A.SHUT OFF] is automatically set to [NEVER].

QUICK ON STBY



You can set the time after which the camcorder turns off automatically in sleep mode. The default setting is [10min].

🔌 Notes

- [A.SHUT OFF] does not work in sleep mode (p. 41).

REMOTE CTRL (Remote control) (DCR-DVD710/DVD810)



You can use the supplied Remote Commander (p. 132). The default setting is [ON].

💡 Tips

- Set to [OFF] to prevent your camcorder from responding to a command sent by another VCR remote control unit.

Activating functions using the OPTION MENU

The OPTION MENU appears just like the pop-up window that appears when you right-click the mouse on a computer. Various functions are displayed.

Using the OPTION MENU

- 1 While using your camcorder, touch  (OPTION) on the screen.

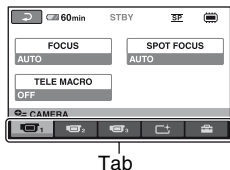
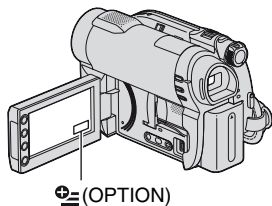

- 2 Touch the desired item.

If you cannot find the desired item, touch another tab to change the page.

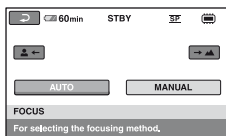





If you cannot find the item anywhere, the function does not work under the current situation.

- 3 Change the setting, then touch .

Notes

- The tabs and items that appear on the screen depend on the recording/playback status of your camcorder at the time.
- Some items appear without a tab.
- The OPTION MENU cannot be used during Easy Handycam operation (p. 34).







Recording items on the OPTION MENU

Items	 *	Page
 tab		
FOCUS	-	92
SPOT FOCUS	-	92
TELE MACRO	-	92
EXPOSURE	-	93
SPOT METER	-	93
SCENE SELECTION	-	93
WHITE BAL.	-	94
COLOR SLOW SHTR	-	95
S. NIGHTSHOT PLS	-	95
 tab		
FADER	-	95
D.EFFECT	-	96
PICT.EFFECT	-	96
 tab		
REC MODE	○	80
BLT-IN ZOOM MIC	-	96
MICREF LEVEL	-	96
 IMAGE SIZE	○	82
SELF-TIMER	-	96
FLASH MODE**	○	83

* Items that are included also in the HOME MENU

** DCR-DVD710/DVD810

Viewing items on the OPTION MENU

Items	 *	Page
 tab		
DELETE**	○	51
DELETE by date**	○	51
DELETE ALL**	○	51
 tab		
DIVIDE	○	58
ERASE**	○	60
ERASE ALL**	○	60
MOVE**	○	61
-- (A tab depends on the situation/No tab)		
 ADD**	○	59
 ADD by date**	○	59
 ADD ALL**	○	59
PRINT	○	64
SLIDE SHOW	-	47
VOLUME	○	86
DATA CODE	○	84
SLIDE SHOW SET	-	47
COPIES	-	64
DATE/TIME	-	64
SIZE	-	64
DVD MENU	-	69

* Items that are included also in the HOME MENU

** These items are also available in the HOME MENU, but with different item names.

Functions set in the OPTION MENU





Items you can set only on the OPTION MENU will be described below.

The default settings are marked with ►.

FOCUS

You can adjust the focus manually. You can select this function also when you want to focus on a certain subject intentionally.



- 1 Touch [MANUAL].
 appears.
- 2 Touch  (focusing on close subjects)/
 (focusing on distant subjects) to sharpen the focus.  appears when the focus cannot be adjusted any closer, and  appears when the focus cannot be adjusted farther away.
- 3 Touch [OK].

To adjust the focus automatically, touch [AUTO] → [OK] in step ①.

Notes

- The minimum possible distance between the camcorder and the subject while maintaining sharp focus is about 1 cm (about 13/32 in.) for wide angle and about 80 cm (about 2 5/8 feet) for telephoto.

Tips

- It is easier to focus on the subject by moving the power zoom lever towards T (telephoto) to adjust the focus, then towards W (wide angle) to adjust the zoom for recording. When you want to record a subject at close range, move the power zoom lever to W (wide angle), then adjust the focus.
- The focal distance information (the distance at which the subject is focused on, for when it is dark and hard to adjust focus) appears for a few seconds in the following cases. (It will not be displayed correctly if you are using a conversion lens (optional).)
 - When the focus mode is switched from automatic to manual.
 - When you set focus manually.

SPOT FOCUS

You can select and adjust the focal point to aim it at a subject not located at the center of the screen.

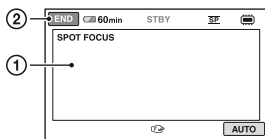

- 1 Touch the subject on the screen.
 appears.
- 2 Touch [END].

To adjust the focus automatically, touch [AUTO] → [END] in step ①.

Notes

- If you set [SPOT FOCUS], [FOCUS] is automatically set to [MANUAL].

TELE MACRO

This is useful to record small subjects, such as flowers or insects. You can blur out backgrounds and the subject stands out clearer.

When you set [TELE MACRO] to [ON] () the zoom (p. 40) moves to the top of the T (telephoto) side automatically and allows recording subjects at a close distance.

- DCR-DVD610
Down to about 43 cm (17 in.)
- DCR-DVD710/DVD810
Down to about 38 cm (15 in.)



To cancel, touch [OFF], or zoom to wide angle (W side).

Notes

- When recording a distant subject, focusing may be difficult and can take some time.

- Adjust the focus manually ([FOCUS], p. 92) when it is hard to focus automatically.

EXPOSURE



You can fix the brightness of an image manually. Adjust the brightness when the subject is too bright or too dark relative to the background.

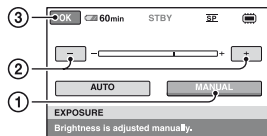

- ① Touch [MANUAL].
←————→ appears.
- ② Adjust the exposure by touching [−] / [+] .
- ③ Touch [OK].

To return the setting to automatic exposure, touch [AUTO] → [OK] in step ①.

SPOT METER (Flexible spot meter)



You can adjust and fix the exposure to the subject, so that it is recorded in suitable brightness even when there is strong contrast between the subject and the background, such as subjects in the spotlight on stage.

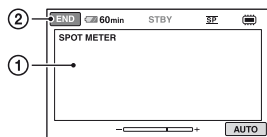

- ① Touch the point where you want to fix and adjust the exposure on the screen.
←————→ appears.
- ② Touch [END].

To return the setting to automatic exposure, touch [AUTO] → [END] in step ①.

Notes

- If you set [SPOT METER], [EXPOSURE] is automatically set to [MANUAL].

SCENE SELECTION



You can record images effectively in various situations with the [SCENE SELECTION] function.

▶ AUTO

Select this to automatically record images effectively without the [SCENE SELECTION] function.

TWILIGHT* (☾)

Select this to take night view without losing the mood.



CANDLE (🕯)

Select this to take scene without losing candle mood.



SUNRISE&SUNSET* (☀)

Select this to reproduce the atmosphere of scenes such as sunsets or sunrises.



FIREWORKS* (💣)

Select this to take spectacular shots of fireworks.



LANDSCAPE* ()

Select this to record distant subjects clearly. This setting also prevents your camcorder from focusing on glass or metal mesh in windows that comes in between the camcorder and the subject.



PORTRAIT ()

Select this to bring out the subject such as people or flowers while creating a soft background.



SPOTLIGHT** ()

Select this to prevent people's faces from appearing excessively white when subjects are lit by strong light.



SPORTS** (Sports lesson) ()

Select this to minimize shake when recording fast moving subjects.



BEACH** ()

Select this to take the vivid blue of the ocean or a lake.



SNOW** ()

Select this to take bright pictures of a white landscape.



* Your camcorder is set to focus only on distant subjects.

** Your camcorder is set not to focus on nearby subjects.

Notes

- The [WHITE BAL.] setting is cleared when you set [SCENE SELECTION].

WHITE BAL. (White balance)



You can adjust the color balance to the brightness of the recording environment.

▶ AUTO

The white balance is adjusted automatically.

OUTDOOR ()

The white balance is adjusted to be appropriate for the following recording conditions:

- Outdoors
- Night views, neon signs and fireworks
- Sunrise or sunset
- Under daylight fluorescent lamps

INDOOR ()

The white balance is adjusted to be appropriate for the following recording conditions:

- Indoors
- At party scenes or studios where the lighting conditions change quickly
- Under video lamps in a studio, or under sodium lamps or incandescent-like color lamps



ONE PUSH ()

The white balance will be adjusted according to the ambient light.

- ① Touch [ONE PUSH].
- ② Frame a white object such as a piece of paper, to fill the screen under the same lighting conditions as you will record the subject.
- ③ Touch [].

 flashes quickly. When the white balance is adjusted and stored in the memory, the indicator stops flashing.

Notes

- Set [WHITE BAL.] to [AUTO] or adjust the color in [ONE PUSH] under white or cool white fluorescent lamps.
- When you select [ONE PUSH], keep framing white object while  is flashing quickly.
-  flashes slowly if [ONE PUSH] could not be set.
- When [ONE PUSH] was selected, if  keeps flashing after touching [OK], set [WHITE BAL.] to [AUTO].
- If you set [WHITE BAL.], [SCENE SELECTION] is automatically set to [AUTO].

Tips

- If you changed the battery pack, or moved your camcorder to or from outdoors when [AUTO] was selected, aim your camcorder at a nearby white object with [AUTO] for about 10 seconds for better color balance adjustment.
- If you changed the [SCENE SELECTION] setting or moved your camcorder to or from outdoors during white balance setting with [ONE PUSH], you need to repeat the [ONE PUSH] operation.

COLOR SLOW SHTR (Color Slow Shutter)



When you set [COLOR SLOW SHTR] to [ON], you can record an image brighter in color even in dark places.

 appears on the screen.

To cancel [COLOR SLOW SHTR], touch [OFF].

Notes

- Adjust the focus manually ([FOCUS], p. 92) when it is hard to focus automatically.
- The shutter speed of your camcorder changes depending on the brightness, which may result in a slowdown of the motion of the image.

S. NIGHTSHOT PLS (Super NightShot plus)



The image will be recorded at a maximum of 16 times the sensitivity of NightShot plus recording if you set [S. NIGHTSHOT PLS]

to [ON] while the NIGHTSHOT PLUS switch (p. 41) is also set to ON.

 appears on the screen.

To return to the normal setting, set [S. NIGHTSHOT PLS] to [OFF].

Notes

- Do not use [S. NIGHTSHOT PLS] in bright places. This may cause a malfunction.
- Do not cover the infrared port with your fingers or other objects (p. 131).
- Remove the conversion lens (optional).
- Adjust the focus manually ([FOCUS], p. 92) when it is hard to focus automatically.
- The shutter speed of your camcorder changes depending on the brightness, which may result in a slowdown of the motion of the image.

FADER



You can record a transition with the following effects adding to the interval between scenes.

- ① Select the desired effect in [STBY] (during fading in) or [REC] (during fading out) mode, then touch [OK].
- ② Press START/STOP.

The fader indicator stops flashing and disappears when the fade is complete.

To cancel the fader before starting the operation, touch [OFF] in step ①. If you press START/STOP, the setting is cleared.



WHITE FADER



BLACK FADER



D.EFFECT (Digital effect)

When you set [OLD MOVIE],  appears and you can add an old movie effect to images.

To cancel [D.EFFECT], touch [OFF].

PICT.EFFECT (Picture effect)

You can add special effects to an image during recording.  appears.

► OFF

Does not use [PICT.EFFECT] setting.

SEPIA

Images appear in sepia.

B&W

Images appear in black and white.

PASTEL

Images appear as a pale pastel drawing.



BLT-IN ZOOM MIC

When you set [BLT-IN ZOOM MIC] to [ON] (), you can record sound with directivity as you move the power zoom lever. The default setting is [OFF].

MICREF LEVEL

You can select the microphone level for recording sound.

Select [LOW] when you want to record exciting and powerful sound in a concert hall, etc.

► NORMAL

Records various surround sounds, converting them into the certain level.

LOW (↑↓)

Records surround sound faithfully. This setting is not suitable for recording conversations.

SELF-TIMER

When you set [SELF-TIMER] to [ON],  appears on the screen.

When you press PHOTO, your camcorder starts counting down, and records a still image after about 10 seconds.

To cancel recording, touch [RESET].

To cancel the self-timer, select [OFF].

Tips

- You can also operate by pressing PHOTO on the Remote Commander (DCR-DVD710/DVD810) (p. 132).

What you can do with Windows computer

When you install the “Picture Motion Browser” on a Windows computer from the supplied CD-ROM, you can enjoy the following operations.

- **Importing images taken with your camcorder to a computer**
- **Viewing imported images on a computer**
- **Creating a DVD**
- **Copying a disc**
→ **Video Disc Copier**

For details on the functions of “Picture Motion Browser,” see “PMB Guide” (p. 99).

■ Using a Macintosh computer

The supplied software “Picture Motion Browser” does not support a Macintosh computer.

On the advanced use of images on your camcorder connected to your Macintosh computer, see the following URL:
<http://guide.d-imaging.sony.co.jp/mac/ms/us/>

Installing the software

■ Environment for using “Picture Motion Browser”

OS: Microsoft Windows 2000 Professional SP4/Windows XP SP2*/Windows Vista*

* 64-bit editions and Starter (Edition) are not supported.

- Standard installation is required.
- Operation is not assured if the above OS has been upgraded or in a multi-boot environment.

CPU: Intel Pentium III 1 GHz or faster

Application: DirectX 9.0c or later (This product is based on DirectX technology. It is necessary to have DirectX installed.)

Sound system: Direct Sound compatible sound card

Memory: 256 MB or more

Hard disk: Disk volume required for installation: Approximately 500 MB (5 GB or more may be necessary when creating a DVD.)

Display: Minimum 1,024 × 768 dots

Others: ♪ USB port (this must be provided as standard), Hi-Speed USB (USB 2.0 compatible is recommended), DVD burner (CD-ROM drive is necessary for installation.)

🔗 Notes

- Your computer must meet hardware requirements other than those described above for each OS.
- Even in a computer environment where the operations are guaranteed, frames may be dropped from movies, resulting in uneven playback. However, imported images and images on discs created subsequently will not be affected.
- Operations are not guaranteed on all the recommended environments. For example, other open or background applications running on currently may limit product performance.
- “Picture Motion Browser” does not support 5.1ch surround sound reproduction. The sound is reproduced in 2ch sound.

What you can do with Windows computer (Continued)

- Depending on your computer, 8 cm media (DVD+R DL, etc.) cannot be used.
- If you use a Notebook PC, connect it to the AC Adaptor as the power source. Otherwise, the software will not work properly due to the power saving function of the PC.
- You can read images recorded on a “Memory Stick PRO Duo” in a Memory Stick slot of a computer. However, in the following cases, do not use the Memory Stick slot of the computer, but connect your camcorder to the computer with the USB cable:
 - The computer is not compatible with a “Memory Stick PRO Duo.”
 - A Memory Stick Duo adaptor is required.
 - A “Memory Stick PRO Duo” cannot be read in the Memory Stick slot.
 - Reading data from the Memory Stick slot is slow.

■ Installation procedure

You need to install the software to your Windows computer **before connecting your camcorder to the computer**. The installation is required only for the first time.

Contents to be installed and procedures may differ depending on your OS.

- ① Confirm that your camcorder is not connected to the computer.
- ② Turn on the computer.

🔌 Notes

- Log on as an Administrator for installation.
 - Close all applications running on the computer before installing the software.
- ③ Place the supplied CD-ROM in the disc drive of your computer.
- The installation screen appears.



If the screen does not appear

- ① Click [Start], then click [My Computer]. (For Windows 2000, double-click [My Computer].)
- ② Double-click [SONYPICTUTIL (E:)] (CD-ROM) (disc drive).
 - * Drive names (such as (E:)) may vary depending on the computer.
- ④ Click [Install].
- ⑤ Select the language for the application to be installed, then click [Next].
- ⑥ As the screen to confirm the connection appears, connect your camcorder to the computer following the steps below.
 - ① Connect the AC Adaptor to a wall outlet (wall socket).
 - ② Turn on your camcorder.
 - ③ Connect the Ψ (USB) jack (p. 129) of your camcorder to the computer using the supplied USB cable.
 - ④ Touch [🔌 USB CONNECT] on the screen of your camcorder.

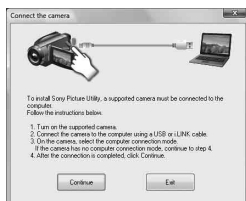

- ⑦ Click [Continue].
- ⑧ Read [License Agreement], select [I accept the terms of the license agreement] if you agree, then click [Next].
- ⑨ Confirm the installation settings, then click [Install].

🔌 Notes

- Even if a screen prompting you to restart your computer appears, you do not need to restart it at this time. Restart your computer after completing the installation.
 - It may take some time for the authentication.
- ⑩ Follow the on-screen instructions to install the software.

One of the following installation screens appears, depending on the computer environment. Check the screen and follow the instructions displayed to install the required software.

- Sonic UDF Reader*
Software required to recognize a DVD-RW (VR mode) disc
 - Windows Media Format 9 Series Runtime (Windows 2000 only)
Software required to create a DVD
 - Microsoft DirectX 9.0c*
Software required to handle movies
- * Windows 2000, Windows XP only

- ⑪ Restart the computer if required to complete the installation.



- ⑫ Remove the CD-ROM from the disc drive of your computer.

■ Operating the Picture Motion Browser

- To start “Picture Motion Browser,” click [Start] - [All Programs] - [Sony Picture Utility] - [PMB - Picture Motion Browser].
- The basic operation of “Picture Motion Browser” is described on “PMB Guide.” To view “PMB Guide,” click [Start] - [All Programs] - [Sony Picture Utility] - [Help] - [PMB Guide].

■ Connecting your camcorder to a computer

To connect your camcorder to a computer, follow the steps below.

- ① Connect the AC Adaptor to your camcorder and a wall outlet (wall socket).
- ② Turn on your camcorder.
- ③ Connect the Ψ (USB) jack (p. 129) of your camcorder to a computer using the supplied USB cable.

The [USB SELECT] screen appears on your camcorder. Touch the item you want to operate on the screen.

💡 Tips

- If the [USB SELECT] screen does not appear, touch \uparrow (HOME) \rightarrow ☰ (OTHERS) \rightarrow [USB CONNECT].

Recommended USB cable connection

To assure the proper functioning of your camcorder, connect your camcorder to a computer as below.

- Connect only the camcorder to the USB port of your computer. Do not connect anything else to other USB ports of a computer.
- When connecting to a computer with a USB keyboard and USB mouse connected as standard equipment, connect the camcorder to another USB port using the USB cable.

⚠ Notes

- Operations are not guaranteed when multiple USB devices are connected to a computer.
- Be sure to connect the USB cable to a USB port. If the USB cable is connected to a computer via a USB keyboard or USB hub, operations are not guaranteed.

To disconnect the USB cable

- ① Click the [Unplug or eject hardware] icon on the task tray on the bottom right of the desk top.



- ② Click [Safely remove USB Mass Storage Device].



- ③ Click [OK] (Windows 2000 only).
- ④ Touch [END] on the screen of your camcorder.
- ⑤ Touch [YES] on the screen of your camcorder.

What you can do with Windows computer (Continued)

- ⑥ Disconnect the USB cable from the camcorder and the computer.

Notes

- Do not disconnect the USB cable while the ACCESS/access lamp is lit.
- Before turning off your camcorder, disconnect the USB cable following the proper procedures described above.
- Disconnect the USB cable using the proper procedures described above. Otherwise, files stored on the media may not be updated correctly. Also, disconnecting the USB cable improperly may cause a malfunction of the media.

Troubleshooting

If you run into any problems using your camcorder, use the following table to troubleshoot the problem. If the problem persists, disconnect the power source and contact your Sony dealer.

• Overall operations/Easy Handycam operation/Remote Commander	101
• Batteries/Power sources	102
• LCD screen/Viewfinder	103
• Media	103
• Recording	104
• Playing back images on your camcorder ...	106
• Playing back a disc on other devices	106
• Playing back a “Memory Stick PRO Duo” on other devices	107
• Editing images on your camcorder	107
• Connecting/Dubbing to other devices	108
• Connecting to a computer	108
• Functions that cannot be used simultaneously	109

Overall operations/Easy Handycam operation/Remote Commander

The power does not turn on.

- Attach a charged battery pack to the camcorder (p. 21).
- Connect the plug of the AC Adaptor to the wall outlet (wall socket) (p. 21).

The camcorder does not operate even when the power is set to on.

- It takes a few seconds for your camcorder to be ready to record after the power is turned on. This is not a malfunction.
- Disconnect the AC Adaptor from the wall outlet (wall socket) or remove the battery pack, then reconnect it after about 1 minute. If the functions still do not work, press the RESET button (p. 129) using a sharp-pointed object. (If you press the RESET button, all settings, including the clock setting, are reset.)
- The temperature of your camcorder is extremely high. Turn off your camcorder and leave it for a while in a cool place.

Buttons do not work.

- During Easy Handycam operation (p. 34), the following buttons/functions are not available.
 - Turning the LCD backlight on and off (pressing and holding the DISP BATT/INFO button for a few seconds) (p. 26)
 -  (BACK LIGHT) button (p. 41)
 - Playback zoom (p. 46)
 - DUBBING button (DCR-DVD810) (p. 55)

The (OPTION) button is not displayed.

- The OPTION MENU cannot be used during Easy Handycam operation (p. 34).

The menu settings have been changed automatically.

- Most menu items automatically return to their default settings during Easy Handycam operation (p. 34).
- The following menu items are fixed during Easy Handycam operation:
 - Movie recording mode: [SP]
 - [DATA CODE]: [DATE/TIME]
 - Recording format for DVD-RW: [VIDEO]
- The following menu items return to the default settings if the POWER switch is set to OFF (CHG) for more than 12 hours:
 - [DVD MENU]
 - [FOCUS]
 - [SPOT FOCUS]
 - [EXPOSURE]
 - [SPOT METER]
 - [SCENE SELECTION]
 - [WHITE BAL.]
 - [COLOR SLOW SHTR]
 - [S. NIGHTSHOT PLS],
 - [BLT-IN ZOOM MIC]
 - [MICREF LEVEL]

Troubleshooting (Continued)

Even if you press EASY, menu settings do not switch to their defaults automatically.

- Following menu settings remain as they were set even during Easy Handycam operation (p. 34).
 - [MOVIE MEDIA SET]
 - [PHOTO MEDIA SET]*
 - [AUDIO MODE]**
 - [WIDE SELECT]
 - [SUB-T DATE]
 - [INDEX SET]
 - [IMAGE SIZE]
 - [FILE NO.]
 - [FLASH MODE]**
 - [DISPLAY]
 - [VOLUME]
 - [BEEP]
 - [TV TYPE]
 - [CLOCK SET]
 - [AREA SET]
 - [DST SET]/[SUMMERTIME]
 - [LANGUAGE SET]
 - [DEMO MODE]

* DCR-DVD810

**DCR-DVD710/DVD810

Your camcorder vibrates.

- Vibration occurs depending on the condition of the disc. This is not a malfunction.

A vibration is felt in your hand or a faint sound is heard during operation.

- This is not a malfunction.

A motor sound is heard in the camcorder when the disc cover is closed without a disc.

- Your camcorder is trying to recognize the disc. This is not a malfunction.

Your camcorder gets warm.

- This is because the power has been turned on for a long time. This is not a malfunction.

Turn off your camcorder and leave it for a while in a cool place.

The supplied Remote Commander does not function (DCR-DVD710/DVD810).

- Set [REMOTE CTRL] to [ON] (p. 89).
- Insert a battery into the battery case with the +/- polarities correctly matching the +/- marks (p. 132).
- Remove any obstructions between the Remote Commander and the remote sensor.
- Point the remote sensor away from strong light sources such as direct sunlight or overhead lighting. Otherwise, the Remote Commander may not function properly.

Another DVD device malfunctions when you use the supplied Remote Commander (DCR-DVD710/DVD810).

- Select a commander mode other than DVD 2 for your DVD device, or cover the sensor of your DVD device with black paper.

Batteries/Power sources

The power abruptly turns off.

- When approximately 5 minutes have elapsed while you do not operate your camcorder, the camcorder is automatically turned off (A.SHUT OFF). Change the setting of [A.SHUT OFF] (p. 89), or turn on the power again, or use the AC Adaptor.
- If the time set with [QUICK ON STBY] (p. 89) has elapsed in sleep mode, your camcorder turns off automatically. Turn on your camcorder again.
- Charge the battery pack (p. 21).

The CHG (charge) lamp does not light while the battery pack is being charged.

- Turn the POWER switch to OFF (CHG) (p. 21).
- Attach the battery pack to the camcorder correctly (p. 21).

- Connect the power cord (mains lead) to the wall outlet (wall socket) properly.
- The battery charge is completed (p. 21).

The CHG (charge) lamp flashes while the battery pack is being charged.

- Attach the battery pack to the camcorder correctly (p. 21). If the problem persists, disconnect the AC Adaptor from the wall outlet (wall socket) and contact your Sony dealer. The battery pack may be damaged.

The remaining battery time indicator does not indicate the correct time.

- The ambient temperature is too high or too low. This is not a malfunction.
- The battery pack has not been charged enough. Fully charge the battery pack again. If the problem persists, replace the battery pack with a new one (p. 21).
- The indicated time may not be correct depending on the environment of use.

The battery pack is quickly discharged.

- The ambient temperature is too high or low. This is not a malfunction.
- The battery pack has not been charged enough. Fully charge the battery pack again. If the problem persists, replace the battery pack with a new one (p. 21).

LCD screen/Viewfinder

Menu items are grayed out.

- You cannot select grayed items in the current recording/playback situation.
- There are some functions you cannot activate simultaneously (p. 109).

The buttons do not appear on the touch panel.

- Touch the LCD screen lightly.
- Press DISP/BATT INFO on your camcorder, or DISPLAY on the Remote Commander (DCR-DVD710/DVD810) (p. 26, 132).

The buttons on the touch panel do not work correctly or do not work at all.

- Adjust the touch panel ([CALIBRATION], p. 122).

The image in the viewfinder is not clear.

- Pull out the viewfinder, then move the viewfinder lens adjustment lever until the image appears clearly (p. 27).

The image in the viewfinder has disappeared.

- Close the LCD panel. No image is displayed in the viewfinder when the LCD panel is open (p. 27).

Media

The disc cannot be removed.

- Make sure the power source (battery pack or AC Adaptor) is connected correctly (p. 21).
- The disc is damaged or is dirty with fingerprints, etc. In this case, it may take up to 10 minutes to remove the disc.
- The temperature of your camcorder is extremely high. Turn off your camcorder and leave it for a while in a cool place.
- You turned off your camcorder during finalizing the disc. Turn on your camcorder and complete finalizing the disc (p. 67).

Images recorded on a disc cannot be deleted.

- The maximum number of images that you can delete on the INDEX screen at one time is 100.
- You cannot delete following movies (p. 51).
 - Movies recorded on DVD-R/DVD+R DL
 - Movies recorded on DVD-RW (VIDEO mode) except the last recorded movie
 - Movies recorded on DVD+RW except the last recorded movie

The indicators of the disc type and the recording format on the LCD screen are grayed out.

- The disc may have been created on another device. You can play back the disc with your camcorder, but you cannot record additional movies on the disc.
 - You inserted a disc that cannot be used with your camcorder.
 - Your camcorder could not recognize the disc.
-

You cannot operate functions using the “Memory Stick PRO Duo.”

- If you use a “Memory Stick PRO Duo” formatted on a computer, format it again on your camcorder (p. 72).
-

You cannot delete images on the “Memory Stick PRO Duo.”

- The maximum number of images that you can delete on the INDEX screen at one time is 100.
 - You cannot delete images from the “Memory Stick PRO Duo” if images are protected by another device.
-

The data file name is not indicated correctly or flashes.

- The file is corrupted.
 - The file format is not supported by your camcorder. Use the supported file format (p. 118).
-

Recording

Refer also to “Media” (p. 103).

Pressing START/STOP or PHOTO does not record images.

- The playback screen is displayed. Set your camcorder to recording standby (p. 39).
 - You cannot record images in sleep mode. Cancel sleep mode by pressing QUICK ON (p. 41).
-

- Your camcorder is recording the image you have just shot on the media.
 - The media has run out of space. Format the media (internal memory (DCR-DVD810)/DVD-RW/DVD+RW/“Memory Stick PRO Duo”) (p. 72). Delete unnecessary images (p. 51), or use a new disc or “Memory Stick PRO Duo.”
 - When you are using one of the following discs after finalizing it, make the disc to be able to record additional movies (p. 74). Or use a new disc.
 - DVD-RW (VIDEO mode)
 - DVD+RW
 - The temperature of your camcorder is extremely high. Turn off your camcorder and leave it for a while in a cool place.
 - Moisture condensation has occurred. Turn off your camcorder and leave it for about 1 hour (p. 121).
 - The number of still images exceeds the capacity of your camcorder (p. 83, 83). Delete unnecessary images (p. 51).
-

You cannot record a still image.

- You cannot record a still image on a disc on your camcorder.
-

The ACCESS/access lamp lights up even when you stop recording.

- Your camcorder is recording the image you have just record on the media.
-

The imaging field looks different.

- The imaging field may look different depending on the condition of your camcorder. This is not a malfunction.
-

The actual recording time for movie is less than the expected recording time of the media.

- Depending on the conditions when recording a fast moving object or so, the time available for recording may shorten.
-

The recording stops.

- The temperature of your camcorder is extremely high. Turn off your camcorder and leave it for a while in a cool place.
- Moisture condensation has occurred. Turn off your camcorder and leave it about 1 hour (p. 121).

There is a time difference between the point where you press START/STOP and the point that movie recording starts/stops.

- On your camcorder, there may be a slight time difference between the point where you press START/STOP and the actual point that movie recording starts/stops. This is not a malfunction.

The movie aspect ratio (16:9/4:3) cannot be changed.

- You cannot change the movie aspect ratio in the following cases.
 - When [DISC] is selected on [MOVIE MEDIA SET], you inserted a DVD+RW, or no disc is inserted.
 - When [MEMORY STICK] is selected on [MOVIE MEDIA SET], no “Memory Stick PRO Duo” is inserted.

The auto focus does not function.

- Set [FOCUS] to [AUTO] (p. 92).
- The recording conditions are not suitable for auto focus. Adjust the focus manually (p. 92).

[STEADYSHOT] does not function.

- Set [STEADYSHOT] to [ON] (p. 81).
- [STEADYSHOT] may not be able to compensate for excessive vibrations.

Tiny spots in white, red, blue, or green appear on the screen.

- The spots appear when you are recording with [S. NIGHTSHOT PLS] or [COLOR SLOW SHTR]. This is not a malfunction.

The color of the image is not correctly displayed.

- Set the NIGHTSHOT PLUS switch to OFF (p. 41).

The screen image is bright, and the subject does not appear on the screen.

- Set the NIGHTSHOT PLUS switch to OFF (p. 41).

The screen image is dark, and the subject does not appear on the screen (DCR-DVD710/DVD810).

- Press and hold DISP/BATT INFO for a few seconds to turn on the backlight (p. 26).

Undesirable flicker occurs.

- This occurs when recording images under a fluorescent lamp, sodium lamp, or mercury lamp. This is not a malfunction.

A vertical band appears when recording candlelight or electric light in the dark.

- This occurs when the contrast between the subject and the background is too high. This is not a malfunction.

A vertical white line appears on an image taken in bright light.

- This phenomenon is called the smear effect. This is not a malfunction.

Black bands appear when you record a TV screen or computer screen.

- Set [STEADYSHOT] to [OFF] (p. 81).

[S. NIGHTSHOT PLS] cannot be operated.

- Set the NIGHTSHOT PLUS switch to ON (p. 41).

[COLOR SLOW SHTR] does not operate correctly.



- [COLOR SLOW SHTR] may not operate correctly in total darkness. Use NightShot plus or [S. NIGHTSHOT PLS].

You cannot adjust [LCD BL LEVEL].

- You cannot adjust [LCD BL LEVEL] when:
 - The LCD panel is closed on your camcorder with the LCD screen facing out.
 - The power is supplied from the AC Adaptor.

Playing back images on your camcorder

You cannot find the images to be played back.

- Select the media to be played back by touching  (HOME) →  (MANAGE MEDIA) → [MOVIE MEDIA SET] or [PHOTO MEDIA SET] (p. 28).

You cannot play back a disc.

- Check out the disc compatibility (p. 13).
- Insert a disc with the recording side facing your camcorder (p. 30).
- The disc that was recorded, formatted, or finalized on other devices may not be played back on your camcorder.
- The temperature of your camcorder is extremely high. Turn off your camcorder and leave it for a while in a cool place.

The playback image is distorted.

- Clean the disc using a soft cloth (p. 118).

Images stored on a “Memory Stick PRO Duo” cannot be played back.

- Images cannot be played back if you have modified files or folders, or have edited the data on a computer. (The file name flashes when viewing the still image.) This is not a malfunction (p. 119).

- Images recorded on other devices may neither be played back, nor displayed in actual size. This is not a malfunction (p. 119).

“?” is indicated on an image in the VISUAL INDEX screen.

- Loading of the data may have failed. It may be indicated correctly when you turn off the power and then turn it on again, or repeat removing and inserting the “Memory Stick PRO Duo” a couple of times.
- You removed the battery pack or the AC Adaptor while the access lamp is flashing. This operation may damage the image data, which will be marked with .
- This may appear on still images recorded on other devices, edited on a computer, etc.

is indicated on an image in the VISUAL INDEX screen.

- Perform [REPAIR IMG.DB F.] (p. 76). If it still appears, delete the image marked with  (p. 51).

No sound or only a quiet sound is heard during playback.

- Turn up the volume (p. 45).
- Sound is not output when the LCD screen is closed. Open the LCD screen.
- When you record sound with [MICREF LEVEL] set to [LOW] (p. 96), the recorded sound may be difficult to hear.

Playing back a disc on other devices

You cannot play back the disc, or the disc is not recognized.

- Clean the disc using a soft cloth (p. 118).
- Finalize the disc (p. 67).
- A disc recorded in VR mode cannot be played back on a device that does not support VR mode. Check the compatibility in the instruction manual of the playback device.

The playback image is distorted.

- Clean the disc using a soft cloth (p. 118).

“?” is indicated on an image in the DVD menu.

- Loading of the data may have failed while finalizing the disc. For the following discs, make the disc capable of additional recording (p. 74), then remake the DVD menu by finalizing the disc again (p. 67). The DVD menu may be displayed correctly.
 - DVD-RW (VIDEO mode)
 - DVD+RW

Playback freezes for an instant between the scenes.

- The image may freeze for an instant between scenes depending on the device being used. This is not a malfunction.
- In the case of a DVD+R DL, the image may freeze for an instant when the recording layer changes. This is not a malfunction.

Playback does not move to the previous scene when you press ◀◀.

- If playback crosses 2 titles made automatically by your camcorder when ◀◀ is pressed, playback may not move to the previous scene. Select the desired scene from the menu screen. Refer to the instruction manual of the playback device for further information.

When you play the disc on a computer or another playback device, the left and right sounds are heard out of balance (DCR-DVD710/DVD810).

- This may happen when sound recorded with 5.1ch surround is converted to 2ch (normal stereo sound) on a computer or another playback device (p. 40). This is not a malfunction.
- If the playback device is a 2ch stereo system, change the audio conversion system

(downmix system). For details, refer to the instruction manuals of the playback device.

- When you create a disc using the supplied “Picture Motion Browser” software, select 2ch for the audio setting.
- Record MOVIES with [AUDIO MODE] set to [2ch STEREO] on your camcorder (p. 80).



Playing back a “Memory Stick PRO Duo” on other devices

You cannot play back the “Memory Stick PRO Duo,” or the “Memory Stick PRO Duo” is not recognized.

- The device may not support a “Memory Stick PRO Duo.”

Editing images on your camcorder

Unable to edit.

- Select a media to be edited by touching  (HOME) →  (MANAGE MEDIA) → [MOVIE MEDIA SET] or [PHOTO MEDIA SET] (p. 28).
- You cannot edit movies recorded on DVD-R/DVD+R DL (p. 13).
- There are no images recorded.
- Unable to edit because of the condition of the image.
- You cannot edit an image protected on another device.
- You cannot dub movies from a disc to the internal memory (DCR-DVD810) or a “Memory Stick PRO Duo.”

Movies cannot be added in the Playlist.

- The media is full.
- To a Playlist, you can add 99 movies on the internal memory (DCR-DVD810) or a “Memory Stick PRO Duo,” or 999 movies on a disc (p. 59). Delete unnecessary images (p. 51).
- You cannot add still images in the Playlist.

Movies cannot be divided.

- A movie that is too short cannot be divided.
- A movie protected on another device cannot be divided.

Images cannot be deleted.

- You cannot delete following movies (p. 51).
 - Movies recorded on DVD-R/DVD+R DL
 - Movies recorded on DVD-RW (VIDEO mode) except the last recorded movie
 - Movies recorded on DVD+RW except the last recorded movie
- In the case of disc, you cannot delete movies during Easy Handycam operation (p. 34).
- Images protected on another device cannot be deleted.

Unable to capture a still image from a movie.

- There is not enough free space on the media for saving still images (p. 53).

Unable to finalize.

- Use the AC Adaptor for finalizing operation. Do not use the battery pack.
- The disc has already been finalized. In the case of following discs, follow the required procedure to record additional movies (p. 74):
 - DVD-RW (VIDEO mode)
 - DVD+RW

Unable to [UNFINALIZE].

- [UNFINALIZE] is not available for the following discs:
 - DVD-RW (VR mode)
 - DVD+RW
 - DVD-R
 - DVD+R DL

You cannot edit or record additional images on a disc using other devices.

- You may not be able to edit or record additional images on a disc recorded on your camcorder using other devices.

Connecting/Dubbing to other devices

You cannot hear the sound on the TV connected to your camcorder.

- This is because only the S VIDEO plug is connected. Make sure that you connect also the red and white plugs of the A/V connecting cable with S VIDEO (optional) (p. 62).

The aspect ratio of the image is not correct on the 4:3 TV connected to your camcorder.

- Set [TV TYPE] depending on your TV (p. 48).

You cannot dub.

- The A/V connecting cable is not connected properly. Make sure that the A/V connecting cable is connected to the proper jack, i.e. to the input jack of another device for dubbing a movie from your camcorder (p. 55).

Connecting to a computer

You cannot install “Picture Motion Browser.”

- Check the computer environment required to install “Picture Motion Browser.”
- Install “Picture Motion Browser” in an orderly manner (p. 98).

“Picture Motion Browser” does not work correctly.

- Finish “Picture Motion Browser” and restart your computer.

Your camcorder is not recognized by the computer.

- Install “Picture Motion Browser” (p. 98).
- Disconnect devices from the USB jack of the computer other than the keyboard, mouse, and your camcorder.
- Disconnect the USB cable from the computer and your camcorder, and restart the computer, then connect the computer and your camcorder again in an orderly manner (p. 99).
- Make sure the media check tool of the computer activates. For details on the media check tool, see “PMB Guide.”

Functions that cannot be used simultaneously

The following list shows examples of unworkable combinations of functions and menu items.

Cannot use	Because of following settings
BACK LIGHT	[SPOT METER], [FIREWORKS], [MANUAL] in [EXPOSURE]
[WIDE SELECT]	[OLD MOVIE]
[AUTO SLW SHUTTR]	[S. NIGHTSHOT PLS], [SCENE SELECTION], [COLOR SLOW SHTR], [D.EFFECT], [FADER]
[SPOT FOCUS]	[SCENE SELECTION]
[TELE MACRO]	[SCENE SELECTION]
[EXPOSURE]	NightShot plus, [S. NIGHTSHOT PLS]
[SPOT METER]	NightShot plus, [S. NIGHTSHOT PLS]

Cannot use	Because of following settings
[SCENE SELECTION]	NightShot plus, [S. NIGHTSHOT PLS], [COLOR SLOW SHTR], [OLD MOVIE], [TELE MACRO], [FADER]
[WHITE BAL.]	NightShot plus, [S. NIGHTSHOT PLS]
[COLOR SLOW SHTR]	NightShot plus, [D.EFFECT], [SCENE SELECTION], [FADER]
[S. NIGHTSHOT PLS]	[D.EFFECT], [FADER]
[FADER]	[D.EFFECT], [S. NIGHTSHOT PLS], [COLOR SLOW SHTR], [CANDLE]/ [FIREWORKS] in [SCENE SELECTION]
[D.EFFECT]	[S. NIGHTSHOT PLS], [COLOR SLOW SHTR], [FADER], [SCENE SELECTION], [PICT.EFFECT]
[PICT.EFFECT]	[OLD MOVIE]
[MICREF LEVEL]	[BLT-IN ZOOM MIC]

Warning indicators and messages

Self-diagnosis display/Warning indicators

If indicators appear on the LCD screen or in the viewfinder, check the following. Some symptoms you can fix by yourself. If the problem persists even after you have tried a couple of times, contact your Sony dealer or local authorized Sony service facility.

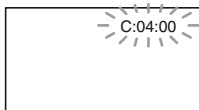

C: (or E:) □□:□□ (Self-diagnosis display)

C:04:□□

- The battery pack is not an “InfoLITHIUM” H series battery pack. Use an “InfoLITHIUM” H series battery pack (p. 119).
- Connect the DC plug of the AC Adaptor to the DC IN jack of your camcorder securely (p. 21).

C:13:□□

- The disc is faulty. Use a compatible disc with your camcorder (p. 13).
- The disc is dirty or has scratches on it. Clean the disc with a cleaning cloth (p. 118).

C:32:□□

- Symptoms that are not described above have occurred. Remove the disc and insert it again, then operate your camcorder again.
- Remove the power source. Reconnect it again and operate your camcorder again.

E:20:□□ / E:31:□□ / E:61:□□ /
E:62:□□ / E:91:□□ / E:94:□□

- A malfunction that you cannot service has occurred. Contact your Sony dealer or local authorized Sony service facility. Inform them of the 5-digit code, which starts from “E.”

101-0001 (Warning indicator pertaining to files)

Slow flashing

- The file is damaged.
- The file is unreadable.

(Warning indicator pertaining to discs)

Slow flashing

- A disc is not inserted.*
- Less than 5 minutes remains for recording movies.
- A disc that cannot be read or written is inserted, such as the single-sided disc inserted inside out.

Fast flashing

- Your camcorder cannot recognize the disc.*
- A finalized disc is inserted into your camcorder during recording standby.
- The disc is fully recorded.*
- The disc recorded in the different TV color system from your camcorder is inserted when  (Movie) is selected.*

(You need to remove the disc)*

Fast flashing

- Your camcorder cannot recognize the disc.
- The disc is fully recorded.
- An error might have occurred with the disc drive in your camcorder.
- A finalized disc is inserted during recording standby (p. 74).

(Battery level warning)

Slow flashing

- The battery pack is nearly used up.
- Depending on the operating environment, or battery conditions,  may flash, even if there are approximately 20 minutes remaining.

(High temperature warning)

Slow flashing

- The temperature of your camcorder is getting higher. Turn off your camcorder and leave it for a while in a cool place.

Fast flashing*

- The temperature of your camcorder is extremely high. Turn off your camcorder and leave it for a while in a cool place.

(Warning indicator pertaining to “Memory Stick PRO Duo”)

Slow flashing

- There is not enough free space for recording. See page 6 for the type of “Memory Stick PRO Duo” you can use in your camcorder.
- No “Memory Stick PRO Duo” is inserted (p. 32).

Fast flashing*

- There is no free space for recording. Delete unnecessary images (p. 51), or format the “Memory Stick PRO Duo” (p. 72) after dubbing/copying images (p. 55, 62, 97).
- The image database file is broken (p. 76).

(Warning indicators pertaining to “Memory Stick PRO Duo” formatting)*

- The “Memory Stick PRO Duo” is damaged.
- The “Memory Stick PRO Duo” is not formatted correctly (p. 72, 118).

(Warning indicator pertaining to incompatible “Memory Stick PRO Duo”)*

- An incompatible “Memory Stick PRO Duo” is inserted (p. 118).

(Warning indicator pertaining to the write-protect of the “Memory Stick PRO Duo”)*

- Access to the “Memory Stick PRO Duo” was restricted on another device.

(Warning indicator pertaining to camera-shake warning)

- The camcorder is unsteady, so camera-shake easily occurs. Hold the camcorder steady with both hands and shoot the image. However, note that the camera-shake warning indicator does not disappear.

(Warning indicator pertaining to still image recording)

- The camcorder cannot record a still image at the moment, because the camcorder is processing the still image just recorded. Wait until the camcorder is ready for recording.

-
- * You hear a melody when the warning indicators appear on the screen (p. 86).

Description of warning messages

If messages appear on the screen, follow the instructions.

■ Media

Internal memory format error.

- The format of the internal memory of your camcorder has been changed from the default format. You may be able to use the internal memory again after formatting it (p. 72). All the data in the internal memory will be deleted.

▲Recording on disc disabled.

- A malfunction has occurred with the disc and the disc cannot be used.

Playback prohibited.

- You are trying to play back an incompatible disc with your camcorder.
- You are trying to play back an image recorded with a copyright protection signal.

▲ Need to unfinalize disc.

- To record on the finalized DVD-RW (VIDEO mode), unfinalize it (p. 74).

▲ Disc error. Remove disc.

- Your camcorder cannot recognize the disc, because the disc is incompatible or has scratches.

▲ Disc error. Unsupported format.

- The disc is recorded in the different format code from your camcorder. Formatting the disc may enable you to use the disc on your camcorder (DVD-RW/DVD+RW only) (p. 72).

Reinsert the Memory Stick.

- Reinsert the “Memory Stick PRO Duo” a few times. If even then the indicator flashes, the “Memory Stick PRO Duo” could be damaged. Try with another “Memory Stick PRO Duo.”

This Memory Stick is not formatted correctly.

- Check the format, then format the “Memory Stick PRO Duo” with your camcorder if necessary (p. 72).

Memory Stick folders are full.

- You cannot create folders exceeding 999MSDCF. You cannot create or delete created folders using your camcorder.
- Format the “Memory Stick PRO Duo” (p. 72), or delete unnecessary folders using your computer.

This Memory Stick may not be able to record or play movies.

- Use the recommended “Memory Stick” (p. 6).

This Memory Stick may not be able to record or play images correctly.

- There may be something wrong with the “Memory Stick PRO Duo.” Insert the “Memory Stick PRO Duo” again.

Do not eject the Memory Stick during writing. Data may be damaged.

- Insert the “Memory Stick PRO Duo” again, and follow the instructions on the screen.

The Image Database File is damaged. Do you want to create a new file?

- The image database file is damaged. When you touch [YES], a new image

database file is created. The old recorded images on the “Memory Stick PRO Duo” cannot be played back (Image files are not damaged). If you perform [REPAIR IMG.DB F.] (p. 76) after creating new image database file, playing back the old recorded images may become possible. If it does not work, copy the image to a computer using the supplied software.

Inconsistencies found in Image Database File. Movies cannot be recorded or played. Do you want to repair the Image Database File?

- The image database file is damaged. Touch [YES] to repair.

■ **PictBridge compliant printer**

Not connected to PictBridge compatible printer.

- Switch off the printer and switch it on again, then disconnect the USB cable and reconnect it.

Cannot print. Check the printer.

- Switch off the printer and switch it on again, then disconnect the USB cable and reconnect it.

■ **Others**

No further selection is possible.

- To a Playlist, you can add 99 movies on the internal memory (DCR-DVD810) or a “Memory Stick PRO Duo,” or 999 movies on a disc (p. 59).
- The maximum number of images that you can select on the INDEX screen at one time is 100 when:
 - deleting images
 - dubbing movies
 - copying still images
 - editing a Playlist
 - printing still images

Data protected.

- The image has been protected with another device. Cancel the protection on the device.

Cannot divide.

- You cannot divide a movie that is extremely short.

Cannot recover data.

- Writing data to the media has failed. Attempts were made to recover the data, but they were unsuccessful.

Please wait.

- This is displayed if the disc removal process takes time. Turn on the camcorder and leave it for about 10 minutes, preventing vibration.

Using your camcorder abroad

Power supply

You can use your camcorder in any countries/regions using the AC Adaptor supplied with your camcorder within the AC 100 V to 240 V, 50/60 Hz range. Use a commercially available AC plug adaptor [a], if necessary, depending on the design of the wall outlet [b].

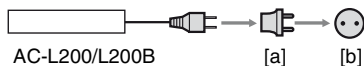

On TV color systems

Your camcorder is an NTSC-system-based camcorder. If you want to view the playback image on a TV, it must be an NTSC-system-based TV with an AUDIO/VIDEO input jack.

System	Used in
NTSC	Bahama Islands, Bolivia, Canada, Central America, Chile, Colombia, Ecuador, Guyana, Jamaica, Japan, Korea, Mexico, Peru, Surinam, Taiwan, the Philippines, the U.S.A., Venezuela, etc.
PAL	Australia, Austria, Belgium, China, Czech Republic, Denmark, Finland, Germany, Holland, Hong Kong, Hungary, Italy, Kuwait, Malaysia, New Zealand, Norway, Poland, Portugal, Singapore, Slovak Republic, Spain, Sweden, Switzerland, Thailand, United Kingdom, etc.
PAL - M	Brazil
PAL - N	Argentina, Paraguay, Uruguay
SECAM	Bulgaria, France, Guiana, Iran, Iraq, Monaco, Russia, Ukraine, etc.

Setting to the local time

You can easily set the clock to the local time by setting a time difference when using your camcorder abroad. Touch **HOME** → **SETTINGS** → **[CLOCK/ LANG]** → **[AREA SET]** and **[DST SET]** or **[SUMMERTIME]** (p. 88).

World time difference

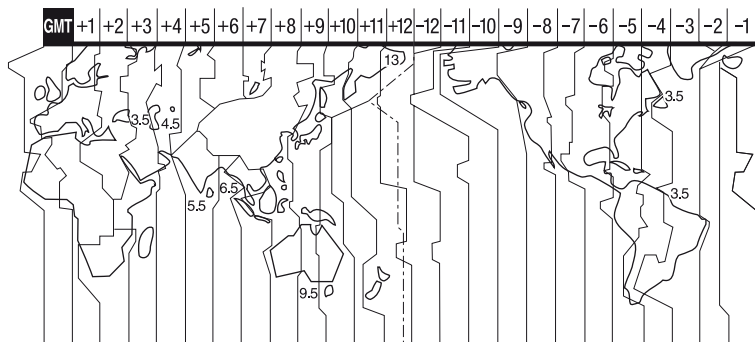

Time-zone differences	Area setting
GMT	Lisbon, London
+01:00	Berlin, Paris
+02:00	Helsinki, Cairo, Istanbul
+03:00	Moscow, Nairobi
+03:30	Tehran
+04:00	Abu Dhabi, Baku
+04:30	Kabul
+05:00	Karachi, Islamabad
+05:30	Calcutta, New Delhi
+06:00	Almaty, Dhaka
+06:30	Rangoon
+07:00	Bangkok, Jakarta
+08:00	Hong Kong, Singapore, Beijing
+09:00	Seoul, Tokyo
+09:30	Adelaide, Darwin
+10:00	Melbourne, Sydney

Time-zone differences	Area setting
+11:00	Solomon Is.
+12:00	Fiji, Wellington
-12:00	Eniwetok, Kwajalein
-11:00	Midway Is., Samoa
-10:00	Hawaii
-09:00	Alaska
-08:00	Los Angeles, Tijuana
-07:00	Denver, Arizona
-06:00	Chicago, Mexico City
-05:00	New York, Bogota
-04:00	Santiago
-03:30	St. John's
-03:00	Brasilia, Montevideo
-02:00	Fernando de Noronha
-01:00	Azores, Cape Verde Is.

File/folder structure on the internal memory (DCR-DVD810) and a “Memory Stick PRO Duo”

The file/folder structure is shown below. You do not usually need to acknowledge the file/folder structure, when recording/playing back images on the camcorder. To enjoy still images or movies by connecting to a computer, see “PMB Guide” on the supplied CD-ROM, then use the supplied application.

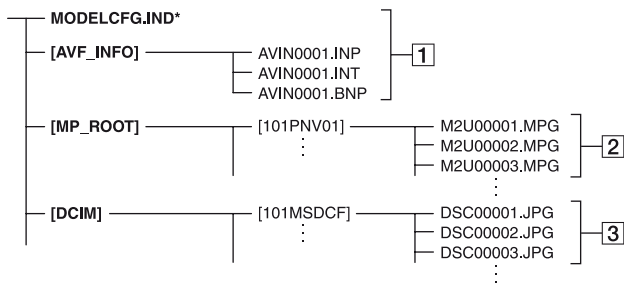

* Internal memory only (DCR-DVD810)

1 Image database files

When you delete the files, you cannot record/play back the images correctly. The files are defaulted as hidden files and not usually displayed.

2 Movie files (MPEG2 files)

The extension of the files is “.MPG”. The maximum size is 2 GB. When the capacity of a file exceeds 2 GB, the file becomes divided.

The file numbers go up automatically. When the capacity of a file number exceeds 9,999, another folder is created to record new movie files.

The folder name goes up: [101PNV01]
→ [102PNV01]

3 Still image files (JPEG files)

The extension of the files is “.JPG”. The file numbers go up automatically. When the capacity of a file number exceeds 9,999, another folder is created to store new image files.

The folder name goes up: [101MSDCF]
→ [102MSDCF]

- You can access the media in the camcorder from a computer connected by the USB cable (p. 99).
- Do not modify the files or folders in the camcorder from a computer. The image files may be destroyed or may not be played back.
- We (Sony) will not be responsible for the results of operating the data on the media in the camcorder from a computer.
- When you delete image files, follow the steps on page 51. Do not delete the image files on the media in the camcorder directly from a computer.
- Do not format the media in the camcorder using a computer. The camcorder may not operate correctly.
- Do not copy the files on a “Memory Stick PRO Duo” in the camcorder from a computer. We (Sony) will not be responsible for the results of this kind of operation.

Maintenance and precautions

About the disc

See page 13 for the details of discs which you can use with your camcorder.

Notes on use

- Hold the disc by its edge while supporting the center hole lightly. Do not touch the recording side (the opposite of the printed side when using a single-sided disc).



- Before shooting, be sure to remove dust and fingerprints from the disc with a soft cloth. Otherwise you may not be able to record or play normally in some situations using that disc.
- When you set the disc in your camcorder, press firmly until it clicks. When the message [C:13:□□] appears on the LCD screen, open the disc cover and set the disc again.
- Do not attach any adhesive material such as a sticker on the surface of a disc. If you do so, the disc may become unbalanced, and this may cause a malfunction of the disc or your camcorder.

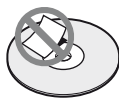

Use of double-sided discs

Double-sided discs allow you to record both sides of a disc.

Recording on the A side

Place the disc in your camcorder with the side with the **A** symbol at the center facing outwards until it clicks.

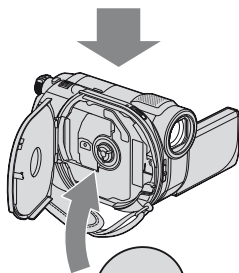
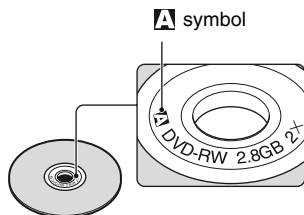

Place the **A** symbol facing outwards. Recording is made on the rear side.

- When using a double-sided disc, take care not to smudge the surface with fingerprints.
- When a double-sided disc is used in your camcorder, recording/playback are performed on that side only. You cannot switch to record on or play back the other side with the disc set to the camcorder. When recording/playback of one side is complete, remove the disc and turn it over to access the other side.
- Perform the following operations on each side of a double-sided disc:
 - Finalizing (p. 67)
 - Formatting (p. 72)
 - Unfinalizing (p. 74)

Maintenance and precautions (Continued)

Care and storage of the discs

- Keep the disc clean, or the image quality of the audio and video output may deteriorate.
- Clean the disc with a soft cloth.
Wipe the disc from the center out. For dirt, clean the disc with a soft cloth slightly moistened in water, then remove the moisture with a soft, dry cloth. Do not use solvents such as benzene, cleaners intended for vinyl LPs or antistatic spray, as they may cause a malfunction to the disc.



- Do not expose the disc to direct sunlight or leave it in a humid place.
- When you carry or store the disc, put it in its case.
- When you want to write letters or marks, etc. on a single-sided disc, write only on the printed side using an oil-based marker with a felt-tip, and do not touch the ink until it dries. Do not heat the disc or use a sharp-pointed tool, such as ball point pen. Do not dry the surface by heating. You cannot write, or mark, on double-sided discs.

About the “Memory Stick”

A “Memory Stick” is a compact, portable IC recording medium with a large data capacity.

You can use only a “Memory Stick Duo,” which is about the half size of a standard “Memory Stick,” with your camcorder. However, we do not guarantee the operation of all types of “Memory Stick Duo” on your camcorder.

Types of “Memory Stick”	Recording/ Playback
“Memory Stick Duo” (with MagicGate)	-
“Memory Stick PRO Duo”	○
“Memory Stick PRO-HG Duo”	○*

- * Your camcorder is not compatible with 8-bit parallel data transfer, but performs 4-bit parallel data transfer, which is used by a “Memory Stick PRO Duo.”
- This product cannot record or play data that uses “MagicGate” technology. “MagicGate” is a copyright protection technology that records and transfers the contents in an encrypted format.
- This product is compatible with “Memory Stick Micro” (“M2”). “M2” is the abbreviation for the “Memory Stick Micro.”
- A “Memory Stick PRO Duo” formatted by a computer (Windows OS/Mac OS) does not have guaranteed compatibility with your camcorder.
- Data read/write speed may vary depending on the combination of the “Memory Stick PRO Duo” and the “Memory Stick PRO Duo” compliant product you use.
- Damaged or lost data may occur in the following cases (the data will not be compensated for):
 - If you eject the “Memory Stick PRO Duo,” or turn off your camcorder while your camcorder is reading or writing image files on the “Memory Stick PRO Duo” (while the access lamp is lit or flashing).
 - If you use the “Memory Stick PRO Duo” near magnets or magnetic fields.
- It is recommended you make a back-up of important data on the hard disk of a computer.
- Be careful not to apply excessive force when writing on a memo area on a “Memory Stick PRO Duo.”
- Do not attach a label or the like on a “Memory Stick PRO Duo” or a Memory Stick Duo adaptor.
- When you carry or store a “Memory Stick PRO Duo,” put it in its case.
- Do not touch, or allow metallic objects to come into contact with the terminals.
- Do not bend, drop or apply strong force to the “Memory Stick PRO Duo.”
- Do not disassemble or modify the “Memory Stick PRO Duo.”
- Do not let the “Memory Stick PRO Duo” get wet.
- Keep the “Memory Stick PRO Duo” out of the reach of small children. They might accidentally swallow it.

- Do not insert anything other than a “Memory Stick PRO Duo” into the Memory Stick Duo slot. Doing so may cause a malfunction.
- Do not use or keep the “Memory Stick PRO Duo” in the following locations:
 - Places subject to extremely high temperature, such as a car parked outside in the summer
 - Places under direct sunlight
 - Places with extremely high humidity or subject to corrosive gases

■ On the Memory Stick Duo adaptor

- When using a “Memory Stick PRO Duo” with a “Memory Stick” compliant device, be sure to insert the “Memory Stick PRO Duo” into a Memory Stick Duo adaptor.
- When inserting a “Memory Stick PRO Duo” into a Memory Stick Duo adaptor, make sure the “Memory Stick PRO Duo” is inserted facing in the correct direction, then insert it all the way in. Note that improper use may cause a malfunction. Also, if you force the “Memory Stick PRO Duo” into the Memory Stick Duo adaptor in the wrong direction, the “Memory Stick PRO Duo” may be damaged.
- Do not insert a Memory Stick Duo adaptor without a “Memory Stick PRO Duo” attached into a “Memory Stick” compliant device. Doing so may result in malfunctions of the device.

■ On a “Memory Stick PRO Duo”

- Up to 8 GB of “Memory Stick PRO Duo” and “Memory Stick PRO-HG Duo” are confirmed to be able to be used with your camcorder.

Notes on using “Memory Stick Micro”

- To use a “Memory Stick Micro” with your camcorder, you need a Duo-sized M2 Adaptor. Insert the “Memory Stick Micro” into the Duo-sized M2 Adaptor, and then insert the adaptor into the Memory Stick Duo slot. If you insert a “Memory Stick Micro” into your camcorder without using a Duo-sized M2 Adaptor, you might not be able to remove it from your camcorder.
- Keep the “Memory Stick Micro” out of the reach of small children. They might accidentally swallow it.

On image data compatibility

- Image data files recorded on a “Memory Stick PRO Duo” by your camcorder conform to the

“Design rule for Camera File system” universal standard established by the JEITA (Japan Electronics and Information Technology Industries Association).

- On your camcorder, you cannot play back still images recorded on other devices (DCR-TRV900 or DSC-D700/D770) that do not conform to the universal standard. (These models are not sold in some regions.)
- If you cannot use a “Memory Stick PRO Duo” that has been used with another device, format it with your camcorder (p. 72). Note that formatting erases all information on the “Memory Stick PRO Duo.”
- You may not be able to play back images with your camcorder:
 - if image data are modified on a computer.
 - if image data are recorded with other devices.

About the “InfoLITHIUM” battery pack

Your camcorder operates only with an “InfoLITHIUM” battery pack (H series). “InfoLITHIUM” H series battery packs have the  mark.

What is an “InfoLITHIUM” battery pack?

An “InfoLITHIUM” battery pack is a lithium-ion battery pack that has functions for communicating information related to operating conditions between your camcorder and an optional AC Adaptor/charger.

The “InfoLITHIUM” battery pack calculates the power consumption according to the operating conditions of your camcorder, and displays the remaining battery time in minutes.

With an AC Adaptor/charger, the remaining battery time and charging time appear.

Maintenance and precautions (Continued)

To charge the battery pack

- Be sure to charge the battery pack before you start using your camcorder.
- We recommend charging the battery pack in an ambient temperature of between 10 °C to 30 °C (50 °F to 86 °F) until the CHG (charge) lamp turns off. If you charge the battery pack outside of this temperature range, you may not be able to charge it efficiently.
- After charging is complete, disconnect the AC Adaptor from the DC IN jack on your camcorder or remove the battery pack.

To use the battery pack effectively

- Battery pack performance decreases when the ambient temperature is 10 °C (50 °F) or below, and the length of time you can use the battery pack becomes shorter. In that case, do one of the followings to use the battery pack for a longer time.
 - Put the battery pack in a pocket to warm it up, and insert it in your camcorder right before you start taking shots.
 - Use a large capacity battery pack: NP-FH70/ NP-FH100 (optional).
- Frequent use of the LCD screen or a frequent playback, fast forward or reverse operation wears out the battery pack faster. We recommend using a large capacity battery pack: NP-FH70/NP-FH100 (optional).
- Be sure to set the POWER switch to OFF (CHG) when not recording or playing back on your camcorder. The battery pack is also consumed when your camcorder is in recording standby or playback pause.
- Have spare battery packs ready for 2 or 3 times the expected recording time, and make trial recordings.
- Do not expose the battery pack to water. The battery pack is not water resistant.



About the remaining battery time indicator

- When the power goes off even though the remaining battery time indicator indicates that the battery pack has enough power to operate, charge the battery pack fully again. Remaining battery time will be indicated correctly. Note, however, that the battery indication will not be restored if it is used in high temperatures for a long time, or if left in a fully charged state, or

when the battery pack is frequently used. Use the remaining battery time indication as a rough guide only.

- The  mark that indicates low battery flashes even if there are still 20 minutes of battery time remaining, depending on the operating conditions or ambient temperature.

About storage of the battery pack

- If the battery pack is not used for a long time, fully charge the battery pack and use it up on your camcorder once a year to maintain proper function. To store the battery pack, remove it from your camcorder and put it in a dry, cool place.
- To discharge the battery pack on your camcorder completely, touch  (HOME) →  (SETTINGS) → [GENERAL SET] → [A.SHUT OFF] → [NEVER] and leave your camcorder in recording standby until the power goes off (p. 89).

About battery life

- Battery capacity decreases over time and through repeated use. If decreased usage time between charges becomes significant, it is probably time to replace it with a new one.
- Each battery's life is governed by storage, operating and environmental conditions.

About handling of your camcorder

On use and care

- Do not use or store the camcorder and accessories in the following locations:
 - Anywhere extremely hot, cold, or humid. Never leave them exposed to temperatures above 60 °C (140 °F), such as under direct sunlight, near heaters or in a car parked in the sun. They may malfunction or become deformed.
 - Near strong magnetic fields or mechanical vibration. The camcorder may malfunction.
 - Near strong radio waves or radiation. The camcorder may not be able to record properly.
 - Near AM receivers and video equipment. Noise may occur.
 - On a sandy beach or anywhere dusty. If sand or dust gets in your camcorder, it may malfunction. Sometimes this malfunction cannot be repaired.
 - Near windows or outdoors, where the LCD screen, the viewfinder, or the lens may be exposed to direct sunlight. This damages the inside of the viewfinder or the LCD screen.
- Operate your camcorder on DC 6.8 V/7.2 V (battery pack) or DC 8.4 V (AC Adaptor).
- For DC or AC operation, use the accessories recommended in these operating instructions.
- Do not let your camcorder get wet, for example, from rain or sea water. If your camcorder gets wet, it may malfunction. Sometimes this malfunction cannot be repaired.
- If any solid object or liquid gets inside the casing, unplug your camcorder and have it checked by a Sony dealer before operating it any further.
- Avoid rough handling, disassembling, modifying, physical shock, or impact such as hammering, dropping or stepping on the product. Be particularly careful of the lens.
- Keep the POWER switch setting to OFF (CHG) when you are not using your camcorder.
- Do not wrap your camcorder with a towel, for example, and operate it. Doing so might cause heat to build up inside.
- When disconnecting the power cord (mains lead), pull it by the plug and not the cord.

- Do not damage the power cord (mains lead) such as by placing anything heavy on it.
- Keep metal contacts clean.
- Keep the Remote Commander and button-type battery out of children's reach. If the battery is accidentally swallowed, consult a doctor immediately (DCR-DVD710/DVD810).
- If the battery electrolytic liquid has leaked:
 - consult your local authorized Sony service facility.
 - wash off any liquid that may have contacted your skin.
 - if any liquid gets in your eyes, wash with plenty of water and consult a doctor.

■ When not using your camcorder for a long time

- Periodically turn it on and let it run such as by playing back or recording images for about 3 minutes.
- Remove a disc from your camcorder.
- Use up the battery pack completely before storing it.

Moisture condensation

If your camcorder is brought directly from a cold place to a warm place, moisture may condense inside your camcorder, on the surface of the disc, or on the pickup lens. This may cause a malfunction to your camcorder.

■ If moisture condensation has occurred

Leave your camcorder for about 1 hour without turning it on.

■ Note on moisture condensation

Moisture may condense when you bring your camcorder from a cold place into a warm place (or vice versa) or when you use your camcorder in a humid place as follows:

- You bring your camcorder from a ski slope into a place warmed up by a heating device.
- You bring your camcorder from an air conditioned car or room into a hot place outside.
- You use your camcorder after a squall or a shower.
- You use your camcorder in a hot and humid place.

Maintenance and precautions (Continued)

■ How to prevent moisture condensation

When you bring your camcorder from a cold place into a warm place, put your camcorder in a plastic bag and seal it tightly. Remove the bag when the air temperature inside the plastic bag has reached the ambient temperature after about 1 hour.

LCD screen



- Do not exert excessive pressure on the LCD screen, as it may cause damage.
- If your camcorder is used in a cold place, a residual image may appear on the LCD screen. This is not a malfunction.
- While using your camcorder, the back of the LCD screen may heat up. This is not a malfunction.

■ To clean the LCD screen

If fingerprints or dust make the LCD screen dirty, it is recommended you use a soft cloth to clean it. When you use the LCD Cleaning Kit (optional), do not apply the cleaning liquid directly to the LCD screen. Use cleaning paper moistened with the liquid.

■ On adjustment of the touch panel (CALIBRATION)

The buttons on the touch panel may not work correctly. If this happens, follow the procedure below. It is recommended that you connect your camcorder to the wall outlet (wall socket) using the supplied AC Adaptor during the operation.

- ① Turn on your camcorder.
- ② Touch  (HOME) →  (SETTINGS) → [GENERAL SET] → [CALIBRATION].

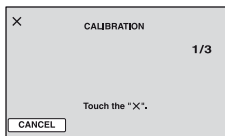

- ③ Touch "x" displayed on the screen 3 times with the corner of a "Memory Stick PRO

Duo" or the like. The position of "x" changes.

Touch [CANCEL] to cancel.

If you did not press the right spot, try the calibration again.

🔌 Notes

- Do not use a sharp-pointed object for calibration. Doing so may damage the LCD screen.
- You cannot calibrate the LCD screen if it is rotated, or closed with the screen facing out.

On handling the casing

- If the casing is soiled, clean the camcorder body with a soft cloth lightly moistened with water, and then wipe the casing with a dry soft cloth.
- Avoid the following to avoid damage to the finish:
 - Using chemicals such as thinner, benzine, alcohol, chemical cloths, repellent, insecticide and sunscreen
 - Handling the camcorder with above substances on your hands
 - Leaving the casing in contact with rubber or vinyl objects for a long period of time

On the pickup lens

- Do not touch the lens inside the disc cover. Keep the disc cover closed except when inserting and removing the disc, to keep dust out.
- When your camcorder does not work because the pickup lens is dirty, clean it with a camera blower (optional). Do not touch the pickup lens directly during cleaning, because this may cause the camcorder to malfunction.

Pickup lens

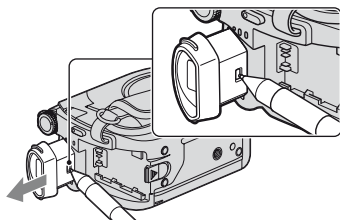
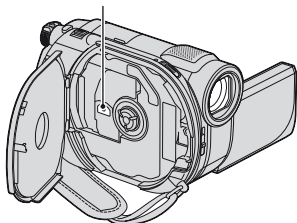

- ③ Remove dust from the eyecup block with a camera blower, etc.

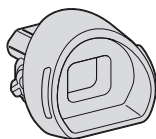

- ④ Press the viewfinder onto the body of the camcorder.
- ⑤ Remove dust from the inside area where the eyecup block was attached with a camera blower, etc.

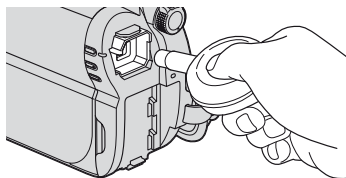

- ⑥ Attach the eyecup block to the viewfinder, pushing it straight on until it clicks.

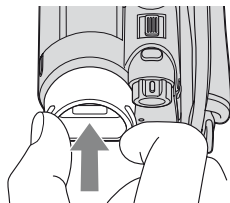

About care and storage of the lens

- Wipe the surface of the lens clean with a soft cloth in the following instances:
 - When there are fingerprints on the lens surface.
 - In hot or humid locations
 - When the lens is exposed to salty air such as at the seaside.
- Store in a well-ventilated location subject to little dirt or dust.
- To prevent mold, periodically clean the lens as described above. It is recommended that you operate your camcorder about once a month to keep it in optimum state for a long time.

Cleaning inside the viewfinder

Remove any dust from inside the viewfinder by following the steps below.

- ① Pull out the viewfinder.
- ② While pushing in the tab on the bottom of the viewfinder with a fine-tipped object such as a ball point pen, pull the eyecup block in the direction of the arrow to remove.

Notes

- The eyecup block is a precision part. Do not disassemble it further.
- Do not touch the lens of the eyecup block.

On charging the pre-installed rechargeable battery

Your camcorder has a pre-installed rechargeable battery to retain the date, time, and other settings even when the POWER switch is set to OFF (CHG). The pre-installed rechargeable battery is always charged while your camcorder is connected to the wall outlet (wall socket) via the AC Adaptor or while the battery pack is attached. The pre-installed rechargeable battery will be fully discharged in about **3 months** if you do not use your camcorder at all. Use your camcorder after charging the pre-installed rechargeable battery. However, even if the pre-installed rechargeable battery is not charged, the camcorder operation will not be affected as long as you are not recording the date.

■ Procedures

Connect your camcorder to a wall outlet (wall socket) using the supplied AC Adaptor, and leave it with the POWER switch set to OFF (CHG) for more than 24 hours.

Specifications

System

Video compression format

MPEG2/JPEG (Still images)

Audio compression format

DCR-DVD610

Dolby Digital 2ch

Dolby Digital Stereo Creator

DCR-DVD710/DVD810

Dolby Digital 2/5.1ch

Dolby Digital 5.1 Creator

Video signal

NTSC color, EIA standards

Internal memory (DCR-DVD810)

8 GB

When measuring media capacity, 1 GB equals 1 billion bytes, a portion of which is used for data management.

Usable discs

8 cm DVD-RW/DVD+RW/DVD-R/
DVD+R DL

Movie recording format

Internal memory (DCR-DVD810)

MPEG2-PS

Disc

DVD-RW: DVD-VIDEO (VIDEO mode),

DVD-Video Recording (VR mode)

DVD+RW: DVD+RW Video

DVD-R/DVD+R DL: DVD-VIDEO

“Memory Stick PRO Duo”

MPEG2-PS

Still image recording format

Exif Ver.2.2*

Viewfinder

Electric viewfinder (color)

Image device

DCR-DVD610

2.25 mm (1/8 type) CCD (Charge Coupled Device)

Gross:

Approx. 680 000 pixels

Effective (Movie, 16:9)

Approx. 410 000 pixels

Effective (Still, 16:9)

Approx. 250 000 pixels

Effective (Still, 4:3)

Approx. 340 000 pixels

DCR-DVD710/DVD810

3 mm (1/6 type) CCD (Charge Coupled Device)

Gross:

Approx. 1 070 000 pixels

Effective (Movie, 16:9)

Approx. 670 000 pixels

Effective (Still, 16:9)

Approx. 750 000 pixels

Effective (Still, 4:3)

Approx. 1 000 000 pixels

Lens

Carl Zeiss Vario-Tessar

DCR-DVD610

Optical: 40×, Digital: 80×, 2 000×

DCR-DVD710/DVD810

Optical: 25×, Digital: 50×, 2 000×

Filter diameter: 30 mm (1 3/16 in.)

Focal length

DCR-DVD610

F 1.8 - 4.1

f = 1.9 - 76 mm (3/32 - 3 in.)

When converted to a 35 mm still camera

For movies:

41 - 1 640 mm (1 5/8 - 64 5/8 in.) (16:9)

For still images:

48 - 1 920 mm (1 15/16 - 75 5/8 in.) (4:3)

DCR-DVD710/DVD810

F 1.8 - 3.2

f = 2.5 - 62.5 mm (1/8 - 2 1/2 in.)

When converted to a 35 mm still camera

For movies:

41 - 1 189 mm (1 5/8 - 46 7/8 in.) (16:9)**

For still images:

36 - 900 mm (1 7/16 - 35 1/2 in.) (4:3)

Color temperature

[AUTO], [ONE PUSH], [INDOOR]

(3 200 K), [OUTDOOR] (5 800 K)

Specifications (Continued)

Minimum illumination

DCR-DVD610

6 lx (lux) (AUTO SLW SHUTTR ON, Shutter speed 1/30 second)

0 lx (lux) (during NightShot plus function)

DCR-DVD710/DVD810

8 lx (lux) (AUTO SLW SHUTTR ON, Shutter speed 1/30 second)

0 lx (lux) (during NightShot plus function)

- * "Exif" is a file format for still images, established by the JEITA (Japan Electronics and Information Technology Industries Association). Files in this format can have additional information such as your camcorder's setting information at the time of recording.

**The focal length figures are actual figures resulting from wide angle pixel readout.

- Manufactured under license from Dolby Laboratories.

Input/Output connectors

A/V Remote Connector

Video/audio output jack

USB jack

mini-B

LCD screen

Picture

6.7 cm (2.7 type, aspect ratio 16:9)

Total number of pixels

123 200 (560 × 220)

General

Power requirements

DC 6.8 V/7.2 V (battery pack)

DC 8.4 V (AC Adaptor)

Average power consumption

Using the LCD screen or the viewfinder with normal brightness

DCR-DVD610

LCD: 2.9 W

Viewfinder: 2.7 W

DCR-DVD710

LCD: 3.3 W

Viewfinder: 2.9 W

DCR-DVD810

LCD: 2.9 W

Viewfinder: 2.5 W

Operating temperature

0 °C to +40 °C (32 °F to 104 °F)

Storage temperature

-20 °C to +60 °C (-4 °F to +140 °F)

Dimensions (Approx.)

55 × 89 × 130 mm (2 1/4 × 3 5/8 × 5 1/8 in.)

(w×h×d) including the projecting parts

55 × 89 × 130 mm (2 1/4 × 3 5/8 × 5 1/8 in.)

(w×h×d) including the projecting parts with

the rechargeable battery pack NP-FH40

attached

Mass (Approx.)

DCR-DVD610

390 g (13 oz) main unit only

440 g (15 oz) including the rechargeable

battery pack NP-FH40 and a disc

DCR-DVD710

400 g (14 oz) main unit only

450 g (15 oz) including the rechargeable

battery pack NP-FH40 and a disc

DCR-DVD810

400 g (14 oz) main unit only

445 g (15 oz) including the rechargeable

battery pack NP-FH40

Supplied accessories

See page 20.

AC Adaptor AC-L200/L200B

Power requirements

AC 100 V - 240 V, 50/60 Hz

Current consumption

0.35 A - 0.18 A

Power consumption

18 W

Output voltage

DC 8.4 V*

Operating temperature

0 °C to +40 °C (32 °F to 104 °F)

Storage temperature

-20 °C to +60 °C (-4 °F to +140 °F)

Dimensions (Approx.)

48 × 29 × 81 mm (1 15/16 × 1 3/16 × 3 1/4 in.)
(w×h×d) excluding the projecting parts

Mass (Approx.)

170 g (6 oz) excluding the power cord (mains lead)

* See at the label of the AC Adaptor for other specifications.

Rechargeable battery pack NP-FH40

Maximum output voltage

DC 8.4 V

Output voltage

DC 7.2 V

Capacity

4.9 Wh (680 mAh)

Type

Li-ion

Design and specifications are subject to change without notice.

On trademarks

- “Handycam” and **HANDYCAM** are registered trademarks of Sony Corporation.
- “Memory Stick,” , “Memory Stick Duo,” “**MEMORY STICK DUO**,” “Memory Stick PRO Duo,” “**MEMORY STICK PRO DUO**,” “Memory Stick PRO-HG Duo,” “**MEMORY STICK PRO-HG DUO**,” “Memory Stick Micro,” “MagicGate,” “**MAGIC GATE**,” “MagicGate Memory Stick” and “MagicGate Memory Stick Duo” are trademarks or registered trademarks of Sony Corporation.
- “InfoLITHIUM” is a trademark of Sony Corporation.
- DVD-RW, DVD+RW, DVD-R, and DVD+R DL logo are trademarks.
- Dolby and the double-D symbol are trademarks of Dolby Laboratories.
- Dolby Digital Stereo Creator and Dolby Digital 5.1 Creator are trademarks of Dolby Laboratories.
- Microsoft, Windows, Windows Media, Windows Vista and DirectX are either registered trademarks or trademarks of Microsoft Corporation in the United States and/or other countries.
- Macintosh and Mac OS are registered trademarks of Apple Inc. in the U.S. and other countries.
- Intel, Intel Core, and Pentium are trademarks or registered trademarks of Intel Corporation or its subsidiaries in the United States and other countries.
- Adobe, the Adobe logo, and Adobe Acrobat are either registered trademarks or trademarks of Adobe Systems Incorporated in the United States and/or other countries.

All other product names mentioned herein may be the trademarks or registered trademarks of their respective companies. Furthermore, TM and © are not mentioned in each case in this manual.

Specifications (Continued)

Notes on the License

ANY USE OF THIS PRODUCT OTHER THAN CONSUMER PERSONAL USE IN ANY MANNER THAT COMPLIES WITH THE MPEG-2 STANDARD FOR ENCODING VIDEO INFORMATION FOR PACKAGED MEDIA IS EXPRESSLY PROHIBITED WITHOUT A LICENSE UNDER APPLICABLE PATENTS IN THE MPEG-2 PATENT PORTFOLIO, WHICH LICENSE IS AVAILABLE FROM MPEG LA, L.L.C., 250 STEELE STREET, SUITE 300, DENVER, COLORADO 80206.

“C Library,” “Expat,” “zlib,” and “libjpeg” software are provided in your camcorder. We provide this software based on license agreements with their owners of copyright. Based on requests by the owners of copyright of these software applications, we have an obligation to inform you of the following. Please read the following sections.

Read “license1.pdf” in the “License” folder on the CD-ROM. You will find licenses (in English) of “C Library,” “Expat,” “zlib,” and “libjpeg” software.

On GNU GPL/LGPL applied software

The software that is eligible for the following GNU General Public License (hereinafter referred to as “GPL”) or GNU Lesser General Public License (hereinafter referred to as “LGPL”) are included in the camcorder.

This informs you that you have a right to have access to, modify, and redistribute source code for these software programs under the conditions of the supplied GPL/LGPL.

Source code is provided on the web. To download, go to the following website and select DCR-DVD810.

<http://www.sony.net/Products/Linux/>

We would prefer you do not contact us about the contents of source code.

Read “license2.pdf” in the “License” folder on the CD-ROM. You will find licenses (in English) of “GPL,” and “LGPL” software.





To view the PDF, Adobe Reader is needed. If it is not installed on your computer, you can download it from the Adobe Systems web page:

<http://www.adobe.com/>

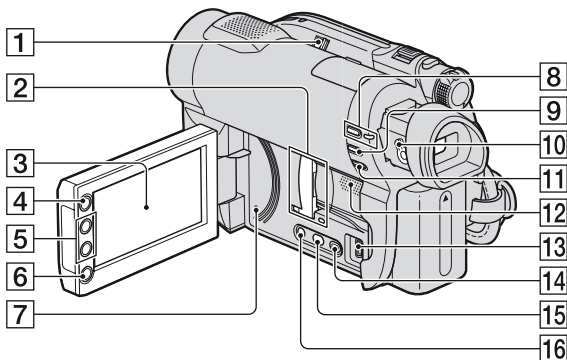
Identifying parts and controls



The numbers in () are reference pages.

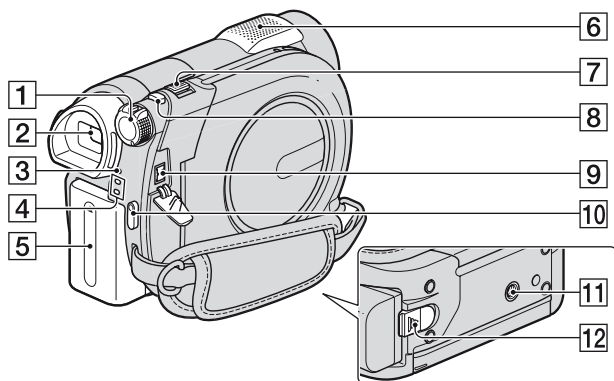

- 1** NIGHTSHOT PLUS switch (41)
- 2** Memory Stick Duo slot/cover and access lamp (32)
The access lamp lights for both the internal memory* and a “Memory Stick PRO Duo.”
- 3** LCD screen/touch panel (17, 26)
- 4**  (HOME) button (18, 78)
- 5** Zoom buttons (40, 46)
- 6** START/STOP button (34, 39)
- 7** RESET button
Initializes all the settings, including the setting of the date and time.
- 8** QUICK ON button and lamp (41)
- 9** EASY button (34)
- 10** Viewfinder lens adjustment lever (27)
- 11**  (BACK LIGHT) button (41)
- 12** Speaker
Playback sounds come out from the speaker. For how to adjust the volume, see page 45.
- 13**  (USB) jack (64)
- 14**  (VIEW IMAGES) button (35, 43)
- 15** DUBBING button* (55)
- 16** DISP/BATT INFO button (22)
* DCR-DVD810

Identifying parts and controls (Continued)



- 1** POWER switch (25)
- 2** Viewfinder (27)
- 3** CHG (charge) lamp (21)
- 4**  (Movie)/ (Still) mode lamps (25)
- 5** Battery pack (21)
- 6** Built-in microphone (40)
An Active Interface Shoe* compatible microphone (optional) will take precedence when connected.
- 7** Power zoom lever (40, 46)
- 8** PHOTO button (34, 39)
- 9** DC IN jack (21)
- 10** START/STOP button (34, 39)
- 11** Tripod receptacle
Attach the tripod (optional: the length of the screw must be less than 5.5 mm (7/32 in.)) to the tripod receptacle using a tripod screw.
- 12** BATT (battery) release lever (22)

* DCR-DVD710/DVD810

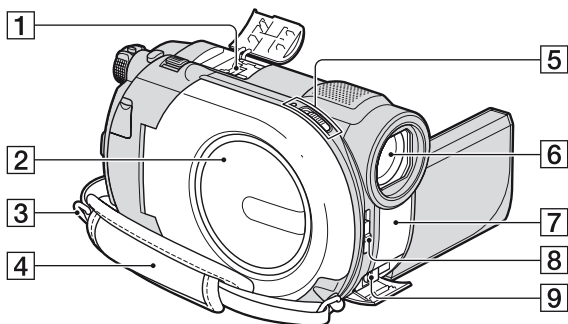

1 Active Interface Shoe Active Interface Shoe *

The Active Interface Shoe supplies power to optional accessories such as a video light, a flash, or a microphone. The accessory can be turned on or off as you operate the POWER switch on your camcorder. Refer to the operating instructions supplied with your accessory for details.

The Active Interface Shoe has a safety device for fixing the installed accessory securely. To connect an accessory, press down and push it to the end, and then tighten the screw. To remove an accessory, loosen the screw, and then press down and pull out the accessory.

- When you are recording movies with an external flash (optional) connected to the accessory shoe, turn off the power of the external flash to prevent charging noise being recorded.
- When an external microphone (optional) is connected, it takes precedence over the built-in microphone (p. 40).

2 Disc cover (30)

3 Hook for a shoulder belt
Attach a shoulder belt (optional).

4 Grip belt (27)

5 Disc cover OPEN switch and ACCESS lamp (30)

6 Lens (Carl Zeiss Lens) (7)

7 Infrared port/Remote sensor*
Point the Remote Commander* (p. 132) towards the remote sensor to operate your camcorder.

8 LENS COVER switch (26)

9 A/V Remote Connector (48, 62)
Connect other optional accessories.

* DCR-DVD710/DVD810

Identifying parts and controls (Continued)

Remote Commander (DCR-DVD710/ DVD810)

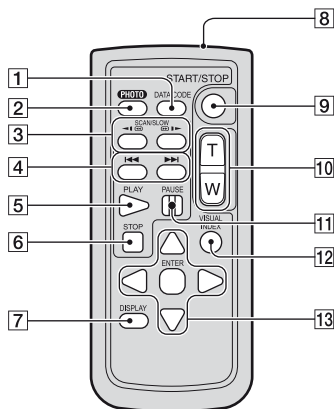

- 1** DATA CODE button (84)
Displays the date and time or camera setting data of the recorded images when you press this during playback.
- 2** PHOTO button (34, 39)
The on-screen image when you press this button will be recorded as a still image.
- 3** SCAN/SLOW buttons (35, 44)
- 4** ◀▶ (Previous/Next) buttons (35, 44)
- 5** PLAY button (35, 44)
- 6** STOP button (35, 44)
- 7** DISPLAY button (22)
- 8** Transmitter
- 9** START/STOP button (34, 39)
- 10** Power zoom buttons (40, 46)
- 11** PAUSE button (35, 44)
- 12** VISUAL INDEX button (35, 43)
Displays a VISUAL INDEX screen when you press this during playback.
- 13** ◀/▶/▲/▼/ENTER buttons
When you press any button on the VISUAL INDEX/Face Index/Film Roll Index/Playlist screen, the orange frame appears on the LCD

screen. Select a desired button or an item with ◀/▶/▲/▼, then press ENTER to enter.

⚠ Notes

- Remove the insulation sheet before using the Remote Commander.

Insulation sheet

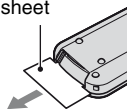

- Point the Remote Commander towards the remote sensor to operate your camcorder (p. 131).
- When no commands have been sent from the Remote Commander in a certain period, the orange frame disappears. When you press any of ◀/▶/▲/▼, or ENTER again, the frame appears at the position where it was displayed last.
- You cannot select some buttons on the LCD screen using ◀/▶/▲/▼.

To change the battery of the Remote Commander

- ① While pressing on the tab, inset your fingernail into the slit to pull out the battery case.
- ② Place a new battery with the + side facing up.
- ③ Insert the battery case back into the Remote Commander until it clicks.

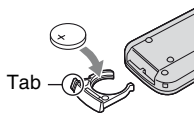

WARNING

Battery may explode if mistreated. Do not recharge, disassemble or dispose of in fire.

- When the lithium battery becomes weak, the operating distance of the Remote Commander may shorten, or the Remote Commander may not function properly. In this case, replace the battery with a Sony CR2025 lithium battery. Use of another battery may present a risk of fire or explosion.

Indicators displayed during recording/playback

Recording movies

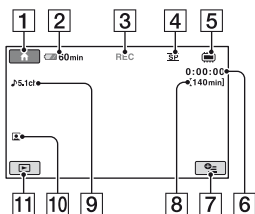

Recording still images

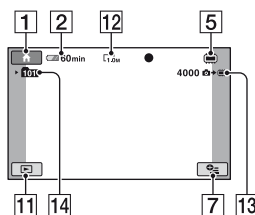

Viewing movies

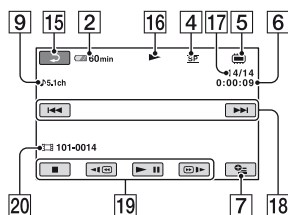

Viewing still images

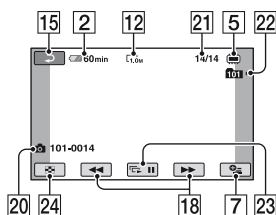

- 1 HOME button (18, 78)
- 2 Remaining battery (approx.) (22)
- 3 Recording status ([STBY] (standby) or [REC] (recording))
- 4 Recording mode (HQ/SP/LP) (80)
- 5 Media type (13)
- 6 Counter (hour/minute/second)
- 7 OPTION button (19, 90)
- 8 Remaining recordable time of movies
- 9 Audio mode (80) (DCR-DVD710/DVD810)
- 10 Face Index set (82)
- 11 VIEW IMAGES button (35, 43)
- 12 Image size (82)
- 13 Remaining recordable number of still images (83, 83)
- 14 Recording folder
When [PHOTO MEDIA SET] is [MEMORY STICK]
- 15 Return button
- 16 Playback mode
- 17 Current movie number/Total number of recorded movies
When [MOVIE MEDIA SET] is [INT. MEMORY] (DCR-DVD810) or [MEMORY STICK]
- 18 Previous/Next button (35, 44)
- 19 Video operation buttons (35, 44)
- 20 Data file name/Scene number
- 21 Current still image number/Total number of recorded still images
- 22 Playback folder
When [PHOTO MEDIA SET] is [MEMORY STICK]
- 23 Slide show button (47)
- 24 VISUAL INDEX button (35, 43)

Indicators displayed during recording/playback (Continued)

Indicators when you made changes

Following indicators appear during recording/playback to indicate the settings of your camcorder.

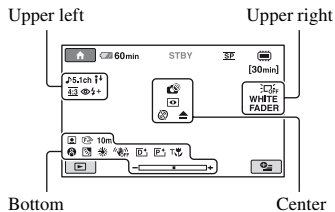

Upper left

Indicator	Meaning
	Audio mode (80)
	MICREF LEVEL low (96)
	WIDE SELECT (80)
	Flash (83, 84)
	Self-timer recording (96)
	BLT-IN ZOOM MIC (96)

Upper right

Indicator	Meaning
	LCD backlight off (26)
	Fader (95)

Center

Indicator	Meaning
	NightShot plus (41)
	Color Slow Shutter (95)
	Super NightShot plus (95)

Indicator	Meaning
	Warning (110)
	PictBridge connecting (64)

Bottom

Indicator	Meaning
	Face Index set (82)
	Manual focus (92)
	SCENE SELECTION (93)
	Backlight (41)
	White balance (94)
	SteadyShot off (81)
	Digital effect (96)
	Picture effect (96)
	Tele macro (92)
	EXPOSURE (93)/ SPOT METER (93)

💡 Tips

- The contents and positions of the indicators illustrated here may differ from the actual indicators on the screen of your camcorder. Some indicators do not appear depending on the model.

Data code during recording

The recording date, time, and camera setting data are recorded automatically on the media. They are not displayed while recording. However, you can check them as [DATA CODE] during playback (p. 84). You can view the recording date and time on another device, etc. ([SUB-T DATE], p. 82).

Glossary

■ 5.1ch surround sound

A system that plays back sound on 6 speakers, 3 at the front (left, right and center) and 2 at the rear (right and left) with an additional low-pass subwoofer counted as a 0.1 channel for frequencies of 120 Hz or lower.

■ Dolby Digital

An audio encoding (compression) system developed by Dolby Laboratories Inc.

■ Dolby Digital 5.1 Creator

Sound compression technology developed by Dolby Laboratories Inc. which compresses audio efficiently while preserving high sound quality. It enables recording of 5.1ch surround sound while using disc space more efficiently. Discs created by Dolby Digital 5.1 Creator can be played back on a device compatible with the disc created on your camcorder.

■ JPEG

JPEG stands for Joint Photographic Experts Group, a still image data compression (data capacity reduction) standard. Your camcorder records still images in JPEG format.

■ MPEG

MPEG stands for Moving Picture Experts Group, the group of standards for the coding (image compression) of video (movie) and audio. There are MPEG1 and MPEG2 formats. Your camcorder records movies in MPEG2 format.

■ Thumbnail

Reduced-size images which enable you to view many images at the same time. [VISUAL INDEX], [🖼️ INDEX], [👤 INDEX], etc. are thumbnail display system.

■ VBR

VBR stands for Variable Bit Rate, the recording format for automatically controlling the bit rate (the volume of recording data in a given time segment) according to the scene being recorded. For fast-moving video, a lot of media space is used to produce a clear image, so the recording time to the media shortens.

■ VIDEO mode

One of the recording formats you can select when using a DVD-RW. VIDEO mode provides excellent compatibility with other DVD devices.

■ VR mode

One of the recording formats you can select when using a DVD-RW. VR mode enables editing (deleting or sequence rearrangement) with your camcorder. Finalizing the disc lets you play it back on a VR mode compatible DVD device.

Index

Numeric

12IMAGES	85
16:9	48
16:9 WIDE	31
4:3	31, 48
5.1ch surround recording.....	40
5.1ch surround sound	40
6IMAGES	85
8cm DVD	13

A

AC Adaptor	21
Additional recording.....	74
AREA SET	88
Aspect ratio.....	48
AUDIO MODE	80
AUTO SLW SHUTTR (Auto slow shutter)	81, 109
A.SHUT OFF (Auto shut off)	89
A/V connecting cable	48, 62

B

BACK LIGHT	41, 109
Battery	21, 132
Battery Info.....	22
BEACH	94
BEEP	86
BLACK FADER	95
BLT-IN ZOOM MIC.....	96
Button-type lithium battery	132
B&W	96

C

CALIBRATION	122
CAMERA DATA	84
CANDLE	93
CD-ROM	97
Charging time	22
CLOCK SET	25

CLOCK/LANG.....	88
COLOR SLOW SHTR (Color Slow Shutter)	95, 109
Computer	97
Connecting	
Printer	64
TV	48
VCR or DVD/HDD recorders	62
Copying still images	56

D

DATA CODE	84
Date Index	46
DATE/TIME.....	26, 84, 134
DC IN jack	21
DC plug.....	21
DELETE	
Movies	51
Still images	52
DEMO MODE.....	88
DIGITAL ZOOM	81
Disc	30
DISC SELECT GUIDE	75
DISP OUTPUT	87
DISPLAY.....	85
DIVIDE	
Original	58
Playlist	61
Dolby Digital 5.1 Creator ..	135
Double-sided disc	117
DST SET	88
Dubbing movies	55, 62
DVD drive.....	70
DVD menu	69
DVD-R.....	13
DVD-RW	13
DVD+R DL.....	13
DVD+RW	13
D.EFFECT (Digital effect)	96, 109

E

Easy Handycam operation....	34
Editing	50
EXPOSURE	93, 109

F

Face Index	45, 82
FADER	95, 109
FILE NO. (File number).....	83
Film Roll Index	45
Finalize	67, 108
FIREWORKS.....	93
FLASH LEVEL.....	83
FLASH MODE	83
FOCUS	92, 105
FORMAT	
Disc	72
Internal memory	72
“Memory Stick PRO Duo”	72

G

GENERAL SET	88
Grip belt.....	27
GUIDEFAME.....	81

H

HOME MENU	17, 78
CLOCK/LANG.....	88
GENERAL SET.....	88
MOVIE SETTINGS.....	80
OUTPUT SETTINGS... ..	87
PHOTO SETTINGS	82
SOUND/DISP SET	86
VIEW IMAGES SET....	84
HQ.....	80

I

ID-1/ID-2.....	49
IMAGE SIZE	82

INDEX SET (Face Index set)	82
Indicators	134
INDOOR	94
InfoLITHIUM	119
Install (software)	97
Insulation sheet	132

J

JPEG	135
------	-----

L

LANDSCAPE	94
LANGUAGE SET	88
LAST SCENE DEL (delete)	52
LCD backlight	27
LCD BL LEVEL (LCD back light level)	86, 106
LCD BRIGHT	86
LCD COLOR	86
LCD panel	26
Lens cover	26
LP	80

M

Maintenance	117
MANAGE MEDIA category	66
"Memory Stick"	6, 118
"Memory Stick PRO Duo"	6, 32, 118
MICREF LEVEL	96, 109
Mirror mode	41
Moisture condensation	121
MOVIE DUB	55
MOVIE SETTINGS	80
Movies	34, 39
MPEG	135

N

NIGHTSHOT LIGHT	80
-----------------	----

NightShot plus	41
NTSC	114
Number of still images recordable	83

O

OLD MOVIE	96
ONE PUSH	94
OPTION MENU	90
Original	
DELETE	51
DIVIDE	58
OTHERS category	50
OUTDOOR	94
OUTPUT SETTINGS	87

P

PAL	114
PASTEL	96
PHOTO COPY	56
PHOTO SETTINGS	82
PictBridge	64
PICT.EFFECT (Picture effect)	96, 109
Playback	35, 43
Playback zoom	46
Playing time	23
Playlist	
Creating	59
Divide	61
Erase	60
Move	61
Playback	60
PORTRAIT	94
Power cord (mains lead)	21
Precautions	117
Preparation	21
Print	64
Protect	113

Q

QUICK ON	41
QUICK ON STBY	89

R

REC MODE (Recording mode)	80
Recording	34, 38
Recording format	13
Recording time	14, 22, 33
REDEYE REDUC	84
Remaining battery	22
REMAINING SET (Remaining media display setting)	81
Remote Commander	102, 132
REMOTE CTRL	89
REPAIR IMG.DB F.	76

S

S video cable	48, 62
SCENE SELECTION	93, 109
Self-diagnosis display	110
SELF-TIMER	96
SEPIA	96
SETTINGS category	78
Slide show	47
SNOW	94
SOUND SETTINGS	79
SOUND/DISP SET	86
SP	80
Specifications	125
SPORTS (Sports lesson)	94
SPOT FOCUS	92, 109
SPOT METER (Flexible spot meter)	93, 109
SPOTLIGHT	94
STEADYSHOT	81
Still Images	34, 39
SUB-T DATE	82
SUMMERTIME	88

Index (Continued)

SUNRISE&SUNSET93
S.NIGHTSHOT PLS (Super
NightShot plus).....95, 109

T

TELE MACRO.....92, 109
Tripod 130
TV color system 114
TV TYPE.....48, 87
TWILIGHT93

U

UNFINALIZE74, 108
USB 2.097
USB cable.....64, 98
Using abroad..... 114

V

VBR.....14
VF B.LIGHT (Viewfinder
backlight).....86
VIDEO mode.....13
VIEW IMAGES SET84
VISUAL INDEX35, 43
VOLUME.....45, 86
VR mode.....13

W

Warning indicators 110
Warning messages 112
WHITE BAL. (White balance)
.....94, 109
WHITE FADER95
WIDE SELECT80, 109
Windows.....97
World time difference 115

Z

Zoom40
ZOOM LINK.....85

Paso 1: Comprobación de los componentes incluidos

Asegúrese de que dispone de los siguientes componentes incluidos con su videocámara. El número entre paréntesis indica el número de componentes incluidos de cada artículo.

Adaptador de ca (1)

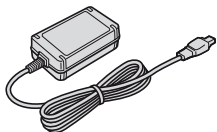

Cable de alimentación (1)



Cable de conexión de A/V (1)



Cable USB (1)

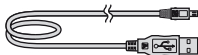

Control remoto inalámbrico (DCR-DVD710/DVD810) (1)



La pila de litio tipo botón ya viene instalada.

Batería recargable NP-FH40 (1)

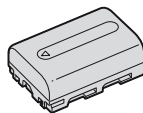

CD-ROM "Handycam Application Software" (1)

- Picture Motion Browser (software)
- Guía de PMB

Guía de operaciones (este manual) (1)

Paso 2: Recarga de la batería

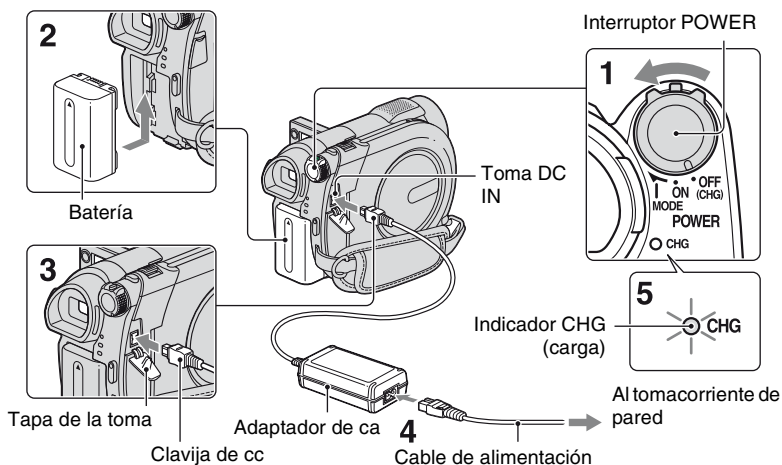

Puede recargar la batería “InfoLITHIUM” (serie H) después de colocarla en la videocámara.

Notas

- La videocámara funciona sólo con una batería “InfoLITHIUM” (serie H).

1 Deslice el interruptor POWER en el sentido de la flecha hasta la posición OFF (CHG) (ajuste predeterminado).

2 Instale la batería deslizándola en el sentido de la flecha hasta que haga clic.

3 Conecte el adaptador de ca a la toma DC IN de la videocámara.

Abra la tapa de la toma y conecte la clavija de cc en el adaptador de ca

Haga coincidir la marca ▲ de la clavija de cc con la marca ▲ de la videocámara.

4 Conecte el cable de alimentación al adaptador de ca y al tomacorriente de pared.

El indicador CHG (carga) se enciende y se inicia el proceso de recarga.

5 El indicador CHG (carga) se apaga cuando la batería está completamente cargada. Desconecte el adaptador de ca de la toma DC IN.

Notas

- Desconecte el adaptador de ca de la toma DC IN mientras sujeta la videocámara y la clavija de cc

Paso 2: Recarga de la batería (Continuación)

Para extraer la batería

- 1 Deslice el interruptor POWER hacia la posición OFF (CHG).
- 2 Deslice la palanca de liberación BATT (batería) (1) y extraiga la batería (2).

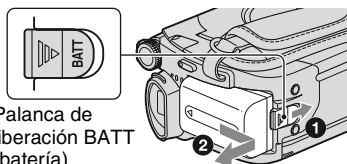

Notas

- Antes de extraer la batería o el adaptador de ca compruebe que el indicador (Película)/ (Imagen fija)/ indicador ACCESS/indicador de acceso estén apagados.
- Descargue la batería completamente antes de guardarla por un periodo extenso.

Para usar un tomacorriente de pared como fuente de alimentación

Realice las mismas conexiones que cuando recarga la batería. La batería no se descargará en ese caso.

Comprobación de la energía restante de la batería (Battery Info)

Ajuste el interruptor POWER en la posición OFF (CHG) y, a continuación, presione DISP/BATT INFO.

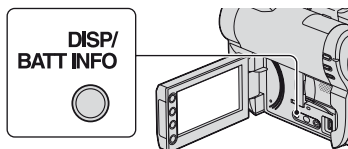

Tras un momento, se mostrarán el tiempo de grabación aproximado y la información de la batería durante 7 segundos. Puede ver la información sobre la batería durante un máximo de 20 segundos si presiona de

nuevo DISP/BATT INFO mientras aparece dicha información.

Energía restante de la batería (aprox.)

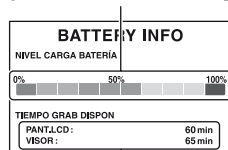

Capacidad de grabación (aprox.)

Tiempo de recarga

Tiempo aproximado (min) necesario para recargar por completo una batería totalmente descargada.

Batería	Tiempo de recarga
NP-FH40 (incluida)	125
NP-FH50	135
NP-FH70	170
NP-FH100	390

Tiempo de grabación

Tiempo aproximado (min) disponible cuando utiliza una batería completamente cargada.

Al grabar en la memoria interna (DCR-DVD810) o en un "Memory Stick PRO Duo"

DCR-DVD610

Batería	Tiempo de grabación continua	Tiempo de grabación normal (típico)*
NP-FH40 (incluida)	110	50
	120	55
NP-FH50	130	60
	140	65
NP-FH70	280	130
	300	140

Batería	Tiempo de grabación continua	Tiempo de grabación normal (típico)*
NP-FH100	625	300
	680	325

DCR-DVD710/DVD810

Batería	Tiempo de grabación continua	Tiempo de grabación normal (típico)*
NP-FH40 (incluida)	95	45
	110	50
NP-FH50	110	50
	130	60
NP-FH70	235	110
	280	130
NP-FH100	535	255
	625	300

Al grabar en un disco

DCR-DVD610

Batería	Tiempo de grabación continua	Tiempo de grabación normal (típico)*
NP-FH40 (incluida)	95	40
	100	45
NP-FH50	110	45
	120	50
NP-FH70	235	105
	255	110
NP-FH100	535	240
	580	260

DCR-DVD710/DVD810

Batería	Tiempo de grabación continua	Tiempo de grabación normal (típico)*
NP-FH40 (incluida)	80	35
	95	40
NP-FH50	95	40
	110	45
NP-FH70	205	90
	235	105
NP-FH100	470	210
	535	240

* El tiempo de grabación normal indica el tiempo de grabación al repetir las operaciones de inicio/parada, encendido/apagado de la alimentación y utilización del zoom.

Notas

- Todas las mediciones corresponden al modo de grabación [SP] bajo las siguientes condiciones:
Valor superior: Con la luz de fondo de la pantalla LCD encendida.
Valor inferior: Al grabar con el visor mientras el panel de LCD se mantiene cerrado.

Tiempo de reproducción

Tiempo aproximado (min) disponible cuando utiliza una batería completamente cargada.

Al reproducir en la memoria interna (DCR-DVD810) o en un "Memory Stick PRO Duo"

DCR-DVD610

Batería	Panel de LCD abierto*	Panel de LCD cerrado
NP-FH40 (incluida)	150	170
NP-FH50	170	195
NP-FH70	370	415
NP-FH100	830	925

Paso 2: Recarga de la batería (Continuación)

DCR-DVD710/DVD810

Batería	Panel de LCD abierto*	Panel de LCD cerrado
NP-FH40 (incluida)	140	170
NP-FH50	165	195
NP-FH70	350	415
NP-FH100	785	925

Al reproducir un disco

DCR-DVD610



Batería	Panel de LCD abierto*	Panel de LCD cerrado
NP-FH40 (incluida)	120	135
NP-FH50	140	155
NP-FH70	300	330
NP-FH100	680	745

DCR-DVD710/DVD810

Batería	Panel de LCD abierto*	Panel de LCD cerrado
NP-FH40 (incluida)	115	135
NP-FH50	135	155
NP-FH70	290	330
NP-FH100	650	745

* Con la luz de fondo de la pantalla LCD encendida.

Acerca de la batería

- Antes de cambiar la batería, deslice el interruptor POWER a la posición OFF (CHG) y apague el indicador  (Película)/indicador  (Imagen fija)/indicador ACCESS/indicador de acceso.
- El indicador CHG (carga) parpadeará durante la recarga o Battery Info no se mostrará correctamente en las siguientes situaciones:
 - La batería no está correctamente colocada.
 - La batería está dañada.

– La batería está completamente gastada (sólo para la información sobre la batería).

- No se suministrará energía de la batería mientras el adaptador de ca se encuentre conectado a la toma DC IN de la videocámara, aunque el cable de alimentación esté desconectado del tomacorriente de pared.
- Si conecta una luz de video opcional, se recomienda que utilice una batería NP-FH70/ NP-FH100 (DCR-DVD710/DVD810).
- No es recomendable utilizar una batería NP-FH30, que sólo permite realizar grabaciones y reproducciones de corta duración con la videocámara.

Acerca del tiempo de recarga / grabación / reproducción

- Tiempos calculados utilizando la videocámara a una temperatura de 25 °C (se recomienda una temperatura de 10 °C a 30 °C).
- El tiempo de grabación y de reproducción disponible será más corto cuando utilice la videocámara a bajas temperaturas.
- En función de las condiciones en las que utilice la videocámara, es posible que el tiempo de grabación y reproducción disponible se vea reducido.

Acerca del adaptador de ca

- Si utiliza el adaptador de alimentación de ca conéctelo a un tomacorriente de pared cercano. Si se produce alguna falla de funcionamiento al utilizar la videocámara, desconecte el adaptador de alimentación de ca del tomacorriente de inmediato.
- No utilice el adaptador de alimentación de ca colocado en un espacio angosto, tal como entre una pared y los muebles.
- No provoque un cortocircuito en la clavija de cc del adaptador de ca ni en el terminal de la batería con ningún objeto metálico, ya que podría ocasionar un funcionamiento inadecuado.
- Aunque la videocámara esté apagada, seguirá recibiendo adaptador de alimentación de ca (corriente doméstica) mientras esté conectada a la toma de pared mediante el adaptador de alimentación de ca

Paso 3: Conexión de la alimentación y ajuste de la fecha y la hora

Ajuste la fecha y la hora cuando utilice la videocámara por primera vez. Si no ajusta la fecha y la hora, aparecerá la pantalla [AJUS.RELOJ] cada vez que encienda la videocámara o cambie la posición del interruptor POWER.

Toque el botón que aparece en la pantalla LCD.

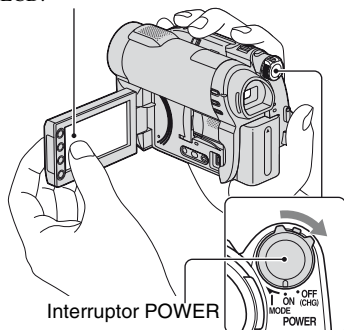

- 1** Mientras mantiene presionado el botón verde, deslice el interruptor POWER varias veces en la dirección de la flecha hasta que se encienda el indicador correspondiente.

(Película): para grabar películas

(Imagen fija): para tomar imágenes fijas

Vaya al paso 3 la primera vez que encienda la videocámara.

- 2** Toque (HOME) → (AJUSTES) → [AJ.REL./IDIOM.] → [AJUS.RELOJ]. Aparecerá la pantalla [AJUS.RELOJ].



- 3** Seleccione la zona geográfica deseada con / y luego toque [SIGUIENTE].

- 4** Ajuste el valor de [HORA VERANO] y luego toque [SIGUIENTE].

- 5** Ajuste [A] (año) mediante / .



- 6** Seleccione [M] con / , luego ajuste el mes con / .

- 7** Ajuste [D] (día), hora y minuto del mismo modo, y luego toque [SIGUIENTE].

- 8** Compruebe que el reloj esté correctamente ajustado y luego toque [OK].

El reloj se pone en funcionamiento.

Puede seleccionar cualquier año hasta el 2037.

Para la medianoche, ajuste el reloj en 12:00 am.

Paso 3: Conexión de la alimentación y ajuste de la fecha y la hora (continuación)

Para el mediodía, ajuste el reloj en 12:00 pm.

Para apagar la videocámara

Deslice el interruptor POWER hacia la posición OFF (CHG).

🔊 Notas

- Si no usa la videocámara durante **aproximadamente 3 meses**, la batería recargable integrada se descarga y es posible que los ajustes de la fecha y la hora se borren de la memoria. En este caso, cargue la batería recargable incorporada y ajuste la fecha y la hora de nuevo.
- Después de encender la videocámara, tarda unos cuantos segundos en estar lista para tomar imágenes. No es posible utilizar la videocámara durante este periodo.
- En el ajuste predeterminado, la videocámara se apaga automáticamente si no la utiliza durante aproximadamente 5 minutos, para conservar la energía de la batería ([APAGADO AUTO]).

🔊 Sugerencias

- La fecha y la hora no aparecen durante la grabación, aunque se graban automáticamente en el medio y se pueden mostrar durante la reproducción ([CÓDIGO DATOS]).
- Si los botones del panel táctil no funcionan correctamente, ajuste el panel táctil ([CALIBRACIÓN]).

Cambio del ajuste de idioma

Puede modificar las indicaciones en pantalla para que se muestren los mensajes en un idioma determinado.

Toque **HOME** → **⚙️** (AJUSTES) → [AJ.REL./IDIOM. **A**] → [AJUSTE IDIOMA **A**] y luego seleccione el idioma deseado.

Paso 4: Realización de ajustes antes de la grabación

Apertura de la tapa del objetivo

Deslice el interruptor LENS COVER hacia la posición OPEN.

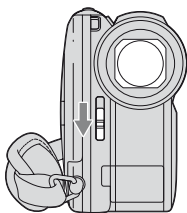

Luego de grabar, deslice el interruptor LENS COVER a la posición CLOSE para cerrar la tapa del objetivo.

Ajuste del panel de LCD

Abra el panel de LCD 90 grados con respecto a la videocámara (①) y, a continuación, gírelo en el ángulo que le resulte más adecuado para grabar o reproducir (②).

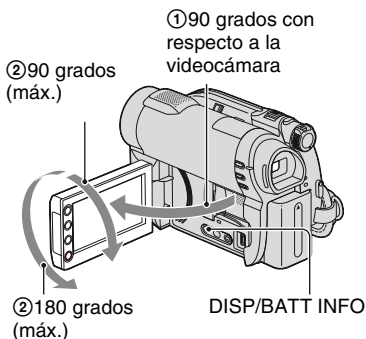

Para desactivar la luz de fondo de la pantalla LCD y conseguir que la batería dure más tiempo (DCR-DVD710/DVD810)



Mantenga presionado DISP/BATT INFO durante unos segundos hasta que aparezca .

Este ajuste resulta práctico cuando utiliza la videocámara en condiciones de mucho brillo o si desea ahorrar energía de la batería. Este ajuste no afectará a la imagen grabada. Para encender la luz de fondo de la pantalla LCD, mantenga presionado DISP/BATT INFO durante unos segundos hasta que  desaparezca.

Notas

- Tenga cuidado de no presionar los botones del marco de la pantalla LCD cuando abra o ajuste el panel de LCD.

Sugerencias

- Si abre el panel de LCD a 90 grados respecto de la videocámara y lo gira 180 grados hacia el objetivo, podrá cerrarlo con la pantalla de LCD mirando hacia fuera. Esto resulta conveniente durante operaciones de reproducción.
- Toque  (HOME) →  (AJUSTES) → [AJUS.SON./PANT.] → [BRILLO LCD] y ajuste el brillo de la pantalla LCD.
- La información se muestra o se oculta (se muestra  se oculta) cada vez que presiona DISP BATT/INFO.



Ajuste del visor

Puede usar el visor para ver las imágenes a fin de evitar el desgaste de la batería o cuando la imagen en la pantalla LCD sea de baja calidad.

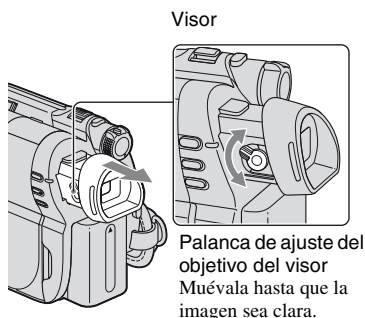
Extraiga el visor y mire a través de él. Ajuste el visor a su alcance visual.



Sugerencias

- Puede ajustar el brillo de la luz de fondo del visor al tocar  (HOME) →  (AJUSTES) → [AJUS.SON./PANT.] → [LUZ F.VISOR].

Ajuste de la correa de sujeción

Ajuste y asegure la correa de sujeción como se muestra en la ilustración y sostenga correctamente la videocámara.

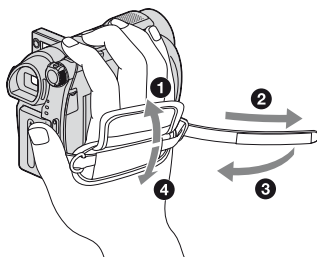

Paso 5: Selección de un medio

Puede definir en forma separada el medio que usará para películas y el que usará para imágenes fijas.

Para películas, puede seleccionar la memoria interna*, un disco o un “Memory Stick PRO Duo”. Para imágenes fijas, puede seleccionar la memoria interna*, o un “Memory Stick PRO Duo”.

DCR-DVD610/DVD710

En el ajuste predeterminado, las películas se graban en un disco. Las imágenes fijas se graban sólo en un “Memory Stick PRO Duo”.

DCR-DVD810

En el ajuste predeterminado, tanto las películas como las imágenes fijas se graban en la memoria interna.

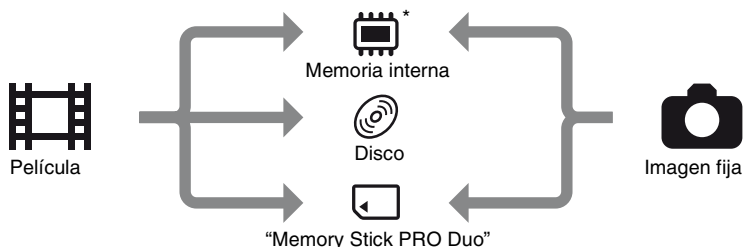

* DCR-DVD810

🔊 Notas

- Puede grabar, reproducir o editar imágenes en el medio seleccionado. Al grabar, reproducir o editar imágenes en otro medio, seleccione el medio nuevamente.

Selección de un medio para películas

- 1 Toque **HOME** → **GESTIONAR SOPORTE** → **AJ.SOPORTE PEL.**
Aparece la pantalla de ajuste de medio para películas.



- 2 Toque el medio deseado.

- 3 Toque **[SÍ]**.

- 4 Cuando aparezca **[Finalizado.]**, toque **[OK]**.
Cambié el medio para películas.

Selección de un medio para imágenes fijas (DCR-DVD810)

- 1 Toque  (HOME) →  (GESTIONAR SOPORTE) → [AJ.SOPORTE FOTO].

Aparece la pantalla de ajuste de medio para imágenes fijas.



- 2 Toque el medio deseado.

Notas



- No es posible seleccionar un disco como medio para imágenes fijas.

- 3 Toque [SÍ].

- 4 Cuando aparezca [Finalizado.], toque [OK].

Cambió el medio para imágenes fijas.

Para confirmar el medio seleccionado

- ① Deslice el interruptor POWER para encender el indicador del modo  (Película)/  (Imagen fija) en que desea comprobar el medio.
- ② Verifique el icono de medio que aparece en la esquina superior izquierda de la pantalla.

Icono de medio



Memoria interna*



Disco (el icono difiere según el tipo de disco.)



“Memory Stick PRO Duo”

* DCR-DVD810

Paso 6: Inserción de un disco o un “Memory Stick PRO Duo”

Si selecciona [MEMORIA INTERNA] en el “Paso 5”, la operación de este paso es innecesaria (DCR-DVD810).

Inserción de un disco

Si selecciona [DISCO] en el “Paso 5”, se necesita un nuevo DVD-RW, DVD+RW, DVD-R o DVD+R DL de 8 cm

Notas

- Antes de utilizarlo, elimine el polvo y las huellas dactilares del disco con un paño suave.

1 Verifique que la videocámara esté encendida.

2 Deslice el interruptor OPEN de la cubierta del disco en la dirección que indica la flecha (OPEN →).

[ABRIENDO...] aparece en la pantalla. La cubierta del disco se abre levemente en forma automática.

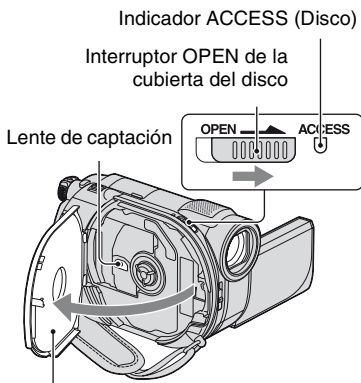

Cuando la cubierta del disco se abra levemente, ábrala más.

3 Coloque el disco con la cara de grabación hacia la videocámara y presione el centro del disco hasta que haga clic.

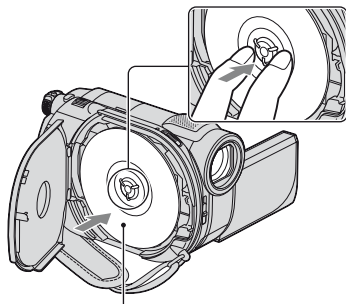

Si usa un disco de una sola cara, colóquelo con la etiqueta orientada hacia afuera.

4 Cierre la cubierta del disco.

[ACCESO A DISCO] aparece en la pantalla.

Es posible que la videocámara tarde un momento en reconocer el disco.

■ DVD-RW/DVD+RW

Aparece una pantalla que pregunta si desea utilizar [GUÍA SELEC.DISCO]. Usar [GUÍA SELEC.DISCO] le permite formatear el disco siguiendo las instrucciones en pantalla. Si no desea usarla, avance al paso 5.

■ DVD-R/DVD+R DL

Puede comenzar a grabar inmediatamente después de que [ACCESO A DISCO] desaparece de la pantalla. No es necesario que avance a los pasos posteriores al paso 5.

5 Toque la opción que desee en la pantalla.

■ DVD-RW

Seleccione el formato de grabación, [VIDEO] o [VR], y luego toque **[OK]**.

■ DVD+RW

Seleccione la relación de aspecto de la película, [PANORÁM.16:9] o [4:3], luego toque **[OK]**.

6 Toque [SÍ].

7 Cuando aparezca [Finalizado.], toque **[OK]**.

Cuando el proceso de formateo finalice, puede comenzar a grabar en disco.

💡 Sugencias

- Si usa un DVD-RW mientras está ajustado el funcionamiento en modo Easy Handycam, el formato de grabación se fija en el modo VIDEO.

Para extraer el disco

- ① Realice los pasos **1** y **2** para abrir la cubierta del disco.
- ② Presione el soporte del disco en el centro del compartimento del disco y retire el disco sosteniéndolo por el borde.

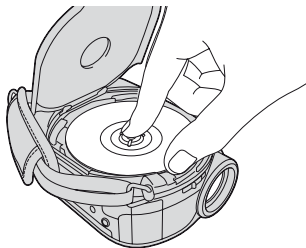

🔊 Notas

- Asegúrese de no obstruir la operación con su mano u otros objetos al abrir o cerrar la cubierta del disco. Mueva la correa hacia la parte inferior de la videocámara y luego abra o cierre la cubierta del disco.
- Si la correa queda atrapada al cerrar la cubierta del disco, podría causar una falla en el funcionamiento de la videocámara.
- No toque el lado de grabación del disco ni el lente de captación.
Si usa un disco de dos caras, tenga cuidado de no ensuciar la superficie con huellas dactilares.
- Si éste no está colocado correctamente al cerrar la cubierta del disco, es posible que cause una falla de funcionamiento en la videocámara.
- No desconecte las fuentes de alimentación mientras formatea el disco.
- No golpee ni sacuda la videocámara puesto que está leyendo y escribiendo en el disco:
 - mientras el indicador ACCESS está encendido
 - mientras el indicador ACCESS está parpadeando
 - mientras [ACCESO A DISCO] o [ABRIENDO...] aparecen en la pantalla LCD
- Puede transcurrir cierto tiempo hasta que se extraiga el disco, dependiendo del contenido grabado.
- Si un disco está rayado o sucio con huellas dactilares, pueden transcurrir hasta 10 minutos antes de extraerlo. Si eso sucede, es posible que el disco esté dañado.

💡 Sugencias

- Puede insertar o extraer el disco cuando la videocámara esté conectada a una fuente de alimentación, incluso si está apagada. Sin embargo, no se inicia el proceso de reconocimiento del disco (paso 4).
- Puede comprobar si está usando el disco correcto al usar la [GUÍA SELEC.DISCO] en el HOME MENU.

Paso 6: Inserción de un disco o un “Memory Stick PRO Duo” (Continuación)

Inserción de un “Memory Stick PRO Duo”

Esta operación es necesaria sólo si selecciona [MEMORY STICK] en el “Paso 5”.

💡 Sugerencias

- Si sólo graba imágenes fijas en el “Memory Stick PRO Duo”, no son necesarias las operaciones posteriores al paso 3.

1 Abra el panel de LCD.

2 Inserte el “Memory Stick PRO Duo”.

- 1 Abra la cubierta del Memory Stick Duo hacia la dirección de la flecha.
- 2 Coloque el “Memory Stick PRO Duo” en la ranura para Memory Stick Duo en la orientación correcta hasta que haga clic.
- 3 Cierre la cubierta del Memory Stick Duo.

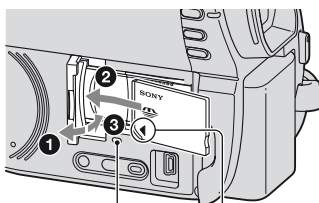

Indicador de acceso

Coloque la marca ◀ hacia el lado de la pantalla LCD.

3 Si selecciona [MEMORY STICK] en el “Paso 5” para la grabación de películas, deslice el interruptor POWER varias veces hasta que se encienda el indicador (Película).

Si el interruptor POWER está ajustado en OFF (CHG), deslícelo mientras mantiene presionado el botón verde.

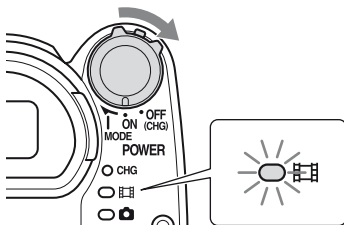

Aparece la pantalla [Crear nuevo arch.base de datos de imágenes.] al insertar un nuevo “Memory Stick PRO Duo”.

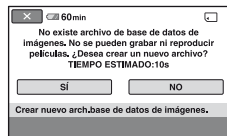

4 Toque [SÍ].

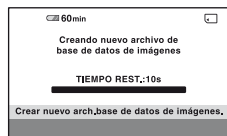

Para extraer el “Memory Stick PRO Duo”

Abra el panel de LCD y la cubierta del Memory Stick Duo. Empuje levemente el “Memory Stick PRO Duo” una vez y luego desléclo hacia fuera de la ranura.

🔊 Notas

- Para evitar daños en los medios o la pérdida de imágenes grabadas, no realice ninguna de las siguientes acciones mientras el indicador de acceso está encendido:
 - extraer la batería o el adaptador de ca de la videocámara
 - someter la videocámara a golpes o a vibraciones
 - extraer el “Memory Stick PRO Duo” de la videocámara
- No abra la cubierta del Memory Stick Duo mientras realiza una grabación.
- Insertar “Memory Stick PRO Duo” a la fuerza en la dirección incorrecta puede causar un mal funcionamiento del “Memory Stick PRO Duo”, de la ranura para Memory Stick Duo o de los datos de imagen.
- Si [Error al crear un nuevo archivo de base de datos de imágenes. Es posible que no exista suficiente espacio libre.] aparece en el paso 4, formatee el “Memory Stick PRO Duo”. Todos los datos grabados en el “Memory Stick PRO Duo” se eliminarán al formatearlo.
- No presione ni extraiga el “Memory Stick PRO Duo” por la fuerza, ya que podría ocasionar un funcionamiento inadecuado.

Tiempo de grabación de películas en un “Memory Stick PRO Duo”

Las cifras de la tabla indican el tiempo de grabación aproximado en minuto del “Memory Stick PRO Duo”.

Las cifras en () indican el tiempo de grabación mínimo.

Modo de grabación	9M (HQ) (calidad alta)	6M (SP) (calidad estándar)	3M (LP) (larga duración)
512MB	6 (5)	9 (5)	15 (10)
1GB	10 (10)	20 (10)	35 (25)
2GB	25 (25)	40 (25)	80 (50)
4GB	55 (50)	80 (50)	160 (105)
8GB	115 (100)	170 (100)	325 (215)

🔊 Notas

- Los números de la tabla corresponden a la utilización de un “Memory Stick PRO Duo” fabricado por Sony Corporation. El tiempo de grabación varía según las condiciones de grabación, el tipo de “Memory Stick” o el ajuste de [MODO GRAB.].
- Cuando el tiempo de grabación es menor a 5 minutos, aparece .

Grabación

Las imágenes se graban en el medio seleccionado en el ajuste de medio.

DCR-DVD610/DVD710

En el ajuste predeterminado, las películas se graban en un disco. Las imágenes fijas se graban sólo en un "Memory Stick PRO Duo".

DCR-DVD810

En el ajuste predeterminado, tanto las películas como las imágenes fijas se graban en la memoria interna.

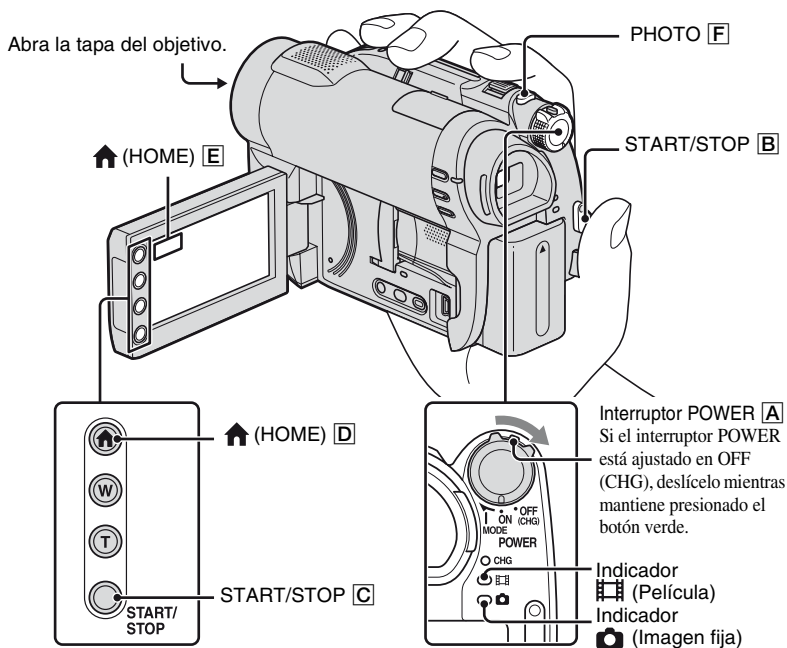

⚙️ Notas

- Si los indicadores de ACCESS/acceso están encendidos o parpadean después de finalizada la grabación, significa que todavía se están escribiendo datos en el medio. No golpee ni sacuda la videocámara y no desconecte la batería o el adaptador de ca
- Si [MEMORIA INTERNA] (DCR-DVD810) o [MEMORY STICK] está seleccionado en [AJ.SOPORTE PEL.], cuando un archivo de película supera los 2 GB, el siguiente archivo de película se crea automáticamente.

Sugerencias

- Puede consultar el espacio libre para películas en el medio al tocar **HOME** → **GESTIONAR SOPORTE** → **[INFO SOPORTE]**.

Películas



- 1 Deslice el interruptor **POWER** **A** hasta que se encienda el indicador **película** (Película).

- 2 Presione **START/STOP** **B** (o **C**).

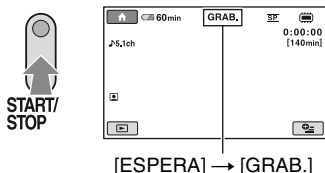

Para detener la grabación, presione **START/STOP** de nuevo.

Notas

- No puede grabar imágenes fijas en un disco.

Sugerencias

- **ícono de cámara** aparece cuando **[AJUSTE INDEX]** está ajustado en **[ACTIVADO]** (el ajuste predeterminado) durante la grabación de películas.
- Puede cambiar la grabación entre película e imagen fija al tocar **HOME** **D** (o **E**) → **TOMA DE IMÁGENES** → **[PELÍCULA]** o **[FOTO]**.
- Puede crear imágenes fijas a partir de las películas grabadas.

Imágenes fijas



- 1 Deslice el interruptor **POWER** **A** hasta que se encienda el indicador **imagen fija** (Imagen fija).

- 2 Presione **PHOTO** **F** ligeramente para enfocar **A** (se oye un pitido), luego presione completamente **B** (se oye el clic del obturador).

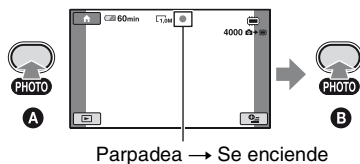

ícono de cámara aparece junto a **ícono de batería** o **ícono de batería**. Cuando **ícono de cámara** desaparece, significa que se ha grabado la imagen.

Reproducción

Puede reproducir imágenes grabadas en el medio seleccionado en el ajuste de medio.

DCR-DVD610/DVD710

En el ajuste predeterminado, se reproducen las películas de un disco. Las imágenes fijas se graban y se reproducen sólo en un "Memory Stick PRO Duo".

DCR-DVD810

En el ajuste predeterminado, se reproducen las imágenes de la memoria interna.

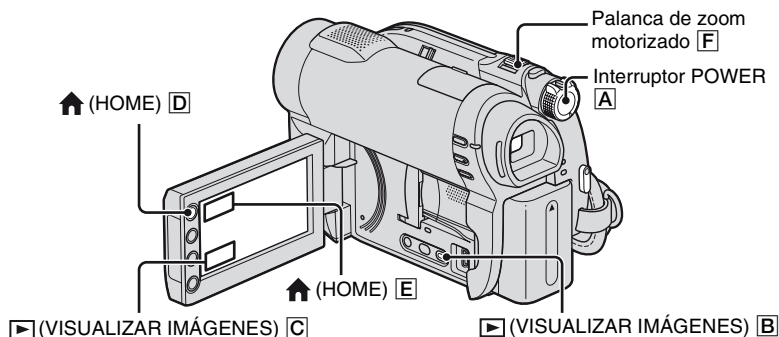

1 Deslice el interruptor POWER [A] para encender la videocámara.

2 Presione ▶ (VISUALIZAR IMÁGENES) [B] (o [C]).

La pantalla VISUAL INDEX aparece en la pantalla LCD. (Puede que las miniaturas tarden un momento en aparecer.)

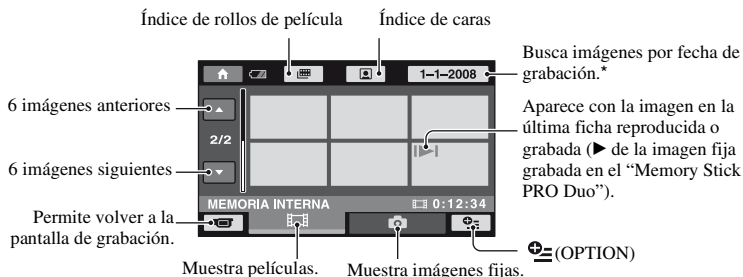

* Al seleccionar [DISCO] en [AJ.SOPORTE PEL.], aparece un tipo de disco. No puede buscar películas por fecha de grabación.

Sugerencias

- El número de imágenes que aparece en la pantalla VISUAL INDEX se puede cambiar entre 6 ↔ 12 al mover la palanca del zoom motorizado [F]. Para fijar este número, toque **HOME** [D] (o [E]) → **(AJUSTES)** → [VIEW IMAGES SET] → [DISPLAY].

3 Iniciar reproducción.

Películas



Toque la ficha y la película que desea reproducir.

Cuando la reproducción desde la película seleccionada llega a la última película, la pantalla regresa a la pantalla VISUAL INDEX.

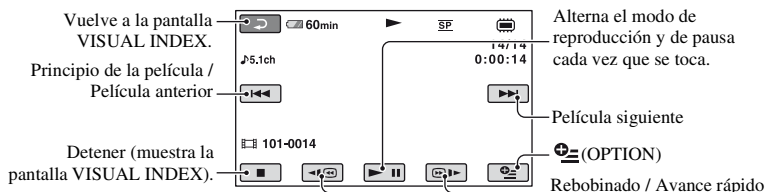

Sugerencias

- Toque / durante la pausa para reproducir la película a cámara lenta.
- Al reproducir películas desde la memoria interna (DCR-DVD810) o desde un "Memory Stick PRO Duo", un toque de / hace que la película retroceda o avance 5 veces más rápido que lo normal, 2 toques aumenta la velocidad 10 veces, 3 toques aumenta la velocidad 30 veces y 4 toques aumenta la velocidad aproximadamente 60 veces.
- Al reproducir las películas de un disco, un toque de / hace que la película retroceda o avance 5 veces más rápido que lo normal, 2 toques aumenta la velocidad 10 veces (alrededor de 8 veces más rápido en el caso de un DVD+RW).

Imágenes fijas





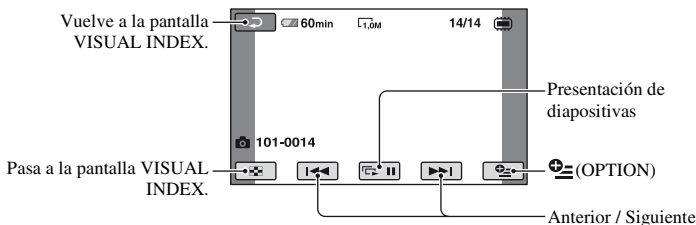

Toque la ficha y la imagen fija que desee reproducir.







Reproducción (Continuación)

Ajustar el volumen del sonido de las películas

Al reproducir películas, toque  (OPTION) → ficha  → [VOL.] y luego ajuste el volumen con  / .

Sugerencias

- Puede cambiar la pantalla a VISUAL INDEX al tocar  (HOME)  (o ) →  (VISUALIZAR IMÁGENES) → [VISUAL INDEX].

