

SONY®

DIGITAL VIDEO CAMERA

DXC-D30WS

DXC-D30WSP

SERVICE MANUAL

Vol. 1 (1st Edition)

Power HAD WS

CAUTION

Danger of explosion if battery is incorrectly replaced.

Replace only with the same or equivalent type recommended by the manufacturer.
Dispose of used batteries according to the manufacturer's instructions.

Vorsicht!

Explosionsgefahr bei unsachgemäßem Austausch der Batterie.

Ersatz nur durch denselben oder einen vom Hersteller empfohlenen ähnlichen Typ.
Entsorgung gebrauchter Batterien nach Angaben des Herstellers.

ATTENTION

Il y a danger d'explosion s'il y a remplacement incorrect de la batterie.

Remplacer uniquement avec une batterie du même type ou d'un type équivalent recommandé par le constructeur.
Mettre au rebut les batteries usagées conformément aux instructions du fabricant.

ADVARSEL!

Lithiumbatteri-Eksplosionsfare ved fejlagtig håndtering.

Udskiftning må kun ske med batteri af samme fabrikat og type.
Levér det brugte batteri tilbage til leverandøren.

ADVARSEL

Lithiumbatteri - Eksplosjonsfare.
Ved utskifting benyttes kun batteri som anbefalt av apparatfabrikanten.
Brukt batteri returneres apparatleverandøren.

VARNING

Explosionsfara vid felaktigt batteribyte.
Använd samma batterityp eller en likvärdig typ som rekommenderas av apparattillverkaren.
Kassera använt batteri enligt gällande föreskrifter.

VAROITUS

Paristo voi räjähtää jos se on virheellisesti asennettu.
Vaihda paristo ainoastaan laitevalmistajan suosittelemaan tyyppiin.
Hävitä käytetty paristo valmistajan ohjeiden mukaisesti.

MANUAL STRUCTURE

Introducing this manual

This manual is the Service Manual Vol. 1 of the DIGITAL VIDEO CAMERA DXC-D30WS and DXC-D30WSP.

This manual contains the operation manual related to the operations of this equipment, the replacement of the parts and adjustments.

Related manuals

In addition to this Service Manual Vol. 1, the following manuals are provided.

- **Service Manual Vol. 2**

Part No. 9-977-326-21

Contains block diagrams, board layouts, schematic diagrams, semiconductor pin assignments and parts lists.

- **Service Manual DXF-701/701CE/701WS/701WSCE**

Part No. 9-977-265-02

See the DXF-701/701CE/701WS/701WSCE service manual available separately.

- **Service Manual VCT-U14**

Part No. 9-977-221-01

See the VCT-U14 service manual available separately.

- **Service Manual VCL-918BY**

Part No. 9-977-329-01

See the VCL-918BY service manual available separately.

TABLE OF CONTENTS

1. OPERATING INSTRUCTIONS

2. SERVICE INFORMATION

2-1. BOARD LAYOUT	2-1
2-2. REMOVAL OF CABINET	2-1
2-2-1. Removal of Side Plate	2-1
2-2-2. Cautions on Disassembly/Assembly of Top Chassis	2-2
2-3. REPLACEMENT OF MAIN PARTS	2-2
2-3-1. Replacement of CCD Unit	2-2
2-4. CONNECTORS AND CABLES	2-4
2-4-1. Connector Input/Output Signals	2-4
2-4-2. Connection Connector	2-8
2-5. HOW TO HANDLE OF AT-125 BOARD	2-8
2-5-1. How to Attach of the Extention Board EX-591	2-8
2-5-2. Replacement Way of ROM(IC102)	2-8
2-6. DC-DC CONVERTER VOLTAGE	2-9
2-7. SERVICE MODE OPERATION	2-10

3. ALIGNMENT

3-1. PREPARATION	3-1
3-1-1. Equipment Required	3-1
3-1-2. Connection	3-1
3-1-3. Switch Setting Before Adjustment	3-2
3-1-4. Notes on Adjustment	3-2
3-1-5. Adjustment Item	3-3
3-2. BEFORE ADJUSTMENT	3-4
3-2-1. Color Bar Signal Confirmation	3-4
3-2-2. Sensitivity Measurement Confirmation	3-4
3-3. CAMERA ADJUSTMENT	
3-3-1. Sub-Carrier Frequency Adjustment	3-5
3-3-2. INT SC-H Phase Adjustment	3-5
3-3-3. Y/R-Y/B-Y CLP Level Adjustment	3-5
3-3-4. Y/SYNC/R-Y/B-Y Level Adjustment	3-6
3-3-5. Carrier Balance Adjustment	3-6
3-3-6. Chroma (VBS) Level Adjustment	3-7
3-3-7. Y (VBS) Level Adjustment	3-7
3-3-8. Y (YC) Level Adjustment	3-8
3-3-9. Chroma (YC) Level Adjustment	3-8
3-3-10. VF SYNC/BLKG Level Adjustment	3-9
3-3-11. CCD Output Level Adjustment	3-9
3-3-12. Pedestal Adjustment	3-10
3-3-13. Shading Adjustment	3-10
3-3-14. Flare Adjustment	3-11
3-3-15. MIC LEVEL/MIC Level IND Adjustment ...	3-11
3-3-16. Character Position Adjustment	3-12
3-3-17. 4 : 3 Title Adjustment	3-12

SONY[®]

3-861-659-01(1)

1-1. DXC-D30WS/D30WSP

***Digital Video
Camera***

Operating instructions Page 12

**SECTION 1
OPERATING INSTRUCTIONS**

This section is extracted
from operation manual.

**Power LITHIUM ION
DXC-D30WSL/D30WSPL**

© 1997 by Sony Corporation

For the customers in the USA

This equipment has been tested and found to comply with the limits for a Class A digital device, pursuant to Part 15 of the FCC Rules. These limits are designed to provide reasonable protection against harmful interference when the equipment is operated in a commercial environment. This equipment generates, uses, and can radiate radio frequency energy and, if not installed and used in accordance with the instruction manual, may cause harmful interference to radio communications. Operation of this equipment in a residential area is likely to cause harmful interference in which case the user will be required to correct the interference at his own expense.

You are cautioned that any changes or modifications not expressly approved in this manual could void your authority to operate this equipment.

The shielded interface cable recommended in this manual must be used with this equipment in order to comply with the limits for a digital device pursuant to Subpart B of Part 15 of FCC Rules.

Table of Contents

Overview	14
About This Manual	14
Features	14
Advanced Menu Settings.....	15
Video Output and Viewfinder Picture.....	16
Battery Pack Operating Times	17
Specifications	18
Related Products	19
Measuring Horizontal Resolution	21
Chart of Optional Components and Accessories	22

Overview

About This Manual

This booklet constitutes an operation manual for DXC-D30WSL/D30WSPL 16:9 wide-screen type digital video camera together with the common Operating Instructions for the DXC-D30 series of digital video cameras.¹⁾

This book describes only the differences between the DXC-D30WSL/D30WSPL and other DXC-D30 series digital video cameras. For information about general camera operations, handling precautions and so forth, consult the common Operating Instructions for the DXC-D30 series cameras.

When reading the common Operating Instructions, please keep it in mind that "D30" in the camera model name should be replaced with "D30WS" and that "701" in the viewfinder model name should be replaced with "701WS."

Features

The DXC-D30WSL/D30WSPL is a 16:9 wide-screen type digital video camera. It combines the superior performance of the DXC-D30L/D30PL 4:3 standard-screen type digital video camera with the following features.

²/₃-inch IT Type Power HAD WS CCD

The DXC-D30WSL/D30WSPL uses a newly developed 520,000-pixel Power HAD WS (wide screen) CCD, for outstanding sensitivity and picture quality.

- Sensitivity: F11.0 (at 3200 K, 2000 lx)
- S/N: 63 dB
- Smear: -120 dB

Switchable between 16:9 and 4:3 aspect ratios

A simple menu operation provides instant switching between the 16:9 and 4:3 aspect ratios. In 4:3 mode, a screen equivalent to a 4:3 screen is obtained through digital processing of the 16:9 video signals produced by the WS CCD.

Wide-aspect ID signals

A menu setting is available to add wide-aspect ID signals²⁾ to 16:9-mode video signals.³⁾

Automatic aspect ratio switching in viewfinder

When the supplied viewfinder (DXF-701WS/701WSCE) is used, the viewfinder scan size (16:9 or 4:3) automatically switches in accordance with the aspect ratio selected for the camera.

For details, see pages 15 and 16.

White balance setting for color temperature of 3000 K

Preset white balance settings are provided for color temperatures of 3200 K and 5600 K. In addition, a menu selection allows use of a preset white balance setting for 3000 K. This feature facilitates shooting under low color temperature light from for example, incandescent lamps. It also facilitates color balance coordination between this camera and those cameras from other manufacturers whose preset white balance values are only for relatively low color temperature.

See page 15 for instructions on how to use the menu to select the preset white balance setting for 3000 K.

- 3) Video signals refers to the following:
- Video signals output from the VIDEO OUT connector and MONITOR OUT connector.
 - The Y component of Y/C separate signals and the Y component of component signals output from the VTR connector.

- 1) DXC-D30F/D30PF/D30K/D30PK/D30L/D30PL/D30H/D30PH
 2) ID signals complying with EIAJ CPR-1204 (DXC-D30WSL) or complying with ETS WSS (DXC-D30WSPL).

Advanced Menu Settings

The Advanced menu of the DXC-D30WSL/D30WSPL camera differs from the Advanced Menu of the DXC-D30 cameras in the following ways.

Advanced menu page 3

For the DXC-D30WSL/D30WSPL, the item "PRE. WHT" has been added to page 3 of the Advanced menu (see page 58 of the common Operating Instructions for the DXC-D30 series).

	PAGE 3 (NEXT→ PREVIOUS←)
→	AWB MEM : 2
→	(PRE. WHT) : 3200
	TONE : OFF
	BARS : SMPTE
	REMOTE1 : REC
	REMOTE2 : MARK
	BAUD RATE : 38400
	EXIT MENU (YES→)

Item	Settings
PRE. WHT Selects the preset white balance setting made available when the FILTER knob is set to position 1.	3200: White balance for 3200 K 3000: White balance for 3000 K

Advanced menu page 7

On page 7 of the DXC-D30 series Advanced menu (see page 60 of the common Operating Instructions) there is a menu item A.IRIS. This item can be set to either STD (standard value) or AI (artificial intelligence).

In the DXC-D30WSL/D30WSPL, the STD mode has been enhanced by incorporating functions from the AI mode. Therefore the A.IRIS menu item was abolished.

Advanced menu page 9

A page was added to the Advanced menu of the DXC-D30WSL/D30WSPL to permit aspect ratio settings. This menu page was numbered page 9. Pages 9 and following from the DXC-D30 series Advanced menu were renumbered as pages 10 and following, as shown below.

Advanced menu page numbers

DXC-D30 series	DXC-D30WSL/D30WSPL
Page 9	→ Page 10
Page 10	→ Page 11
Page 11	→ Page 12
Page 12	→ Page 13
Page 13	→ Page 14
Page 14	→ Page 15

The items on page 9 of the DXC-D30WSL/D30WSPL Advanced menu are shown below.

	PAGE 9 (NEXT→ PREVIOUS←)
→	16:9/4:3 : 16:9
	WIDE ID : ON
	VF SCAN : AUTO
	EXIT MENU (YES→)

Item	Settings
16:9/4:3 Selects whether to put the camera in 16:9 mode or 4:3 mode.	16:9, 4:3^{a)}
WIDE ID Selects whether or not to add a wide aspect ID signal to video output signals in 16:9 mode.	ON: Add OFF: Do not add
VF SCAN Selects 16:9 or 4:3 as the viewfinder scan size when using the supplied viewfinder (DXF-701WS/701WSCE).	AUTO: Automatically switch to 16:9 size when the camera is in 16:9 mode, and automatically switch to 4:3 size when the camera is in 4:3 mode. ^{b)} FULL: Regardless of camera's mode (16:9 ^{b)} or 4:3), the viewfinder picture completely fills the display area.

a) Compared to 16:9 mode, the 4:3 mode video appears as if a zoom lens has been adjusted slightly toward the telephoto end (see figure on next page).

b) When the camera is in 16:9 mode, the viewfinder picture appears stretched vertically (see figure on next page).

Advanced Menu Settings

Video Output and Viewfinder Picture

The video output and viewfinder picture of this camera vary as shown below according to the settings of the 16:9/4:3 item and the VF SCAN item of the Advanced menu.

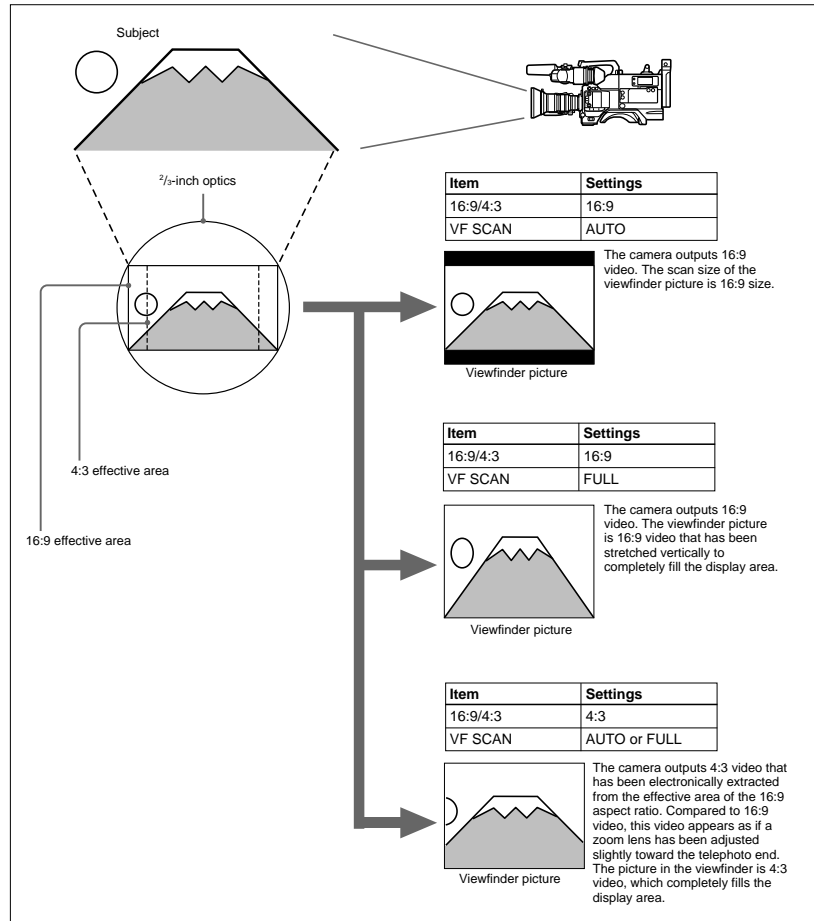

Battery Pack Operating Times

The following table shows the maximum continuous operating times when this camera (including viewfinder) is operated at normal temperature under battery pack power. The times varies depending on the battery pack and attached equipment.

Battery pack	When the camera is coupled to:	
	Camera adaptor	Portable VTR (DSR-1/1P or PVV-3/3P)
NP-1B	Approx. 90 minutes	Approx. 50 minutes
NP-1A	Approx. 70 minutes	Approx. 35 minutes
BP-90A ^{a)}	—	Approx. 105 minutes

a) The DC-500 battery case is required when using the BP-90A battery pack. The BP-90A cannot be used when a camera adaptor is coupled to the camera.

Specifications

DXC-D30WSL/D30WSPL Camera Head

Imaging element	Three-chip interline transfer CCD
Pixel resolution	980 (horizontal) × 494 (vertical) (DXC-D30WSL) 980 (horizontal) × 582 (vertical) (DXC-D30WSPL)
Imaging area	9.6 × 5.4 mm (3/8-inch)
Built-in filter settings	1: 3200K (3000K) 2: 5600K + 1/8ND 3: 5600K 4: 5600K + 1/64ND
Lens mount	Bayonet mount
Signal standards	EIA standard signal (NTSC color system) (DXC-D30WSL) CCIR standard signal (PAL color system) (DXC-D30WSPL)
Scanning system	525 lines, 2:1 interlace (DXC-D30WSL) 625 lines, 2:1 interlace (DXC-D30WSPL)
Scanning frequencies	Horizontal: 15.734 kHz (DXC-D30WSL) 15.625 kHz (DXC-D30WSPL) Vertical: 59.94 Hz (DXC-D30WSL) 50.00 Hz (DXC-D30WSPL)
Synchronization	Internal sync External sync, using signal input (VBS or BS) to the GEN LOCK IN connector of an optional camera adaptor or input from the GEN LOCK connector of a CCU-M5/M5P/M7/M7P camera control unit to the VTR/CCU/CMA connector of an optional camera adaptor.
Horizontal resolution ¹⁾	16:9: 700 TV lines 4:3: 700 TV lines
Minimum illumination	0.5 lx (at F1.4, +36 dB) 0.8 lx (at F1.8, +36 dB)
Sensitivity	F11 at 2000 lx (3200K, 89.9% reflectance) (typical)

Gain levels	Selectable -3 dB, 0 dB, 3 dB, 6 dB, 9 dB, 12 dB, 18 dB, 18 dB + DPR, 24 dB, 24 dB + DPR, hyper gain (30 dB + DPR)
Video output	Composite signal 1.0 Vp-p, sync negative, 75 Ω, unbalanced Y/C separate signals Y: 1.0 Vp-p, sync negative, unbalanced C: burst level 0.286 Vp-p (DXC-D30WSL) or 0.300 Vp-p (DXC-D30WSPL), no sync
Video S/N ratio	63 dB (typical) (DXC-D30WSL) 61 dB (typical) (DXC-D30WSPL)
Registration	0.05% for all zones, without lens
Input/output connectors	VIDEO OUT connector: BNC, 75 Ω, unbalanced LENS connector: 12-pin, for 2 3/8-inch lens VF connector (front): 20-pin VF connector (left side): 8-pin REMOTE connector 1: Stereo mini-jack REMOTE connector 2: 10-pin MONITOR OUT connector: BNC, 75 Ω, unbalanced
Power supply	12 V DC
Power consumption	14.9 W (camera proper; 15.3 W when connected with DSR-1/1P) 17 W (when fitted with viewfinder)
Operating temperature	-10 °C to +45 °C (14 °F to 113 °F)
Storage temperature	-20 °C to +60 °C (-4 °F to 140 °F)
Mass	2.5 kg approx. (5 lb 8 oz)

External dimensions in millimeters (inches)

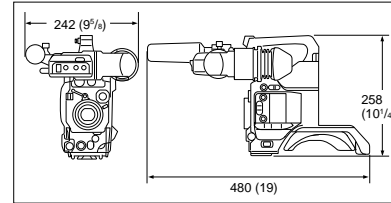

DXF-701WS/701WSCE Viewfinder

Picture tube	1.5-inch monochrome
Indicators	REC/TALLY (×2), TAKE, BATT, SHUTTER, GAIN UP
Resolution	600 TV lines
Power supply	12 V DC
Power consumption	2.1 W
Mass	660 g approx. (1 lb 7 oz)
Maximum external dimensions	236 (W) × 85 (H) × 219 (D) mm (9 3/8 × 3 3/8 × 8 5/8 inches)
Scan size	Switchable between 16:9 and 4:3

Supplied accessories

DXF-701WS/701WSCE Viewfinder (1)
RM-LG1 Remote Control Unit (1)
Microphone (1)
Wind screen (1)
VCT-U14 Tripod Adaptor (1)
Lens mount cap (1)
Flange focal length adjustment test chart (1)
Operating Instructions (common to DXC-D30 Series) (1)
Operating Instructions (for DXC-D30WSL/D30WSPL only) (1)
Operating Instructions (for RM-LG1) (1)
ClipLink™ Guide (1)

Design and specifications are subject to change without notice.

Related Products

There is a range of Sony products available to meet every conceivable video shooting requirement. For details, consult your Sony sales representative or supplier.

Lenses

VCL-915BYA/916BYA/916BY/918BY/1012BY
Zoom Lens

Camera adaptor products

CA-325A/325AP/325B/327/327P/511/512¹⁾/512P¹⁾/
513/537/537P Camera Adaptor
CMA-8A/8ACE AC Adaptor
RM-M7G Camera Remote Control Unit

VTR products

DSR-1/1P Digital Videocassette Recorder
EVP-9000/9000P Videocassette Recorder
PVV-1/1P/1A/1AP/3/3P Portable Videocassette Recorder
VO-8800/8800P Portable Videocassette Recorder
BVU-150/150P Portable Videocassette Recorder
BVV-5/5PS Videocassette Recorder
BVW-50/50P Portable Videocassette Recorder
VA-5/5P/90/90P VTR Adaptor

Battery products

NP-1B Battery Pack
BP-90A Battery Pack
BC-1WD/1WDCE/410/410CE Battery Charger

Microphone products

ECM-670/672 Electret Condenser Microphone
C-74 Condenser Microphone
CAC-12 Microphone Holder
EC-0.5C2 Microphone Cable
EC-0.3C2 Microphone Cable

Studio equipment

CCU-M5/M5P/M7/M7P Camera Control Unit
DFS-300/300P/500/500P DME Switcher
DCK-500/500P Chroma Key Unit
DXF-51 5-inch Viewfinder (monochrome)
DXF-41 4-inch Viewfinder (monochrome)

1) About horizontal resolution measurement, see page 21.

1) When connecting a CA-512/512P, remove the blank panel on the CA-512/512P.

Specifications

Cables and miscellaneous

The suffix number on a cable part number indicates the length in meters: e.g. a CCZ-A2 is 2 meters long. (Approximate equivalents in feet: 2 m = 6 ft, 5 m = 16 ft, 10 m = 33 ft, 25 m = 82 ft, 50 m = 164 ft, 100 m = 328 ft)

Camera cables with Z-type 26-pin connectors
CCZ-A2/A5/A10/A25/A50/A100

Camera cables with Q-type 14-pin connectors
CCZQ-A2/A5/A10/A2AM

CCZZ-1B/1E Cable Extension Connector

Camera cables with Q-type 14-pin connectors
CCQ-2BRS/5BRS/10BRS
CCQ-10AM/25AM/50AM/100AM

LC-421 Carrying Case

LCR-1 Rain Cover

CAC-4 Chest Pad

LC-304SFT Soft Case

Measuring Horizontal Resolution

The number of effective pixels of this camera in horizontal direction is 980. However, when horizontal resolution measurement is executed using a 4:3 resolution chart, the results show a horizontal resolution of approximately 700 TV lines for both 16:9 mode and 4:3 mode as described below.

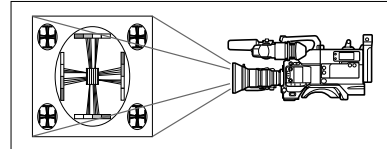

Horizontal resolution in 16:9 mode

When the horizontal image frame of this camera is aligned with the width of the 4:3 resolution chart, the resolution is about 935 TV lines (see Figure A). However, to measure the resolution of a video camera precisely, the vertical image frame must be aligned with the height of the chart. When this is done, the resolution is approximately 700 (935 × 3/4) TV lines (see Figure B).

Horizontal resolution in 4:3 mode

In 4:3 mode, frame memory is used to extract the 4:3 area from the 16:9 video signals produced by the WS CCD, and the 4:3 signals are electronically enlarged. As a result, the horizontal resolution is approximately 700 TV lines, the same as for 16:9 mode (see Figure C).

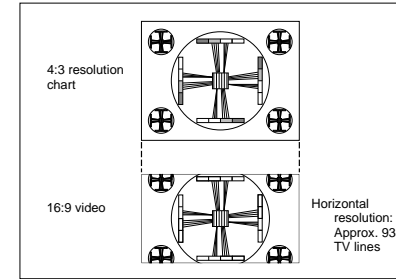

Figure A.

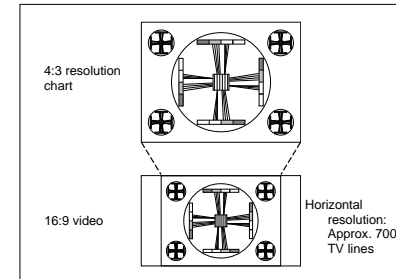

Figure B.

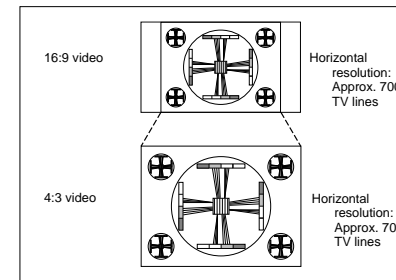

Figure C.

Chart of Optional Components and Accessories

SONY®

3-858-217-14(1)

1-2. DXC-D30/D30P

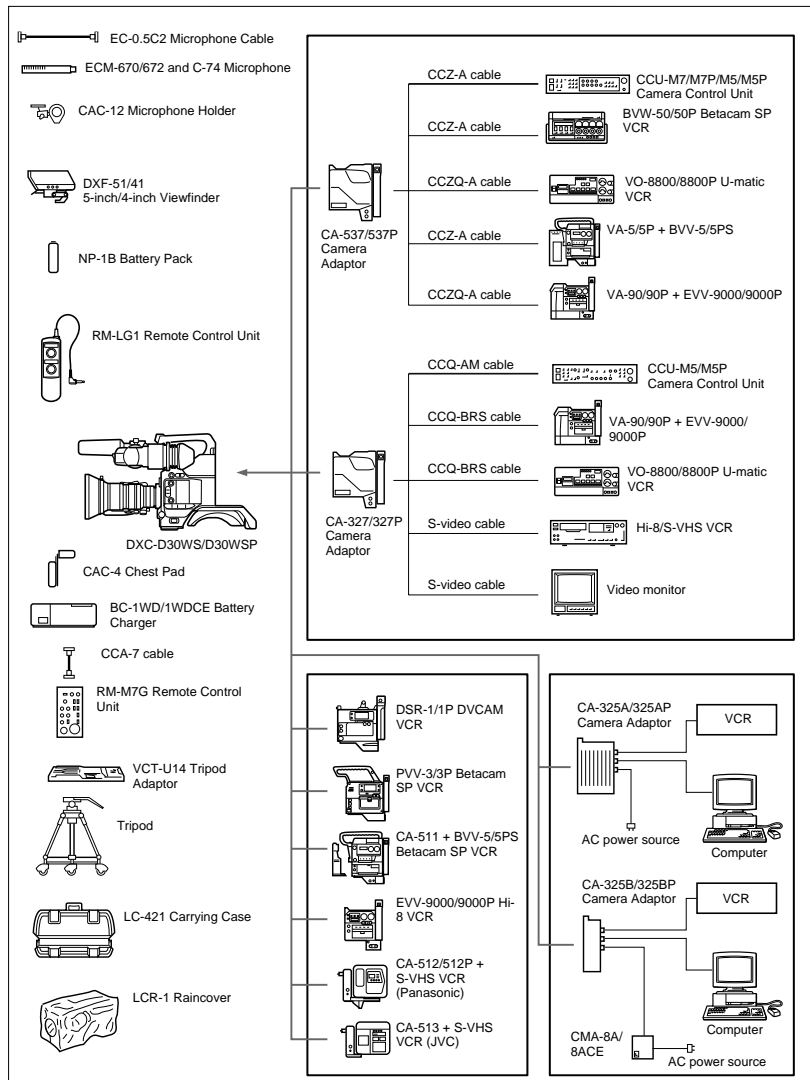

Color Video Camera

Operating Instructions

Before operating the unit, please read this manual thoroughly and retain it for future reference.

Power HAD

DXC-D30F/D30PF
DXC-D30K/D30PK
DXC-D30L/D30PL
DXC-D30H/D30PH

WARNING

To prevent fire or shock hazard, do not expose the unit to rain or moisture.

To avoid electrical shock, do not open the cabinet. Refer servicing to qualified personnel only.

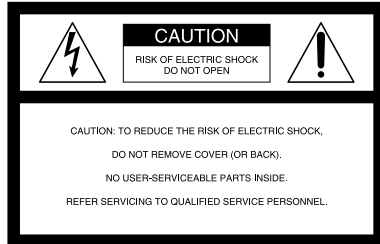

This symbol is intended to alert the user to the presence of uninsulated "dangerous voltage" within the product's enclosure that may be of sufficient magnitude to constitute a risk of electric shock to persons.



This symbol is intended to alert the user to the presence of important operating and maintenance (servicing) instructions in the literature accompanying the appliance.

Owner's Record

The model and serial numbers are located on the top. Record these numbers in the spaces provided below. Refer to them whenever you call upon your Sony dealer regarding this product.

Model No. _____ Serial No. _____

LITHIUM BATTERY

Replace the battery with a Sony CR2032 lithium battery. Use of another battery may present a risk of fire or explosion.

WARNING

Battery may explode if mistreated.
Do not recharge, disassemble or dispose of in fire.

Note

Keep the lithium battery out of the reach of children. Should the battery be swallowed, consult a doctor immediately.

ADVARSEL!

Lithiumbatteri - Eksplosjonsfare ved feilagtig håndtering. Udsiktning må kun ske med batteri af samme fabrikat og type.
Levér det brugte batteri tilbage til leverandøren.

ADVARSEL

Lithiumbatteri - Eksplosjonsfare.
Ved utskifting benyttes kun batteri som anbefalt av apparatfabrikanten.
Brukt batteri returneres apparatleverandøren.

WARNING

Explosionsfara vid felaktigt batteribyte.
Använd samma batterityp eller en likvärdig typ som rekommenderas av apparatillverkaren.
Kassera använt batteri enligt gällande föreskrifter.

VAROITUS

Paristo voi räjähtää jos se on virheellisesti asennettu. Vaihda paristo ainoastaan laitevalmistajan suosittelemaan tyyppiin.
Hävitätä käytetty paristo valmistajan ohjeiden mukaisesti.

For customers in the USA

This equipment has been tested and found to comply with the limits for a Class A digital device, pursuant to Part 15 of the FCC Rules. These limits are designed to provide reasonable protection against harmful interference when the equipment is operated in a commercial environment. This equipment generates, uses, and can radiate radio frequency energy and, if not installed and used in accordance with the instruction manual, may cause harmful interference to radio communications. Operation of this equipment in a residential area is likely to cause harmful interference in which case the user will be required to correct the interference at his own expense.

You are cautioned that any changes or modifications not expressly approved in this manual could void your authority to operate this equipment.

The shielded interface cable recommended in this manual must be used with this equipment in order to comply with the limits for a digital device pursuant to Subpart B of Part 15 of FCC Rules.

Table of Contents**Chapter 1****Overview**

Product Configurations	7
Features	8
Location and function of Parts	11
Camera Head	11
VCL-916BYA Zoom Lens	17
DXF-701/701CE Viewfinder	19

Chapter 2**Fitting and Connection**

Replacing the Lithium Battery	21
Fitting a VTR	22
Using the Camcorder Grip	23
Fitting the Lens	26
Using Accessories	28
Using the Viewfinder	28
Using an Optional Microphone	29
Fitting to a Tripod	31
Adjusting the Shoulder Pad Position	31
Using the Carrying Case	32
Connections	33
Connecting a Portable VTR	33
Connecting a Number of Cameras (Using a Camera Control Unit)	34
Connecting a Number of Cameras (Without Using a Camera Control Unit)	36
Power Supply	37
Using Battery Packs	37
Camera Adaptor Power Supply	38

Chapter 3**Shooting**

Basic Procedure for Shooting	39
Shooting with the DSR-1/1P	41
Using the ClipLink Function	41
Using the Edit Search Function While Back Space Editing	43
Using the Freeze Mix Function	44

Table of Contents

Chapter 4

Viewfinder Screen Indications and Menus

Viewfinder Screen Indications	45
Changing the Viewfinder Display	45
Viewfinder Normal Indications	47
Status Indications	50
Viewfinder Basic Menu	51
Basic Menu Operations	51
Contents and Settings of Each Page	51
Viewfinder Advanced Menu	57
Advanced Menu Operations	57
Contents and Settings of Each Page	57
Setup Files	62
Calling up a Setup File	62
Changing File Settings	64
Saving File Settings	64
Using SetupNavi and SetupLog with the DSR-1/1P	67
Setting up the camera Using Data Recorded on Tape	67
Recording the Menu Settings onto a Tape	68
Viewing SetupLog Data	69

Chapter 5

Adjustments and Settings

White Balance Adjustment	71
Saving an Appropriate White Balance Value in Memory	71
Using the Preset White Balance Settings	72
Light Sources and Color Temperatures	73
Using the ATW (Auto Tracing White Balance) Function	73
Black Balance Adjustment	74
Shutter Settings	75
Setting the Clock and Timestamping Recordings	77
Viewfinder Screen Adjustments	79
Adjusting the Lens	80
Flange Focal Length Adjustment	80
Iris Adjustments	81
Macrophotography	82

(Continued)

Chapter 5

Adjustments and Settings (Continued)

Settings for Special Cases	83
Skin Detail Correction	84
Adjusting Color in the Specified Area	84

Appendixes

Important Notes on Operation	85
Characteristics of CCD Sensors	85
Warning Indications	86
Specifications	87
Related Products	88
Chart of Optional Components and Accessories	90

Product Configurations

The eight models, DXC-D30F, DXC-D30K, DXC-D30L, DXC-D30H, DXC-D30PF, DXC-D30PK, DXC-D30PL, and DXC-D30PH, comprise both NTSC

and PAL versions and the components as shown in the figure below. The operation of the basic camera unit is the same in all cases.

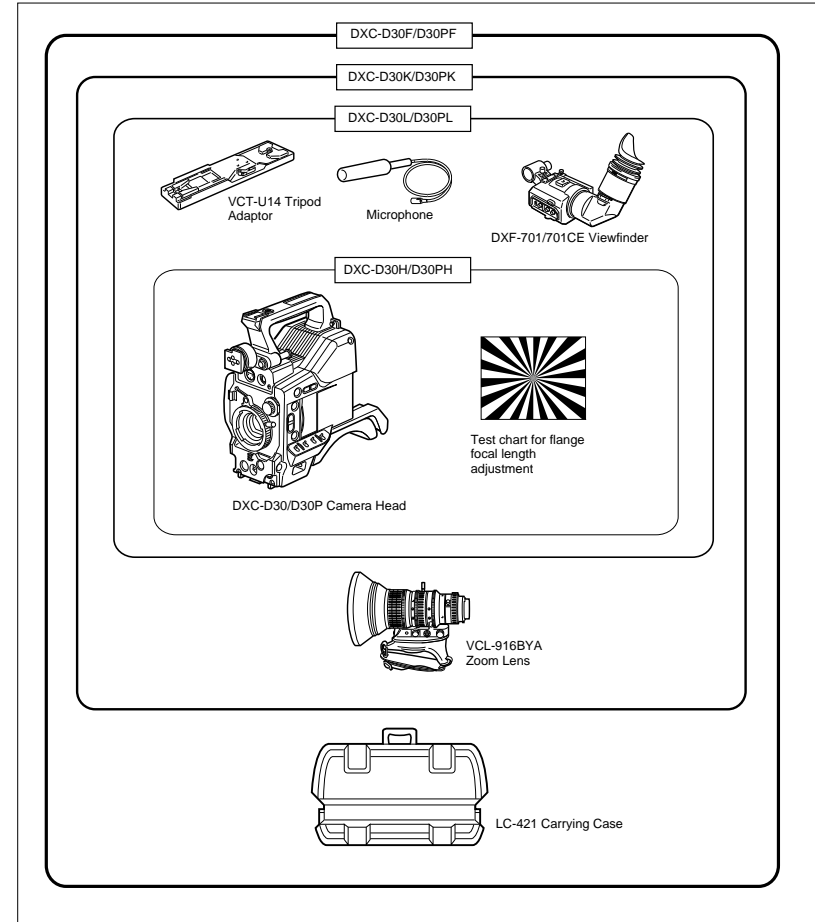

Camera adaptor

The product kit does not include a camera adaptor: to use a camera adaptor, you will need to purchase a model CA-537/537P or CA-327/327P.

Features

$\frac{2}{3}$ -inch IT type Power HAD CCD

The DXC-D30/D30P Color Video Camera uses $\frac{2}{3}$ -inch IT type Power HAD CCDs. It outperforms most of the exiting FIT type CCD cameras for high-end use, in both picture quality and sensitivity.

- Smear: -125 dB
- Sensitivity: F11.0 (at 3200 K, 2000 lux)
- S/N: 63 dB (DXC-D30) or 61 dB (DXC-D30P)

Sophisticated image processing

TruEye™ processing makes possible the following performance features. This new digital signal processing has brought reproduction of natural colors to the level achieved by the human eye.

DynaLatitude™

Enables detailed adjustment of contrast control in each pixel in accordance with a histogram of luminance signal levels.

DCC+ (dynamic contrast control plus)

Prevents white breakup when shooting a high intensity subject, and also prevents color faults in high intensity subject.

Black stretch and compress

Enables control of luminance signal levels in black areas without changing the hue.

Variety of detail corrections

- Skin detail function: this function gives a slightly softer appearance to the subject's face. The target skin color can be automatically set.
- Black halo correction
- Red/green vertical detail correction: this function performs vertical detail compensation for both red and green signals.
- Horizontal detail frequency control

Recording and managing setup data

In addition to the setup menu that is displayed in the viewfinder screen, the DXC-D30/D30P is equipped with the following functions to facilitate camera head setup.

Setup file system

You can use setup files when making adjustments or settings. The DXC-D30/D30P comes with factory preset files that contain shipped settings and you can freely create user files as well.

Automatic recording of setup data (when using DSR-1/1P)

When the DXC-D30/D30P is connected to the DSR-1/IP VTR, two types of setup data can be recorded.

SetupLog™: Shooting-related environment settings are recorded onto the tape at intervals of a few seconds. This recorded data can then be used to reproduce the same shooting conditions in subsequent shots. It also makes it easier to identify the causes of problems in previous shots.

SetupNavi™: The setup conditions selected with the setup menu and setup files are recorded onto the tape. The recorded setup data can be copied to other camera heads so that the same setup can be shared among several camera heads.

ClipLink™ Function (when using DSR-1/1P)

The ClipLink function can be used at every step from acquisition to editing. Information necessary for editing is recorded when shooting to ensure fast and efficient editing operations.

When you set a recording start (Rec IN) point or when you press the TAKE button to set a Mark IN point, the video image at that point is recorded on the tape in compressed form as an Index Picture. In addition, the time codes for such editing points (Mark IN/Mark OUT points or cue points) are recorded along with other editing point data (such as the cassette number and scene number) into cassette memory (as ClipLink log data). Unsuccessful scenes containing faults can also be marked in cassette memory as "NG", so that only the good scenes are taken up from cassette memory when editing.

Dockable with various types of VTRs

The DXC-D30/D30P docks with the DSR-1/1P DVCAM VTR to configure the DSR-130/130P digital camcorder. It also docks with the PVV-3/3P Betacam SP VTR to configure the PVW-D30/D30P Betacam SP camcorder. In addition, the DXC-D30/D30P docks with the EVV-9000/9000P Hi-8 VTR. Using an adaptor (not supplied), it is also able to dock with a variety of existing S-VHS VTRs.

New Functions boost operability

EZ (easy) mode function

When there isn't time to check the camera head settings, simply press the EZ mode button to start the auto adjustment function using standard settings. There is no need to lose a shot for lack of setup time.

EZ (easy) focus

Press the EZ focus button before shooting to ensure a quick and accurate focus.

Programmable gain

The amount of gain relative to the GAIN switch setting (H, M, or L) can be programmed as -3 dB, 0 dB, 3 dB, 6 dB, 9 dB, 12 dB, 18 dB, 18 dB+DPR¹⁾, 24 dB, 24 dB+DPR and hyper gain.

Hyper gain

Hyper gain (36 dB, or about 60 times greater than 0 dB) can be easily set via one switch setting. This can also be done from remote equipment.

Auto tracing white balance

This function automatically traces the white balance, which constantly changes as lighting conditions change. Auto tracing white balance is especially useful when there is no time to manually adjust the white balance or when shooting moves between indoor and outdoor locations.

Intensified auto iris control

In addition to the standard auto iris, the intelligent auto iris function adjusts the lens iris to compensate back lighting or spot lighting.

1) DPR = Dual Pixel Readout

Total level control system (TLCS)

Even if the incoming light exceeds the range in which the standard auto iris can control exposure, the auto gain control (AGC) or auto exposure (AE) backs up to ensure proper exposure.

Dual pixel readout (DPR)

When the gain is set to either 18 dB or 24 dB, the gain setting can be doubled (6 dB up) without increasing the noise level.

Recording time display

Recording time can be displayed in either of the following modes.

- Total recording time for all cuts
- Total recording time for current cut

Viewfinder super detail

Video signals for the viewfinder are mixed with V-DTL signals to make focusing easier.

Dual zebra pattern display

Two types of zebra patterns, zebra 1 and zebra 2 can be displayed simultaneously or independently. The zebra 1 can be set to the levels ranging from 70 to 90 IRE on the DXC-D30 (or from 70 to 90% on the DXC-D30P) and the zebra 2 indicates the levels of 100 IRE for the DXC-D30 or more (or the levels of 100% or more for the DXC-D30P).

Color temperature display

When reading the white balance, the color temperature is displayed on the viewfinder screen.

Video monitor output with text

The video signal with text superimposed that is shown in the viewfinder can also be output to an external video monitor.

Camera head microphone output indicator

An indication μ appears in the viewfinder whenever a signal is being output from the camera head's microphone.

1-kHz reference signal output

Along with a color bar, a 1-kHz reference signal can also be output.

Features

Freeze mix function (when using DSR-1/1P)

The freeze mix function superimposes any previously recorded still picture on the viewfinder screen to facilitate framing the subject when reshooting the scene.

Edit Search Function (when using DSR-1/1P)

When using the DXC-D30/D30P with the DSR-1/1P, pressing the EDIT SEARCH buttons allow the tape to play back in search mode. Set either of two playback speeds.

Designed for ease of operation

Adjustable shoulder pad

You can move the shoulder pad forward or backward to set a comfortable, well-balanced position.

Slide cover

The slide cover can hide the switches and buttons that are seldom used during shooting. The cover can be locked so as not to open during shooting.

High-performance viewfinder (DXF-701/701CE)

- High resolution (600 TV lines of horizontal resolution)
- Large-diameter eye cup for easier viewing and focusing
- PEAKING potentiometer for vertical and horizontal detail control
- Two indicators can be used as TALLY indicators
- Tough die-cast aluminum body

VTR data display

When connected to a VTR, the DXC-D30/D30P is able to display the following data on the viewfinder screen.

- Time values (counter, time code, or user bit vales)
- VTR audio levels
- Remaining tape time
- VTR operation mode
- Remaining battery capacity (when using an Anton Bauer Intelligent Battery System)
- ClipLink information (when using the DSR-1/1P)

Location and Function of Parts

Camera Head

Right side view

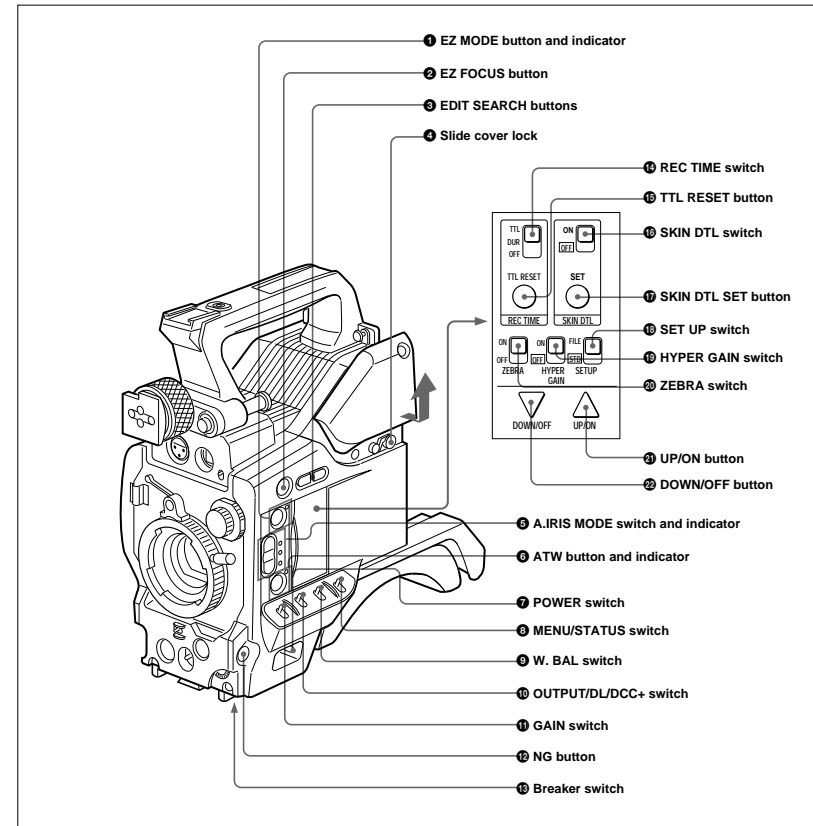

Location and Function of Parts

1 EZ (“easy”) MODE button and indicator

Depress this button (EZ mode on) when you want to be able to shoot immediately, with automatic adjustment of the camera settings to standard values. (See page 61.) When this function is used, the iris and the white balance are adjusted automatically. (The total level control system functions.) Press this button again to return the camera to the previous settings (EZ mode off).

Note

When connecting the CCU-M3/M5/M7 (or CCU-M3P/M5P/M7P) Camera Control Unit or the RM-M7G Remote Control Unit, the “easy mode” function is disabled.

2 EZ FOCUS button

Press this button to turn the “easy focus” function on. This opens the iris, to make it easier to focus before beginning shooting. The indication “EZ FOCUS” appears in the viewfinder while the function is on; to turn it off, press the EZ FOCUS button again. If left on, the function automatically turns off after about ten seconds.

Note

If the “easy focus” function is still on when you press the VTR button, it turns off automatically and recording starts about one second later.

3 EDIT SEARCH buttons (for operation with DSR-1/IP)

When using the DSR-1/IP to record, you can see the search playback while pressing either of these buttons at recording pause mode to quickly find the next recording start point. Two playback speeds are available, and press either of the buttons to the inner position to increase the speed.

4 Slide cover lock

This lock keeps the slide cover closed.

Pull the upper panel forward and then lift it up.

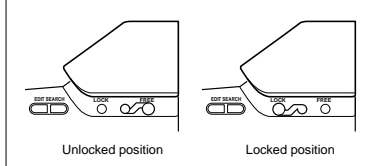

5 A.IRIS (auto iris) MODE switch and indicator

When you use the auto iris function (by setting the iris selector on the lens to A), set this switch to suit the shooting conditions. Selecting BACK L gives more light to back-lit subjects, and selecting SPOT L adjusts for high contrast in spot-lit subjects. For normal shooting, set this switch to STD.

6 ATW (auto tracing white balance) button and indicator

Press this button, turning the indicator on, when you want the white balance to be adjusted automatically to follow changes in lighting conditions. (See page 73.)

7 POWER switch

This powers the camera on and off. There are two different ON settings as follows.

ON STBY: This puts the VTR on standby. In this state, pressing the VTR button on the camera head, the lens or a camera adaptor starts recording immediately.

ON SAVE: This puts the VTR in the power-saving state, with the video head drum stationary. In this state, it takes a few seconds to start recording after pressing the VTR button.

Note

The VTR state when this switch is in the ON STBY or ON SAVE position may depend on the VTR model.

8 MENU/STATUS switch

When you press this switch to the MENU position, the basic menu is displayed. Keep pressing it to the MENU position to cycle through the various menu displays. When you press the switch to the STATUS position, the DXC-D30/D30P's status (of current settings) is displayed.

9 W. BAL (white balance) switch

This selects the white balance setting from the preset value, the value in memory A or the value in memory B. (See page 71.)

10 OUTPUT/DL/DCC+ (DynaLatitude/dynamic contrast control plus) switch

Use this switch to select the DCC+ function, the DynaLatitude function, or color bar output. Select the CAM/DCC+ position in most cases.

CAM/DCC+: This activates the DCC+ function. This prevents color faults when shooting high-intensity subjects.

CAM/DL: This setting uses the DynaLatitude function, which finely adjusts the contrast of each pixel according to a histogram of luminance signal levels. Access advanced menu page 2 to set the DynaLatitude function ON or OFF. The DynaLatitude effect can be set to any of three levels, Low, STD (standard), and High with basic menu page 3.

BARS: This setting displays color bars.

For details of menu operation, see Chapter 4 “Viewfinder Screen Displays and Menus”.

11 GAIN switch

This selects one of the three gain settings, high, medium or low. You can choose the gain values assigned to the H, M and L settings from values from -3 dB to 24 dB + DPR and hyper gain. (See page 57.) The factory default selections are 18 dB (H), 9 dB (M) and 0 dB (L).

Note

When the HYPER GAIN switch 19 is in the ON position, the GAIN switch has no effect.

12 NG button

When using the ClipLink function during shooting, you can designate a particular scene as “NG” (No Good) by pressing this button before shooting the next scene. Press the button again to cancel the NG setting.

13 Breaker switch

If there is a fault in the camera power supply, the breaker trips, and the camera power supply is disconnected. Correct the fault in the power supply, then press this switch.

14 REC (recording) TIME switch

This selects the recording time indication in the viewfinder.

TTL: Displays the total recording time.

The total recording time is not reset even when you stop the VTR and power off the camera, for example, to replace the battery pack.

DUR: Displays the recording time of the current cut.

OFF/TC: Switches off the recording time display. If, however, a PVV-3/3P is connected, and in the advanced menus you set the time code display item (TC IND) to ON (see page 59), then the VTR time data (time code, CTL count, or user bit value) is displayed.

Note

The recording time displayed when this switch is set to the TTL or DUR position is obtained by counting the duration of the internal reference signal input to the camera.

The value may not agree exactly with the value derived from the time code values. Furthermore, the value displayed may not be correct when another manufacturer's VTR is connected to the camera.

15 TTL (total) RESET button

Pressing this button resets the total recording time (TTL selection) to zero.

16 SKIN DTL (skin detail) switch

Set this switch to ON to use the skin detail correction function.

For details, see “Skin Detail Correction” (page 84).

17 SKIN DTL (skin detail set) SET button

Press this button with the SKIN DTL button 16 to display the area detect cursor on the viewfinder screen. Place the cursor on the target and press this button to perform skin detail correction.

For details, see “Skin Detail Correction” (page 84).

18 SET UP switch

Use this switch to select the camera head setup method.

STD: Set up using the setup menu. Setup file data is not displayed.

FILE: Set up using setup files and the setup menu.

19 HYPER GAIN switch

Setting this switch to the ON position increases the gain by a factor of about 60 with respect to 0 dB (a 30 dB increase by electronic amplification and a 6 dB increase for DPR, bringing about a total gain increase of 36 dB).

When this switch is in the ON position, the indication “HYPER” appears in the viewfinder, and the GAIN UP indicator in the viewfinder also lights.

When finished shooting, return this switch to the OFF position. The “HYPER” indication disappears and the GAIN UP indicator goes out.

Note

Increasing the gain with this switch reduces the horizontal resolution by 50%.

Location and Function of Parts

20 ZEBRA switch

Set this switch to the ON position to display a zebra pattern (diagonal stripes) in the viewfinder. Depending on the zebra setting in advanced menu page 4, the zebra 1 for video levels between 70 to 90 IRE (or 70 to 90%) and the zebra 2 for video levels 100 IRE or more (or 100% or more) can be displayed independently or simultaneously.

21 UP/ON button

Use this button to open displays and to make "ON" settings. When using the advanced menus, use this button to change menu pages or to switch to the ordinary screen display.

22 DOWN/OFF button

Use this button to close displays and to make "OFF" settings. You can also use this button to change menu pages when using the advanced menus.

Front view

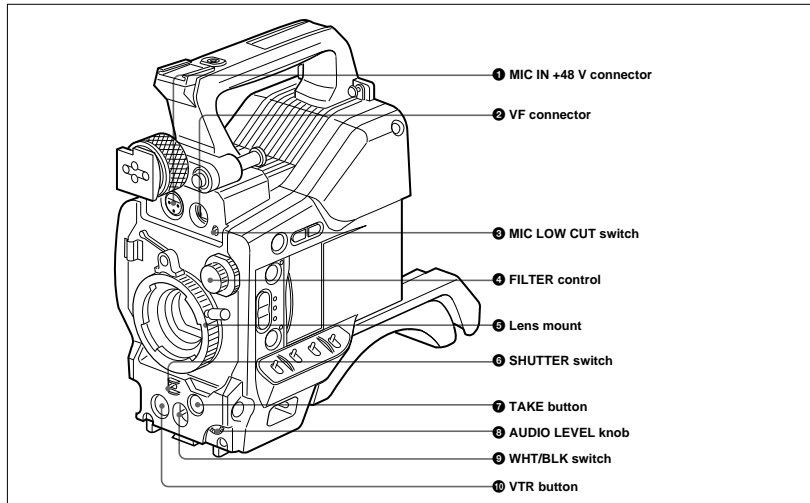

1 MIC (microphone) IN +48 V connector (XLR 3-pin, female)

Connect the supplied microphone or an optional microphone (operable with a 48 V supply).

2 VF (viewfinder) connector (20-pin)

This is the connector for the DXF-701/701CE viewfinder.

Note

When using this connector, do not connect a DXF-40B/50B (or DXF-40BCE/50BCE) viewfinder to the VF connector on the left side.

3 MIC LOW CUT switch

Set this switch to the ON position to insert a high-pass filter in the microphone circuit, reducing wind noise. Normally leave the switch in the OFF position.

4 FILTER control

Select the color temperature conversion filter appropriate to the lighting conditions. (See page 39.)

5 Lens mount

Attach the zoom lens here.

6 SHUTTER switch

7 TAKE button

8 AUDIO LEVEL knob

9 WHT/BLK switch

10 VTR button

6 SHUTTER switch

Use this switch to set the shutter speed, CLS (clear scan), or EVS setting (see page 75). Usually, set this switch to OFF.

7 TAKE button

Press this button to specify an editing point (Mark IN/OUT or cue point) at the current tape position during shooting.

8 AUDIO LEVEL knob

When the DSR-1/IP is attached, you can use this knob to manually adjust the channel 1 audio recording level.

9 WHT/BLK (white/black) switch

This switch is used for automatic adjustment of the white balance and black balance. (See pages 71 to 74.)

10 VTR button

Pressing this button starts and stops recording on the VTR.

Left and upper view

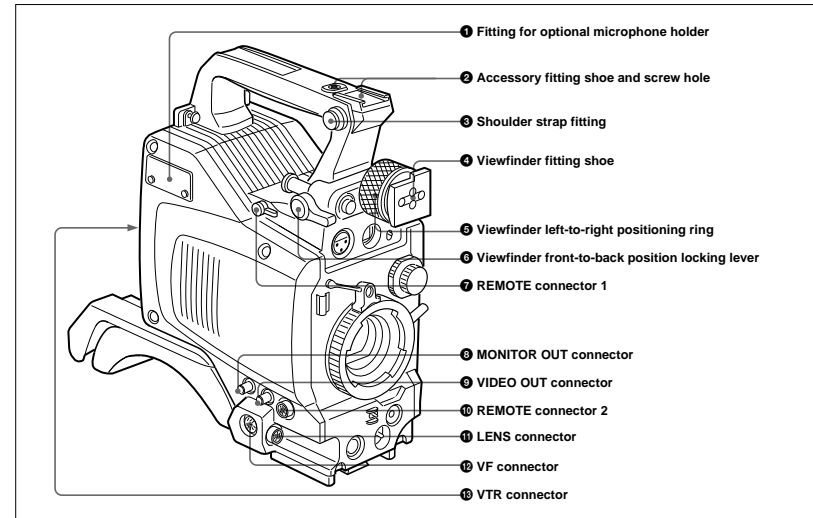

1 Fitting for optional microphone holder

You can fit an optional CAC-12 Microphone Holder here. (See page 29.)

2 Accessory fitting shoe and screw hole

Attach optional video lights or other accessories here.

3 Shoulder strap fixture

To use the supplied shoulder strap, fix one end here and the other end to the VTR.

1 Fitting for optional microphone holder

2 Accessory fitting shoe and screw hole

3 Shoulder strap fitting

4 Viewfinder fitting shoe

5 Viewfinder left-to-right positioning ring

6 Viewfinder front-to-back position locking lever

7 REMOTE connector 1

8 MONITOR OUT connector

9 VIDEO OUT connector

10 REMOTE connector 2

11 LENS connector

12 VF connector

13 VTR connector

4 Viewfinder fitting shoe

Fix the DXF-701/701CE Viewfinder here.

5 Viewfinder left-to-right position fixing ring

Loosen this ring to adjust the left-to-right position of the viewfinder. (See page 28.)

6 Viewfinder front-to-back position locking catch

Release this catch to adjust the front-to-back position of the viewfinder. (See page 28.)

Location and Function of Parts

7 REMOTE connector 1 (mini-jack)

Use this connector to connect the switch for enabling remote operation of the ClipLink function.

For details of connectable switches, contact your Sony dealer.

8 MONITOR OUT connector (BNC)

Outputs both the camera video and the character information as displayed on the viewfinder screen. You can connect an optional LCD color monitor to this connector.

9 VIDEO OUT connector (BNC)

This outputs the video signal captured by the camera.

10 REMOTE connector 2 (10-pin)

Connect the optional RM-M7G Remote Control Unit to this connector. Set the CAMERA HEAD SELECT switch on the bottom of RM-M7G to 1.

Notes

When using the RM-M7G, note the following points.

- When operating the camera head from the camera control unit, connect the RM-M7G to the camera control unit.
- EZ mode cannot be used if the RM-M7G is connected to the camera head.

11 LENS connector (12-pin, for 2/3-inch lens)

Connect the lens connector.

12 VF (viewfinder)connector (8-pin)

This is the connector for the DXF-40B/50B (or DXF-40BCE/50BCE) viewfinder.

Note

When using this connector, do not connect a DXF-701/701CE viewfinder to the VF connector on the front of the camera head.

13 VTR connectors (PRO 76-pin DIGITAL and PRO 50-pin)

Connect a dockable VTR. A PRO 76-pin DIGITAL connector is for the DSR-1/1P and a PRO 50-pin connector is for the PVV-3/3P or a camera adaptor.

VCL-916BYA Zoom Lens

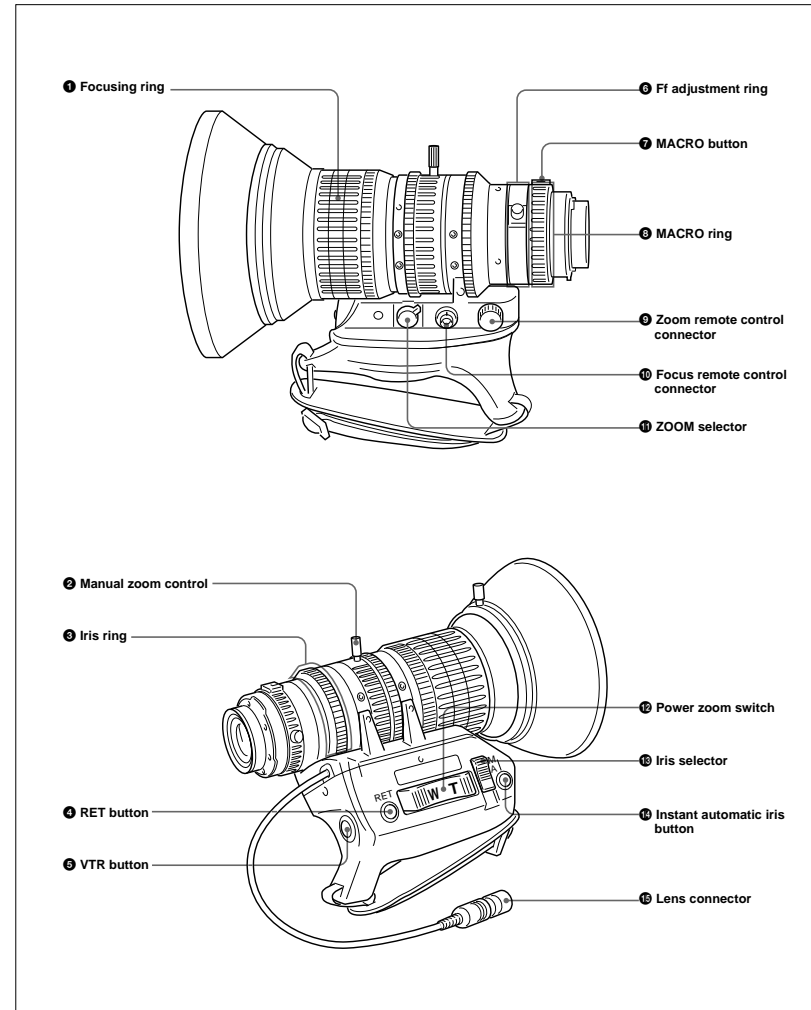

Location and Function of Parts

1 Focusing ring

Turn this ring to focus the lens on the subject.

2 Manual zoom control

For direct manual zoom control, set the ZOOM selector to the “M” position, and turn this control.

3 Iris ring

For manual iris control, set the iris selector to the “M” position, and turn this control.

4 RET (return) button

This allows you to check the video signal as follows.

When operating with a portable VTR connected via other equipment: when the VTR is recording, pressing this button connects the E-E video signal¹⁾ from the VTR to the viewfinder.

When operating with a DSR-1/IP or PVV-3/3P mounted on the camera head: when the VTR is in recording pause mode, press this button to review the last few seconds of the recording in the viewfinder (recording review).

When operating with a CCU-M3/M3P/M5/M5P M7/M7P Camera Control Unit connected: pressing this button connects the return video signal from the camera control unit to the viewfinder.

When this button is not pressed, the viewfinder displays the video signal captured by the camera.

5 VTR button

When operating with a VTR: this button starts and stops recording on the VTR. Press it once to start recording, and once more to stop.

When operating with a CCU-M3/M3P/M5/M5P M7/M7P Camera Control Unit connected: pressing this button connects the return video signal from the camera control unit to the viewfinder. (Starting and stopping recording is controlled on the VTR.)

6 Ff (flange focal length) adjustment ring

To adjust the flange focal length, loosen the screw on this ring, then turn the ring. (See page 80.)

1) E-E video signal: “electric-to-electric” video signal.

This is an output from the VTR of the input video signal which has passed through internal electrical circuits, but has not been converted to a magnetic signal in the heads or on the tape.

7 MACRO button

For close-up work, hold this button down while turning the MACRO ring. (See page 82.)

8 MACRO ring

For close-up work, hold the MACRO button down while turning this ring. (See page 82.)

9 Zoom remote control connector (8-pin)

For remote control of zoom operations, connect an optional LO-23 Lens Remote Control Unit.

10 Focus remote control connector (3-pin)

This is not used.

11 ZOOM selector

This selects the mode of zoom operation.

S (servo): power zoom
M (manual): manual zoom

12 Power zoom switch

Use this to carry out a power zoom.

W end: zoom toward wide angle
T end: zoom toward telephoto
Pressing the switch harder increases the zoom speed.

13 Iris selector

This selects the mode of iris operation. (See page 81.)

A (automatic): automatic iris
M (manual): manual iris

14 Instant automatic iris button

While using manual iris control, press this button to switch temporarily to the automatic iris control setting. The automatic setting is maintained as long as you hold the button down.

15 Lens connector

Connect this to the LENS connector on the camera head.

DXF-701/701CE Viewfinder

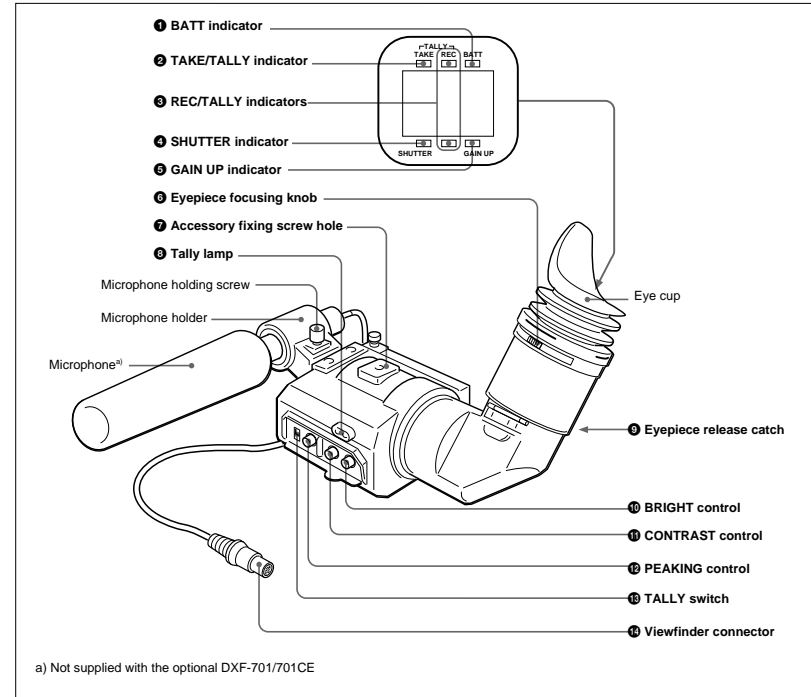

1 BATT (battery) indicator (red)

This indicates when the battery capacity is low. (See page 37.)

Note

When using a camera control unit, this indicator flashes when you operate the controls, but this is not a malfunction.

2 TAKE/TALLY indicator (orange)

When using the ClipLink function while shooting, this indicator lights when the TAKE button has been pressed to set a Mark IN point and goes out when a Mark OUT point is set.

3 REC/TALLY (recording/tally) indicators (red)

- From the time when you press the VTR button on the lens or camera head, this flashes until recording starts, then stays on continuously during recording.
- When using a camera control unit, this lights when the video from this camera is selected.
- This is also used to indicate a fault. (See page 86.)
- The lower indicator can be disabled by menu setting. (See page 58.)

4 SHUTTER indicator (red)

This lights when the SHUTTER switch is in the ON position. (If the EVS is selected, the indicator will not light.)

Location and Function of Parts

5 GAIN UP indicator (orange)

This lights when the gain is 3 dB or more.

6 Eyepiece focusing knob

Turn this to adjust the viewfinder focus to match your eyesight. (See page 79.)

7 Accessory fixing screw hole

Attach optional video lights or other accessories here.

8 Tally lamp

When the TALLY switch is in the ON position, this operates in the same way as the REC/TALLY indicators 3.

9 Eyepiece release catch

To view the viewfinder screen directly, press this catch, and hinge up the eyepiece.

10 BRIGHT (brightness) control

This adjusts the brightness of the viewfinder image. (See page 79.)

11 CONTRAST control

This adjusts the contrast of the viewfinder image. (See page 79.)

12 PEAKING control

This adjusts the outline intensity of the viewfinder image. (See page 79.)

13 TALLY switch

Set this switch to the ON position to use the tally lamp 8.

14 Viewfinder connector (20-pin)

Connect this to the VF connector (front) on the camera head.

Replacing the Lithium Battery

The camera head uses a lithium battery (CR2032) to retain date and time data. When the lithium battery's voltage falls, the clock indication does not appear. Replace the lithium battery and set the clock (see page 77).

Note

- Carefully read the instructions for replacing the lithium battery. Lithium batteries may explode if misused.
- Use only CR2032-type lithium batteries. Other types of lithium batteries may come loose when the camcorder is moved. If you have difficulty finding CR2032-type lithium batteries, contact your Sony dealer.

- 1 Pull the upper part of the battery cover (on the rear of the camera head) forward and turn the cover clockwise.

For detaching the VTR or camera adaptor, see "Fitting a VTR" next page.

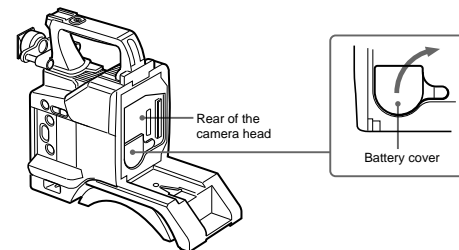

- 2 Take out the lithium battery.

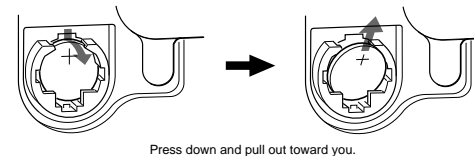

- 3 Reverse step 2 to insert a replacement lithium battery. Make sure that the + symbol on the battery is facing you.

- 4 Close the battery cover.

Fitting a VTR

This section explains how to attach the DSR-1/1P to the camera head. The method for attaching a PVV-3/3P is similar.

When replacing the camera head grip with a camcorder grip, see "Using the Camcorder Grip" (page 23).

- 1 Set the PRO 76-pin DIGITAL connector on the DSR-1/1P.

For details, see the operating instructions for the DSR-1/1P.

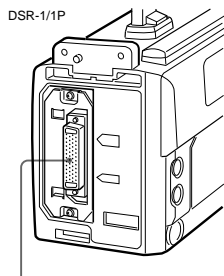

Camera connector (PRO 76-pin DIGITAL)

- 2 Align the projection on the bottom of the DSR-1/1P with the slot on the camera head.

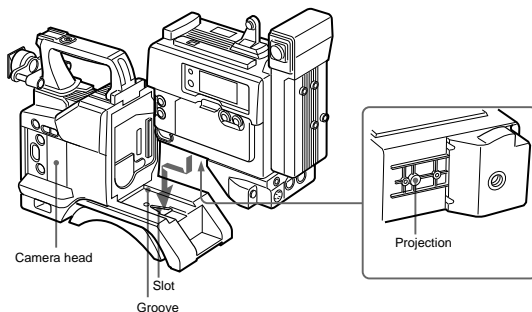

- 3 Slide the DSR-1/1P and the camera head together in the groove as far as possible.

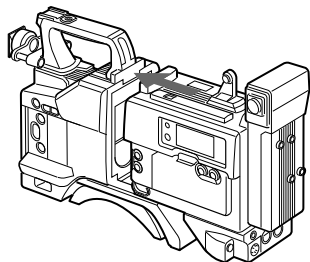

(continued)

- 4 Tighten the two screws in the grip connector and the two screws in the shoulder pad section.

Note

Slide the shoulder pad to its central position before tightening the screws. Otherwise the screws may not be properly fixed.

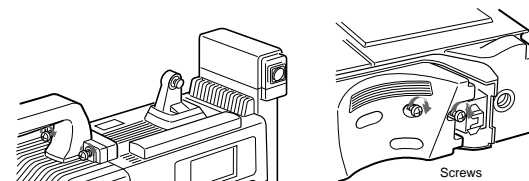

To remove the VTR

Reverse the fitting procedure.

To fit a camera adaptor

Follow the same procedure as when fitting a VTR.

Using the Camcorder Grip

When using the camera head with a VTR as a camcorder, you can replace the camera head's grip with a camcorder grip (not supplied). The type of

camcorder grip and the method for attaching it differ slightly depending on the type of VTR.

Attaching a camcorder grip to the DSR-1/1P

- 1 If the viewfinder is attached, adjust the viewfinder to the full-forward position.

For details, see "Adjusting the viewfinder position" on page 28.

- 2 Remove the camera head grip's three screws, then pull up the grip to remove it.

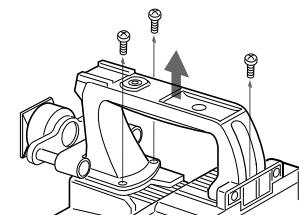

(continued)

Fitting a VTR

- 3** Remove the VTR connection plate.

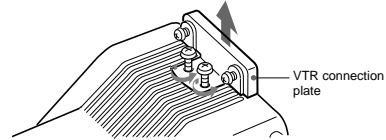

- 4** Remove the DSR-1/1P's shoulder strap fitting and the camera head connection plate.

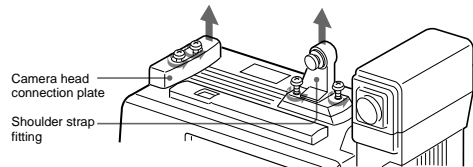

- 5** Perform the first three steps in "Fitting a VTR".

- 6** Screw the connection plate (supplied with the grip for the DSR-130/130P) which straddles the connection between the camera head and the DSR-1/1P. Also, tighten the two screws in the shoulder pad section. (See step 4 on page 23.)

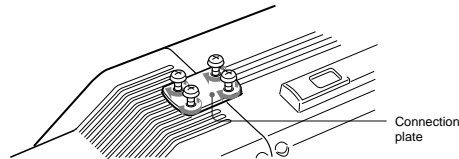

- 7** Screw the grip for the DSR-130/130P.

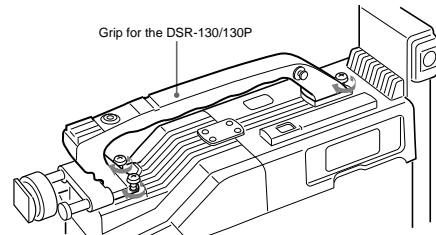

Attaching a camcorder grip to the PVV-3/3P

- 1** Perform steps 2 to 4 in "Fitting a VTR".

- 2** If the viewfinder is attached, adjust the viewfinder to the full-forward position.

For details, see "Adjusting the viewfinder position" on page 28.

- 3** Remove the grip's three screws, then pull up the grip to remove it.

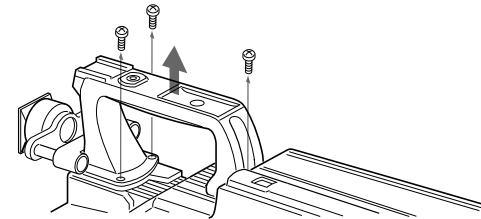

- 4** Remove the PVV-3/3P's shoulder strap fitting.

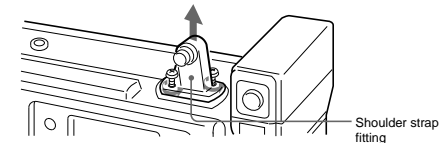

- 5** Screw the grip for the PVW-D30/D30P.

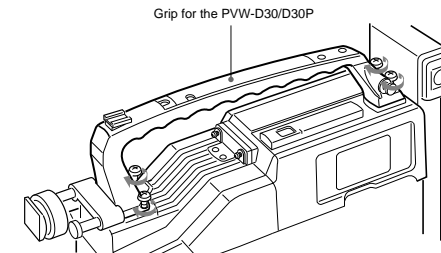

Fitting the Lens

In the case of the DXC-D30F/D30PF/D30K/D30PK model, the lens is already fitted. In other cases, use the following procedure to fit the lens.

- 1 Remove the retaining rubber which prevents the lens mount from coming loose, then raise the lens fixing lever, and remove the lens mount cap.

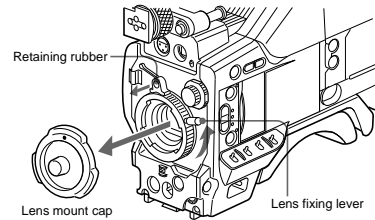

- 2 With the lens fixing lever turned fully counterclockwise, push in the lens, aligning the projection on the lens with the cutout on the camera.

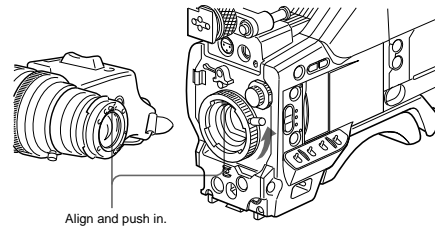

- 3 Supporting the lens, turn the lens fixing lever fully clockwise. Replace the retaining rubber on the lens mount.

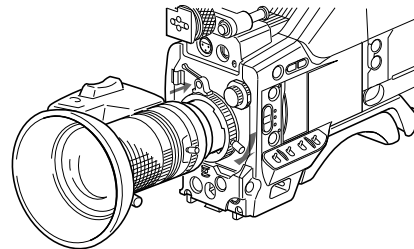

- 4 Using the triangular mark as a guide, push the lens connector into the LENS connector on the camera head, until it clicks into place. Fasten the cable with the clamps.

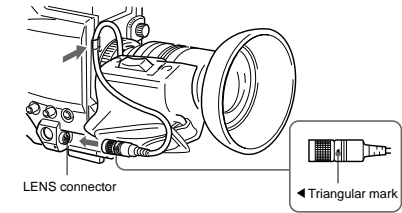

If using a lens with a 6-pin connector

This camera head has a 12-pin LENS connector. If the lens cable has a 6-pin connector, fit an adaptor cable: LO-612 (manufactured by Canon) or ECF-124 (manufactured by Fujinon) or equivalent.

Fitting optional filters

Loosen the lens hood fixing screw to remove the lens hood, then attach the filter.

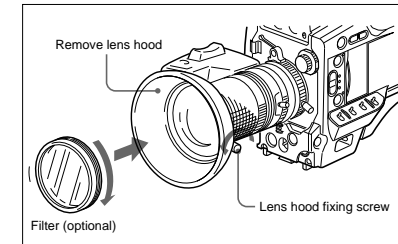

Using Accessories

Using the Viewfinder

Removing the Viewfinder

Remove any microphone from the viewfinder before beginning.

- 1 Pull the viewfinder connector out of the VF connector on the front of the camera head.

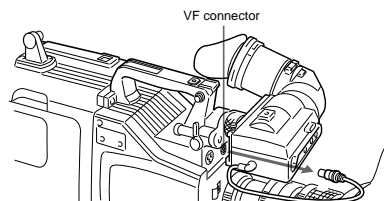

- 2 Loosen the viewfinder left-to-right position fixing ring, then pulling up the retaining catch, slide the viewfinder out.

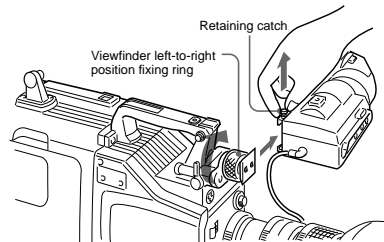

To fit the viewfinder

Reverse the removal procedure.

Adjusting the viewfinder position

To adjust the viewfinder left-to-right position, loosen the left-to-right fixing ring, and to adjust the front-to-back position loosen the front-to-back position locking catch.

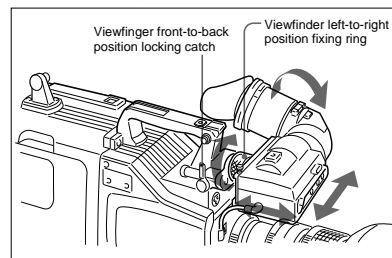

Left eye adaptor

By fitting a left eye adaptor, you can use the camera with your left eye to the viewfinder.

Note

You cannot stow the camera attached with a left eye adaptor in the LC-421 Carrying Case.

For details, consult your Sony dealer.

Using an Optional Microphone

To use a long microphone such as the optional ECM-670/672, remove the supplied microphone holder, and fit an optional CAC-12 Microphone Holder to the camera, then mount the microphone in this holder.

Removing the supplied microphone holder

Remove the two microphone holder retaining screws (M4 × 6) from the viewfinder, remove the microphone holder, then replace the screws in their original positions.

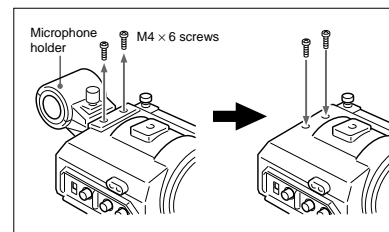

Fitting the optional CAC-12 Microphone Holder

Remove the two retaining screws (M3 × 8) for the optional microphone holder, then use these screws to attach the CAC-12 Microphone Holder.

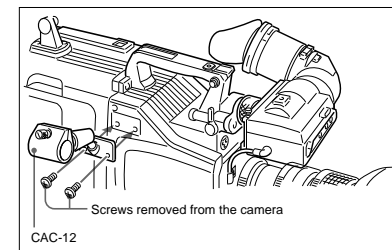

Using Accessories

Fitting an optional microphone

Use the following procedure to attach an optional ECM-670 Microphone.

- 1 Loosen the screw of the CAC-12 Microphone Holder, then open the holder and replace the microphone adaptor with the one supplied with the ECM-670 Microphone.

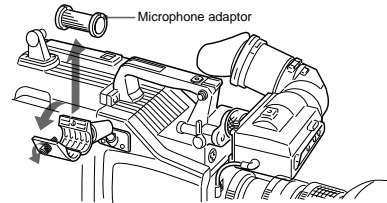

- 2 Insert the microphone in the microphone holder, close the holder, and tighten the screw. Connect the microphone cable to the MIC IN +48 V connector.

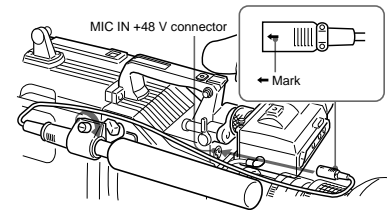

Fitting optional microphones (operable with a 48 V supply) other than the ECM-670

Use the same fitting procedure as for the ECM-670, but note the following differences with respect to the microphone adaptor.

- ECM-672:** no microphone adaptor required.
- Slender microphones (19 mm (3/4 inch) diameter):** use the microphone adaptor supplied with the CAC-12.

Fitting to a Tripod

First fit the VCT-U14 Tripod Adaptor to the tripod, then mount the camera on the tripod adaptor.

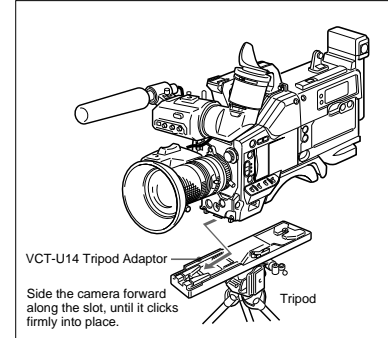

Removal

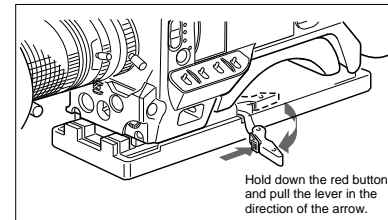

Note

After removing the camera, if the tripod adaptor pin has not returned to its original position, hold down the red button and move the lever in the direction of the arrow to return the pin to its original position. It is not possible to mount a camera with the pin left out.

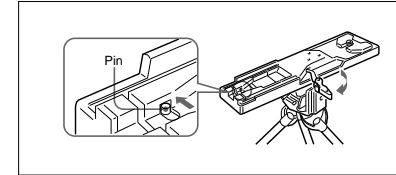

Adjusting the Shoulder Pad Position

You can slide the shoulder pad toward the front or back by up to 10 mm from its central position (as when shipped). Adjust it to get the best balance when using the camera on your shoulder.

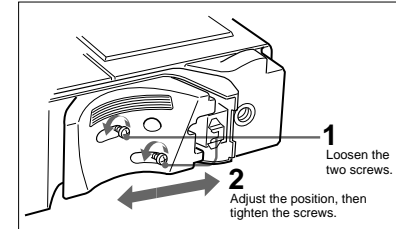

Optional CAC-4 Chest Pad

When using the camera on your shoulder, attaching the optional CAC-4 Chest Pad reduces the load on your right hand supporting the zoom lens, and makes operation easier.

For details see the instructions provided with the CAC-4.

Using Accessories

Using the Carrying Case

Stowing the camera

Align the camera with the base of the case, and slide the camera in forward.

Checking that the pin at the rear engages correctly, push forward until it locks into place.

Notes

- Bring the viewfinder into the horizontal position, slide it fully rearward and to the left, then fix before stowing.
- When an optional microphone (ECM-670/672, C-74, etc.) is attached, loosen the microphone fixing screws, move the microphone to the lowest position, and fix before stowing.

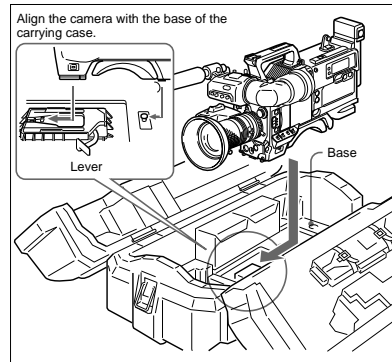

Example of fully-stowed carrying case

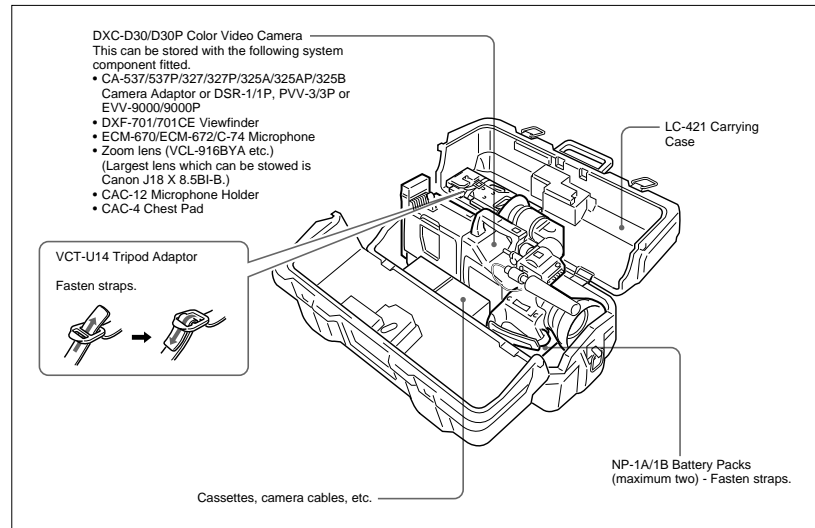

Connections

Connecting a Portable VTR

Using the optional CA-537/537P or CA-327/327P Camera Adaptor and a camera cable, you can connect a portable VTR. Set the VTR selector switch on the camera adaptor according to the VTR connected.

If using a VTR from another manufacturer, consult your Sony dealer.

Checks before making connections

Check first that the video camera, camera adaptor, VTR, and other devices are all powered off.

Making connections

Using a camera cable, connect the VTR/CCU/CMA connector on the camera adaptor to the camera input connector of the VTR.

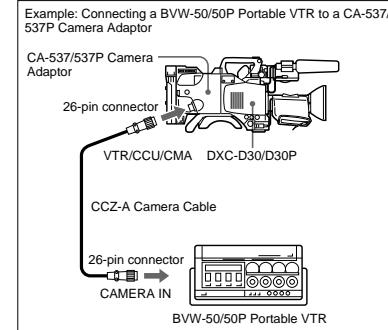

Camera cable

- Select a camera cable to fit the camera input connector on the VTR you are using.
- The maximum camera cable extent is 10 m (33 ft).

For details, consult your Sony dealer.

Video monitor

- If using an S-VHS VTR, using a video monitor with an S-video input connector and connecting it to the S-video connector of the VTR will allow you to monitor a clear picture, with no flecking.
- The output video signal from the VIDEO OUT connector of this unit is a composite video signal. Connect the VIDEO OUT connector of this unit to a composite video signal input connector of the monitor.

Setting the VTR selector switch on the camera adaptor

When using the camera with a CA-537/537P/327/327P Camera Adaptor, it is essential to correctly set the VTR selector switch on the camera adaptor according to the VTR connected. This switch determines the type of video signal output from the VTR/CCU/CMA connector and the audio output signal level.

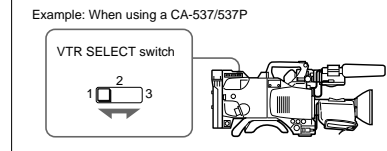

Connections

VTR selector settings on the CA-537/537P

Connected VTR	VTR selector switch setting	Video output signal	Audio output signal level
Sony broadcast and professional VTRs: BVU-150/150P, VO-6800/6800PS ^{a)} , BVW-50/50P and BVV-5/5PS ^{a)}	1	Composite (BVU-150/150P and VO-6800/6800PS) or component (BVW-50/50P and BVV-5/5PS)	-60 dB
Sony professional VTRs: VO-8800/8800P and EVV-9000/9000P	3	Y/C	-60 dB
Panasonic AG-6400 VHS VTR	2	Composite	-20 dB
Panasonic AG-7400 S-VHS VTR ^{b)} and JVC BR-S405 S-VHS VTR	3	Y/C	-20 dB

- a) Set the audio input level on the VO-6800/6800PS to -60 dB.
- b) When the BVV-5/5PS is used as a portable VTR, a VA-5/5P VTR Composite/Component Adaptor is required.
- c) Set the input selector switch on the AG-7400 to Y/C.

VTR selector settings on the CA-327/327P

Connected VTR	VTR selector switch setting	Video output signal	Audio output signal level
Sony broadcast and professional VTRs: BVU-150/150P and VO-6800/6800PS ^{a)}	1	Composite	-60 dB
Sony professional VTRs: VO-8800/8800P and EVV-9000/9000P	3	Y/C	-60 dB
Panasonic AG-6400 VHS VTR	2	Composite	-20 dB
Panasonic AG-7400 S-VHS VTR ^{b)}	4	Y/C	-20 dB

- a) Set the audio input level on the VO-6800/6800PS to -60 dB.
- b) Set the input selector switch on the AG-7400 to Y/C.

Connecting a Number of Cameras (Using a Camera Control Unit)

When using a number of cameras in the studio, it may be necessary to use a CCU-M5/M5P/M7/M7P Camera Control Unit to provide video and color sync between cameras, and special effects and other devices to allow switching, wipes and so forth. In the studio it may also be convenient to use a DXF-40B/40BCE/50B/50BCE Viewfinder.

The figure in the next page shows an example studio configuration.

For details, consult your Sony dealer.

Notes

- When using the CCU-M5/M5P, put the camera head into the EZ mode off state beforehand (see page 12). (Otherwise, it may be impossible to access the advanced menu.)
- With the DXC-D30/D30P, color matrix switching on the CCU-M5/M5P is invalid.
- When the DL in advanced menu page 2 is set to ON (see page 57) and the OUTPUT/DL/DCC+ switch is set to DL, knee adjustment does not function on the CCU-M7/M7P.

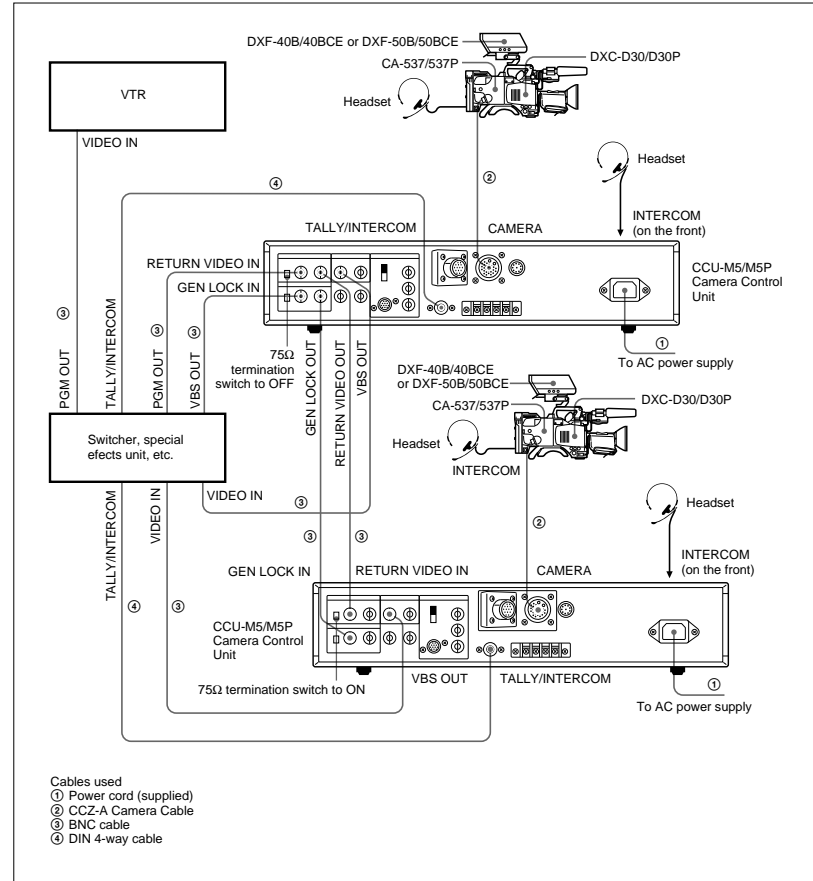

- Cables used
- ① Power cord (supplied)
 - ② CCZ-A Camera Cable
 - ③ BNC cable
 - ④ DIN 4-way cable

Connections

Connecting a Number of Cameras (Without Using a Camera Control Unit)

When using two or more synchronized cameras without a camera control unit, connect an external sync signal to the GEN LOCK IN connector on the camera adaptor (CA-537/537P etc.), supplying a VBS or BS

signal. The camera will then operate synchronized to this signal. You can adjust the synchronization using the basic menu. (See page 53.)

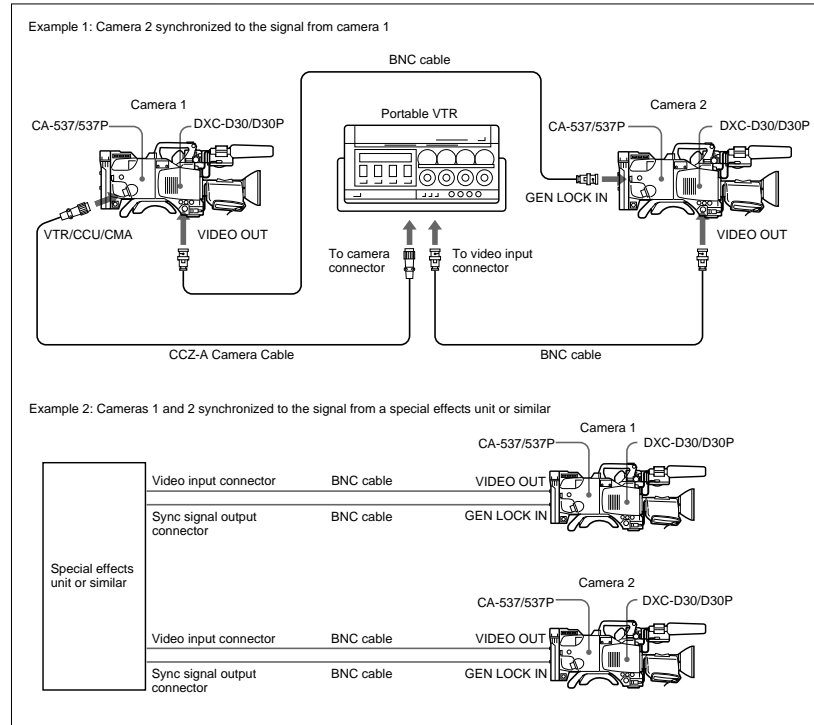

Power Supply

This unit operates on either a battery pack or an AC supply (using the optional CMA-8A/8ACE AC Adaptor).

For details of the power supplies which can be used, refer to the documentation supplied with the VTR connected to this unit or the camera adaptor.

Using an Anton Bauer Intelligent Battery System and Ultralight System

Fitting the special battery mount made by Anton Bauer Corporation to this unit allows you to use their Intelligent Battery System and Ultralight System.

For details, consult your Anton Bauer products supplier or Sony dealer.

Using Battery Packs

Always fully charge a battery pack before using it.

Notes

- Be careful that other metal objects do not come in contact with the metal parts of the battery pack, as this could cause a short.
- Do not leave the battery pack in the camera if it is not going to be used for a long time.
- If the battery pack is recharged after use while still hot, it may not be possible to obtain a full charge.

Fitting a battery pack (NP-1B)

Open the lid of the battery case, insert a fully-charged battery pack, and close the lid.

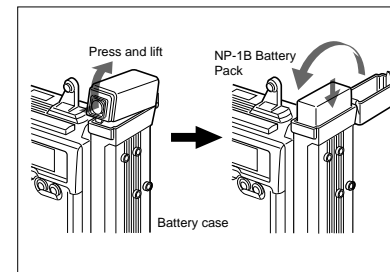

Battery pack operating times

The following table shows approximate continuous operating times, when operating the camera and 1.5-inch viewfinder at normal temperatures, with a camera adaptor and an DSR-1/1P or PVV-3/3P connected.

Approximate operating times with a fully-charged battery pack

Battery pack	With camera adaptor	With DSR-1/1P	With PVV-3/3P
NP-1B	110 minutes	60 minutes	60 minutes
NP-1A	85 minutes	45 minutes	50 minutes
BP-90A ^{a)}	—	130 minutes	140 minutes

a) Requires the special-purpose DC-500 Battery Case. Cannot be used with a camera adaptor.

Battery low indications

When the voltage of the supply to the camera head lowers to or below 11.0 V, the battery voltage indication appears in the viewfinder. At this time, the BATT indicator in the viewfinder flashes when operating with the DSR-1/1P or PVV-3/3P. If you continue using the camera head, the BATT indicator lights up. When the battery pack is low, replace it with a fully-charged battery pack.

Battery pack charging

Before using a battery pack, charge it as shown in the following table.

Battery pack	Battery charger	Approximate charging time (normal temperature)
NP-1A	BC-1WD/1WDCE, BC-410/410CE	70 minutes
NP-1B	BC-1WD/1WDCE, BC-410/410CE	95 minutes
BP-90A	BC-410/410CE	160 minutes

For details of battery charger operation, refer to the instructions provided with the battery charger to be used.

Power Supply

Camera Adaptor Power Supply

The camera adaptor automatically operates on power supplied to the VTR/CCU/CMA connector from the portable VTR, CCU-M7/M7P Camera Control Unit, CMA-8A/8ACE AC Adaptor or other connected device.

Note

Before use, check that the device connected to the VTR/CCU/CMA connector is able to provide the power required by the camera. If it is not able to provide the necessary power, or when it is necessary to prolong the operating time, use the camera with a separate power supply.

Basic Procedure for Shooting

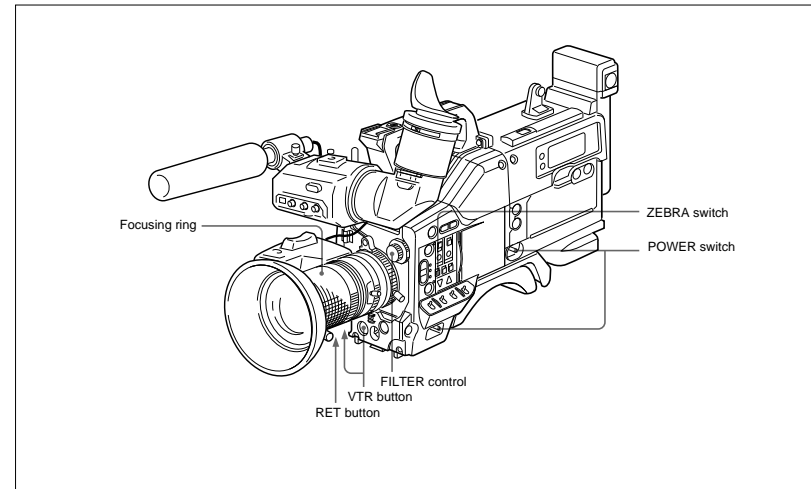

- 1 Attach the VTR or camera adaptor to the camera head, then turn each device's power on.
- 2 Set the FILTER control appropriately for the lighting conditions.
- 3 Check the switch settings on the camera head. (See pages 11 to 15.)
If there is not sufficient time to check the camera settings, you can use "easy mode" by setting the EZ MODE switch to the ON position. The camera is automatically adjusted to standard settings, and the iris and the white balance are adjusted automatically. (See page 61.)
- 4 Check the settings in the basic menu (page 51) and advanced menu (page 57).
- 5 Check the lens settings (pages 26 and 27) and flange focal length adjustment (page 80).
- 6 Adjust the eyepiece focus, and the contrast and brightness of the viewfinder image (page 79).
- 7 Check the sound system settings.
 - Microphone connections
 - Settings on the VTR (refer to the VTR instructions)

(continued)

- 1) **Hunting:** This occurs if the automatic iris function is not able to reach a stable state, and as a result the image brightness keeps changing, alternately lighter and darker.
- 2) **Depth of field:** This is the range over which the subject is sharply in focus.

Filter setting	Lighting conditions
1 (3200K)	Studio halogen lighting (incandescent), sunrise and sunset.
2 (5600K + 1/8 ND)	Sunlight. This setting includes a 1/8 neutral density filter (reducing the exposure by the equivalent of three stops). Use it to prevent hunting ¹⁾ or to reduce the depth of field ²⁾ .
3 (5600K)	Cloudy or rainy outdoor shooting, and fluorescent lighting.
4 (5600K + 1/16 ND)	Sunlight. This setting includes a 1/16 neutral density filter (reducing the exposure by the equivalent of six stops). Use it to prevent hunting ¹⁾ or to reduce the depth of field ²⁾ .

Basic Procedure for Shooting

- 8 If required, switch on the center marker and/or safety zone (basic menu page 6 and advanced menu page 4) and zebra pattern (ZEBRA switch) in the viewfinder image.
- 9 Adjust the white balance (page 71) and black balance (page 74).
- 10 Turn the focusing ring so that the subject is sharply in focus. It may be convenient to use the EZ FOCUS button for the “easy focus” function (see page 12).
- 11 Set up the VTR according to your shooting objectives, then start recording.
 - If a camera control unit is not connected:** Press the VTR button on the camera head or on the lens.
 - If a camera control unit is connected:** Press the VTR’s record button to begin recording.

For details of VTR setup and operations, see your VTR’s operating instructions.

- During recording, the REC/TALLY indicator(s) in the viewfinder light(s), and “REC” appears on the viewfinder screen.
- Depending on the setting of the REC TIME switch (See page 13), you can display the total recording time or the length of the camera cut on the viewfinder screen.
- When recording on the DSR-1/1P, you can use the AUDIO LEVEL knob on the front of the camera head to manually adjust the channel 1 audio level. To do this, you must first set up the DSR-1/1P to enable manual adjustment of the audio recording level.

For details of this operation, see the operating instructions for the DSR-1/1P.

- 12 To pause recording, press the VTR button again.

Reviewing the recording

It is possible to review the last few seconds of the recording on the tape (recording review). Press the VTR button to pause recording, then press the RET button on the lens. Depending on how long the button is pressed, the tape is automatically rewound over the last two to ten seconds from the paused position, and then this part is played back in the viewfinder. If the RET button is kept pressing, about ten seconds of the recording review is possible. The VTR then returns to the paused state.

Note

This function may not be provided by some VTRs. Refer to the instructions for the VTR.

Shooting with the DSR-1/1P

The DXC-D30/D30P docks with the DSR-1/1P to configure the DSR-130/130P DVCAM Digital Camcorder.

The following describes how to shoot using the DSR-130/130P’s functions.

Using the ClipLink Function

The ClipLink function can be used at all stages from shooting to editing. This function makes editing operations more efficient by automatically recording index pictures (Mark IN point images) that provide a searchable index of recorded scenes, along with other data such as time code and scene numbers.

For concept of the ClipLink function, see the supplied “ClipLink™ Guide”.

- 1 Dock the DSR-1/1P to the camera head and turn on the power, then perform steps 2 to 10 from “Basic Procedure for Shooting” (page 39).
- 2 Insert a cassette into the DSR-1/1P and set ClipLink mode to ON by menu setting.

For details of this operation, see the operating instructions for the DSR-1/1P.

The following display appears on the viewfinder screen.

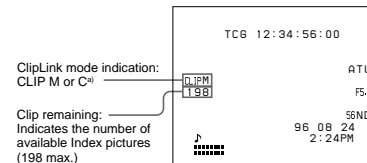

- a) For details, see “Basic menu page 7” (page 54).

To record the cassette name/number

Access basic menu page 7 to specify a name or number for the inserted cassette.

For details, see “Basic menu page 7” (page 54).

- 3 Press the VTR button on the camera head or the lens.

The DSR-1/1P starts recording, and the REC/TALLY indicator lights in the viewfinder. Meanwhile, the time code at the recording start point (Rec IN) is recorded (HH:MM:SS) in the DSR-1/1P’s internal memory.

- 4 When a shooting of the scene completes, press the VTR button on the camera head or the lens.

This pauses recording. To continue recording the next scene, repeat steps 3 and 4. The scene number will be automatically incremented.

To set/clear NG (No Good)

If you press the NG button before you start shooting the next scene, the previous scene will be designated as “NG” (the “NG” display appears in the viewfinder). Once NG has been set, you can cancel it by pressing the NG button again before you start shooting the next scene (the “NG” display in the viewfinder disappears, which means that the previous scene has been re-designated as “OK”). Each time you press the NG button before starting shooting the next scene, the status of the previous scene toggles between “NG” and “OK”. It is always the last selected status that will take effect and be stored in the cassette memory.

- 5 To finish recording, press the STOP button on the DSR-1/1P.

This stops recording.

Note

When using the ClipLink function while shooting, if you continue shooting after stopping or if you change the tape’s recording position, your subsequent shots may overwrite and erase the previously recorded ClipLink log data (time codes, scene number, etc.) or index pictures.

To avoid this problem, press the DSR-1/1P’s ClipLink CONTINUE button before restart of shooting.

For details, see the operating instructions for the DSR-1/1P.

Shooting with the DSR-1/1P

Setting Mark IN/OUT points as you shoot

Instead of continuing shots from scene to scene, you can specify Mark IN and Mark OUT points as you shoot and set scene numbers (ranging from 001 to 198).

1 Perform steps **1** and **2** from “Using the ClipLink Function” (page 41).

2 Access basic menu page 7 and perform the following operations.

1) Set MARK/CUE to MARK.
The ClipLink mode indication “CLIP M” appears on the viewfinder screen.

2) Set the cassette name or number if necessary.

For details of menu operations, see “Basic Menu Operations” (page 51).

3 Press the VTR button on the camera head or the lens.

The DSR-1/1P starts recording, and the REC/TALLY indicator(s) light(s) in the viewfinder.

4 Press the TAKE button when you find a shot where you would like to set a Mark IN point.

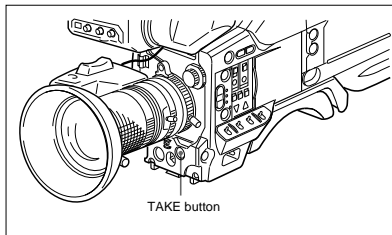

The TAKE/TALLY indicator (orange) lights in the viewfinder and “TAKE” appears on the screen.

5 Press the TAKE button when you find a shot where you would like to set a Mark OUT point.

The TAKE/TALLY indicator (orange) goes out in the viewfinder and the “TAKE” disappears from the screen.

At this time, the time code (HH:MM:SS) at the Mark IN/OUT point for scene 001 is recorded to the DSR-1/1P’s internal memory, and then recorded to the cassette memory.

To set/clear NG

If you press the NG button before you set the next Mark IN point, the previous scene will be designated as “NG” (the “NG” display appears in the viewfinder).

Once NG has been set, you can cancel it by pressing the NG button again before you set the next Mark IN point (the “NG” display in the viewfinder disappears).

6 Repeat steps **4** and **5** as needed to record (to cassette memory) time codes at Mark IN/OUT points, scene numbers, and NG designations to the cassette memory.

The scene number is automatically incremented each time you specify a Mark OUT point.

7 To finish shooting, press the VTR button on the camera head or the lens, then press the DSR-1/1P’s STOP button.

This stops the recording operation.
The index pictures of each Mark IN point are recorded onto the tape.

Setting cue points as you shoot

You can make edit search operations easier by specifying cue points to highlight scenes.

1 Perform steps **1** and **2** in “Using the ClipLink Function” (page 41).

2 Access basic menu page 7 and perform the following operations.

1) Set MARK/CUE to CUE.

The ClipLink mode indication “CLIP C” appears on the viewfinder screen.

2) Set the cassette name or number if necessary.

For details of menu operations, see “Basic Menu Operations” (page 51).

3 Press the VTR button on the camera head or the lens.

The DSR-1/1P starts recording, and the REC/TALLY indicator lights in the viewfinder. Meanwhile, the recording start point (Rec IN) is recorded in the DSR-1/1P’s internal memory.

4 Press the TAKE button when you find a shot where you would like to set a cue point.

The “CUE” indication appears (for about 1 second) on the viewfinder screen. At this point, the time code (HH:MM:SS:frame) at the cue point is recorded into the cassette memory.

5 Repeat step **4** to specify more cue points.

6 To finish shooting, press the VTR button on the camera head or the lens, then press the DSR-1/1P’s STOP button.

This stops recording operation.
Time codes (HH:MM:SS) and scene number (scene 001) are recorded to the cassette memory and the index picture of the Rec IN point is recorded onto the tape.

Using the Edit Search Function While Back Space Editing

While the DSR-1/1P is in recording pause mode, press and hold the EDIT SEARCH buttons to activate the search playback function for as long as you hold down the button. You can use the edit search function to find the desired tape location after a recording stop during back space editing or when continuing to record from any other location on the tape.

1 Dock the DSR-1/1P to the camera head and turn on the power, then insert a cassette into the DSR-1/1P.

2 Perform steps **2** to **12** in “Basic Procedure for Shooting” (page 39).

3 Press and hold either of the EDIT SEARCH buttons (REV or FWD)

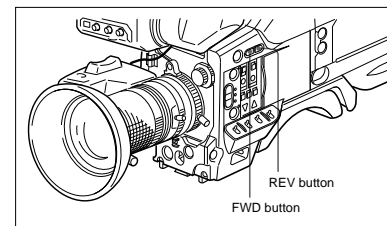

The tape is moved in reverse or forward search mode for as long as you hold down the REV or FWD button, and the image is shown in the viewfinder.

To change the playback speed

Press the REV or FWD button down firmly into the inner position to make the tape move at the faster speed. Press the button down lightly to make the tape move at the slower speed.

Note

Do not shut off the camera head’s power while using the edit search function. The DSR-1/1P may not be able to find the continue point.

(continued)



Shooting with the DSR-1/1P

- 4** Release the REV or FWD button when you find the tape location where you wish to continue shooting.

The DSR-1/1P enters recording pause mode.

- 5** Press the VTR button on the camera head or the lens.

The DSR-1/1P starts recording.

Using the Freeze Mix Function

The freeze mix function superimposes a freeze-frame image of a previously recorded shot on the shooting image displayed on the viewfinder screen.

You can use this function to easily frame a subject within the same framework from a previous shot.

Note

When the camera head is in EZ mode, the freeze mix function is disabled. Release the EZ mode beforehand. (See page 12.)

- 1 Dock the DSR-1/1P to the camera head and connect a color monitor to the MONITOR OUT connector.
- 2 Perform steps 2 to 10 from “Basic Procedure for Shooting” (page 39).
- 3 Access basic menu page 7 and move the cursor to FREEZE.

For details of menu operations, see “Basic Menu Operations” (page 51).

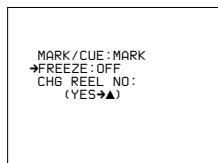

- 4** Play back the tape on which the image to be used for framework alignment has been recorded.

For details of the playback operation, see the operating instructions for the DSR-1/1P.

- A color playback image is displayed on the color monitor's screen.

- 5** Press the UP/ON button when you see the image you want to freeze.

The frozen playback image is displayed, mixed with the shooting image, in monochrome. The indication “FREEZE MIX ON” appears on the screen.

To change the freeze-frame image

Press the DSR-1/1P's PLAY button. This returns to the screen shown in step 3 above, and color playback mode begins.

Use the DSR-1/1P's tape transport buttons to find the desired image and then perform step 5 again.

- 6** Once you have framed your subject, press the UP/ON button to cancel the freeze function.

This returns to the screen shown in step 3.

- 7** Find the recording start point or insert a new cassette for recording, then begin recording.

Note

If you use the DSR-1/1P's tape transport buttons during back space editing, the back space editing mode will be stopped. When you were using the ClipLink function when shooting, if you simply restart the recording you will lose any ClipLink data that was recorded. To avoid this, press the DSR-1/1P's ClipLink CONTINUE button before restarting recording.

For details, see the operating instructions for the DSR-1/1P.

Viewfinder Screen Indications

There are four types of indication screen which appear in the viewfinder, as follows.

• Normal indications

These show the operating state of the camera and connected VTR. (See page 47.)

• Status indications

Pressing the MENU/STATUS switch up while the normal indications are present calls a display of current settings. (See page 50.)

• Basic menu

These provide settings for the lens iris, shutter speed and so forth, and also a tilting screen. (See the section “Viewfinder Basic Menu” page 51.)

• Advanced menu

These provide settings for the center marker, zebra pattern, viewfinder screen indications, and so forth. (See the section “Viewfinder Advanced Menu” page 57.)

Changing the Viewfinder Display

Use the buttons and switches shown in the following figure to switch the viewfinder display among the normal indications, basic menu pages and advanced menu pages.

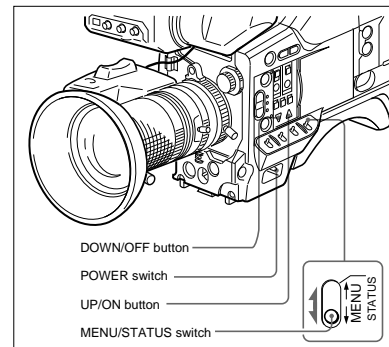

Displaying the normal indications and switching to the basic menu

To display the normal indications, move the POWER switch to the ON position.

To switch to and from the basic menu, use the MENU/STATUS switch.

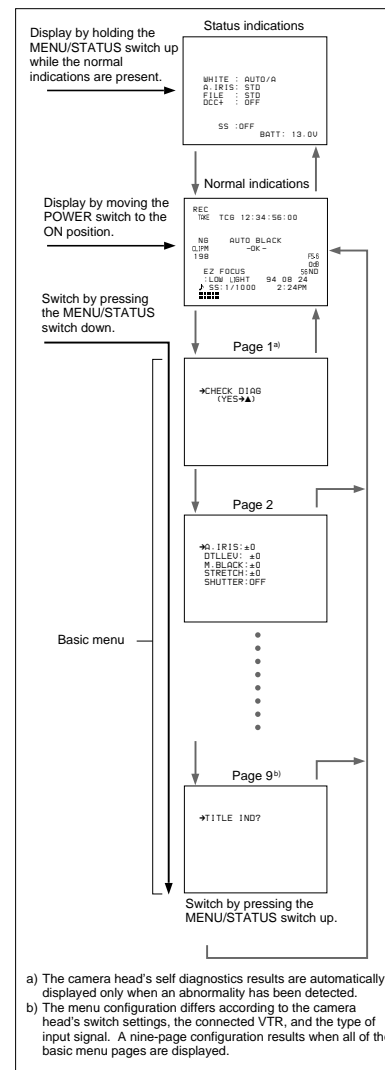

Viewfinder Screen Indications

Displaying the advanced menu and switching to the normal indications

Use the following procedure to display the advanced menu.

- 1 Move the POWER switch to the ON position while holding down the UP/ON button to display the advanced menu selection screen.
- 2 To display advanced menu page 2

immediately, move the cursor to the menu number and then press the DOWN/OFF button.

- To reinitialize all settings in the advanced menu to their factory defaults, press the UP/ON button. A confirmation screen appears. Press the UP/ON button to confirm the reinitialization, or the DOWN/OFF button to cancel it. In either case, the display now switches to advanced menu page 2.

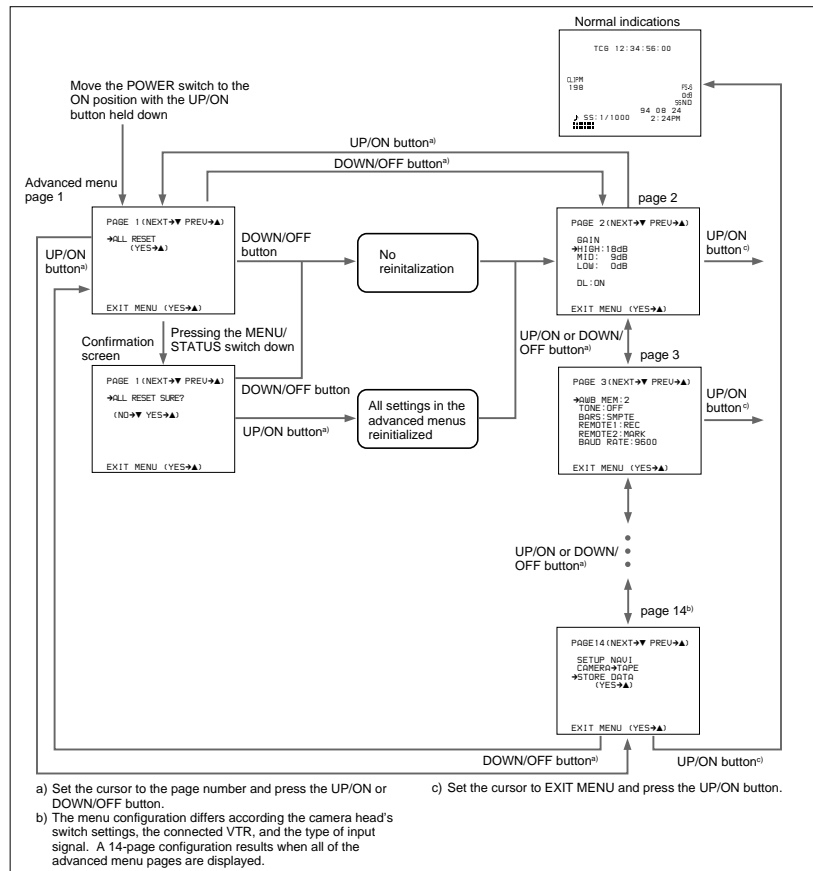

Viewfinder Normal Indications

During normal operation, the following items can be indicated in the viewfinder.

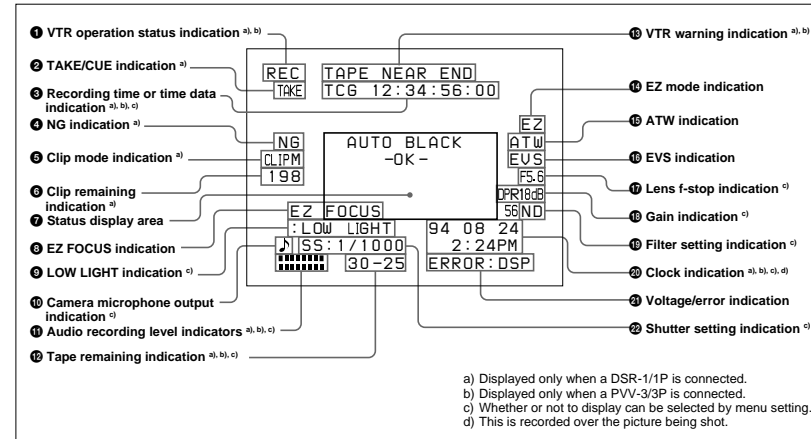

The significance of each of the indications shown in the figure is as follows.

1 VTR operation status indication

This indicates the VTR's current operation status (REC, PLAY, etc.).

2 TAKE/CUE indication

This displays a TAKE or CUE indicator when using the ClipLink function and recording with the DSR-1/IP.

TAKE: When recording in Mark mode, this indication appears when a Mark IN point is set and disappears when the next Mark OUT point is set.

CUE: When recording in CUE mode, this indication appears for about 1 second when a cue point is set.

3 Recording time or time data indication

This shows the following values.

- When the REC TIME switch on the camera is in the TTL position: The total recording time
- When the REC TIME switch on the camera is in the DUR position: The duration of the current recording cut

- With a VTR connected, when the REC TIME switch on the camera head is in the OFF position and the item TC IND in advanced menu page 6 is set to "ON": A time data value from the VTR depending on the DISPLAY switch settings on the VTR as shown in the following table

DISPLAY switch setting	Time data displayed
COUNTER	CNT: Tape transport time
TC	TCG: a time code from the time code generator TCR: a time code from the time code reader
U-BIT	UBG: a user bit value from the user bit generator

When using the DSR-1/IP, time data values appear during playback, fast forward, rewind, or recording review.

4 NG indication

An "NG" (No Good) indicator appears if you designate a recorded scene as "NG" when using the ClipLink function and recording with the DSR-1/IP.

Viewfinder Normal Indications

5 Clip mode indication

A “CLIP M” or “CLIP C” indication appears when you use the ClipLink function and record using the DSR-1/1P.

- CLIP M:** Indicates shooting in MARK mode
- CLIP C:** Indicates shooting in CUE mode

6 Clip remaining indication

The number of available index pictures remaining is displayed when you use the ClipLink function with the DSR-1/1P.

7 Status display area

One of the following values or messages is displayed to indicate the camera head's current status or its operation status.

- New values when changing camera head's settings
- Messages indicating progress or results of adjustments
- The camera head's current settings
- SetupLog data recorded to tape during shooting (*see page 69*)

Note

The status indication is not shown while the EZ FOCUS indication 8 appears.

8 EZ FOCUS indication

This appears when the EZ FOCUS button is pressed, enabling the “easy focus” function.

9 LOW LIGHT indication

This warning appears if the lighting level is inadequate.

10 Camera microphone output indication

This appears when there is an input from the camera microphone.

Note

This indication serves as a check on whether the camera microphone is operating correctly, but it does not provide confirmation that the VTR is recording sound. Check that the audio recording levels on the VTR are set correctly.

11 Audio recording level indicators

These show the recording levels of audio channels 1 and 2 on the VTR.

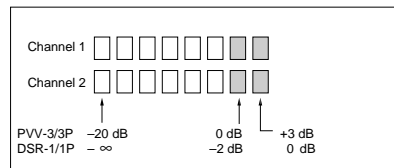

12 Tape remaining indication

This shows the tape remaining in the VTR as follows.

Indication	Tape remaining
F-30	At least 30 minutes
30-25	25 - 30 minutes
25-20	20 - 25 minutes
20-15	15 - 20 minutes
15-10	10 - 15 minutes
10-5	5 - 10 minutes
5-0	2 - 5 minutes
5-0 (flashing)	0 - 2 minutes

13 VTR warning indication

This shows warning indications about operation or status of the connected VTR.

When connecting the DSR-1/1P or PVV-3/3P

Indication	Meaning
NO TAPE	There is no tape loaded.
REC INHIBIT	The tape is in the recording inhibited state.
LOW BATT.	The battery is almost exhausted.
BATT. END	The battery is exhausted.
TAPE NEAR END	The tape is near the end.
TAPE END	The tape is at the end.
CHECK REMOTE (PVV-3/3P only)	A device other than a remote control unit (e.g. headphones) is connected to the REMOTE connector.
SERVO	The servo lock has been lost.
HUMID	There is condensation.
RF	The video heads are clogged, or there is some other fault in the recording system.
SLACK	The tape is not wound properly.
OXIDE TAPE (PVV-3/3P only)	An oxide tape has been loaded. (The tape is automatically ejected.)

Only when connecting the DSR-1/1P

Indication	Meaning
50P CONNECT	Connection with the PRO 50-pin connector on the DSR-1/1P. (Freeze mix function is disabled.)
MP TAPE	An incorrect type of cassette has been loaded. (The cassette is automatically ejected and the indication disappears in about two seconds.)
CLIP DATA ERR	Abnormality of the cassette memory data.
AUDIO 48kHz (4 flashes/s)	At back space editing, audio recording mode has changed from 32 kHz mode (4-channel mode) to 48 kHz mode (2-channel mode).
AUDIO 32kHz (4 flashes/s)	At back space editing, audio recording mode has changed from 48 kHz mode (2-channel mode) to 32 kHz mode (4-channel mode).
ERROR:91-13F	Failure in loading or saving the cassette memory data.
CLIP CONT?	Asking whether you will continue shooting in ClipLink mode or not when the cassette contains ClipLink data. (The indication disappears when you press the ClipLink CONTINUE button on the DSR-1/1P or start the next shooting without pressing it.)
CLIP NEAR END	At back space editing in ClipLink mode, capacity for only 1 to 3 index pictures remains.
CLIP END	Impossible to record any more clip shots.

14 EZ mode indication

This appears when the camera head is in EZ mode. In the EZ mode, the auto tracing white balance function operates, so the ATW indication also appears at the same time.

15 ATW indication

This appears when the ATW button is pressed, turning the indicator on. It indicates that the auto tracing white balance function is operating.

16 EVS indication

This appears when the EVS (Enhanced Vertical definition System) function is enabled. (*See page 75.*)

17 Lens f-stop indication

This shows the f-stop of the lens.

Note

Depending on the lens being used, this indication may differ slightly from the actual f-stop on the lens.

18 Gain indication

This shows the gain value, and the settings of the HYPER GAIN switch and the DPR (Dual Pixel Readout) function (*see page 57*) as shown in the following table.

Example indication	Meaning
18dB	Gain setting is 18 dB.
DPR 18dB	The DPR function is enabled. In this case the DPR function approximately doubles the gain (an increase of 6 dB) over the current gain setting (in this case 18 dB).
HYPER	The HYPER GAIN switch is in the ON position. In this case the hyper gain function increases the gain by a factor of about 60 with respect to 0 dB regardless of the current gain setting (that is, increased to 36 dB).

19 Filter setting indication

This shows the setting of the FILTER control.

Indication	Filter setting
3200	1 (3200K)
56ND	2 (5600K + 1/8ND)
5600	3 (5600K)
56ND	4 (5600K + 1/8ND)

20 Clock indication

The clock indication is shown in one of the following ways (according to the CLOCK IND setting of CAM, BARS, or OFF in advanced menu page 8).

CAM: Always displayed.

BARS: Displayed whenever color bars are displayed.

OFF: Not displayed.

If the clock indication is displayed during recording, it is recorded onto the image.

Viewfinder Normal Indications

④ Voltage/error indication

The current voltage is displayed whenever the camera head's power supply voltage dips below 11.0 V DC. However, you can also display the current voltage at any time by pressing and holding the MENU/STATUS switch in the upward position (the display is shown for as long as you hold the switch upward).

An error message is displayed when an abnormality has been detected by the auto diagnostic function (page 51). If there is a voltage drop below 11.0 V DC and an error has been detected, the low voltage indication alternates at one-second intervals with the error indication.

If an error message appears, contact your Sony dealer.

If using a VTR and an Anton Bauer Intelligent Battery System

The remaining battery capacity is shown as a percentage.

④ Shutter setting indication

When the SHUTTER switch has been set to ON, the shutter speed or CLS frequency set in basic menu page 2 is displayed here.

Status Indications

If you set the MENU/STATUS switch to STATUS while a menu is being displayed, the camera head's current setting status will be shown in this display area.

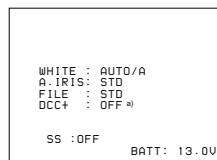

a) When both the DCC+ and DynaLatitude functions are set to OFF

Display	Description
WHITE	White balance adjustment method selection (PRE/A/B) and color temperature during auto white balance adjustment
A.IRIS	Iris adjustment method selection (STD/SPOT L/BACK L)
FILE	STD (when not using the setup files), or a selected file name (when using the setup files)
DCC+ or DL	For DCC+ indication: ON with the OUTPUT/DL/DCC+ switch set to CAM/DCC+ (DCC+ ON), and OFF with the switch set to CAM/DL and DL in advanced menu page 2 (page 57) set to OFF (both DCC+ and DynaLatitude OFF). For DL indication: When setting the OUTPUT/DL/DCC+ switch to DL and DL in advanced menu page 2 to OFF (DynaLatitude OFF), LOW, STD or HIGH is displayed according to DL LVL setting in basic menu page 3 (page 52).

Viewfinder Basic Menu

To display the basic menu pages, press the MENU/STATUS switch downward while the normal indications are being shown in the viewfinder. The basic menu configuration can include up to nine pages (the configuration depends on the switch settings and the type of connected VTR).

Basic Menu Operations

The common operations on all basic menu pages are described below.

To change the page or item

The cursor is moved downward each time you press the MENU/STATUS switch down. Once the cursor has reached the last item on a page, press down the MENU/STATUS switch to go to the next page. When the last page is being displayed, pressing down the MENU/STATUS switch returns the display to the normal indications.

The cursor is moved upward each time you press up the MENU/STATUS switch. Once the cursor has reached the first item on a page, pressing up the MENU/STATUS switch returns the display to the normal indications.

To change settings

After using the MENU/STATUS switch to move the cursor to the item on which you will change the setting, press either the UP/ON button or the DOWN/OFF button to select the desired value. To reset any item to its shipped settings, press the UP/ON button and the DOWN/OFF button at the same time.

Contents and Settings of Each Page

Each page's contents and settings are described below.

Basic menu page 1

This displays the self diagnostic results when the self diagnostic function has detected an abnormality.

Note

The "CHECK DIAG" indication appears in the status display area whenever the camera head's automatic self diagnostic function detects an abnormality. Be sure to access this page and perform error checking.

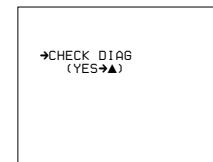

To perform error checking

Press the UP/ON button.

The error checking performs on the digital signal processing (DSP) and memory circuits and the results are displayed.

Example: If an abnormality is detected in the DSP circuit.

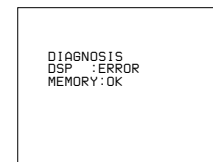

This error message "DISP ERROR" appears when the normal indications are displayed. If this message appears, contact your Sony dealer.

Viewfinder Basic Menu

Basic menu page 2

```

→A. IRIS:±0
DTL LEV: ±0
M. BLACK:±0
STRETCH:±0
SHUTTER:OFF

```

Item	Settings
A. IRIS Sets a base value for auto adjustment of lens iris.	-1.0, -0.5, ±0 (normal value), +0.5, +1.0 Negative adjustment values set a narrower lens iris and positive values set a wider lens iris.
DTL LEV Sets the detail (edge) emphasis.	-99 to ±0 (normal value) to +99 Negative adjustment values soften the image's edges and positive values sharpen them.
M. BLACK Sets the master pedestal level.	-99 to ±0 (normal value) to +99 Negative adjustment values make dark areas of the picture darker and increase the contrast. Positive adjustment values dark areas of the picture lighter and reduce the contrast.
STRETCH Sets black stretch/compress value.	-16 to ±0 (normal value) to +15 This function adjusts the intensity of dark areas of the screen. Negative values make these areas darker (black compress) and positive values make these areas brighter (black stretch).
SHUTTER Sets shutter speed or CLS/EVS setting (see page 75).	DXC-D30: 1/100 (normal value), 1/250, 1/500, 1/1000, 1/2000, EVS, CLS (60.4 Hz to 200.3 Hz) DXC-D30P: 1/60 (normal value), 1/250, 1/500, 1/1000, 1/2000, EVS, CLS (50.3 Hz to 201.4 Hz) This selects either the shutter speed or the scan frequency or EVS for the clear scan function.

Basic menu page 3

```

→SKIN DTL: 0.0
DL LVL:STD

```

Item	Settings
SKIN DTL Sets the amount of skin detail correction.	0.0 (normal value) to 1.0 Smaller values set a softer skin detail.
DL LVL Sets the DynaLatitude level.	LOW, STD (normal value), HIGH Set the amount of DynaLatitude effects as high level, standard level (STD), or low level.

Basic menu page 4

This is displayed when the SET UP switch has been set to FILE.

```

FILE: *FL
→SELECT FILE
HISAT
CHG FILE
(YES→▲)

```

For details of this operation, see "Setup Files" (page 62).

Basic menu page 5

This menu is displayed only when an external sync signal is input to the camera adaptor or VTR connected to the camera head.

```

→SC PHASE:999
H PHASE: 100

```

Item	Settings
SC PHASE Sub carrier phase adjustment for when camera is genlocked. ^{a)}	000 (normal value) to 999
H. PHASE Horizontal phase adjustment for when camera is genlocked. ^{a)}	000 to 100 (normal value) to 199

a) This applies when using an external sync signal to synchronize operation of several cameras (see page 34).

Basic menu page 6

```

MARKER: ON
→DUR TIME:
MM:SS
00:00

```

Item	Settings
MARKER Sets MARKER display ON/OFF.	ON (normal value), OFF MARKER is displayed when this setting is ON and is not displayed when it is OFF. When the setting is ON, go to Advanced Menu 4 to select the type of marker (see page 58).
DUR TIME Sets the recording time. Setting the recording time before shooting helps you with making scenes of equal duration. When shooting with displaying the recording time of the current cut in the viewfinder (with the REC TIME switch set to DUR), the recording time indication flashes to remind you that the recording time has passed.	00:00 to 59:59 (minute to second) See "Setting the recording time in seconds" and "Setting the recording time in minutes" below.

Setting the recording time in seconds

Move the cursor to DUR TIME, then press the UP/ON button or DOWN/OFF button.

A value of seconds is displayed under "SS".

```

MARKER: ON
→DUR TIME:
MM:SS
00:25

```

Setting the recording time in minutes

- 1 Press the MENU/STATUS switch to move the cursor to DUR TIME, then press the UP/ON button until the "seconds" value (under "SS") exceeds 59.

The minute value appears below "MM".

- 2 Repeat step 1 to set the desired time value.

```

MARKER: ON
→DUR TIME:
MM:SS
01:00

```

Viewfinder Basic Menu

Basic menu page 7

The following display is shown when the DSR-1/1P is connected.

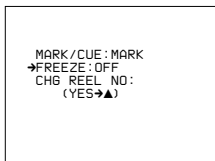

Item	Settings
MARK/CUE Selects MARK mode or CUE mode	MARK (normal value), CUE See "Using the ClipLink Function" (page 41).
FREEZE Sets the freeze mix function.	See "Using the Freeze Mix Function" (page 44).
CHG REEL NO Sets the cassette name/number	See "To set the cassette name/number" below.

To set the cassette name/number (when using DSR-1/1P)

- 1 Connect the DSR-1/1P and load a cassette.
- 2 Press the MENU/STATUS switch to move the cursor to CHG REEL NO, then press the UP/ON button.

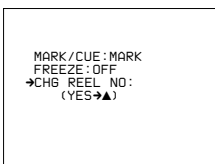

The cursor (→) changes to the text entry arrow (↓) and the current cassette name/number is displayed. ("NO TAPE" is displayed if you neglected to load a cassette.)

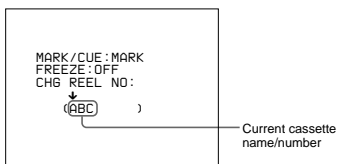

- 3 Press the MENU/STATUS switch to move the text entry arrow.

Press the MENU/STATUS switch upward to move the cursor to the right or downward to move it to the left.

- 4 Press the UP/ON button or DOWN/OFF button to enter the desired characters.

The displayed character changes each time the UP/ON button is pressed. It changes in reverse order each time the DOWN/OFF button is pressed.

- 5 Return to step 2 and repeat the text entry procedure.

- 6 After completing text entry, move the text entry cursor to the parenthesis position.

The display changes as follows.

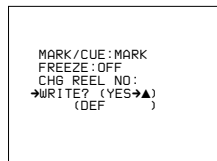

- 7 Check your cassette name/number setting, and press the UP/ON button if no more changes are required. (To make changes or to abort the procedure for this setting, return to step 2.)

This writes the new cassette name/number to the cassette memory, after which the display changes as follows.

Basic menu pages 8 and 9

You can create a title of up to four lines, each of twelve alphanumeric or punctuation characters, and then save it. It is then possible to record the title over the picture while shooting.

Entering the title (page 8)

- 1 Press the MENU/STATUS switch as necessary to display basic menu page 8 (title setting display) in the viewfinder.

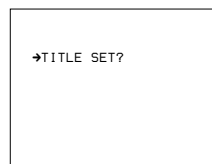

If a title is already present, it appears on this screen. To delete the displayed title, press the UP/ON and DOWN/OFF buttons simultaneously.

- 2 Press the UP/ON button. This brings up the cursor on the screen (flashing), and switches to title editing mode.

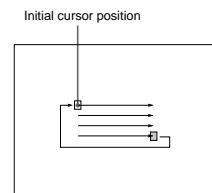

- 3 Press the DOWN/OFF button to move the cursor to the position where you wish to insert a character.

To move the cursor back

With the DOWN/OFF button held down, press the UP/ON button.

- 4 Press the UP/ON button to select the required character. Each time you press the UP/ON button, the character cycles through the following sequence.

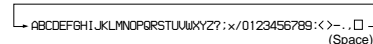

To reverse the character sequence

With the UP/ON button held down, press the DOWN/OFF button.

- 5 Press the DOWN/OFF button to confirm the character selection. The cursor advances to the next character position.

To change a character after confirming it Return to step 3, and input the character again.

- 6 Repeat steps 4 and 5 until the title is complete.

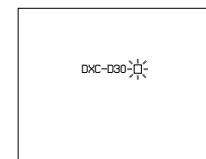

- 7 When the title is complete, press the MENU/STATUS switch as necessary to return to the normal viewfinder indications. The title created is retained, even when you power the camera off.

To record a title (page 9)

- 1 Press the MENU/STATUS switch as necessary to access basic menu page 9 (title display).

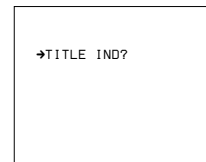

(continued)

Viewfinder Basic Menu

- 2** Press the UP/ON button once.

The title is superimposed to the picture displayed on the viewfinder screen.

- 3** Start shooting.

- 4** To stop the title recording, press the MENU/STATUS switch to clear the title display.

Note on using the CCU-M5/M5P Camera Control Unit

When the CCU-M5/M5P has a function switch setting of "TITLE ON", the title display takes precedence, and the status display (see page 48) do not appear in the normal indications. However, when you press the MENU/STATUS switch up, for as long as you hold it up the status indications appear in place of the title.

Viewfinder Advanced Menu

Bring up the advanced menu pages by setting the POWER switch to ON while pressing the UP/ON button up (see page 46).

There are up to 14 advanced menu pages (the number displayed depends on the switch settings and the type of connected VTR).

Note on using the CCU-M5/M5P Camera Control Unit

When the camera head is in EZ mode, the advanced menu may not appear. Release the EZ mode beforehand. (See page 12.)

Advanced Menu Operations

To change the page

Move the cursor to the menu number, then press the UP/ON button or the DOWN/OFF button.

Pressing the UP/ON button displays the previous page and pressing the DOWN/OFF button displays the next page. Pressing the DOWN/OFF button when the last page is being displayed returns the display to the first page.

To select items in a page

Press the MENU/STATUS switch to move the cursor among the menu items.

To change settings

This operation is the same as for the basic menus.

For a description of basic menu operations, see page 51.

To return to the normal indications

Move the cursor to EXIT MENU, then press the UP/ON button.

Contents and Settings of Each Page

Each page's contents and settings are described below.

Advanced menu page 1

Use this page to return all advanced menu settings to their factory preset values.

For details of this operation, see "Displaying the advanced menu and switching to the normal indications" (page 46).

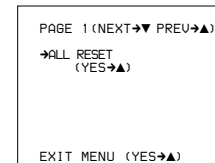

Advanced menu page 2

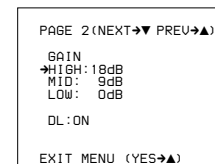

Item	Settings
GAIN This sets gain values for the positions of the GAIN switch. The HIGH, MID, and LOW values must be set so that LOW < MID < HIGH.	
HIGH Sets the H position.	3 dB, 6 dB, 9 dB, 12 dB, 18 dB (normal value), 18 dB + DPR, 24 dB + DPR, HYPER GAIN
MID Sets the M position.	0 dB, 3 dB, 6 dB, 9 dB (normal value), 12 dB, 18 dB, 18 dB + DPR, 24 dB, 24 dB + DPR
LOW Sets the L position.	-3 dB, 0 dB (normal value), 3 dB, 6 dB, 9 dB, 12 dB, 18 dB, 18 dB + DPR, 24 dB
DL Sets DynaLatitude function ON/OFF. This setting is valid only when the OUTPUT/DL/DCC+ switch has been set to DL.	ON (normal value), OFF When set to ON, the amount of DynaLatitude effects is set in basic menu page 3 (see page 52).

Viewfinder Advanced Menu

Advanced menu page 3

PAGE 3 (NEXT→▼ PREU→▲)
→AWB MEM:2 TONE:OFF BARS: SMPTE ^{a)} REMOTE1:REC REMOTE2:MARK BAUD RATE:38400
EXIT MENU (YES→▲)

a) For DXC-D30P: EBU75

Item	Settings
AWB MEM Selects whether or not to make the FILTER knob settings (1 to 4) correspond to separate white balance adjustment values stored in memory.	2 (normal value): No correspondence with FILTER knob settings. Only two adjustment values (A and B) are stored in memory. 2 × 4FL: Correspondence with FILTER knob settings. Each of the four knob settings can be used to set A and B adjustment values, for a total of eight settings.
TONE Selects whether or not to output a 1-kHz audio signal with the color bars when the OUTPUT/DL/DCC+ has been set to BARS.	ON (normal value): Output audio signal. OFF: Do not output audio signal.
BARS Selects normal width or narrower width for color bars.	SMPTE (normal value for DXC-D30): Normal width EBU75 (normal value for DXC-D30P): EBU 75% EBU100 (for DXC-D30P): EBU 100% SPLIT (for DXC-D30P): Not for normal operation SNG: Narrower than normal (used for satellite communications, etc.)
REMOTE1 Sets a function for position 1 of a switch connected to the REMOTE1 connector. ^{a)}	REC (normal value): Specifies recording start/stop MARK: Specifies a Mark IN/OUT point. CUE: Specifies a cue point. NG: Specifies NG/OK.
REMOTE2 Sets a function for position 2 of a switch connected to the REMOTE1 connector. ^{a)}	REC: Specifies recording start/stop. MARK (normal value): Specifies a Mark IN/OUT point. CUE: Specifies a cue point NG: Specifies NG/OK.
BAUD RATE Sets a baud rate for a computer connected to the REMOTE connector 1 (to be supported in future version).	9600, 38400 (normal value)

a) For more information about a connectable switch, contact your Sony dealer.

Advanced menu page 4

PAGE 4 (NEXT→▼ PREU→▲)
MARKER: CENT/90% →ZEBRA:1 ZEBRA1:70IRE ^{a)} UF: SDTL:±0 UF TALLY:×2
EXIT MENU (YES→▲)

a) For DXC-D30P: 70%

Item	Settings
MARKER Selects ON/OFF setting for center marker, size setting (percentage of viewfinder screen area), and display ON/OFF setting.	CENT/90% (normal value): Displays center marker and safety zone marker at 90% size. CENT/80%: Displays center marker and safety zone marker at 80% size. 90%: Displays only safety zone marker at 90% size. 80%: Displays only safety zone marker at 80% size. CENT: Displays only center marker.
ZEBRA Selects type of zebra pattern display.	1 (normal value): Displays the zebra pattern over parts having a video level between 70 and 90 IRE (or 70 and 90%). Use the next item (ZEBRA1) to select the base level. 2: Displays the zebra pattern over parts having video levels of 100 IRE or above (or 100% or above). 1/2: Dual display (both 1 and 2)
ZEBRA1 Sets base level for zebra pattern 1.	70 IRE (normal value) to 90 IRE or 70% (normal value) to 90% Can be set for each IRE step or 1% step.
VF S DTL Sets the detail level of images on the viewfinder screen (displayed only when the DXF-501/501CE/601/601CE viewfinder is attached).	-99 to +0 (normal value) to +99 Negative values set softer edges and positive values set sharper edges.
VF TALLY Selects whether or not to use more than one REC/TALLY indicators in the viewfinder (displayed only when the DXF-701/701CE viewfinder is attached).	×1: Uses only the upper REC/TALLY indicator. ×2 (normal value): Uses two REC/TALLY indicators.

Advanced menu page 5

PAGE 5 (NEXT→▼ PREU→▲)
→SS IND:ALWAYS LL IND:ON MIC IND:ON IRIS IND:ON GAIN IND:ON FILTER IND:ON
EXIT MENU (YES→▲)

Item	Settings
SS IND Selects the mode for showing the shutter setting when displaying the normal indications.	3SEC: Displays shutter setting for three seconds only when the setting has been changed. ALWAYS (normal value): Displays the shutter setting at all times.
LL IND Selects whether or not to show the LOW LIGHT indication on the normal indications when inadequate lighting is detected.	ON (normal value): Displays. OFF: Not display.
MIC IND Selects whether or not to show the camera microphone output indication on the normal indications.	ON (normal value): Displays. OFF: Not display.
IRIS IND Selects whether or not to show the lens's F-stop value (iris indication) on the normal indications. The F-stop value is always displayed when in EZ mode.	ON (normal value): Displays. OFF: Not display.
GAIN IND Selects whether or not to always show the gain setting indication on the normal indications.	ON (normal value): Always displays. OFF: displays for two seconds only when the setting has been changed.
FILTER IND Selects whether or not to always show the FILTER knob setting indication on the normal indications. The FILTER knob setting indicator is always displayed when in EZ mode.	ON (normal value): Always displays. OFF: Displays for two seconds only when the setting has been changed.

Advanced menu page 6

PAGE 6 (NEXT→▼ PREU→▲)
→AUDIO IND:ON TAPE IND:ON TC IND:ON ID IND:OFF ID SET:↓ ()
EXIT MENU (YES→▲)

Item	Settings
AUDIO IND Selects whether or not to show the audio level indication on the normal indications (valid only when the DSR-1/1P or PVV-3/3P is connected).	ON (normal value): Displays. OFF: Not display.
TAPE IND Selects whether or not to show the VTR's remaining tape indication on the normal indications. (valid only when the DSR-1/1P or PVV-3/3P is connected).	ON (normal value): Displays. OFF: Not display.
TC IND Selects whether or not to show the time data indication on the normal indications (valid only when the DSR-1/1P or PVV-3/3P is connected).	ON (normal value): Displays. OFF: Not display.
ID IND Selects whether or not to display the camera ID when displaying color bars.	ON (normal value): Displays. OFF: Not display.
ID SET Sets the camera ID (up to eight characters, including alphanumerics, symbols, and spaces).	See "To set the camera ID" on next page.

Viewfinder Advanced Menu

To set the camera ID

- 1 Press the MENU/STATUS switch to move the cursor to ID SET.

The cursor (→) changes to the text entry arrow (↓).

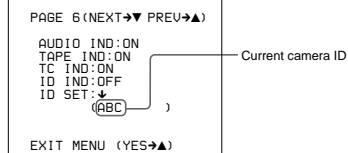

- 2 Press the MENU/STATUS switch to move the text entry arrow.

Press the MENU/STATUS switch upward to move the cursor to the right or downward to move it to the left.

- 3 Press the UP/ON button or DOWN/OFF button to enter the desired characters.

The displayed character changes each time the UP/ON button is pressed. It changes in reverse order each time the DOWN/OFF button is pressed.

- 4 Return to step 2 and repeat the text entry procedure.

- 5 When you have finished entering the text, move the cursor to the parenthesis position.

This clears the displayed menu and returns to the normal indications.

Advanced menu page 7

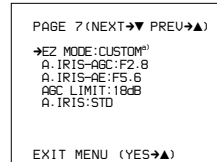

a) At shipping, the EZ MODE is set to STD.

Item	Settings
EZ MODE When the EZ MODE button has been set to EZ mode ON, this selects whether or not to change the settings of other switches and menus to the standard settings. (The EZ mode function cannot be used during remote operation.)	STD (normal value): Changes settings to standard settings. CUSTOM: Changes only some settings to standard settings. <i>For details of the settings when STD or CUSTOM is specified, see "EZ mode settings" on the next page.</i>
A.IRIS-AGC Selects auto iris adjustment which sets an F-stop value that can be switched to AGC (displayed only when the EZ MODE is set to CUSTOM).	F1.8, F 2.8 (normal value), F4, F5.6
A.IRIS-AE Selects auto iris adjustment which sets an F-stop value that can be switched to AE (displayed only when the EZ MODE is set to CUSTOM).	F5.6, F8, F11, F16 (normal value)
AGC LIMIT Sets an upper limit value for AGC adjustment (displayed only when the EZ MODE is set to CUSTOM).	0 dB, 3 dB, 6 dB, 9 dB, 12 dB (normal value)
A.IRIS Selects between standard method and intelligent method for auto iris control (displayed only when the EZ MODE is set to CUSTOM).	STD (normal value): Standard AI: "Intelligent" method: Enables selection of an appropriate adjustment value when shooting a dark subject against a bright background or a bright subject against a dark background.

EZ mode settings

The following settings are set for the camera head when EZ mode has been selected.

Item	Setting	
	STD	CUSTOM
Setup file	STD	Selectable
Detail level	±0	Setting of selected file
Master black	±0	Setting of selected file
Black stretch	±0	Setting of selected file
Skin detail	OFF	OFF
Shutter	OFF (AE mode)	OFF (AE mode)
Freeze mix	OFF	OFF
Gain	AGC mode	AGC mode
Hyper gain	OFF	OFF
Iris control method	Automatic	Automatic
Auto iris control mode	STD	STD
Iris override	±0	Selectable
Color bar output	Not output	Not output
AGC upper limit	12dB	Selectable
AGC's F stop value	F2.8	Selectable
AE's F stop value	F16	Selectable
ATW	ON	ON
DynaLatitude	OFF	OFF
DCC+	ON	ON
F-stop value indication	ON	ON
Filter indication	ON	ON
Clock indication	OFF	OFF

Advanced menu page 8

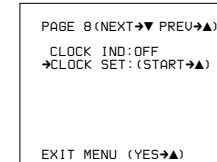

Item	Setting
CLOCK IND Selects whether or not to display the date/time on the normal indications.	OFF (normal value): Not display. CAM: Displays. BARS: Displays only when color bars are displayed.
CLOCK SET Sets date/time.	See "Setting the Clock and Timestamping Recordings" (page 77).

Advanced menu pages 9 to 12

These pages are displayed only when the SET UP switch has been set to FILE.

For details of this operation, see "Setup Files" (page 62).

Advanced menu pages 13 and 14

These pages are displayed only when a DSR-1/IP has been connected.

For details of this operation, see "Using SetupNavi and SetupLog with the DSR-1/IP" (page 67).

Setup Files

You can use setup files to reproduce a particular configuration of settings. You can also revise the contents of setup files. There are eight types of setup files, of which five are factory preset setup files and the other three are user files.

Note on using an RM-M7G Remote Control Unit
When an RM-M7G is connected to the camera head, the setup file function cannot be used. To make it possible to use this function, power OFF the camera head after disconnecting the RM-M7G, then power ON the camera head again.

Calling up a Setup File

This describes how to call up a setup file and use it to replace the current menu settings.

- 1 Set the SET UP switch to FILE.

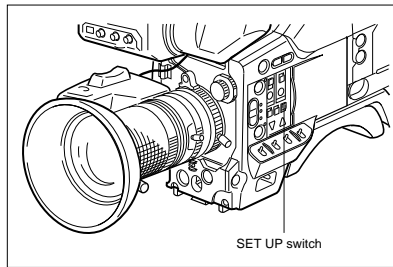

The camera head is set according to the currently-selected file data.

- 2 Access basic menu page 4.

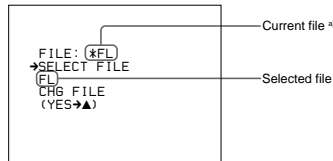

a) An asterisk (*) appears in front of any factory preset file whose contents have been revised at least once.

- 3 Move the cursor to SELECT FILE and use the UP/ON button or the DOWN/OFF button to select the desired file.

Press the UP/ON button or DOWN/OFF button repeatedly until the desired file name is displayed.

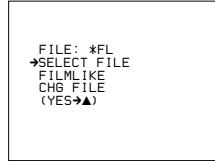

File	Description
STD	Settings for shooting under standard conditions
HI SAT	Settings for making pictures vivid
FL	Settings for shooting under fluorescent lighting
FILMLIKE	Settings for making pictures like ones shot by film camera
SVHS/VHS	Settings to optimize camera image for recording and playback characteristics of S-VHS, VHS, or Hi-8 tape
USER1 to USER3	User setup files (set to STD at shipping)

- 4 Move the cursor to CHG FILE and press the UP/ON button.

The display changes as shown below and the selected file is called up.

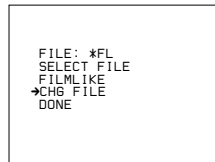

You can also call up these files via a similar operation in advanced menu page 9. In this page, a file recorded onto a tape can also be called up (when using the DSR-1/1P).

For details, see "To call up files recorded onto a tape (when using the DSR-1/1P)" (page 63).

To call up files recorded onto a tape (when using the DSR-1/1P)

First, connect the DSR-1/1P to the camera head and load the cassette that contains the recorded files.

- 1 Set the SET UP switch to FILE.
- 2 Access advanced menu page 9.

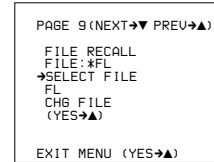

- 3 Move the cursor to SELECT FILE and use the UP/ON button or the DOWN/OFF button to select TAPE.

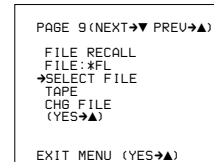

- 4 Move the cursor to CHG FILE and press the UP/ON button.

The screen appears as shown below.

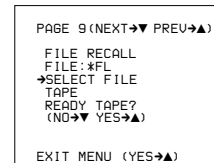

- 5 Press the UP/ON button to call up the file. To abort the call up operation, press the DOWN/OFF button (the display returns to the one shown in step 3).

During the call up operation, the following display appears.

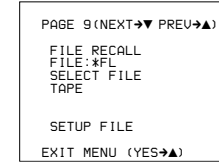

When the call up operation ends, the display changes as shown below.

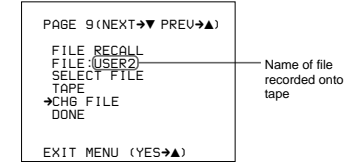

The settings of the camera head are now replaced by the settings in the called file.

Setup Files

Changing File Settings

When using advanced menu page 10 or 11, you can change the settings about picture quality in setup files. (In basic menu page 2, a part of items are changeable.) The changes are accepted only until another file is called up, after which the original settings are restored. If you save the changes, store the modified file as one of the user files or record it in a cassette. (See the following section "Saving File Settings".)

- 1 Perform the steps described in "To call up files recorded onto a tape (when using the DSR-1/1P)" above to call up the selected file.
- 2 Access advanced menu page 10 or 11.

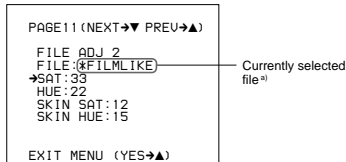
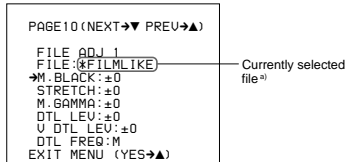

- a) An asterisk (*) appears in front of any factory preset file whose contents have been revised at least once.

- 3 Make the desired changes.

Page 10

Item	Settings
M.BLACK, STRETCH and DTL LEV	See "Basic menu page 2" (page 52).
M.GAMMA	-99 to ±0 (normal value) to +99
Adjusts the gamma curve.	
V DTL LEV	-99 to ±0 (normal value) to +99
Adjusts the vertical detail.	
DTL FREQ	LL, L, M (normal value), H, HH
Adjusts the central frequency of the detail.	

Page 11

Item	Settings
SAT	-99 to ±0 (normal value) to +99
Adjusts the saturation of the image.	Negative adjustment values decrease the saturation and positive adjustment values increase the saturation.
HUE	-99 to ±0 (normal value) to +99
Adjusts the hue of the image.	
SKIN SAT	-99 to ±0 (normal value) to +99
Adjusts the saturation in the specified area of the image.	Negative adjustment values decrease the saturation and positive adjustment values increase the saturation.
SKIN HUE	-99 to ±0 (normal value) to +99
Adjusts the hue in the specified area of the image.	

Saving File Settings

Files whose settings have been changed for certain shooting conditions can be saved as a user file or onto a tape (when using the DSR-1/1P).

For details, see "To save setup files to a tape (when using the DSR-1/1P)" (page 65).

- 1 Set the SET UP switch to FILE.

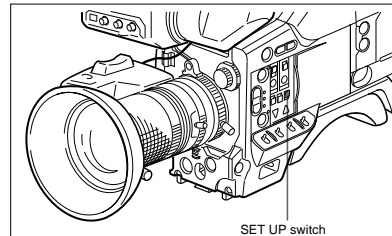

- 2 Call up a setup file whose settings approximate the desired shooting conditions and then change some of the settings.

For details of this operation, see "Calling up a Setup File" (page 62), "Changing File Settings" (page 64), "Basic Menu Operations" (page 51), and "Advanced Menu Operations" (page 57).

- 3 Access advanced menu page 12.

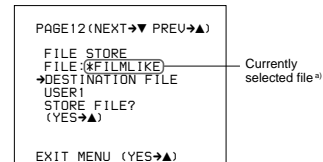

- a) An asterisk (*) appears in front of any factory preset file whose contents have been revised at least once.

- 4 Move the cursor to DESTINATION FILE and repeatedly press the UP/ON button or the DOWN/OFF button to select USER1, USER2, or USER3.

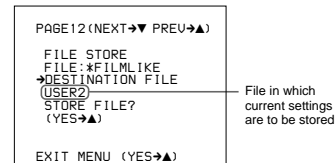

- 5 Press the UP/ON button to move the cursor to STORE FILE?.

The display changes as shown below.

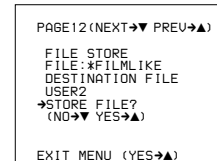

- 6 Press the UP/ON button to store the file. To abort the save operation, press the DOWN/OFF button (the display returns to the one shown at step 4).

When the save operation is finished, the display changes as shown below.

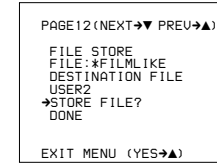

To save setup files to a tape (when using the DSR-1/1P)

Connect the DSR-1/1P to the camera head and load the tape onto which the file will be recorded.

- 1 Perform steps 1 to 4 of "Saving File Settings" and select TAPE as the file saving destination.

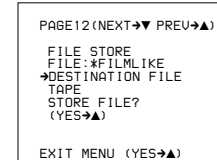

- 2 Press the UP/ON button to move the cursor to STORE FILE?.

The display changes as shown below.

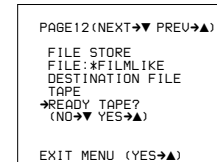

(continued)

Setup Files

- 3 Press the UP/ON button to store the file. To abort the save operation, press the DOWN/OFF button (the screen returns to the screen shown in step 2).

The tape automatically rewinds and recording starts.

The display changes as shown below, which includes color bars. ("CAN NOT WRITE" appears on the screen if no tape is loaded or if the loaded tape is write-protected.)

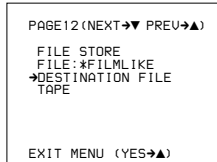

After the settings are stored, the following display appears.

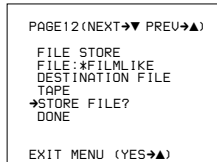

Using SetupNavi and SetupLog with the DSR-1/1P

The SetupNavi function records the setup menu and setup files onto a tape, so that the same settings can be called up and used again or copied to another camera. The SetupLog function records a camera settings every few seconds at shooting and displays the recorded data in the viewfinder during playback.

Note on using an RM-M7G Remote Control Unit

When an RM-M7G is connected to the camera head, you can use neither the SetupNavi function nor the SetupLog function. To make it possible to use these functions, power OFF the camera head after disconnecting the RM-M7G, then power ON the camera head again.

Setting up the camera Using Data Recorded on Tape

The procedure to replace camera's menu settings with settings recorded onto video tape is described here.

- 1 Connect the DSR-1/1P and insert the cassette onto which the data was recorded. Set the SETUP switch to FILE, then set the POWER switch to ON while holding down the UP/ON button.

Advanced menu page 1 appears.

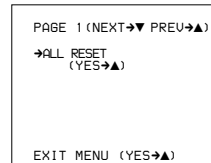

- 2 Repeatedly press down on the MENU/STATUS switch until advanced menu 13 appears.

For details of menu operation, see "Advanced Menu Operations" (page 57).

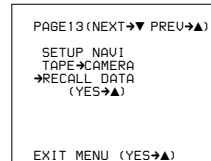

"NO TAPE" is displayed if you neglected to load a cassette.

- 3 Press the UP/ON button to call up the data recorded on the tape. (Press the DOWN/OFF button to cancel).

The display changes as follows and the call up operation begins.

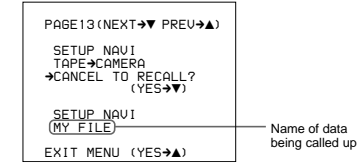

To abort the call up operation while in progress Press the DOWN/OFF button.

The following display appears.

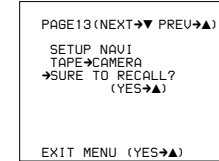

- 4 Press the UP/ON button.

After the data has been read, the following display appears.

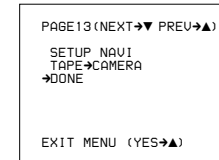

The previous menu settings are overwritten by the data recorded on the tape.

- 5 Change the menu settings if necessary.

Using SetupNavi and SetupLog with the DSR-1/1P

Recording the Menu Settings onto a Tape

1 Connect the DSR-1/1P and load the tape onto which the settings are to be recorded. Turn the camera power on.

2 Make your basic menu settings.

For details of this operation, see “Basic Menu Operations” (page 51).

3 Again, set the POWER switch to ON while holding down the UP/ON button.

4 Make your advanced menu settings.

For details of this operation, see “Advanced Menu Operations” (page 57).

5 Access advanced menu page 14.

```
PAGE14 (NEXT→▼ PREU→▲)
SETUP NAVI
CAMERA→TAPE
→STORE DATA (YES→▲)
EXIT MENU (YES→▲)
```

“NO TAPE” appears if you neglected to load a cassette.

6 Press the UP/ON button.

The following display appears.

```
PAGE14 (NEXT→▼ PREU→▲)
SETUP NAVI
CAMERA→TAPE
→SURE TO STORE? (YES→▲)
NAME SET :
( )
EXIT MENU (YES→▲)
```

7 Set the cursor to “NAME SET” and press the UP/ON button to record the menu setting onto the tape. (Press the MENU/STATUS switch to cancel.)

The cursor (→) changes to the text entry cursor (↓).

```
PAGE14 (NEXT→▼ PREU→▲)
SETUP NAVI
CAMERA→TAPE
SURE TO STORE? (YES→▲)
NAME SET :
↓
( )
EXIT MENU (YES→▲)
```

8 Enter a name for the data.
Moving the text entry cursor: Press the MENU/STATUS switch up to move the cursor to the right, and press the MENU/STATUS switch down to move the cursor to the left.
Selecting the character: Press the UP/ON or DOWN/OFF button repeatedly until the desired character appears.

9 After completing text entry, move the cursor to the parenthesis position.

The display changes as follows.

```
PAGE14 (NEXT→▼ PREU→▲)
SETUP NAVI
CAMERA→TAPE (YES→▲)
→NAME SET : (YES→▲)
MY FILE
EXIT MENU (YES→▲)
```

10 Move the cursor to “SURE TO STORE?” and press the UP/ON button to record the menu settings onto the tape (press the MENU/STATUS switch to cancel).

The display changes as follows and the data recording begins.

```
PAGE14 (NEXT→▼ PREU→▲)
SETUP NAVI
CAMERA→TAPE
→CANCEL TO STORE (YES→▼)
SETUP NAVI
(MY FILE)
EXIT MENU (YES→▲)
```

— Name of data being recorded

To abort the data recording while in progress
Press the DOWN/OFF button.

After the data has been recorded, the following display appears.

```
PAGE14 (NEXT→▼ PREU→▲)
SETUP NAVI
CAMERA→TAPE
→STORE DATA
DONE
EXIT MENU (YES→▲)
```

Viewing SetupLog Data

1 Connect the DSR-1/1P and load the tape that contains the recording to be viewed. Turn the camera power on.

2 Play back the tape.

For details of playback operation, see the operating instructions for the DSR-1/1P.

3 Press the MENU/STATUS switch up to the STATUS side.

The display changes to page 1 of the status display.

```
PLAY TCR 12:34:56:00
SETUP LOG 1/3 EZ
WHITE : A 5600 ATW
A.IRIS : SPOT L EVS
SETUP FILE: STD FS.6
DCC+ : OFF 09:58
SKIN DTL : OFF SEND
94 08 24
2:24PM
```

— Settings during recording

Each time you press upward the MENU/STATUS switch, the status display cycles through the status pages and playback display in the order: page 2, page 3, the playback display (containing the current settings), and page 1.

Status display (page 2)

```
PLAY TCR 12:34:56:00
SETUP LOG 2/3 EZ
A.IRIS : ±0 ATW
DTL LEV : ±10 EVS
M.BLACK : ±0 FS.6
STRETCH : ±0 09:58
SS : OFF SEND
94 08 24
2:24PM
```

Status display (page 3)

```
PLAY TCR 12:34:56:00
SETUP LOG 3/3 EZ
M.GAMMA : ±0 ATW
U.DTL LEV : +50 EVS
DTL FREQ : M FS.6
SKIN SAT : ±0 09:58
SKIN HUE : ±0 SEND
SAT: ±0 94 08 24
HUE: ±0 2:24PM
```

Notes

- SetupLog data is not recorded while SetupNavi data or a setup file is being recorded onto a tape. (If you play back a tape containing SetupNavi data or a setup file, the data displayed in the setup display is not the SetupLog data of the playback picture.)
- In the following cases, changed settings that were not recorded may appear as blank settings.
 - SetupLog data is overwritten at intervals of a few seconds during recording. If the settings are changed frequently for certain items, it may not always be recorded in time.
 - If the recording time is very short, recording may be ended before all of the data has been overwritten.

White Balance Adjustment

Adjusting the white balance ensures that as lighting conditions change white objects remain white in the image and tones remain natural.

The color of light emitted varies from one light source to another, and as the lighting changes the apparent color of an illuminated subject changes. It is therefore necessary to adjust the white balance each time the principal lighting source changes.

Saving an Appropriate White Balance Value in Memory

You can save two white balance values in separate memories, A and B. Unless changed, the saved values are retained for approximately ten years, even when the camera is powered off.

Once a value is saved, you can automatically restore the adjustment by moving the W. BAL switch to the A or B position. This makes shooting under alternating lighting conditions easy.

Separate white balance values for each FILTER control setting

In the default case, as described above, the same two A and B white balance values apply to all settings of the FILTER control. It is possible, however, to change the AWB MEM menu setting (see page 58) so that there are eight possibly different values for each of the A and B positions and for the four FILTER control settings.

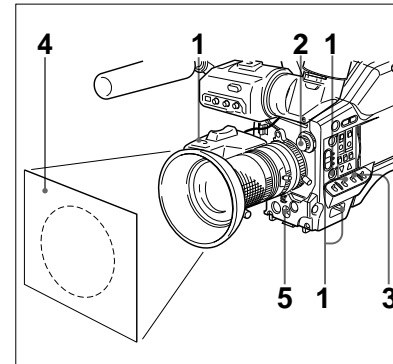

- 1 Make the following settings on the camera.
 - POWER switch: ON SAVE
 - OUTPUT/DL/DCC+ switch: one of the CAM positions
 - Lens iris selector: A (automatic)
 - ATW button: off
- 2 Set the FILTER control according to the lighting conditions. (See page 39.)
- 3 Set the W. BAL switch to A or B.
- 4 Arrange a white subject (paper, cloth, etc.) under the same lighting conditions as for shooting, and zoom in on it so that as far as possible the whole screen is white. The minimum white area requirements for the adjustment are shown in the following figure.

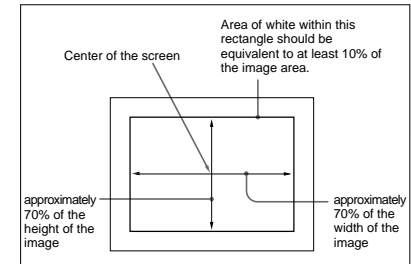

- 5 Push the WHT/BLK switch in the WHT direction and release. The white balance adjustment is carried out. During the adjustment the legend "AUTO WHITE -OP-" appears in the viewfinder. After a few seconds the adjustment is complete, and the legend in the viewfinder changes to "AUTO WHITE -OK-" plus a color temperature, as shown in the following figure.

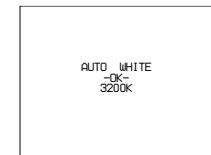

White Balance Adjustment

The adjustment value is automatically saved in memory A or B as selected above.

To save the white balance adjustment for different lighting conditions, repeat steps **2** to **4** above. You can save two different values for the white balance, in memories A and B.

Notes

- When using a camera control unit, if the W/B BALANCE switch of the camera control unit is set to PRESET or MANUAL, it is not possible to carry out white balance adjustment on the camera.
- When using a CCU-M5/MSP Camera Control Unit, make sure that the MODE switch of the CCU-M5/MSP is in the CAM position.

To recall a white balance value from memory

Before beginning shooting, set the W. BAL switch to the A or B position. This automatically sets the camera to the white balance adjustment saved in the corresponding memory.

If white balance adjustment cannot be completed automatically

The warning message "AUTO WHITE -NG-" appears in the viewfinder.

Make the necessary corrections, then carry out the process again.

Warning messages for white balance adjustment

Message	Meaning and corrections to be made
AUTO WHITE -NG- :LOW LIGHT TRY AGAIN	<p>Light level is too low.</p> <ul style="list-style-type: none"> Increase the illumination level, open the iris, or use the GAIN switch to increase the video signal level. Check the setting of the FILTER control. After these checks, retry the adjustment.
AUTO WHITE -NG- : ?? TRY AGAIN	<p>The subject is not white, or the lighting level is too high.</p> <ul style="list-style-type: none"> Use a white subject. Lower the illumination level, stop down the iris, or use the GAIN switch to decrease the video signal level. Check the setting of the FILTER control. After these checks, retry the adjustment.

AUTO WHITE -NG- :C.TEMP.LOW CHG.FILTER TRY AGAIN	<p>The color temperature is too low. Try the following, in this order of precedence.</p> <ol style="list-style-type: none"> If the FILTER control is in position 2, 3 or 4, change it to position 1, then retry the adjustment. Check that the subject is completely white, then retry the adjustment. The color temperature may be outside the range of the camera. Fit an appropriate color temperature conversion filter, then retry the adjustment.
AUTO WHITE -NG- :C.TEMP.HI CHG.FILTER TRY AGAIN	<p>The color temperature is too high. Try the following, in this order of precedence.</p> <ol style="list-style-type: none"> If the FILTER control is in position 1, change it to position 2, 3 or 4, then retry the adjustment. Check that the subject is completely white, then retry the adjustment. The color temperature may be outside the range of the camera. Fit an appropriate color temperature conversion filter, then retry the adjustment.
WHITE:PRESET	<p>The W. BAL switch is in the PRESET position. Move the W. BAL switch to the A or B position.</p>
BARS	<p>The camera is outputting a color bar signal. Move the OUTPUT/DL/DCC+ switch to one of the CAM positions.</p>

Using the Preset White Balance Settings

The camera provides two preset white balance settings, for instant shooting with approximately the correct adjustment.

There are also particular shooting conditions under which the preset values may give better results than the human eye adjustment.

- Set the W. BAL switch to PRESET.
- Set the FILTER control.

The white balance is automatically adjusted for 3200 K when the FILTER control is in position 1 or 2, and for 5600 K in position 3 or 4.

Light Sources and Color Temperature

Adjustment of the white balance to match the light source is essential to ensure correct color rendering. The color of a light source is indicated as a color temperature in kelvins (K). It is higher for bluish light, and lower for reddish light. When the camera is shipped it is adjusted for use with video lights (halogen lamps with a color temperature of 3200 K). For use with other light sources, therefore, adjustment is required.

First use the FILTER control to set the approximate color temperature, then carry out white balance adjustment.

The following table shows typical color temperature values for different light sources.

Light source		Color temperature (K)	
Natural	Artificial		
Clear sky		↑	10,000
Light cloud			8,000
Cloudy or rainy skies		Blue light	7,000
	Fluorescent light (daylight white)	↑	6,000
	Mercury lighting	↓	5,000
Direct sunlight, noon	Fluorescent light (white)	White light	
One hour after sunrise or before sunset	Fluorescent light (warm white)	↑	4,000
	Studio lighting		3,500
	Halogen lamps and video lights	Yellow light	3,000
Thirty minutes after sunrise or before sunset	Incandescent lighting	↑	2,500
	Sodium street-lighting		
Sunrise or sunset	Candlelight	Red light	2,000

Using the ATW (Auto Tracing White Balance) Function

The ATW function continuously adjusts the white balance automatically to adapt to changes in lighting conditions.

Note

Depending on the shooting conditions, automatic adjustment may not necessarily give optimum results. For the best possible results, use the W. BAL switch.

To use the ATW function

Press the ATW button turning the indicator on. This activates the ATW function, and the ATW indication appears in the viewfinder.

To disable the ATW function, press the ATW button again, turning the indicator off.

If the ATW function does not operate correctly

A warning message appears in the viewfinder as shown in the table below.

Message	Meaning and corrections to be made
:C.TEMP.LOW	If the FILTER control is in position 2, 3 or 4, change it to position 1, then retry the ATW operation.
:C.TEMP.HIGH	If the FILTER control is in position 1, change it to position 2, 3 or 4, then retry the ATW operation.

Black Balance Adjustment

Correct adjustment of the black balance is important for optimum operation of a video camera. It is necessary when using the camera for the first time or after a significant period out of use, and also when there has been a sudden change in temperature. The adjustment value is saved in memory, and readjustment is not normally necessary after powering the camera off or simply when lighting conditions change.

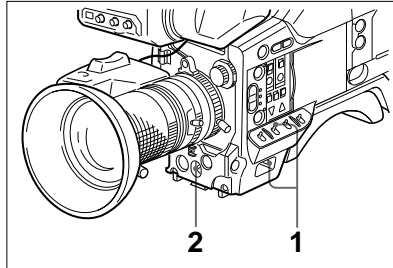

- 1 Move the POWER switch to the ON SAVE position, and check that the OUTPUT/DL/DCC+ switch is in one of the CAM positions.
- 2 Push the WHT/BLK switch in the BLK direction and release. The lens iris closes, and black balance adjustment is carried out. During the adjustment the legend "AUTO BLACK -OP-" appears in the viewfinder.

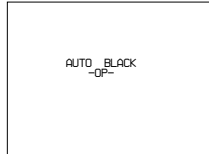

After a few seconds the adjustment is complete, and the legend in the viewfinder changes to "AUTO BLACK -OK-".

Notes

- When using a camera control unit, if the W/B BALANCE switch of the camera control unit is set to MANUAL, it is not possible to carry out black balance adjustment on the camera.
- When using a CCU-M5/M5P Camera Control Unit, make sure that the MODE switch of the CCU-M5/M5P is in the CAM position.

If black balance adjustment cannot be completed automatically

The warning message "AUTO BLACK -NG-" appears in the viewfinder.

Make the necessary corrections, then carry out the process again.

Warning messages for black balance adjustment

Message	Meaning and corrections to be made
AUTO BLACK -NG- : IRIS NOT CLOSED TRY AGAIN	The lens iris did not close fully. Check whether the lens cable is connected properly, and whether there is a fault in the lens. If a second attempt to carry out the adjustment fails, consult your Sony dealer.
AUTO BLACK -NG- : ?? TRY AGAIN	The iris opened during adjustment or there is a hardware error. Close the iris and try again. If this fails, consult your Sony dealer.
BARS	The camera is outputting a color bar signal. Move the OUTPUT/DL/DCC+ switch to one of the CAM positions.

Shutter Settings

This section covers the settings for electronic shutter speed, CLS (clear scan) and EVS function. The new value for the shutter speed or clear scan frequency and EVS setting remains set until changed, even when the camera is powered off.

Shutter speeds

There are five shutter speeds, from $1/100$ s (DXC-D30) or $1/60$ s (DXC-D30P) to $1/2000$ s. Increasing the shutter speed reduces blurring when shooting a fast-moving subject. It is also possible to reduce flicker when shooting under fluorescent lighting by changing the shutter speed.

CLS (Clear Scan) function

When shooting a computer screen or projected image, horizontal bands may appear in the camera image. This is because the vertical scan frequency of the computer-generated image is different from the vertical scan frequency of the video system. The clear scan function allows you to select a vertical scan frequency to reduce this interference.

EVS (Enhanced Vertical Scan)

This function enhances the vertical scan resolution from 400 to 450 lines (or 450 to 530 lines) to reduce flicker. However, this increases the aliasing.

Setting the shutter speed, CLS and EVS function

Notes on setting the shutter speed

- The faster you make the shutter speed, the darker the image becomes. Check the brightness in the viewfinder, and if necessary increase the lighting level or adjust the iris.
- When the shutter speed is very fast, shooting a high intensity subject may cause long vertical tails to appear on the highlights (smear).

Note on setting the CLS function

The vertical scan frequencies of computer screens vary, and it may not be possible to eliminate the interference patterns entirely. Note also that the vertical scan frequency may change depending on the software being run.

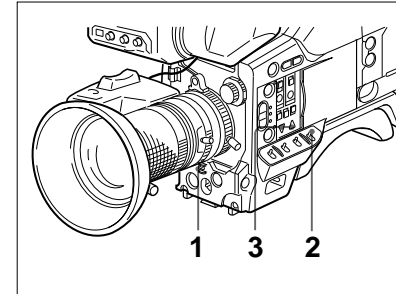

- 1 Set the SHUTTER switch to the ON position.

The SHUTTER indicator in the viewfinder comes on, and it is now possible to change the shutter speed or clear scan frequency setting and to set the EVS function. (If the EVS is already selected, the SHUTTER indicator will not light.)

- 2 Operate the MENU/STATUS switch to align the cursor with the item "SHUTTER" in basic menu page 1.

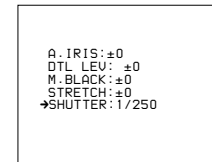

- 3 Press the UP/ON button or DOWN/OFF button to select the required shutter speed, scan frequency or EVS. Each time you press the UP/ON button or DOWN/OFF button, the shutter speed or clear scan frequency setting changes in the following order:

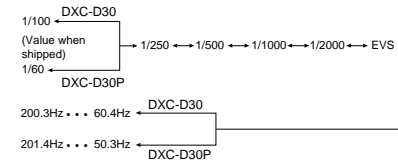

Shutter Settings

When using the clear scan function

Watching the monitor screen, adjust the frequency to give minimum interference.

If there is a black band in the monitor image, reduce the frequency, and if there is a white band, increase the frequency.

To return from the basic menu to the normal indications

Press the MENU/STATUS switch as many times as necessary until the normal indications appear. The new setting of the shutter speed or clear scan frequency appears in the normal screen display.

When shooting is finished

Set the SHUTTER switch to the OFF position. The SHUTTER indicator in the viewfinder goes off.

Setting the Clock and Timestamping Recordings

Use advanced menu page 8 to set the camera head's internal clock and record the date and time.

Note

If the following date/time setting procedure for the internal clock does not cause the date/time information to be displayed in advanced menu page 8, it may be due to a worn-out lithium battery in the camera head. See page 21 and replace the lithium battery.

How to set the date and time

- 1 Access advanced menu page 8.

For details of menu operations, see "Advanced Menu Operations" (page 57).

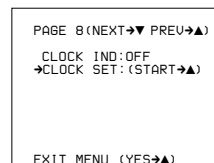

- 2 Move the cursor to CLOCK SET, then press the UP/ON button.

The following display appears, in which the year indication is flashing.

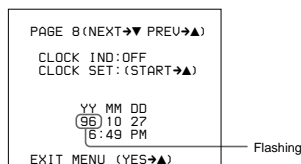

- 3 Press the MENU/STATUS switch and the UP/ON button to set the desired date and time.
 - 1) Press the MENU/STATUS switch up or down until the item to be changed starts flashing.
 - 2) Press the UP/ON button to change the number.

Repeat 1) and 2) until you have completed your date and time settings.

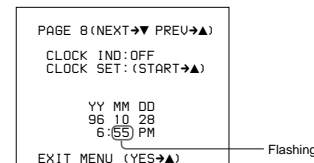

- 4 Select whether to display a 12-hour clock (showing AM and PM hours) or a 24-hour clock.
 - 1) Press the MENU/STATUS switch up or down to select the desired setting (12-hour clock display or 24-hour clock display).

Example of 12-hour clock display: 6:49 PM
("6" and "PM" are flashing)

Example of 24-hour clock display: 18:49 ("18" is flashing)

- 2) Press the UP/ON button.

- 5 Press the UP/ON button to select the date display format.

Each press of the UP/ON button cycles through the following options.

- Year-month-day: YY MM DD
96 10 27
- Month-day-year: MM DD YY
10 27 96
- Day-month-year: DD MM YY
27 10 96

- 6 Press the MENU/STATUS switch down.

The cursor is shown at the CLOCK SET position.

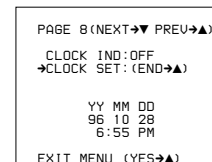

- 7 Press the UP/ON button (to a time signal).

The clock starts from 00 seconds. The clock display can be viewed if CLOCK IND has been set to ON.



Setting the Clock and Timestamping Recordings

Timestamping recordings

You can timestamp recordings by superimposing the current date and time.

- 1 Before shooting, set the CLOCK IND to CAM in advanced menu page 8.

The date and time appear in the viewfinder, and are superimposed on the video signal output from the camera.

- 2 To stop superimposing the date and time, set the CLOCK IND to OFF.

Viewfinder Screen Adjustments

The following adjustments are provided to improve the visibility of the viewfinder screen.

Although these adjustment may make the viewfinder image clearer, they have no effect on the output video signal from the camera.

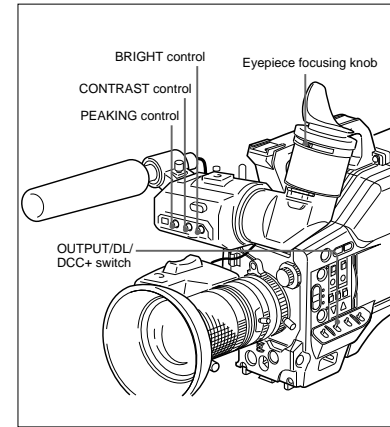

Adjusting the eyepiece focus

Depending on the eyesight of the camera operator — whether longsighted or shortsighted — the optimal position of the viewfinder image varies. Adjust the eyepiece focus to get the clearest viewfinder image for your eyesight. First focus the image with the lens, then adjust the eyepiece focusing knob. The adjustment range is from -3 to 0 diopters¹⁾ (default when shipped is 0 diopters).

Using an optional part allows you to modify the adjustment range to -2 to $+1$ diopters or -0.5 to $+3$ diopters.

For details, consult your Sony dealer.

Contrast and brightness adjustment

Carry out these adjustments with the color bars displayed.

- 1 Set the OUTPUT/DL/DCC+ switch to the BARS position. The color bars appear in the viewfinder.
- 2 Watching the color bars, turn the CONTRAST and BRIGHT controls to adjust the contrast and brightness.
- 3 Return the OUTPUT/DL/DCC+ switch to its original position.

Outline emphasis adjustment

Turning the PEAKING control changes the degree of outline emphasis in the viewfinder image, to make focusing easier.

1) **Diopter:** A unit to indicate the degree of convergence or divergence of a bundle of rays.



Adjusting the Lens

Flange Focal Length Adjustment

It is necessary to adjust the flange focal length (the distance from the lens flange to the plane of the image along the optical axis) in the following cases.

- When a lens is fitted for the first time
- After changing lenses
- When during zoom operations the focus does not match properly from telephoto to wide angle

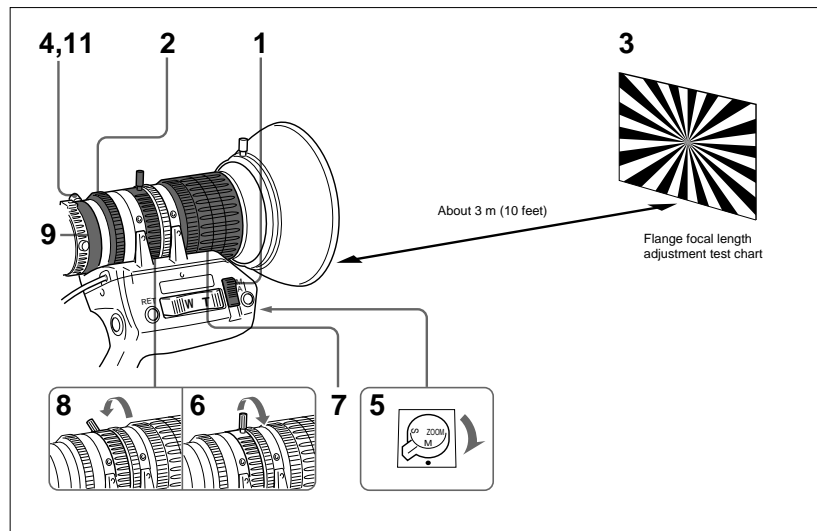

- 1 Set the iris selector to the M position.
- 2 Turn the iris ring to f/1.8 (fully open).
- 3 Place the supplied flange focal length adjustment test chart at a range of about 3 meters (10 feet), and adjust the lighting so that an appropriate video output level is obtained with the iris at f/1.8.
- 4 Loosen the screw of the Ff adjustment ring.
- 5 Set the ZOOM selector to the M position.
- 6 Move the manual zoom control to the telephoto position.
- 7 Turn the focusing ring so that the test chart is in focus.
- 8 Move the manual zoom control to the wide angle position.
- 9 Turn the Ff adjustment ring so that the test chart is in focus. Do not move the focusing ring.
- 10 Repeat steps 6 to 9 until the image stays in focus from telephoto to wide angle.
- 11 After adjustment, tighten the screw of the Ff adjustment ring.

Iris Adjustments

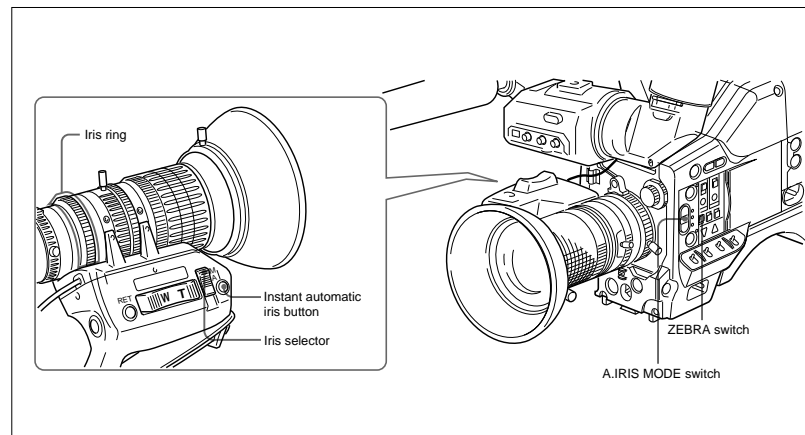

There are three ways of adjusting the iris: automatically, manually, and with the instant automatic iris adjustment function.

Iris adjustment

Adjustment method	Operation
Automatic adjustment mode The iris is adjusted automatically to adapt to changes in the brightness of the subject. This is the mode for normal shooting.	Set the iris selector to the A position.
Manual adjustment mode Use this mode in the following cases: <ul style="list-style-type: none"> • For special effects • When filming a person with a very bright sky background • When shooting a subject with extreme contrast The zebra pattern can be used as a guideline for iris adjustment.	Set the iris selector to the M position and turn the iris ring as required.
Instant automatic adjustment function While in manual adjustment mode, this function makes a temporary automatic adjustment.	With the iris selector in the M position, hold down the instant automatic iris button for as long as necessary.

To make the image lighter when shooting against the light

In the automatic iris adjustment mode, set the A.IRIS MODE switch to BACK L, turning the indicator on.

To make the image clearer when shooting a subject lit by a spotlight

In the automatic iris adjustment mode, set the A.IRIS MODE switch to SPOT L, turning the indicator on.

Using the zebra pattern in manual adjustment mode

To use the zebra pattern as a guideline for iris adjustment in manual adjustment mode, set the ZEBRA switch to the ON position. Select the zebra pattern to be displayed in advanced menu page 4 (see page 58).

- **When the subject is a person**
Adjust the iris manually so that the zebra pattern appears on the highlights of the subject's face.
- **For other subjects**
Adjust the iris manually so that the zebra pattern appears on the most important parts of the subject.

Adjusting the Lens

Macrophotography

Use the macro function when the subject is less than about 90 cm (3 feet) (for the VCL-916BYA) from the front of the lens. It is possible to shoot close-ups down to a range of 10 mm (wide angle, $f = 9$ mm).

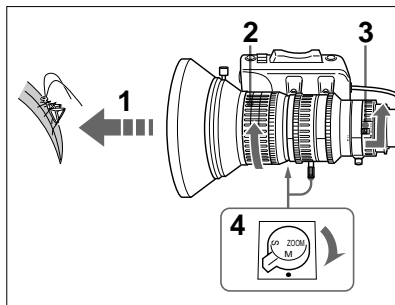

- 1** Bring the lens up to the subject so that the image is the required size.
- 2** Move the focusing ring to the closest focus position.
- 3** Slide the MACRO button toward the rear of the camera, and turn the MACRO ring fully in the direction shown by the arrow.
- 4** Move the ZOOM selector to the M position, and turn the manual zoom control to focus the image.

Ending close-up shooting

Return the MACRO ring to its original position (turn fully in the opposite direction to the arrow in the figure).

Reducing the size of the image

After completing steps **1** to **4** above, if you wish to reduce the size of the image, turn the MACRO ring back slightly, then use the manual zoom control again to focus the image.

Settings for Special Cases

Settings for special cases

Shooting conditions	Setting	Effect
The background is very bright, and the subject is too dark.	Set the A.IRIS MODE switch to BACK L, turning the indicator on.	This lightens the foreground.
The subject is under a spotlight.	Set the A.IRIS MODE switch to SPOT L, turning the indicator on.	This prevents white burn-out in highlights of faces and clothes.
The subject is completely still (e.g. when shooting documents, drawings, etc.).	Enable the EVS (Enhanced Vertical definition System) function. (See page 75.) Note Enabling the EVS function tends to increase the occurrence of aliasing problems (moiré patterns). Therefore, normally leave the function disabled.	This enhances the vertical resolution.
When you wish to give a lush effect, as when shooting a wedding or similar occasion.	Use the HISAT file. (Access advanced menu page 9 with the SET UP switch set to FILE.)	This increases the saturation of primary colors.
Shooting under fluorescent lighting.	Use the FL file. (Access advanced menu page 9 with the SET UP switch set to FILE.)	This eliminates the blue-green cast, and restores natural hues.
When shooting bright areas mixed with dark areas (Example: A person indoors looking through a window at a bright landscape outdoors)	Set DL to ON in the advanced menu page 2 and, then set the OUTPUT/DL/DCC+ switch to CAM DL.	Prevents white breakup and color faults in bright areas.
When adjusting for skin detail or tone (Example: When shooting to hide skin details)	See "Skin Detail Correction" or "Adjusting Color in the Specified Area" (page 84).	Adjusts the skin detail or tone to a designated active area.
When you wish to give pictures a natural taste created by film camera.	Use the FILMLIKE file. (Access advanced menu page 9 with the SET UP switch set to FILE.)	The "filmlike" effect is added to the picture.
To make focusing before shooting easier.	Press the EZ FOCUS button, turning the "easy focus" function on.	This opens the iris, to make it easier to focus before beginning shooting.
To begin shooting immediately when there is no time to make adjustments.	Set the EZ MODE switch to the ON position.	This provides automatic adjustment to a set of standard values, to allow immediate shooting.

Settings for Special Cases

Skin Detail Correction

The DXC-D30/D30P provides an easy push-button function that designates an active skin tone area.

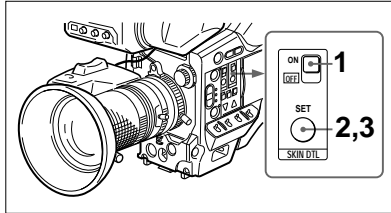

- 1 Set the SKIN DTL switch to ON.

The indication “SKIN AREA: ±0” appears in the viewfinder.

- 2 Press the SKIN DTL SET button.

This causes the area detect cursor to be shown in the viewfinder (for 10 seconds).

- 3 Place the area detect cursor on the target, then press the SKIN DTL SET button.

This designates the correction area, which is indicated by a zebra pattern, and the indication “SKIN AREA: ±0” appears again. If the area detect cursor disappears before designating the area, press the SKIN DTL SET button again to display the cursor. (Return to step 2.)

- 4 Press the UP/ON or DOWN/OFF button to change the SKIN AREA value (–99 to +99) so that the zebra pattern may be displayed in the target area. Use basic menu page 3 to set the correction level (see page 52).

You can also change color in the designated area (see the following section).

Adjusting Color in the Specified Area

You can adjust the specified color using setup files. Perform the same procedure with the skin detail correction to designate the target area.

- 1 Turn the POWER switch on with holding down the UP/ON button.
- 2 Perform steps 1 and 2 in “Changing File Settings” (page 64) and display advanced menu page 11 in the most suitable file for shooting.

```
PAGE 11 (NEXT▶ PREV◀)
FILE ADJ 2
FILE:
SAT: 33
HUE: 22
▶SKIN SAT: 12
SKIN HUE: 15
EXIT MENU (YES▶)
```

- 3 Perform the procedure for the skin detail correction to designate the area to which you apply color adjustment.

While this procedure is being performed, the menu is not displayed.

- 4 When advanced menu page 11 appears, change the value of the SKIN SAT or SKIN HUE to adjust color in the area designated in step 3.

Note

Set the SKIN DTL to 1.0 in basic menu page 3 if the skin detail correction is unnecessary.

Important Notes on Operation

Fitting the zoom lens

It is important to fit the lens correctly, as otherwise damage may result. Be sure to refer to the section “Fitting the Lens” (See page 26).

Do not cover the unit while operating

Putting a cloth, for example, over the unit can cause excessive internal heat build-up.

Operation and storage

Avoid storing or operating the unit in the following conditions.

- In excessive heat or cold (operating temperature range: –10 °C to +45 °C (14 °F to 113 °F)) Remember that in summer in warm climates the temperature inside a car with the windows closed can easily exceed 50 °C (122 °F).
- In damp or dusty locations
- Locations where the unit may be exposed to rain
- Locations subject to violent vibration
- Close to radio or TV transmitters producing strong electromagnetic fields.

Viewfinder

- Do not leave the camera with the eyepiece pointing directly at the sun. The eyepiece lens can concentrate the sun’s rays and melt the interior of the viewfinder.
- Do not use the viewfinder close to strong magnetic fields. This can cause picture distortion.

Shipping

Use the optional LC-421 Carrying Case for optimal shipping.

If sending the camera by truck, ship, air or other transportation service, first store it in the carrying case, then pack the carrying case in the supplied carton (or an equivalent).

Care of the unit

Remove dust and dirt from the surfaces of the lenses or optical filters using a blower.

If the body of the camera is dirty, clean it with a soft, dry cloth. In extreme cases, use a cloth steeped in a little neutral detergent, then wipe dry. Do not use organic solvents such as alcohol or thinners, as these may cause discoloration or other damage to the finish of the unit.

In the event of operating problems

If you should experience problems with the unit, contact your supplier or Sony service representative.

Characteristics of CCD Sensors

The following effects may appear in the image. They are characteristic of cameras using CCDs (charge-coupled devices), and do not indicate a malfunction.

Vertical smear

When shooting a very bright object, such as a light, the highlight tends to produce vertical tails. This effect is much reduced in this camera.

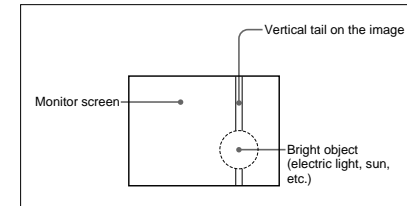

White flecks

If the camera is operated at a high temperature, white flecks may appear in the image.

Warning Indications

If a fault occurs during operation, a warning is given by the REC/TALLY and BATT indicators in the viewfinder and the tally lamp lighting or flashing, and also by warning indications on the viewfinder screen. When you are using a DSR-1/1P or PVV-3/3P, the

WARNING indicator on the VTR also lights or flashes, and warning indications appear in the display window. There is also a warning tone in the earphone.

Warning indications

Camera		VTR				Fault	VTR action	What to do
REC/TALLY indicator and tally lamp	BATT indicator	Viewfinder screen indication	WARNING indicator	Display window	Warning tone			
	—	—		RF (during recording only)		The video heads are clogged, or there is some other fault in the recording system.	The VTR emits a warning tone when it detects head clogging.	Carry out head cleaning, referring to the instruction manual for the VTR. If the problem persists after cleaning the heads, disconnect the power and consult your Sony dealer.
	—	—		SERVO		The servo lock has been lost.	Recording continues, but the recording may not be satisfactory.	Disconnect the power and consult your Sony dealer. (The SERVO indication may flash momentarily when the tape transport starts, but this does not indicate a problem.)
	—	—		HUMID	 	There is condensation.	Recording continues, but if the tape sticks to the drum, recording stops. Playback, rewind, or fast forward stops.	Stop the tape transport. Wait until the HUMID indication does not appear when you power the unit on.
	—	—		SLACK		The tape is not wound properly.	The operation stops. (Refer to the service manual or maintenance manual.)	Press the EJECT button to eject the cassette. Close the cassette compartment and check that the top panel has descended before powering off. Then consult your Sony dealer. (Do not attempt to insert any cassette.)
	—	—		TAPE (flashing, during recording only)		The tape is near the end.	Operation continues.	Change the cassette if necessary.
	—	—		TAPE (flashing)		The tape is at the end.	Recording, playback, and fast forward all stop.	Change the cassette.
		BATT 11.0V		BATT (flashing)		The battery is almost exhausted.	Operation continues.	Change the battery when possible.
		BATT 10.5V		BATT (flashing)		The battery is exhausted.	Operation continues.	Change the battery.

Continuous Flashing once per second Flashing four times per second

Four beeps per second One beep per second Continuous

For the warnings appearing in the viewfinder when a VTR is connected, see the section "Viewfinder Normal Indications" (page 47).

Y/C separate signals

Specifications

DXC-D30/D30P Camera Head

Imaging element	Three-chip interline transfer CCD
Pixel resolution	768 (horizontal) × 494 (vertical) (DXC-D30) 752 (horizontal) × 582 (vertical) (DXC-D30P)
Imaging area	8.8 × 6.6 mm (corresponds to 2/3-inch picture tube)
Built-in filter settings	1: 3200K 2: 5600K + 1/8ND 3: 5600K 4: 5600K + 1/64ND
Lens mount	Bayonet mount
Signal standards	EIA standard signal (NTSC color system) (DXC-D30) CCIR standard signal (PAL color system) (DXC-D30P)
Scanning system	525 lines, 2:1 interlace (DXC-D30) 625 lines, 2:1 interlace (DXC-D30P)
Scanning frequencies	Horizontal: 15.734 kHz (DXC-D30) 15.625 kHz (DXC-D30P) Vertical: 59.94 Hz (DXC-D30) 50.00 Hz (DXC-D30P)
Synchronization	Internal sync External sync, using signal input (VBS or BS) to the GEN LOCK IN connector of an optional camera adaptor or input from the GEN LOCK connector of a CCU-M5/M5P/M7/M7P camera control unit to the VTR/CCU/CMA connector of an optional camera adaptor.
Horizontal resolution	850 TV lines (center)
Minimum illumination	0.5 lux (at f/1.4, +36 dB) 0.8 lux (at f/1.8, +36 dB)
Sensitivity	2000 lux (f/11.0 standard, 3200 K)
Gain levels	Selectable -3 dB, 0 dB, 3 dB, 6 dB, 9 dB, 12 dB, 18 dB, 18 dB + DPR, 24 dB, 24 dB + DPR, hyper gain (30 dB + DPR)
Video output	Composite signal 1.0 Vp-p, sync negative, 75 Ω, unbalanced

Y: 1.0 Vp-p, sync negative, unbalanced
C: burst level 0.286 Vp-p, no sync

Video S/N ratio 63 dB (typical) (DXC-D30)
61 dB (typical) (DXC-D30P)
Registration 0.05% for all zones, without lens
Input/output connectors

VIDEO OUT connector: BNC, 75 Ω, unbalanced

LENS connector: 12-pin, for 2/3-inch lens

VF connector (front): 20-pin
VF connector (left side): 8-pin

REMOTE connector 1: Stereo mini-jack

REMOTE connector 2: 10-pin
MONITOR OUT connector: BNC, 75 Ω, unbalanced

Power supply 12 V DC

Power consumption 12 W (12.7 W when the DSR1/1P is connected)

Operating temperature -10 °C to +45 °C (14 °F to 113 °F)

Storage temperature -20 °C to +60 °C (-4 °F to 140 °F)

Mass 2.3 kg approx. (5 lb 1 oz)

External dimensions in millimeters (inches)

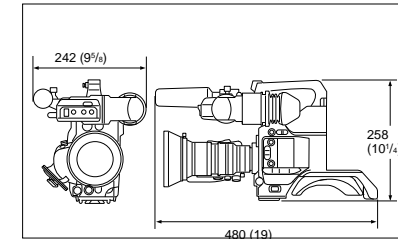

VCL-916BYA Zoom Lens

Focal length	9.0 to 144 mm
Zoom	Manual or power, selectable; zoom ratio: ×16
Maximum aperture	1:1.8
Iris	Manual or automatic, selectable; f/

Specifications

1.8 to f/16 and C (closed)	
Subject area (at 0.9 m (3 feet))	Wide angle: 815 × 611 mm (32 × 24 inches) Telephoto: 51 × 38 mm (2 × 1½ inches)
Focusing range	Infinity to 0.9 m
Filter attachment threads	77 mm dia., 0.75 mm pitch (on lens) 86 mm dia., 1 mm pitch (on lens hood)
Mounting	Sony ⅔-inch bayonet mount
Mass	1.2 kg approx. (2 lb 10 oz) (excluding lens hood)
External dimensions	120 × 197 mm (diameter × length) (4¾ × 7⅞ inches) (with lens hood, focused at infinity)

DXF-701/701CE Viewfinder

Picture tube	1.5-inch monochrome
Indicators	REC/TALLY (×2), BATT, SHUTTER, GAIN UP
Resolution	600 TV lines
Power supply	12 V DC
Power consumption	2.1 W
Mass	660 g approx. (1 lb 7 oz)
Maximum external dimensions	236 (W) × 85 (H) × 219 (D) mm (9⅜ × 3⅜ × 8⅝ inches)

Supplied accessories

VCL-916BYA Zoom Lens¹⁾ (1)
 DXF-701/701CE Viewfinder²⁾ (1)
 Microphone²⁾ (1)
 Wind screen²⁾ (1)
 VCT-U14 Tripod Adaptor²⁾ (1)
 Lens mount cap (1)
 Flange focal length adjustment test chart (1)
 Operating Instructions (1)
 ClipLink™ Guide (1)

Design and specifications are subject to change

- 1) DXC-D30F/D30K/D30PF/D30PK
2) DXC-D30F/D30K/D30L/D30PF/D30PK/D30PL

without notice.

Related Products

There is a range of Sony products available to meet every conceivable video shooting requirement. For details, consult your Sony sales representative or supplier.

Lenses

VCL-915BYA/916BY/1012BY Zoom Lens

Camera adaptor products

CA-325A/325AP/325B/327/327P/511/512³⁾/512P³⁾/
 513/537/537P Camera Adaptor
 CMA-8A/8ACE AC Adaptor
 RM-M7G Camera Remote Control Unit

VTR products

DSR-1/1P Digital Videocassette Recorder
 EVV-9000/9000P Videocassette Recorder
 PVV-1/1P/1A/1AP/3/3P Portable Videocassette
 Recorder
 VO-8800/8800P Portable Videocassette Recorder
 BVU-150/150P Portable Videocassette Recorder
 BVV-5/5PS Videocassette Recorder
 BVW-50/50P Portable Videocassette Recorder
 VA-5/5P/90/90P VTR Adaptor

Battery products

NP-1B/1A Battery Pack
 BP-90A Battery Pack
 BC-1WD/1WDCE/1WB/1WBCE/410/410CE Battery
 Charger

Microphone products

ECM-670/672 Electret Condenser Microphone
 C-74 Condenser Microphone
 CAC-12 Microphone Holder
 EC-0.5C2 Microphone Cable
 EC-0.3C2 Microphone Cable

Studio equipment

CCU-M3/M3P/M5/M5P/M7/M7P Camera Control
 Unit
 SEG-2550A/2550AP Special Effects Unit
 CRK-2000/2000P Chroma Keyer
 WEX-2000 Wipe Pattern Extender
 DXF-50B/50BCE 5-inch Viewfinder (monochrome)
 DXF-40B/40BCE 4-inch Viewfinder (monochrome)
 DR-100 Intercom Headset
 RMM-1800 Rack Mounting Kit

Cables and miscellaneous

The suffix number on a cable part number indicates the length in meters: e.g. a CCZ-A2 is 2 meters long.
 (Approximate equivalents in feet: 2 m = 6 ft, 5 m = 16 ft, 10 m = 33 ft, 25 m = 82 ft, 50 m = 164 ft, 100 m = 328 ft)
 Camera cables with Z-type 26-pin connectors
 CCZ-A2/A5/A10/A25/A50/A100
 Camera cables with Q-type 14-pin connectors
 CCZQ-A2/A5/A10/A2AM
 CCZZ-1B/1E Cable Extension Connector
 Camera cables with Q-type 14-pin connectors
 CCQ-2BRS/5BRS/10BRS
 CCQ-10AM/25AM/50AM/100AM
 CCZJ-2 Camera Cable with Z-type 26-pin connector
 and J-type 10-pin connector
 LC-421 Carrying Case
 LCR-1 Rain Cover
 CAC-4 Chest Pad
 LC-304SFT Soft Case



Chart of Optional Components and Accessories

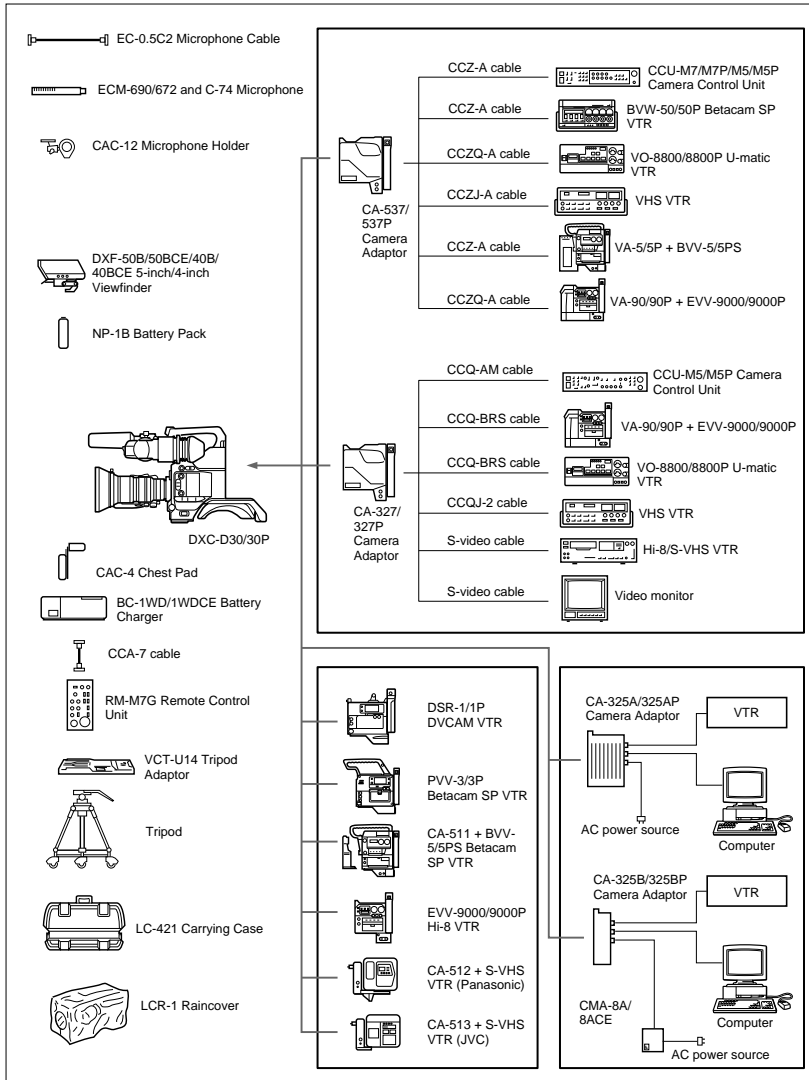

Appendix

SECTION 2

SERVICE INFORMATION

2-1. BOARD LAYOUT

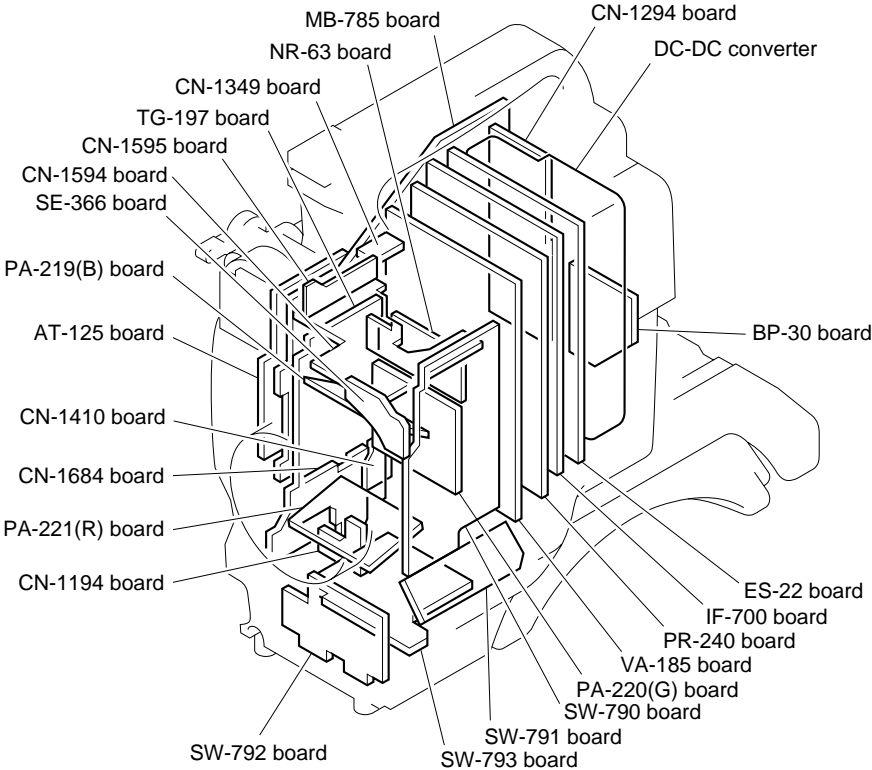

2-2. REMOVAL OF CABINET

2-2-1. Removal of Side Plate

Loosen the four screws respectively to remove the side plates.

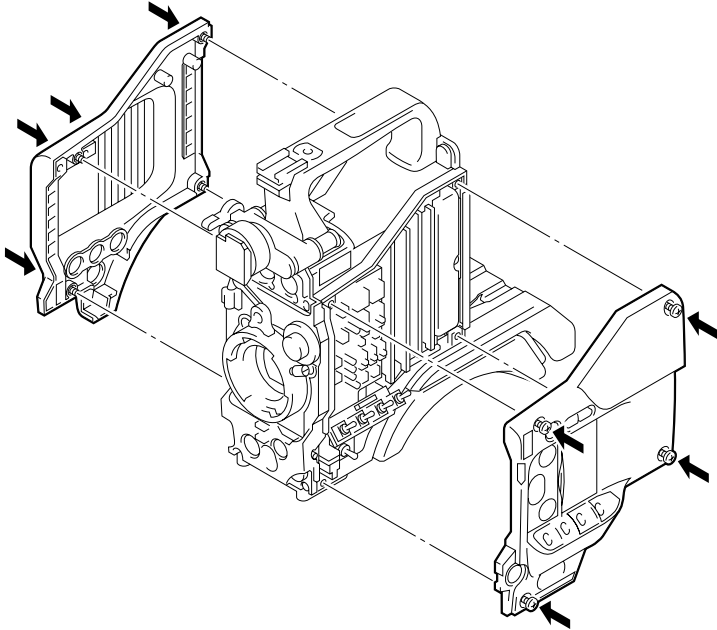

CAUTION

2-2-2. Cautions on Disassembly/Assembly of Top Chassis

When removing the top chassis, following items should be performed. If not, the connectors (CN503, CN504, CN505) should be damaged.

Disassembly:

1. Disconnect the two connectors CN504 and CN505 on the CN-1594 board.
2. Remove the MB-785 board in the horizontal direction. Because, not to break the connectors.

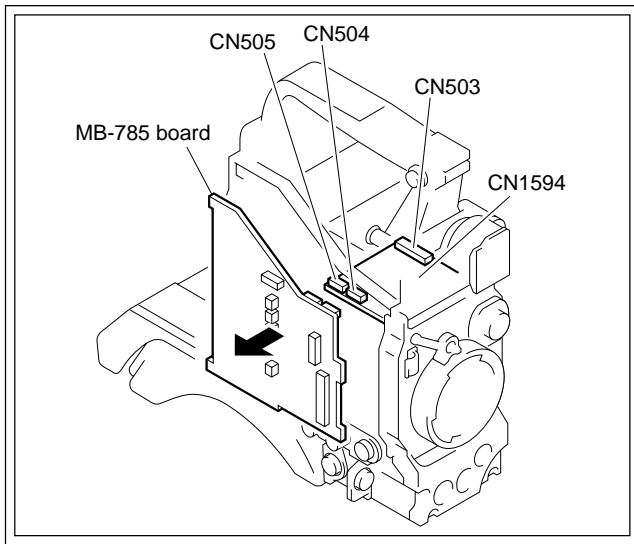

3. Disconnect the connector CN503.
4. Remove the SW-790 board.

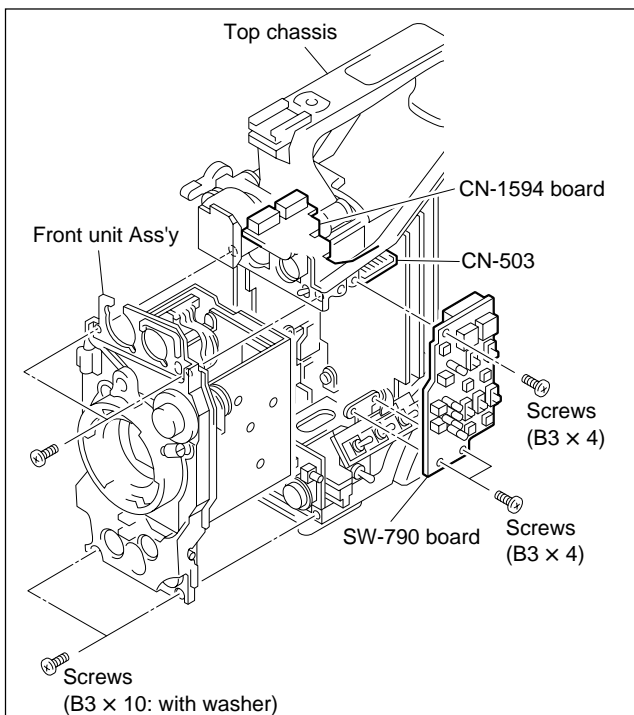

Assembly:

1. Insert the partition to the rail of the upper board rail.

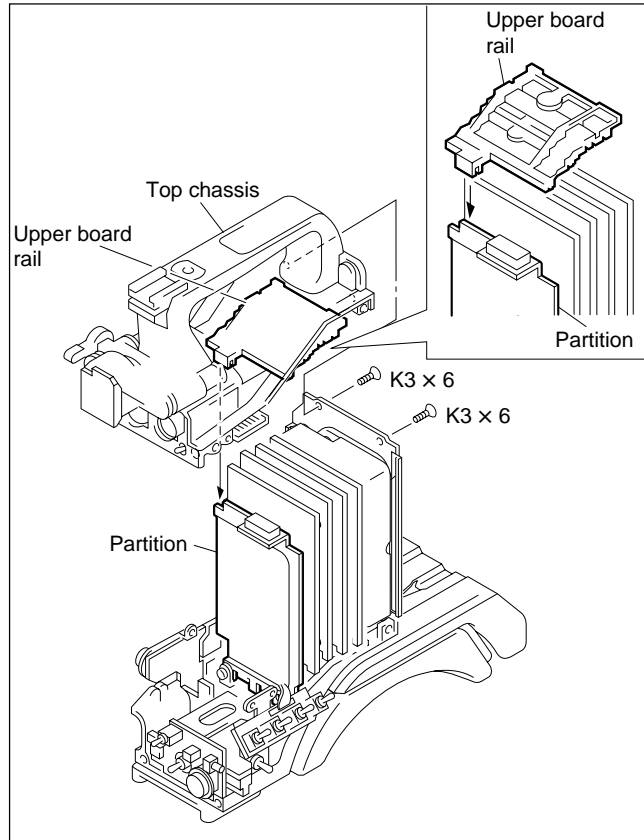

2. After assembling the top chassis, assemble the front unit Ass'y.

2-3. REPLACEMENT OF MAIN PARTS

2-3-1. Replacement of CCD Unit

1. Remove the lens and viewfinder referring to the instruction manual.

Note: Attach a mount cap to the lens mount to protect the prism block.

2. Remove the left side plate referring to Section 2-2-1. "Removal of Side Plate".
3. Remove two screws as shown in Figure. Remove the AT-125 board. Disconnect the five connectors CN2, CN105, CN106, CN107 and CN123 on the MB-785 board.

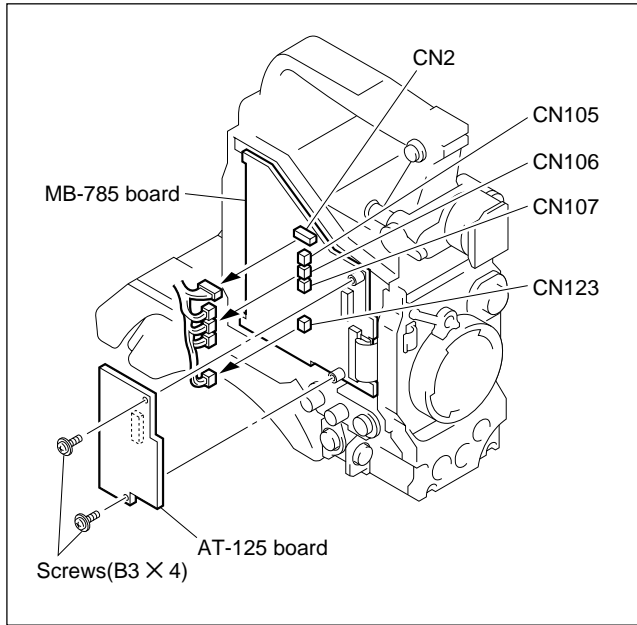

4. Remove four screws (B3 × 10 : with washer). Disconnect the two connectors, CN2 and CN14 on the MB-785 board. Pull out the Front unit Ass'y.

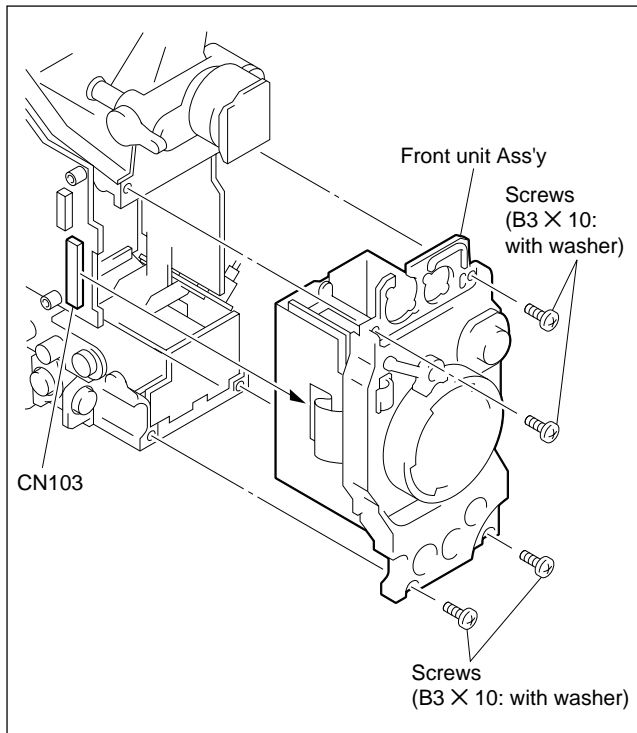

5. Remove setscrew (3 × 4) and remove the filter knob. Remove four screws (B3 × 8) and washers. Remove the CCD unit from the Front unit Ass'y.

Note: When handling the CCD unit, pay attention not to stress each PA board.

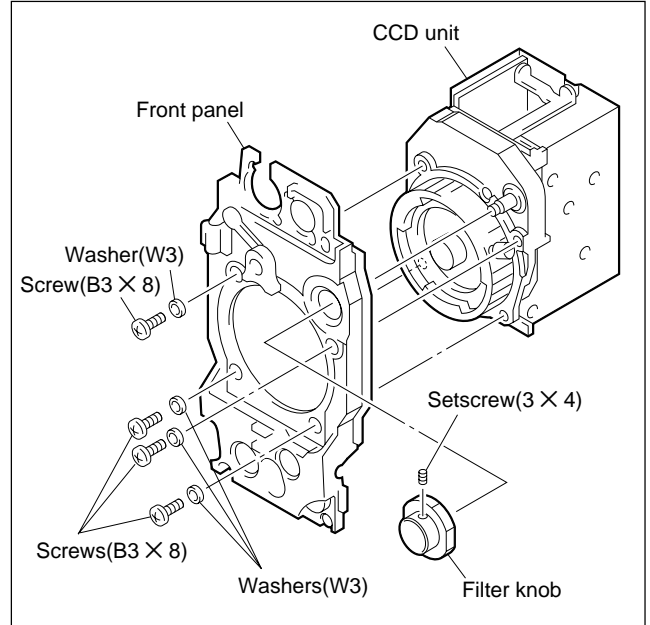

6. Remove the CCD unit from transport holder for replacement CCD unit supplied from the Sony Part Center. When installing a new CCD unit, reverse the above procedures. After the replacement is complete, perform several adjustments referring to Section 3-1-4. "Note on Adjustment".

Note: When transporting the CCD unit that was removed from the unit, reuse the transport holder.

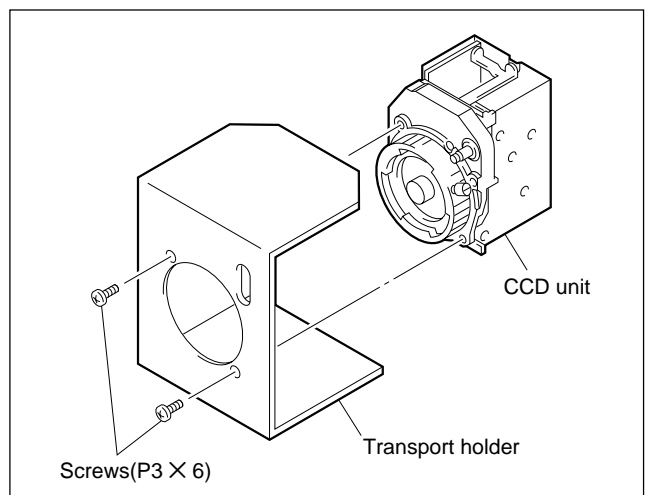

2-4. CONNECTORS AND CABLES

2-4-1. Connector Input/Output Signals

The main connector input/output signals are as follows:

MONITOR OUT (JACK); 1.0 Vp-p ± 0.1 V, sync negative 75 Ω

VIDEO OUT (BNC); 1.0 Vp-p ± 0.1 V, sync negative 75 Ω

CAMERA/CA (50P, MALE)

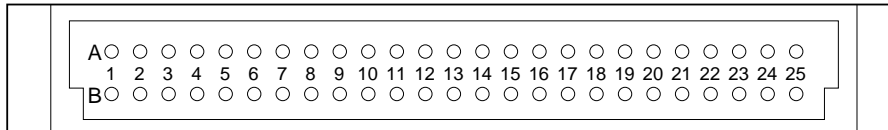

(EXTERNAL VIEW)

Pin No.	Signal	Specification
A1	MODE ID IN	OPEN : COMP, GND: R/G/B
B1	GND (CHASSIS)	
A2	MIC (Y) OUT	-60 dBm
B2	MIC (X) OUT	
A3	MIC (G) OUT	
B3	EAR (G) IN	
A4	REC TALLY IND IN	$Z_i \geq 600 \Omega$
B4	EAR (X) IN	-6 dBu
A5	VTR TRIG OUT	
B5	REC RESET IN	
A6	S.D (V/C) IN	H : 5 V
B6	S.D (V/C) OUT	L : 0 ± 0.5 V
A7	CS VTR IN	$Z_i \geq 47 \text{ k}\Omega$
B7	SCL VTR IN	$Z_o \leq 1 \text{ k}\Omega$
A8	GENLOCK VIDEO (G) IN	VBS : 1.0 Vp-p
B8	GENLOCK VIDEO (X) IN	$Z_i \geq 1 \text{ k}\Omega$
A9	SYNC (G) OUT	H : 4.0 to 5.5 Vp-p : NEGATIVE
B9	SYNC (X) OUT	L : 0 ± 0.4 Vdc $Z_o \leq 2 \text{ k}\Omega$
A10	PB RET VIDEO (G) IN	1.0 Vp-p
B10	PB RET VIDEO (X) IN	$Z_i \geq 10 \text{ k}\Omega$
A11	CF/V RESET I/O	H : 4.0 to 5.5 Vp-p $Z_o \leq 2 \text{ k}\Omega$ L : 0 ± 0.4 Vdc
B11	VF VIDEO CONT IN	CAM : OPEN $Z_i \geq 1 \text{ k}\Omega$, PB : 0 V
A12	VBS (CA) (G) OUT	1.0 Vp-p, SYNC NEGATIVE
B12	VBS (CA) (X) OUT	$Z_o = 75 \Omega \pm 5 \%$
A13	STBY/SAVE OUT	STBY: 4.0 to 5.5 Vp-p $Z_o \leq 100 \Omega$ SAVE : 0 ± 0.25 V
B13	VTR/CCU CONT OUT	VTR : 0 ± 0.25 V $Z_o \leq 1 \text{ k}\Omega$ CCU : 5.0 ± 0.5 V
A14	CHROMA (G) OUT	NTSC : 0.286 Vp-p $\pm 10 \%$
B14	CHROMA (X) OUT	PAL : 0.300 Vp-p $\pm 10 \%$ $Z_o \leq 75 \Omega \pm 5 \%$

Pin No.	Signal	Specification
A15	Y (G) OUT	1.0 Vp-p, SYNC NEGATIVE
B15	Y (X) OUT	$Z_o \leq 75 \Omega \pm 5 \%$
A16	COMP (CA) GND	R/G/B
B16	R/R-Y (CA) OUT	1.4 Vp-p, POSITIVE
A17	G/Y (CA) OUT	$Z_o \leq 75 \Omega \pm 5 \%$
B17	B/B-Y (CA) OUT	COMPONENT OUT *1
A18	BATT ALARM/S. DATA	
B18	REC REVIEW CONT OUT	GND; REC REVIEW
A19	(SPARE)	
B19	(SPARE)	
A20	+8.5 V OUT 9.0 V	8.3 V to 9.1 V
B20	+5 V OUT	± 0.1 V
A21	-5 V OUT	
B21	AGND	REG, GND
A22	POWER +12 V DC IN	10.6 V to 17.0 Vdc
B22	POWER +12 V DC IN	
A23	POWER +12 V DC GND	GND for ± 12 Vdc
B23	POWER +12 V DC GND	
A24	(SPARE)	
B24	(SPARE)	
A25	GND (CHASSIS)	CHASSIS GND
B25	GND (CHASSIS)	

*1

	UC	CE
Y	0.714 Vp-p	0.700 Vp-p
R-Y	0.756 Vp-p	0.525 Vp-p
B-Y	0.756 Vp-p	0.525 Vp-p

CAMERA/CA (76P, MALE)

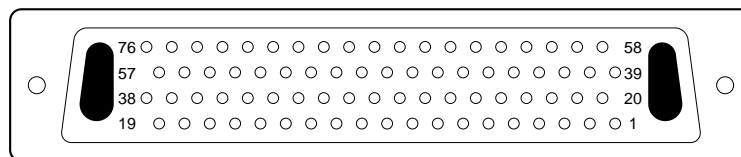

(EXTERNAL VIEW)

Pin No.	Signal	Specification	Pin No.	Signal	Specification
1	REC TALLY IN	$Z_i \geq 600 \Omega$	27	VBS (CA) (X) OUT	1.0 Vp-p, SYNC NEGATIVE $Z_o = 75 \Omega \pm 5 \%$
2	S.D. (V/D) IN	H : 5 V L : 0 ± 0.5 V	28	C (G) OUT	NTSC : 0.286 Vp-p $\pm 10 \%$ PAL : 0.300 Vp-p $\pm 10 \%$ $Z_o \leq 75 \Omega \pm 5 \%$
3	SCL VTR IN	$Z_i \geq 47 \text{ k}\Omega$ $Z_o \leq 1 \text{ k}\Omega$	29	Y (G) OUT	1.0 Vp-p, SYNC NEGATIVE $Z_o \leq 75 \Omega \pm 5 \%$
4	GENLOCK (G) IN	VBS : 1.0 Vp-p $Z_i \geq 1 \text{ k}\Omega$	30	COMP GND	R/G/B 1.4 Vp-p, POSITIVE
5	SYNC (G) IN	H : 4.0 to 5.5 Vp-p : NEGATIVE L : 0 ± 0.4 Vdc $Z_o \leq 2 \text{ k}\Omega$	31	G/Y (CA) OUT	$Z_o \leq 75 \Omega \pm 5 \%$ COMPONENT OUT *1
6	PB (G) IN	1.0 Vp-p $Z_i \geq 10 \text{ k}\Omega$	32	BATT S.DATA IN	
7	PB (Y) (X) IN	1.0 Vp-p, NEGATIVE, $Z_i \geq 1 \text{ k}\Omega$	33	+9.0 V OUT	8.3 V to 9.1 V
8	VBS (CA) (G) OUT	1.0 Vp-p, SYNC NEGATIVE $Z_o = 75 \Omega \pm 5 \%$	34	-5.0 V OUT	± 0.1 V
9	VTR/CCU OUT	VTR : 0 ± 0.25 V, $Z_o \leq 1 \text{ k}\Omega$ CCU : 5.0 ± 0.5 V	35	EXT DC IN	10.6 V to 17.0 Vdc
10	C (X) OUT	NTSC : 0.286 Vp-p $\pm 10 \%$ PAL : 0.300 Vp-p $\pm 10 \%$ $Z_o \leq 75 \Omega \pm 5 \%$	36	EXT DC GND	GND for ± 12 Vdc
11	Y (X) OUT	1.0 Vp-p, SYNC NEGATIVE $Z_o \leq 75 \Omega \pm 5 \%$	37	DCF OUT	
12	R/R-Y (CA) OUT	R/G/B 1.4 Vp-p, POSITIVE	38	DCLK GND	
13	B/B-Y (CA) OUT	$Z_o \leq 75 \Omega \pm 5 \%$ COMPONENT OUT *1	39	MODE ID IN	
14	SKIN GATE OUT	Gate area (H: 4 to 5.5 Vdc) Non gate area (L: 0 ± 0.2 Vdc)	40	MIC1 (G) OUT	OPEN : COMP, GND: R/G/B
15	+5.0V OUT	± 0.1 V	41	AUDIO LEV OUT	H : 4 to 5.5 Vdc L : 0 ± 0.2 Vdc, 1 k Ω
16	AGND	REG, GND	42	(SPARE)	
17	EXT DC IN	10.6 V to 17.0 Vdc	43	DIGI/ANA IN	H : Analog L : Digital
18	EXT DC GND	GND for ± 12 Vdc	44	(SPARE)	
19	DCLK (X) OUT		45	(SPARE)	
20	VTR TRIG OUT		46	(SPARE)	
21	S.D. (C/V) OUT	H : 5 V L : 0 ± 0.5 V	47	(SPARE)	
22	CS VTR IN	$Z_i \geq 47 \text{ k}\Omega$ $Z_o \leq 1 \text{ k}\Omega$	48	(SPARE)	
23	GENLOCK (X) IN	$Z_i \geq 1 \text{ k}\Omega$	49	(SPARE)	
24	SYNC (X) IN	H : 4.0 to 5.5 Vp-p : NEGATIVE L : 0 ± 0.4 Vdc $Z_o \leq 2 \text{ k}\Omega$	50	(SPARE)	
25	PB (VBS) (X) IN	$Z_i \geq 10 \text{ k}\Omega$	51	(SPARE)	
26	CF/V RESET I/O	H : 4.0 to 5.5 Vp-p $Z_o \leq 2 \text{ k}\Omega$ L : 0 ± 0.4 Vdc	52	DCLK GND	H : 3 ± 0.2 Vdc L : 0 ± 0.2 Vdc
			53	BYRY (0) OUT	
			54	BYRY (2) OUT	
			55	BYRY (4) OUT	
			56	BYRY (6) OUT	
			57	BYRY (8) OUT	
			58	MIC1 (X) OUT	-20 dBm, $Z_o \leq 100 \Omega$
			59	MIC1 (Y) OUT	

REMOTE (10P, FEMALE)

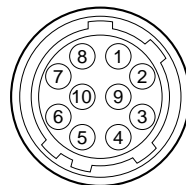

(EXTERNAL VIEW)

Pin No.	Signal	Specification
60	(SPARE)	
61	(SPARE)	
62	76P ID	
63	(SPARE)	
64	(SPARE)	
65	(SPARE)	
66	(SPARE)	
67	(SPARE)	
68	(SPARE)	
69	(SPARE)	
70	(SPARE)	
71	(SPARE)	
72	BYRY (1) OUT	H : 3 ± 0.2 Vdc
73	BYRY (3) OUT	L : 0 ± 0.2 Vdc
74	BYRY (5) OUT	
75	BYRY (7) OUT	
76	BYRY (9) OUT	

Pin No.	Signal	Specification
1	(SPARE)	
2	VBS (RM) (X)	1.0 Vp-p, SYNC NEGATIVE
3	VBS (RM) (G)	
4	RS232C (C/RM) IN	
5	VTR START/STOP IN	$Z_i \geq 10 \text{ k}\Omega$ OPEN (4.5 ± 0.5 V) 0 ± 0.5 V
6	S. DATA (X)	0 to 5 V $Z_i \geq 10 \text{ k}\Omega$
7	RS232C (RM/C) IN	GND for S. DATA
8	REC TALLY IND OUT	$Z_o \geq 600 \Omega$
9	POWER +12 V DC GND	GND for +12 Vdc
10	POWER +12 V DC OUT	10.6 V to 17.0 Vdc

VF (8P, FEMALE)

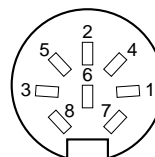

(WIRING SIDE)

*1

	UC	CE
Y	0.714 Vp-p	0.700 Vp-p
R-Y	0.756 Vp-p	0.525 Vp-p
B-Y	0.756 Vp-p	0.525 Vp-p

Pin No.	Signal	Specification
1	POWER +12 V DC GND	GND for +12 Vdc
2	REC TALLY IND OUT	$Z_o \leq 1.1 \text{ k}\Omega$
3	SHUTTER IND OUT	$Z_o \leq 1.1 \text{ k}\Omega$
4	VF VIDEO (G) OUT	GND for VF VIDEO
5	BATT IND OUT	$Z_o \leq 1.1 \text{ k}\Omega$
6	VF VIDEO (X) OUT	$V = 1$ Vp-p
7	POWER +12 V DC OUT	10.6 V to 17.0 Vdc
8	GAIN UP IND OUT	$Z_o \leq 1.1 \text{ k}\Omega$

LENS (12P, FEMALE)

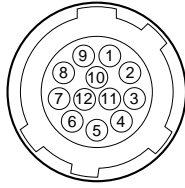

(EXTERNAL VIEW)

Pin No.	Signal	Specification
1	RET SW-IN	ON : 0 ± 0.5 Vdc
2	VTR START/STOP IN	TRIG : 0 ± 0.5 V
3	POWER +12 V DC GND	GND for + 12 Vdc
4	COMPULSORY AUTO IRIS CONT OUT	AUTO : 4.5 ± 0.5 V MANU : $0 + 0.5$ V or OPEN
5	IRIS CONT OUT	F16 : 3.4 Vdc F2.8 : 6.2 Vdc
6	POWER +12 V DC OUT	10.6 V to 17.0 Vdc
7	IRIS POSI IN	F16 : 3.4 ± 0.1 Vdc F2.8 : 6.2 ± 0.1 Vdc
8	REMOTE/LOCAL OUT	REMOTE : 5 V LOCAL : 0 V
9	EXTND ON/OFF IN	
10	ZOOM POSI IN	
11	(SPARE)	
12	(SPARE)	

MIC (3P, FEMALE)

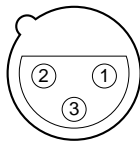

(EXTERNAL VIEW)

Pin No.	Signal	Specification
1	MIC (G) IN	GND for MIC
2	MIC (X) IN	-60 dB BALANCED
3	MIC (Y) IN	(0 dB = 0.775 V)

VF (20P, FEMALE)

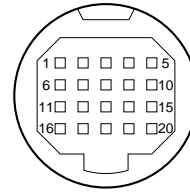

(EXTERNAL VIEW)

Pin No.	Signal	Specification
1	PEAKING CONT IN	$Z_i \geq 5$ k Ω
2	SWD EXT DC OUT	10.5 V to 17.0 Vdc, 2 A
3	REC TALLY IND OUT	$Z_o \leq 500$ Ω
4	BATT IND OUT	$Z_o \leq 1.1$ k Ω
5	ZEBRA SW IN	ON : 0 ± 0.5 V
6	VF VIDEO (X) OUT	$V = 1.0$ Vp-p
7	SWD EXT DC OUT	10.5 V to 17.0 Vdc, 2 A
8	(SPARE)	
9	(SPARE)	
10	SDA (VF) OUT	$Z_o \leq 500$ Ω , 5 Vp-p
11	VF VIDEO (G) OUT	GND for VF VIDEO
12	EXT DC GND	GND for EXIT DC
13	(SPARE)	
14	(SPARE)	
15	SCL (VF) OUT	$Z_o \leq 500$ Ω , 5 Vp-p
16	R-Y (VF) OUT	$V = 830$ mV
17	EXT DC GND	GND for EXIT DC
18	B-Y (VF) OUT	$V = 830$ mV
19	SYNC (VF) OUT	$V = 5$ Vp-p
20	LD (VF) OUT	$Z_o \leq 500$ Ω , 5 Vp-p

2-4-2. Connection Connector

Connections made with the connector panels during installation or service, should be made with the connectors or complete cable assemblies specified in the following list, or equivalent parts.

Connector Name	Parts No. and name of connector with cable
REMOTE (10P, FEMALE)	1-506-522-11 CONNECTOR, ROUND 10P, MALE HIROSE HR 10A-10P-10P equality or CCA-7-20 Cable assembly (optional)
VIDEO OUT (BNC)	1-560-661-11 PLUG, BNC
VF (8P, FEMALE)	9-994-797-01 CABLE, VF
LENS (12P, FEMALE)	1-564-360-11 CONNECTOR, 12P, MALE HIROSE HR 10-10PA-12P equality
MIC (3P, FEMALE)	1-508-084-31 CONNECTOR, 3P, MALE CANNON XLA-3-12C equality
VF (20P, FEMALE)	1-778-661-11 CONNECTOR, 20P, MALE HIROSE HR 12-14PA-20PC equality

2-5. HOW TO HANDLE OF AT-125 BOARD

2-5-1. How to Attach of the Extension Board EX-591

When using the extension board EX-591, attach as follows.

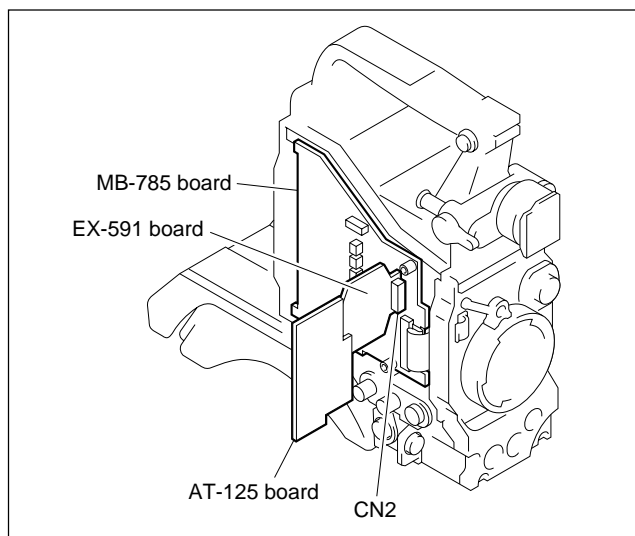

2-5-2. Replacement Way of ROM(IC102)

Note: When replacing the ROM, it is need that each menu is reset.

1. Slide the IC Socket cover in the A-arrow direction until the click is heard. Remove the IC socket cover and the former ROM.
2. Attach the new ROM on the IC socket.
3. Place the IC socket cover to have the clearance between ROM and A-arrow side of IC socket cover. (Refer to Fig.1.)
4. Slide the IC Socket cover in the opposite A-arrow direction with holding the ROM.

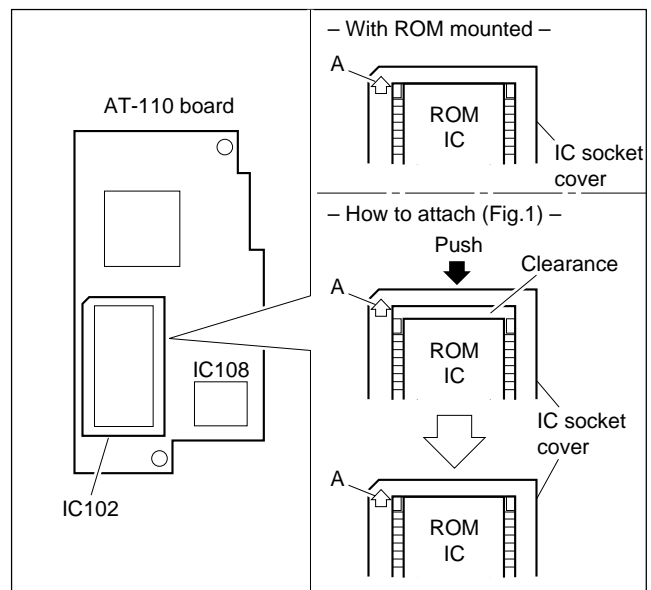

2-6. DC-DC CONVERTER VOLTAGE

Voltage values can be check as following ① to ⑫ points on MB-785 board and MIC connector.

• MB-785 board

• MIC connector

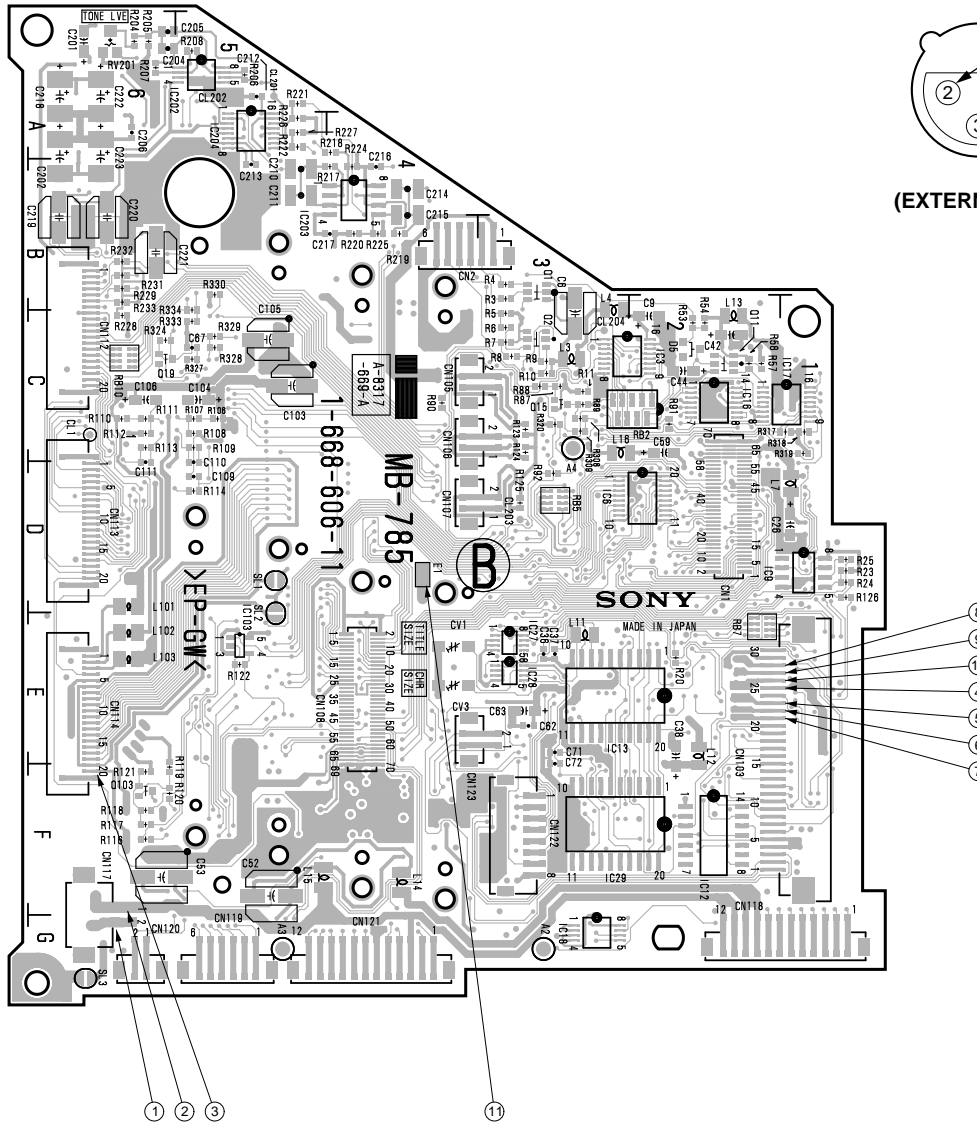

No.	CHECK POINT	VOLTAGE VALUE
①	CN117-2pin	5WD EXT. DC OUT
②	CN117-1pin	EXT. DC GND
③	CN114-20pin	+3.1 V
④	CN103-25pin	+5.3 V
⑤	CN103-23pin	-5 V
⑥	CN103-22pin	+9 V

No.	CHECK POINT	VOLTAGE VALUE
⑦	CN103-21pin	-10 V
⑧	CN103-28pin	+6.5 V
⑨	CN103-27pin	+16 V
⑩	CN103-26pin	+32 V
⑪	E1(GND)	---
⑫	MIC 2pin/1pin(GND)	+48 V

2-7. SERVICE MODE OPERATION

- **SERVICE mode:**

Commonly, user can operate the BASIC menu and ADVANCE menu. In addition to these menu, service engineer can operate the SERVICE menu.

To enter the service mode by adjusting S105 (OPE↔ADJ) on the SW-791 board.

- **Menu screen:**

When the S105 on the SW-791 board is set to ADJ, following menu select screen is appeared.

Menu select screen

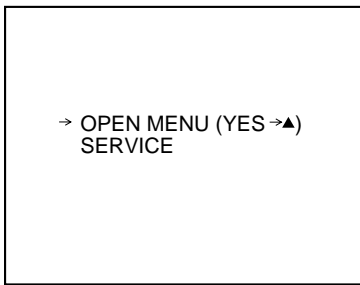

Move the cursor to menu item by STATUS / MENU switch, select the menu by UP ▲ switch or DOWN ▼ switch. (The menu is cyclically changed to SERVICE ↔ BASIC ↔ ADVANCE ↔ SERVICE.) To enter the "SERVICE" menu, perform as follows.

- ① Select the "SERVICE" by UP ▲ switch or DOWN ▼ switch.
- ② Move the cursor to "OPEN MENU (yes→▲)" by STATUS / MENU switch.
- ③ Push the UP ▲ switch. Then, the "Page" of menu is displayed.

After performing the page of each menu, normally, the operation is performed the menu. When quitting the each menu, the screen is returned to the Menu Select Screen.

- **Connection:**

The menu screen is ensured by seen the viewfinder or MONITOR OUT of DXC-D30WS (for NTSC) or DXC-D30WSP (for PAL).

• **RESET object item and standard set value for setting (Table 1)**

PAGE	ITEM	Standard set value	
		UC	PAL
4	MPKNEE1	67	←
	MPKNEE2	116	←
	MPKNEE3	164	←
	MPKNEE4	255	←
	RPKNEE	128	←
	BPKNEE	128	←
9 (NTSC)	SET UP	ON	---
	RESD OUT	FD	---
	BLKG	20	---
	MAT DEST	SMPTE	---
9 (PAL)	COMP LVL	---	525
	READ OUT	---	FD
13	GAMMA	ON	←
	MATRIX	ON	←
	DTL	ON	←
	APT	ON	←
	YWCLP	255	←
	IRIS GAIN	200	←
14	R TTL	75	←
	G TTL	75	←
	B TTL	75	←
	R TTLB	0	←
	G TTLB	0	←
	B TTLB	0	←
15	LL ADJ	120	154
	PKAVECOM	100	←
	IRISMARK	144	←
	MGAM ADJ	132	132
	RGAM ADJ	±0	←
	BGAM ADJ	±0	←
	MBLK ADJ	2068	2070
16	R.KNEE S	±0	←
	B.KNEE S	±0	←
	R.KNEE P	±0	←
	B.KNEE P	±0	←
17	FILTER	2	2

• **Page 1 RESET**

(for NTSC)

```

->PAGE 1 (NEXT->▼ PREV->▲)

RESET
  (YES->▲)
DEST : UC

EXIT MENU (YES->▲)
    
```

(for PAL)

```

->PAGE 1 (NEXT->▼ PREV->▲)

RESET
  (YES->▲)

EXIT MENU (YES->▲)
    
```

The "RESET" mode is set to standard set value except each board adjustment values or differential adjustment values by each unit. (Refer to table 1.)

* In the NTSC, move the cursor to "DEST", select UC, then move the cursor to "RESET", and push UP ▲ switch.

• **Page 2 Standing Correction**

```

PAGE 2 (NEXT->▼ PREV->▲)

A SHAD
  (YES->▲)
R SHAD : 118
G SHAD : 135
B SHAD : 123

EXIT MENU (YES->▲)
    
```

A SHAD (This is not functioned.)

R SHAD / G SHAD / B SHAD

Stading correction of V

Standard (correction 0) = 128

Shoot the white portion of pattern box, adjust the UP ▲ switch or DOWN ▼ switch so that the waveform is flat on the oscilloscope with VD period.

VA-185 board

Test point

CL101 (Rch)

CL201 (Gch)

CL301 (Bch)

• **Page 3 Flare Adjustment**

```

PAGE 3 (NEXT->▼ PREV->▲)

R FLARE : 0
G FLARE : 0
B FLARE : 0

EXIT MENU (YES->▲)
    
```

R FLARE / G FLARE / B FLARE

Flare correction

(Not corrected at 0)

Regarding the adjustment, see the "SECTION 3 ALIGNMENT."

• **Page 4 Pre Knee Setting**

```

PAGE 4 (NEXT->▼ PREV->▲)

MPKNEE 1 : 67
MPKNEE 2 : 116
MPKNEE 3 : 164
MPKNEE 4 : 255
RPKNEE   : 128
BPKNEE   : 128

EXIT MENU (YES->▲)
    
```

		Standard value
MPKNEE1	Usual Master Pre Knee Point (D range 600 %)	: 67
MPKNEE2	Master Pre Knee point at -3dB gain (D range 425 %)	: 116
MPKNEE3	Master Pre Knee point at FM mode (D range 300 %)	: 164
MPKNEE4	Master Pre Knee point at -3dB gain and FM mode (D range 212 %)	: 255
RPKNEE	Rch Pre Knee Point fine Adjustment	: 128
BPKNEE	Rch Pre Knee Point fine Adjustment	: 128

• Page 5 Component Level Adjustment

PAGE 5 (NEXT→▼ PREV→▲)	
W Y LVL	: 167
W R-Y LVL	: 152
W B-Y LVL	: 154
Y LVL	: 167
R-Y LVL	: 152
B-Y LVL	: 154
SYNC LVL	: 96
S-UP LVL	: 144
EXIT MENU (YES→▲)	

- Set the camera main unit to color-bar mode and perform the following adjustments. Use an extension (EX) board to IF-700 board.

		Measurement Point
W Y LVL	Level adjustment of Y (16:9)	EX board : TP-61
W R-Y LVL	Level adjustment of R-Y (16:9)	EX board : TP-60
W B-Y LVL	Level adjustment of B-Y (16:9)	EX board : TP-62
Y LVL	Level adjustment of Y (4:3)	EX board : TP-61
R-Y LVL	Level adjustment of R-Y (4:3)	EX board : TP-60
B-Y LVL	Level adjustment of B-Y (4:3)	EX board : TP-62
SYNC LVL	Level adjustment of SYNC	EX board : TP-61
S-UP LVL	Level adjustment of SETUP	EX board : TP-61

The adjustment is available when the unit is setup ON in the NTSC mode.

• Page 6 CLP Level Adjustment

PAGE 6 (NEXT→▼ PREV→▲)	
Y CLP	: 143
R-Y CLP	: 107
B-Y CLP	: 110
EXIT MENU (YES→▲)	

- Set the camera main unit to color-bar mode and perform the following adjustments. Use an extension (EX) board to IF-700 board.

		Measurement Point
Y CLP	CLP Level adjustment of Y	EX board : TP-61
R-Y CLP	CLP Level adjustment of R-Y	EX board : TP-60
B-Y CLP	CLP Level adjustment of B-Y	EX board : TP-62

• Page 7 Chroma/VF Adjustment

PAGE 7 (NEXT→▼ PREV→▲)	
R-Y C/B	: 108
R-Y BST	: 0
B-Y C/B	: 103
B-Y BST	: 77
VF SYNC	: 142
VF BLKG	: 105
EXIT MENU (YES→▲)	

- Set the camera main unit to color-bar mode and perform the following adjustments. Use an extension (EX) board to ES-22 board.

		Measurement Point
R-Y C/B	Carrier balance adjustment of R-Y	VBS OUT
R-Y BST	Burst level adjustment of R-Y direction	VBS OUT
B-Y C/B	Carrier balance adjustment of B-Y	VBS OUT
B-Y BST	Burst level adjustment of B-Y direction	VBS OUT
VF SYNC	Sync level adjustment of VF video	EX board : TP-82
VF BLKG	BLKG level adjustment of VF video	EX board : TP-82

• Page 8 SC adjustment

PAGE 8 (NEXT→▼ PREV→▲)	
SC FREQ	: 2278
SC-H	: 1104
EXIT MENU (YES→▲)	

		Measurement Point
SC FREQ	SC frequency adjustment	ES board : TP-501
SC-H	SC-H adjustment	VBS OUT

• **Page 9 Various kinds items setting 1**

(for NTSC)

```

PAGE 9 (NEXT→▼ PREV→▲)

SETUP      : ON
READ OUT:  FD
V BLKG     : 20H
MAT DEST:  SMPTE

EXIT MENU (YES→▲)
    
```

(for PAL)

```

PAGE 9 (NEXT→▼ PREV→▲)

COMP LVL:  525
READ OUT:  FD

EXIT MENU (YES→▲)
    
```

(for NTSC)

SETUP	ON / OFF of SETUP	: ON
READOUT	FD reading out / FM reading out change	: FD
V BLKG	BLKG width setting (19/20/21H)	: 20H
MAT DEST	Matrix destination setting (EBU/SMPTE)	: SMPTE

(for PAL)

COMP LVL	Color differential output	
	525 / 700 change	:525
READOUT	FD reading out / FM reading out change	:FD

• **Page 10 TEST MODE**

```

PAGE10(NEXT→▼ PREV→▲)

TEST      : OFF
R-Y       : ON
B-Y       : ON

EXIT MENU (YES→▲)
    
```

```

TEST      ON / OFF of TEST SAW
          TEST:1  TEST SAW of 100 %
          TEST:2  TEST SAW of 226 %
          TEST:3  TEST SAW of 226 % at lower side of screen
R-Y       ON / OFF of R-Y output
B-Y       ON / OFF of B-Y output
    
```

• **Page 11 HEAD BLOCK No. information**

```

PAGE11(NEXT→▼ PREV→▲)

HEAD 1   : G
HEAD 2   : V
HEAD 3   : 0
HEAD 4   : 0
HEAD 5   : 0
HEAD 6   : 4
HEAD 7   : 6

EXIT MENU (YES→▲)
    
```

HEAD 1 ~ 7 BLOCK No.

When replacing the TG-197 board or EEPROM (IC1) on the TG-197 board, input the BLOCK No. label which is put on the side of the CCD UNIT.

Input method: The BLOCK No. is inputted by UP ▲ switch or DOWN ▼ switch.

• **Page 12 RG, SUB communication**

```

PAGE12(NEXT→▼ PREV→▲)

R RG      : 21
G RG      : 74
B RG      : 21
R SUB     : 78
G SUB     : 85
B SUB     : 78
TPC       : +30

EXIT MENU (YES→▲)
    
```

Note : This value is changed by each unit. The numerical value is not changed. According to this, when replacing the TG-197 board or EEPROM (IC1) on the TG-197 board, the reset is needed. Contact your authorized Sony dealer.

• Page 13 Various items setting 2

```

PAGE13(NEXT→▼ PREV→▲)
GAMMA : ON
MATRIX : ON
DTL : ON
APT : ON
YWCLP : 255
IRIS GAIN : 200
EXIT MENU (YES→▲)
    
```

		Standard value
GAMMA	ON / OFF of GAMMA	:ON
MATRIX	ON / OFF of MATRIX	:ON
DTL	ON / OFF of DETAIL	:ON
APT	ON / OFF of APERTURE	:ON
YWCLP	Y WHITE CLP level setting	:255
IRIS GAIN	IRIS GAIN setting	:200

• Page 14 TITLE Color setting

```

PAGE14(NEXT→▼ PREV→▲)
R TTL : 75
G TTL : 75
B TTL : 75
R TTLB : 0
G TTLB : 0
B TTLB : 0
ABC123
EXIT MENU (YES→▲)
    
```

		Standard value
R TTL	R level of TITLE (0/25/50/75)	:75
G TTL	G level of TITLE (0/25/50/75)	:75
B TTL	B level of TITLE (0/25/50/75)	:75
R TTLB	TITLE edge emphasis of R level (0/25/50/75)	: 0
G TTLB	TITLE edge emphasis of G level (0/25/50/75)	: 0
B TTLB	TITLE edge emphasis of b level (0/25/50/75)	: 0
ABC123	Indication for actual TITLE color ensuring	

• Page 15 Various items setting 3

```

PAGE15(NEXT→▼ PREV→▲)
LL ADJ : 100
PKAVECOM : 128
IRIS MARK : 128
MGAM ADJ : 132
RGAM ADJ : ± 0
BGAM ADJ : ± 0
MBLK ADJ : 2068
EXIT MENU (YES→▲)
    
```

		Standard value
LL ADJ	Level setting for LL IND	:120 (NTSC) :154 (PAL)
PKAVECOM	Peak-AVE ratio setting of AUTO Iris	:100
IRIS MARK	Object value setting of AUTO Iris	:144
MGAMADJ	Standard value setting of Master GAMMA	:132
RGAMADJ	GAMMA offset setting of Rch	:±0
BGAMADJ	GAMMA offset setting of Bch	:±0
MBLKADJ	Standard value setting of Master BLACK	:2068 (NTSC) :2070 (PAL)

• Page 16 KNEE setting 3 (not in used)

```

PAGE16(NEXT→▼ PREV→▲)
R.KNEE S : ± 0
B.KNEE S : ± 0
R.KNEE P : ± 0
B.KNEE P : ± 0
EXIT MENU (YES→▲)
    
```

• Page 17 Various setting 4

```

PAGE17(NEXT→▼ PREV→▲)

ATW ADJ : AUTO(YES→▲)
  R : 126
  B : 134
MIC ADJ : 89
FILTER  : 2

EXIT MENU (YES→▲)
  
```

ATW ADJ Take in standard value of ATW
 R Standard value setting of ATW
 B Standard value setting of ATW
 MIC ADJ Setting of a musical note mark indication
 FILTER Destination setting of filter (standard:2)

Note : In ATW ADJ, it is taken in the calculation standard value of color temperature when the AUTO WHITE is carried out, therefore, normally, no adjustment is required.

When the indication value of color temperature is different from the actual value, confirm the output level of CCD unit. (How to confirmation : Refer to the SECTION 3 ALIGNMENT “3-3-11. CCD Output Level Adjustment”) If the output level of CCD unit is different from the specification, perform the CCD output level adjustment, and then, take in the standard value to the following procedures;

1. Shoot the pattern of 3200 K color temperature.
2. Set W. BAL switch to "A" position, and perform the AUTO WHITE balance.
3. Move the cursor to “ATW ADJ” by STATUS/MENU switch, and press UP ▲ switch.

• Page 18 Selfdiagnosis 1

```

PAGE18(NEXT→▼ PREV→▲)

DIAG ERROR RESET
      (YES→▲)

MEMORY BACKUP
      (YES→▲)

EXIT MENU (YES→▲)
  
```

DIAG ERROR RESET

The results of error check and the history of defective item are erased.

MEMORY BACKUP

The data of EEPROM on the TG, IF and ES boards are made backup copy to the EEPROM on the MB board.

If the communication between the EEPROM on the TG, IF, ES boards and microcomputer are abnormal when the power switch turns on, the data of backup copy on the EEPROM of the MB board is used because the data held on the EEPROM of TG, IF and ES boards can not be used.

Therefore, make backup copy, when changing the contents of the menu page 5 through page 8, page 11 and page 12, or when changing the one of TG, IF, ES and MB boards.

Note : The DIAG ERROR RESET and MEMORY BACKUP are carried out when the RESET on the service menu of page 1 is executed.

• Page 19 Selfdiagnosis 2

```
PAGE19(NEXT→▼ PREV→▲)
ERROR DISP 1/3
DISP SELECT : 1
PP-PMPD : 000H
PR-PMPD1 : 000H
PR-PMPD2 : 000H
PR-G2 : 000H
PR-R2 : 000H
EXIT MENU (YES→▲)
```

DISP SELECT

The contents of the defective items are changed.

- 1: The result of latest error is displayed.
- 2: This selfdiagnosis is automatically carried out, and the defective item diagnosed in the past are displayed.

PP-PMPD

The details of check result for the synchronization signal input and the internal RAM in PP LSI are displayed.

800H: The internal RAM of PP LSI is abnormal.

002H: The input HD signal (IC405, pin102) to the PP LSI is abnormal.

001H: The input VD signal (IC405, pin 101) to the PP LSI is abnormal.

Note : When the plural abnormality is occurred, the hexadecimal numbers of three digits are displayed in the total value of each error codes.

When both HD and VD signals inputted to the PP LSI are abnormal, the PP-PMPD is displayed in the 003H.

PR-PMPD1

The details of check result for the synchronization signal input in PP LSI are displayed.

002H: The input HD signal (IC411, pin74) to the PR LSI is abnormal.

001H: The input VD signal (IC411, pin73) to the PR LSI is abnormal.

PR-PMPD2

The details of check result for the internal RAM in PR LSI are displayed.

800H: The internal RAM of PR LSI.

PR-G2

This display item is not used.

PR-R2

This display item is not used.

• Page 20 Selfdiagnosis 3

```
PAGE20(NEXT→▼ PREV→▲)
ERROR DISP 2/3
DISP SELECT : 1
PR-G1 : 000H
PR-R1 : 000H
PR-G0 : 000H
PR-R0 : 000H
PR-B1 : 000H
EXIT MENU (YES→▲)
```

PR-G1

This display item is not used.

PR-R1

This display item is not used.

PR-G0

This display item is not used.

PR-R0

This display item is not used.

PR-B1

This display item is not used.

• Page 21 Selfdiagnosis 4

PAGE21(NEXT→▼ PREV→▲)

```
ERROR DISP 3/3
DISP SELECT : 1
RC- PMPD: 000H
RC- CY : 000H
RC- CCR : 000H
RC- CCB : 000H
DSP COM.: 000H
MEMORY : 000H
EXIT MENU (YES→▲)
```

RC-PMPD

The details of check result for synchronization signal input and the internal RAM in RC LSI are displayed.

800H: The internal RAM of RC LSI is abnormal.

004H: The input HD signal (IC520, pin64) to the RC LSI is abnormal.

002H: The input VD signal (IC520, pin65) to the RC LSI is abnormal.

001H: The input CF signal (IC520, pin63) to the RC LSI is abnormal.

RC-CY

The details of check result for the connection regarding the Y signal between PR LSI and RC LSI are displayed.

400H: The connection between PR IC411 pin94 and IF IC520 pin97 is abnormal.(The No.10 of Y signal)

200H: The connection between PR IC411 pin93 and IF IC520 pin98 is abnormal.(The No.9 of Y signal)

100H: The connection between PR IC411 pin92 and IF IC520 pin99 is abnormal.(The No.8 of Y signal)

080H: The connection between PR IC411 pin91 and IF IC520 pin100 is abnormal.(The No.7 of Y signal)

040H: The connection between PR IC411 pin90 and IF IC520 pin101 is abnormal.(The No.6 of Y signal)

020H: The connection between PR IC411 pin89 and IF IC520 pin103 is abnormal.(The No.5 of Y signal)

010H: The connection between PR IC411 pin88 and IF IC520 pin104 is abnormal.(The No.4 of Y signal)

008H: The connection between PR IC411 pin86 and IF IC520 pin105 is abnormal.(The No.3 of Y signal)

004H: The connection between PR IC411 pin85 and IF IC520 pin106 is abnormal.(The No.2 of Y signal)

002H: The connection between PR IC411 pin84 and IF IC520 pin107 is abnormal.(The No.1 of Y signal)

001H: The connection between PR IC411 pin83 and IF IC520 pin108 is abnormal.(The No.0 of Y signal)

RC-CCR

This display item is not used.

RC-CCB

This display item is not used.

Note : If the input of synchronization signal to the PR LSI or RC LSI is abnormal, the connection check between PR LSI and RC LSI is detected the abnormality.

DSP COM

The details of check result for the communication between each LSI and microcomputer.

004H: The communication between RC LSI and microcomputer is abnormal.

002H: The communication between PR LSI and microcomputer is abnormal.

001H: The communication between PP LSI and microcomputer is abnormal.

Note : The RC LSI is carried out into communication with the microcomputer by six pins of pin26(CS), pin25(SCK), pin24(SDA0), pin23(SDA1), pin22(SDA2) and pin21(SDA3). The PR LSI is carried out into communication with the microcomputer by six pins of pin58(CS), pin57(SCK), pin56(SDA0), pin55(SDA1), pin54(SDA2) and pin53(SDA3). The PP LSI is carried out into communication with the microcomputer by six pins of pin41(CS), pin40(SCK), pin39(SDA0), pin38(SDA1), pin37(SDA2) and pin36(SDA3). If the communication between LSI and the microcomputer is abnormal, the abnormality of other item may be detected at the same time.

MEMORY

The details of check result for the communication between each EEPROM and microcomputer.

080H: The communication between EEPROM of ES and microcomputer is abnormal.

040H: The communication between EEPROM of IF and microcomputer is abnormal.

020H: The communication between EEPROM of TG and microcomputer is abnormal.

010H: The communication between EEPROM of MB and microcomputer is abnormal.

Note : The corresponding display for the data of each EEPROM on the service menu becomes a blank column, when using the standard value of microcomputer, because of the EEPROM on the MB board is abnormal, or when using the backup copy, because of the EEPROM on the TG, IF and ES boards is abnormal.

• **Page 22 Present unit condition indication**

```
PAGE22(NEXT→▼ PREV→▲)
POWER      : 12.1V
TIS        : 224h
R GAIN     : 7e6h
B GAIN     : 800h
IRIS POS   : 000h
KWC        : 000h

EXIT MENU (YES→▲)
```

This is the communication of the production.
This is not related to service.

• **Page 23 TG ROM OPERATION**

```
PAGE23(NEXT→▼ PREV→▲)

TG ROM

EXIT MENU (YES→▲)
```

This display item is not used.

SECTION 3 ALIGNMENT

3-1. PREPARATION

3-1-1. Equipment Required

- Digital voltmeter
- Oscilloscope (100 MHz or more)
- Vectorscope
- Waveform monitor
- B/W monitor (Sony PVM-91/122 or equivalent)
- Color monitor (Sony PVM-1320 or equivalent)
- AC Adaptor (Sony CMA-8/8A/8CE/8ACE)
- Camera Adaptor (Sony CA-537/537P)
- Frequency counter
- SC-H Phase Equipment

3-1-2. Connection

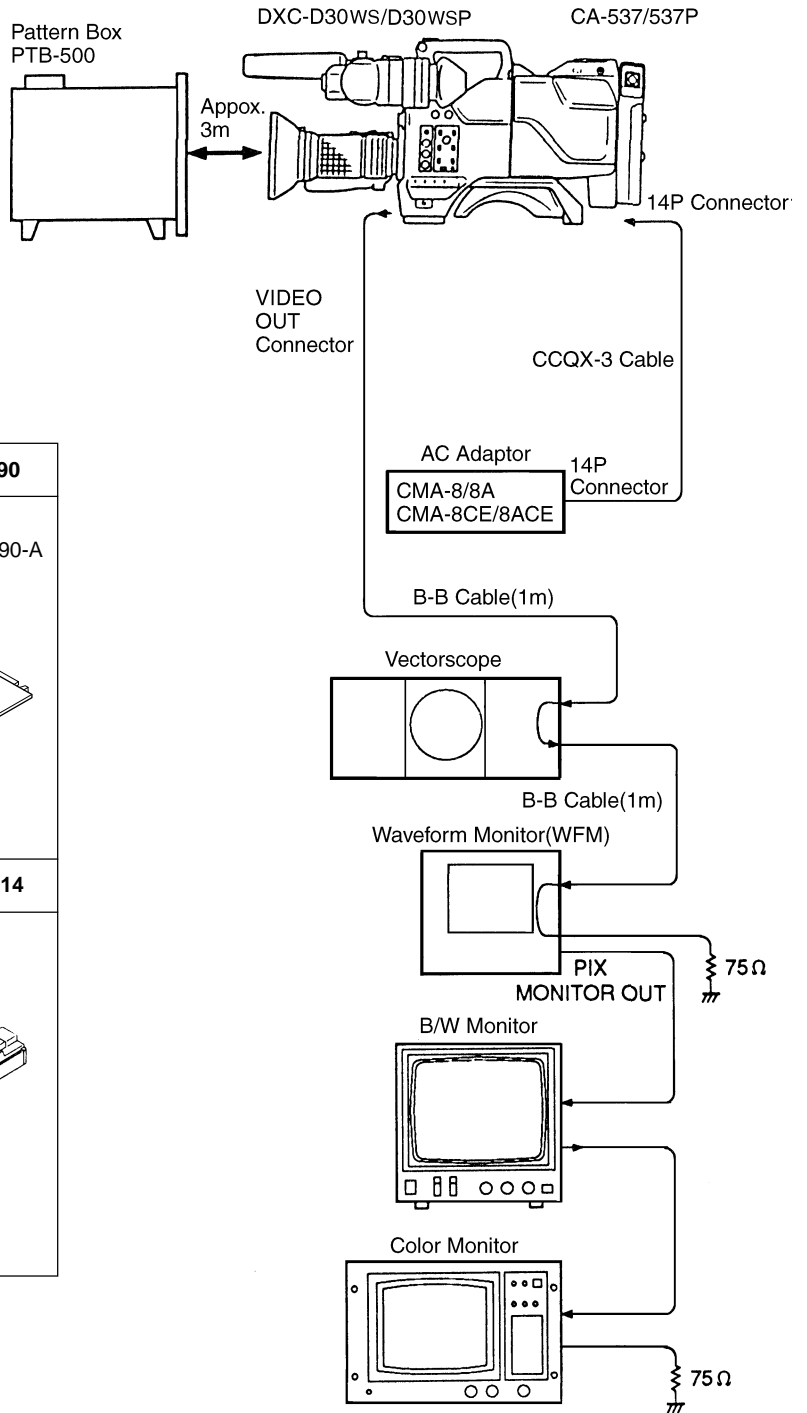

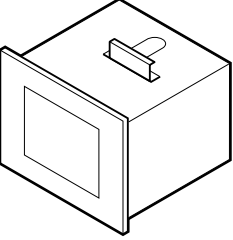
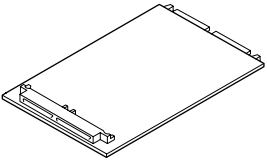
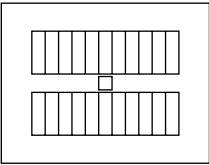
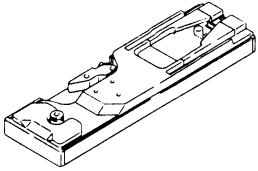
Pattern box PTB-500	extension board EX-490
Sony part number: J-6029-140-B • Light source for test chart 	Sony part number: J-6275-690-A 
Grayscale chart	Tripod Adaptor VCT-U14
Sony part number: J-6026-130-B 	

3-1-3. Switch Setting Before Adjustment

[DXC-D30WS, DXC-D30WSP]

Switch setting for camera side

GAIN switch : 0 dB
 OUTPUT/DL/DCC+ switch : CAM/DCC+
 WHITE BAL switch : PRESET
 FILTER control : 1
 SHUTTER switch : OFF
 ZEBRA switch : OFF
 MARKER switch : OFF
 HYPER GAIN switch : OFF
 SET UP switch : STD
 EZ MODE switch : OFF

IRIS (Lens) : Manual
 ZOOM (Lens) : Manual

[CA-537, CA-537P]

S1 switch (IF-313 board) : AUTO (Center position)

3-1-4. Notes on Adjustment

- Note:**
- (1) Before adjustment, be sure to allow for 10-minute warm-up time.
 - (2) When using the SERVICE menu, ADVANCE menu and BASIC menu, refer to “2-7. SERVICE MODE OPERATION”.
 - (3) Unless otherwise specified, the sentence “chart frame = underscanned monitor frame” is written about the shooting condition.
 In this case, make sure that the lens is best focused.
 Then adjust the zoom control of the lens so that the chart frame touches the underscanned monitor frame.

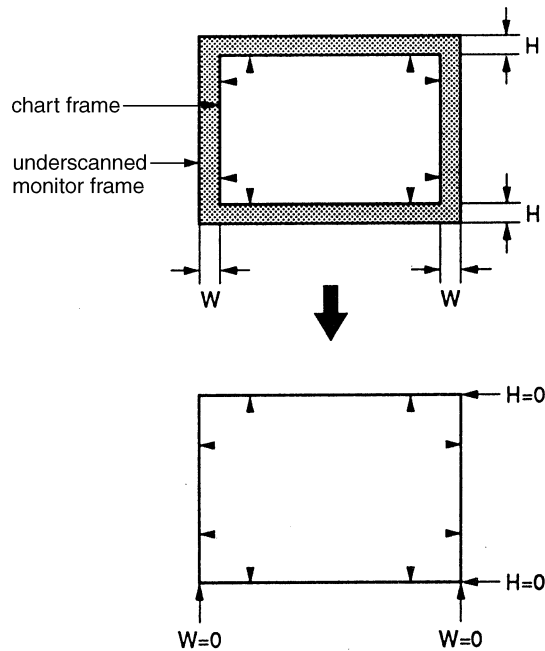

In case of the Grayscale chart:

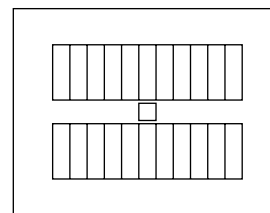

(underscanned monitor screen)

(4) When replacing the CCD unit, be sure to perform the following adjustment items.

3-3-12. Pedestal Adjustment

3-3-13. Shading Adjustment

3-3-14. Flare Adjustment

(5) If the amplitude level of the measured waveform is blurred on the waveform monitor screen, set the RESPONSE switch on the waveform monitor to "LUM" mode.

3-1-5. Adjustment Item

3-2. Before Adjustment

3-2-1. Color Bar Signal Confirmation

3-2-2. Sensitivity Measurement Confirmation

3-3. Camera Adjustment

3-3-1. Sub-Carrier Frequency Adjustment

3-3-2. INT SC-H Phase Adjustment

3-3-3. Y/R-Y/B-Y CLP Level Adjustment

3-3-4. Y/SYNC/R-Y/B-Y Level Adjustment

3-3-5. Carrier Balance Adjustment

3-3-6. Chroma (VBS) Level Adjustment

3-3-7. Y (VBS) Level Adjustment

3-3-8. Y (YC) Level Adjustment

3-3-9. Chroma (YC) Level Adjustment

3-3-10. VF SYNC/BLKG Level Adjustment

3-3-11. CCD Output Level Adjustment

3-3-12. Pedestal Adjustment

3-3-13. Shading Adjustment

3-3-14. Flare Adjustment

3-3-15. MIC LEVEL/MIC Level IND Adjustment

3-3-16. Character Position Adjustment

3-3-17. 4:3 Title Adjustment

3-2. BEFORE ADJUSTMENT

- Note:**
1. Before adjustment, connect the equipments referring to “3-1-2. Connection”.
 2. Before adjustment, Turn on POWER switch and allow for 10-minute warm-up time.

3-2-1. Color Bar Signal Confirmation

- Equipment:** Vectorscope, Waveform monitor
- Preparation:** OUTPUT/DL/DCC+ switch/camera side → BARS
- Test point:** VIDEO OUT connector/camera side
- Specification:**

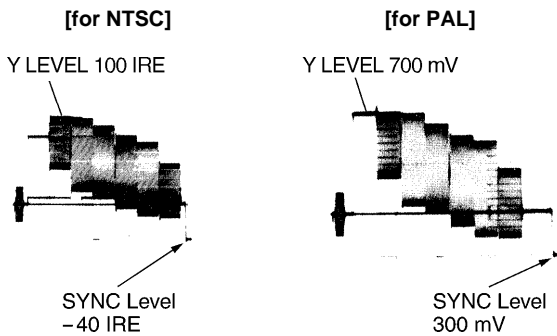

- Chroma Level
Confirm that the beam spots of each color (R, YL, G, CY, G, B and MG) are inside the “田” mark.

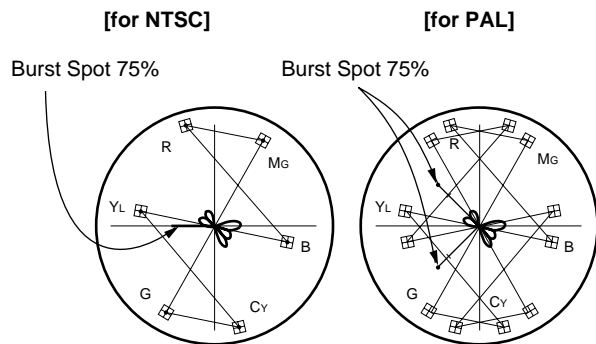

- Note:**
- Partial difference between scale and signal level is caused by photographic error.
 - If the specifications are not met, carry out from “3-3-2. INT SC Phase Adjustment” through “3-3-9. Chroma (YC) Level Adjustment”.

3-2-2. Sensitivity Measurement Confirmation

- Object:** Overall white
- Light:** 3200K, 2000 lux
(If the pattern box is used, set the AUTO mode)

Preparation:

- Adjust the zoom control at “TELE” so that the white pattern frame matches the underscanned picture frame on the screen.
- Lens iris → F11
- OUTPUT/DL/DCC+ switch/camera side → CAM
- WHITE BAL switch/camera side → PRESET

- Equipment:** Waveform monitor

- Specification:** 100 ± 10 IRE (for NTSC)
700 ± 70 mV (for PAL)

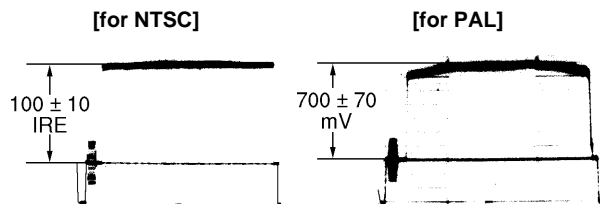

- Note:** If the specification is not met, perform “3-3-11. CCD OUT Level Adjustment”.

3-3. CAMERA ADJUSTMENT

Note: Before the adjustment, enter the “PAGE 1” of SERVICE menu, and perform the “RESET”.

3-3-1. Sub-Carrier Frequency Adjustment

Equipment: Frequency counter
To be extended: ES-22 board
Test point: TP501 (GND: E1(extension board)) /ES-22 board
Adjusting point: SERVICE menu “PAGE 8”
 → SC FREQ :
 Adjust the sub-Carrier Frequency by UP ▲ witch or DOWN ▼ switch.
Specification: 3,579,545 ±10 Hz (for NTSC)
 4,433,618 ±10 Hz (for PAL)

3-3-2. INT SC-H Phase Adjustment

Note: Stated below is a procedure with the SC-H phase measuring equipment (Tektronix Waveform monitor 1765).
 If any other equipment is used, perform adjustment at the following adjustment point by reading the instruction manual attached.

Equipment: Waveform monitor (SC-H Phase mode)

Preparation:

- Put the Tektronix Waveform monitor 1765 to SC-H mode.

Test point: VIDEO OUT connector/camera side

Adjustment Procedure

- SERVICE menu “PAGE 8”
 → SC-H
- Adjust the phase relationship between SC (Burst) and H beam spot correctly by UP ▲ switch or DOWN ▼ switch.

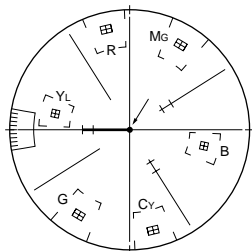

[for NTSC]

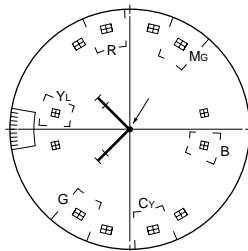

[for PAL]

Note: After this adjustment, set the mode of Tektronix Waveform monitor 1765 to “WFM” mode.

3-3-3. Y/R-Y/B-Y CLP Level Adjustment

Equipment: Oscilloscope

To be extended: IF-700 board

Preparation: OUTPUT/DL/DCC+ switch/camera side
 → BARS

Trigger: HD (TP83/extension board)

Adjustment Procedure:

- Select “PAGE 10” of SERVICE menu, make sure that R-Y and B-Y mode must be “ON”.
- SERVICE menu “PAGE 6”
 → Y CLP :
 R-Y CLP :
 B-Y CLP :
- Adjust the following items by UP ▲ switch or DOWN ▼ switch.

Note: In case of Y CLP for NTSC model, perform the adjustment as follows.

- Select “PAGE 9” of SERVICE menu, and set the “SETUP” to “OFF”.
- Select “PAGE 6” of SERVICE menu, and move the cursor to Y CLP.
- Adjustment: $A = 0 \pm 5$ mV
- Select “PAGE 9” of SERVICE menu, and set the “SETUP” to “ON”.
- And return to “PAGE 6”.

Extension board (GND : TP63/IF-700 board)

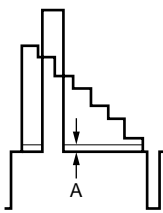
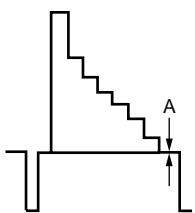
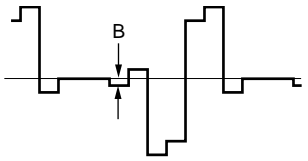
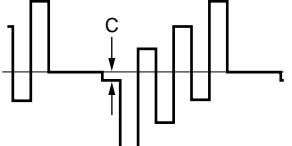
Item	Test Point	Specification
Y CLP	TP61	$A = 0 \pm 5$ mV
	(NTSC)	(PAL)
		
R-Y CLP	TP60	$B = 0 \pm 5$ mV
		
B-Y CLP	TP62	$C = 0 \pm 5$ mV
		

3-3-4. Y/SYNC/R-Y/B-Y Level Adjustment

Equipment: Oscilloscope

To be extended: IF-700 board

Preparation: OUTPUT/DL/DCC+ switch/camera side
→ BARS

Trigger: HD (TP83/extension board)

Adjustment Procedure:

1. Select "PAGE 9" of ADVANCE menu, make sure that "16:9/4:3" must be "16:9".
2. Select "PAGE 10" of SERVICE menu, make sure that R-Y and B-Y mode must be "ON".
3. SERVICE menu "PAGE 5"
→ W Y LVL :
W R-Y LVL :
W B-Y LVL :
SYNC LVL :
4. Adjust the following items by UP ▲ witch or DOWN ▼ switch.
5. Select "PAGE 9" of ADVANCE menu, and set the "16:9/4:3" to "4:3".
6. SERVICE menu "PAGE 5"
→ Y LVL :
R-Y LVL :
B-Y LVL :
S-UP LVL :
7. Adjust the following items by UP ▲ witch or DOWN ▼ switch.

Note: In case of Y LVL for NTSC model, perform the adjustment as follows.

- ① Move the cursor to Y LVL.
- ② Adjust the "A" of Y LVL level.
- ③ Move the cursor to S-UP LVL, and adjust the "F" of setup level.
- ④ Repeat item ① through ③ several times.

Extension board (GND : TP63/IF-532 board)

Item	Test Point	Specification
W Y LVL	TP61	NTSC : A = 714 ±10 mV F = 54 ±5 mV PAL : A = 700 ±10 mV
Y LVL	TP61	NTSC : A = 714 ±10 mV F = 54 ±5 mV PAL : A = 700 ±10 mV
SYNC LVL	TP61	NTSC : B = 286 ±5 mV PAL : B = 300 ±5 mV

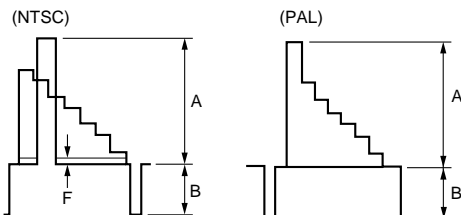

W R-Y LVL	TP60	NTSC : 700 ±20 mV PAL : 525 ±20 mV
R-Y LVL	TP60	NTSC : 700 ±20 mV PAL : 525 ±20 mV

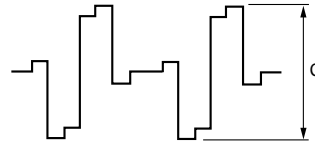

W B-Y LVL	TP62	NTSC : 700 ±20 mV PAL : 525 ±20 mV
B-Y LVL	TP62	NTSC : 700 ±20 mV PAL : 525 ±20 mV

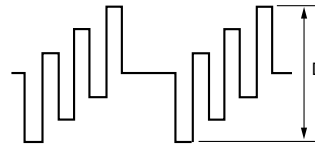

3-3-5. Carrier Balance Adjustment

Equipment: Verctorscope (MAX GAIN)

Preparation: OUTPUT/DL/DCC+ switch/camera side
→ BARS

Test point: VIDEO OUT connector/camera side

Adjusting point:

1. SERVICE menu "PAGE 7"
→ R-Y C/B :
B-Y C/B :
2. Move the cursor to R-Y C/B or B-Y C/B with STATUS/MENU switch, and adjust the UP ▲ switch or DOWN ▼ switch so that the beam spot is in the center of the vectorscope.

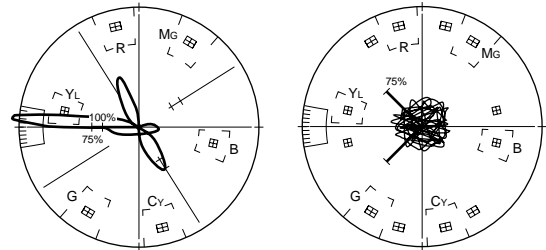

3-3-6. Chroma (VBS) Level Adjustment

Equipment: Verctorscope

To be extended: ES-22 board

Preparation:

- GAIN switch/Verctorscope → 75 % CAL
- Adjust the PHASE control on the vectorscope so that the burst spot is overlapped to the 75 % axis.
- OUTPUT/DL/DCC+ switch/camera side → BARS

Test point: VIDEO OUT connector/camera side

Adjustment Procedure:

1. [for NTSC]

- SERVICE menu “PAGE 7”
→ B-Y BST :

Note: In case of NTSC, make sure that “R-Y BST” must be “0”.

- Adjust the UP ▲ switch or DOWN ▼ switch so that burst spot is located at 75 % scale mark on the vectorscope screen.

[for PAL]

- SERVICE menu “PAGE 7”
→ R-Y BST :
B-Y BST :

- Adjust “R-Y BST” and “B-Y BST” alternately by UP ▲ switch or DOWN ▼ switch so that burst spot is located at 75 % scale mark on the vectorscope screen.

2. Adjust the following controls alternately so that each beam spot stays inside the reference frame “田”.

- RV503 (B-Y LEV)/ES-22 board
- FL502 (PHASE)/ES-22 board
- RV504 (CHROMA VBS LEV)/ ES-22 board

3. Then, perform above procedure item 1 again.

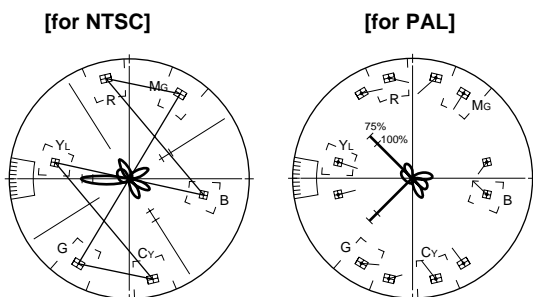

3-3-7. Y (VBS) Level Adjustment

Equipment: Waveform monitor

To be extended: ES-22 board

Preparation: OUTPUT/DL/DCC+ switch/camera side
→ BARS

Test point: VIDEO OUT connector/camera side

Adjustment Procedure

1. [for NTSC]

- SERVICE menu “PAGE 9”
→ SET UP : ON
MAT DEST : SMPTE

- SERVICE menu “PAGE 5”
→ S-UP LVL :
Adjust the UP ▲ switch or DOWN ▼ switch.

Specification : A = 7.5 ±0.5 IRE (See below waveform) ---- NTSC only

[for PAL]

- SERVICE menu “PAGE 9”
→ COMP LVL : 525 (not 700)

2. **Adjusting point:** RV501 (Y LEVEL)/ES-22 board

Specification: [for NTSC] B = 100 ±2 IRE
[for PAL] B = 700 ±10 mV

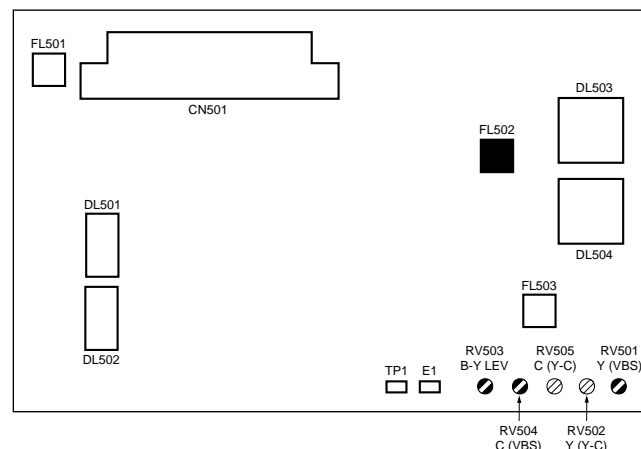
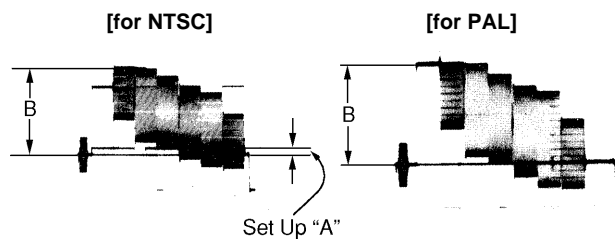

ES-22 BOARD -A SIDE-

3-3-8. Y (YC) Level Adjustment

Note: Be sure that “3-3-7. Y (VBS) Adjustment” is completed.

Equipment: Oscilloscope
To be extended: ES-22 board
Preparation: OUTPUT/DL/DCC+ switch/camera side
 → BARS

Test point: TP66 (GND: TP67)/extension board
Trigger: HD (TP84/extension board)

Adjusting point: ⓪RV502 (Y LEVEL)/ES-22 board
Specification: [for NTSC] $A = 1.00 \pm 0.02$ V
 [for PAL] $A = 1.00 \pm 0.02$ V

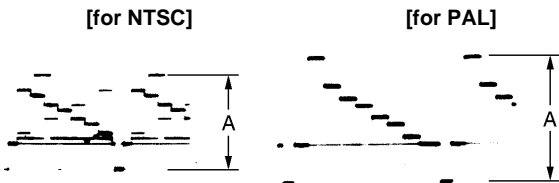

3-3-9. Chroma (YC) Level Adjustment

Equipment: Oscilloscope
To be extended: ES-22 board
Preparation: OUTPUT/DL/DCC+ switch/camera side
 → BARS

Test point: TP64 (GND: TP65)/extension board
Trigger: HD (TP84/extension board)

Adjusting point: ⓪RV505 (CHROMA (YC) LEV)/ES-22 board

Specification: [for NTSC] $A = 286 \pm 10$ mV
 [for PAL] $A = 300 \pm 10$ mV

[for NTSC]

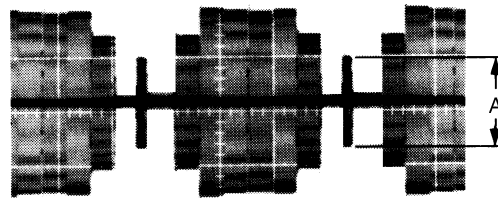

[for PAL]

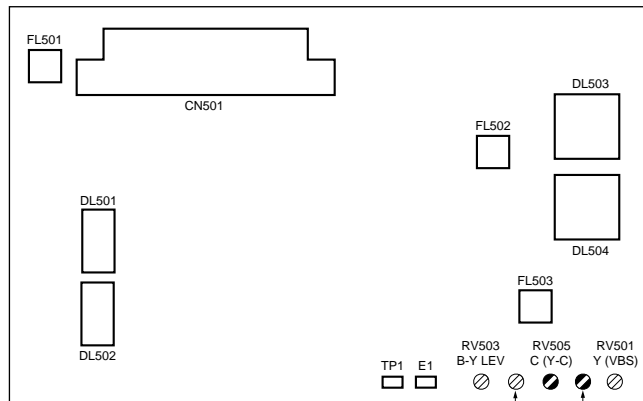
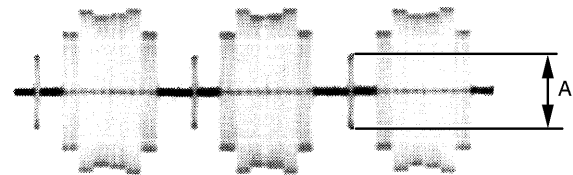

ES-22 BOARD -A SIDE-

3-3-10. VF SYNC/BLKG Level Adjustment

Equipment: Oscilloscope
To be extended: ES-22 board
Preparation: OUTPUT/DL/DCC+ switch/camera side
 → BARS
Trigger: HD (TP84/extension board)

Adjustment Procedure

- SERVICE menu “PAGE 7”
 VF SYNC
 → VF BLKG

Note: For the adjustment procedure, at the first “VF BLKG” adjustment is done, and next, “VF SYNC” adjustment is done.

- Adjust the following items by UP ▲ switch or DOWN ▼ switch.

Extension board (GND : TP81/ES-22 board)

Item	Test Point	Specification
VF BLKG	TP82	NTSC : A = 50 ±10 mV PAL : A = 50 ±10 mV
VF SYNC	TP82	NTSC : B = 286 ±10 mV PAL : B = 300 ±10 mV

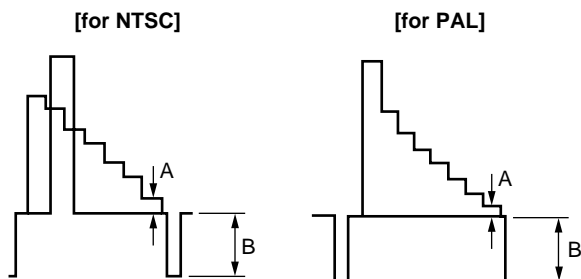

3-3-11. CCD Output Level Adjustment

Note :

- Use a reflection type with chart for this adjustment, therefore, control the light so that the white area of chart is exactly 3200K of color temperature.
- If use the pattern box, make sure that the color temperature must be 3200K.
- Usually, this adjustment is not required. Only when the output level of CCD unit is large different from the specification.
- When the new CCD unit of spare parts is replaced, this adjustment is not required because of the correct adjustment at the factory.

Object: Grayscale chart

Equipment: Oscilloscope

To be extended: VA-185 board

Preparation:

- OUTPUT/DL/DCC+ switch/camera side
 → CAM/DCC+
- WHITE BAL switch/camera side
 → PRESET
- Chart frame = Underscanned monitor frame
- Adjust the lens iris so that the video level at TP27/extension board (VA-185 board) is 165 ±5 mV.

Trigger: HD (TP72/extension board)

Adjustment Procedure

- Test point: TP15/extension board (VA-185 board)
 ●RV1/PA-219 (B) board
Specification : A = 165 ±5 mV
- Test point: TP21/extension board (VA-185 board)
 ●RV1/PA-221 (R) board
Specification : A = 165 ±5 mV

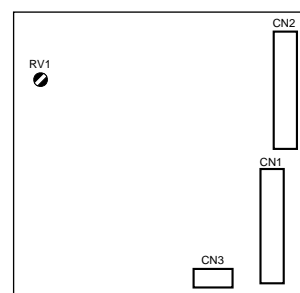

PA-219 (B) BOARD - A SIDE -
 PA-221 (R) BOARD - A SIDE -

3-3-12. Pedestal Adjustment

Equipment: Waveform monitor
Test point: VIDEO OUT/Camera side

Adjustment Procedure

1. SERVICE menu "PAGE 15"
→ MELK ADJ:
2. Close the lens iris.
3. Push down the "W/B" switch on the camera to "BLK" side.
4. Adjust the pedestal level by UP ▲ witch or DOWN ▼ switch.

Specification : $A = 10 \pm 1$ IRE (for NTSC)
 20 ± 7 mV (for PAL)



3-3-13. Shading Adjustment

Note : Perform this adjustment when the lens or CCD unit is replaced.

Object: White portion of pattern box
Equipment: Waveform monitor, Oscilloscope
To be extended: VA-185 board
Trigger: VD (TP73/extension board)

Adjustment Procedure

1. SERVICE menu "PAGE 2"
→ R SHAD:
G SHAD:
B SHAD:
2. Shoot the center portion of pattern box by zooming the lens to fully TELE position.
3. Adjust the lens iris so that the level "A" is 70 ± 2 IRE (for PAL: 490 ± 14 mV) on the VIDEO OUT connector of camera.

Waveform monitor

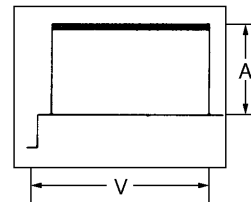

4. In the following mode, adjust the UP ▲ switch or DOWN ▼ switch so that the waveform of the oscilloscope becomes flat.

GND: TP38/extension board

Mode	Test point (VA-185 board)	Spec.
R SHAD	CL101	
G SHAD	CL201	
B SHAD	CL301	

3-3-14. Flare Adjustment

Object: Grayscale chart
Equipment: Waveform monitor
Preparation: OUTPUT/DL/DCC+ switch/camera side
 →CAM/DCC+

Adjustment Procedure

- SERVICE menu "PAGE 3"
 → R FLARE: x
 G FLARE: 0
 B FLARE: x

Note: Make sure that "G FLARE" must be "0".

- Chart frame = Underscanned monitor frame
- Test point:** VIDEO OUT connector/camera side

Adjusting point: Lens iris

Specification: A = 100 ± 2 IRE (for NTSC)
 700 ± 10 mV (for PAL)

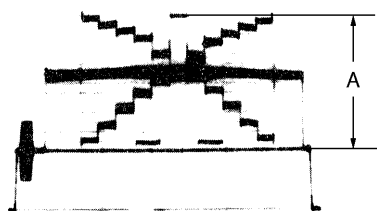

- Open the lens iris by two steps.
- Adjust "R FLARE" and "B FLARE" alternately by UP ▲ witch or DOWN ▼ witch so that the carrier leakage level is minimum.

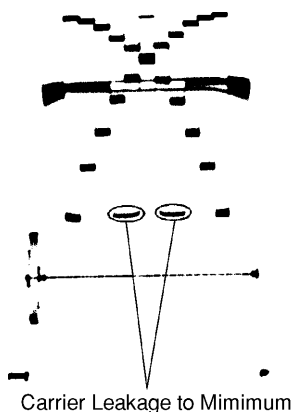

3-3-15. MIC LEVEL/MIC Level IND Adjustment

Equipment: Oscilloscope
Preparation: OUTPUT/DL/DCC+ switch/camera side
 → BARS

Adjustment Procedure

- Test point:** CL201/MB-785 board
 (GND: Capacitor, C202 ⊕ side/MB-785 board)

Adjusting point: ⓪RV201/MB-785 board

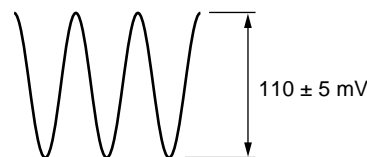

- SERVICE menu "PAGE 17"
 → MIC ADJ :
- Adjust the DOWN ▼ switch, and stop where the ♪ mark just appears on the monitor screen.
- Adjust the UP ▲ switch, and step where the ♪ mark just disappears on the monitor screen.
- And, set the ♪ mark to the value that subtract 10 time from the value by DOWN ▼ witch where the ♪ mark just disappears.

Monitor screen or Viewfinder screen.

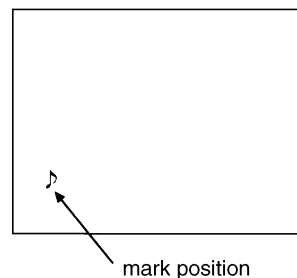

3-3-16. Character Position Adjustment

Equipment: Color monitor (or, B/W monitor)
Preparation: OUTPUT/DL/DCC+ switch/camera side
 → BARS
Test point: MONITOR OUT connector/camera side

Adjustment Procedure

1. Set the "MARKER" to "ON" on the BASIC menu.
2. Set the "MARKER" to "CENT/90 %" on the "PAGE 4" of ADVANCE menu.
3. Select "PAGE 9" on the ADVANCE menu, set "16:9/4:3" to "16:9" position.

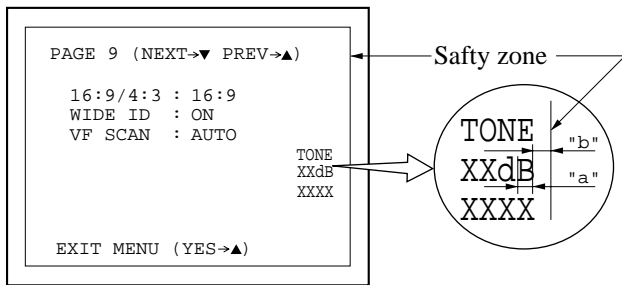

4. **Adjusting point:** ●CV3/MB-785 board
Specification: "a" ≒ "b"
 (The space between "a" and "b" are nearly equal)

3-3-17. 4:3 Title Adjustment

Equipment: Color monitor (or, B/W monitor)
Preparation: OUTPUT/DL/DCC+ switch/camera side
 → BARS
Test point: MONITOR OUT connector/camera side

Adjustment Procedure

1. Set the "MARKER" to "ON" on the BASIC menu.
2. Set the "MARKER" to "CENT/90 %" on the "PAGE 4" of ADVANCE menu.
3. Select "PAGE 9" on the ADVANCE menu, set "16:9/4:3" to "4:3" position.
4. Select "PAGE 8" on the ADVANCE menu.

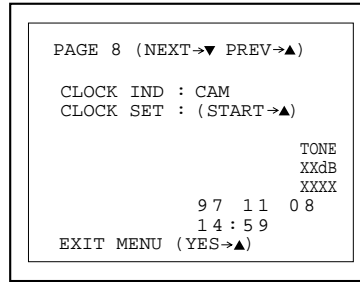

5. Set "CLOCK IND" to "CAM" position, (See above monitor screen) and set the cursor to "CLOCK SET" position. Push the UP ▲ switch, then, "(START → ▲)" is changed to "(END → ▲)" and the TITLE is displayed.

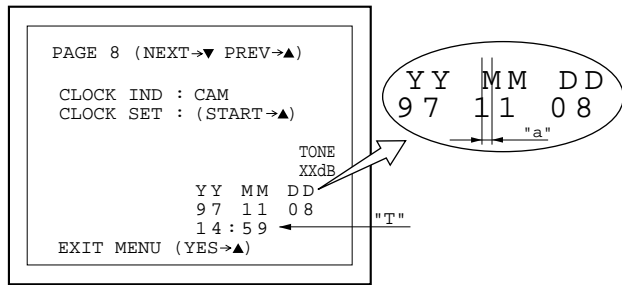

* In case of "DD MM YY", the adjustment is the same manner.

Note : In case of "MM DD YY", set the DATE position as follows.

MM DD YY
 11 08 97 "a"

6. **Adjusting point:** ●CV1/MB-785 board
Specification: "a" ≒ 0

Note : After adjustment, set the clock "T" for the present time.

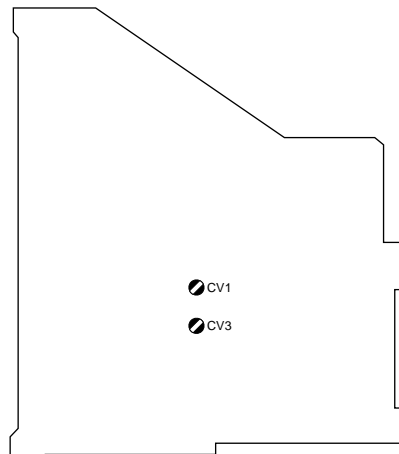

MB-785 BOARD -B SIDE-

このマニュアルに記載されている事柄の著作権は当社にあり、説明内容は機器購入者の使用を目的としています。従って、当社の許可なしに無断で複写したり、説明内容(操作、保守等)と異なる目的で本マニュアルを使用することを禁止します。

The material contained in this manual consists of information that is the property of Sony Corporation and is intended solely for use by the purchasers of the equipment described in this manual.

Sony Corporation expressly prohibits the duplication of any portion of this manual or the use thereof for any purpose other than the operation or maintenance of the equipment described in this manual without the express written permission of Sony Corporation.

Le matériel contenu dans ce manuel consiste en informations qui sont la propriété de Sony Corporation et sont destinées exclusivement à l'usage des acquéreurs de l'équipement décrit dans ce manuel.

Sony Corporation interdit formellement la copie de quel-que partie que ce soit de ce manuel ou son emploi pour tout autre but que des opérations ou entretiens de l'équipement à moins d'une permission écrite de Sony Corporation.

Das in dieser Anleitung enthaltene Material besteht aus Informationen, die Eigentum der Sony Corporation sind, und ausschließlich zum Gebrauch durch den Käufer der in dieser Anleitung beschriebenen Ausrüstung bestimmt sind. Die Sony Corporation untersagt ausdrücklich die Vervielfältigung jeglicher Teile dieser Anleitung oder den Gebrauch derselben für irgendeinen anderen Zweck als die Bedienung oder Wartung der in dieser Anleitung beschriebenen Ausrüstung ohne ausdrückliche schriftliche Erlaubnis der Sony Corporation.

DXC-D30WS (UC)
DXC-D30WSP (CE)
9-977-326-11

Sony Corporation
Image & Sound Communication Company

Printed in Japan
1997. 12 08
©1997
Published by
Engineering Services Dept.