



# VAIO User Guide

## How to Use

---

Parts Description

---

Setup

---

Network / Internet

---

Connections

---

Settings

---

View

---

Playback

---

Backup / Recovery

---

Security

---

Other Operations

---

Notifications

---

MONITOR Function

---

## SVL2411 Series

Use this manual if you encounter any problems, or have any questions about your VAIO computer.

[Read This First](#)



[▶ Troubleshooting](#)

**How to Use**

**Parts Description**

Setup

Network / Internet

Connections

Settings

View

Playback

Backup / Recovery

Security

Other Operations

Notifications

MONITOR Function

**Parts Description**

[Keyboard](#)

[Mouse](#)

[Remote commander](#)

[VAIO computer](#)



[▶ Troubleshooting](#)

**How to Use**

---

Parts Description

Setup

Network / Internet

---

Connections

---

Settings

---

View

---

Playback

---

Backup / Recovery

---

Security

---

Other Operations

---

Notifications

---

MONITOR Function

---

**Setup**

Display

Memory module

Power

VAIO computer

Keyboard

Mouse

Supplied items

---



[▶ Troubleshooting](#)

**How to Use**

---

Parts Description

---

Setup

**Network / Internet**

Connections

---

Settings

---

View

---

Playback

---

Backup / Recovery

---

Security

---

Other Operations

---

Notifications

---

MONITOR Function

---

**Network / Internet**

[Home network](#)

[LAN](#)

[Wireless LAN](#)

[Internet](#)

[Peripheral device](#)

---



[▶ Troubleshooting](#)

**How to Use**

---

Parts Description

---

Setup

---

Network / Internet

---

**Connections**

---

Settings

---

View

---

Playback

---

Backup / Recovery

---

Security

---

Other Operations

---

Notifications

---

MONITOR Function

---

**Connections**

[Antenna](#)

[BLUETOOTH](#)

[Display](#)

[Headphones](#)

[Internet](#)

[LAN](#)

[Mouse](#)

[Peripheral device](#)

[Speakers](#)

[USB](#)

[i.LINK](#)

[Audio](#)

[CD/DVD/BD](#)

[HDMI](#)

[Home network](#)

[Keyboard](#)

[Microphone](#)

[Optical digital output](#)

[Power](#)

[TV](#)

[Wireless LAN](#)



[▶ Troubleshooting](#)

**How to Use**

---

Parts Description

---

Setup

---

Network / Internet

---

Connections

---

**Settings**

---

View

---

Playback

---

Backup / Recovery

---

Security

---

Other Operations

---

Notifications

---

MONITOR Function

---

**Settings**

[Antenna](#)

[BIOS](#)

[CD/DVD/BD](#)

[Display](#)

[Home network](#)

[Keyboard](#)

[Microphone](#)

[Password](#)

[Power](#)

[Security](#)

[Software](#)

[TV](#)

[USB](#)

[VIDEO input](#)

[Audio](#)

[Button](#)

[Camera](#)

[HDMI](#)

[Internet](#)

[Memory module](#)

[Optical digital output](#)

[Peripheral device](#)

[Remote commander](#)

[Service and support](#)

[Speakers](#)

[Touch panel](#)

[VAIO computer](#)



[▶ Troubleshooting](#)

**How to Use**

---

Parts Description

---

Setup

---

Network / Internet

---

Connections

---

Settings

**View**

Playback

---

Backup / Recovery

---

Security

---

Other Operations

---

Notifications

---

MONITOR Function

---

**View**

[Antenna](#)

[Peripheral device](#)

[TV](#)

[Video](#)

---

[Music](#)

[Photo](#)

[VIDEO input](#)

---



[▶ Troubleshooting](#)

**How to Use**

---

Parts Description

---

Setup

---

Network / Internet

---

Connections

---

Settings

---

View

**Playback**

Backup / Recovery

---

Security

---

Other Operations

---

Notifications

---

MONITOR Function

---

**Playback**

[CD/DVD/BD](#)

[Peripheral device](#)

[Video](#)

---

[Music](#)

[Photo](#)





[▶ Troubleshooting](#)

**How to Use**

---

Parts Description

---

Setup

---

Network / Internet

---

Connections

---

Settings

---

View

---

Playback

---

**Backup / Recovery**

---

Security

---

Other Operations

---

Notifications

---

MONITOR Function

---

**Backup / Recovery**

[BIOS](#)

[Built-in storage device](#)

[CD/DVD/BD](#)

[Recovery](#)

[VAIO computer](#)

[Backup](#)

[Button](#)

[Partition](#)

[Service and support](#)

---



[▶ Troubleshooting](#)

**How to Use**

---

Parts Description

---

Setup

---

Network / Internet

---

Connections

---

Settings

---

View

---

Playback

---

Backup / Recovery

---

Security

---

Other Operations

---

Notifications

---

MONITOR Function

---

**Security**

[BIOS](#)

[Password](#)

[VAIO computer](#)

---

[Internet](#)

[Service and support](#)



[▶ Troubleshooting](#)

**How to Use**

---

Parts Description

---

Setup

---

Network / Internet

---

Connections

---

Settings

---

View

---

Playback

---

Backup / Recovery

---

Security

---

**Other Operations**

---

Notifications

---

MONITOR Function

---

**Other Operations**

[Audio](#)

[CD/DVD/BD](#)

[Display](#)

[Home network](#)

[Memory card](#)

[Mouse](#)

[Peripheral device](#)

[Remote commander](#)

[Touch panel](#)

[VAIO computer](#)

[Built-in storage device](#)

[Camera](#)

[HDMI](#)

[Keyboard](#)

[Memory module](#)

[Partition](#)

[Power](#)

[TV](#)

[USB](#)

[VIDEO input](#)

---



[▶ Troubleshooting](#)

**How to Use**

---

Parts Description

---

Setup

---

Network / Internet

---

Connections

---

Settings

---

View

---

Playback

---

Backup / Recovery

---

Security

---

Other Operations

Notifications

MONITOR Function

---

**Notifications**

[CD/DVD/BD](#)

[Important notice](#)

[Read this first](#)

[Service and support](#)

[VAIO computer](#)

[Care and maintenance](#)

[Product registration](#)

[Security](#)

[Supplied items](#)

---



[▶ Troubleshooting](#)

**How to Use**

---

Parts Description

---

Setup

---

Network / Internet

---

Connections

---

Settings

---

View

---

Playback

---

Backup / Recovery

---

Security

---

Other Operations

---

Notifications

---

**MONITOR Function**

**MONITOR Function**

[Antenna](#)

[Display](#)

[Home network](#)

[Music](#)

[Photo](#)

[Software](#)

[TV](#)

[VAIO computer](#)

[Video](#)

[Audio](#)

[HDMI](#)

[Internet](#)

[Peripheral device](#)

[Power](#)

[Speakers](#)

[USB](#)

[VIDEO input](#)



[▶ How to Use](#)

## Troubleshooting

---

Hardware

---

Software

---

Network / Internet

---

Backup / Recovery

---

Security

---

Peripheral Devices

---

Others

---

# VAIO User Guide

## SVL2411 Series

Use this manual if you encounter any problems, or have any questions about your VAIO computer.

[▶ Troubleshooting](#)

## How to Use

---

[Parts Description](#)

---

---

[Setup](#)

---

---

[Network / Internet](#)

---

---

[Connections](#)

---

---

[Settings](#)

---

---

[View](#)

---

---

[Playback](#)

---

---

[Backup / Recovery](#)

---

---

[Security](#)

---

---

[Other Operations](#)

---

---

[Notifications](#)

---

---

[MONITOR Function](#)

---

## Read This First

Congratulations on your purchase of this VAIO(R) computer and welcome to the on-screen User Guide.

### About your VAIO computer's configuration

To find out about the configuration of your VAIO computer, visit the Sony online support website. [\[Details\]](#)

Some features, options, and supplied items may not be available on your VAIO computer.

### Features

Available features vary depending on the model or options you selected. Not all features described in this manual are available depending on your model.

### Illustrations

Illustrations, photos, or screenshots in this manual may look slightly different depending on the model or options you selected.

### Software

The preinstalled software may vary depending on the model or options you selected. The software described in this manual may not be preinstalled on your VAIO computer.

### Supplied manuals

The following manuals are supplied with your VAIO computer.

#### On-screen documentation

- User Guide - Introduction version [\[Details\]](#)  
A preinstalled manual with limited information of your VAIO computer, focused on support and Internet connection. The User Guide - Introduction version is replaced with a complete version of the User Guide (this manual), after update.
- User Guide (this manual)  
General information and operation instructions about your VAIO computer including support and troubleshooting information

#### Printed documentation

- Quick Start Guide  
An overview of how to set up and get started with your VAIO computer
- Recovery, Backup and Troubleshooting Guide  
Information on how to recover and back up your VAIO computer, as well as troubleshooting information
- Safety Regulations  
Read carefully before activating the wireless functions such as the wireless LAN and BLUETOOTH technology.

## Other references

- Help and Support  
General information and technical support for your VAIO computer.  
To access Help and Support, click  (Start), then Help and Support. Next, choose a category to find answers to your questions.
  - Get started with my VAIO  
Get help with Internet and wireless setup, security setup, personalizing your VAIO computer, creating Recovery Media, and more.
  - Use my VAIO  
Get assistance with your VAIO computer by accessing useful information such as interactive VAIO tutorials, how-to articles, the VAIO technology page, specifications, and system and software information. Available information may vary depending on your model. Documentation such as the General User Guide and Model Specific User Guide are available on your computer.
  - Troubleshoot my VAIO  
Maintain and troubleshoot your VAIO computer with VAIO Care, system restore, backup and recovery, and contact Sony support.
- Software help files  
Software help files may be included with the preinstalled software on your VAIO computer. You may be able to access the help files from the help menu.

## Notice

- Copyright 2012 Sony Corporation. All rights reserved.
- This manual and the software described herein, in whole or in part, may not be reproduced, translated, or reduced to any machine-readable form without prior written approval.
- Sony Corporation provides no warranty with regard to this manual, the software, or other information contained herein and hereby expressly disclaims any implied warranties or merchantability or fitness for any particular purpose with regard to this manual, the software, or such other information. In no event shall Sony Corporation be liable for any incidental, consequential, or special damages, whether based on tort, contract, or otherwise, arising out of or in connection with this manual, the software, or other information contained herein or the use thereof.
- In the manual, the (TM) or (R) marks are not specified.
- Sony Corporation reserves the right to make any modification to this manual or the information contained herein at any time without notice. The software described herein is governed by the terms of a separate user license agreement.
- Sony Corporation is not liable and will not compensate for any lost recordings made to your VAIO computer, external recording media, or recording devices or any relevant losses, including when recordings are not made due to reasons including the computer failure, or when the contents of a recording are lost or damaged as a result of the computer failure or repair undertaken to the computer. Sony Corporation will not restore, recover, or replicate the recorded contents made to the computer, external recording media, or recording devices under any circumstances.
- Features and specifications are subject to change without notice.

---

## Related Topic

[About Online Support Website](#)

---



[▶ Troubleshooting](#)**How to Use****Parts Description**[Setup](#)[Network / Internet](#)[Connections](#)[Settings](#)[View](#)[Playback](#)[Backup / Recovery](#)[Security](#)[Other Operations](#)[Notifications](#)[MONITOR Function](#)**Keyboard****Parts and Controls of the Keyboard**

Describes the features of the keyboard, such as keys, buttons and indicator lights.

You might be looking for the following topics:

[About the Usage Environment for the Keyboard](#)[Changing the Button Assignment \(VAIO Button\)](#)[Checking the Caps Lock / Num Lock / Scroll Lock States](#)[Checking the Remaining Battery Power of the Keyboard](#)[Combinations and Functions with the Fn Key](#)[Connecting the Wireless Keyboard](#)[Replacing the AA Battery of the Keyboard](#)

[▶ Troubleshooting](#)**How to Use****Parts Description**[Setup](#)[Network / Internet](#)[Connections](#)[Settings](#)[View](#)[Playback](#)[Backup / Recovery](#)[Security](#)[Other Operations](#)[Notifications](#)[MONITOR Function](#)

## Remote commander

[Parts and Controls of the Remote Commander<TV tuner board installed models>](#)

Describes the features of the remote commander, such as buttons.

You might be looking for the following topics:

[Replacing the AA Battery of the Remote Commander<TV tuner board installed models>](#)

[▶ Troubleshooting](#)**How to Use****Parts Description**[Setup](#)[Network / Internet](#)[Connections](#)[Settings](#)[View](#)[Playback](#)[Backup / Recovery](#)[Security](#)[Other Operations](#)[Notifications](#)[MONITOR Function](#)**Mouse****Parts and Controls of the Mouse**

Describes the features of the mouse, such as buttons.

You might be looking for the following topics:

[About the Usage Environment for the Mouse](#)[Connecting the Wireless Mouse](#)[Replacing the AA Battery of the Mouse](#)

[▶ Troubleshooting](#)**How to Use****Parts Description**[Setup](#)[Network / Internet](#)[Connections](#)[Settings](#)[View](#)[Playback](#)[Backup / Recovery](#)[Security](#)[Other Operations](#)[Notifications](#)[MONITOR Function](#)**VAIO computer**[Parts and Controls on the Back](#)

Describes the features on the back of the VAIO computer, such as connection ports.

[Parts and Controls on the Bottom](#)

Describes the features on the bottom of the VAIO computer.

[Parts and Controls on the Front](#)

Describes the features on the front of the VAIO computer, such as buttons and indicator lights.

[Parts and Controls on the Sides](#)

Describes the features on the sides of the VAIO computer, such as connection ports.

You might be looking for the following topics:

[About Factory Setting \(MONITOR Function\)](#)[About the ASSIST Button](#)[About the Clock / Timers Settings \(MONITOR Function\)](#)[About the Front Panel Illumination Settings \(MONITOR Function\)](#)[About the MONITOR Indicator](#)[Adding and Removing Memory Modules](#)[Booting Your VAIO Computer from External Devices](#)[Checking Supplied Items](#)[Customizing Your VAIO Computer](#)[Displaying the Menu Screen \(MONITOR Function\)](#)[Keeping Your VAIO Computer in Optimum Condition \(VAIO Care\)](#)[Notes on Adding and Removing Memory Modules](#)[Preparing for Wall Mounting](#)[Setting Up an Appropriate Work Environment](#)[Updating Your VAIO Computer](#)[Using VAIO Update](#)[Using the Settings Menu \(MONITOR Function\)](#)[Viewing the System Information](#)

[▶ Troubleshooting](#)**How to Use**[Parts Description](#)[Setup](#)[Network / Internet](#)[Connections](#)[Settings](#)[View](#)[Playback](#)[Backup / Recovery](#)[Security](#)[Other Operations](#)[Notifications](#)[MONITOR Function](#)

## Display

### [Adjusting the Angle of the Screen](#)

You can adjust the screen angle of your choice.

You might be looking for the following topics:

[About Pro Picture Setup / Video Input Settings \(MONITOR Function\)](#)

[About the Auto Shut-off Settings \(MONITOR Function\)<TV tuner board installed models>](#)

[About the Closed Captions \(CC\) Settings \(MONITOR Function\)<TV tuner board installed models>](#)

[About the Info Banner Settings \(MONITOR Function\)<TV tuner board installed models>](#)

[About the Language Settings \(MONITOR Function\)](#)

[About the MONITOR Indicator](#)

[About the Picture Adjustments / Picture Settings \(MONITOR Function\)](#)

[About the Scene Select Settings \(MONITOR Function\)](#)

[About the Screen Settings \(MONITOR Function\)](#)

[About the Touch Screen<Touch screen equipped models>](#)

[Changing the LCD Brightness](#)

[Changing the Resolution \(Size\) of the Screen Image](#)

[Changing the Resolution \(Size\) of the Screen Image on an HDMI-Connected Device](#)

[Connecting a TV with an HDMI Input Port](#)

[Displaying Two Pictures on the Screen Simultaneously \(PIP\) <TV tuner board installed models>](#)

[Displaying Two Pictures side-by-side on the Screen \(P&P\)<TV tuner board installed models>](#)

[Displaying the Menu Screen \(MONITOR Function\)](#)

[Enable/Disable the Touch Screen<Touch screen equipped models>](#)

[Enjoying Sounds Only \(Picture Off\)](#)

[Enlarging the Text Size \(DPI\)<Touch screen equipped models>](#)

[How to Use the Touch Screen<Touch screen equipped models>](#)

[Multiple Touch Screen Operation](#)

[Notes on Using the Touch Screen<Touch screen equipped models>](#)

[Notes on the LCD screen](#)

[Selecting Display Modes](#)

[Turning Off the LCD Screen](#)

[Using the Multiple Monitors Function](#)

[Using the Settings Menu \(MONITOR Function\)](#)

[▶ Troubleshooting](#)

## How to Use

---

[Parts Description](#)[Setup](#)[Network / Internet](#)

---

[Connections](#)

---

[Settings](#)

---

[View](#)

---

[Playback](#)

---

[Backup / Recovery](#)

---

[Security](#)

---

[Other Operations](#)

---

[Notifications](#)

---

[MONITOR Function](#)

---

## Memory module

### [Adding and Removing Memory Modules](#)

If you want to increase your computer's speed or improve performance when running programs simultaneously, increase the amount of memory by installing optional memory modules.

### [Notes on Adding and Removing Memory Modules](#)

Before adding or removing memory modules, read the following precautions thoroughly.

You might be looking for the following topics:

[Viewing the System Information](#)

---

[▶ Troubleshooting](#)

## How to Use

---

[Parts Description](#)[Setup](#)[Network / Internet](#)

---

[Connections](#)

---

[Settings](#)

---

[View](#)

---

[Playback](#)

---

[Backup / Recovery](#)

---

[Security](#)

---

[Other Operations](#)

---

[Notifications](#)

---

[MONITOR Function](#)

---

## Power

### [Connecting a Power Source](#)

Connect your VAIO computer to an AC power source. Carefully read the precautions in [Notes on Using the Power Source](#) before connection. [Details]

### [Shutting Down Your VAIO Computer](#)

Shut down your VAIO computer properly to avoid losing unsaved data.

### [Turning on Your VAIO Computer](#)

Turn on your VAIO computer to start Windows. Carefully read the precautions in [Notes on Using the Power Source](#) before turning on. [Details]

You might be looking for the following topics:

[About the Clock / Timers Settings \(MONITOR Function\)](#)

[About the MONITOR Indicator](#)

[Notes on Sleep Mode](#)

[Notes on Using the Power Source](#)

[Restarting Your VAIO Computer](#)

[Selecting a Power Plan](#)

[Using Sleep Mode](#)

---

[▶ Troubleshooting](#)

## How to Use

---

[Parts Description](#)[Setup](#)[Network / Internet](#)

---

[Connections](#)

---

[Settings](#)

---

[View](#)

---

[Playback](#)

---

[Backup / Recovery](#)

---

[Security](#)

---

[Other Operations](#)

---

[Notifications](#)

---

[MONITOR Function](#)

---

## VAIO computer

### [Adding and Removing Memory Modules](#)

If you want to increase your computer's speed or improve performance when running programs simultaneously, increase the amount of memory by installing optional memory modules.

### [Checking Supplied Items](#)

Check all items packed with the product before use.

### [Notes on Adding and Removing Memory Modules](#)

Before adding or removing memory modules, read the following precautions thoroughly.

### [Preparing for Wall Mounting](#)

Your VAIO computer can be mounted on a wall using a wall mounting bracket (not supplied).

### [Setting Up an Appropriate Work Environment](#)

This topic describes where to or not to place your VAIO computer and ergonomic instructions.

You might be looking for the following topics:

[About Factory Setting \(MONITOR Function\)](#)[About the ASSIST Button](#)[About the Clock / Timers Settings \(MONITOR Function\)](#)[About the Front Panel Illumination Settings \(MONITOR Function\)](#)[About the MONITOR Indicator](#)[Booting Your VAIO Computer from External Devices](#)[Customizing Your VAIO Computer](#)[Displaying the Menu Screen \(MONITOR Function\)](#)[Keeping Your VAIO Computer in Optimum Condition \(VAIO Care\)](#)[Parts and Controls on the Back](#)[Parts and Controls on the Bottom](#)[Parts and Controls on the Front](#)[Parts and Controls on the Sides](#)[Updating Your VAIO Computer](#)[Using VAIO Update](#)[Using the Settings Menu \(MONITOR Function\)](#)[Viewing the System Information](#)



[▶ Troubleshooting](#)

## How to Use

---

[Parts Description](#)[Setup](#)[Network / Internet](#)

---

[Connections](#)

---

[Settings](#)

---

[View](#)

---

[Playback](#)

---

[Backup / Recovery](#)

---

[Security](#)

---

[Other Operations](#)

---

[Notifications](#)

---

[MONITOR Function](#)

---

## Keyboard

### [About the Usage Environment for the Keyboard](#)

This section explains how to use the wireless keyboard.

### [Replacing the AA Battery of the Keyboard](#)

Change the AA battery in the keyboard when the battery power becomes low.

You might be looking for the following topics:

[Changing the Button Assignment \(VAIO Button\)](#)

[Checking the Caps Lock / Num Lock / Scroll Lock States](#)

[Checking the Remaining Battery Power of the Keyboard](#)

[Combinations and Functions with the Fn Key](#)

[Connecting the Wireless Keyboard](#)

[Parts and Controls of the Keyboard](#)

---

[▶ Troubleshooting](#)

## How to Use

---

[Parts Description](#)[Setup](#)[Network / Internet](#)

---

[Connections](#)

---

[Settings](#)

---

[View](#)

---

[Playback](#)

---

[Backup / Recovery](#)

---

[Security](#)

---

[Other Operations](#)

---

[Notifications](#)

---

[MONITOR Function](#)

---

## Mouse

### [About the Usage Environment for the Mouse](#)

This section explains how to use the wireless mouse.

### [Replacing the AA Battery of the Mouse](#)

Change the AA battery in the mouse when the battery power becomes low.

You might be looking for the following topics:

[Connecting the Wireless Mouse](#)

[Parts and Controls of the Mouse](#)

---

[▶ Troubleshooting](#)

**How to Use**

---

Parts Description

Setup

Network / Internet

---

Connections

---

Settings

---

View

---

Playback

---

Backup / Recovery

---

Security

---

Other Operations

---

Notifications

---

MONITOR Function

---

**Supplied items**

[Checking Supplied Items](#)

Check all items packed with the product before use.

---

[▶ Troubleshooting](#)

## How to Use

---

[Parts Description](#)

---

[Setup](#)

---

[Network / Internet](#)

---

[Connections](#)

---

[Settings](#)

---

[View](#)

---

[Playback](#)

---

[Backup / Recovery](#)

---

[Security](#)

---

[Other Operations](#)

---

[Notifications](#)

---

[MONITOR Function](#)

---

## Home network

### [About Home Network Setup \(MONITOR Function\)](#)

This topic explains the home network setting.

### [About Media Remote](#)

Media Remote allows another device (for example, smartphone, PC) to control an input state other than PC such as HDMI input function via the network.

### [Connecting to a Home Network](#)

You can enjoy various content (for example, photo/music/video files) stored on DLNA-certified media servers. The home network feature allows you to enjoy network content in other rooms.

---

[▶ Troubleshooting](#)

## How to Use

---

[Parts Description](#)

---

[Setup](#)

---

[Network / Internet](#)

---

[Connections](#)

---

[Settings](#)

---

[View](#)

---

[Playback](#)

---

[Backup / Recovery](#)

---

[Security](#)

---

[Other Operations](#)

---

[Notifications](#)

---

[MONITOR Function](#)

---

## LAN

### [About the Internet Connection Services](#)

The following types of Internet connection services are available.

### [About the Network \(LAN\)](#)

The network (LAN) enables you to connect your VAIO computer to the Internet and transfer data between the computer and other devices.

### [About the Wireless LAN Standards](#)

The Wireless Local Area Network (WLAN) allows your VAIO computer to connect to a network through a wireless connection.

### [Connecting to the Internet with a Wired Connection](#)

Before using the Internet, you need to sign up with an Internet Service Provider (ISP) and set up devices required for connecting your VAIO computer to the Internet.

---

[▶ Troubleshooting](#)

## How to Use

---

[Parts Description](#)

---

[Setup](#)

---

[Network / Internet](#)

---

[Connections](#)

---

[Settings](#)

---

[View](#)

---

[Playback](#)

---

[Backup / Recovery](#)

---

[Security](#)

---

[Other Operations](#)

---

[Notifications](#)

---

[MONITOR Function](#)

---

## Wireless LAN

### [About a Security Key for a Wireless LAN](#)

A security key is a security protocol for a wireless LAN that encrypts data transmitted on the wireless LAN.

### [About the Internet Connection Services](#)

The following types of Internet connection services are available.

### [About the Wireless LAN Standards](#)

The Wireless Local Area Network (WLAN) allows your VAIO computer to connect to a network through a wireless connection.

### [Before Using the Wireless LAN](#)

You first need to establish wireless LAN communications between your VAIO computer and an access point (not supplied) before connecting the computer to the Internet using the wireless LAN. Refer to Windows Help and Support and the manual that came with your access point for more information.

### [Notes on Using the Wireless LAN Function](#)

Before using the wireless LAN function, read the following precautions for correct use.

### [Starting Wireless LAN Communications](#)

You can establish wireless LAN communications between your VAIO computer and an access point (not supplied) using VAIO Smart Network. Before using the wireless LAN, make sure your access point is on and operating.

### [Stopping Wireless LAN Communications](#)

Stop wireless LAN communications using VAIO Smart Network.

---

[▶ Troubleshooting](#)**How to Use**[Parts Description](#)[Setup](#)[Network / Internet](#)[Connections](#)[Settings](#)[View](#)[Playback](#)[Backup / Recovery](#)[Security](#)[Other Operations](#)[Notifications](#)[MONITOR Function](#)**Internet**[About Network Setup \(MONITOR Function\)](#)

This topic explains the network setting of the MONITOR ONLY LAN port.

[About a Security Key for a Wireless LAN](#)

A security key is a security protocol for a wireless LAN that encrypts data transmitted on the wireless LAN.

[About the Internet Connection Services](#)

The following types of Internet connection services are available.

[About the Network \(LAN\)](#)

The network (LAN) enables you to connect your VAIO computer to the Internet and transfer data between the computer and other devices.

[About the Wireless LAN Standards](#)

The Wireless Local Area Network (WLAN) allows your VAIO computer to connect to a network through a wireless connection.

[Before Using the Wireless LAN](#)

You first need to establish wireless LAN communications between your VAIO computer and an access point (not supplied) before connecting the computer to the Internet using the wireless LAN. Refer to Windows Help and Support and the manual that came with your access point for more information.

[Connecting to the Internet with a Wired Connection](#)

Before using the Internet, you need to sign up with an Internet Service Provider (ISP) and set up devices required for connecting your VAIO computer to the Internet.

[Launching the Web Browser \(WEB Button\)](#)

By pressing the WEB button, you can launch the default web browser.

[Notes on Using the Wireless LAN Function](#)

Before using the wireless LAN function, read the following precautions for correct use.

[Starting Wireless LAN Communications](#)

You can establish wireless LAN communications between your VAIO computer and an access point (not supplied) using VAIO Smart Network. Before using the wireless LAN, make sure your access point is on and operating.

[Stopping Wireless LAN Communications](#)

Stop wireless LAN communications using VAIO Smart Network.

[Using the Antivirus Software for Your VAIO Computer](#)

Protect your VAIO computer against computer viruses by using the antivirus software.

[▶ Troubleshooting](#)

## How to Use

---

[Parts Description](#)

---

[Setup](#)

---

[Network / Internet](#)

---

[Connections](#)

---

[Settings](#)

---

[View](#)

---

[Playback](#)

---

[Backup / Recovery](#)

---

[Security](#)

---

[Other Operations](#)

---

[Notifications](#)

---

[MONITOR Function](#)

---

## Peripheral device

### [About Media Remote](#)

Media Remote allows another device (for example, smartphone, PC) to control an input state other than PC such as HDMI input function via the network.

### [Connecting to a Home Network](#)

You can enjoy various content (for example, photo/music/video files) stored on DLNA-certified media servers. The home network feature allows you to enjoy network content in other rooms.

You might be looking for the following topics:

[About HDMI Settings / HDMI Setup \(MONITOR Function\)](#)

[About the USB Auto Start Settings \(MONITOR Function\)](#)

[About "BRAVIA" Sync](#)

[Changing the Sound Output Device](#)

[Connecting a High-Quality Digital Sound Output Device between Your VAIO Computer and a TV](#)

[Connecting a TV with an HDMI Input Port](#)

[Connecting a VCR or DVD Player](#)

[Connecting an Audio System](#)

[Connecting an External Microphone](#)

[Displaying the Menu Screen \(MONITOR Function\)](#)

[Enjoying Sounds from Connected Audio System](#)

[Notes on the LCD screen](#)

[Operating "Control for HDMI"-Compatible Equipment](#)

[Selecting Display Modes](#)

[Using the Multiple Monitors Function](#)

[Using the Settings Menu \(MONITOR Function\)](#)

[Viewing Pictures from Connected Equipment](#)



[▶ Troubleshooting](#)

## How to Use

---

[Parts Description](#)

---

[Setup](#)

---

[Network / Internet](#)

---

[Connections](#)

---

[Settings](#)

---

[View](#)

---

[Playback](#)

---

[Backup / Recovery](#)

---

[Security](#)

---

[Other Operations](#)

---

[Notifications](#)

---

[MONITOR Function](#)

---

## Antenna

### [About Antenna Connection<TV tuner board installed models>](#)

To watch TV with your VAIO computer, you must first connect the necessary cables, such as for the antenna, etc.

### [Connecting to Standard Cable Access \(CATV\)<TV tuner board installed models>](#)

You can connect your computer to an indoor/outdoor antenna system in CATV mode.

### [Connecting to a Standard Antenna<TV tuner board installed models>](#)

Depending on the type of antenna system in your home, your connection may require a VHF/UHF RF combiner/transformer to connect the computer and the indoor/outdoor antenna system.

You might be looking for the following topics:

[About the Cable/Antenna Settings \(MONITOR Function\)<TV tuner board installed models>](#)

---

[▶ Troubleshooting](#)

## How to Use

[Parts Description](#)[Setup](#)[Network / Internet](#)[Connections](#)[Settings](#)[View](#)[Playback](#)[Backup / Recovery](#)[Security](#)[Other Operations](#)[Notifications](#)[MONITOR Function](#)

## BLUETOOTH

### [About BLUETOOTH\(R\) Security<BLUETOOTH equipped models>](#)

The BLUETOOTH wireless technology has an authentication function, which allows you to control communication with other devices.

### [About the BLUETOOTH\(R\) Function<BLUETOOTH equipped models>](#)

You can establish wireless communications between your VAIO computer and other BLUETOOTH devices, such as another computer, a smartphone, a mobile phone, a headset, or a mouse.

### [Communicating with Another BLUETOOTH\(R\) Device such as a Mouse<BLUETOOTH equipped models>](#)

You can connect BLUETOOTH devices to your VAIO computer. For details on BLUETOOTH communication, see [About the BLUETOOTH Function <BLUETOOTH equipped models>](#).  
[Details]

### [Notes on Using the BLUETOOTH\(R\) Function<BLUETOOTH equipped models>](#)

Before using the BLUETOOTH function, read the following precautions for correct use.

### [Stopping BLUETOOTH\(R\) Communications<BLUETOOTH equipped models>](#)

Stop BLUETOOTH communications using VAIO Smart Network.

[▶ Troubleshooting](#)**How to Use**[Parts Description](#)[Setup](#)[Network / Internet](#)[Connections](#)[Settings](#)[View](#)[Playback](#)[Backup / Recovery](#)[Security](#)[Other Operations](#)[Notifications](#)[MONITOR Function](#)

## Display

### [Changing the Resolution \(Size\) of the Screen Image on an HDMI-Connected Device](#)

You can change the screen resolution or size of your VAIO computer's screen image displayed on an external display, such as a TV, connected to the computer with an HDMI cable (not supplied).

### [Connecting a TV with an HDMI Input Port](#)

You can connect a TV with an HDMI input port to your VAIO computer with an HDMI cable (not supplied).

### [Notes on the LCD screen](#)

Read the following precautions for correct use of the LCD screen.

### [Selecting Display Modes](#)

You can switch the display output between the computer screen and an external display connected to your VAIO computer.

### [Using the Multiple Monitors Function](#)

The Multiple Monitors function allows you to distribute portions of your desktop across separate displays.

You might be looking for the following topics:

[About Pro Picture Setup / Video Input Settings \(MONITOR Function\)](#)

[About the Auto Shut-off Settings \(MONITOR Function\)<TV tuner board installed models>](#)

[About the Closed Captions \(CC\) Settings \(MONITOR Function\)<TV tuner board installed models>](#)

[About the Info Banner Settings \(MONITOR Function\)<TV tuner board installed models>](#)

[About the Language Settings \(MONITOR Function\)](#)

[About the MONITOR Indicator](#)

[About the Picture Adjustments / Picture Settings \(MONITOR Function\)](#)

[About the Scene Select Settings \(MONITOR Function\)](#)

[About the Screen Settings \(MONITOR Function\)](#)

[About the Touch Screen<Touch screen equipped models>](#)

[Adjusting the Angle of the Screen](#)

[Changing the LCD Brightness](#)

[Changing the Resolution \(Size\) of the Screen Image](#)

[Displaying Two Pictures on the Screen Simultaneously \(PIP\) <TV tuner board installed models>](#)

[Displaying Two Pictures side-by-side on the Screen \(P&P\)<TV tuner board installed models>](#)

[Displaying the Menu Screen \(MONITOR Function\)](#)

[Enable/Disable the Touch Screen<Touch screen equipped models>](#)

[Enjoying Sounds Only \(Picture Off\)](#)

[Enlarging the Text Size \(DPI\)<Touch screen equipped models>](#)

[How to Use the Touch Screen<Touch screen equipped models>](#)

[Multiple Touch Screen Operation](#)

[Notes on Using the Touch Screen<Touch screen equipped models>](#)

[Turning Off the LCD Screen](#)



[▶ Troubleshooting](#)

## How to Use

---

[Parts Description](#)

---

[Setup](#)

---

[Network / Internet](#)

---

[Connections](#)

---

[Settings](#)

---

[View](#)

---

[Playback](#)

---

[Backup / Recovery](#)

---

[Security](#)

---

[Other Operations](#)

---

[Notifications](#)

---

[MONITOR Function](#)

---

## Headphones

### Connecting External Speakers or Headphones

You can connect external sound output devices (such as speakers or headphones) to your VAIO computer.

---

[▶ Troubleshooting](#)**How to Use**[Parts Description](#)[Setup](#)[Network / Internet](#)[Connections](#)[Settings](#)[View](#)[Playback](#)[Backup / Recovery](#)[Security](#)[Other Operations](#)[Notifications](#)[MONITOR Function](#)

## Internet

### [About a Security Key for a Wireless LAN](#)

A security key is a security protocol for a wireless LAN that encrypts data transmitted on the wireless LAN.

### [About the Internet Connection Services](#)

The following types of Internet connection services are available.

### [About the Network \(LAN\)](#)

The network (LAN) enables you to connect your VAIO computer to the Internet and transfer data between the computer and other devices.

### [About the Wireless LAN Standards](#)

The Wireless Local Area Network (WLAN) allows your VAIO computer to connect to a network through a wireless connection.

### [Before Using the Wireless LAN](#)

You first need to establish wireless LAN communications between your VAIO computer and an access point (not supplied) before connecting the computer to the Internet using the wireless LAN. Refer to Windows Help and Support and the manual that came with your access point for more information.

### [Connecting to the Internet with a Wired Connection](#)

Before using the Internet, you need to sign up with an Internet Service Provider (ISP) and set up devices required for connecting your VAIO computer to the Internet.

### [Launching the Web Browser \(WEB Button\)](#)

By pressing the WEB button, you can launch the default web browser.

### [Notes on Using the Wireless LAN Function](#)

Before using the wireless LAN function, read the following precautions for correct use.

### [Starting Wireless LAN Communications](#)

You can establish wireless LAN communications between your VAIO computer and an access point (not supplied) using VAIO Smart Network. Before using the wireless LAN, make sure your access point is on and operating.

### [Stopping Wireless LAN Communications](#)

Stop wireless LAN communications using VAIO Smart Network.

### [Using the Antivirus Software for Your VAIO Computer](#)

Protect your VAIO computer against computer viruses by using the antivirus software.

You might be looking for the following topics:

[About Network Setup \(MONITOR Function\)](#)

[▶ Troubleshooting](#)

## How to Use

---

[Parts Description](#)

---

[Setup](#)

---

[Network / Internet](#)

---

[Connections](#)

---

[Settings](#)

---

[View](#)

---

[Playback](#)

---

[Backup / Recovery](#)

---

[Security](#)

---

[Other Operations](#)

---

[Notifications](#)

---

[MONITOR Function](#)

---

## LAN

### [About the Internet Connection Services](#)

The following types of Internet connection services are available.

### [About the Network \(LAN\)](#)

The network (LAN) enables you to connect your VAIO computer to the Internet and transfer data between the computer and other devices.

### [About the Wireless LAN Standards](#)

The Wireless Local Area Network (WLAN) allows your VAIO computer to connect to a network through a wireless connection.

### [Connecting to the Internet with a Wired Connection](#)

Before using the Internet, you need to sign up with an Internet Service Provider (ISP) and set up devices required for connecting your VAIO computer to the Internet.

---

[▶ Troubleshooting](#)

## How to Use

---

[Parts Description](#)

---

[Setup](#)

---

[Network / Internet](#)

---

[Connections](#)

---

[Settings](#)

---

[View](#)

---

[Playback](#)

---

[Backup / Recovery](#)

---

[Security](#)

---

[Other Operations](#)

---

[Notifications](#)

---

[MONITOR Function](#)

---

## Mouse

### [About the Usage Environment for the Mouse](#)

This section explains how to use the wireless mouse.

### [Connecting the Wireless Mouse](#)

If you cannot use the wireless mouse supplied with your VAIO computer, it is likely that wireless connection setup is required between the wireless mouse and the computer.

You might be looking for the following topics:

[Parts and Controls of the Mouse](#)

[Replacing the AA Battery of the Mouse](#)

---



[▶ Troubleshooting](#)**How to Use**[Parts Description](#)[Setup](#)[Network / Internet](#)[Connections](#)[Settings](#)[View](#)[Playback](#)[Backup / Recovery](#)[Security](#)[Other Operations](#)[Notifications](#)[MONITOR Function](#)**Peripheral device**[About Media Remote](#)

Media Remote allows another device (for example, smartphone, PC) to control an input state other than PC such as HDMI input function via the network.

[Changing the Sound Output Device](#)

If there is no sound from the device connected to your VAIO computer, you need to change the device for sound output.

[Connecting a High-Quality Digital Sound Output Device between Your VAIO Computer and a TV](#)

You can connect a high-quality home theater receiver or other surround sound decoder devices between your VAIO computer and a TV using an HDMI connection.

[Connecting a TV with an HDMI Input Port](#)

You can connect a TV with an HDMI input port to your VAIO computer with an HDMI cable (not supplied).

[Connecting a VCR or DVD Player](#)

By connecting a VCR or DVD player to your VAIO computer, you can enjoy pictures on the computer screen.

[Connecting an Audio System](#)

Connect an audio system such as an AV amplifier or a home theater system to your VAIO computer.

[Connecting an External Microphone](#)

You can connect an external microphone to your VAIO computer and enjoy voice chat, etc.

[Connecting to a Home Network](#)

You can enjoy various content (for example, photo/music/video files) stored on DLNA-certified media servers. The home network feature allows you to enjoy network content in other rooms.

[Notes on the LCD screen](#)

Read the following precautions for correct use of the LCD screen.

[Selecting Display Modes](#)

You can switch the display output between the computer screen and an external display connected to your VAIO computer.

[Using the Multiple Monitors Function](#)

The Multiple Monitors function allows you to distribute portions of your desktop across separate displays.

You might be looking for the following topics:

[About HDMI Settings / HDMI Setup \(MONITOR Function\)](#)

[About the USB Auto Start Settings \(MONITOR Function\)](#)

[About "BRAVIA" Sync](#)

[Displaying the Menu Screen \(MONITOR Function\)](#)

[Enjoying Sounds from Connected Audio System](#)



[▶ Troubleshooting](#)

## How to Use

---

[Parts Description](#)

---

[Setup](#)

---

[Network / Internet](#)

---

[Connections](#)

---

[Settings](#)

---

[View](#)

---

[Playback](#)

---

[Backup / Recovery](#)

---

[Security](#)

---

[Other Operations](#)

---

[Notifications](#)

---

[MONITOR Function](#)

---

## Speakers

### [Connecting External Speakers or Headphones](#)

You can connect external sound output devices (such as speakers or headphones) to your VAIO computer.

You might be looking for the following topics:

[About the Speakers Settings \(MONITOR Function\)](#)

[Adjusting the Speakers Volume](#)

---

[▶ Troubleshooting](#)

## How to Use

---

[Parts Description](#)

---

[Setup](#)

---

[Network / Internet](#)

---

[Connections](#)

---

[Settings](#)

---

[View](#)

---

[Playback](#)

---

[Backup / Recovery](#)

---

[Security](#)

---

[Other Operations](#)

---

[Notifications](#)

---

[MONITOR Function](#)

---

## USB

### Charging a USB Device

You can charge a USB device even while your VAIO computer is off, in Hibernate mode, or Sleep mode by enabling the USB charging settings.

### Connecting a USB Device

You can connect a Universal Serial Bus (USB) device such as a mouse, floppy disk drive, speaker or printer to your VAIO computer. Installation of the device driver software supplied with the USB device may be required when connecting. Refer to the manual that came with the device for more information.

You might be looking for the following topics:

[About the USB Auto Start Settings \(MONITOR Function\)](#)

---

[▶ Troubleshooting](#)

## How to Use

---

[Parts Description](#)

---

[Setup](#)

---

[Network / Internet](#)

---

[Connections](#)

---

[Settings](#)

---

[View](#)

---

[Playback](#)

---

[Backup / Recovery](#)

---

[Security](#)

---

[Other Operations](#)

---

[Notifications](#)

---

[MONITOR Function](#)

---

## i.LINK

### About i.LINK

i.LINK is a Serial Digital Interface that transfers digital video/audio signals bi-directionally between i.LINK devices, and allows you to operate other i.LINK devices.

### Connecting a Digital Video Camcorder with an i.LINK Cable

You can connect an i.LINK device such as a digital video camcorder, to the i.LINK port on your VAIO computer.

---

[▶ Troubleshooting](#)**How to Use**[Parts Description](#)[Setup](#)[Network / Internet](#)[Connections](#)[Settings](#)[View](#)[Playback](#)[Backup / Recovery](#)[Security](#)[Other Operations](#)[Notifications](#)[MONITOR Function](#)**Audio**[Changing the Sound Output Device](#)

If there is no sound from the device connected to your VAIO computer, you need to change the device for sound output.

[Connecting External Speakers or Headphones](#)

You can connect external sound output devices (such as speakers or headphones) to your VAIO computer.

[Connecting a High-Quality Digital Sound Output Device between Your VAIO Computer and a TV](#)

You can connect a high-quality home theater receiver or other surround sound decoder devices between your VAIO computer and a TV using an HDMI connection.

[Connecting an External Microphone](#)

You can connect an external microphone to your VAIO computer and enjoy voice chat, etc.

You might be looking for the following topics:

[About the MTS Audio Settings \(MONITOR Function\)<TV tuner board installed models>](#)

[About the Scene Select Settings \(MONITOR Function\)](#)

[About the Sound Adjustments / Sound Settings \(MONITOR Function\)](#)

[About the Speakers Settings \(MONITOR Function\)](#)

[Adjusting the Microphone Volume](#)

[Adjusting the Speakers Volume](#)

[Adjusting the Volume in Windows](#)

[Displaying the Menu Screen \(MONITOR Function\)](#)

[Enjoying Sounds Only \(Picture Off\)](#)

[Turning Off the LCD Screen](#)

[Using the Settings Menu \(MONITOR Function\)](#)

[▶ Troubleshooting](#)

## How to Use

---

[Parts Description](#)

---

[Setup](#)

---

[Network / Internet](#)

---

[Connections](#)

---

[Settings](#)

---

[View](#)

---

[Playback](#)

---

[Backup / Recovery](#)

---

[Security](#)

---

[Other Operations](#)

---

[Notifications](#)

---

[MONITOR Function](#)

---

## CD/DVD/BD

### [Connecting an External DVD Drive](#)

Connect an external DVD drive or hard disk drive to a USB port on your VAIO computer.

You might be looking for the following topics:

[About Region Codes<Optical disc drive equipped models>](#)

[Booting Your VAIO Computer from External Devices](#)

[Handling Discs<Optical disc drive equipped models>](#)

[Inserting/Removing a Disc<Optical disc drive equipped models>](#)

[Notes on Using Discs<Optical disc drive equipped models>](#)

[Supported Discs<Optical disc drive equipped models>](#)

---

[▶ Troubleshooting](#)

## How to Use

---

[Parts Description](#)

---

[Setup](#)

---

[Network / Internet](#)

---

[Connections](#)

---

[Settings](#)

---

[View](#)

---

[Playback](#)

---

[Backup / Recovery](#)

---

[Security](#)

---

[Other Operations](#)

---

[Notifications](#)

---

[MONITOR Function](#)

---

## HDMI

### [Changing the Resolution \(Size\) of the Screen Image on an HDMI-Connected Device](#)

You can change the screen resolution or size of your VAIO computer's screen image displayed on an external display, such as a TV, connected to the computer with an HDMI cable (not supplied).

### [Connecting a TV with an HDMI Input Port](#)

You can connect a TV with an HDMI input port to your VAIO computer with an HDMI cable (not supplied).

### [Connecting a VCR or DVD Player](#)

By connecting a VCR or DVD player to your VAIO computer, you can enjoy pictures on the computer screen.

### [Connecting an Audio System](#)

Connect an audio system such as an AV amplifier or a home theater system to your VAIO computer.

You might be looking for the following topics:

[About HDMI Settings / HDMI Setup \(MONITOR Function\)](#)

[About "BRAVIA" Sync](#)

[Operating "Control for HDMI"-Compatible Equipment](#)

---



[▶ Troubleshooting](#)

## How to Use

---

[Parts Description](#)

---

[Setup](#)

---

[Network / Internet](#)

---

[Connections](#)

---

[Settings](#)

---

[View](#)

---

[Playback](#)

---

[Backup / Recovery](#)

---

[Security](#)

---

[Other Operations](#)

---

[Notifications](#)

---

[MONITOR Function](#)

---

## Home network

### [About Media Remote](#)

Media Remote allows another device (for example, smartphone, PC) to control an input state other than PC such as HDMI input function via the network.

### [Connecting to a Home Network](#)

You can enjoy various content (for example, photo/music/video files) stored on DLNA-certified media servers. The home network feature allows you to enjoy network content in other rooms.

You might be looking for the following topics:

[About Home Network Setup \(MONITOR Function\)](#)

---

[▶ Troubleshooting](#)

## How to Use

---

[Parts Description](#)

---

[Setup](#)

---

[Network / Internet](#)

---

[Connections](#)

---

[Settings](#)

---

[View](#)

---

[Playback](#)

---

[Backup / Recovery](#)

---

[Security](#)

---

[Other Operations](#)

---

[Notifications](#)

---

[MONITOR Function](#)

---

## Keyboard

### [About the Usage Environment for the Keyboard](#)

This section explains how to use the wireless keyboard.

### [Connecting the Wireless Keyboard](#)

If you cannot use the wireless keyboard supplied with the computer, it is likely that wireless connection setup is required between the wireless keyboard and your VAIO computer.

You might be looking for the following topics:

[Changing the Button Assignment \(VAIO Button\)](#)[Checking the Caps Lock / Num Lock / Scroll Lock States](#)[Checking the Remaining Battery Power of the Keyboard](#)[Combinations and Functions with the Fn Key](#)[Parts and Controls of the Keyboard](#)[Replacing the AA Battery of the Keyboard](#)

---

[▶ Troubleshooting](#)

## How to Use

---

[Parts Description](#)

---

[Setup](#)

---

[Network / Internet](#)

---

[Connections](#)

---

[Settings](#)

---

[View](#)

---

[Playback](#)

---

[Backup / Recovery](#)

---

[Security](#)

---

[Other Operations](#)

---

[Notifications](#)

---

[MONITOR Function](#)

---

## Microphone

### [Connecting an External Microphone](#)

You can connect an external microphone to your VAIO computer and enjoy voice chat, etc.

You might be looking for the following topics:

[Adjusting the Microphone Volume](#)

---

[▶ Troubleshooting](#)

## How to Use

---

[Parts Description](#)

---

[Setup](#)

---

[Network / Internet](#)

---

[Connections](#)

---

[Settings](#)

---

[View](#)

---

[Playback](#)

---

[Backup / Recovery](#)

---

[Security](#)

---

[Other Operations](#)

---

[Notifications](#)

---

[MONITOR Function](#)

---

## Optical digital output

### [Connecting a High-Quality Digital Sound Output Device between Your VAIO Computer and a TV](#)

You can connect a high-quality home theater receiver or other surround sound decoder devices between your VAIO computer and a TV using an HDMI connection.

---

[▶ Troubleshooting](#)

## How to Use

---

[Parts Description](#)

---

[Setup](#)

---

[Network / Internet](#)

---

[Connections](#)

---

[Settings](#)

---

[View](#)

---

[Playback](#)

---

[Backup / Recovery](#)

---

[Security](#)

---

[Other Operations](#)

---

[Notifications](#)

---

[MONITOR Function](#)

---

## Power

### [Connecting a Power Source](#)

Connect your VAIO computer to an AC power source. Carefully read the precautions in [Notes on Using the Power Source](#) before connection. [Details]

You might be looking for the following topics:

[About the Clock / Timers Settings \(MONITOR Function\)](#)

[About the MONITOR Indicator](#)

[Notes on Sleep Mode](#)

[Notes on Using the Power Source](#)

[Restarting Your VAIO Computer](#)

[Selecting a Power Plan](#)

[Shutting Down Your VAIO Computer](#)

[Turning on Your VAIO Computer](#)

[Using Sleep Mode](#)

---

[▶ Troubleshooting](#)**How to Use**[Parts Description](#)[Setup](#)[Network / Internet](#)[Connections](#)[Settings](#)[View](#)[Playback](#)[Backup / Recovery](#)[Security](#)[Other Operations](#)[Notifications](#)[MONITOR Function](#)**TV**[About Antenna Connection<TV tuner board installed models>](#)

To watch TV with your VAIO computer, you must first connect the necessary cables, such as for the antenna, etc.

[Connecting to Standard Cable Access \(CATV\)<TV tuner board installed models>](#)

You can connect your computer to an indoor/outdoor antenna system in CATV mode.

[Connecting to a Standard Antenna<TV tuner board installed models>](#)

Depending on the type of antenna system in your home, your connection may require a VHF/UHF RF combiner/transformer to connect the computer and the indoor/outdoor antenna system.

You might be looking for the following topics:

[About Add Digital Channels \(MONITOR Function\)<TV tuner board installed models>](#)[About Auto Program \(MONITOR Function\)<TV tuner board installed models>](#)[About Edit Channel Labels \(MONITOR Function\)<TV tuner board installed models>](#)[About Show/Hide Channels \(MONITOR Function\)<TV tuner board installed models>](#)[About TV Initial Setup \(MONITOR Function\)<TV tuner board installed models>](#)[About the Analog Fine Tune Settings \(MONITOR Function\)<TV tuner board installed models>](#)[About the Cable/Antenna Settings \(MONITOR Function\)<TV tuner board installed models>](#)[About the Closed Captions \(CC\) Settings \(MONITOR Function\)<TV tuner board installed models>](#)[About the Info Banner Settings \(MONITOR Function\)<TV tuner board installed models>](#)[About the MTS Audio Settings \(MONITOR Function\)<TV tuner board installed models>](#)[About the Parental Lock Settings \(MONITOR Function\)<TV tuner board installed models>](#)[About the Signal Diagnostics Settings \(MONITOR Function\)<TV tuner board installed models>](#)[Quitting TV<TV tuner board installed models>](#)[Running TV Initial Setup<TV tuner board installed models>](#)[Watching TV with Your VAIO Computer<TV tuner board installed models>](#)

[▶ Troubleshooting](#)**How to Use**[Parts Description](#)[Setup](#)[Network / Internet](#)[Connections](#)[Settings](#)[View](#)[Playback](#)[Backup / Recovery](#)[Security](#)[Other Operations](#)[Notifications](#)[MONITOR Function](#)

## Wireless LAN

### [About a Security Key for a Wireless LAN](#)

A security key is a security protocol for a wireless LAN that encrypts data transmitted on the wireless LAN.

### [About the Internet Connection Services](#)

The following types of Internet connection services are available.

### [About the Wireless LAN Standards](#)

The Wireless Local Area Network (WLAN) allows your VAIO computer to connect to a network through a wireless connection.

### [Before Using the Wireless LAN](#)

You first need to establish wireless LAN communications between your VAIO computer and an access point (not supplied) before connecting the computer to the Internet using the wireless LAN. Refer to Windows Help and Support and the manual that came with your access point for more information.

### [Notes on Using the Wireless LAN Function](#)

Before using the wireless LAN function, read the following precautions for correct use.

### [Starting Wireless LAN Communications](#)

You can establish wireless LAN communications between your VAIO computer and an access point (not supplied) using VAIO Smart Network. Before using the wireless LAN, make sure your access point is on and operating.

### [Stopping Wireless LAN Communications](#)

Stop wireless LAN communications using VAIO Smart Network.

[▶ Troubleshooting](#)

## How to Use

---

[Parts Description](#)

---

[Setup](#)

---

[Network / Internet](#)

---

[Connections](#)

---

[Settings](#)

---

[View](#)

---

[Playback](#)

---

[Backup / Recovery](#)

---

[Security](#)

---

[Other Operations](#)

---

[Notifications](#)

---

[MONITOR Function](#)

---

## Antenna

### [About Antenna Connection<TV tuner board installed models>](#)

To watch TV with your VAIO computer, you must first connect the necessary cables, such as for the antenna, etc.

### [About the Cable/Antenna Settings \(MONITOR Function\)<TV tuner board installed models>](#)

Sets the received signal to Cable or Antenna.

### [Connecting to Standard Cable Access \(CATV\)<TV tuner board installed models>](#)

You can connect your computer to an indoor/outdoor antenna system in CATV mode.

### [Connecting to a Standard Antenna<TV tuner board installed models>](#)

Depending on the type of antenna system in your home, your connection may require a VHF/UHF RF combiner/transformer to connect the computer and the indoor/outdoor antenna system.

---



[▶ Troubleshooting](#)

## How to Use

---

[Parts Description](#)

---

[Setup](#)

---

[Network / Internet](#)

---

[Connections](#)

---

[Settings](#)

---

[View](#)

---

[Playback](#)

---

[Backup / Recovery](#)

---

[Security](#)

---

[Other Operations](#)

---

[Notifications](#)

---

[MONITOR Function](#)

---

## BIOS

### [Booting Your VAIO Computer from External Devices](#)

You can boot your VAIO computer from external devices, such as an optical disc drive or a USB floppy disk drive, by using the BIOS function.

### [Removing the Power-on Password](#)

If power-on password input for booting up your VAIO computer is no longer necessary, follow these steps to remove the machine password and user password.

### [Setting/Changing the Power-on Password](#)

You can set a password (power-on password) for booting up your VAIO computer, using the BIOS function. Entry of the power-on password will be prompted after the VAIO logo appears to start the computer.

---

[▶ Troubleshooting](#)

## How to Use

---

[Parts Description](#)

---

[Setup](#)

---

[Network / Internet](#)

---

[Connections](#)

---

[Settings](#)

---

[View](#)

---

[Playback](#)

---

[Backup / Recovery](#)

---

[Security](#)

---

[Other Operations](#)

---

[Notifications](#)

---

[MONITOR Function](#)

---

## CD/DVD/BD

### [Booting Your VAIO Computer from External Devices](#)

You can boot your VAIO computer from external devices, such as an optical disc drive or a USB floppy disk drive, by using the BIOS function.

You might be looking for the following topics:

[About Region Codes<Optical disc drive equipped models>](#)

[Connecting an External DVD Drive](#)

[Handling Discs<Optical disc drive equipped models>](#)

[Inserting/Removing a Disc<Optical disc drive equipped models>](#)

[Notes on Using Discs<Optical disc drive equipped models>](#)

[Supported Discs<Optical disc drive equipped models>](#)

---

[▶ Troubleshooting](#)**How to Use**[Parts Description](#)[Setup](#)[Network / Internet](#)[Connections](#)[Settings](#)[View](#)[Playback](#)[Backup / Recovery](#)[Security](#)[Other Operations](#)[Notifications](#)[MONITOR Function](#)

## Display

[About Pro Picture Setup / Video Input Settings \(MONITOR Function\)](#)

This topic explains the advanced- picture settings.

[About the Auto Shut-off Settings \(MONITOR Function\)<TV tuner board installed models>](#)

Turns the TV off when no input signal is detected for 15 minutes.

[About the Closed Captions \(CC\) Settings \(MONITOR Function\)<TV tuner board installed models>](#)

This setting allows you to select from several closed caption modes.

[About the Info Banner Settings \(MONITOR Function\)<TV tuner board installed models>](#)

Sets the amount of information to display about the currently viewed TV channel and program.

[About the Language Settings \(MONITOR Function\)](#)

Sets the language displayed on the menu screens.

[About the Picture Adjustments / Picture Settings \(MONITOR Function\)](#)

This topic explains picture adjustments (for input sources other than PC).

[About the Scene Select Settings \(MONITOR Function\)](#)

This setting allows you to optimize picture and sound quality according to the input source.

[About the Screen Settings \(MONITOR Function\)](#)

This topic explains screen settings.

[Changing the LCD Brightness](#)

You can adjust the LCD brightness.

[Changing the Resolution \(Size\) of the Screen Image](#)

You can change the screen resolution to adjust the size of the characters and images on the computer screen.

[Changing the Resolution \(Size\) of the Screen Image on an HDMI-Connected Device](#)

You can change the screen resolution or size of your VAIO computer's screen image displayed on an external display, such as a TV, connected to the computer with an HDMI cable (not supplied).

[Connecting a TV with an HDMI Input Port](#)

You can connect a TV with an HDMI input port to your VAIO computer with an HDMI cable (not supplied).

[Displaying Two Pictures on the Screen Simultaneously \(PIP\) <TV tuner board installed models>](#)

This feature lets you watch two pictures on the screen simultaneously.

[Displaying Two Pictures side-by-side on the Screen \(P&P\)<TV tuner board installed models>](#)

This feature lets you watch two pictures on the screen side-by-side.

### [Displaying the Menu Screen \(MONITOR Function\)](#)

With the menu screen, you can customize the settings and switch the input source.

### [Enable/Disable the Touch Screen<Touch screen equipped models>](#)

By default, the touch screen of the VAIO computer is enabled. To disable/enable the touch screen, do the following:

### [Enjoying Sounds Only \(Picture Off\)](#)

This feature lets you enjoy sound only with the LCD screen turned off.

### [Enlarging the Text Size \(DPI\)<Touch screen equipped models>](#)

You can change the DPI to enlarge the font size, making it easier to touch specific text.

### [How to Use the Touch Screen<Touch screen equipped models>](#)

You can tap the touch screen or make a simple motion with your fingers to operate the VAIO computer.

### [Multiple Touch Screen Operation](#)

In the VAIO Touch Portal, you can choose a wide variety of software that can be enjoyed with touch screen operation.

### [Notes on Using the Touch Screen<Touch screen equipped models>](#)

Before using the touch screen, read the following precautions for correct use.

### [Notes on the LCD screen](#)

Read the following precautions for correct use of the LCD screen.

### [Selecting Display Modes](#)

You can switch the display output between the computer screen and an external display connected to your VAIO computer.

### [Using the Multiple Monitors Function](#)

The Multiple Monitors function allows you to distribute portions of your desktop across separate displays.

### [Using the Settings Menu \(MONITOR Function\)](#)

With the settings menu, you can customize the settings such as the display and sound settings.

You might be looking for the following topics:

[About the MONITOR Indicator](#)

[About the Touch Screen<Touch screen equipped models>](#)

[Adjusting the Angle of the Screen](#)

[Turning Off the LCD Screen](#)

[▶ Troubleshooting](#)

## How to Use

---

[Parts Description](#)

---

[Setup](#)

---

[Network / Internet](#)

---

[Connections](#)

---

[Settings](#)

---

[View](#)

---

[Playback](#)

---

[Backup / Recovery](#)

---

[Security](#)

---

[Other Operations](#)

---

[Notifications](#)

---

[MONITOR Function](#)

---

## Home network

### [About Home Network Setup \(MONITOR Function\)](#)

This topic explains the home network setting.

You might be looking for the following topics:

[About Media Remote](#)

[Connecting to a Home Network](#)

---

[▶ Troubleshooting](#)

## How to Use

---

[Parts Description](#)

---

[Setup](#)

---

[Network / Internet](#)

---

[Connections](#)

---

[Settings](#)

---

[View](#)

---

[Playback](#)

---

[Backup / Recovery](#)

---

[Security](#)

---

[Other Operations](#)

---

[Notifications](#)

---

[MONITOR Function](#)

---

## Keyboard

### [Changing the Button Assignment \(VAIO Button\)](#)

You can change the current task assigned to the VAIO button. [\[Details\]](#)

You might be looking for the following topics:

[About the Usage Environment for the Keyboard](#)

[Checking the Caps Lock / Num Lock / Scroll Lock States](#)

[Checking the Remaining Battery Power of the Keyboard](#)

[Combinations and Functions with the Fn Key](#)

[Connecting the Wireless Keyboard](#)

[Parts and Controls of the Keyboard](#)

[Replacing the AA Battery of the Keyboard](#)

---

[▶ Troubleshooting](#)

## How to Use

---

[Parts Description](#)

---

[Setup](#)

---

[Network / Internet](#)

---

[Connections](#)

---

[Settings](#)

---

[View](#)

---

[Playback](#)

---

[Backup / Recovery](#)

---

[Security](#)

---

[Other Operations](#)

---

[Notifications](#)

---

[MONITOR Function](#)

---

## Microphone

### [Adjusting the Microphone Volume](#)

You can adjust the volume level of the microphone.

You might be looking for the following topics:

[Connecting an External Microphone](#)

---

[▶ Troubleshooting](#)

## How to Use

---

[Parts Description](#)

---

[Setup](#)

---

[Network / Internet](#)

---

[Connections](#)

---

[Settings](#)

---

[View](#)

---

[Playback](#)

---

[Backup / Recovery](#)

---

[Security](#)

---

[Other Operations](#)

---

[Notifications](#)

---

[MONITOR Function](#)

---

## Password

### [Creating/Changing/Removing Your Windows Password](#)

Setting the Windows password allows you to protect your VAIO computer from unauthorized access by making the user enter the password when the computer is turned on or returns from power saving mode to Normal mode.

### [Removing the Power-on Password](#)

If power-on password input for booting up your VAIO computer is no longer necessary, follow these steps to remove the machine password and user password.

### [Setting/Changing the Power-on Password](#)

You can set a password (power-on password) for booting up your VAIO computer, using the BIOS function. Entry of the power-on password will be prompted after the VAIO logo appears to start the computer.

---



[▶ Troubleshooting](#)

## How to Use

---

[Parts Description](#)

---

[Setup](#)

---

[Network / Internet](#)

---

[Connections](#)

---

[Settings](#)

---

[View](#)

---

[Playback](#)

---

[Backup / Recovery](#)

---

[Security](#)

---

[Other Operations](#)

---

[Notifications](#)

---

[MONITOR Function](#)

---

## Power

### [About the Clock / Timers Settings \(MONITOR Function\)](#)

This topic explains clock or timers settings.

### [Notes on Sleep Mode](#)

Read the following precautions before using Sleep mode.

### [Notes on Using the Power Source](#)

Read the following precautions before plugging your VAIO computer into an AC power source.

### [Selecting a Power Plan](#)

Power management helps you set up power plans to suit your requirements for power consumption.

### [Using Sleep Mode](#)

In Sleep mode, all unnecessary devices of your VAIO computer are turned off, though some devices stay on to retain the computer's state including data you are working on. Sleep mode is useful when you take a short rest, for example.

You might be looking for the following topics:

[About the MONITOR Indicator](#)

[Connecting a Power Source](#)

[Restarting Your VAIO Computer](#)

[Shutting Down Your VAIO Computer](#)

[Turning on Your VAIO Computer](#)

---

[▶ Troubleshooting](#)

## How to Use

---

[Parts Description](#)

---

[Setup](#)

---

[Network / Internet](#)

---

[Connections](#)

---

[Settings](#)

---

[View](#)

---

[Playback](#)

---

[Backup / Recovery](#)

---

[Security](#)

---

[Other Operations](#)

---

[Notifications](#)

---

[MONITOR Function](#)

---

## Security

### Updating Your VAIO Computer

Be sure to update your VAIO computer with the following software applications to enhance the computer's efficiency, security, and functionality.

---



[▶ Troubleshooting](#)

**How to Use**

---

Parts Description

---

Setup

---

Network / Internet

---

Connections

---

Settings

---

View

---

Playback

---

Backup / Recovery

---

Security

---

Other Operations

---

Notifications

---

MONITOR Function

---

**Software**

[About Monitor Software version \(MONITOR Function\)](#)

---

[▶ Troubleshooting](#)**How to Use**[Parts Description](#)[Setup](#)[Network / Internet](#)[Connections](#)[Settings](#)[View](#)[Playback](#)[Backup / Recovery](#)[Security](#)[Other Operations](#)[Notifications](#)[MONITOR Function](#)**TV**[About Add Digital Channels \(MONITOR Function\)<TV tuner board installed models>](#)

Adds digital channels.

[About Antenna Connection<TV tuner board installed models>](#)

To watch TV with your VAIO computer, you must first connect the necessary cables, such as for the antenna, etc.

[About Auto Program \(MONITOR Function\)<TV tuner board installed models>](#)

Automatically scans for all available channels and stores them in the TV.

[About Edit Channel Labels \(MONITOR Function\)<TV tuner board installed models>](#)

Edit channel labels to your preference.

[About Show/Hide Channels \(MONITOR Function\)<TV tuner board installed models>](#)

Shows or hides channels when you surf with CH +/- or in the TV channel list.

[About TV Initial Setup \(MONITOR Function\)<TV tuner board installed models>](#)

Runs the initial setup that appeared when you first connected the TV.

[About the Analog Fine Tune Settings \(MONITOR Function\)<TV tuner board installed models>](#)

Allows you to fine-tune analog channels to adjust picture quality.

[About the Cable/Antenna Settings \(MONITOR Function\)<TV tuner board installed models>](#)

Sets the received signal to Cable or Antenna.

[About the Closed Captions \(CC\) Settings \(MONITOR Function\)<TV tuner board installed models>](#)

This setting allows you to select from several closed caption modes.

[About the Info Banner Settings \(MONITOR Function\)<TV tuner board installed models>](#)

Sets the amount of information to display about the currently viewed TV channel and program.

[About the MTS Audio Settings \(MONITOR Function\)<TV tuner board installed models>](#)

Sets audio settings for analog programs.

[About the Parental Lock Settings \(MONITOR Function\)<TV tuner board installed models>](#)

Sets an age restriction for viewing, or blocks specific channels.

[About the Signal Diagnostics Settings \(MONITOR Function\)<TV tuner board installed models>](#)

Displays the diagnostics information for the current signal.

### [Connecting to Standard Cable Access \(CATV\)<TV tuner board installed models>](#)

You can connect your computer to an indoor/outdoor antenna system in CATV mode.

### [Connecting to a Standard Antenna<TV tuner board installed models>](#)

Depending on the type of antenna system in your home, your connection may require a VHF/UHF RF combiner/transformer to connect the computer and the indoor/outdoor antenna system.

### [Running TV Initial Setup<TV tuner board installed models>](#)

To watch TV with your VAIO computer, you must first run TV Initial Setup.

You might be looking for the following topics:

[Quitting TV<TV tuner board installed models>](#)

[Watching TV with Your VAIO Computer<TV tuner board installed models>](#)

---

[▶ Troubleshooting](#)

## How to Use

---

[Parts Description](#)

---

[Setup](#)

---

[Network / Internet](#)

---

[Connections](#)

---

[Settings](#)

---

[View](#)

---

[Playback](#)

---

[Backup / Recovery](#)

---

[Security](#)

---

[Other Operations](#)

---

[Notifications](#)

---

[MONITOR Function](#)

---

## USB

### [About the USB Auto Start Settings \(MONITOR Function\)](#)

Starts a slideshow automatically using photos stored in a connected USB device, such as a digital camera.

You might be looking for the following topics:

[Charging a USB Device](#)[Connecting a USB Device](#)

---

[▶ Troubleshooting](#)

## How to Use

---

[Parts Description](#)

---

[Setup](#)

---

[Network / Internet](#)

---

[Connections](#)

---

[Settings](#)

---

[View](#)

---

[Playback](#)

---

[Backup / Recovery](#)

---

[Security](#)

---

[Other Operations](#)

---

[Notifications](#)

---

[MONITOR Function](#)

---

## VIDEO input

### [Displaying the Menu Screen \(MONITOR Function\)](#)

With the menu screen, you can customize the settings and switch the input source.

### [Registering Your Favorite Items \(Favorites\)](#)

By registering frequently used and recently viewed items, you can access them quickly from a list.

### [Using the Settings Menu \(MONITOR Function\)](#)

With the settings menu, you can customize the settings such as the display and sound settings.

You might be looking for the following topics:

[Accessing Your Favorite Items](#)

---

[▶ Troubleshooting](#)**How to Use**[Parts Description](#)[Setup](#)[Network / Internet](#)[Connections](#)[Settings](#)[View](#)[Playback](#)[Backup / Recovery](#)[Security](#)[Other Operations](#)[Notifications](#)[MONITOR Function](#)**Audio**[About the MTS Audio Settings \(MONITOR Function\)<TV tuner board installed models>](#)

Sets audio settings for analog programs.

[About the Scene Select Settings \(MONITOR Function\)](#)

This setting allows you to optimize picture and sound quality according to the input source.

[About the Sound Adjustments / Sound Settings \(MONITOR Function\)](#)

This topic explains sound adjustments.

[About the Speakers Settings \(MONITOR Function\)](#)

Sets the sound output.

[Adjusting the Microphone Volume](#)

You can adjust the volume level of the microphone.

[Adjusting the Speakers Volume](#)

You can change the volume level of the speakers and headphones.

[Adjusting the Volume in Windows](#)

You can adjust the volume on each software application from the Control Panel window.

[Changing the Sound Output Device](#)

If there is no sound from the device connected to your VAIO computer, you need to change the device for sound output.

[Connecting a High-Quality Digital Sound Output Device between Your VAIO Computer and a TV](#)

You can connect a high-quality home theater receiver or other surround sound decoder devices between your VAIO computer and a TV using an HDMI connection.

[Displaying the Menu Screen \(MONITOR Function\)](#)

With the menu screen, you can customize the settings and switch the input source.

[Enjoying Sounds Only \(Picture Off\)](#)

This feature lets you enjoy sound only with the LCD screen turned off.

[Using the Settings Menu \(MONITOR Function\)](#)

With the settings menu, you can customize the settings such as the display and sound settings.

You might be looking for the following topics:

[Connecting External Speakers or Headphones](#)[Connecting an External Microphone](#)[Turning Off the LCD Screen](#)



[▶ Troubleshooting](#)

## How to Use

---

[Parts Description](#)

---

[Setup](#)

---

[Network / Internet](#)

---

[Connections](#)

---

[Settings](#)

---

[View](#)

---

[Playback](#)

---

[Backup / Recovery](#)

---

[Security](#)

---

[Other Operations](#)

---

[Notifications](#)

---

[MONITOR Function](#)

---

## Button

### [Changing the Button Assignment \(VAIO Button\)](#)

You can change the current task assigned to the VAIO button. [\[Details\]](#)

You might be looking for the following topics:

[About the ASSIST Button](#)

---

[▶ Troubleshooting](#)

## How to Use

---

[Parts Description](#)

---

[Setup](#)

---

[Network / Internet](#)

---

[Connections](#)

---

[Settings](#)

---

[View](#)

---

[Playback](#)

---

[Backup / Recovery](#)

---

[Security](#)

---

[Other Operations](#)

---

[Notifications](#)

---

[MONITOR Function](#)

---

## Camera

### [Using the Built-in Camera<Built-in camera equipped models>](#)

If your VAIO computer is equipped with a built-in camera, you can make a video call through the Internet using communication software, such as Windows Live Messenger. For detailed information on how to use the software, refer to the help file included with the software.

You might be looking for the following topics:

[Notes on the Built-in Camera<Built-in camera equipped models>](#)

---

[▶ Troubleshooting](#)

## How to Use

[Parts Description](#)[Setup](#)[Network / Internet](#)[Connections](#)[Settings](#)[View](#)[Playback](#)[Backup / Recovery](#)[Security](#)[Other Operations](#)[Notifications](#)[MONITOR Function](#)

## HDMI

### [About HDMI Settings / HDMI Setup \(MONITOR Function\)](#)

This topic explains the settings for the “Control for HDMI” function.

### [Changing the Resolution \(Size\) of the Screen Image on an HDMI-Connected Device](#)

You can change the screen resolution or size of your VAIO computer's screen image displayed on an external display, such as a TV, connected to the computer with an HDMI cable (not supplied).

### [Connecting a TV with an HDMI Input Port](#)

You can connect a TV with an HDMI input port to your VAIO computer with an HDMI cable (not supplied).

### [Operating “Control for HDMI”-Compatible Equipment](#)

With the “Control for HDMI” function, you can operate “Control for HDMI”-compatible equipment that is connected to your VAIO computer.

You might be looking for the following topics:

[About “BRAVIA” Sync](#)[Connecting a VCR or DVD Player](#)[Connecting an Audio System](#)

[▶ Troubleshooting](#)

## How to Use

---

[Parts Description](#)

---

[Setup](#)

---

[Network / Internet](#)

---

[Connections](#)

---

[Settings](#)

---

[View](#)

---

[Playback](#)

---

[Backup / Recovery](#)

---

[Security](#)

---

[Other Operations](#)

---

[Notifications](#)

---

[MONITOR Function](#)

---

## Internet

### [About Network Setup \(MONITOR Function\)](#)

This topic explains the network setting of the MONITOR ONLY LAN port.

You might be looking for the following topics:

[About a Security Key for a Wireless LAN](#)[About the Internet Connection Services](#)[About the Network \(LAN\)](#)[About the Wireless LAN Standards](#)[Before Using the Wireless LAN](#)[Connecting to the Internet with a Wired Connection](#)[Launching the Web Browser \(WEB Button\)](#)[Notes on Using the Wireless LAN Function](#)[Starting Wireless LAN Communications](#)[Stopping Wireless LAN Communications](#)[Using the Antivirus Software for Your VAIO Computer](#)

[▶ Troubleshooting](#)

## How to Use

---

[Parts Description](#)

---

[Setup](#)

---

[Network / Internet](#)

---

[Connections](#)

---

[Settings](#)

---

[View](#)

---

[Playback](#)

---

[Backup / Recovery](#)

---

[Security](#)

---

[Other Operations](#)

---

[Notifications](#)

---

[MONITOR Function](#)

---

## Memory module

### [Viewing the System Information](#)

You can view the system information of your VAIO computer.

You might be looking for the following topics:

[Adding and Removing Memory Modules](#)

[Notes on Adding and Removing Memory Modules](#)

---

[▶ Troubleshooting](#)

## How to Use

---

[Parts Description](#)

---

[Setup](#)

---

[Network / Internet](#)

---

[Connections](#)

---

[Settings](#)

---

[View](#)

---

[Playback](#)

---

[Backup / Recovery](#)

---

[Security](#)

---

[Other Operations](#)

---

[Notifications](#)

---

[MONITOR Function](#)

---

## Optical digital output

### [Connecting a High-Quality Digital Sound Output Device between Your VAIO Computer and a TV](#)

You can connect a high-quality home theater receiver or other surround sound decoder devices between your VAIO computer and a TV using an HDMI connection.

---

[▶ Troubleshooting](#)**How to Use**[Parts Description](#)[Setup](#)[Network / Internet](#)[Connections](#)[Settings](#)[View](#)[Playback](#)[Backup / Recovery](#)[Security](#)[Other Operations](#)[Notifications](#)[MONITOR Function](#)**Peripheral device**[About HDMI Settings / HDMI Setup \(MONITOR Function\)](#)

This topic explains the settings for the “Control for HDMI” function.

[About the USB Auto Start Settings \(MONITOR Function\)](#)

Starts a slideshow automatically using photos stored in a connected USB device, such as a digital camera.

[Changing the Sound Output Device](#)

If there is no sound from the device connected to your VAIO computer, you need to change the device for sound output.

[Connecting a High-Quality Digital Sound Output Device between Your VAIO Computer and a TV](#)

You can connect a high-quality home theater receiver or other surround sound decoder devices between your VAIO computer and a TV using an HDMI connection.

[Connecting a TV with an HDMI Input Port](#)

You can connect a TV with an HDMI input port to your VAIO computer with an HDMI cable (not supplied).

[Displaying the Menu Screen \(MONITOR Function\)](#)

With the menu screen, you can customize the settings and switch the input source.

[Notes on the LCD screen](#)

Read the following precautions for correct use of the LCD screen.

[Operating “Control for HDMI”-Compatible Equipment](#)

With the “Control for HDMI” function, you can operate “Control for HDMI”-compatible equipment that is connected to your VAIO computer.

[Selecting Display Modes](#)

You can switch the display output between the computer screen and an external display connected to your VAIO computer.

[Using the Multiple Monitors Function](#)

The Multiple Monitors function allows you to distribute portions of your desktop across separate displays.

[Using the Settings Menu \(MONITOR Function\)](#)

With the settings menu, you can customize the settings such as the display and sound settings.

You might be looking for the following topics:

[About Media Remote](#)[About “BRAVIA” Sync](#)[Connecting a VCR or DVD Player](#)[Connecting an Audio System](#)[Connecting an External Microphone](#)[Connecting to a Home Network](#)[Enjoying Sounds from Connected Audio System](#)





[▶ Troubleshooting](#)

## How to Use

---

[Parts Description](#)

---

[Setup](#)

---

[Network / Internet](#)

---

[Connections](#)

---

[Settings](#)

---

[View](#)

---

[Playback](#)

---

[Backup / Recovery](#)

---

[Security](#)

---

[Other Operations](#)

---

[Notifications](#)

---

[MONITOR Function](#)

---

## Remote commander

### [Replacing the AA Battery of the Remote Commander<TV tuner board installed models>](#)

If the remote commander does not operate properly, replace the batteries.

You might be looking for the following topics:

[Parts and Controls of the Remote Commander<TV tuner board installed models>](#)

---

[▶ Troubleshooting](#)

## How to Use

---

[Parts Description](#)

---

[Setup](#)

---

[Network / Internet](#)

---

[Connections](#)

---

[Settings](#)

---

[View](#)

---

[Playback](#)

---

[Backup / Recovery](#)

---

[Security](#)

---

[Other Operations](#)

---

[Notifications](#)

---

[MONITOR Function](#)

---

## Service and support

### [Keeping Your VAIO Computer in Optimum Condition \(VAIO Care\)](#)

With VAIO Care, you can perform the following operations to keep your VAIO computer running at an optimum level.

### [Updating Your VAIO Computer](#)

Be sure to update your VAIO computer with the following software applications to enhance the computer's efficiency, security, and functionality.

### [Using VAIO Update](#)

VAIO Update provides a service that informs you of available update information, such as important notices or update programs, to keep your VAIO computer up to date.

You might be looking for the following topics:

[About Online Support Website](#)[Solving Common Problems with Your VAIO Computer](#)

---

[▶ Troubleshooting](#)

## How to Use

---

[Parts Description](#)

---

[Setup](#)

---

[Network / Internet](#)

---

[Connections](#)

---

[Settings](#)

---

[View](#)

---

[Playback](#)

---

[Backup / Recovery](#)

---

[Security](#)

---

[Other Operations](#)

---

[Notifications](#)

---

[MONITOR Function](#)

---

## Speakers

### [About the Speakers Settings \(MONITOR Function\)](#)

Sets the sound output.

### [Adjusting the Speakers Volume](#)

You can change the volume level of the speakers and headphones.

You might be looking for the following topics:

[Connecting External Speakers or Headphones](#)

---

[▶ Troubleshooting](#)

## How to Use

---

[Parts Description](#)

---

[Setup](#)

---

[Network / Internet](#)

---

[Connections](#)

---

[Settings](#)

---

[View](#)

---

[Playback](#)

---

[Backup / Recovery](#)

---

[Security](#)

---

[Other Operations](#)

---

[Notifications](#)

---

[MONITOR Function](#)

---

## Touch panel

### [Enable/Disable the Touch Screen<Touch screen equipped models>](#)

By default, the touch screen of the VAIO computer is enabled. To disable/enable the touch screen, do the following:

### [Enlarging the Text Size \(DPI\)<Touch screen equipped models>](#)

You can change the DPI to enlarge the font size, making it easier to touch specific text.

### [How to Use the Touch Screen<Touch screen equipped models>](#)

You can tap the touch screen or make a simple motion with your fingers to operate the VAIO computer.

### [Multiple Touch Screen Operation](#)

In the VAIO Touch Portal, you can choose a wide variety of software that can be enjoyed with touch screen operation.

### [Notes on Using the Touch Screen<Touch screen equipped models>](#)

Before using the touch screen, read the following precautions for correct use.

You might be looking for the following topics:

[About the Touch Screen<Touch screen equipped models>](#)

---

[▶ Troubleshooting](#)**How to Use**[Parts Description](#)[Setup](#)[Network / Internet](#)[Connections](#)**[Settings](#)**[View](#)[Playback](#)[Backup / Recovery](#)[Security](#)[Other Operations](#)[Notifications](#)[MONITOR Function](#)**VAIO computer**[About Factory Setting \(MONITOR Function\)](#)

Returns the current settings to the initial settings.

[About the Clock / Timers Settings \(MONITOR Function\)](#)

This topic explains clock or timers settings.

[About the Front Panel Illumination Settings \(MONITOR Function\)](#)

Turns the logo lamp on the front of your VAIO computer on or off.

[Booting Your VAIO Computer from External Devices](#)

You can boot your VAIO computer from external devices, such as an optical disc drive or a USB floppy disk drive, by using the BIOS function.

[Customizing Your VAIO Computer](#)

VAIO Control Center allows you to access system information and to change settings of various kinds of functions such as display and sounds.

[Displaying the Menu Screen \(MONITOR Function\)](#)

With the menu screen, you can customize the settings and switch the input source.

[Keeping Your VAIO Computer in Optimum Condition \(VAIO Care\)](#)

With VAIO Care, you can perform the following operations to keep your VAIO computer running at an optimum level.

[Updating Your VAIO Computer](#)

Be sure to update your VAIO computer with the following software applications to enhance the computer's efficiency, security, and functionality.

[Using VAIO Update](#)

VAIO Update provides a service that informs you of available update information, such as important notices or update programs, to keep your VAIO computer up to date.

[Using the Settings Menu \(MONITOR Function\)](#)

With the settings menu, you can customize the settings such as the display and sound settings.

[Viewing the System Information](#)

You can view the system information of your VAIO computer.

You might be looking for the following topics:

[About the ASSIST Button](#)[About the MONITOR Indicator](#)[Adding and Removing Memory Modules](#)[Checking Supplied Items](#)[Notes on Adding and Removing Memory Modules](#)[Parts and Controls on the Back](#)[Parts and Controls on the Bottom](#)[Parts and Controls on the Front](#)[Parts and Controls on the Sides](#)



[▶ Troubleshooting](#)

## How to Use

---

[Parts Description](#)

---

[Setup](#)

---

[Network / Internet](#)

---

[Connections](#)

---

[Settings](#)[View](#)[Playback](#)

---

[Backup / Recovery](#)

---

[Security](#)

---

[Other Operations](#)

---

[Notifications](#)

---

[MONITOR Function](#)

---

## Antenna

### [About Antenna Connection<TV tuner board installed models>](#)

To watch TV with your VAIO computer, you must first connect the necessary cables, such as for the antenna, etc.

### [Connecting to Standard Cable Access \(CATV\)<TV tuner board installed models>](#)

You can connect your computer to an indoor/outdoor antenna system in CATV mode.

### [Connecting to a Standard Antenna<TV tuner board installed models>](#)

Depending on the type of antenna system in your home, your connection may require a VHF/UHF RF combiner/transformer to connect the computer and the indoor/outdoor antenna system.

You might be looking for the following topics:

[About the Cable/Antenna Settings \(MONITOR Function\)<TV tuner board installed models>](#)

---

[▶ Troubleshooting](#)

## How to Use

---

[Parts Description](#)

---

[Setup](#)

---

[Network / Internet](#)

---

[Connections](#)

---

[Settings](#)

---

[View](#)

---

[Playback](#)

---

[Backup / Recovery](#)

---

[Security](#)

---

[Other Operations](#)

---

[Notifications](#)

---

[MONITOR Function](#)

---

## Peripheral device

### [Viewing Pictures from Connected Equipment](#)

Switch the input selector of your VAIO computer so that the signal from a connected VCR or DVD player appears on the computer screen.

You might be looking for the following topics:

[About HDMI Settings / HDMI Setup \(MONITOR Function\)](#)

[About Media Remote](#)

[About the USB Auto Start Settings \(MONITOR Function\)](#)

[About "BRAVIA" Sync](#)

[Changing the Sound Output Device](#)

[Connecting a High-Quality Digital Sound Output Device between Your VAIO Computer and a TV](#)

[Connecting a TV with an HDMI Input Port](#)

[Connecting a VCR or DVD Player](#)

[Connecting an Audio System](#)

[Connecting an External Microphone](#)

[Connecting to a Home Network](#)

[Displaying the Menu Screen \(MONITOR Function\)](#)

[Enjoying Sounds from Connected Audio System](#)

[Notes on the LCD screen](#)

[Operating "Control for HDMI"-Compatible Equipment](#)

[Selecting Display Modes](#)

[Using the Multiple Monitors Function](#)

[Using the Settings Menu \(MONITOR Function\)](#)

---



[▶ Troubleshooting](#)**How to Use**[Parts Description](#)[Setup](#)[Network / Internet](#)[Connections](#)[Settings](#)[View](#)[Playback](#)[Backup / Recovery](#)[Security](#)[Other Operations](#)[Notifications](#)[MONITOR Function](#)**TV**[About Antenna Connection<TV tuner board installed models>](#)

To watch TV with your VAIO computer, you must first connect the necessary cables, such as for the antenna, etc.

[Connecting to Standard Cable Access \(CATV\)<TV tuner board installed models>](#)

You can connect your computer to an indoor/outdoor antenna system in CATV mode.

[Connecting to a Standard Antenna<TV tuner board installed models>](#)

Depending on the type of antenna system in your home, your connection may require a VHF/UHF RF combiner/transformer to connect the computer and the indoor/outdoor antenna system.

[Quitting TV<TV tuner board installed models>](#)

Quit showing TV with your VAIO Computer.

[Watching TV with Your VAIO Computer<TV tuner board installed models>](#)

You can begin watching TV programs quickly without starting Windows.

You might be looking for the following topics:

[About Add Digital Channels \(MONITOR Function\)<TV tuner board installed models>](#)

[About Auto Program \(MONITOR Function\)<TV tuner board installed models>](#)

[About Edit Channel Labels \(MONITOR Function\)<TV tuner board installed models>](#)

[About Show/Hide Channels \(MONITOR Function\)<TV tuner board installed models>](#)

[About TV Initial Setup \(MONITOR Function\)<TV tuner board installed models>](#)

[About the Analog Fine Tune Settings \(MONITOR Function\)<TV tuner board installed models>](#)

[About the Cable/Antenna Settings \(MONITOR Function\)<TV tuner board installed models>](#)

[About the Closed Captions \(CC\) Settings \(MONITOR Function\)<TV tuner board installed models>](#)

[About the Info Banner Settings \(MONITOR Function\)<TV tuner board installed models>](#)

[About the MTS Audio Settings \(MONITOR Function\)<TV tuner board installed models>](#)

[About the Parental Lock Settings \(MONITOR Function\)<TV tuner board installed models>](#)

[About the Signal Diagnostics Settings \(MONITOR Function\)<TV tuner board installed models>](#)

[Running TV Initial Setup<TV tuner board installed models>](#)

[▶ Troubleshooting](#)

## How to Use

---

[Parts Description](#)

---

[Setup](#)

---

[Network / Internet](#)

---

[Connections](#)

---

[Settings](#)

---

[View](#)

---

[Playback](#)

---

[Backup / Recovery](#)

---

[Security](#)

---

[Other Operations](#)

---

[Notifications](#)

---

[MONITOR Function](#)

---

## Video

### [Notes on Playing Photos / Music / Videos without Starting Windows](#)

These notes explain how to play contents stored in connected USB device without starting Windows, and playable data formats.

### [Playing Photos / Music / Videos Stored in the Connecting USB Device without Starting Windows](#)

Plays photos/music/videos on the screen by connecting a Sony digital still camera or other USB-compatible device.

---

[▶ Troubleshooting](#)

## How to Use

---

[Parts Description](#)

---

[Setup](#)

---

[Network / Internet](#)

---

[Connections](#)

---

[Settings](#)

---

[View](#)

---

[Playback](#)

---

[Backup / Recovery](#)

---

[Security](#)

---

[Other Operations](#)

---

[Notifications](#)

---

[MONITOR Function](#)

---

## Music

### [Notes on Playing Photos / Music / Videos without Starting Windows](#)

These notes explain how to play contents stored in connected USB device without starting Windows, and playable data formats.

### [Playing Photos / Music / Videos Stored in the Connecting USB Device without Starting Windows](#)

Plays photos/music/videos on the screen by connecting a Sony digital still camera or other USB-compatible device.

---

[▶ Troubleshooting](#)

## How to Use

---

[Parts Description](#)

---

[Setup](#)

---

[Network / Internet](#)

---

[Connections](#)

---

[Settings](#)

---

[View](#)

---

[Playback](#)

---

[Backup / Recovery](#)

---

[Security](#)

---

[Other Operations](#)

---

[Notifications](#)

---

[MONITOR Function](#)

---

## Photo

### [Notes on Playing Photos / Music / Videos without Starting Windows](#)

These notes explain how to play contents stored in connected USB device without starting Windows, and playable data formats.

### [Playing Photos / Music / Videos Stored in the Connecting USB Device without Starting Windows](#)

Plays photos/music/videos on the screen by connecting a Sony digital still camera or other USB-compatible device.

---

[▶ Troubleshooting](#)

## How to Use

---

[Parts Description](#)

---

[Setup](#)

---

[Network / Internet](#)

---

[Connections](#)

---

[Settings](#)

---

[View](#)

---

[Playback](#)

---

[Backup / Recovery](#)

---

[Security](#)

---

[Other Operations](#)

---

[Notifications](#)

---

[MONITOR Function](#)

---

## VIDEO input

### [Accessing Your Favorite Items](#)

Access your favorite items registered on a list.

You might be looking for the following topics:

[Displaying the Menu Screen \(MONITOR Function\)](#)

[Registering Your Favorite Items \(Favorites\)](#)

[Using the Settings Menu \(MONITOR Function\)](#)

---

[▶ Troubleshooting](#)

## How to Use

---

[Parts Description](#)

---

[Setup](#)

---

[Network / Internet](#)

---

[Connections](#)

---

[Settings](#)

---

[View](#)[Playback](#)[Backup / Recovery](#)

---

[Security](#)

---

[Other Operations](#)

---

[Notifications](#)

---

[MONITOR Function](#)

---

## CD/DVD/BD

### [About Region Codes<Optical disc drive equipped models>](#)

The following is a list of DVD region codes indicating playable regions of DVD media.

### [Inserting/Removing a Disc<Optical disc drive equipped models>](#)

Insert/remove a disc to/from your VAIO computer that is turned on.

### [Supported Discs<Optical disc drive equipped models>](#)

This topic explains media types that are playable/recordable on your VAIO computer.

You might be looking for the following topics:

[Booting Your VAIO Computer from External Devices](#)[Connecting an External DVD Drive](#)[Handling Discs<Optical disc drive equipped models>](#)[Notes on Using Discs<Optical disc drive equipped models>](#)

[▶ Troubleshooting](#)

## How to Use

---

[Parts Description](#)

---

[Setup](#)

---

[Network / Internet](#)

---

[Connections](#)

---

[Settings](#)

---

[View](#)[Playback](#)[Backup / Recovery](#)

---

[Security](#)

---

[Other Operations](#)

---

[Notifications](#)

---

[MONITOR Function](#)

---

## Peripheral device

### [Viewing Pictures from Connected Equipment](#)

Switch the input selector of your VAIO computer so that the signal from a connected VCR or DVD player appears on the computer screen.

You might be looking for the following topics:

[About HDMI Settings / HDMI Setup \(MONITOR Function\)](#)

[About Media Remote](#)

[About the USB Auto Start Settings \(MONITOR Function\)](#)

[About "BRAVIA" Sync](#)

[Changing the Sound Output Device](#)

[Connecting a High-Quality Digital Sound Output Device between Your VAIO Computer and a TV](#)

[Connecting a TV with an HDMI Input Port](#)

[Connecting a VCR or DVD Player](#)

[Connecting an Audio System](#)

[Connecting an External Microphone](#)

[Connecting to a Home Network](#)

[Displaying the Menu Screen \(MONITOR Function\)](#)

[Enjoying Sounds from Connected Audio System](#)

[Notes on the LCD screen](#)

[Operating "Control for HDMI"-Compatible Equipment](#)

[Selecting Display Modes](#)

[Using the Multiple Monitors Function](#)

[Using the Settings Menu \(MONITOR Function\)](#)

---

[▶ Troubleshooting](#)

## How to Use

---

[Parts Description](#)

---

[Setup](#)

---

[Network / Internet](#)

---

[Connections](#)

---

[Settings](#)

---

[View](#)

---

[Playback](#)

---

[Backup / Recovery](#)

---

[Security](#)

---

[Other Operations](#)

---

[Notifications](#)

---

[MONITOR Function](#)

---

## Video

### [Notes on Playing Photos / Music / Videos without Starting Windows](#)

These notes explain how to play contents stored in connected USB device without starting Windows, and playable data formats.

### [Playing Photos / Music / Videos Stored in the Connecting USB Device without Starting Windows](#)

Plays photos/music/videos on the screen by connecting a Sony digital still camera or other USB-compatible device.

---



[▶ Troubleshooting](#)

## How to Use

---

[Parts Description](#)

---

[Setup](#)

---

[Network / Internet](#)

---

[Connections](#)

---

[Settings](#)

---

[View](#)

---

[Playback](#)

---

[Backup / Recovery](#)

---

[Security](#)

---

[Other Operations](#)

---

[Notifications](#)

---

[MONITOR Function](#)

---

## Music

### [Notes on Playing Photos / Music / Videos without Starting Windows](#)

These notes explain how to play contents stored in connected USB device without starting Windows, and playable data formats.

### [Playing Photos / Music / Videos Stored in the Connecting USB Device without Starting Windows](#)

Plays photos/music/videos on the screen by connecting a Sony digital still camera or other USB-compatible device.

---

[▶ Troubleshooting](#)

## How to Use

---

[Parts Description](#)

---

[Setup](#)

---

[Network / Internet](#)

---

[Connections](#)

---

[Settings](#)

---

[View](#)

---

[Playback](#)

---

[Backup / Recovery](#)

---

[Security](#)

---

[Other Operations](#)

---

[Notifications](#)

---

[MONITOR Function](#)

---

## Photo

### [Notes on Playing Photos / Music / Videos without Starting Windows](#)

These notes explain how to play contents stored in connected USB device without starting Windows, and playable data formats.

### [Playing Photos / Music / Videos Stored in the Connecting USB Device without Starting Windows](#)

Plays photos/music/videos on the screen by connecting a Sony digital still camera or other USB-compatible device.

---

[▶ Troubleshooting](#)

## How to Use

---

[Parts Description](#)

---

[Setup](#)

---

[Network / Internet](#)

---

[Connections](#)

---

[Settings](#)

---

[View](#)

---

[Playback](#)

---

[Backup / Recovery](#)

---

[Security](#)

---

[Other Operations](#)

---

[Notifications](#)

---

[MONITOR Function](#)

---

## BIOS

### [Booting Your VAIO Computer from External Devices](#)

You can boot your VAIO computer from external devices, such as an optical disc drive or a USB floppy disk drive, by using the BIOS function.

You might be looking for the following topics:

[Removing the Power-on Password](#)[Setting/Changing the Power-on Password](#)

---

[▶ Troubleshooting](#)

## How to Use

[Parts Description](#)[Setup](#)[Network / Internet](#)[Connections](#)[Settings](#)[View](#)[Playback](#)[Backup / Recovery](#)[Security](#)[Other Operations](#)[Notifications](#)[MONITOR Function](#)

## Built-in storage device

### [Checking the Volume of the Recovery Area](#)

Your built-in storage device contains the recovery area where the data for the system recovery is stored.

### [Creating Other Drives \(Modifying Partitions\)](#)

Partitions are divided areas on your built-in storage device. Dividing the built-in storage device into more than one partition may have various advantages, such as separating the system files from your data files.

### [Creating Partitions during Recovery](#)

This topic describes how to create partitions.

### [Creating Partitions in Windows](#)

The Windows feature allows you to create a partition without recovering your VAIO computer system.

### [Removing Recovery Contents to Free up Disk Space](#)

Your built-in storage device contains the recovery area where the data for system recovery is stored. If your VAIO computer includes a solid state drive (SSD), you might want to minimize the recovery area by removing such data.

[▶ Troubleshooting](#)

## How to Use

---

[Parts Description](#)

---

[Setup](#)

---

[Network / Internet](#)

---

[Connections](#)

---

[Settings](#)

---

[View](#)

---

[Playback](#)

---

[Backup / Recovery](#)

---

[Security](#)

---

[Other Operations](#)

---

[Notifications](#)

---

[MONITOR Function](#)

---

## CD/DVD/BD

### [Booting Your VAIO Computer from External Devices](#)

You can boot your VAIO computer from external devices, such as an optical disc drive or a USB floppy disk drive, by using the BIOS function.

You might be looking for the following topics:

[About Region Codes<Optical disc drive equipped models>](#)

[Connecting an External DVD Drive](#)

[Handling Discs<Optical disc drive equipped models>](#)

[Inserting/Removing a Disc<Optical disc drive equipped models>](#)

[Notes on Using Discs<Optical disc drive equipped models>](#)

[Supported Discs<Optical disc drive equipped models>](#)

---

[▶ Troubleshooting](#)

## How to Use

[Parts Description](#)[Setup](#)[Network / Internet](#)[Connections](#)[Settings](#)[View](#)[Playback](#)[Backup / Recovery](#)[Security](#)[Other Operations](#)[Notifications](#)[MONITOR Function](#)

## Recovery

### [About Recovery](#)

Recovery is the process of restoring your VAIO computer back to its original factory condition.

### [About the ASSIST Button](#)

Press the ASSIST button to perform regular maintenance of your VAIO computer or to solve problems you might encounter when using the computer.

### [Checking the Volume of the Recovery Area](#)

Your built-in storage device contains the recovery area where the data for the system recovery is stored.

### [Creating Recovery Media](#)

Follow the instructions below to create Recovery Media.

### [Notes on Recovery](#)

Read the following notes thoroughly before recovering your VAIO computer.

### [Recovering from Recovery Media](#)

If the recovery area data has been corrupted or erased, you can use Recovery Media to recover your VAIO computer. However, it takes longer time to recover using Recovery Media than using the recovery area.

### [Recovering from the Recovery Area](#)

Recovery from the recovery area on the built-in storage device is faster than recovery using Recovery Media.

### [Removing Recovery Contents to Free up Disk Space](#)

Your built-in storage device contains the recovery area where the data for system recovery is stored. If your VAIO computer includes a solid state drive (SSD), you might want to minimize the recovery area by removing such data.

[▶ Troubleshooting](#)**How to Use**[Parts Description](#)[Setup](#)[Network / Internet](#)[Connections](#)[Settings](#)[View](#)[Playback](#)[Backup / Recovery](#)[Security](#)[Other Operations](#)[Notifications](#)[MONITOR Function](#)**VAIO computer**[About the ASSIST Button](#)

Press the ASSIST button to perform regular maintenance of your VAIO computer or to solve problems you might encounter when using the computer.

[Booting Your VAIO Computer from External Devices](#)

You can boot your VAIO computer from external devices, such as an optical disc drive or a USB floppy disk drive, by using the BIOS function.

[Keeping Your VAIO Computer in Optimum Condition \(VAIO Care\)](#)

With VAIO Care, you can perform the following operations to keep your VAIO computer running at an optimum level.

You might be looking for the following topics:

[About Factory Setting \(MONITOR Function\)](#)[About the Clock / Timers Settings \(MONITOR Function\)](#)[About the Front Panel Illumination Settings \(MONITOR Function\)](#)[About the MONITOR Indicator](#)[Adding and Removing Memory Modules](#)[Checking Supplied Items](#)[Customizing Your VAIO Computer](#)[Displaying the Menu Screen \(MONITOR Function\)](#)[Notes on Adding and Removing Memory Modules](#)[Parts and Controls on the Back](#)[Parts and Controls on the Bottom](#)[Parts and Controls on the Front](#)[Parts and Controls on the Sides](#)[Preparing for Wall Mounting](#)[Setting Up an Appropriate Work Environment](#)[Updating Your VAIO Computer](#)[Using VAIO Update](#)[Using the Settings Menu \(MONITOR Function\)](#)[Viewing the System Information](#)

[▶ Troubleshooting](#)

## How to Use

[Parts Description](#)[Setup](#)[Network / Internet](#)[Connections](#)[Settings](#)[View](#)[Playback](#)[Backup / Recovery](#)[Security](#)[Other Operations](#)[Notifications](#)[MONITOR Function](#)

## Backup

### [About Backup](#)

The backup process creates a backup copy of your data stored on the built-in storage device and saves it to another location.

### [About Types of Backup](#)

You can use the Windows Backup and Restore feature to back up your valuable data.

### [Backing Up Your Data when You cannot Start Windows](#)

If you cannot start Windows, back up your data with VAIO Care Rescue.

### [Creating a Restore Point](#)

A restore point enables you to restore your computer system files to a previous state, depending on when the restore point was created.

### [Restoring System Files Using the Restore Point when You cannot Start Windows](#)

When you cannot start Windows, follow these steps to restore computer system files.

### [Restoring Your Data with VAIO Data Restore Tool](#)

If you backed up files previously using VAIO Care Rescue, use VAIO Data Restore Tool to restore these files.



[▶ Troubleshooting](#)

## How to Use

---

[Parts Description](#)

---

[Setup](#)

---

[Network / Internet](#)

---

[Connections](#)

---

[Settings](#)

---

[View](#)

---

[Playback](#)

---

[Backup / Recovery](#)

---

[Security](#)

---

[Other Operations](#)

---

[Notifications](#)

---

[MONITOR Function](#)

---

## Button

### [About the ASSIST Button](#)

Press the ASSIST button to perform regular maintenance of your VAIO computer or to solve problems you might encounter when using the computer.

You might be looking for the following topics:

[Changing the Button Assignment \(VAIO Button\)](#)

---

[▶ Troubleshooting](#)

## How to Use

---

[Parts Description](#)

---

[Setup](#)

---

[Network / Internet](#)

---

[Connections](#)

---

[Settings](#)

---

[View](#)

---

[Playback](#)

---

[Backup / Recovery](#)

---

[Security](#)

---

[Other Operations](#)

---

[Notifications](#)

---

[MONITOR Function](#)

---

## Partition

### [Creating Other Drives \(Modifying Partitions\)](#)

Partitions are divided areas on your built-in storage device. Dividing the built-in storage device into more than one partition may have various advantages, such as separating the system files from your data files.

### [Creating Partitions during Recovery](#)

This topic describes how to create partitions.

### [Creating Partitions in Windows](#)

The Windows feature allows you to create a partition without recovering your VAIO computer system.

---

[▶ Troubleshooting](#)

## How to Use

---

[Parts Description](#)

---

[Setup](#)

---

[Network / Internet](#)

---

[Connections](#)

---

[Settings](#)

---

[View](#)

---

[Playback](#)

---

[Backup / Recovery](#)

---

[Security](#)

---

[Other Operations](#)

---

[Notifications](#)

---

[MONITOR Function](#)

---

## Service and support

### [Keeping Your VAIO Computer in Optimum Condition \(VAIO Care\)](#)

With VAIO Care, you can perform the following operations to keep your VAIO computer running at an optimum level.

You might be looking for the following topics:

[About Online Support Website](#)[Solving Common Problems with Your VAIO Computer](#)[Updating Your VAIO Computer](#)[Using VAIO Update](#)

---

[▶ Troubleshooting](#)

## How to Use

---

[Parts Description](#)

---

[Setup](#)

---

[Network / Internet](#)

---

[Connections](#)

---

[Settings](#)

---

[View](#)

---

[Playback](#)

---

[Backup / Recovery](#)

---

[Security](#)

---

[Other Operations](#)

---

[Notifications](#)

---

[MONITOR Function](#)

---

## BIOS

### [Removing the Power-on Password](#)

If power-on password input for booting up your VAIO computer is no longer necessary, follow these steps to remove the machine password and user password.

### [Setting/Changing the Power-on Password](#)

You can set a password (power-on password) for booting up your VAIO computer, using the BIOS function. Entry of the power-on password will be prompted after the VAIO logo appears to start the computer.

You might be looking for the following topics:

[Booting Your VAIO Computer from External Devices](#)

---

[▶ Troubleshooting](#)

## How to Use

---

[Parts Description](#)

---

[Setup](#)

---

[Network / Internet](#)

---

[Connections](#)

---

[Settings](#)

---

[View](#)

---

[Playback](#)

---

[Backup / Recovery](#)

---

[Security](#)

---

[Other Operations](#)

---

[Notifications](#)

---

[MONITOR Function](#)

---

## Password

### [Creating/Changing/Removing Your Windows Password](#)

Setting the Windows password allows you to protect your VAIO computer from unauthorized access by making the user enter the password when the computer is turned on or returns from power saving mode to Normal mode.

### [Removing the Power-on Password](#)

If power-on password input for booting up your VAIO computer is no longer necessary, follow these steps to remove the machine password and user password.

### [Setting/Changing the Power-on Password](#)

You can set a password (power-on password) for booting up your VAIO computer, using the BIOS function. Entry of the power-on password will be prompted after the VAIO logo appears to start the computer.

---

[▶ Troubleshooting](#)

## How to Use

---

[Parts Description](#)

---

[Setup](#)

---

[Network / Internet](#)

---

[Connections](#)

---

[Settings](#)

---

[View](#)

---

[Playback](#)

---

[Backup / Recovery](#)

---

[Security](#)

---

[Other Operations](#)

---

[Notifications](#)

---

[MONITOR Function](#)

---

## VAIO computer

### [Keeping Your VAIO Computer in Optimum Condition \(VAIO Care\)](#)

With VAIO Care, you can perform the following operations to keep your VAIO computer running at an optimum level.

### [Using VAIO Update](#)

VAIO Update provides a service that informs you of available update information, such as important notices or update programs, to keep your VAIO computer up to date.

You might be looking for the following topics:

[About Factory Setting \(MONITOR Function\)](#)[About the ASSIST Button](#)[About the Clock / Timers Settings \(MONITOR Function\)](#)[About the Front Panel Illumination Settings \(MONITOR Function\)](#)[About the MONITOR Indicator](#)[Adding and Removing Memory Modules](#)[Booting Your VAIO Computer from External Devices](#)[Checking Supplied Items](#)[Customizing Your VAIO Computer](#)[Displaying the Menu Screen \(MONITOR Function\)](#)[Notes on Adding and Removing Memory Modules](#)[Parts and Controls on the Back](#)[Parts and Controls on the Bottom](#)[Parts and Controls on the Front](#)[Parts and Controls on the Sides](#)[Preparing for Wall Mounting](#)[Setting Up an Appropriate Work Environment](#)[Updating Your VAIO Computer](#)[Using the Settings Menu \(MONITOR Function\)](#)[Viewing the System Information](#)

[▶ Troubleshooting](#)

## How to Use

---

[Parts Description](#)

---

[Setup](#)

---

[Network / Internet](#)

---

[Connections](#)

---

[Settings](#)

---

[View](#)

---

[Playback](#)

---

[Backup / Recovery](#)

---

[Security](#)

---

[Other Operations](#)

---

[Notifications](#)

---

[MONITOR Function](#)

---

## Internet

### [Launching the Web Browser \(WEB Button\)](#)

By pressing the WEB button, you can launch the default web browser.

### [Using the Antivirus Software for Your VAIO Computer](#)

Protect your VAIO computer against computer viruses by using the antivirus software.

You might be looking for the following topics:

[About Network Setup \(MONITOR Function\)](#)[About a Security Key for a Wireless LAN](#)[About the Internet Connection Services](#)[About the Network \(LAN\)](#)[About the Wireless LAN Standards](#)[Before Using the Wireless LAN](#)[Connecting to the Internet with a Wired Connection](#)[Notes on Using the Wireless LAN Function](#)[Starting Wireless LAN Communications](#)[Stopping Wireless LAN Communications](#)

---

[▶ Troubleshooting](#)

## How to Use

---

[Parts Description](#)

---

[Setup](#)

---

[Network / Internet](#)

---

[Connections](#)

---

[Settings](#)

---

[View](#)

---

[Playback](#)

---

[Backup / Recovery](#)

---

[Security](#)

---

[Other Operations](#)

---

[Notifications](#)

---

[MONITOR Function](#)

---

## Service and support

### [Keeping Your VAIO Computer in Optimum Condition \(VAIO Care\)](#)

With VAIO Care, you can perform the following operations to keep your VAIO computer running at an optimum level.

### [Using VAIO Update](#)

VAIO Update provides a service that informs you of available update information, such as important notices or update programs, to keep your VAIO computer up to date.

You might be looking for the following topics:

[About Online Support Website](#)[Solving Common Problems with Your VAIO Computer](#)[Updating Your VAIO Computer](#)

---



[▶ Troubleshooting](#)

## How to Use

---

[Parts Description](#)

---

[Setup](#)

---

[Network / Internet](#)

---

[Connections](#)

---

[Settings](#)

---

[View](#)

---

[Playback](#)

---

[Backup / Recovery](#)

---

[Security](#)

---

[Other Operations](#)

---

[Notifications](#)

---

[MONITOR Function](#)

---

## Audio

### [Displaying the Menu Screen \(MONITOR Function\)](#)

With the menu screen, you can customize the settings and switch the input source.

### [Enjoying Sounds Only \(Picture Off\)](#)

This feature lets you enjoy sound only with the LCD screen turned off.

### [Turning Off the LCD Screen](#)

You can turn off the LCD screen and LCD backlight.

You might be looking for the following topics:

[About the MTS Audio Settings \(MONITOR Function\)<TV tuner board installed models>](#)

[About the Scene Select Settings \(MONITOR Function\)](#)

[About the Sound Adjustments / Sound Settings \(MONITOR Function\)](#)

[About the Speakers Settings \(MONITOR Function\)](#)

[Adjusting the Microphone Volume](#)

[Adjusting the Speakers Volume](#)

[Adjusting the Volume in Windows](#)

[Changing the Sound Output Device](#)

[Connecting External Speakers or Headphones](#)

[Connecting a High-Quality Digital Sound Output Device between Your VAIO Computer and a TV](#)

[Connecting an External Microphone](#)

[Using the Settings Menu \(MONITOR Function\)](#)

---

[▶ Troubleshooting](#)

## How to Use

---

[Parts Description](#)

---

[Setup](#)

---

[Network / Internet](#)

---

[Connections](#)

---

[Settings](#)

---

[View](#)

---

[Playback](#)

---

[Backup / Recovery](#)

---

[Security](#)

---

[Other Operations](#)

---

[Notifications](#)

---

[MONITOR Function](#)

---

## CD/DVD/BD

### [Inserting/Removing a Disc<Optical disc drive equipped models>](#)

Insert/remove a disc to/from your VAIO computer that is turned on.

You might be looking for the following topics:

[About Region Codes<Optical disc drive equipped models>](#)

[Booting Your VAIO Computer from External Devices](#)

[Connecting an External DVD Drive](#)

[Handling Discs<Optical disc drive equipped models>](#)

[Notes on Using Discs<Optical disc drive equipped models>](#)

[Supported Discs<Optical disc drive equipped models>](#)

---

[▶ Troubleshooting](#)**How to Use**[Parts Description](#)[Setup](#)[Network / Internet](#)[Connections](#)[Settings](#)[View](#)[Playback](#)[Backup / Recovery](#)[Security](#)[Other Operations](#)[Notifications](#)[MONITOR Function](#)

## Display

### [About the MONITOR Indicator](#)

This topic explains about the conditions of the MONITOR indicator.

### [About the Touch Screen<Touch screen equipped models>](#)

The touch screen enables direct interaction with the VAIO computer using your finger(s). You can perform various gestures on the touch screen to compensate for mouse operations, such as selecting items and scrolling.

### [Adjusting the Angle of the Screen](#)

You can adjust the screen angle of your choice.

### [Displaying Two Pictures on the Screen Simultaneously \(PIP\) <TV tuner board installed models>](#)

This feature lets you watch two pictures on the screen simultaneously.

### [Displaying Two Pictures side-by-side on the Screen \(P&P\)<TV tuner board installed models>](#)

This feature lets you watch two pictures on the screen side-by-side.

### [Displaying the Menu Screen \(MONITOR Function\)](#)

With the menu screen, you can customize the settings and switch the input source.

### [Enjoying Sounds Only \(Picture Off\)](#)

This feature lets you enjoy sound only with the LCD screen turned off.

### [How to Use the Touch Screen<Touch screen equipped models>](#)

You can tap the touch screen or make a simple motion with your fingers to operate the VAIO computer.

### [Multiple Touch Screen Operation](#)

In the VAIO Touch Portal, you can choose a wide variety of software that can be enjoyed with touch screen operation.

### [Notes on Using the Touch Screen<Touch screen equipped models>](#)

Before using the touch screen, read the following precautions for correct use.

### [Turning Off the LCD Screen](#)

You can turn off the LCD screen and LCD backlight.

You might be looking for the following topics:

[About Pro Picture Setup / Video Input Settings \(MONITOR Function\)](#)

[About the Auto Shut-off Settings \(MONITOR Function\)<TV tuner board installed models>](#)

[About the Closed Captions \(CC\) Settings \(MONITOR Function\)<TV tuner board installed models>](#)

[About the Info Banner Settings \(MONITOR Function\)<TV tuner board installed models>](#)

[About the Language Settings \(MONITOR Function\)](#)

[About the Picture Adjustments / Picture Settings \(MONITOR Function\)](#)

[About the Scene Select Settings \(MONITOR Function\)](#)

[About the Screen Settings \(MONITOR Function\)](#)

[Changing the LCD Brightness](#)  
[Changing the Resolution \(Size\) of the Screen Image](#)  
[Changing the Resolution \(Size\) of the Screen Image on an HDMI-Connected Device](#)  
[Connecting a TV with an HDMI Input Port](#)  
[Enable/Disable the Touch Screen<Touch screen equipped models>](#)  
[Enlarging the Text Size \(DPI\)<Touch screen equipped models>](#)  
[Notes on the LCD screen](#)  
[Selecting Display Modes](#)  
[Using the Multiple Monitors Function](#)  
[Using the Settings Menu \(MONITOR Function\)](#)

---

[▶ Troubleshooting](#)

## How to Use

---

[Parts Description](#)

---

[Setup](#)

---

[Network / Internet](#)

---

[Connections](#)

---

[Settings](#)

---

[View](#)

---

[Playback](#)

---

[Backup / Recovery](#)

---

[Security](#)

---

[Other Operations](#)

---

[Notifications](#)

---

[MONITOR Function](#)

---

## Home network

### [About Media Remote](#)

Media Remote allows another device (for example, smartphone, PC) to control an input state other than PC such as HDMI input function via the network.

You might be looking for the following topics:

[About Home Network Setup \(MONITOR Function\)](#)

[Connecting to a Home Network](#)

---

[▶ Troubleshooting](#)**How to Use**[Parts Description](#)[Setup](#)[Network / Internet](#)[Connections](#)[Settings](#)[View](#)[Playback](#)[Backup / Recovery](#)[Security](#)[Other Operations](#)[Notifications](#)[MONITOR Function](#)

## Memory card

### About “Memory Stick”

“Memory Stick” is a compact, portable, and versatile IC recording media especially designed for exchanging and sharing digital data with compatible products, such as digital cameras and other devices. Because it is removable, it can be used for external data storage.

### Compatible “Memory Stick”

The “Memory Stick” slot on your VAIO computer can accommodate the following sizes and types of media:

### Formatting “Memory Stick”

“Memory Stick” is formatted in the specific FAT format by default and is ready for use. Be sure to use the device that is designed to format the media and supports “Memory Stick” when formatting the media.

### Inserting/Removing SD Memory Cards

Your VAIO computer is equipped with an SD memory card slot. You can use this slot to transfer data among digital cameras, camcorders, music players, and other audio/video devices.

### Inserting/Removing “Memory Stick”

You can use “Memory Stick” to save data or transfer images between a digital camera and your VAIO computer. To insert/remove “Memory Stick”, follow these steps.

### Notes on Using SD Memory Cards

Before using SD memory cards, read the following precautions for correct use.

### Notes on Using “Memory Stick”

Before using “Memory Stick”, read the following precautions for correct use.

[▶ Troubleshooting](#)

## How to Use

---

[Parts Description](#)

---

[Setup](#)

---

[Network / Internet](#)

---

[Connections](#)

---

[Settings](#)

---

[View](#)

---

[Playback](#)

---

[Backup / Recovery](#)

---

[Security](#)

---

[Other Operations](#)

---

[Notifications](#)

---

[MONITOR Function](#)

---

## Mouse

### [Replacing the AA Battery of the Mouse](#)

Change the AA battery in the mouse when the battery power becomes low.

You might be looking for the following topics:

[About the Usage Environment for the Mouse](#)[Connecting the Wireless Mouse](#)[Parts and Controls of the Mouse](#)

---

[▶ Troubleshooting](#)**How to Use**[Parts Description](#)[Setup](#)[Network / Internet](#)[Connections](#)[Settings](#)[View](#)[Playback](#)[Backup / Recovery](#)[Security](#)[Other Operations](#)[Notifications](#)[MONITOR Function](#)**Peripheral device**[About Media Remote](#)

Media Remote allows another device (for example, smartphone, PC) to control an input state other than PC such as HDMI input function via the network.

[About “BRAVIA” Sync](#)

With the “BRAVIA” Sync function, you can use the computer’s remote to operate “Control for HDMI”-compatible equipment that is connected to your VAIO computer with an HDMI cable.

[Displaying the Menu Screen \(MONITOR Function\)](#)

With the menu screen, you can customize the settings and switch the input source.

[Enjoying Sounds from Connected Audio System](#)

Change the sound setting on your VAIO computer to output an audio signal to a connected audio system.

[Operating “Control for HDMI”-Compatible Equipment](#)

With the “Control for HDMI” function, you can operate “Control for HDMI”-compatible equipment that is connected to your VAIO computer.

You might be looking for the following topics:

[About HDMI Settings / HDMI Setup \(MONITOR Function\)](#)[About the USB Auto Start Settings \(MONITOR Function\)](#)[Changing the Sound Output Device](#)[Connecting a High-Quality Digital Sound Output Device between Your VAIO Computer and a TV](#)[Connecting a TV with an HDMI Input Port](#)[Connecting a VCR or DVD Player](#)[Connecting an Audio System](#)[Connecting an External Microphone](#)[Connecting to a Home Network](#)[Notes on the LCD screen](#)[Selecting Display Modes](#)[Using the Multiple Monitors Function](#)[Using the Settings Menu \(MONITOR Function\)](#)[Viewing Pictures from Connected Equipment](#)



[▶ Troubleshooting](#)

## How to Use

---

[Parts Description](#)

---

[Setup](#)

---

[Network / Internet](#)

---

[Connections](#)

---

[Settings](#)

---

[View](#)

---

[Playback](#)

---

[Backup / Recovery](#)

---

[Security](#)

---

[Other Operations](#)

---

[Notifications](#)

---

[MONITOR Function](#)

---

## Remote commander

### [Replacing the AA Battery of the Remote Commander<TV tuner board installed models>](#)

If the remote commander does not operate properly, replace the batteries.

You might be looking for the following topics:

[Parts and Controls of the Remote Commander<TV tuner board installed models>](#)

---

[▶ Troubleshooting](#)

## How to Use

---

[Parts Description](#)

---

[Setup](#)

---

[Network / Internet](#)

---

[Connections](#)

---

[Settings](#)

---

[View](#)

---

[Playback](#)

---

[Backup / Recovery](#)

---

[Security](#)

---

[Other Operations](#)

---

[Notifications](#)

---

[MONITOR Function](#)

---

## Touch panel

### [About the Touch Screen<Touch screen equipped models>](#)

The touch screen enables direct interaction with the VAIO computer using your finger(s). You can perform various gestures on the touch screen to compensate for mouse operations, such as selecting items and scrolling.

### [How to Use the Touch Screen<Touch screen equipped models>](#)

You can tap the touch screen or make a simple motion with your fingers to operate the VAIO computer.

### [Multiple Touch Screen Operation](#)

In the VAIO Touch Portal, you can choose a wide variety of software that can be enjoyed with touch screen operation.

### [Notes on Using the Touch Screen<Touch screen equipped models>](#)

Before using the touch screen, read the following precautions for correct use.

You might be looking for the following topics:

[Enable/Disable the Touch Screen<Touch screen equipped models>](#)

[Enlarging the Text Size \(DPI\)<Touch screen equipped models>](#)

---

[▶ Troubleshooting](#)**How to Use**[Parts Description](#)[Setup](#)[Network / Internet](#)[Connections](#)[Settings](#)[View](#)[Playback](#)[Backup / Recovery](#)[Security](#)[Other Operations](#)[Notifications](#)[MONITOR Function](#)**VAIO computer**[About the MONITOR Indicator](#)

This topic explains about the conditions of the MONITOR indicator.

[Adding and Removing Memory Modules](#)

If you want to increase your computer's speed or improve performance when running programs simultaneously, increase the amount of memory by installing optional memory modules.

[Displaying the Menu Screen \(MONITOR Function\)](#)

With the menu screen, you can customize the settings and switch the input source.

[Notes on Adding and Removing Memory Modules](#)

Before adding or removing memory modules, read the following precautions thoroughly.

You might be looking for the following topics:

[About Factory Setting \(MONITOR Function\)](#)[About the ASSIST Button](#)[About the Clock / Timers Settings \(MONITOR Function\)](#)[About the Front Panel Illumination Settings \(MONITOR Function\)](#)[Bootling Your VAIO Computer from External Devices](#)[Checking Supplied Items](#)[Customizing Your VAIO Computer](#)[Keeping Your VAIO Computer in Optimum Condition \(VAIO Care\)](#)[Parts and Controls on the Back](#)[Parts and Controls on the Bottom](#)[Parts and Controls on the Front](#)[Parts and Controls on the Sides](#)[Preparing for Wall Mounting](#)[Setting Up an Appropriate Work Environment](#)[Updating Your VAIO Computer](#)[Using VAIO Update](#)[Using the Settings Menu \(MONITOR Function\)](#)[Viewing the System Information](#)

[▶ Troubleshooting](#)

## How to Use

---

[Parts Description](#)

---

[Setup](#)

---

[Network / Internet](#)

---

[Connections](#)

---

[Settings](#)

---

[View](#)

---

[Playback](#)

---

[Backup / Recovery](#)

---

[Security](#)

---

[Other Operations](#)

---

[Notifications](#)

---

[MONITOR Function](#)

---

## Built-in storage device

### [Creating Other Drives \(Modifying Partitions\)](#)

Partitions are divided areas on your built-in storage device. Dividing the built-in storage device into more than one partition may have various advantages, such as separating the system files from your data files.

### [Creating Partitions during Recovery](#)

This topic describes how to create partitions.

### [Creating Partitions in Windows](#)

The Windows feature allows you to create a partition without recovering your VAIO computer system.

You might be looking for the following topics:

[Checking the Volume of the Recovery Area](#)

[Removing Recovery Contents to Free up Disk Space](#)

---

[▶ Troubleshooting](#)

## How to Use

---

[Parts Description](#)

---

[Setup](#)

---

[Network / Internet](#)

---

[Connections](#)

---

[Settings](#)

---

[View](#)

---

[Playback](#)

---

[Backup / Recovery](#)

---

[Security](#)

---

[Other Operations](#)

---

[Notifications](#)

---

[MONITOR Function](#)

---

## Camera

[Notes on the Built-in Camera<Built-in camera equipped models>](#)[Using the Built-in Camera<Built-in camera equipped models>](#)

If your VAIO computer is equipped with a built-in camera, you can make a video call through the Internet using communication software, such as Windows Live Messenger. For detailed information on how to use the software, refer to the help file included with the software.

---

[▶ Troubleshooting](#)

## How to Use

---

[Parts Description](#)

---

[Setup](#)

---

[Network / Internet](#)

---

[Connections](#)

---

[Settings](#)

---

[View](#)

---

[Playback](#)

---

[Backup / Recovery](#)

---

[Security](#)

---

[Other Operations](#)

---

[Notifications](#)

---

[MONITOR Function](#)

---

## HDMI

### [About "BRAVIA" Sync](#)

With the "BRAVIA" Sync function, you can use the computer's remote to operate "Control for HDMI"-compatible equipment that is connected to your VAIO computer with an HDMI cable.

### [Operating "Control for HDMI"-Compatible Equipment](#)

With the "Control for HDMI" function, you can operate "Control for HDMI"-compatible equipment that is connected to your VAIO computer.

You might be looking for the following topics:

[About HDMI Settings / HDMI Setup \(MONITOR Function\)](#)

[Changing the Resolution \(Size\) of the Screen Image on an HDMI-Connected Device](#)

[Connecting a TV with an HDMI Input Port](#)

[Connecting a VCR or DVD Player](#)

[Connecting an Audio System](#)

---

[▶ Troubleshooting](#)

## How to Use

---

[Parts Description](#)

---

[Setup](#)

---

[Network / Internet](#)

---

[Connections](#)

---

[Settings](#)

---

[View](#)

---

[Playback](#)

---

[Backup / Recovery](#)

---

[Security](#)

---

[Other Operations](#)

---

[Notifications](#)

---

[MONITOR Function](#)

---

## Keyboard

### [Checking the Caps Lock / Num Lock / Scroll Lock States](#)

You can check if the keyboard is in the Caps Lock/Num Lock/Scroll Lock states by the indicator light of the keyboard and the icons in the notification area.

### [Checking the Remaining Battery Power of the Keyboard](#)

The remaining battery power of the keyboard can be checked by the battery indicator.

### [Combinations and Functions with the Fn Key](#)

Press and hold down the Fn key and another key simultaneously to perform a keyboard shortcut action.

### [Replacing the AA Battery of the Keyboard](#)

Change the AA battery in the keyboard when the battery power becomes low.

You might be looking for the following topics:

[About the Usage Environment for the Keyboard](#)

[Changing the Button Assignment \(VAIO Button\)](#)

[Connecting the Wireless Keyboard](#)

[Parts and Controls of the Keyboard](#)

---

[▶ Troubleshooting](#)

## How to Use

---

[Parts Description](#)

---

[Setup](#)

---

[Network / Internet](#)

---

[Connections](#)

---

[Settings](#)

---

[View](#)

---

[Playback](#)

---

[Backup / Recovery](#)

---

[Security](#)

---

[Other Operations](#)

---

[Notifications](#)

---

[MONITOR Function](#)

---

## Memory module

### [Adding and Removing Memory Modules](#)

If you want to increase your computer's speed or improve performance when running programs simultaneously, increase the amount of memory by installing optional memory modules.

### [Notes on Adding and Removing Memory Modules](#)

Before adding or removing memory modules, read the following precautions thoroughly.

You might be looking for the following topics:

[Viewing the System Information](#)

---



[▶ Troubleshooting](#)

## How to Use

---

[Parts Description](#)

---

[Setup](#)

---

[Network / Internet](#)

---

[Connections](#)

---

[Settings](#)

---

[View](#)

---

[Playback](#)

---

[Backup / Recovery](#)

---

[Security](#)

---

[Other Operations](#)

---

[Notifications](#)

---

[MONITOR Function](#)

---

## Partition

### [Creating Other Drives \(Modifying Partitions\)](#)

Partitions are divided areas on your built-in storage device. Dividing the built-in storage device into more than one partition may have various advantages, such as separating the system files from your data files.

### [Creating Partitions during Recovery](#)

This topic describes how to create partitions.

### [Creating Partitions in Windows](#)

The Windows feature allows you to create a partition without recovering your VAIO computer system.

---

[▶ Troubleshooting](#)

## How to Use

---

[Parts Description](#)

---

[Setup](#)

---

[Network / Internet](#)

---

[Connections](#)

---

[Settings](#)

---

[View](#)

---

[Playback](#)

---

[Backup / Recovery](#)

---

[Security](#)

---

[Other Operations](#)

---

[Notifications](#)

---

[MONITOR Function](#)

---

## Power

### [About the MONITOR Indicator](#)

This topic explains about the conditions of the MONITOR indicator.

### [Restarting Your VAIO Computer](#)

After changing the settings or installing software on your VAIO computer, you may be required to restart the computer.

### [Shutting Down Your VAIO Computer](#)

Shut down your VAIO computer properly to avoid losing unsaved data.

### [Turning on Your VAIO Computer](#)

Turn on your VAIO computer to start Windows. Carefully read the precautions in Notes on Using the Power Source before turning on. [Details]

### [Using Sleep Mode](#)

In Sleep mode, all unnecessary devices of your VAIO computer are turned off, though some devices stay on to retain the computer's state including data you are working on. Sleep mode is useful when you take a short rest, for example.

You might be looking for the following topics:

[About the Clock / Timers Settings \(MONITOR Function\)](#)

[Connecting a Power Source](#)

[Notes on Sleep Mode](#)

[Notes on Using the Power Source](#)

[Selecting a Power Plan](#)

---

[▶ Troubleshooting](#)**How to Use**[Parts Description](#)[Setup](#)[Network / Internet](#)[Connections](#)[Settings](#)[View](#)[Playback](#)[Backup / Recovery](#)[Security](#)[Other Operations](#)[Notifications](#)[MONITOR Function](#)**TV****[Quitting TV<TV tuner board installed models>](#)**

Quit showing TV with your VAIO Computer.

You might be looking for the following topics:

[About Add Digital Channels \(MONITOR Function\)<TV tuner board installed models>](#)

[About Antenna Connection<TV tuner board installed models>](#)

[About Auto Program \(MONITOR Function\)<TV tuner board installed models>](#)

[About Edit Channel Labels \(MONITOR Function\)<TV tuner board installed models>](#)

[About Show/Hide Channels \(MONITOR Function\)<TV tuner board installed models>](#)

[About TV Initial Setup \(MONITOR Function\)<TV tuner board installed models>](#)

[About the Analog Fine Tune Settings \(MONITOR Function\)<TV tuner board installed models>](#)

[About the Cable/Antenna Settings \(MONITOR Function\)<TV tuner board installed models>](#)

[About the Closed Captions \(CC\) Settings \(MONITOR Function\)<TV tuner board installed models>](#)

[About the Info Banner Settings \(MONITOR Function\)<TV tuner board installed models>](#)

[About the MTS Audio Settings \(MONITOR Function\)<TV tuner board installed models>](#)

[About the Parental Lock Settings \(MONITOR Function\)<TV tuner board installed models>](#)

[About the Signal Diagnostics Settings \(MONITOR Function\)<TV tuner board installed models>](#)

[Connecting to Standard Cable Access \(CATV\)<TV tuner board installed models>](#)

[Connecting to a Standard Antenna<TV tuner board installed models>](#)

[Running TV Initial Setup<TV tuner board installed models>](#)

[Watching TV with Your VAIO Computer<TV tuner board installed models>](#)

[▶ Troubleshooting](#)

## How to Use

---

[Parts Description](#)

---

[Setup](#)

---

[Network / Internet](#)

---

[Connections](#)

---

[Settings](#)

---

[View](#)

---

[Playback](#)

---

[Backup / Recovery](#)

---

[Security](#)

---

[Other Operations](#)

---

[Notifications](#)

---

[MONITOR Function](#)

---

## USB

### Charging a USB Device

You can charge a USB device even while your VAIO computer is off, in Hibernate mode, or Sleep mode by enabling the USB charging settings.

### Connecting a USB Device

You can connect a Universal Serial Bus (USB) device such as a mouse, floppy disk drive, speaker or printer to your VAIO computer. Installation of the device driver software supplied with the USB device may be required when connecting. Refer to the manual that came with the device for more information.

You might be looking for the following topics:

[About the USB Auto Start Settings \(MONITOR Function\)](#)

---

[▶ Troubleshooting](#)

## How to Use

---

[Parts Description](#)

---

[Setup](#)

---

[Network / Internet](#)

---

[Connections](#)

---

[Settings](#)

---

[View](#)

---

[Playback](#)

---

[Backup / Recovery](#)

---

[Security](#)

---

[Other Operations](#)

---

[Notifications](#)

---

[MONITOR Function](#)

---

## VIDEO input

### [Displaying the Menu Screen \(MONITOR Function\)](#)

With the menu screen, you can customize the settings and switch the input source.

### [Registering Your Favorite Items \(Favorites\)](#)

By registering frequently used and recently viewed items, you can access them quickly from a list.

You might be looking for the following topics:

[Accessing Your Favorite Items](#)

[Using the Settings Menu \(MONITOR Function\)](#)

---

[▶ Troubleshooting](#)

## How to Use

---

[Parts Description](#)

---

[Setup](#)

---

[Network / Internet](#)

---

[Connections](#)

---

[Settings](#)

---

[View](#)

---

[Playback](#)

---

[Backup / Recovery](#)

---

[Security](#)

---

[Other Operations](#)

---

[Notifications](#)

---

[MONITOR Function](#)

---

## CD/DVD/BD

### [About Region Codes<Optical disc drive equipped models>](#)

The following is a list of DVD region codes indicating playable regions of DVD media.

### [Handling Discs<Optical disc drive equipped models>](#)

Read the following to protect data stored on discs and take proper care of discs.

### [Notes on Using Discs<Optical disc drive equipped models>](#)

Observe the following notes when using discs on your VAIO computer.

### [Supported Discs<Optical disc drive equipped models>](#)

This topic explains media types that are playable/recordable on your VAIO computer.

You might be looking for the following topics:

[Booting Your VAIO Computer from External Devices](#)

[Connecting an External DVD Drive](#)

[Inserting/Removing a Disc<Optical disc drive equipped models>](#)

---

[▶ Troubleshooting](#)

## How to Use

---

[Parts Description](#)

---

[Setup](#)

---

[Network / Internet](#)

---

[Connections](#)

---

[Settings](#)

---

[View](#)

---

[Playback](#)

---

[Backup / Recovery](#)

---

[Security](#)

---

[Other Operations](#)

---

[Notifications](#)

---

[MONITOR Function](#)

---

## Important notice

### [About the International ENERGY STAR\(R\) Program](#)

The following information is applicable to ENERGY STAR qualified products only.

### [About the Software License](#)

This product contains software owned by Sony and licensed by third parties. Use of such software is subject to the terms and conditions of license agreements enclosed with this product.

### [Handling the Built-in Storage Device](#)

The built-in storage device (hard disk drive or solid state drive) has a high storage density and reads or writes data in a short time. However, it can be easily damaged if improperly used.

### [Safety Information](#)

Refer to the supplied safety manual for detailed safety information.

### [Trademarks](#)

---

[▶ Troubleshooting](#)

**How to Use**

---

Parts Description

---

Setup

---

Network / Internet

---

Connections

---

Settings

---

View

---

Playback

---

Backup / Recovery

---

Security

---

Other Operations

---

Notifications

---

MONITOR Function

---

**Read this first**

[Read This First](#)

Congratulations on your purchase of this VAIO(R) computer and welcome to the on-screen User Guide.

---



[▶ Troubleshooting](#)

## How to Use

---

[Parts Description](#)

---

[Setup](#)

---

[Network / Internet](#)

---

[Connections](#)

---

[Settings](#)

---

[View](#)

---

[Playback](#)

---

[Backup / Recovery](#)

---

[Security](#)

---

[Other Operations](#)

---

[Notifications](#)

---

[MONITOR Function](#)

---

## Service and support

### [About Online Support Website](#)

The online support website provides information about frequently asked questions about your VAIO computer.

### [Solving Common Problems with Your VAIO Computer](#)

If you have any problem operating your VAIO computer, try these suggestions before contacting an authorized Sony service/support center or your local Sony dealer directly.

### [Updating Your VAIO Computer](#)

Be sure to update your VAIO computer with the following software applications to enhance the computer's efficiency, security, and functionality.

You might be looking for the following topics:

[Keeping Your VAIO Computer in Optimum Condition \(VAIO Care\)](#)

[Using VAIO Update](#)

---

[▶ Troubleshooting](#)**How to Use**[Parts Description](#)[Setup](#)[Network / Internet](#)[Connections](#)[Settings](#)[View](#)[Playback](#)[Backup / Recovery](#)[Security](#)[Other Operations](#)[Notifications](#)[MONITOR Function](#)**VAIO computer**[Checking Supplied Items](#)

Check all items packed with the product before use.

[Setting Up an Appropriate Work Environment](#)

This topic describes where to or not to place your VAIO computer and ergonomic instructions.

[Updating Your VAIO Computer](#)

Be sure to update your VAIO computer with the following software applications to enhance the computer's efficiency, security, and functionality.

You might be looking for the following topics:

[About Factory Setting \(MONITOR Function\)](#)[About the ASSIST Button](#)[About the Clock / Timers Settings \(MONITOR Function\)](#)[About the Front Panel Illumination Settings \(MONITOR Function\)](#)[About the MONITOR Indicator](#)[Adding and Removing Memory Modules](#)[Booting Your VAIO Computer from External Devices](#)[Customizing Your VAIO Computer](#)[Displaying the Menu Screen \(MONITOR Function\)](#)[Keeping Your VAIO Computer in Optimum Condition \(VAIO Care\)](#)[Notes on Adding and Removing Memory Modules](#)[Parts and Controls on the Back](#)[Parts and Controls on the Bottom](#)[Parts and Controls on the Front](#)[Parts and Controls on the Sides](#)[Preparing for Wall Mounting](#)[Using VAIO Update](#)[Using the Settings Menu \(MONITOR Function\)](#)[Viewing the System Information](#)

[▶ Troubleshooting](#)

## How to Use

---

[Parts Description](#)

---

[Setup](#)

---

[Network / Internet](#)

---

[Connections](#)

---

[Settings](#)

---

[View](#)

---

[Playback](#)

---

[Backup / Recovery](#)

---

[Security](#)

---

[Other Operations](#)

---

[Notifications](#)

---

[MONITOR Function](#)

---

## Care and maintenance

### [Cleaning Your VAIO computer/LCD screen](#)

Before cleaning your VAIO computer, read the following precautions for the correct cleaning procedure.

---

[▶ Troubleshooting](#)

## How to Use

---

[Parts Description](#)

---

[Setup](#)

---

[Network / Internet](#)

---

[Connections](#)

---

[Settings](#)

---

[View](#)

---

[Playback](#)

---

[Backup / Recovery](#)

---

[Security](#)

---

[Other Operations](#)

---

[Notifications](#)

---

[MONITOR Function](#)

---

## Product registration

### [About Online Support Website](#)

The online support website provides information about frequently asked questions about your VAIO computer.

---

[▶ Troubleshooting](#)

## How to Use

---

[Parts Description](#)

---

[Setup](#)

---

[Network / Internet](#)

---

[Connections](#)

---

[Settings](#)

---

[View](#)

---

[Playback](#)

---

[Backup / Recovery](#)

---

[Security](#)

---

[Other Operations](#)

---

[Notifications](#)

---

[MONITOR Function](#)

---

## Security

### Updating Your VAIO Computer

Be sure to update your VAIO computer with the following software applications to enhance the computer's efficiency, security, and functionality.

---

[▶ Troubleshooting](#)

## How to Use

---

[Parts Description](#)

---

[Setup](#)

---

[Network / Internet](#)

---

[Connections](#)

---

[Settings](#)

---

[View](#)

---

[Playback](#)

---

[Backup / Recovery](#)

---

[Security](#)

---

[Other Operations](#)

---

[Notifications](#)

---

[MONITOR Function](#)

---

## Supplied items

### Checking Supplied Items

Check all items packed with the product before use.

---

[▶ Troubleshooting](#)

## How to Use

---

[Parts Description](#)

---

[Setup](#)

---

[Network / Internet](#)

---

[Connections](#)

---

[Settings](#)

---

[View](#)

---

[Playback](#)

---

[Backup / Recovery](#)

---

[Security](#)

---

[Other Operations](#)

---

[Notifications](#)

---

[MONITOR Function](#)

## Antenna

### [About the Cable/Antenna Settings \(MONITOR Function\)<TV tuner board installed models>](#)

Sets the received signal to Cable or Antenna.

You might be looking for the following topics:

[About Antenna Connection<TV tuner board installed models>](#)

[Connecting to Standard Cable Access \(CATV\)<TV tuner board installed models>](#)

[Connecting to a Standard Antenna<TV tuner board installed models>](#)

---

[▶ Troubleshooting](#)**How to Use**[Parts Description](#)[Setup](#)[Network / Internet](#)[Connections](#)[Settings](#)[View](#)[Playback](#)[Backup / Recovery](#)[Security](#)[Other Operations](#)[Notifications](#)**[MONITOR Function](#)**

## Display

[About Pro Picture Setup / Video Input Settings \(MONITOR Function\)](#)

This topic explains the advanced- picture settings.

[About the Auto Shut-off Settings \(MONITOR Function\)<TV tuner board installed models>](#)

Turns the TV off when no input signal is detected for 15 minutes.

[About the Closed Captions \(CC\) Settings \(MONITOR Function\)<TV tuner board installed models>](#)

This setting allows you to select from several closed caption modes.

[About the Info Banner Settings \(MONITOR Function\)<TV tuner board installed models>](#)

Sets the amount of information to display about the currently viewed TV channel and program.

[About the Language Settings \(MONITOR Function\)](#)

Sets the language displayed on the menu screens.

[About the MONITOR Indicator](#)

This topic explains about the conditions of the MONITOR indicator.

[About the Picture Adjustments / Picture Settings \(MONITOR Function\)](#)

This topic explains picture adjustments (for input sources other than PC).

[About the Scene Select Settings \(MONITOR Function\)](#)

This setting allows you to optimize picture and sound quality according to the input source.

[About the Screen Settings \(MONITOR Function\)](#)

This topic explains screen settings.

[Displaying Two Pictures on the Screen Simultaneously \(PIP\) <TV tuner board installed models>](#)

This feature lets you watch two pictures on the screen simultaneously.

[Displaying Two Pictures side-by-side on the Screen \(P&P\)<TV tuner board installed models>](#)

This feature lets you watch two pictures on the screen side-by-side.

[Displaying the Menu Screen \(MONITOR Function\)](#)

With the menu screen, you can customize the settings and switch the input source.

[Enjoying Sounds Only \(Picture Off\)](#)

This feature lets you enjoy sound only with the LCD screen turned off.

[Using the Settings Menu \(MONITOR Function\)](#)

With the settings menu, you can customize the settings such as the display and sound settings.

You might be looking for the following topics:



[About the Touch Screen<Touch screen equipped models>](#)  
[Adjusting the Angle of the Screen](#)  
[Changing the LCD Brightness](#)  
[Changing the Resolution \(Size\) of the Screen Image](#)  
[Changing the Resolution \(Size\) of the Screen Image on an HDMI-Connected Device](#)  
[Connecting a TV with an HDMI Input Port](#)  
[Enable/Disable the Touch Screen<Touch screen equipped models>](#)  
[Enlarging the Text Size \(DPI\)<Touch screen equipped models>](#)  
[How to Use the Touch Screen<Touch screen equipped models>](#)  
[Multiple Touch Screen Operation](#)  
[Notes on Using the Touch Screen<Touch screen equipped models>](#)  
[Notes on the LCD screen](#)  
[Selecting Display Modes](#)  
[Turning Off the LCD Screen](#)  
[Using the Multiple Monitors Function](#)

---

[▶ Troubleshooting](#)

## How to Use

---

[Parts Description](#)

---

[Setup](#)

---

[Network / Internet](#)

---

[Connections](#)

---

[Settings](#)

---

[View](#)

---

[Playback](#)

---

[Backup / Recovery](#)

---

[Security](#)

---

[Other Operations](#)

---

[Notifications](#)

---

[MONITOR Function](#)

## Home network

### [About Home Network Setup \(MONITOR Function\)](#)

This topic explains the home network setting.

### [About Media Remote](#)

Media Remote allows another device (for example, smartphone, PC) to control an input state other than PC such as HDMI input function via the network.

### [Connecting to a Home Network](#)

You can enjoy various content (for example, photo/music/video files) stored on DLNA-certified media servers. The home network feature allows you to enjoy network content in other rooms.

---

[▶ Troubleshooting](#)

## How to Use

---

[Parts Description](#)

---

[Setup](#)

---

[Network / Internet](#)

---

[Connections](#)

---

[Settings](#)

---

[View](#)

---

[Playback](#)

---

[Backup / Recovery](#)

---

[Security](#)

---

[Other Operations](#)

---

[Notifications](#)

---

[MONITOR Function](#)

## Music

### [Notes on Playing Photos / Music / Videos without Starting Windows](#)

These notes explain how to play contents stored in connected USB device without starting Windows, and playable data formats.

### [Playing Photos / Music / Videos Stored in the Connecting USB Device without Starting Windows](#)

Plays photos/music/videos on the screen by connecting a Sony digital still camera or other USB-compatible device.

---

[▶ Troubleshooting](#)

## How to Use

---

[Parts Description](#)

---

[Setup](#)

---

[Network / Internet](#)

---

[Connections](#)

---

[Settings](#)

---

[View](#)

---

[Playback](#)

---

[Backup / Recovery](#)

---

[Security](#)

---

[Other Operations](#)

---

[Notifications](#)

---

[MONITOR Function](#)

## Photo

### [Notes on Playing Photos / Music / Videos without Starting Windows](#)

These notes explain how to play contents stored in connected USB device without starting Windows, and playable data formats.

### [Playing Photos / Music / Videos Stored in the Connecting USB Device without Starting Windows](#)

Plays photos/music/videos on the screen by connecting a Sony digital still camera or other USB-compatible device.

---

[▶ Troubleshooting](#)

**How to Use**

---

Parts Description

---

Setup

---

Network / Internet

---

Connections

---

Settings

---

View

---

Playback

---

Backup / Recovery

---

Security

---

Other Operations

---

Notifications

---

**MONITOR Function**

**Software**

[About Monitor Software version \(MONITOR Function\)](#)

---

[▶ Troubleshooting](#)**How to Use**[Parts Description](#)[Setup](#)[Network / Internet](#)[Connections](#)[Settings](#)[View](#)[Playback](#)[Backup / Recovery](#)[Security](#)[Other Operations](#)[Notifications](#)**MONITOR Function****TV**[About Add Digital Channels \(MONITOR Function\)<TV tuner board installed models>](#)

Adds digital channels.

[About Auto Program \(MONITOR Function\)<TV tuner board installed models>](#)

Automatically scans for all available channels and stores them in the TV.

[About Edit Channel Labels \(MONITOR Function\)<TV tuner board installed models>](#)

Edit channel labels to your preference.

[About Show/Hide Channels \(MONITOR Function\)<TV tuner board installed models>](#)

Shows or hides channels when you surf with CH +/- or in the TV channel list.

[About TV Initial Setup \(MONITOR Function\)<TV tuner board installed models>](#)

Runs the initial setup that appeared when you first connected the TV.

[About the Analog Fine Tune Settings \(MONITOR Function\)<TV tuner board installed models>](#)

Allows you to fine-tune analog channels to adjust picture quality.

[About the Cable/Antenna Settings \(MONITOR Function\)<TV tuner board installed models>](#)

Sets the received signal to Cable or Antenna.

[About the Closed Captions \(CC\) Settings \(MONITOR Function\)<TV tuner board installed models>](#)

This setting allows you to select from several closed caption modes.

[About the Info Banner Settings \(MONITOR Function\)<TV tuner board installed models>](#)

Sets the amount of information to display about the currently viewed TV channel and program.

[About the MTS Audio Settings \(MONITOR Function\)<TV tuner board installed models>](#)

Sets audio settings for analog programs.

[About the Parental Lock Settings \(MONITOR Function\)<TV tuner board installed models>](#)

Sets an age restriction for viewing, or blocks specific channels.

[About the Signal Diagnostics Settings \(MONITOR Function\)<TV tuner board installed models>](#)

Displays the diagnostics information for the current signal.

[Quitting TV<TV tuner board installed models>](#)

Quit showing TV with your VAIO Computer.

[Running TV Initial Setup<TV tuner board installed models>](#)

To watch TV with your VAIO computer, you must first run TV Initial Setup.

[Watching TV with Your VAIO Computer<TV tuner board installed models>](#)

You can begin watching TV programs quickly without starting Windows.

You might be looking for the following topics:

[About Antenna Connection<TV tuner board installed models>](#)

[Connecting to Standard Cable Access \(CATV\)<TV tuner board installed models>](#)

[Connecting to a Standard Antenna<TV tuner board installed models>](#)

---

[▶ Troubleshooting](#)

## How to Use

[Parts Description](#)[Setup](#)[Network / Internet](#)[Connections](#)[Settings](#)[View](#)[Playback](#)[Backup / Recovery](#)[Security](#)[Other Operations](#)[Notifications](#)[MONITOR Function](#)

## VAIO computer

[About Factory Setting \(MONITOR Function\)](#)

Returns the current settings to the initial settings.

[About the Clock / Timers Settings \(MONITOR Function\)](#)

This topic explains clock or timers settings.

[About the Front Panel Illumination Settings \(MONITOR Function\)](#)

Turns the logo lamp on the front of your VAIO computer on or off.

[About the MONITOR Indicator](#)

This topic explains about the conditions of the MONITOR indicator.

[Displaying the Menu Screen \(MONITOR Function\)](#)

With the menu screen, you can customize the settings and switch the input source.

[Using the Settings Menu \(MONITOR Function\)](#)

With the settings menu, you can customize the settings such as the display and sound settings.

You might be looking for the following topics:

[About the ASSIST Button](#)[Adding and Removing Memory Modules](#)[Booting Your VAIO Computer from External Devices](#)[Checking Supplied Items](#)[Customizing Your VAIO Computer](#)[Keeping Your VAIO Computer in Optimum Condition \(VAIO Care\)](#)[Notes on Adding and Removing Memory Modules](#)[Parts and Controls on the Back](#)[Parts and Controls on the Bottom](#)[Parts and Controls on the Front](#)[Parts and Controls on the Sides](#)[Preparing for Wall Mounting](#)[Setting Up an Appropriate Work Environment](#)[Updating Your VAIO Computer](#)[Using VAIO Update](#)[Viewing the System Information](#)



[▶ Troubleshooting](#)

## How to Use

---

[Parts Description](#)

---

[Setup](#)

---

[Network / Internet](#)

---

[Connections](#)

---

[Settings](#)

---

[View](#)

---

[Playback](#)

---

[Backup / Recovery](#)

---

[Security](#)

---

[Other Operations](#)

---

[Notifications](#)

---

[MONITOR Function](#)

## Video

### [Notes on Playing Photos / Music / Videos without Starting Windows](#)

These notes explain how to play contents stored in connected USB device without starting Windows, and playable data formats.

### [Playing Photos / Music / Videos Stored in the Connecting USB Device without Starting Windows](#)

Plays photos/music/videos on the screen by connecting a Sony digital still camera or other USB-compatible device.

---

[▶ Troubleshooting](#)**How to Use**[Parts Description](#)[Setup](#)[Network / Internet](#)[Connections](#)[Settings](#)[View](#)[Playback](#)[Backup / Recovery](#)[Security](#)[Other Operations](#)[Notifications](#)[MONITOR Function](#)**Audio**[About the MTS Audio Settings \(MONITOR Function\)<TV tuner board installed models>](#)

Sets audio settings for analog programs.

[About the Scene Select Settings \(MONITOR Function\)](#)

This setting allows you to optimize picture and sound quality according to the input source.

[About the Sound Adjustments / Sound Settings \(MONITOR Function\)](#)

This topic explains sound adjustments.

[About the Speakers Settings \(MONITOR Function\)](#)

Sets the sound output.

[Displaying the Menu Screen \(MONITOR Function\)](#)

With the menu screen, you can customize the settings and switch the input source.

[Enjoying Sounds Only \(Picture Off\)](#)

This feature lets you enjoy sound only with the LCD screen turned off.

[Using the Settings Menu \(MONITOR Function\)](#)

With the settings menu, you can customize the settings such as the display and sound settings.

You might be looking for the following topics:

[Adjusting the Microphone Volume](#)[Adjusting the Speakers Volume](#)[Adjusting the Volume in Windows](#)[Changing the Sound Output Device](#)[Connecting External Speakers or Headphones](#)[Connecting a High-Quality Digital Sound Output Device between Your VAIO Computer and a TV](#)[Connecting an External Microphone](#)[Turning Off the LCD Screen](#)

[▶ Troubleshooting](#)

## How to Use

[Parts Description](#)[Setup](#)[Network / Internet](#)[Connections](#)[Settings](#)[View](#)[Playback](#)[Backup / Recovery](#)[Security](#)[Other Operations](#)[Notifications](#)[MONITOR Function](#)

## HDMI

### [About HDMI Settings / HDMI Setup \(MONITOR Function\)](#)

This topic explains the settings for the “Control for HDMI” function.

### [About “BRAVIA” Sync](#)

With the “BRAVIA” Sync function, you can use the computer’s remote to operate “Control for HDMI”-compatible equipment that is connected to your VAIO computer with an HDMI cable.

### [Connecting a VCR or DVD Player](#)

By connecting a VCR or DVD player to your VAIO computer, you can enjoy pictures on the computer screen.

### [Connecting an Audio System](#)

Connect an audio system such as an AV amplifier or a home theater system to your VAIO computer.

### [Operating “Control for HDMI”-Compatible Equipment](#)

With the “Control for HDMI” function, you can operate “Control for HDMI”-compatible equipment that is connected to your VAIO computer.

You might be looking for the following topics:

[Changing the Resolution \(Size\) of the Screen Image on an HDMI-Connected Device](#)

[Connecting a TV with an HDMI Input Port](#)

[▶ Troubleshooting](#)

## How to Use

---

[Parts Description](#)

---

[Setup](#)

---

[Network / Internet](#)

---

[Connections](#)

---

[Settings](#)

---

[View](#)

---

[Playback](#)

---

[Backup / Recovery](#)

---

[Security](#)

---

[Other Operations](#)

---

[Notifications](#)

---

[MONITOR Function](#)

## Internet

### [About Network Setup \(MONITOR Function\)](#)

This topic explains the network setting of the MONITOR ONLY LAN port.

You might be looking for the following topics:

[About a Security Key for a Wireless LAN](#)[About the Internet Connection Services](#)[About the Network \(LAN\)](#)[About the Wireless LAN Standards](#)[Before Using the Wireless LAN](#)[Connecting to the Internet with a Wired Connection](#)[Launching the Web Browser \(WEB Button\)](#)[Notes on Using the Wireless LAN Function](#)[Starting Wireless LAN Communications](#)[Stopping Wireless LAN Communications](#)[Using the Antivirus Software for Your VAIO Computer](#)

[▶ Troubleshooting](#)**How to Use**[Parts Description](#)[Setup](#)[Network / Internet](#)[Connections](#)[Settings](#)[View](#)[Playback](#)[Backup / Recovery](#)[Security](#)[Other Operations](#)[Notifications](#)**MONITOR Function**

## Peripheral device

### [About HDMI Settings / HDMI Setup \(MONITOR Function\)](#)

This topic explains the settings for the “Control for HDMI” function.

### [About Media Remote](#)

Media Remote allows another device (for example, smartphone, PC) to control an input state other than PC such as HDMI input function via the network.

### [About the USB Auto Start Settings \(MONITOR Function\)](#)

Starts a slideshow automatically using photos stored in a connected USB device, such as a digital camera.

### [About “BRAVIA” Sync](#)

With the “BRAVIA” Sync function, you can use the computer’s remote to operate “Control for HDMI”-compatible equipment that is connected to your VAIO computer with an HDMI cable.

### [Connecting a VCR or DVD Player](#)

By connecting a VCR or DVD player to your VAIO computer, you can enjoy pictures on the computer screen.

### [Connecting an Audio System](#)

Connect an audio system such as an AV amplifier or a home theater system to your VAIO computer.

### [Connecting to a Home Network](#)

You can enjoy various content (for example, photo/music/video files) stored on DLNA-certified media servers. The home network feature allows you to enjoy network content in other rooms.

### [Displaying the Menu Screen \(MONITOR Function\)](#)

With the menu screen, you can customize the settings and switch the input source.

### [Enjoying Sounds from Connected Audio System](#)

Change the sound setting on your VAIO computer to output an audio signal to a connected audio system.

### [Operating “Control for HDMI”-Compatible Equipment](#)

With the “Control for HDMI” function, you can operate “Control for HDMI”-compatible equipment that is connected to your VAIO computer.

### [Using the Settings Menu \(MONITOR Function\)](#)

With the settings menu, you can customize the settings such as the display and sound settings.

### [Viewing Pictures from Connected Equipment](#)

Switch the input selector of your VAIO computer so that the signal from a connected VCR or DVD player appears on the computer screen.

You might be looking for the following topics:

[Changing the Sound Output Device](#)

[Connecting a High-Quality Digital Sound Output Device between Your VAIO Computer and a](#)

## TV

Connecting a TV with an HDMI Input Port

Connecting an External Microphone

Notes on the LCD screen

Selecting Display Modes

Using the Multiple Monitors Function

---

[▶ Troubleshooting](#)

## How to Use

---

[Parts Description](#)

---

[Setup](#)

---

[Network / Internet](#)

---

[Connections](#)

---

[Settings](#)

---

[View](#)

---

[Playback](#)

---

[Backup / Recovery](#)

---

[Security](#)

---

[Other Operations](#)

---

[Notifications](#)

---

[MONITOR Function](#)

## Power

### [About the Clock / Timers Settings \(MONITOR Function\)](#)

This topic explains clock or timers settings.

### [About the MONITOR Indicator](#)

This topic explains about the conditions of the MONITOR indicator.

You might be looking for the following topics:

[Connecting a Power Source](#)[Notes on Sleep Mode](#)[Notes on Using the Power Source](#)[Restarting Your VAIO Computer](#)[Selecting a Power Plan](#)[Shutting Down Your VAIO Computer](#)[Turning on Your VAIO Computer](#)[Using Sleep Mode](#)

---

[▶ Troubleshooting](#)

## How to Use

---

[Parts Description](#)

---

[Setup](#)

---

[Network / Internet](#)

---

[Connections](#)

---

[Settings](#)

---

[View](#)

---

[Playback](#)

---

[Backup / Recovery](#)

---

[Security](#)

---

[Other Operations](#)

---

[Notifications](#)

---

[MONITOR Function](#)

## Speakers

### [About the Speakers Settings \(MONITOR Function\)](#)

Sets the sound output.

You might be looking for the following topics:

[Adjusting the Speakers Volume](#)[Connecting External Speakers or Headphones](#)

---



[▶ Troubleshooting](#)

## How to Use

---

[Parts Description](#)

---

[Setup](#)

---

[Network / Internet](#)

---

[Connections](#)

---

[Settings](#)

---

[View](#)

---

[Playback](#)

---

[Backup / Recovery](#)

---

[Security](#)

---

[Other Operations](#)

---

[Notifications](#)

---

[MONITOR Function](#)

## USB

### [About the USB Auto Start Settings \(MONITOR Function\)](#)

Starts a slideshow automatically using photos stored in a connected USB device, such as a digital camera.

You might be looking for the following topics:

[Charging a USB Device](#)[Connecting a USB Device](#)

---

[▶ Troubleshooting](#)

## How to Use

---

[Parts Description](#)

---

[Setup](#)

---

[Network / Internet](#)

---

[Connections](#)

---

[Settings](#)

---

[View](#)

---

[Playback](#)

---

[Backup / Recovery](#)

---

[Security](#)

---

[Other Operations](#)

---

[Notifications](#)

---

[MONITOR Function](#)

## VIDEO input

### [Accessing Your Favorite Items](#)

Access your favorite items registered on a list.

### [Displaying the Menu Screen \(MONITOR Function\)](#)

With the menu screen, you can customize the settings and switch the input source.

### [Registering Your Favorite Items \(Favorites\)](#)

By registering frequently used and recently viewed items, you can access them quickly from a list.

### [Using the Settings Menu \(MONITOR Function\)](#)

With the settings menu, you can customize the settings such as the display and sound settings.

---



[> How to Use](#)

**Troubleshooting**

Hardware

Software

Network / Internet

Backup / Recovery

Security

Peripheral Devices

Others

**Hardware**

Audio

BLUETOOTH

Camera

Display

HDMI

LAN

Microphone

Password

Software

Wireless LAN

BIOS

CD/DVD/BD

Computer

Floppy disk

Keyboard

Memory card

Mouse

Power

USB

[▶ How to Use](#)

**Troubleshooting**

---

Hardware

**Software**

Network / Internet

---

Backup / Recovery

---

Security

---

Peripheral Devices

---

Others

---

**Software**

[Display](#)

[Software](#)

---

[▶ How to Use](#)

**Troubleshooting**

---

Hardware

---

Software

**Network / Internet**

Backup / Recovery

---

Security

---

Peripheral Devices

---

Others

---

**Network / Internet**

[BLUETOOTH](#)

[LAN](#)

[Wireless LAN](#)

---

[▶ How to Use](#)

**Troubleshooting**

---

Hardware

---

Software

---

Network / Internet

**Backup / Recovery**

Security

---

Peripheral Devices

---

Others

---

## Backup / Recovery

[Floppy disk](#)

[Recovery](#)

[USB](#)

---

[▶ How to Use](#)

**Troubleshooting**

---

Hardware

---

Software

---

Network / Internet

---

Backup / Recovery

---

**Security**

---

Peripheral Devices

---

Others

---

## Security

[BIOS](#)

[Password](#)

---



[▶ How to Use](#)

**Troubleshooting**

---

Hardware

---

Software

---

Network / Internet

---

Backup / Recovery

---

Security

Peripheral Devices

Others

---

## Peripheral Devices

[Floppy disk](#)

[Peripheral device](#)

[USB](#)

[HDMI](#)

[Printer](#)

[i.LINK](#)

---



[▶ How to Use](#)

**Troubleshooting**

---

Hardware

---

Software

---

Network / Internet

---

Backup / Recovery

---

Security

---

Peripheral Devices

---

Others

**Others**

[TV](#)

---

[▶ Troubleshooting](#)**How to Use**[Parts Description](#)[Setup](#)[Network / Internet](#)[Connections](#)[Settings](#)[View](#)[Playback](#)[Backup / Recovery](#)[Security](#)[Other Operations](#)[Notifications](#)[MONITOR Function](#)

## About Online Support Website

The online support website provides information about frequently asked questions about your VAIO computer.

Sony online support website

- USA  
<http://esupport.sony.com/EN/VAIO/>
- Canada  
<http://www.sony.ca/support/> (English)  
<http://fr.sony.ca/support/> (French)
- Spanish-speaking Latin American countries or areas  
<http://esupport.sony.com/ES/VAIO/LA/>
- Brazil  
<http://esupport.sony.com/PT/VAIO/BR/>

Hint

- If you experience any problem and have a technical question about your VAIO computer, launch VAIO Care first, which offers you various options to help you solve the problem.[\[Details\]](#)
- When you contact VAIO support, you may be asked for the serial number and the model number of your VAIO computer. The serial number is a 15-digit number that can be found:
  - in the VAIO Care window;
  - on the bottom, the back panel of the computer, inside the back panel or inside the battery compartment;
  - on the original VAIO box.

The model number is located at the lower right corner of the display on the VAIO computer.

### Other websites

You can find other useful information from the following URL.

Sony products

<http://www.sony.net/>  
<http://www.sony.net/electronics/>

Operating system online support website

For Microsoft Windows operating system support, visit the Microsoft customer support site.  
<http://support.microsoft.com/>

In Store Service & Support (available in USA only)

Make an appointment with a Sony certified technician at a U.S. Sony Store and get personalized service and support for your VAIO computer. Sony Technicians can assist with the setup of your new VAIO computer, system optimization, data rescue, and any repair service you might need.

<http://www.sony.com/store/>

Hint

- You can find a link to register your computer online in VAIO Care. Click  (Start), All Programs, and VAIO Care.

---

Related Topic

[Read This First](#)

[Keeping Your VAIO Computer in Optimum Condition \(VAIO Care\)](#)

---

[▶ Troubleshooting](#)**How to Use**[Parts Description](#)[Setup](#)[Network / Internet](#)[Connections](#)[Settings](#)[View](#)[Playback](#)[Backup / Recovery](#)[Security](#)[Other Operations](#)[Notifications](#)[MONITOR Function](#)

## Welcome

Congratulations on the purchase of this VAIO(R) computer.

This User Guide - Introduction Version provides you with limited information about your VAIO computer. To update this file to the complete version of the User Guide, see [Updating the User Guide to the Latest Version \[Details\]](#) for more information.

[Updating the User Guide to the Latest Version](#)[Connecting to the Internet](#)[Updating Your VAIO Computer](#)[Solving Problems on Your VAIO Computer Using VAIO Care](#)[Finding Support Information](#)[Trademarks](#)[^ Go to top](#)

## Updating the User Guide to the Latest Version

By updating this User Guide - Introduction Version through the Internet, you can get the complete version of the User Guide with detailed information on your VAIO computer. Once the User Guide is updated to the complete version, you can access it anytime even if you are offline.

With the complete version of the User Guide, you can view information about:

- Parts description
- Feature and operating instructions
- Precautions
- Troubleshooting information

Below is an example of a screenshot in English.



\* Design and content of the screen are subject to change.

To get the complete version of the User Guide

1. Connect your VAIO computer to the Internet. [\[Details\]](#)
2. Close this window, and then click  (Start), All Programs, and VAIO Manual again.

3. A window prompting you to update the manual appears. Follow the on-screen instructions.  
This file will automatically update to the complete version of the User Guide.  
If the window prompting you to update the User Guide does not appear, make sure your VAIO computer is connected to the Internet and repeat the above steps.  
If the update window still does not appear, launch VAIO Update so you can find and download the User Guide manually. See [Updating Your VAIO Computer \[Details\]](#) for more information on VAIO Update.

Hint

- It may take some time to complete the update.

To view help files for Windows OS and software operations

When you have trouble operating your VAIO computer, try referring to Windows Help and Support or help files included with your applications.

To access Windows Help and Support, click  (Start) and Help and Support.

[^ Go to top](#)

## Connecting to the Internet

You will need to connect your VAIO computer to the Internet before updating to the complete version of the User Guide.

### Before connecting to the Internet

Before using the Internet, you will need to sign up with an Internet Service Provider (ISP) and set up devices required for connecting your VAIO computer to the Internet.

The following types of Internet connection services may be available from your ISP:

- Fiber to the Home (FTTH)
- Digital Subscriber Line (DSL)
- Cable modem
- Satellite
- Dial-up

For more information on devices required for Internet access and how to connect your VAIO computer to the Internet, ask your ISP.

The following is one of the Internet connection methods as an example.

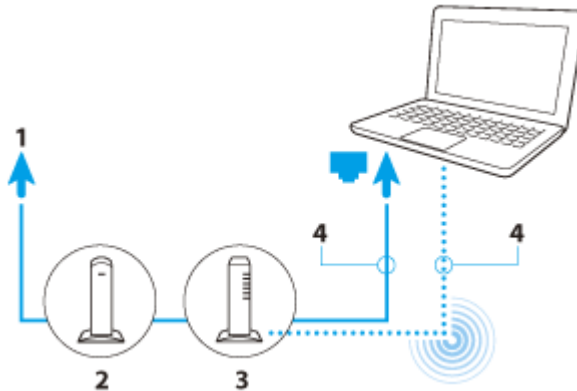

1. Internet
2. Modem
3. Router/access point
4. LAN cable (not supplied) or wireless LAN

## To use the network (LAN)

You can connect your VAIO computer to networks with a LAN cable. Connect one end of a LAN cable to the LAN port on the computer and the other end to your network. For detailed settings and devices required for LAN access, ask your network administrator.

### Note

- The connection, setting method, or required devices may vary depending on your network environment.

## To use the wireless LAN network (Wi-Fi)

You first need to establish wireless LAN communications between your VAIO computer and an access point (not supplied). Refer to Windows Help and Support for more information.

## To start wireless LAN communications with VAIO Easy Connect

You can easily set up wireless LAN communications by following the instructions in VAIO Easy Connect. VAIO Easy Connect supports you especially when you first set up a wireless Internet connection at home or when you connect to a public wireless network (Wi-Fi hotspot).

1. Click  (Start), All Programs, VAIO Easy Connect, and Easy Internet Connection Setup.
2. Follow the on-screen instructions to setup wireless LAN communications.

[^ Go to top](#)

---

## Updating Your VAIO Computer

Be sure to update your VAIO computer with the following software applications to enhance the computer's efficiency, security, and functionality.

### Note

- Your VAIO computer must be connected to the Internet to download the updates.

## To use Windows Update

Windows Update enables you to make your VAIO computer more stable.

1. Click  (Start), All Programs, and Windows Update.
2. Follow the on-screen instructions.

## To use VAIO Update

VAIO Update automatically notifies you of new updates available on the Internet then downloads and installs them on your VAIO computer.

1. Click  (Start), All Programs, and VAIO Care.
2. After VAIO Care starts, click VAIO Software and VAIO Update.
3. Follow the on-screen instructions.

## To update antivirus software

Help protect your VAIO computer against security threats by keeping Internet security

programs current with the latest updates. You can download and install the updates from the website of the manufacturer.

1. Click  (Start), All Programs, and select the antivirus software.
2. Follow the on-screen instructions to complete the updates.

[^ Go to top](#)

---

## Solving Problems on Your VAIO Computer Using VAIO Care

With VAIO Care, you can regularly conduct performance checks and system tune-ups on your VAIO computer to keep it running at optimum level. Launch VAIO Care whenever a problem arises.

VAIO Care will provide appropriate measures and support information to solve the problem.

### To launch VAIO Care

Press the ASSIST button while your VAIO computer is on.  
Below is an example of a screenshot in English.



\* Design and content of the screen are subject to change.

### Hint

- Alternatively, click  (Start), All Programs, and VAIO Care to launch VAIO Care.
- Refer to the help file included with VAIO Care for more information.
- Pressing the ASSIST button while your VAIO computer is off launches VAIO Care Rescue. VAIO Care Rescue can be used to recover the computer in case of emergency, for example, when Windows does not start.

[^ Go to top](#)

---

## Finding Support Information

The Sony online support website provides instant access to information on commonly encountered problems. You can find support information such as the support website URL in Contact & Support on VAIO Care or the supplied Quick Start Guide.

[^ Go to top](#)

---

## Trademarks

- SONY and the SONY logo are registered trademarks of Sony Corporation.

- VAIO, the VAIO logo, and other Sony product or service names are trademarks or registered trademarks of Sony Corporation or any of its affiliates.
- Windows and the Windows logo are either registered trademarks or trademarks of Microsoft Corporation in the United States and/or other countries.
- All other names of system, products, and services are trademarks of their respective owners.
- In the manual, the TM or (R) marks are not specified.

[^ Go to top](#)

---

Copyright 2012 Sony Corporation

---



▶ [Troubleshooting](#)

**How to Use**

- [Parts Description](#)
- [Setup](#)
- [Network / Internet](#)
- [Connections](#)
- [Settings](#)
- [View](#)
- [Playback](#)
- [Backup / Recovery](#)
- [Security](#)
- [Other Operations](#)
- [Notifications](#)
- [MONITOR Function](#)

**Parts and Controls of the Keyboard**

Describes the features of the keyboard, such as keys, buttons and indicator lights.

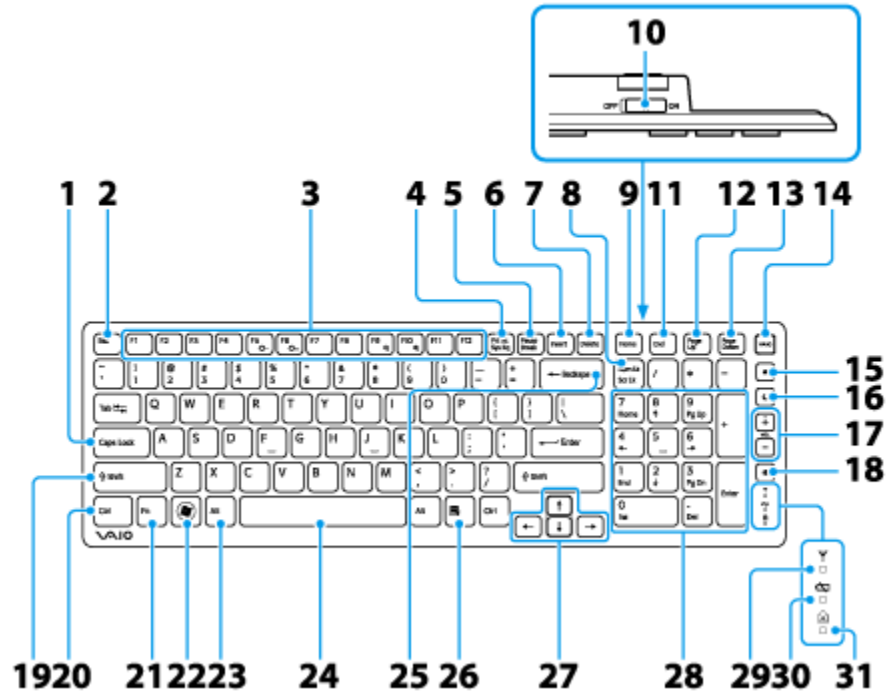

1. Caps Lock key [\[Details\]](#)
2. Esc key
3. Function keys [\[Details\]](#)
4. Prt Sc key
5. Pause / Break key
6. Insert key
7. Delete key
8. Num Lk / Scr Lk key [\[Details\]](#)
9. Home key
10. Power switch of the keyboard
11. End key
12. Page Up key
13. Page Down key
14. VAIO button [\[Details\]](#)
15. Drive eject button [\[Details\]](#)
16. Sleep button [\[Details\]](#)
17. Volume control buttons [\[Details\]](#)
19. Ctrl key
20. Fn key
21. Left arrow key
22. Home key
23. Left arrow key
24. Spacebar
25. Right arrow key
26. End key
27. Right arrow key
28. Enter key
29. VAIO button
30. Sleep button
31. Volume control buttons

**Note**

- You cannot change the volume level when using an input state other than PC, such

as HDMI/VIDEO input function.

18.  Muting button [\[Details\]](#)

**Note**

- You cannot turn off the sound when using an input state other than PC, such as HDMI/VIDEO input function.

19. Shift key

20. Ctrl key

21. Fn key [\[Details\]](#)

22.  (Windows) key

23. Alt key

24. Space bar

25. Backspace key

26. Applications key

27. Directional arrow keys

28. Numeric keypad

29.  Connect indicator [\[Details\]](#)

30.  Battery indicator [\[Details\]](#)

31.  Caps lock indicator [\[Details\]](#)

Hint

- There is a raised dot on the F, J and 5 keys.
- After 10 minutes of idle time, the keyboard enters the power saving mode and all indicator lights turn off.

---

Related Topic

[Replacing the AA Battery of the Keyboard](#)

[Checking the Remaining Battery Power of the Keyboard](#)

[About the Usage Environment for the Keyboard](#)

[Connecting the Wireless Keyboard](#)

---

[▶ Troubleshooting](#)**How to Use**[Parts Description](#)[Setup](#)[Network / Internet](#)[Connections](#)[Settings](#)[View](#)[Playback](#)[Backup / Recovery](#)[Security](#)[Other Operations](#)[Notifications](#)[MONITOR Function](#)

## About the Usage Environment for the Keyboard

This section explains how to use the wireless keyboard.

You can use the wireless keyboard up to 33 ft. / 10 m away from your VAIO computer.

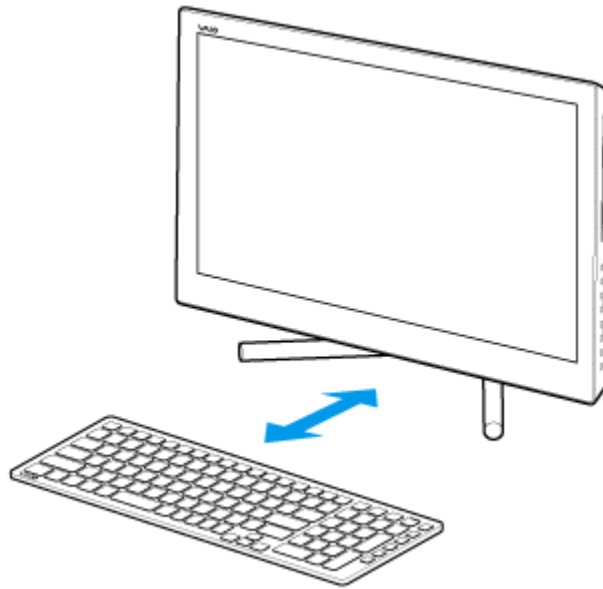
**Note**

- Do not allow water to enter the wireless keyboard as malfunction may result.
- Depending on the usage environment, the communication range between the wireless keyboard and your VAIO computer may be less than 33 ft. / 10 m.
- If you use the wireless keyboard too close to your VAIO computer (within 4 inches / 10 cm), wireless communication may be affected and keyboard input may become unstable. We recommend that you use the wireless keyboard at least 6 inches / 15 cm away from metal objects and your VAIO computer.

**Related Topic**[Connecting the Wireless Keyboard](#)

[▶ Troubleshooting](#)

## How to Use

---

[Parts Description](#)

---

[Setup](#)

---

[Network / Internet](#)

---

[Connections](#)

---

[Settings](#)

---

[View](#)

---

[Playback](#)

---

[Backup / Recovery](#)

---

[Security](#)

---

[Other Operations](#)

---

[Notifications](#)

---

[MONITOR Function](#)

---

## Changing the Button Assignment (VAIO Button)

You can change the current task assigned to the VAIO button. [\[Details\]](#)

To change the button assignment, you need to log onto your VAIO computer as a user with administrative rights, such as a computer administrator.

1. Press and hold down the VAIO button.  
The settings window appears.
  2. Change the current task to your desired one.  
You can select a task from the list.
  3. Click OK.
-

[▶ Troubleshooting](#)

## How to Use

---

[Parts Description](#)

---

[Setup](#)

---

[Network / Internet](#)

---

[Connections](#)

---

[Settings](#)

---

[View](#)

---

[Playback](#)

---

[Backup / Recovery](#)

---

[Security](#)

---

[Other Operations](#)

---

[Notifications](#)

---

[MONITOR Function](#)

---



## Checking the Caps Lock / Num Lock / Scroll Lock States

You can check if the keyboard is in the Caps Lock/Num Lock/Scroll Lock states by the indicator light of the keyboard and the icons in the notification area.



To check if the keyboard is in the Caps Lock state

1. Check if the  Caps lock indicator light is on.

To check if the keyboard is in the Num Lock/Scroll Lock state

1. Check if the  Num lock icon or  Scroll lock icon in the notification area is green.

### Hint

- To make the  Num lock icon and  Scroll lock icon always visible in the notification area of the desktop, click  in the notification area, click Customize..., and then change the behavior of the icons to Show icon and notifications.

---

### Related Topic

[Parts and Controls of the Keyboard](#)

---

## ▶ Troubleshooting

### How to Use

Parts Description

Setup

Network / Internet

Connections

Settings

View

Playback

Backup / Recovery

Security

Other Operations

Notifications

MONITOR Function

## Checking the Remaining Battery Power of the Keyboard

The remaining battery power of the keyboard can be checked by the battery indicator.

1. Check the battery indicator of the keyboard.



It blinks when the battery is running out of power.

The indicator is only a guide and may not show the remaining battery power accurately, depending on the AA battery.

#### Hint

- If you intend not to use the keyboard for a long time, slide the power switch to OFF to extend battery life.

#### Related Topic

[Parts and Controls of the Keyboard](#)

[Replacing the AA Battery of the Keyboard](#)

[▶ Troubleshooting](#)**How to Use**[Parts Description](#)[Setup](#)[Network / Internet](#)[Connections](#)[Settings](#)[View](#)[Playback](#)[Backup / Recovery](#)[Security](#)[Other Operations](#)[Notifications](#)[MONITOR Function](#)

## Combinations and Functions with the Fn Key

Press and hold down the Fn key and another key simultaneously to perform a keyboard shortcut action.

For example, to adjust the LCD brightness: Fn+F5 → Press and hold down the Fn key, then press the F5 key.

Some keyboard functions can only be used while Windows is running.

Fn + / (F5/F6)

Press the button repeatedly to adjust the LCD brightness of your computer screen. [\[Details\]](#)

To decrease lighting intensity, press the Fn+F5 keys.

To increase lighting intensity, press the Fn+F6 keys.

Fn + / (F9/F10)

Changes the size of an image or a document displayed on the running software.

To zoom out, press the Fn+F9 keys.

To zoom in, press the Fn+F10 keys.

This function may not be available depending on the software you use.

Fn + Scr Lk (Scroll Lock)

Works differently depending on the software you use. Refer to the help file included with the software for more information.

[▶ Troubleshooting](#)

## How to Use

[Parts Description](#)[Setup](#)[Network / Internet](#)[Connections](#)[Settings](#)[View](#)[Playback](#)[Backup / Recovery](#)[Security](#)[Other Operations](#)[Notifications](#)[MONITOR Function](#)

## Connecting the Wireless Keyboard

If you cannot use the wireless keyboard supplied with the computer, it is likely that wireless connection setup is required between the wireless keyboard and your VAIO computer. Turn on your VAIO computer before connecting the keyboard.

1. Check that an AA battery is inserted in the wireless keyboard you want to connect, and then slide the keyboard's power switch to OFF.
2. While pressing and holding the right Ctrl key of the keyboard, slide the keyboard's power switch to ON.

The connect indicator turns on.

Hint

- Keep the Ctrl key pressed.
3. With the right Ctrl key pressed, put the keyboard immediately in front of your VAIO computer's screen.
- The connect indicator turns off and the connection is then established.

### Note

- The connection procedure is not usually required to use the wireless keyboard with your VAIO computer.
- Do not perform the connection procedure if you can use the wireless keyboard normally. Doing so may cause computer malfunction.

### Related Topic

[About the Usage Environment for the Keyboard](#)



[▶ Troubleshooting](#)

## How to Use

[Parts Description](#)[Setup](#)[Network / Internet](#)[Connections](#)[Settings](#)[View](#)[Playback](#)[Backup / Recovery](#)[Security](#)[Other Operations](#)[Notifications](#)[MONITOR Function](#)

## Replacing the AA Battery of the Keyboard

Change the AA battery in the keyboard when the battery power becomes low.

1. Set the power switch of the keyboard to OFF.

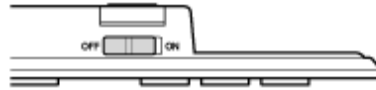

2. Turn over the keyboard, and then push the center of the cover in the direction shown in the illustration below.

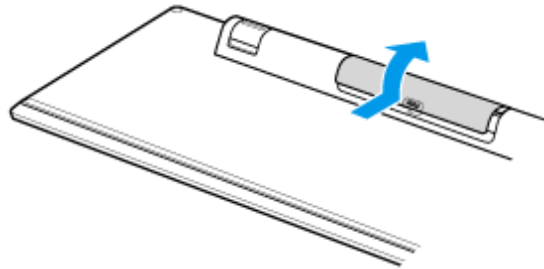

3. Remove the old battery and insert a new AA alkaline battery (minus (-) end first), then close the cover.

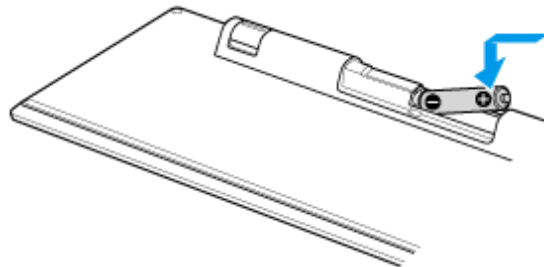

4. Set the power switch of the keyboard to ON.

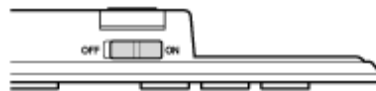

### Note

- Use a new AA alkaline replacement battery.
- If you do not intend to use the keyboard for a while, set the power switch of the keyboard to OFF. If you do not intend to use the keyboard for an extended period of time, remove its AA battery.
- When the battery power becomes low, replace with a new AA battery promptly. Keeping a depleted battery in the keyboard may cause battery leakage.
- Since the keyboard cannot be used with a commercially available rechargeable battery, use a non-rechargeable AA battery. If you use a rechargeable battery, battery leakage may occur, resulting in a malfunction.
- Do not recharge a dry cell AA battery.

- Refer to the supplied safety information manual.

---

Related Topic

[Parts and Controls of the Keyboard](#)

[Checking the Remaining Battery Power of the Keyboard](#)

---



» [Troubleshooting](#)

**How to Use**

- [Parts Description](#)
- [Setup](#)
- [Network / Internet](#)
- [Connections](#)
- [Settings](#)
- [View](#)
- [Playback](#)
- [Backup / Recovery](#)
- [Security](#)
- [Other Operations](#)
- [Notifications](#)
- [MONITOR Function](#)





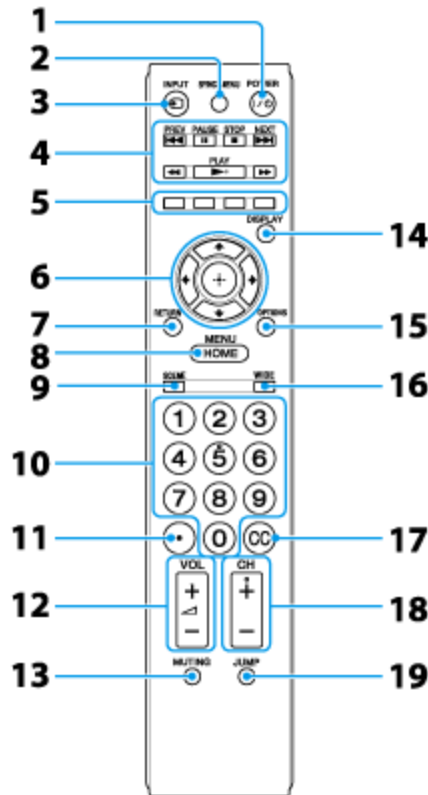

**Parts and Controls of the Remote Commander**  
 <TV tuner board installed models>

Describes the features of the remote commander, such as buttons.



1. POWER button  
Press to turn on the TV.
2. SYNC MENU button  
Press to display the “BRAVIA” Sync Menu and then select connected HDMI equipment from HDMI Device Selection.
- Note
  - Control for HDMI (“BRAVIA” Sync) is only available for connected Sony equipment that has the “BRAVIA” Sync logo or is compatible with “Control for HDMI.”
3. INPUT button  
Press to display a list of inputs.
4. Operating buttons A
  - PREV / NEXT buttons  
Go to the beginning of the previous/next title/chapter/scene/track.
  - STOP button  
Stop playback.
  - PAUSE button  
Pause or re-start playback.
  - ◀▶ buttons

Fast reverse/fast forward the disc when pressed during playback.

5. Color buttons  
When the color buttons are available, an operation guide appears on the screen.
  6. Operating buttons B  
Press  /  /  /  to move the on-screen cursor. Press  to select/confirm a highlighted item.
  7. RETURN button  
Press to return to the previous screen or exit from the menu.
  8. HOME button  
Press to display the menu screen.
  9. SCENE button  
Press to display the Scene Select menu. Select the desired scene option for optimum sound and picture quality.
  10. 0-9 buttons  
Press 0-9 to select a channel.
  11.  button  
Use with 0-9 to select digital channels. For example, to enter 2.1, press 2, , 1.
  12. VOL +/- buttons  
Press to adjust the volume.
  13. MUTING button  
Press to turn off the sound. Press again to restore the sound.
  14. DISPLAY button  
Press once to display information about the channel/program/input you are viewing. The information will time out in a few seconds or press again to exit.
  15. OPTIONS button  
Press to display a list of convenient functions and menu shortcuts. The menu items vary based on the current input and/or content.
  16. WIDE button  
Press to change the wide mode.
  17. CC button  
Press to turn closed captions/subtitles on or off (when the feature is available).
  18. CH +/- buttons  
Press to select the next (+) or previous (-) channel.
  19. JUMP button  
Press to jump back and forth between two channels or inputs. The TV alternates between the current channel or input and the last channel or input that was selected.
-

[▶ Troubleshooting](#)**How to Use**[Parts Description](#)[Setup](#)[Network / Internet](#)[Connections](#)[Settings](#)[View](#)[Playback](#)[Backup / Recovery](#)[Security](#)[Other Operations](#)[Notifications](#)[MONITOR Function](#)

## Replacing the AA Battery of the Remote Commander <TV tuner board installed models>

If the remote commander does not operate properly, replace the batteries.

1. Turn over the remote commander and remove the battery compartment cover.
2. Remove both old batteries and insert two new AA batteries (minus (-) end of each battery first), then close the cover.

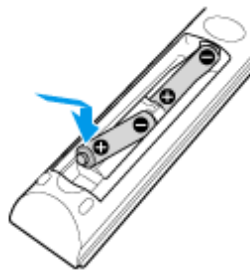
**Note**

- If the remote commander is not going to be used for an extended period of time, remove the batteries.
- Since the remote cannot be used with the commercially available rechargeable batteries, use the non-rechargeable AA batteries. If you use the rechargeable batteries, battery leakage may occur, resulting in a malfunction.
- When the battery power becomes low, replace with the battery promptly. Keeping depleted batteries in the remote may cause battery leakage.
- Do not recharge the dry cell AA batteries.

[▶ Troubleshooting](#)**How to Use**[Parts Description](#)[Setup](#)[Network / Internet](#)[Connections](#)[Settings](#)[View](#)[Playback](#)[Backup / Recovery](#)[Security](#)[Other Operations](#)[Notifications](#)[MONITOR Function](#)**Parts and Controls of the Mouse**

Describes the features of the mouse, such as buttons.

Top

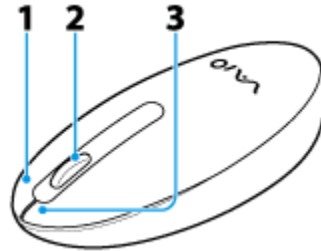

1. Right button
2. Central wheel
3. Left button

Bottom

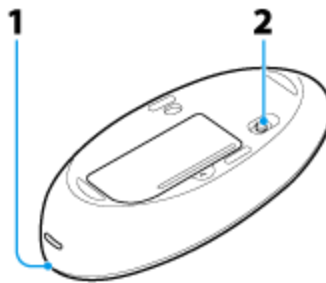

1. Status light [\[Details\]](#)
2. Power switch of the mouse

Related Topic

[Replacing the AA Battery of the Mouse](#)

[Checking the Remaining Battery Power of the Mouse](#)

[About the Usage Environment for the Mouse](#)

[Connecting the Wireless Mouse](#)

[▶ Troubleshooting](#)

## How to Use

[Parts Description](#)[Setup](#)[Network / Internet](#)[Connections](#)[Settings](#)[View](#)[Playback](#)[Backup / Recovery](#)[Security](#)[Other Operations](#)[Notifications](#)[MONITOR Function](#)

## About the Usage Environment for the Mouse

This section explains how to use the wireless mouse.

You can use the wireless mouse up to 33 ft. / 10 m away from your VAIO computer.

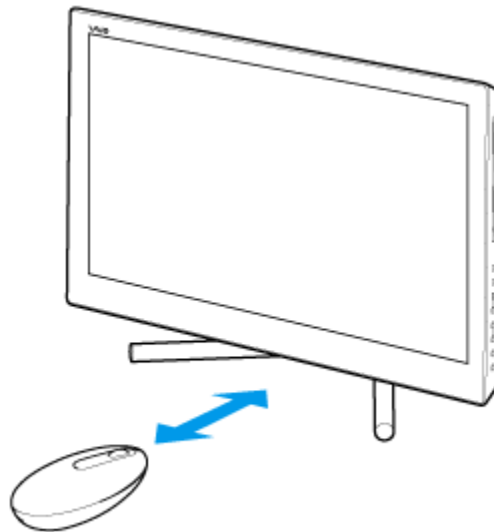

### Note

- The wireless mouse supplied with your VAIO computer uses a laser sensor. Mouse operation may become unstable depending on the usage environment.
- Depending on the usage environment, the communication range between the wireless mouse and your VAIO computer may be less than 33 ft. / 10 m.
- If you use the wireless mouse too close to your VAIO computer (within 4 inches / 10 cm), wireless communication may be affected and mouse operation may become unstable. We recommend that you use the wireless mouse at least 6 inches / 15 cm away from metal objects and your VAIO computer.

### Related Topic

[Connecting the Wireless Mouse](#)

[▶ Troubleshooting](#)

## How to Use

---

[Parts Description](#)

---

---

[Setup](#)

---

---

[Network / Internet](#)

---

---

[Connections](#)

---

---

[Settings](#)

---

---

[View](#)

---

---

[Playback](#)

---

---

[Backup / Recovery](#)

---

---

[Security](#)

---

---

[Other Operations](#)

---

---

[Notifications](#)

---

---

[MONITOR Function](#)

---

## Connecting the Wireless Mouse

If you cannot use the wireless mouse supplied with your VAIO computer, it is likely that wireless connection setup is required between the wireless mouse and the computer. Turn on your VAIO computer before connecting the mouse.

1. Check that an AA battery is inserted in the wireless mouse you want to connect, and then slide the mouse's power switch to OFF.
2. While pressing and holding the central wheel of the mouse, slide the mouse's power switch to ON.

The status light turns on.

Hint

- Keep the central wheel pressed.
3. With the central wheel pressed, put the mouse immediately in front of your VAIO computer's screen.
- The status light turns off and the connection is then established.

### Note

- The connection procedure is not usually required to use the wireless mouse with your VAIO computer.
- Do not perform the connection procedure if you can use the wireless mouse normally. Doing so may cause computer malfunction.

---

### Related Topic

[About the Usage Environment for the Mouse](#)

---



[▶ Troubleshooting](#)

## How to Use

[Parts Description](#)[Setup](#)[Network / Internet](#)[Connections](#)[Settings](#)[View](#)[Playback](#)[Backup / Recovery](#)[Security](#)[Other Operations](#)[Notifications](#)[MONITOR Function](#)

## Replacing the AA Battery of the Mouse

Change the AA battery in the mouse when the battery power becomes low.

1. Set the power switch of the mouse to OFF.

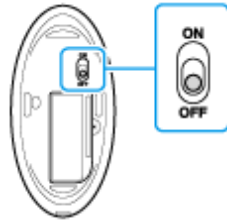

2. Turn the mouse upside down. Hold the center of the cover and slide the battery cover in the direction of the arrow.



3. Remove the old battery and insert a new AA alkaline battery (minus (-) end first), then close the cover.

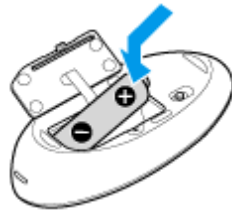

4. Set the power switch of the mouse to ON.

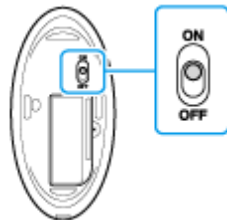

### Note

- Use a new AA alkaline replacement battery.
- If you do not intend to use the mouse for a while, set the power switch of the mouse to OFF. If you do not intend to use the mouse for an extended period of time, remove its AA battery.
- When the battery power becomes low, replace with the battery promptly. Keeping a depleted battery in the mouse may cause battery leakage.
- Since the mouse cannot be used with a commercially available rechargeable battery, use a non-rechargeable AA battery. If you use a rechargeable battery, battery leakage

may occur, resulting in a malfunction.

- Do not recharge a dry cell AA battery.
- Refer to the supplied safety information manual.

---

Related Topic

[Parts and Controls of the Mouse](#)

[Checking the Remaining Battery Power of the Mouse](#)

---

[Troubleshooting](#)

**How to Use**

- [Parts Description](#)
- [Setup](#)
- [Network / Internet](#)
- [Connections](#)
- [Settings](#)
- [View](#)
- [Playback](#)
- [Backup / Recovery](#)
- [Security](#)
- [Other Operations](#)
- [Notifications](#)
- [MONITOR Function](#)

**Parts and Controls on the Back**

Describes the features on the back of the VAIO computer, such as connection ports.

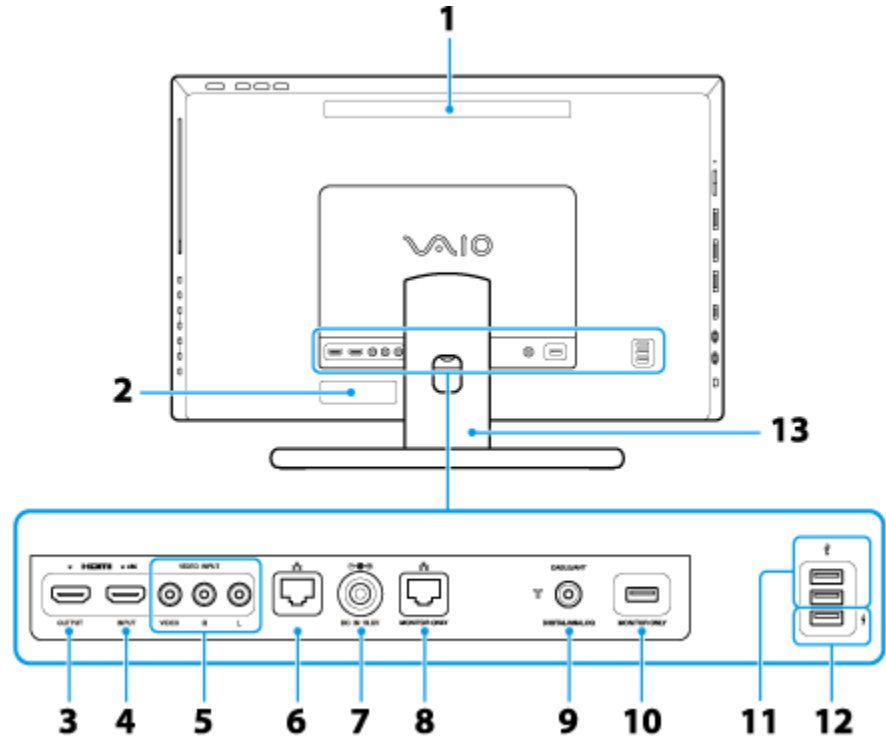

1. Air exhaust vent
2. Rating plate
3. HDMI OUTPUT port [\[Details\]](#)
4. HDMI INPUT port [\[Details\]](#)
5. VIDEO INPUT jacks [\[Details\]](#)
6. LAN port [\[Details\]](#)  
This LAN port is for use by the PC. Use this port to make LAN connection on Windows.
7. DC IN port [\[Details\]](#)
8. MONITOR ONLY LAN port [\[Details\]](#)  
Use this port to make a Digital Living Network Alliance (DLNA) connection without starting Windows. This port cannot be used by the PC.
9. CABLE/ANT (DIGITAL/ANALOG) port <TV tuner board installed models> [\[Details\]](#)
10. MONITOR ONLY USB port [\[Details\]](#)  
Use this port to view photos or play back music files without starting Windows. USB devices connected to this port cannot be accessed in Windows.
11. USB ports [\[Details\]](#)
12. USB port [\[Details\]](#)

This USB port supports USB charging. [\[Details\]](#)

### 13. Foot stand

#### Note

- The air exhaust vent may get hot during use. Take care when touching it.

---

#### Related Topic

[Parts and Controls on the Front](#)

[Parts and Controls on the Sides](#)

[Parts and Controls on the Bottom](#)

---

[▶ Troubleshooting](#)

**How to Use**

- [Parts Description](#)

---

- [Setup](#)

---

- [Network / Internet](#)

---

- [Connections](#)

---

- [Settings](#)

---

- [View](#)

---

- [Playback](#)

---

- [Backup / Recovery](#)

---

- [Security](#)

---

- [Other Operations](#)

---

- [Notifications](#)

---

- [MONITOR Function](#)

---

**Parts and Controls on the Bottom**

Describes the features on the bottom of the VAIO computer.

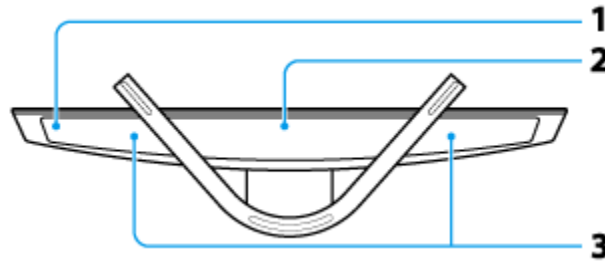

1. Built-in microphone (monaural)
2. Subwoofer
3. Built-in speakers (stereo)

Related Topic

- [Parts and Controls on the Front](#)
- [Parts and Controls on the Sides](#)
- [Parts and Controls on the Back](#)

▶ Troubleshooting

How to Use

- Parts Description
- Setup
- Network / Internet
- Connections
- Settings
- View
- Playback
- Backup / Recovery
- Security
- Other Operations
- Notifications
- MONITOR Function

Parts and Controls on the Front

Describes the features on the front of the VAIO computer, such as buttons and indicator lights.

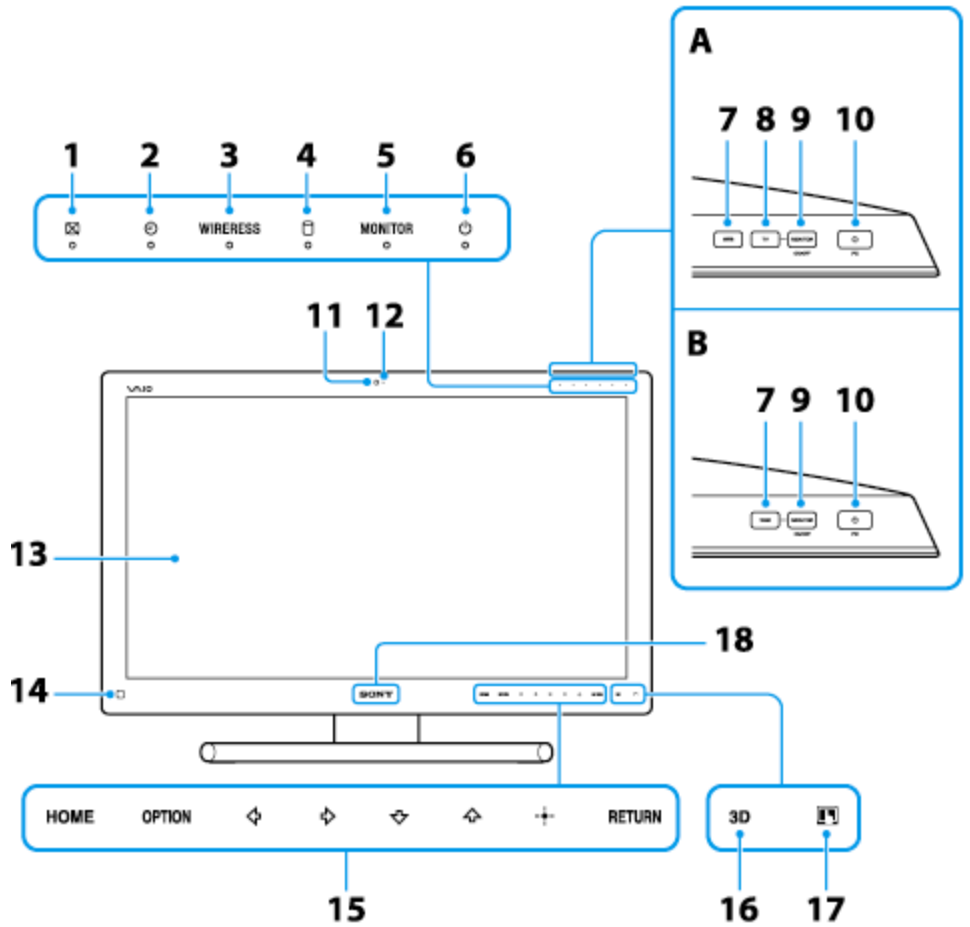

1. Picture off indicator [\[Details\]](#)  
While using the Picture Off function, the picture off indicator lights in orange.
2. Timer indicator [\[Details\]](#)  
When you set the timer, the timer indicator light turns on in orange.
3. WIRELESS indicator [\[Details\]](#)
4. Disc drive indicator
5. MONITOR indicator [\[Details\]](#)
6. PC power indicator [\[Details\]](#)

A. TV tuner board installed models

7. WEB button [\[Details\]](#)
8. TV button
9. MONITOR power button [\[Details\]](#)

10.  PC power button [\[Details\]](#)

#### B. Other models

7. WEB button [\[Details\]](#)

9. MONITOR power button [\[Details\]](#)

10.  PC power button [\[Details\]](#)

11. Built-in camera [\[Details\]](#)

12. Built-in camera indicator [\[Details\]](#)

13. LCD screen or touch screen <Touch screen equipped models> [\[Details\]](#)

14. Remote sensor <TV tuner board installed models>

15. Edge Access <Touch screen equipped models>

Move your hand over Edge Access to light up its buttons.

The same functions are assigned to both the Edge Access buttons, and the monitor operation buttons on the right side of the VAIO computer [\[Details\]](#).

16. 3D button <3D-capable LCD screen equipped models>

17.  VAIO Touch Portal button <Touch screen equipped models> [\[Details\]](#)

18. Logo lamp [\[Details\]](#)

#### Notes on the LCD screen

The LCD screen is manufactured using high-precision technology. You may, however, see tiny black points and/or bright points (red, blue, or green) that continuously appear on the LCD screen. The ratio of defective pixels to all available pixels of the LCD screen is less than 0.0006 %. Also, depending on the viewing angle, uneven stripes of changes in color and luminance may appear. These are normal results of the LCD screen construction and do not indicate a malfunction. Take note that returns and replacements are not accepted.

---

#### Related Topic

[Parts and Controls on the Sides](#)

[Parts and Controls on the Back](#)

[Parts and Controls on the Bottom](#)

---

[▶ Troubleshooting](#)

**How to Use**

- [Parts Description](#)

---

- [Setup](#)

---

- [Network / Internet](#)

---

- [Connections](#)

---

- [Settings](#)

---

- [View](#)

---

- [Playback](#)

---

- [Backup / Recovery](#)

---

- [Security](#)

---

- [Other Operations](#)

---

- [Notifications](#)

---

- [MONITOR Function](#)

---

**Parts and Controls on the Sides**

Describes the features on the sides of the VAIO computer, such as connection ports.

Right side

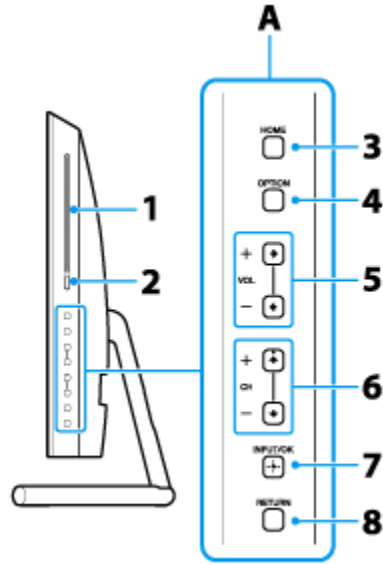

- 1. Optical disc drive [\[Details\]](#)
- 2. Drive eject button [\[Details\]](#)





**A. MONITOR operation buttons [\[Details\]](#)**

- 3. HOME button
- 4. OPTION button
- 5. ◀ / ▶ buttons / VOL (Volume) buttons
- 6. ▲ / ▼ buttons / CH (Channel) buttons (TV tuner board installed models)
- 7. INPUT/OK button
- 8. RETURN button

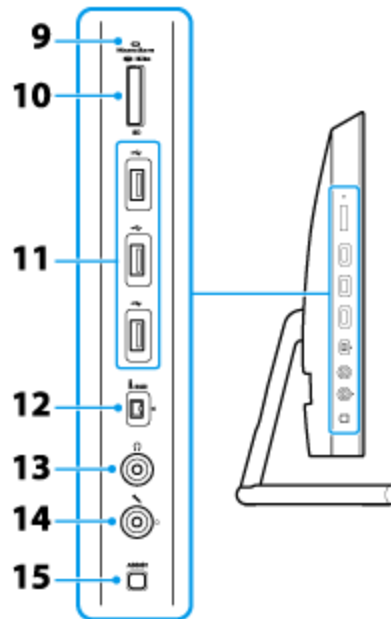
Left side





9. Media access indicator (“Memory Stick Duo” [\[Details\]](#), SD memory card [\[Details\]](#))
10. “Memory Stick Duo” / SD memory card combined slot (“Memory Stick Duo” [\[Details\]](#), SD memory card [\[Details\]](#))  
“Memory Stick Duo” and an SD memory card cannot be inserted into the slot simultaneously.
11.  USB ports [\[Details\]](#)
12.  i.LINK 4-pin (S400) port [\[Details\]](#)
13.  Headphones jack [\[Details\]](#)
14.  Microphone jack [\[Details\]](#)
15. ASSIST button [\[Details\]](#)

---

#### Related Topic

[Parts and Controls on the Front](#)

[Parts and Controls on the Back](#)

[Parts and Controls on the Bottom](#)

---

[▶ Troubleshooting](#)

## How to Use

---

[Parts Description](#)

---

[Setup](#)

---

[Network / Internet](#)

---

[Connections](#)

---

[Settings](#)

---

[View](#)

---

[Playback](#)

---

[Backup / Recovery](#)

---

[Security](#)

---

[Other Operations](#)

---

[Notifications](#)

---

[MONITOR Function](#)

---

## About Factory Setting (MONITOR Function)

Returns the current settings to the initial settings.

---

Related Topic

[Displaying the Menu Screen \(MONITOR Function\)](#)

---

[▶ Troubleshooting](#)

## How to Use

---

[Parts Description](#)

---

---

[Setup](#)

---

---

[Network / Internet](#)

---

---

[Connections](#)

---

---

[Settings](#)

---

---

[View](#)

---

---

[Playback](#)

---

---

[Backup / Recovery](#)

---

---

[Security](#)

---

---

[Other Operations](#)

---

---

[Notifications](#)

---

---

[MONITOR Function](#)

---

## About the ASSIST Button

Press the ASSIST button to perform regular maintenance of your VAIO computer or to solve problems you might encounter when using the computer.

While the computer is on, the ASSIST button starts VAIO Care.

While the computer is off, the ASSIST button starts VAIO Care Rescue.

VAIO Care Rescue can be used to recover the computer in case of emergency, for example, when Windows does not start.

---

### Related Topic

[Keeping Your VAIO Computer in Optimum Condition \(VAIO Care\)](#)

[Recovering from the Recovery Area](#)

[Backing Up Your Data when You cannot Start Windows](#)

[Restoring Your Data with VAIO Data Restore Tool](#)

---

[▶ Troubleshooting](#)

## How to Use

---

[Parts Description](#)

---

[Setup](#)

---

[Network / Internet](#)

---

[Connections](#)

---

[Settings](#)

---

[View](#)

---

[Playback](#)

---

[Backup / Recovery](#)

---

[Security](#)

---

[Other Operations](#)

---

[Notifications](#)

---

[MONITOR Function](#)

---

## About the Clock / Timers Settings (MONITOR Function)

This topic explains clock or timers settings.

This setting allows you to use the following functions/features.

- Sets the current time manually.
- Turns on the display from standby mode at the time you set, and turns it off after a preset time.

### Note

- The timer setting is not available for PC.

---

### Related Topic

[Displaying the Menu Screen \(MONITOR Function\)](#)

---

[▶ Troubleshooting](#)**How to Use**

---

[Parts Description](#)

---

[Setup](#)

---

[Network / Internet](#)

---

[Connections](#)

---

[Settings](#)

---

[View](#)

---

[Playback](#)

---

[Backup / Recovery](#)

---

[Security](#)

---

[Other Operations](#)

---

[Notifications](#)

---

[MONITOR Function](#)

---

## About the Front Panel Illumination Settings (MONITOR Function)

Turns the logo lamp on the front of your VAIO computer on or off.

---

Related Topic

[Displaying the Menu Screen \(MONITOR Function\)](#)

---

[▶ Troubleshooting](#)

## How to Use

---

[Parts Description](#)

---

[Setup](#)

---

[Network / Internet](#)

---

[Connections](#)

---

[Settings](#)

---

[View](#)

---

[Playback](#)

---

[Backup / Recovery](#)

---

[Security](#)

---

[Other Operations](#)

---

[Notifications](#)

---

[MONITOR Function](#)

---

## About the MONITOR Indicator

This topic explains about the conditions of the MONITOR indicator.

- The MONITOR indicator (green) turns on when the MONITOR power is ON.
- The MONITOR indicator (orange) turns on when the MONITOR power is OFF by the remote controlling or the timer settings.

### Hint

- The MONITOR indicator (green) and the  (Picture Off) indicator (orange) turn on while the Picture Off function is working.

---

### Related Topic

[Turning Off the LCD Screen](#)[About the Clock / Timers Settings \(MONITOR Function\)](#)[Enjoying Sounds Only \(Picture Off\)](#)

---

## ▶ Troubleshooting

### How to Use

Parts Description

Setup

Network / Internet

Connections

Settings

View

Playback

Backup / Recovery

Security

Other Operations

Notifications

MONITOR Function

## Adding and Removing Memory Modules

If you want to increase your computer's speed or improve performance when running programs simultaneously, increase the amount of memory by installing optional memory modules.

Before you upgrade your computer's memory, see Notes on Adding and Removing Memory Modules. [\[Details\]](#)

If you install memory modules into two or more slots, the dual-channel mode is enabled to help improve performance.

The type of module and the amount of memory installed on your computer may differ depending on the model.

1. Turn off your VAIO computer and peripheral devices, and disconnect the power cord and all connection cables.
2. Wait for a while until your VAIO computer cools down.  
The inner parts of your VAIO computer may be hot just after turning off. Be careful to avoid burns while handling your VAIO computer in this state.
3. Remove the back panel of your VAIO computer.

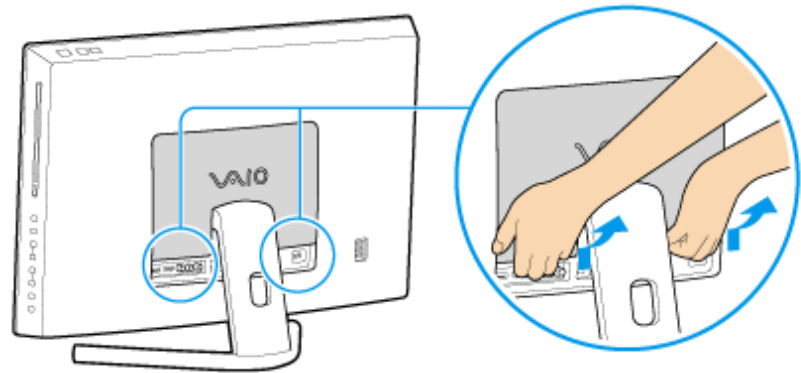

4. Lay a clean cloth on a level, flat surface, place your VAIO computer on it as illustrated below. Remove the screws with a cross slot screwdriver to open the memory module compartment cover.  
On some models, captive screws are used on the memory module compartment cover and cannot be detached from the cover.

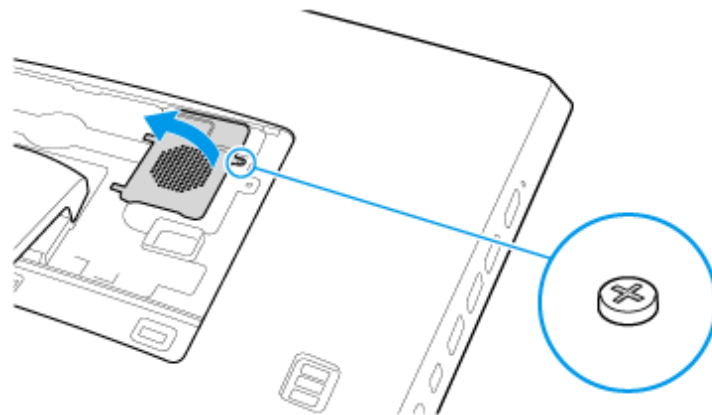

5. Touch an external metal object to discharge static electricity.  
Do not touch any metal parts inside your VAIO computer.
6. If there is no free slot, remove the currently installed memory module. Pull the latches in the direction of the arrows to pop up the module at an angle (1), then pull the module out in the direction of the arrow (2).

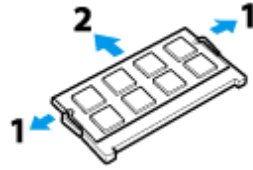

7. Remove the new memory module from its antistatic bag.
8. Hold the memory module by its edge and slide it into the memory module slot with its end terminal facing downward while aligning the notch on the module with the small projection in the slot.  
If you intend to install only one memory module, be sure to install it into the lower slot.



9. Hold the memory module by its edge and push in until it clicks into place as shown in the illustration.  
The latches on both sides of the slot snap into place to secure the module. Do not touch any ICs (black components) on the memory module.

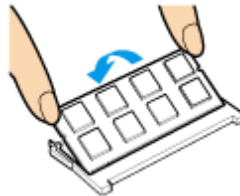

10. Replace the memory module compartment cover and secure it with the screws you removed in step 3.
11. Re-attach the back panel of your VAIO computer.

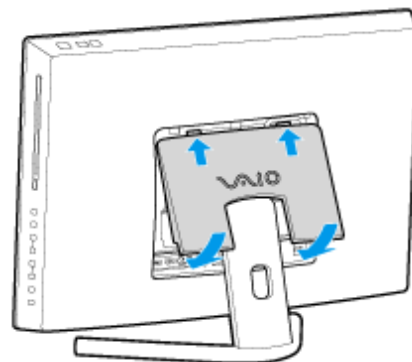

**Note**

- Insert the tabs of the panel in the slots, and press it down until you hear a click.

12. Connect all connection cables and peripherals that you removed in Step 1, and turn on the computer.



13. Check that the amount of system memory has correctly changed. [\[Details\]](#)  
If the amount of indicated system memory is correct, memory module installation was successful.

---

Related Topic

[Notes on Adding and Removing Memory Modules](#)

---

[▶ Troubleshooting](#)

## How to Use

---

[Parts Description](#)

---

[Setup](#)

---

[Network / Internet](#)

---

[Connections](#)

---

[Settings](#)

---

[View](#)

---

[Playback](#)

---

[Backup / Recovery](#)

---

[Security](#)

---

[Other Operations](#)

---

[Notifications](#)

---

[MONITOR Function](#)

---

## Booting Your VAIO Computer from External Devices

You can boot your VAIO computer from external devices, such as an optical disc drive or a USB floppy disk drive, by using the BIOS function.

1. Connect an external device to your VAIO computer and turn on the computer.
2. Press the F11 key repeatedly until the VAIO logo disappears.  
The booting process from the external device starts. If your VAIO computer does not boot up, restart the computer and try again.

### Note

- Disconnect all devices from your VAIO computer except for the external device from which you intend to boot up. Some devices cannot be used to boot the computer, or cannot be used with the computer.
  - If an AC adapter is supplied with the external device, be sure to connect it to an AC power source in advance.
-

[▶ Troubleshooting](#)

## How to Use

---

[Parts Description](#)

---

---

[Setup](#)

---

---

[Network / Internet](#)

---

---

[Connections](#)

---

---

[Settings](#)

---

---

[View](#)

---

---

[Playback](#)

---

---

[Backup / Recovery](#)

---

---

[Security](#)

---

---

[Other Operations](#)

---

---

[Notifications](#)

---

---

[MONITOR Function](#)

---

## Checking Supplied Items

Check all items packed with the product before use.

Wireless keyboard

Wireless mouse

Remote commander\*

AA batteries

- Alkaline batteries for the keyboard and mouse (2)
- Manganese batteries for the remote commander (2)\*

\* Not supplied with all models. Availability depends on your computer's specifications.

AC adapter

Power cord

Hint

- No Recovery Media is included because your VAIO computer can be recovered using data stored in the hard disk drive or SSD. See Recovering from the Recovery Area for more information.[\[Details\]](#)
-

[▶ Troubleshooting](#)

## How to Use

---

[Parts Description](#)

---

[Setup](#)

---

[Network / Internet](#)

---

[Connections](#)

---

[Settings](#)

---

[View](#)

---

[Playback](#)

---

[Backup / Recovery](#)

---

[Security](#)

---

[Other Operations](#)

---

[Notifications](#)

---

[MONITOR Function](#)

---

## Customizing Your VAIO Computer

VAIO Control Center allows you to access system information and to change settings of various kinds of functions such as display and sounds.

1. Click  (Start), All Programs, and VAIO Control Center.
2. Select your desired item and change the settings.

### Hint

- Refer to the help file included with VAIO Control Center for more information on each option.
  - Some of the items will not be visible if you log on as a user without administrative rights.
-

▶ Troubleshooting

How to Use

Parts Description

Setup

Network / Internet

Connections

Settings

View

Playback

Backup / Recovery

Security

Other Operations

Notifications

MONITOR Function

## Displaying the Menu Screen (MONITOR Function)

With the menu screen, you can customize the settings and switch the input source.

1. Press the HOME button on the remote, or the HOME button on the right side of your VAIO computer.

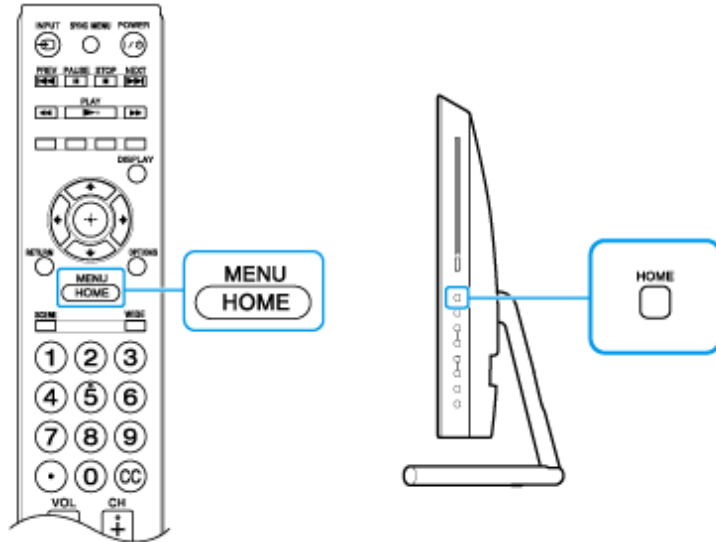

The menu screen appears.

2. Press ◀/▶ on the remote, or ◀/▶ on the right side of the computer, to select category (1).









3. Press ▲/▼ on the remote, or ▲/▼ on the right side of the computer, to select an item in the side bar (2).



4. Press the **+** button on the remote, or the INPUT/OK button on the right side of the computer.

## About the categories in the menu

The category icons organize some settings and features for quick and easy access.

-  (Settings)  
Provides the settings that allow you to customize the input sources other than PC.
-  (TV) <TV tuner board installed models>  
Allows you to select a list of TV channels, or a program guide.
-  (Media)  
Enables selection of media files (photo, music, video) to play in a connected USB storage device or your home network.
-  (Inputs)  
Enables selection of equipment connected to your VAIO computer.
-  (PC)  
Starts Windows.
-  (Favorites/History)  
Displays items in Favorites and recently viewed items.

### Note

- You cannot use the touch screen to operate the menu screen.
- The items you can select may vary depending on the model or the situation.

---

### Related Topic

[Using the Settings Menu \(MONITOR Function\)](#)

---

[▶ Troubleshooting](#)

## How to Use

---

[Parts Description](#)

---

[Setup](#)

---

[Network / Internet](#)

---

[Connections](#)

---

[Settings](#)

---

[View](#)

---

[Playback](#)

---

[Backup / Recovery](#)

---

[Security](#)

---

[Other Operations](#)

---

[Notifications](#)

---

[MONITOR Function](#)

---

## Keeping Your VAIO Computer in Optimum Condition (VAIO Care)

With VAIO Care, you can perform the following operations to keep your VAIO computer running at an optimum level.

- Conduct regular performance checks and tune-ups.
  - Find support information (the support website URL, the contact information phone number, etc.).
  - Launch VAIO Care just by pressing the ASSIST button and search for appropriate measures if you have any problem.
1. Press the ASSIST button while your VAIO computer is on.  
VAIO Care starts.  
Refer to the help file included with VAIO Care for more information.

### Hint

- Alternatively, click  (Start), All Programs, and VAIO Care to start VAIO Care.
- Pressing the ASSIST button while your VAIO computer is off launches VAIO Care Rescue. VAIO Care Rescue can be used to recover the computer in case of emergency, for example, if Windows does not start.

---

### Related Topic

[Recovering from the Recovery Area](#)[Backing Up Your Data when You cannot Start Windows](#)[Restoring Your Data with VAIO Data Restore Tool](#)

---

[▶ Troubleshooting](#)**How to Use**[Parts Description](#)[Setup](#)[Network / Internet](#)[Connections](#)[Settings](#)[View](#)[Playback](#)[Backup / Recovery](#)[Security](#)[Other Operations](#)[Notifications](#)[MONITOR Function](#)

## Notes on Adding and Removing Memory Modules

Before adding or removing memory modules, read the following precautions thoroughly.

- Your VAIO computer and memory modules use high precision components and electronic connector technology. To avoid invalidation of the warranty during your product warranty period, we recommend that:
  - You should contact your dealer to install a new memory module.
  - You should not install a memory module by yourself, if you are not familiar with upgrading memory on a computer.
  - You should not touch the connectors or open the memory module compartment cover.
- For assistance, contact an authorized Sony service/support center. To find the nearest center or agent, refer to online support website. [\[Details\]](#)
- If you add or remove memory modules by yourself, your VAIO computer may result in malfunction or accident caused by breakage of slot and module, or connection mistake. In this case, repair fee will be charged.
- Be careful not to injure your hands or fingers with sharp edges of the memory module, inner components, or circuit boards of your VAIO computer.
- Be careful not to catch your fingers on any inner cables of your VAIO computer, as the cable may become loose or disconnected.
- If your VAIO computer is turned on while liquid such as water or other foreign object remains inside, it may cause a fire. Be sure to remove any foreign objects and attach the memory module compartment cover before turning on your VAIO computer.
- Sony does not guarantee that third party memory modules will work in your VAIO computer. For information on third party memory modules, consult the respective sales dealers.
- Be sure to turn off your VAIO computer and peripherals and disconnect all attachments and connection cables before adding or removing memory modules. Failure to do so may cause damage to the memory module, your VAIO computer, or peripheral devices.
- To prevent damage from electrostatic discharge to memory modules, follow the instructions below:
  - Do not work at a place that produces static electricity easily, such as on a carpet.
  - Before adding or removing memory modules, touch an external metal object from your VAIO computer to eliminate static electricity. Do not touch any metal parts inside the computer.
  - Do not open the memory module package before you are ready to install the module. The package protects the module from ESD (electrostatic discharge). To store the module, cover it with an antistatic bag or a sheet of aluminum foil.
- When holding a memory module, do not touch the chips or electrical terminal of the module.
- Do not insert a memory module into the slot facing in wrong direction. It may cause damage to the module or slot, or cause the circuit board to catch fire.
- Use a screwdriver that matches the size of the screw (such as a miniature screwdriver).
- Do not remove or loosen screws that are not specified to be removed.

### Related Topic

[Adding and Removing Memory Modules](#)[Viewing the System Information](#)





## ▶ Troubleshooting

### How to Use

Parts Description

Setup

Network / Internet

Connections

Settings

View

Playback

Backup / Recovery

Security

Other Operations

Notifications

MONITOR Function

## Preparing for Wall Mounting

Your VAIO computer can be mounted on a wall using a wall mounting bracket (not supplied). It is recommended that you use the Sony SU-WL100 wall mounting bracket. Please use four M4 screws (not supplied) which are compliant with the Video Electronics Standards Association (VESA) standard mounting hole pattern 100mm × 100mm for installing the computer to your mounting bracket.

### Note

- The weight of your VAIO computer is within the range of supported weight of your mounting bracket. See the manual that came with your mounting system for the weight information.
- While your VAIO computer is wall mounted, do not place any objects on top of the computer so as not to break the frame and cause the main unit to fall from the wall, resulting in damage to the computer or personal injuries.

1. Turn off your VAIO computer and peripheral devices, and disconnect the power cord and all connection cables.
2. Wait for a while until the computer cools down.  
The inner parts of the computer may be hot just after turning off. Be careful to avoid burns while handling the computer in this state.
3. Remove the back panel of the computer.

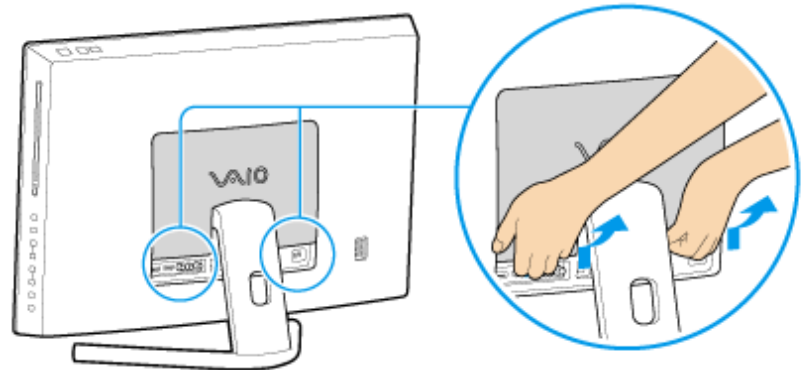

4. Lay a clean cloth on a level, flat surface, place the computer on it.
5. Remove the seven screws (1) with a cross slot screwdriver and take the foot stand (2) off the computer.

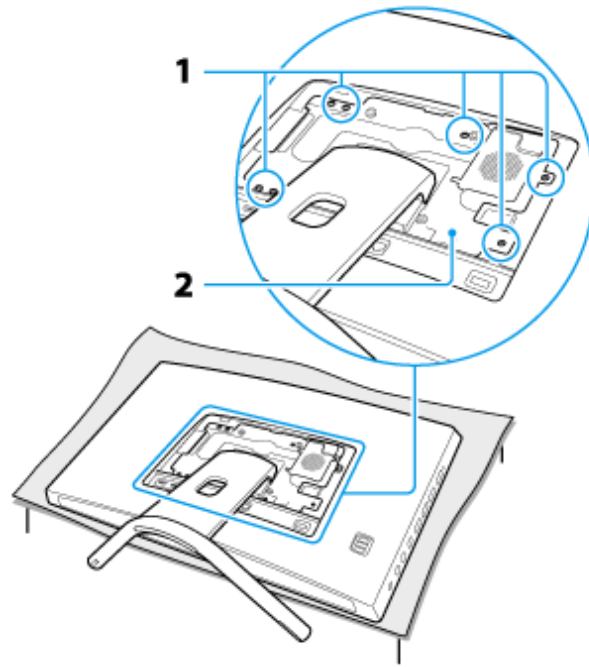

**Note**

- The foot stand is securely attached to your VAIO computer. While holding down the bottom part of the main unit, firmly grasp the foot stand and pull the stand out of the unit.

6. Remove the eight screws (3) from the back of the foot stand and take off the mounting base plate (4).

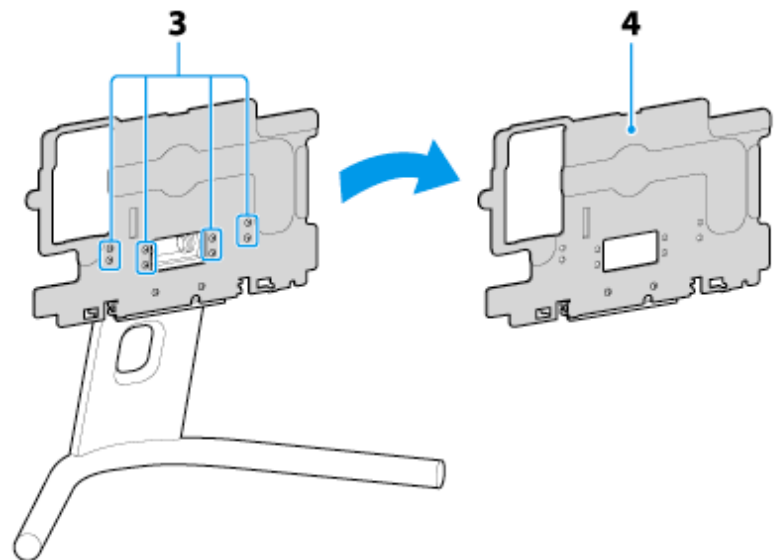

**Note**

- Be sure to keep the removed screws for future use.

7. Remove the two screws (5) from the mounting base plate (6) and take off the stand wall.

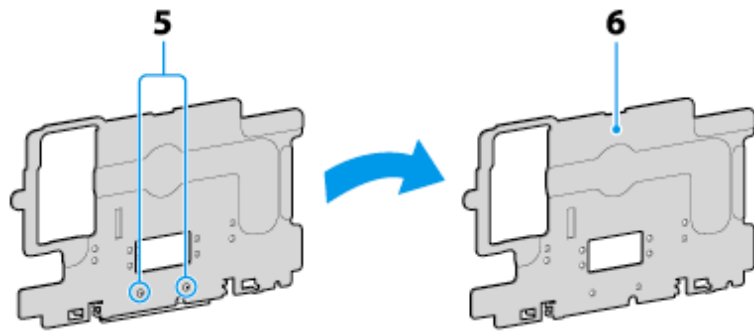

8. Flip over the mounting base plate (7) and screw it onto the back of the computer using the seven screws (8) attached at the same place in step 5.

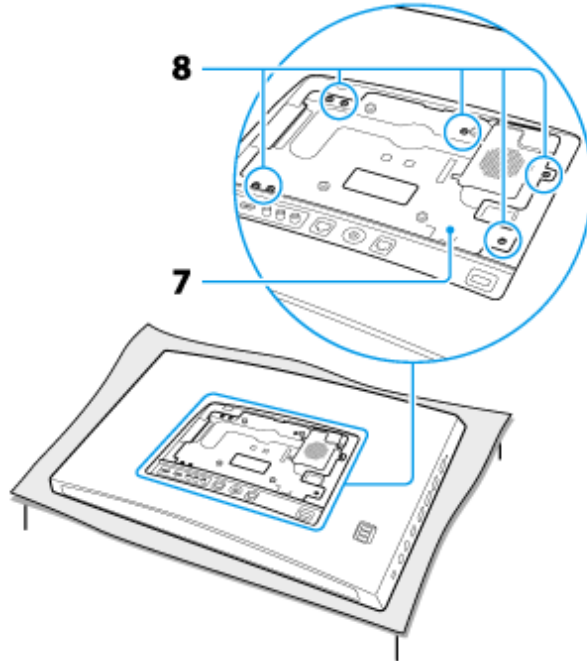

**Note**

- Be sure to tighten the screws with adequate torque.

9. Secure your wall mount bracket to the computer with four M4 screws (not supplied).

**Note**

- Do not use the screws attached to your VAIO computer.

10. Follow the instructions described in the manual that came with your mounting bracket to mount the computer.

[▶ Troubleshooting](#)**How to Use**[Parts Description](#)[Setup](#)[Network / Internet](#)[Connections](#)[Settings](#)[View](#)[Playback](#)[Backup / Recovery](#)[Security](#)[Other Operations](#)[Notifications](#)[MONITOR Function](#)

## Setting Up an Appropriate Work Environment

This topic describes where to or not to place your VAIO computer and ergonomic instructions.

### Where to place your VAIO computer

When placing your VAIO computer, ensure that:

- You have easy access to a power source and necessary ports.
- You leave enough space around the computer.
- The location is well-ventilated (such as near the window).  
Leave at least 4 inches (10 cm) of space behind and at least 8 inches (20 cm) of space on each side of the computer.
- The computer is placed on a flat surface that is wide enough and you can face the computer screen as you operate it.
- You can place the computer in front of you where you can sit upright and keep your forearms parallel to the floor.

### Where not to place your VAIO computer

Placing your VAIO computer in an inappropriate location may cause damage or a malfunction. Do not place the computer in a location subject to:

- Direct sunlight
- Magnetic items or sources
- Heat sources, such as residential heating equipment
- Excessive dust
- High humidity
- Poor ventilation

#### Note

- The area around the air exhaust vent may become extremely hot while your VAIO computer is on. Be careful before touching the area.
- Do not place any object near the air exhaust vent that may block the vent.

#### Hint

- Your VAIO computer uses high-frequency radio signals and may cause interference to radio or TV reception. If this occurs, move the computer a suitable distance away from the radio or TV.

### Ergonomic considerations

Whenever possible, you should attempt to take account of the following ergonomic considerations.

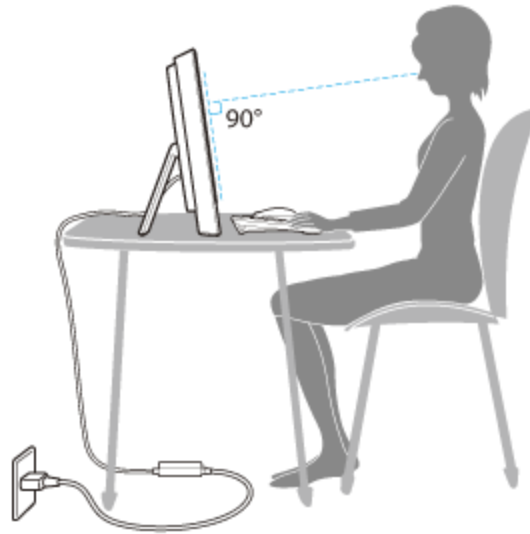

#### Furniture and posture

Sit in a chair with good back support. Adjust the level of the chair so your feet are flat on the floor. A footrest may make you more comfortable.

Sit in a relaxed, upright posture and avoid slouching forward or leaning far backwards.

#### Viewing angle of the computer screen

Use the screen tilting feature to find the best position. Make sure the computer screen is at or slightly below eye level when you are sitting in front of your VAIO computer. Adjust the brightness level of the display as well.

You can reduce eye strain and muscle fatigue by adjusting the tilt and brightness level of the computer screen to the proper position.

#### Lighting

Choose a location where windows and lights do not cause glare and reflection on the computer screen. Use indirect lighting to avoid bright spots on the computer screen. Proper lighting adds to your comfort and work efficiency.

#### Note

- While adjusting the viewing angle, do not exert excessive pressure on your VAIO computer to eliminate a risk of mechanical damage.

#### Notes on handling your VAIO computer

Observe the following to avoid malfunctions and damage to your VAIO computer.

- Place your VAIO computer gently on a flat surface to avoid a mechanical shock.



- Do not grasp the foot stand to move your VAIO computer as it may cause damage to the computer.

- Be careful not to exert pressure on the LCD screen when moving your VAIO computer.
  - Be careful not to scratch the LCD screen with your clothing or waist belt buckle when moving your VAIO computer.
  - Be sure to grasp the bottom corners of your computer screen with both hands from behind the computer when moving your VAIO computer. If not, you may lose your balance and fall down.
  - Be sure to turn off your VAIO computer before moving the computer. Moving the computer that is turned on may cause a hard disk malfunction. Be sure to disconnect all cables connected to the computer before moving it.
  - Do not drop or hit your VAIO computer. Even a slight shock or vibration may cause a hard disk malfunction.
  - Do not place your VAIO computer in an unstable position.
-

[▶ Troubleshooting](#)

## How to Use

---

[Parts Description](#)

---

---

[Setup](#)

---

---

[Network / Internet](#)

---

---

[Connections](#)

---

---

[Settings](#)

---

---

[View](#)

---

---

[Playback](#)

---

---

[Backup / Recovery](#)

---

---

[Security](#)

---

---

[Other Operations](#)

---

---

[Notifications](#)

---

---

[MONITOR Function](#)

---

## Updating Your VAIO Computer

Be sure to update your VAIO computer with the following software applications to enhance the computer's efficiency, security, and functionality.

### Note

- Your VAIO computer must be connected to the Internet to download the updates.

### Windows Update

Windows Update enables you to make your VAIO computer more stable.

1. Click  (Start), All Programs, and Windows Update.
2. Follow the on-screen instructions.

### VAIO Update

VAIO Update automatically notifies you of new updates available on the Internet, and downloads and installs them on your VAIO computer.

1. Click  (Start), All Programs, and VAIO Care.
2. After VAIO Care starts, click VAIO Software and VAIO Update.  
Follow the on-screen instructions.

---

### Related Topic

[Using VAIO Update](#)

---



[▶ Troubleshooting](#)

## How to Use

---

[Parts Description](#)

---

[Setup](#)

---

[Network / Internet](#)

---

[Connections](#)

---

[Settings](#)

---

[View](#)

---

[Playback](#)

---

[Backup / Recovery](#)

---

[Security](#)

---

[Other Operations](#)

---

[Notifications](#)

---

[MONITOR Function](#)

---

## Using VAIO Update

VAIO Update provides a service that informs you of available update information, such as important notices or update programs, to keep your VAIO computer up to date. Through the Internet, VAIO Update automatically detects the update programs that are necessary for enhancing your computer's performance or new software that is available, and let you download and install with simple steps.

1. Click  (Start), All Programs, and VAIO Care.
2. After VAIO Care starts, click VAIO Software and VAIO Update.  
Follow the on-screen instructions.

---

### Related Topic

[Keeping Your VAIO Computer in Optimum Condition \(VAIO Care\)](#)

---

▶ Troubleshooting

How to Use

Parts Description

Setup

Network / Internet

Connections

Settings

View

Playback

Backup / Recovery

Security

Other Operations

Notifications

MONITOR Function

## Using the Settings Menu (MONITOR Function)

With the settings menu, you can customize the settings such as the display and sound settings.

1. Press the HOME button on the remote, or the HOME button on the right side of your VAIO computer.

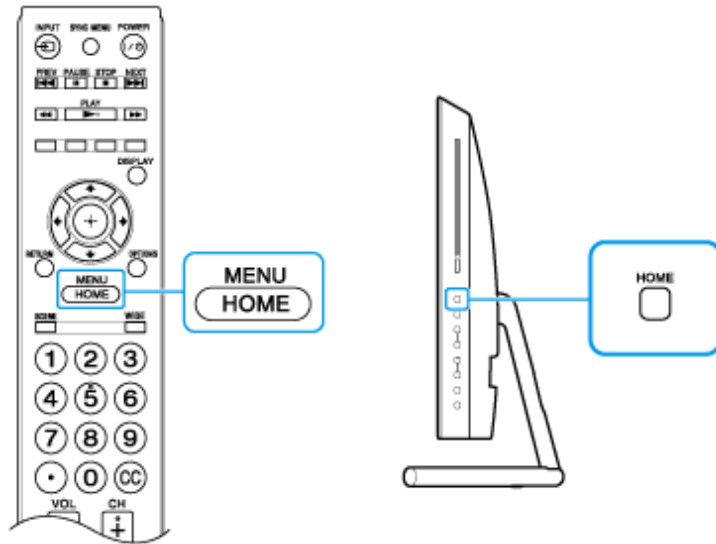

The menu screen appears.

2. Press ◀ / ▶ on the remote, or ◀ / ▶ on the right side of the computer, to select (Settings).



The settings menu appears on the right of the screen.

3. Press ▲ / ▼ on the remote, or ▲ / ▼ on the right side of the computer, to select the item you want to change.



4. Press the  button on the remote, or the INPUT/OK button on the right side of the computer.

**Note**

- You cannot use the touch screen to operate the menu screen.
-

[▶ Troubleshooting](#)

## How to Use

---

[Parts Description](#)

---

[Setup](#)

---

[Network / Internet](#)

---

[Connections](#)

---

[Settings](#)

---

[View](#)

---

[Playback](#)

---

[Backup / Recovery](#)

---

[Security](#)

---

[Other Operations](#)

---

[Notifications](#)

---

[MONITOR Function](#)

---

## Viewing the System Information

You can view the system information of your VAIO computer.

For example, after installing a memory module, you can view the information to confirm system memory changes.

1. Click  (Start), All Programs, and VAIO Control Center.
2. Click System Information and System Information.  
The system information of your VAIO computer is displayed.

---

### Related Topic

[Notes on Adding and Removing Memory Modules](#)  
[Adding and Removing Memory Modules](#)

---

[▶ Troubleshooting](#)**How to Use**[Parts Description](#)[Setup](#)[Network / Internet](#)[Connections](#)[Settings](#)[View](#)[Playback](#)[Backup / Recovery](#)[Security](#)[Other Operations](#)[Notifications](#)[MONITOR Function](#)

## Adjusting the Angle of the Screen

You can adjust the screen angle of your choice.

Pull or push the upper of the screen to adjust the angle, while holding the stand.

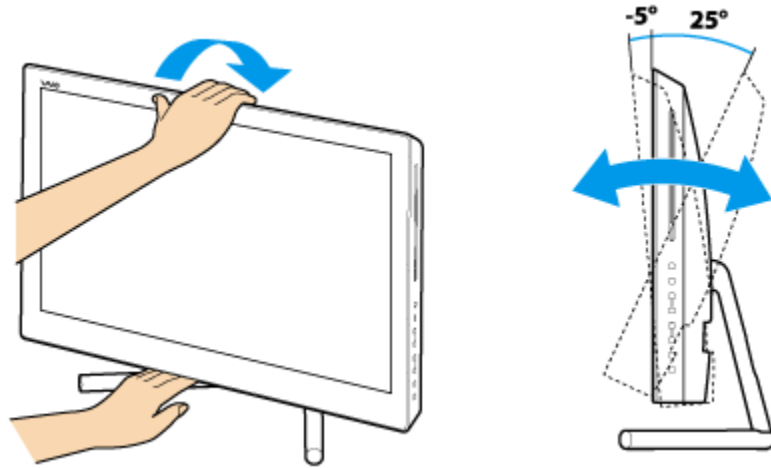

The angle of your VAIO computer can be adjusted from approximately -5 to 25 degrees.

**Note**

- Do not exert excessive pressure on your VAIO computer while adjusting the angle of the screen, as damage may result.

[▶ Troubleshooting](#)

## How to Use

---

[Parts Description](#)

---

[Setup](#)

---

[Network / Internet](#)

---

[Connections](#)

---

[Settings](#)

---

[View](#)

---

[Playback](#)

---

[Backup / Recovery](#)

---

[Security](#)

---

[Other Operations](#)

---

[Notifications](#)

---

[MONITOR Function](#)

---

## About Pro Picture Setup / Video Input Settings (MONITOR Function)

This topic explains the advanced- picture settings.

This setting allows you to use the following features.

- Produces natural color by changing the luminance tone reproduction of HDMI input color signals.
- Creates gradations using Super Bit Mapping technology.

---

### Related Topic

[Displaying the Menu Screen \(MONITOR Function\)](#)

---

[▶ Troubleshooting](#)**How to Use**

---

[Parts Description](#)

---

[Setup](#)

---

[Network / Internet](#)

---

[Connections](#)

---

[Settings](#)

---

[View](#)

---

[Playback](#)

---

[Backup / Recovery](#)

---

[Security](#)

---

[Other Operations](#)

---

[Notifications](#)

---

[MONITOR Function](#)

---

## About the Auto Shut-off Settings (MONITOR Function) <TV tuner board installed models>

Turns the TV off when no input signal is detected for 15 minutes.

---

### Related Topic

[Displaying the Menu Screen \(MONITOR Function\)](#)

---

[▶ Troubleshooting](#)**How to Use**

---

[Parts Description](#)

---

[Setup](#)

---

[Network / Internet](#)

---

[Connections](#)

---

[Settings](#)

---

[View](#)

---

[Playback](#)

---

[Backup / Recovery](#)

---

[Security](#)

---

[Other Operations](#)

---

[Notifications](#)

---

[MONITOR Function](#)

---

## About the Closed Captions (CC) Settings (MONITOR Function) <TV tuner board installed models>

This setting allows you to select from several closed caption modes.  
You can turn on or off the closed caption, and adjust the closed caption display.

---

### Related Topic

[Displaying the Menu Screen \(MONITOR Function\)](#)

---



[▶ Troubleshooting](#)**How to Use**

---

[Parts Description](#)

---

[Setup](#)

---

[Network / Internet](#)

---

[Connections](#)

---

[Settings](#)

---

[View](#)

---

[Playback](#)

---

[Backup / Recovery](#)

---

[Security](#)

---

[Other Operations](#)

---

[Notifications](#)

---

[MONITOR Function](#)

---

## About the Info Banner Settings (MONITOR Function) <TV tuner board installed models>

Sets the amount of information to display about the currently viewed TV channel and program.

---

### Related Topic

[Displaying the Menu Screen \(MONITOR Function\)](#)

---

[▶ Troubleshooting](#)

## How to Use

---

[Parts Description](#)

---

[Setup](#)

---

[Network / Internet](#)

---

[Connections](#)

---

[Settings](#)

---

[View](#)

---

[Playback](#)

---

[Backup / Recovery](#)

---

[Security](#)

---

[Other Operations](#)

---

[Notifications](#)

---

[MONITOR Function](#)

---

## About the Language Settings (MONITOR Function)

Sets the language displayed on the menu screens.

---

Related Topic

[Displaying the Menu Screen \(MONITOR Function\)](#)

---

[▶ Troubleshooting](#)

## How to Use

---

[Parts Description](#)

---

[Setup](#)

---

[Network / Internet](#)

---

[Connections](#)

---

[Settings](#)

---

[View](#)

---

[Playback](#)

---

[Backup / Recovery](#)

---

[Security](#)

---

[Other Operations](#)

---

[Notifications](#)

---

[MONITOR Function](#)

---

## About the Picture Adjustments / Picture Settings (MONITOR Function)

This topic explains picture adjustments (for input sources other than PC).

This setting allows to you use the following functions/features.

- Changes the picture mode for the input source.
- Adjusts the brightness and contrast of the picture.
- Adjusts picture colors.
- Reduces picture noise and motion blur.

### Hint

- By pressing the OPTIONS button on the remote, or the OPTION button on the right side of your VAIO computer during playback, you can change settings without selecting  (Settings).

---

### Related Topic

[Displaying the Menu Screen \(MONITOR Function\)](#)

---

[▶ Troubleshooting](#)

## How to Use

---

[Parts Description](#)

---

[Setup](#)

---

[Network / Internet](#)

---

[Connections](#)

---

[Settings](#)

---

[View](#)

---

[Playback](#)

---

[Backup / Recovery](#)

---

[Security](#)

---

[Other Operations](#)

---

[Notifications](#)

---

[MONITOR Function](#)

---

## About the Scene Select Settings (MONITOR Function)

This setting allows you to optimize picture and sound quality according to the input source. You can utilize this function automatically, or select each function item manually.

### Hint

- By pressing the OPTIONS button on the remote, or the OPTION button on the right side of your VAIO computer during playback, you can change settings without selecting  (Settings).

---

### Related Topic

[Displaying the Menu Screen \(MONITOR Function\)](#)

---

[▶ Troubleshooting](#)

## How to Use

---

[Parts Description](#)

---

[Setup](#)

---

[Network / Internet](#)

---

[Connections](#)

---

[Settings](#)

---

[View](#)

---

[Playback](#)

---

[Backup / Recovery](#)

---

[Security](#)

---

[Other Operations](#)

---

[Notifications](#)

---

[MONITOR Function](#)

---

## About the Screen Settings (MONITOR Function)

This topic explains screen settings.

This setting allows you to use the following functions/features.

- Switches the display area.
- Adjusts the vertical position and horizontal position of the picture.

Hint

- The above functions are available for all inputs other than PC.

---

Related Topic

[Displaying the Menu Screen \(MONITOR Function\)](#)

---

[▶ Troubleshooting](#)**How to Use**[Parts Description](#)[Setup](#)[Network / Internet](#)[Connections](#)[Settings](#)[View](#)[Playback](#)[Backup / Recovery](#)[Security](#)[Other Operations](#)[Notifications](#)[MONITOR Function](#)

## About the Touch Screen <Touch screen equipped models>

The touch screen enables direct interaction with the VAIO computer using your finger(s). You can perform various gestures on the touch screen instead of mouse operations, such as selecting items and scrolling.

Your VAIO computer supports multi-touch input.

**Note**

- Your VAIO computer is equipped with a capacitive touch screen. When using it, note the following characteristics of the capacitive touch screen.
  - The touch screen will not work if you touch it with fingernails, or if you wear gloves.
  - To repeat tapping, be sure to lift your finger at least 1/6 inch / 4 mm off the touch screen after each tap.
    - If you do not lift your finger enough, your repeated tap may not be recognized.
  - If tapping triggers an unintentional operation, make sure that no other parts of your body, including your clothes, are in contact with the touch screen.
  - Depending on the spot you touch on the screen, the touch screen sensitivity varies. This is normal and does not indicate a malfunction.
  - The surface of the touch screen may get hot. This is normal and does not indicate a malfunction.
  - Even though the surface of the touch screen is tempered glass, it could still become damaged. Treat it with adequate care. If it breaks, small granular shards may scatter and cause injury.
    - Do not drop the touch screen or subject it to a strong impact. Do not scratch the surface. A surface flaw may cause the glass to break.
  - A protection sheet is attached to the LCD screen frame at the factory. Remove the sheet before use; otherwise the touch screen may not work correctly.
  - Some software does not accept touch screen operations.

**Related Topic**

[How to Use the Touch Screen<Touch screen equipped models>](#)

[▶ Troubleshooting](#)

## How to Use

---

[Parts Description](#)

---

[Setup](#)

---

[Network / Internet](#)

---

[Connections](#)

---

[Settings](#)

---

[View](#)

---

[Playback](#)

---

[Backup / Recovery](#)

---

[Security](#)

---

[Other Operations](#)

---

[Notifications](#)

---

[MONITOR Function](#)

---

## Changing the LCD Brightness

You can adjust the LCD brightness.

### Hint

- Follow these steps to change the LCD brightness for the PC.  
To change the LCD brightness when you are using the function available without running the PC, such as the HDMI/VIDEO function, see [About the Picture Adjustments / Picture Settings](#). [\[Details\]](#)
- 1. Press the Fn+F5 key or Fn+F6 keys.  
To decrease lighting intensity, keep pressing the Fn+F5 keys. To increase lighting intensity, keep pressing the Fn+F6 keys.  
When you press the keys, the brightness indicator is displayed for a few seconds.

### Hint

- The LCD brightness setting is retained even after your VAIO computer is turned off and restarted.

---

### Related Topic

[Combinations and Functions with the Fn Key](#)

---

[▶ Troubleshooting](#)

## How to Use

---

[Parts Description](#)

---

[Setup](#)

---

[Network / Internet](#)

---

[Connections](#)

---

[Settings](#)

---

[View](#)

---

[Playback](#)

---

[Backup / Recovery](#)

---

[Security](#)

---

[Other Operations](#)

---

[Notifications](#)

---

[MONITOR Function](#)

---

## Changing the Resolution (Size) of the Screen Image

You can change the screen resolution to adjust the size of the characters and images on the computer screen.

Refer to Windows Help and Support for more information.

1. Right-click on the desktop and select Screen resolution.
2. Click the current screen resolution next to Resolution and move the slider to change the screen resolution.

### Note

- You may not be able to play high-resolution videos depending on the amount of video memory on your VAIO computer. In such a case, lower the screen resolution.
- Do not change the display resolution while using video/image software or playing DVDs, as it may cause unsuccessful playback/display or unstable system operations.

---

### Related Topic

[Connecting a TV with an HDMI Input Port](#)  
[Notes on the LCD screen](#)

---



[▶ Troubleshooting](#)

## How to Use

---

[Parts Description](#)

---

[Setup](#)

---

[Network / Internet](#)

---

[Connections](#)

---

[Settings](#)

---

[View](#)

---

[Playback](#)

---

[Backup / Recovery](#)

---

[Security](#)

---

[Other Operations](#)

---

[Notifications](#)

---

[MONITOR Function](#)

---

## Changing the Resolution (Size) of the Screen Image on an HDMI-Connected Device

You can change the screen resolution or size of your VAIO computer's screen image displayed on an external display, such as a TV, connected to the computer with an HDMI cable (not supplied).

1. Connect your VAIO computer to an HDMI equipped TV with an HDMI cable. [\[Details\]](#)
2. Turn on the TV.
3. Double-click  (HDMI Resolution Settings) in the desktop notification area. The settings window appears.
4. Click the Select Resolution tab to select the desired resolution, and then click Apply. After a few seconds, the selected resolution is applied.
5. If the computer image does not fit the displayable region of the TV, click the Adjust Resolution tab to adjust the display size.

### Note

- Some resolution options may not be available, depending on the model or the HDMI-connected device.
- The function to adjust the screen resolution may be disabled depending on the selected resolution.

---

### Related Topic

[Connecting a TV with an HDMI Input Port](#)[Selecting Display Modes](#)

---

[▶ Troubleshooting](#)**How to Use**[Parts Description](#)[Setup](#)[Network / Internet](#)[Connections](#)[Settings](#)[View](#)[Playback](#)[Backup / Recovery](#)[Security](#)[Other Operations](#)[Notifications](#)[MONITOR Function](#)

## Connecting a TV with an HDMI Input Port

You can connect a TV with an HDMI input port to your VAIO computer with an HDMI cable (not supplied).

Refer to the manual that came with your TV for more information on installation and use.

1. Plug the power cord of your TV into an AC outlet.
2. Connect one end of an HDMI cable to the HDMI output port [\[Details\]](#) on your VAIO computer and the other end to the TV.
3. Set the TV input to the external input.

The screen image of your VAIO computer is displayed on the TV.

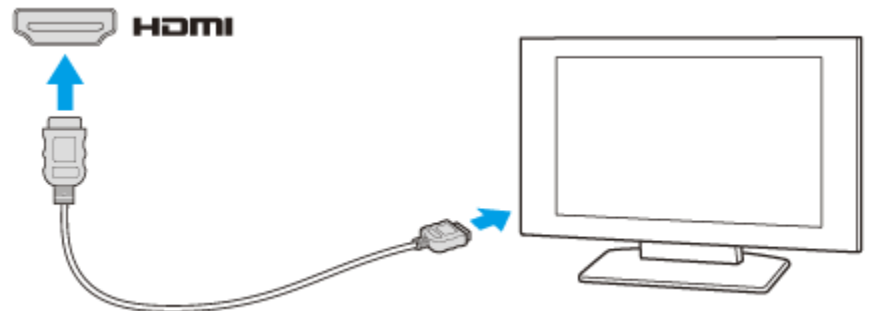
**Note**

- If a device driver other than the one provided by Sony is used, the image will not be displayed and audio will not be heard. Always use the device driver provided by Sony for updates.
- To hear sound from a device connected to the HDMI output port, you need to change the sound output device. For detailed instructions, see [Changing the Sound Output Device](#). [\[Details\]](#)

**Hint**

- Your VAIO computer is compliant with the High-bandwidth Digital Content Protection (HDCP) standard and capable of encrypting the transmission channel of digital video signals for the purpose of copyright protection, which enables you to view a wide variety of copyright protected and high-quality content.

**Related Topic**[Selecting Display Modes](#)[Using the Multiple Monitors Function](#)[Changing the Resolution \(Size\) of the Screen Image](#)[Changing the Resolution \(Size\) of the Screen Image on an HDMI-Connected Device](#)

[▶ Troubleshooting](#)**How to Use**[Parts Description](#)[Setup](#)[Network / Internet](#)[Connections](#)[Settings](#)[View](#)[Playback](#)[Backup / Recovery](#)[Security](#)[Other Operations](#)[Notifications](#)[MONITOR Function](#)

## Displaying Two Pictures on the Screen Simultaneously (PIP) <TV tuner board installed models>

This feature lets you watch two pictures on the screen simultaneously.

You can fill the screen with a picture from one input source and display in an inset window a picture from another input source.

1. Press the OPTIONS button on the remote.

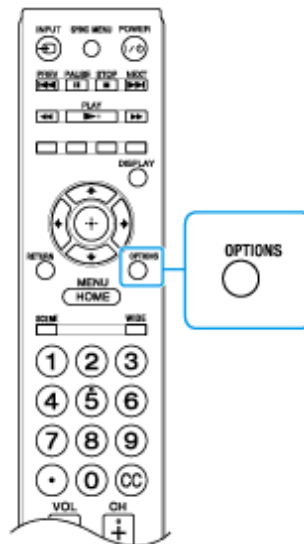

2. Select Twin Picture and PIP.



3. Press ◀ / ▶ on the remote to switch audio output between the two pictures.

### To move the inset window

1. Press ▲ / ▼ on the remote.

**Note**

- A PC input picture and an HDMI input picture cannot be displayed simultaneously.
- The menu screen (displayed by pressing the HOME button) cannot be displayed simultaneously with another screen.

[Related Topic](#)



[▶ Troubleshooting](#)**How to Use**[Parts Description](#)[Setup](#)[Network / Internet](#)[Connections](#)[Settings](#)[View](#)[Playback](#)[Backup / Recovery](#)[Security](#)[Other Operations](#)[Notifications](#)[MONITOR Function](#)

## Displaying Two Pictures side-by-side on the Screen (P&P) <TV tuner board installed models>

This feature lets you watch two pictures on the screen side-by-side.

1. Press the OPTIONS button on the remote.

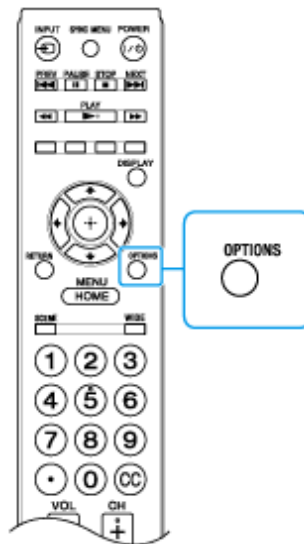

2. Select Twin Picture and P&P.



3. Press ◀ / ▶ on the remote to switch between the audio output of the two pictures.  
The audio output will correspond to the picture that is highlighted.

### To change the picture size

1. Press ◀ / ▶ on the remote to select a picture.
2. Press ▲ / ▼ on the remote repeatedly to select the size you want.

**Note**

- A PC input picture and an HDMI input picture cannot be displayed simultaneously.
- The menu screen (displayed by pressing the HOME button) cannot be displayed simultaneously with another screen.

[Related Topic](#)



[▶ Troubleshooting](#)

## How to Use

---

[Parts Description](#)

---

[Setup](#)

---

[Network / Internet](#)

---

[Connections](#)

---

[Settings](#)

---

[View](#)

---

[Playback](#)

---

[Backup / Recovery](#)

---

[Security](#)

---

[Other Operations](#)

---

[Notifications](#)

---

[MONITOR Function](#)

---

## Enable/Disable the Touch Screen <Touch screen equipped models>

By default, the touch screen of the VAIO computer is enabled. To disable/enable the touch screen, do the following:

1. Click  (Start) and Control Panel.
2. Click Hardware and Sound and Pen and Touch.
3. Click the Touch tab.
4. Click to select/clear the Use your finger as an input device check box.  
Checked: The touch screen is enabled.  
Unchecked: The touch screen is disabled.
5. Click OK.

---

### Related Topic

[How to Use the Touch Screen<Touch screen equipped models>](#)

---

[▶ Troubleshooting](#)**How to Use**[Parts Description](#)[Setup](#)[Network / Internet](#)[Connections](#)[Settings](#)[View](#)[Playback](#)[Backup / Recovery](#)[Security](#)[Other Operations](#)[Notifications](#)[MONITOR Function](#)

## Enjoying Sounds Only (Picture Off)

This feature lets you enjoy sound only with the LCD screen turned off.

1. Press the **OPTIONS** button on the remote, or the **OPTION** button on the right side of your VAIO computer.

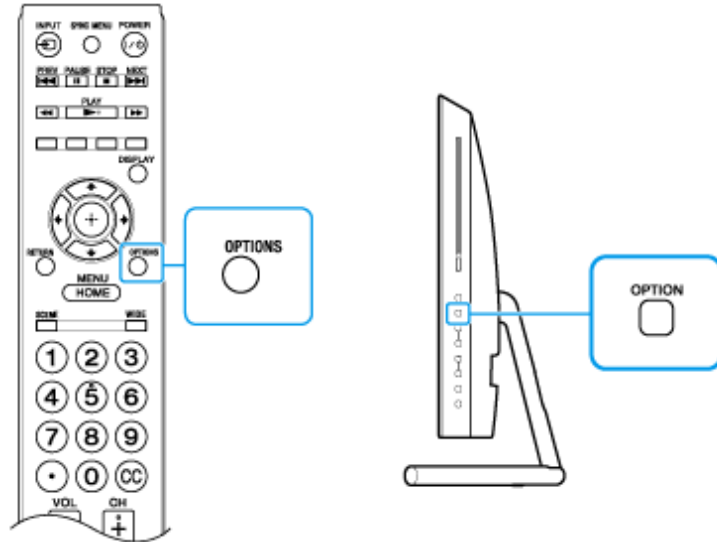

2. Select **Picture Off**.

To turn on the LCD screen again

Press any button on the remote or on the right side of your VAIO computer.

Related Topic

[Turning Off the LCD Screen](#)



[▶ Troubleshooting](#)

## How to Use

---

[Parts Description](#)

---

[Setup](#)

---

[Network / Internet](#)

---

[Connections](#)

---

[Settings](#)

---

[View](#)

---

[Playback](#)

---

[Backup / Recovery](#)

---

[Security](#)

---

[Other Operations](#)

---

[Notifications](#)

---

[MONITOR Function](#)

---

## Enlarging the Text Size (DPI) <Touch screen equipped models>

You can change the DPI to enlarge the font size, making it easier to touch specific text.

1. Click  (Start) and Control Panel.
2. Click Customize Desktop.
3. Click Make text and other items larger or smaller.
4. Select the desired settings for the options on the screen, and then click Apply.
5. If a message appears and recommends logging off, click Log off now.
6. Log on again.  
The text font size for Windows changes.

### Hint

- You can click Set custom text size (DPI) on the left of the Display window to set the text size more easily.
-

[▶ Troubleshooting](#)**How to Use**[Parts Description](#)[Setup](#)[Network / Internet](#)[Connections](#)[Settings](#)[View](#)[Playback](#)[Backup / Recovery](#)[Security](#)[Other Operations](#)[Notifications](#)[MONITOR Function](#)

## How to Use the Touch Screen <Touch screen equipped models>

You can tap the touch screen or make a simple motion with your fingers to operate the VAIO computer.

### Basic operations

To click (tap)

Tap on the touch screen once with a finger. You can select a button, such as OK and Cancel, or an item in a menu by tapping it.

To double click (double tap)

Tap on the touch screen twice in quick succession with a finger. You can start software, such as a word processor or a spreadsheet program, or open a file by double-tapping its icon.

To right click

Touch and hold the desired point on the touch screen and wait until a  animation appears, and then lift your finger off the screen.

Various pop-up menus appear, depending on the item clicked.

To drag

Put a finger on the touch screen and slide it while keeping the finger in contact with the screen. You can move a file or change the window size.

To drag and drop

Touch the desired file icon, slide to another folder, window or software icon, and then lift your finger off the screen. You can move or copy a file.

### Note

- The touch screen cannot be used when using an input state other than PC such as HDMI/VIDEO input function.

### Advanced operations

You can make a simple motion (gesture) with your fingers on the touch screen to operate your VAIO computer.

The response to a gesture varies depending on the software.

This section describes the operations for Internet Explorer and Windows Photo Viewer.

To scroll

Touch and slide a scrollable area of a window, such as an Internet Explorer window. You can also drag the slider on the vertical scroll bar of the selected window to scroll it.

To zoom-in/zoom-out on an image such as a photo (zoom)

Pinch on the touch screen with two fingers for zooming on an image, such as a photo on Windows Photo Viewer. Pinch open to zoom in or pinch close to zoom out.

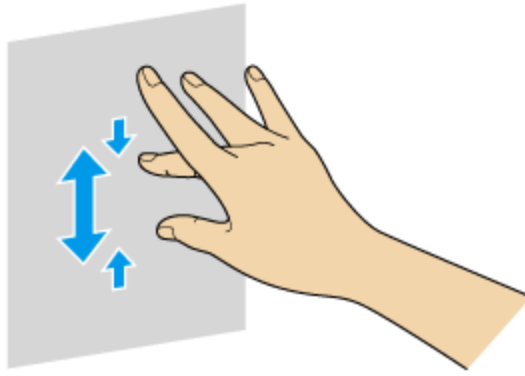

To rotate an image such as a photo (rotate)

Put two fingers on the touch screen and slide them in circles to rotate the underlying object, such as a photo on Windows Photo Viewer.

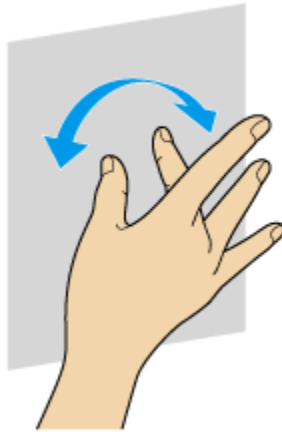

To flick

Put a finger on the touch screen and slide it quickly in a straight line. The response by your VAIO computer is determined by the direction of the flick. There are four default responses: flick left moves forward, flick right moves backward, flick up scrolls up, and flick down scrolls down.

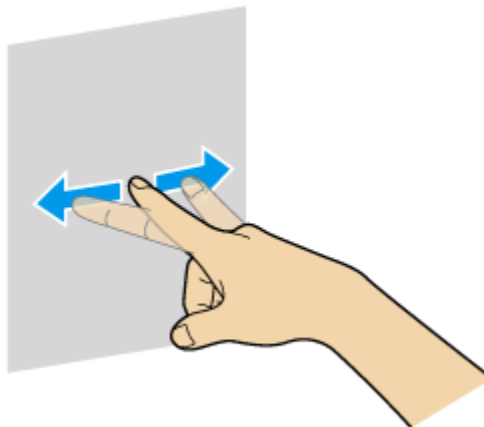

**Note**

- The touch screen cannot be used when using an input state other than PC such as HDMI/VIDEO input function.

---

Related Topic



[▶ Troubleshooting](#)

## How to Use

---

[Parts Description](#)

---

[Setup](#)

---

[Network / Internet](#)

---

[Connections](#)

---

[Settings](#)

---

[View](#)

---

[Playback](#)

---

[Backup / Recovery](#)

---

[Security](#)

---

[Other Operations](#)

---

[Notifications](#)

---

[MONITOR Function](#)

---

## Multiple Touch Screen Operation

In the VAIO Touch Portal, you can choose a wide variety of software that can be enjoyed with touch screen operation.

1. Tap the  VAIO Touch Portal button in the lower right corner of the screen.  
The VAIO Touch Portal will start.

### Note

- The touch screen cannot be used when using an input state other than PC such as HDMI/VIDEO input function.
-

[▶ Troubleshooting](#)

## How to Use

---

[Parts Description](#)

---

[Setup](#)

---

[Network / Internet](#)

---

[Connections](#)

---

[Settings](#)

---

[View](#)

---

[Playback](#)

---

[Backup / Recovery](#)

---

[Security](#)

---

[Other Operations](#)

---

[Notifications](#)

---

[MONITOR Function](#)

---

## Notes on Using the Touch Screen <Touch screen equipped models>

Before using the touch screen, read the following precautions for correct use.

- Do not push the touch screen roughly.  
Gentle touches always work. The degree of pressing force does not count for operations as your VAIO computer is equipped with a capacitive touch screen.
  - Do not use an object other than your finger to use the touch screen.  
The touch screen may be damaged or a malfunction may occur. Be sure to touch only with your finger.
  - Keep the touch screen clean for good touch sensitivity. Dirt may cause damage or a malfunction.
-

[▶ Troubleshooting](#)

## How to Use

---

[Parts Description](#)

---

[Setup](#)

---

[Network / Internet](#)

---

[Connections](#)

---

[Settings](#)

---

[View](#)

---

[Playback](#)

---

[Backup / Recovery](#)

---

[Security](#)

---

[Other Operations](#)

---

[Notifications](#)

---

[MONITOR Function](#)

---

## Notes on the LCD screen

Read the following precautions for correct use of the LCD screen.

- The LCD screen is manufactured using high-precision technology. You may, however, see tiny black points and/or bright points (red, blue, or green) that continuously appear on the LCD screen. This is a normal result of the manufacturing process and does not indicate a malfunction.
- Do not scratch the surface of the LCD screen or exert pressure on it. This could cause damage.
- The LCD screen may become warm during operation. This is normal and does not indicate a malfunction.
- Due to the mechanical design of your VAIO computer's LCD screen/touch screen, the screen surface may become warm while you are using the computer for an extended period of time. This is normal and does not indicate a malfunction. (Touch screen equipped models)
- The LCD screen/touch screen is made of reinforced glass to implement high durability, however, treat the screen with care as it is not 100% unbreakable. In case the screen breaks into small pieces, be careful not to cut yourself on the pieces of broken glass. (Touch screen equipped models)
- Do not leave the LCD screen facing the sun. This could damage the LCD screen. Be sure to block direct sunlight when using your VAIO computer near a window.
- Using your VAIO computer in low temperature conditions may produce a residual image on the LCD screen. This does not indicate a malfunction. When the computer returns to normal temperature, the screen returns to normal.
- A residual image may appear on the LCD screen if the same image is displayed for an extended period of time. The residual image disappears after a while. You can use a screen saver to prevent residual images.

[▶ Troubleshooting](#)

## How to Use

---

[Parts Description](#)

---

---

[Setup](#)

---

---

[Network / Internet](#)

---

---

[Connections](#)

---

---

[Settings](#)

---

---

[View](#)

---

---

[Playback](#)

---

---

[Backup / Recovery](#)

---

---

[Security](#)

---

---

[Other Operations](#)

---

---

[Notifications](#)

---

---

[MONITOR Function](#)

---

## Selecting Display Modes

You can switch the display output between the computer screen and an external display connected to your VAIO computer.

1. Turn on an external display.
2. Press the P key several times while holding down the Windows key to select your desired display output, and then press the Enter key.

### Note

- If you disconnect a display cable (not supplied) while only an external display is selected as the display output, it is hard to operate your VAIO computer because the computer screen is blank.  
To switch the display output to the computer screen, press the P key twice while holding down the Windows key, and then press the Enter key.
- The display switch may become unavailable or your VAIO computer may become unstable during video playback. Exit the video playback software before switching the display output.
- The display switch may not be available depending on the type of external display or projector.

---

### Related Topic

[Using the Multiple Monitors Function](#)

[Connecting a TV with an HDMI Input Port](#)

---



[▶ Troubleshooting](#)

## How to Use

[Parts Description](#)[Setup](#)[Network / Internet](#)[Connections](#)[Settings](#)[View](#)[Playback](#)[Backup / Recovery](#)[Security](#)[Other Operations](#)[Notifications](#)[MONITOR Function](#)

## Turning Off the LCD Screen

You can turn off the LCD screen and LCD backlight.

1. Press the MONITOR power button.

The LCD screen and LCD backlight turn off, and the MONITOR indicator lights in green.

### Note

- Playback of a movie might stop if you turn off the monitor by pressing the MONITOR power button.

### Hint

- There will be no sound and nothing will be displayed on the LCD screen if you turn off the monitor by pressing the MONITOR power button. To turn off only the LCD screen, use the Picture Off function. [\[Details\]](#)
- You can press the MONITOR power button to turn off the TV (TV tuner board installed models).

## Turn on the LCD screen

If you press the MONITOR power button again, the previous input state will appear. The MONITOR indicator lights in green.

### Related Topic

[Watching TV with Your VAIO Computer<TV tuner board installed models>  
Enjoying Sounds Only \(Picture Off\)](#)

[▶ Troubleshooting](#)

## How to Use

[Parts Description](#)[Setup](#)[Network / Internet](#)[Connections](#)[Settings](#)[View](#)[Playback](#)[Backup / Recovery](#)[Security](#)[Other Operations](#)[Notifications](#)[MONITOR Function](#)

## Using the Multiple Monitors Function

The Multiple Monitors function allows you to distribute portions of your desktop across separate displays.

For example, if you have an external display connected to the monitor port, the computer screen and the external display can function as a single desktop.

1. Right-click on the desktop and select Screen resolution.
2. Click the drop-down list next to Multiple Displays, select Extend these displays, and click OK.  
The setting options vary depending on the number of the connected external displays.

### Note

- If you set different colors on each display, do not expand a single window across two displays, or your software may not work properly.
- Your external display may not support the Multiple Monitors function.
- Certain software applications may not be compatible with the Multiple Monitors settings.
- High screen resolution and high color depth may not be displayed correctly. Set fewer colors or a lower resolution for each display.
- Do not change the display settings while using video/image software or playing DVDs, as it may cause unsuccessful playback/display or unstable system operations. Change the display settings after you exit the video/image software.

### Hint

- You can set the screen resolution for each display used for the Multiple Monitors function.

### Related Topic

[Changing the Resolution \(Size\) of the Screen Image](#)[Selecting Display Modes](#)[Connecting a TV with an HDMI Input Port](#)

[▶ Troubleshooting](#)**How to Use**[Parts Description](#)[Setup](#)[Network / Internet](#)[Connections](#)[Settings](#)[View](#)[Playback](#)[Backup / Recovery](#)[Security](#)[Other Operations](#)[Notifications](#)[MONITOR Function](#)

## Connecting a Power Source

Connect your VAIO computer to an AC power source. Carefully read the precautions in [Notes on Using the Power Source](#) before connection. [\[Details\]](#)

1. Plug one end of the power cord (1) into the AC adapter (3).
2. Plug the other end of the power cord into an AC outlet (2).
3. Plug the cable from the AC adapter (3) into the DC IN port (4) on your VAIO computer.

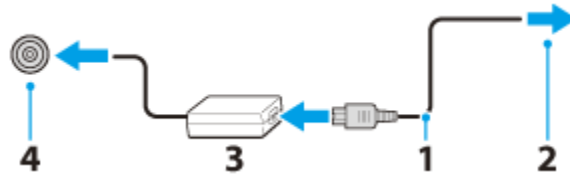
**Note**

- Do not plug more than one device into the same AC outlet.
- The shape of the AC adapter varies depending on the model you purchased.
- Make sure that the power plug is firmly plugged into your VAIO computer.

**Hint**

- You can purchase a power strip with a surge protector to help prevent damage to your VAIO computer caused by sudden power surges (in an electrical storm, for example).

**Related Topic**[Turning on Your VAIO Computer](#)[Shutting Down Your VAIO Computer](#)[Notes on Using the Power Source](#)

[▶ Troubleshooting](#)

## How to Use

[Parts Description](#)[Setup](#)[Network / Internet](#)[Connections](#)[Settings](#)[View](#)[Playback](#)[Backup / Recovery](#)[Security](#)[Other Operations](#)[Notifications](#)[MONITOR Function](#)

## Shutting Down Your VAIO Computer

Shut down your VAIO computer properly to avoid losing unsaved data.

1. Turn off any peripherals connected to your VAIO computer.
2. Save your data and close all running software applications.
3. Click  (Start) and the Shut down button.

After a short time, your VAIO computer automatically turns off and the green power indicator light turns off.

### Note

- An improper shutdown may cause loss of unsaved data or your VAIO computer to malfunction.
- After shutting down your VAIO computer, wait at least 30 seconds before turning it on again.
- To disconnect your VAIO computer completely from an AC power source, turn off the computer and unplug the power cord from the AC outlet.

### Related Topic

[Turning on Your VAIO Computer](#)[Restarting Your VAIO Computer](#)[Using Sleep Mode](#)[Notes on Using the Power Source](#)

[▶ Troubleshooting](#)

## How to Use

---

[Parts Description](#)

---

---

[Setup](#)

---

---

[Network / Internet](#)

---

---

[Connections](#)

---

---

[Settings](#)

---

---

[View](#)

---

---

[Playback](#)

---

---

[Backup / Recovery](#)

---

---

[Security](#)

---

---

[Other Operations](#)

---

---

[Notifications](#)

---

---

[MONITOR Function](#)



---

## Turning on Your VAIO Computer

Turn on your VAIO computer to start Windows. Carefully read the precautions in Notes on Using the Power Source before turning on. [\[Details\]](#)

1. Plug your VAIO computer into an AC outlet. [\[Details\]](#)
2. Press and hold down the  (Power) button until the power indicator light turns on in green.  
Your VAIO computer is turned on, and Windows starts after a while.

### Note

- If you press and hold down the  (Power) button for more than four seconds, your VAIO computer will not turn on.  
Press the  (Power) button lightly, and release it immediately when the power indicator light turns on.

### Hint

- By default, your VAIO computer automatically enters Sleep mode after a certain period of inactivity while the computer is connected to an AC outlet. [\[Details\]](#)

---

### Related Topic

[Connecting a Power Source](#)  
[Shutting Down Your VAIO Computer](#)  
[Restarting Your VAIO Computer](#)  
[Notes on Using the Power Source](#)

---

[▶ Troubleshooting](#)**How to Use**

---

[Parts Description](#)

---

---

[Setup](#)

---

---

[Network / Internet](#)

---

---

[Connections](#)

---

---

[Settings](#)

---

---

[View](#)

---

---

[Playback](#)

---

---

[Backup / Recovery](#)

---

---

[Security](#)

---

---

[Other Operations](#)

---

---

[Notifications](#)

---

---

[MONITOR Function](#)

---

## Notes on Sleep Mode

Read the following precautions before using Sleep mode.

- Some software applications may not support Sleep mode. When running such applications, exit them before placing your VAIO computer into Sleep mode.
- Some USB devices may not support Sleep mode. When your VAIO computer resumes from Sleep mode, the computer may not recognize such USB devices, depending on the type and number of connected USB devices.  
If you cannot place the computer into Sleep mode, disconnect all USB devices before placing the computer into Sleep mode.
- If your VAIO computer enters Sleep mode when Windows or the computer is unstable, it may not resume from Sleep mode. The following operations are recommended:
  - Before placing your VAIO computer into Sleep mode, save your files and close running software.
  - Shut down your VAIO computer periodically.
- Depending on the condition of Windows, your VAIO computer cannot enter Sleep mode.
- If your VAIO computer is equipped with a TV tuner, the computer cannot enter Sleep mode while:
  - Recording.
  - Preparing for a scheduled recording, for example just before the scheduled recording starts.
  - Receiving remote scheduled recording information (when the remote scheduled recording function is activated).
- If your VAIO computer enters Sleep mode while running a task, such as DVD writing, the task may be suspended.

---

**Related Topic**[Using Sleep Mode](#)[Notes on Using the Power Source](#)

---

[▶ Troubleshooting](#)

## How to Use

---

[Parts Description](#)

---

[Setup](#)

---

[Network / Internet](#)

---

[Connections](#)

---

[Settings](#)

---

[View](#)

---

[Playback](#)

---

[Backup / Recovery](#)

---

[Security](#)

---

[Other Operations](#)

---

[Notifications](#)

---

[MONITOR Function](#)

---

## Notes on Using the Power Source

Read the following precautions before plugging your VAIO computer into an AC power source.

- If you unplug your VAIO computer from an AC power source while the computer is turned on or in Sleep mode, you will lose all unsaved data.

### Notes on the AC adapter

- Use the AC adapter supplied with your VAIO computer or genuine Sony products. Do not use any other AC adapter as it may cause a malfunction.
- Do not connect the AC adapter to a power conversion device such as a travel power converter. It may cause overheating or a malfunction.
- If the AC adapter cable becomes damaged or broken, do not use it.

---

### Related Topic

[Connecting a Power Source](#)[Turning on Your VAIO Computer](#)[Shutting Down Your VAIO Computer](#)[Restarting Your VAIO Computer](#)

---

[▶ Troubleshooting](#)

## How to Use

---

[Parts Description](#)

---

[Setup](#)

---

[Network / Internet](#)

---

[Connections](#)

---

[Settings](#)

---

[View](#)

---

[Playback](#)

---

[Backup / Recovery](#)

---

[Security](#)

---

[Other Operations](#)

---

[Notifications](#)



---

[MONITOR Function](#)

---

## Restarting Your VAIO Computer

After changing the settings or installing software on your VAIO computer, you may be required to restart the computer.

1. Save your data and close all running software applications.
2. Click  (Start),  (arrow) next to the Shut down button, and Restart.  
Your VAIO computer will restart.

---

### Related Topic

[Turning on Your VAIO Computer](#)[Shutting Down Your VAIO Computer](#)

---



[▶ Troubleshooting](#)

## How to Use

---

[Parts Description](#)

---

[Setup](#)

---

[Network / Internet](#)

---

[Connections](#)

---

[Settings](#)

---

[View](#)

---

[Playback](#)

---

[Backup / Recovery](#)

---

[Security](#)

---

[Other Operations](#)

---

[Notifications](#)

---

[MONITOR Function](#)

---

## Selecting a Power Plan

Power management helps you set up power plans to suit your requirements for power consumption.

1. Click  (Start), Control Panel, Hardware and Sound, and Power Options.
  2. Select your desired power plan.
  3. If you want to change the power plan settings, click Change plan settings on the right of your desired power plan in the Power Options window.  
By clicking Change advanced power settings, you can change the advanced settings.  
Refer to Windows Help and Support for more information on the power plan settings.
-

[▶ Troubleshooting](#)**How to Use**[Parts Description](#)[Setup](#)[Network / Internet](#)[Connections](#)[Settings](#)[View](#)[Playback](#)[Backup / Recovery](#)[Security](#)[Other Operations](#)[Notifications](#)[MONITOR Function](#)

## Using Sleep Mode

In Sleep mode, all unnecessary devices of your VAIO computer are turned off, though some devices stay on to retain the computer's state including data you are working on. Sleep mode is useful when you take a short rest, for example.

With the default Sleep mode settings, Rapid Wake is enabled and the computer's state is saved to the built-in storage device.

### To activate Sleep mode

1. Click (Start), (arrow) next to the Shut down button, and Sleep.  
The power indicator light turns off when your VAIO computer enters Sleep mode.

#### Hint

- By default, your VAIO computer enters Sleep mode automatically after about 30 minutes of inactivity while running on AC power.
- The operations below also place your VAIO computer into Sleep mode.
  - Press the (Power) button (with the default setting).  
Note that if you press and hold down the (Power) button for more than four seconds, your VAIO computer will turn off automatically. Doing this will erase all unsaved data.
  - Press the Sleep button on the keyboard.

### To return to Normal mode

1. Press the (Power) button.

#### Note

- Before moving your VAIO computer, make sure that the power indicator light is off to avoid impact or vibration to the running hard disk drive.

#### Hint

- If you press and hold down the (Power) button for more than four seconds, your VAIO computer will turn off automatically. Doing this will erase all unsaved data.
- The operations below also restore your VAIO computer from Sleep mode to Normal mode.
  - Click the mouse button. (Mouse supplied models)
  - Move the mouse. (Wireless mouse supplied models)  
We recommend that you turn off the power switch of the wireless mouse before placing your VAIO computer into Sleep mode. This will prevent the computer from returning to Normal mode when the mouse is unintentionally moved during Sleep mode.

#### Related Topic

[Notes on Using the Power Source](#)[Notes on Sleep Mode](#)



[▶ Troubleshooting](#)

## How to Use

---

[Parts Description](#)

---

---

[Setup](#)

---

---

[Network / Internet](#)

---

---

[Connections](#)

---

---

[Settings](#)

---

---

[View](#)

---

---

[Playback](#)

---

---

[Backup / Recovery](#)

---

---

[Security](#)

---

---

[Other Operations](#)

---

---

[Notifications](#)

---

---

[MONITOR Function](#)

---

## About Home Network Setup (MONITOR Function)

This topic explains the home network setting.

This setting allows you to use the following functions/features.

- Displays the connected server list for selection.
- Diagnoses whether your VAIO computer can connect to each server on the home network.
- Enables a mobile device (e.g. smartphone) to work as the computer's remote control via the network, or the computer to play photo/music/video files on a device (e.g. digital still camera) by operating the device via the network.

---

### Related Topic

[Displaying the Menu Screen \(MONITOR Function\)](#)

---

[▶ Troubleshooting](#)

## How to Use

---

[Parts Description](#)

---

---

[Setup](#)

---

---

[Network / Internet](#)

---

---

[Connections](#)

---

---

[Settings](#)

---

---

[View](#)

---

---

[Playback](#)

---

---

[Backup / Recovery](#)

---

---

[Security](#)

---

---

[Other Operations](#)

---

---

[Notifications](#)

---

---

[MONITOR Function](#)

---

## About Media Remote

Media Remote allows another device (for example, smartphone, PC) to control an input state other than PC such as HDMI input function via the network.

In addition to the basic remote control functionality, you can enter text using the other device when the computer's software keyboard is displayed.

The following is required to use this feature.

- In the case of a smartphone: An Android OS-equipped phone or iPhone to which the Media Remote application is downloaded and installed.

### Hint

- The information about Media Remote is as of March 2012. The name and available functions of this application are subject to change.

---

### Related Topic

[Connecting to a Home Network](#)

---



[▶ Troubleshooting](#)**How to Use**[Parts Description](#)[Setup](#)[Network / Internet](#)[Connections](#)[Settings](#)[View](#)[Playback](#)[Backup / Recovery](#)[Security](#)[Other Operations](#)[Notifications](#)[MONITOR Function](#)

## Connecting to a Home Network

You can enjoy various content (for example, photo/music/video files) stored on DLNA-certified media servers. The home network feature allows you to enjoy network content in other rooms.

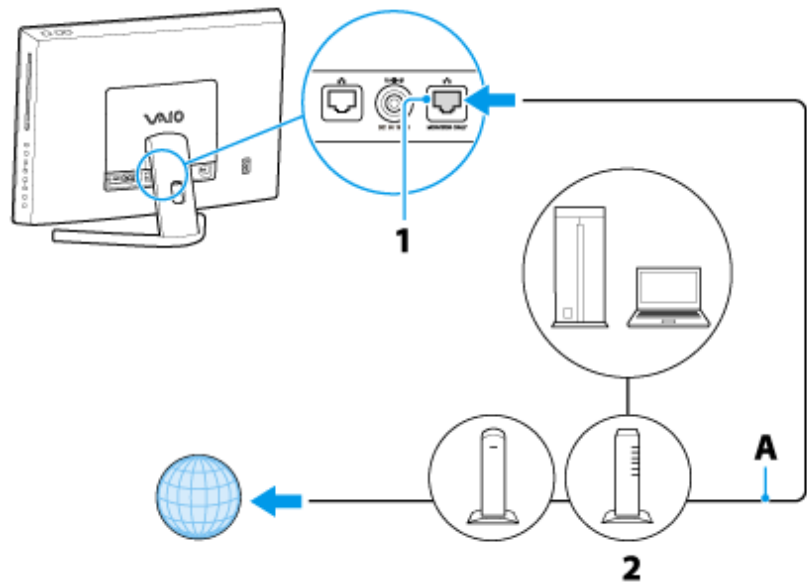
1. Connect the  MONITOR ONLY LAN port (1) of your VAIO computer and LAN port of modem/router (connected to the network device) (2) with a LAN cable (A) (not supplied).

**Hint**

- For connecting to a home network, you can use the  LAN port of the computer [\[Details\]](#) instead of the  MONITOR ONLY LAN port.

[▶ Troubleshooting](#)

## How to Use

---

[Parts Description](#)

---

[Setup](#)

---

[Network / Internet](#)

---

[Connections](#)

---

[Settings](#)

---

[View](#)

---

[Playback](#)

---

[Backup / Recovery](#)

---

[Security](#)

---

[Other Operations](#)

---

[Notifications](#)

---

[MONITOR Function](#)

---

## About the Internet Connection Services

The following types of Internet connection services are available. You can select from among the services according to your preference, for example, communication speed or a usage fee. For detailed information on a variety of connection services, contact Internet Service Providers (ISPs).

- Fiber to the Home (FTTH)
- Cable modem
- Digital Subscriber Line (DSL)
- Satellite
- Dial-up

---

### Related Topic

[Connecting to the Internet with a Wired Connection](#)  
[Starting Wireless LAN Communications](#)

---

[▶ Troubleshooting](#)

## How to Use

---

[Parts Description](#)

---

---

[Setup](#)

---

---

[Network / Internet](#)

---

---

[Connections](#)

---

---

[Settings](#)

---

---

[View](#)

---

---

[Playback](#)

---

---

[Backup / Recovery](#)

---

---

[Security](#)

---

---

[Other Operations](#)

---

---

[Notifications](#)

---

---

[MONITOR Function](#)

---

## About the Network (LAN)

The network (LAN) enables you to connect your VAIO computer to the Internet and transfer data between the computer and other devices.

You can connect your VAIO computer to 1000BASE-T/100BASE-TX/10BASE-T type networks with a LAN cable (not supplied). Connect one end of a LAN cable to the LAN port on the computer and the other end to your network.

For information on peripheral devices required for LAN access, ask your Internet Service Provider (ISP) or refer to the manual that came with your modem.

For information on how to connect your VAIO computer to the network, refer to your ISP's instructions or the manual that came with the modem and other peripheral devices. If you require information on the network settings at your workplace, ask the network administrator.

### Note

- The MONITOR ONLY LAN port does not support the 1000BASE-T type network connection.

---

### Related Topic

[About the Internet Connection Services](#)  
[Starting Wireless LAN Communications](#)

---



[▶ Troubleshooting](#)**How to Use**

---

[Parts Description](#)

---

---

[Setup](#)

---

---

[Network / Internet](#)

---

---

[Connections](#)

---

---

[Settings](#)

---

---

[View](#)

---

---

[Playback](#)

---

---

[Backup / Recovery](#)

---

---

[Security](#)

---

---

[Other Operations](#)

---

---

[Notifications](#)

---

---

[MONITOR Function](#)

---

## About the Wireless LAN Standards

The Wireless Local Area Network (WLAN) allows your VAIO computer to connect to a network through a wireless connection.

The WLAN uses the following IEEE 802.11a/b/g/n standard, which specifies the type of technology used.

Refer to the specifications to find out about the configuration of the computer.

IEEE 802.11a (Frequency band:5 GHz)

Exclusive to models compliant with the IEEE 802.11a/b/g/n standard.

IEEE 802.11b/g (Frequency band:2.4 GHz)

The IEEE 802.11g standard provides higher-speed communications than the IEEE 802.11b.

IEEE 802.11n (Frequency band:2.4 GHz/5 GHz)

For models compliant with the IEEE 802.11b/g/n standard, only 2.4 GHz band can be used.

---

### Related Topic

[Before Using the Wireless LAN](#)

[Starting Wireless LAN Communications](#)

[Stopping Wireless LAN Communications](#)

[Notes on Using the Wireless LAN Function](#)

---

[▶ Troubleshooting](#)**How to Use**[Parts Description](#)[Setup](#)[Network / Internet](#)[Connections](#)[Settings](#)[View](#)[Playback](#)[Backup / Recovery](#)[Security](#)[Other Operations](#)[Notifications](#)[MONITOR Function](#)

## Connecting to the Internet with a Wired Connection

Before using the Internet, you need to sign up with an Internet Service Provider (ISP) and set up devices required for connecting your VAIO computer to the Internet. Connect one end of a LAN cable (not supplied) to the LAN port on your VAIO computer and the other end to your network.

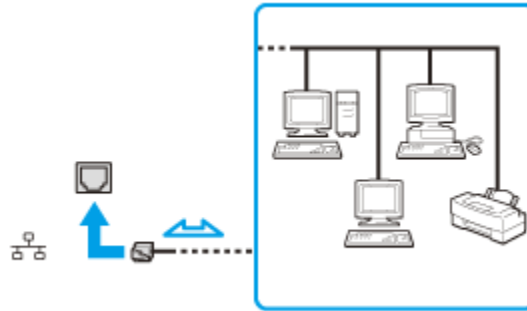
**Note**

- For detailed information on devices required for Internet access and how to connect your VAIO computer to the Internet, ask your ISP.
- To connect your VAIO computer to the Internet while Windows is running, connect a LAN cable to the LAN port for the PC. You cannot use the Internet with the MONITOR ONLY LAN port while Windows is running.
- When connecting your VAIO computer to the Internet, be sure to use a cable with network or Ethernet printed on it.
- Do not plug a telephone cable into the LAN port on your VAIO computer. If the computer is connected to the one of the networks or the LAN port is connected to the telephone lines mentioned below, high electric current to the port may cause damage, overheating, or fire.
  - Any network, except 1000BASE-T/100BASE-TX/10BASE-T type networks
  - Public telephone subscriber line
  - Private branch exchange (PBX)
  - Home (intercom speakerphone) or business-use telephone lines (multi-line business telephone)

**Hint**

- To connect your VAIO computer to the Internet using the wireless LAN function, you need to set up the wireless LAN network. [\[Details\]](#)

**Related Topic**[About the Internet Connection Services](#)[About the Network \(LAN\)](#)[Starting Wireless LAN Communications](#)



[▶ Troubleshooting](#)

## How to Use

---

[Parts Description](#)

---

---

[Setup](#)

---

---

[Network / Internet](#)

---

---

[Connections](#)

---

---

[Settings](#)

---

---

[View](#)

---

---

[Playback](#)

---

---

[Backup / Recovery](#)

---

---

[Security](#)

---

---

[Other Operations](#)

---

---

[Notifications](#)

---

---

[MONITOR Function](#)

---

## About a Security Key for a Wireless LAN

A security key is a security protocol for a wireless LAN that encrypts data transmitted on the wireless LAN. It is also referred to as an encryption key or a WEP (Wired Equivalent Privacy) key.

The security key allows wireless devices that have the same key, such as a wireless LAN access point and a computer, to communicate with each other on the wireless LAN.

The security key is assigned to each access point by default. (Make sure the default security key has been changed to protect data from unauthorized use.) If you cannot find the default security key, refer to the manual that came with your access point.

If you enter a wrong security key, follow these steps to re-enter the security key.

1. Click  (Start) and Control Panel.
2. Click Network and Internet and Network and Sharing Center.
3. Click Manage wireless networks in the left pane.
4. Right-click the desired network in the Networks you can view and modify list, and then click Properties.
5. Click the Security tab.
6. Enter a security key in the Network security key field and click OK.

---

### Related Topic

[About the Wireless LAN Standards](#)

[Before Using the Wireless LAN](#)

[Starting Wireless LAN Communications](#)

[Notes on Using the Wireless LAN Function](#)

---

[▶ Troubleshooting](#)

## How to Use

---

[Parts Description](#)

---

---

[Setup](#)

---

---

[Network / Internet](#)

---

---

[Connections](#)

---

---

[Settings](#)

---

---

[View](#)

---

---

[Playback](#)

---

---

[Backup / Recovery](#)

---

---

[Security](#)

---

---

[Other Operations](#)

---

---

[Notifications](#)

---

---

[MONITOR Function](#)

---

## Before Using the Wireless LAN

You first need to establish wireless LAN communications between your VAIO computer and an access point (not supplied) before connecting the computer to the Internet using the wireless LAN. Refer to Windows Help and Support and the manual that came with your access point for more information.

For a quick and easy connection to the wireless LAN

When the first time you connect your VAIO computer to the Internet using the wireless LAN at home or connect the computer to a public wireless network (hotspot), use VAIO Easy Connect that helps you establish a connection to the wireless LAN quickly and easily.

1. Click  (Start), All Programs, VAIO Easy Connect, and follow the on-screen instructions in the Easy Internet Connection Setup window.

---

### Related Topic

[About the Wireless LAN Standards](#)

[Starting Wireless LAN Communications](#)

[Stopping Wireless LAN Communications](#)

[Notes on Using the Wireless LAN Function](#)

[About a Security Key for a Wireless LAN](#)

---

[▶ Troubleshooting](#)**How to Use**[Parts Description](#)[Setup](#)[Network / Internet](#)[Connections](#)[Settings](#)[View](#)[Playback](#)[Backup / Recovery](#)[Security](#)[Other Operations](#)[Notifications](#)[MONITOR Function](#)

## Notes on Using the Wireless LAN Function

Before using the wireless LAN function, read the following precautions for correct use.

- In some countries or regions, using the wireless LAN products may be restricted by the local regulations.
- Wireless LAN devices work on the 2.4 GHz band, which is used by a variety of devices. Wireless LAN devices use the technology to minimize radio interference from other devices that use the same band; however, radio interference may still slow communication speeds, reduce communication range, or cause communication failure.
- If both the BLUETOOTH function and the 2.4 GHz wireless LAN function of your VAIO computer are enabled, interference may occur and cause slower communication speeds or other problems.
- The communication speed and range may vary depending on the following conditions:
  - Distance between devices
  - Existence of obstacles between devices
  - Device configuration
  - Radio conditions
  - Ambient environment (including wall material, etc.)
  - Software in use
 Communications may be cut off depending on radio conditions.
- The data transfer rate specified in the specification is the theoretical maximum, and may not reflect actual data transfer rate.
- Actual communication speed may not be as fast as the one displayed on your VAIO computer.
- The 2.4 GHz wireless LAN and 5 GHz wireless LAN frequency bands are not communicable with one another.
- The data transfer rate of IEEE 802.11g and IEEE 802.11n (2.4 GHz) may be affected by interference when used with an IEEE 802.11b product. Also, IEEE 802.11g and IEEE 802.11n automatically lower the transfer rate to maintain compatibility with an IEEE 802.11b product. The transfer rate may be regained by changing the channel settings of your access point.
- The IEEE 802.11a standard and the IEEE 802.11n standard are not available on ad-hoc networks.
- To stop the wireless LAN function abruptly, turn off your VAIO computer.
- The WLAN standard includes the encryption methods: Wired Equivalent Privacy (WEP), which is a security protocol, Wi-Fi Protected Access 2 (WPA2), and Wi-Fi Protected Access (WPA). Proposed jointly by the IEEE and Wi-Fi Alliance, both WPA2 and WPA are specifications of standards based on interoperable security enhancements that increase the level of data protection and access control for existing Wi-Fi networks. WPA is designed to be forward compatible with the IEEE 802.11i specification. It utilizes the enhanced data encryption Temporal Key Integrity Protocol (TKIP) in addition to user authentication using 802.1X and Extensible Authentication Protocol (EAP). Data encryption protects the vulnerable wireless link between clients and access points. Besides that, there are other typical LAN security mechanisms to ensure privacy, such as: password protection, end-to-end encryption, virtual private networks, and authentication. WPA2, the second generation of WPA, provides stronger data protection and network access control and is also designed to secure all versions of 802.11 devices, including 802.11b, 802.11a, 802.11g, and 802.11n standards, multi-band and

multi-mode. In addition, based on the ratified IEEE 802.11i standard, WPA2 provides government grade security by implementing the National Institute of Standards and Technology (NIST) FIPS 140-2 compliant AES encryption algorithm and 802.1X-based authentication. WPA2 is backward compatible with WPA.

---

Related Topic

[About the Wireless LAN Standards](#)

[Before Using the Wireless LAN](#)

[Starting Wireless LAN Communications](#)

[Stopping Wireless LAN Communications](#)

[Notes on Using the BLUETOOTH\(R\) Function<BLUETOOTH equipped models>](#)

---

[▶ Troubleshooting](#)**How to Use**[Parts Description](#)[Setup](#)[Network / Internet](#)[Connections](#)[Settings](#)[View](#)[Playback](#)[Backup / Recovery](#)[Security](#)[Other Operations](#)[Notifications](#)[MONITOR Function](#)

## Starting Wireless LAN Communications

You can establish wireless LAN communications between your VAIO computer and an access point (not supplied) using VAIO Smart Network. Before using the wireless LAN, make sure your access point is on and operating.

Read the instructions in [Before Using the Wireless LAN](#) for correct use. [\[Details\]](#)

1. Click (Start), All Programs, and VAIO Smart Network or click (the VAIO Smart Network icon) in the desktop notification area.

2. Make sure that the switch next to Wireless LAN or Wi-Fi is toggled to On. If it is set to Off, click it to toggle to On.

Hint

- Make sure the WIRELESS indicator light [\[Details\]](#) is on.
- You can use the Wi-Fi Direct function if Wi-Fi Direct is displayed in the VAIO Smart Network window. Refer to the help file included with VAIO Smart Network for more information.

3. In the VAIO Smart Network window, select a mode that suits your wireless LAN. Refer to the help file included with VAIO Smart Network for more information about operations.

4. Click or (the Network icon) in the desktop notification area.

5. Select the desired access point and click Connect.

After the connection is established, Connected appears in the selected wireless access point field.

If you cannot find the desired access point, click (Refresh).

If a security key [\[Details\]](#) entry window appears, enter the security key as required and click OK. Note that security keys are case-sensitive.

**Note**

- It may take some time to find and connect to a wireless LAN access point before starting communications via the wireless LAN.

Hint

- Once you connect your VAIO computer to the access point by entering the security key, the access point will be registered in the computer. You do not have to enter the security key for subsequent connections.

### To check wireless LAN connection status

You can move the mouse pointer over or (the Network icon) in the desktop notification area to check the wireless LAN connection status, such as the access point currently connected to your VAIO computer.

**Related Topic**

[About the Wireless LAN Standards](#)

[Before Using the Wireless LAN](#)

[Stopping Wireless LAN Communications](#)

[Notes on Using the Wireless LAN Function](#)





[▶ Troubleshooting](#)

## How to Use

---

[Parts Description](#)

---

[Setup](#)

---

[Network / Internet](#)

---

[Connections](#)

---

[Settings](#)

---

[View](#)

---

[Playback](#)

---

[Backup / Recovery](#)

---

[Security](#)

---

[Other Operations](#)

---

[Notifications](#)

---

[MONITOR Function](#)

---

## Stopping Wireless LAN Communications

Stop wireless LAN communications using VAIO Smart Network.

1. Click the switch next to Wireless LAN or Wi-Fi to toggle it to Off in the VAIO Smart Network window.

The wireless LAN function is disabled and the WIRELESS indicator light turns off.

### Note

- Do not disable the wireless LAN function while accessing remote documents, files, or resources, as it may result in data loss.

### Hint

- When another wireless communication function is enabled in the VAIO Smart Network window, the WIRELESS indicator light on your VAIO computer stays on.

---

### Related Topic

[About the Wireless LAN Standards](#)[Starting Wireless LAN Communications](#)[Notes on Using the Wireless LAN Function](#)

---

[▶ Troubleshooting](#)

## How to Use

---

[Parts Description](#)

---

[Setup](#)

---

[Network / Internet](#)

---

[Connections](#)

---

[Settings](#)

---

[View](#)

---

[Playback](#)

---

[Backup / Recovery](#)

---

[Security](#)

---

[Other Operations](#)

---

[Notifications](#)

---

[MONITOR Function](#)

---

## About Network Setup (MONITOR Function)

This topic explains the network setting of the  MONITOR ONLY LAN port. This setting allows you to use the following functions/features.

- Displays the network status and settings.
- Allows configuration of your wired network.
- Sets the IP address and the proxy server.

---

### Related Topic

[Displaying the Menu Screen \(MONITOR Function\)](#)

---

[▶ Troubleshooting](#)

## How to Use

---

[Parts Description](#)

---

[Setup](#)

---

[Network / Internet](#)

---

[Connections](#)

---

[Settings](#)

---

[View](#)

---

[Playback](#)

---

[Backup / Recovery](#)

---

[Security](#)

---

[Other Operations](#)

---

[Notifications](#)

---

[MONITOR Function](#)

---

## Launching the Web Browser (WEB Button)

By pressing the WEB button, you can launch the default web browser.

Even when your VAIO computer is off, pressing the WEB button starts Windows, and launches the web browser.

---

[▶ Troubleshooting](#)

## How to Use

[Parts Description](#)[Setup](#)[Network / Internet](#)[Connections](#)[Settings](#)[View](#)[Playback](#)[Backup / Recovery](#)[Security](#)[Other Operations](#)[Notifications](#)[MONITOR Function](#)

## Using the Antivirus Software for Your VAIO Computer

Protect your VAIO computer against computer viruses by using the antivirus software. You can keep the antivirus software current with the latest updates by downloading and installing the updates from the website of the software publisher. To update the antivirus software, find the antivirus software installed on your VAIO computer from the following and follow these steps.

Trend Micro:

1. Make sure your VAIO computer is connected to the Internet, click  (Start), All Programs, Trend Micro Titanium Maximum Security 2012, and Trend Micro Titanium Maximum Security 2012.
2. Follow the on-screen instructions.

McAfee:

1. Make sure your VAIO computer is connected to the Internet, click  (Start), All Programs, McAfee, and McAfee Internet Security or McAfee Total Protection.
2. Follow the on-screen instructions.

Kaspersky Internet Security:

1. Make sure your VAIO computer is connected to the Internet, click  (Start), All Programs, Kaspersky Internet Security, and Kaspersky Internet Security.
2. Follow the on-screen instructions.

### Note

- The actual procedure may be different from the above depending on the version of the software installed on your VAIO computer. In such a case, follow the on-screen instructions.

Hint

- Refer to the help file included with your software for more information.

[▶ Troubleshooting](#)

## How to Use

---

[Parts Description](#)

---

[Setup](#)

---

[Network / Internet](#)

---

[Connections](#)

---

[Settings](#)

---

[View](#)

---

[Playback](#)

---

[Backup / Recovery](#)

---

[Security](#)

---

[Other Operations](#)

---

[Notifications](#)

---

[MONITOR Function](#)

---

## About HDMI Settings / HDMI Setup (MONITOR Function)

This topic explains the settings for the “Control for HDMI” function.

This setting allows you to use the following functions/features.

- Links operations of your VAIO computer and connected equipment.
- Turns on the computer when you turn on or perform playback, etc., on connected equipment.
- Turns off the connected equipment when you turn off the computer.
- Displays a list of connected equipment compatible with “Control for HDMI.”
- Operates connected equipment by the computer’s remote control.

---

### Related Topic

[Displaying the Menu Screen \(MONITOR Function\)](#)

---

[▶ Troubleshooting](#)

## How to Use

---

[Parts Description](#)

---

[Setup](#)

---

[Network / Internet](#)

---

[Connections](#)

---

[Settings](#)

---

[View](#)

---

[Playback](#)

---

[Backup / Recovery](#)

---

[Security](#)

---

[Other Operations](#)

---

[Notifications](#)

---

[MONITOR Function](#)

---

## About the USB Auto Start Settings (MONITOR Function)

Starts a slideshow automatically using photos stored in a connected USB device, such as a digital camera.

---

### Related Topic

[Displaying the Menu Screen \(MONITOR Function\)](#)

---

[▶ Troubleshooting](#)

## How to Use

---

[Parts Description](#)

---

[Setup](#)

---

[Network / Internet](#)

---

[Connections](#)

---

[Settings](#)

---

[View](#)

---

[Playback](#)

---

[Backup / Recovery](#)

---

[Security](#)

---

[Other Operations](#)

---

[Notifications](#)

---

[MONITOR Function](#)

---

## About "BRAVIA" Sync

With the "BRAVIA" Sync function, you can use the computer's remote to operate "Control for HDMI"-compatible equipment that is connected to your VAIO computer with an HDMI cable.

---

### Related Topic

[Operating "Control for HDMI"-Compatible Equipment](#)

---



[▶ Troubleshooting](#)

## How to Use

---

[Parts Description](#)

---

[Setup](#)

---

[Network / Internet](#)

---

[Connections](#)

---

[Settings](#)

---

[View](#)

---

[Playback](#)

---

[Backup / Recovery](#)

---

[Security](#)

---

[Other Operations](#)

---

[Notifications](#)

---

[MONITOR Function](#)

---

## Changing the Sound Output Device

If there is no sound from the device connected to your VAIO computer, you need to change the device for sound output.

### Hint

- Follow these steps to change only the sound output device for the PC.  
To simultaneously change all sound output devices including those used for the HDMI/VIDEO input function, see [About the Speakers Settings](#). [\[Details\]](#)
1. Click (Start) and Control Panel.
  2. Click Hardware and Sound.
  3. Click Sound.
  4. Click the Playback tab.
  5. Ensure there is a check mark next to the icon of the device you intend to output computer sound from.  
If there is no check mark next to the icon, select it and click Set Default.
  6. Click OK.

### To change the sound rate and bit depth

The sound rate and bit depth of the digital audio output signal should be set according to your digital audio device. Follow these steps.

1. Click (Start) and Control Panel.
2. Click Hardware and Sound.
3. Click Sound.
4. Click the Playback tab.
5. Select the icon of your HDMI device or OPTICAL OUT (optical digital audio output) and click Properties.
6. Click the Advanced tab.
7. Select the sample rate and bit depth (for example, 16 bit, 48000 Hz (DVD quality)) which the device supports.
8. Click OK.

---

### Related Topic

[Connecting External Speakers or Headphones](#)[Connecting a High-Quality Digital Sound Output Device between Your VAIO Computer and a TV](#)

[▶ Troubleshooting](#)

## How to Use

---

[Parts Description](#)

---

[Setup](#)

---

[Network / Internet](#)

---

[Connections](#)

---

[Settings](#)

---

[View](#)

---

[Playback](#)

---

[Backup / Recovery](#)

---

[Security](#)

---

[Other Operations](#)

---

[Notifications](#)

---

[MONITOR Function](#)

---

## Connecting a High-Quality Digital Sound Output Device between Your VAIO Computer and a TV

You can connect a high-quality home theater receiver or other surround sound decoder devices between your VAIO computer and a TV using an HDMI connection.

1. Make sure the HDMI connection has been set up between the TV and the home theater receiver or surround sound decoder device.
2. Change the device for sound output to the HDMI output. [\[Details\]](#)
3. Turn on the TV and set its input to the HDMI input.
4. Turn on the home theater receiver or surround sound decoder device and set its input to the HDMI input.
5. Plug one end of an HDMI cable to the HDMI input port on the home theater receiver or surround sound decoder device and the other end to the HDMI output port on your VAIO computer.

### Hint

- You can adjust the screen resolution of the connected TV with your VAIO computer. [\[Details\]](#)
- With the HDMI connection, the volume can be adjusted by the connected audio device only. Your VAIO computer has no control over the output volume of any connected devices.

---

### Related Topic

[Changing the Sound Output Device](#)[Changing the Resolution \(Size\) of the Screen Image](#)[Connecting a TV with an HDMI Input Port](#)

---

▶ Troubleshooting

How to Use

Parts Description

Setup

Network / Internet

Connections

Settings

View

Playback

Backup / Recovery

Security

Other Operations

Notifications

MONITOR Function

## Connecting a VCR or DVD Player

By connecting a VCR or DVD player to your VAIO computer, you can enjoy pictures on the computer screen.

### HDMI Cable Connection

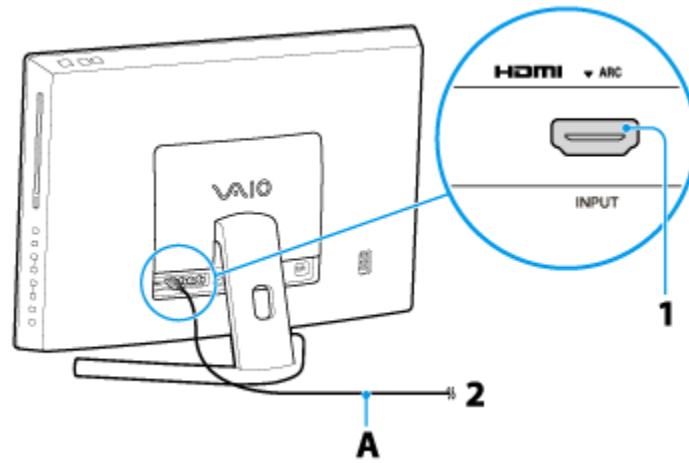

1. Connect an HDMI cable (A) (not supplied) to the HDMI INPUT port (1) of your VAIO computer.
2. Connect the other end of the HDMI cable (A) (not supplied) to the HDMI output port (2) of the VCR or DVD player.

### Analog AV Cable Connection

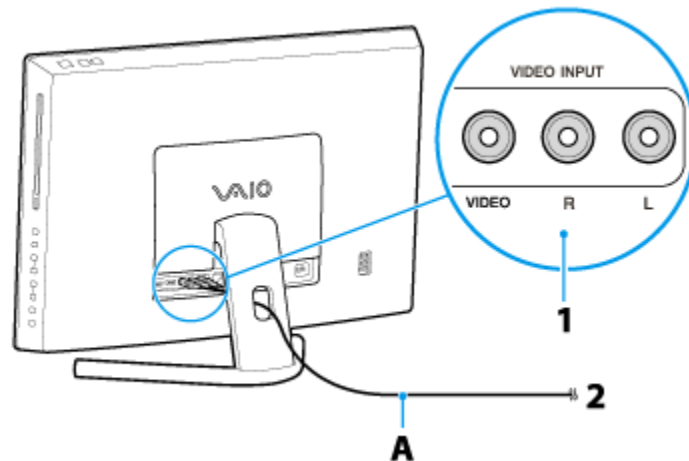

1. Connect an analog AV cable (A) (not supplied) to the VIDEO INPUT jacks (1) of your VAIO computer.
2. Connect the other end of the analog AV cable (A) (not supplied) to the audio/video output jacks (2) of the VCR or DVD player.

---

Related Topic

[Viewing Pictures from Connected Equipment](#)

---

▶ Troubleshooting

How to Use

---

Parts Description

---

Setup

---

Network / Internet

---

Connections

---

Settings

---

View

---

Playback

---

Backup / Recovery

---

Security

---

Other Operations

---

Notifications

---

MONITOR Function

---

## Connecting an Audio System

Connect an audio system such as an AV amplifier or a home theater system to your VAIO computer.

### HDMI Cable Connection

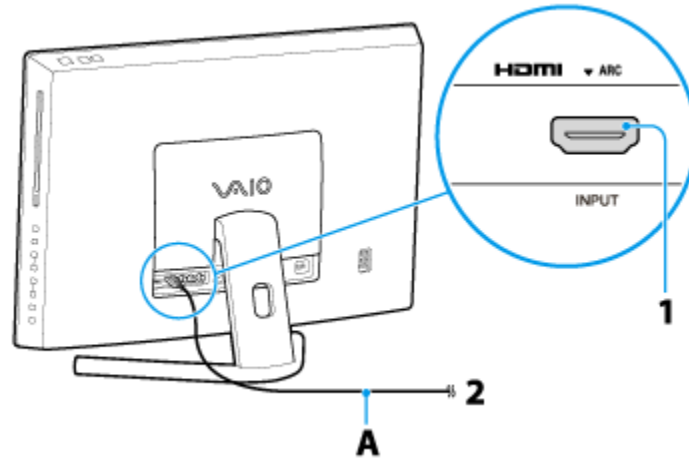

1. Connect an HDMI cable (A) (not supplied) to the HDMI INPUT port (1) of your VAIO computer.
2. Connect the other end of the HDMI cable (A) (not supplied) to the HDMI output port (2) of an audio system.

Hint

- When connecting an audio system that is compatible with “Control for HDMI” and Audio Return Channel (ARC) technology, connect to the HDMI INPUT port of the computer with an HDMI cable.

### Audio Cable Connection

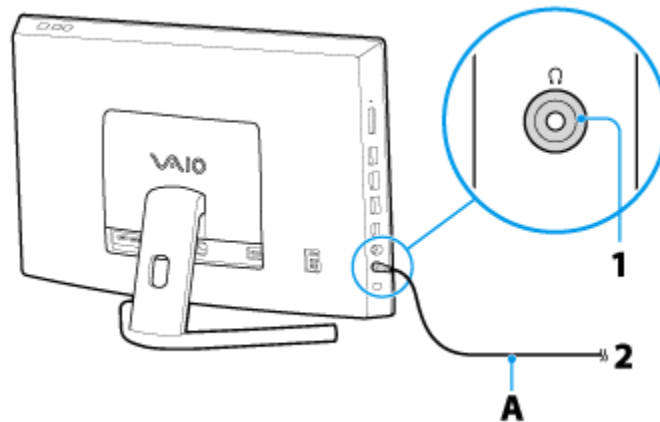

1. Connect an audio cable (A) (not supplied) to the (headphones) port (1) of your VAIO

computer.

2. Connect the other end of the audio cable (A) (not supplied) to the audio output port (2) of an audio system.

---

Related Topic

[Enjoying Sounds from Connected Audio System](#)

---

[▶ Troubleshooting](#)**How to Use**[Parts Description](#)[Setup](#)[Network / Internet](#)[Connections](#)[Settings](#)[View](#)[Playback](#)[Backup / Recovery](#)[Security](#)[Other Operations](#)[Notifications](#)[MONITOR Function](#)

## Connecting an External Microphone

You can connect an external microphone to your VAIO computer and enjoy voice chat, etc.

1. Plug the microphone cable into the microphone jack [\[Details\]](#).

**Note**

- If you connect or disconnect the microphone to/from your VAIO computer while running voice recording software, voice recording may fail or the software may exit. Connect the microphone and select it as the sound recording device for Windows before starting the software.

**Hint**

- Use a plug-in-power microphone.
- Refer to the manual that came with your microphone.
- If microphone feedback occurs, move the microphone away from your speakers.

**Related Topic**[Adjusting the Microphone Volume](#)[Connecting External Speakers or Headphones](#)

▶ [Troubleshooting](#)

**How to Use**

Parts Description

Setup

Network / Internet

Connections

Settings

View

Playback

Backup / Recovery

Security

Other Operations

Notifications

MONITOR Function

## Enjoying Sounds from Connected Audio System

Change the sound setting on your VAIO computer to output an audio signal to a connected audio system.

1. Turn on the connected equipment.
2. Press the HOME button on the remote, or the HOME button on the right side of your VAIO computer.

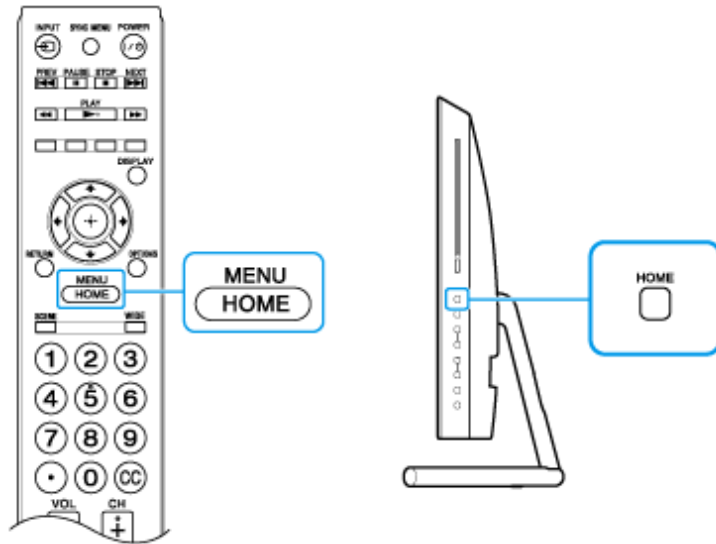

3. Select (Settings), Sound, Speakers, and Audio System.

Related Topic

[Connecting an Audio System](#)



## ▶ Troubleshooting

### How to Use

Parts Description

Setup

Network / Internet

Connections

Settings

View

Playback

Backup / Recovery

Security

Other Operations

Notifications

MONITOR Function

## Operating "Control for HDMI"-Compatible Equipment

With the "Control for HDMI" function, you can operate "Control for HDMI"-compatible equipment that is connected to your VAIO computer.

The "Control for HDMI" function helps communication between "Control for HDMI"-compatible equipment using HDMI CEC (Consumer Electronics Control).

To activate "Control for HDMI"

1. Connect the HDMI INPUT port [\[Details\]](#) of your VAIO computer and HDMI port of HDMI equipment with an HDMI cable (not supplied).
2. Turn on the connected equipment.
3. Press the HOME button on the remote, or the HOME button on the right side of the computer.

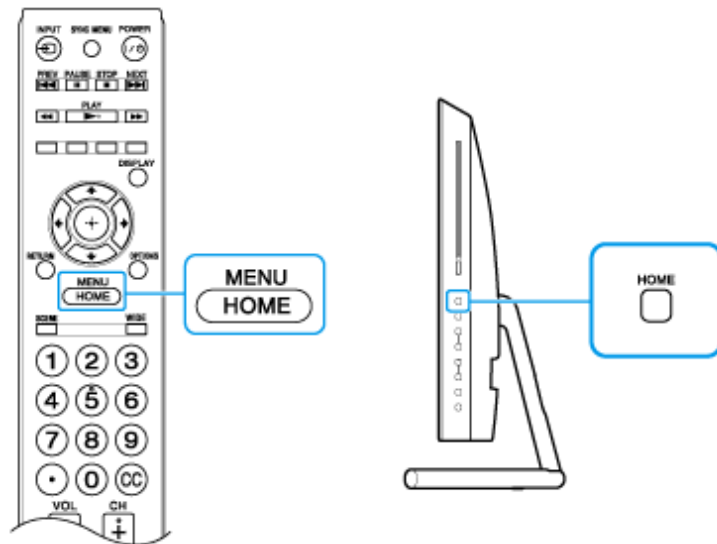

4. Select (Settings), Channels & Inputs, HDMI Settings, Control for HDMI, and On.

Hint

- By using the "BRAVIA" Sync Menu, you can turn on the connected HDMI equipment via the HDMI connection. To use the "BRAVIA" Sync Menu, press the SYNC MENU button on the remote commander.

To confirm activation of "Control for HDMI"

1. Press the HOME button on the remote or on the right side of the computer.
2. Select (Settings), Channels & Inputs, HDMI Settings, and Device List. When the connected equipment name is displayed on the Device List, then "Control for HDMI" has been activated. However if the name is not displayed, refer to the manual that came with the connected equipment and retry the settings.

### Note

- If you turn on connected “Control for HDMI”-compatible equipment while Windows is running, the display may automatically switch to the equipment’s display. To avoid this, turn on the “Control for HDMI”-compatible equipment before starting Windows, or deactivate the “Control for HDMI” function.

### Hint

- “Control for HDMI” is only available for connected Sony equipment that is compatible with “Control for HDMI.”
- When Sony equipment compatible with “Control for HDMI” is connected and powered on, and Control for HDMI is set to On, Control for HDMI of the equipment is automatically activated.

---

### Related Topic

[About “BRAVIA” Sync](#)

---

[▶ Troubleshooting](#)**How to Use**[Parts Description](#)[Setup](#)[Network / Internet](#)[Connections](#)[Settings](#)[View](#)[Playback](#)[Backup / Recovery](#)[Security](#)[Other Operations](#)[Notifications](#)[MONITOR Function](#)

## Viewing Pictures from Connected Equipment

Switch the input selector of your VAIO computer so that the signal from a connected VCR or DVD player appears on the computer screen.

1. Turn on the connected equipment.
2. Press the INPUT button on the remote, or the INPUT/OK button on the right side of your VAIO computer.

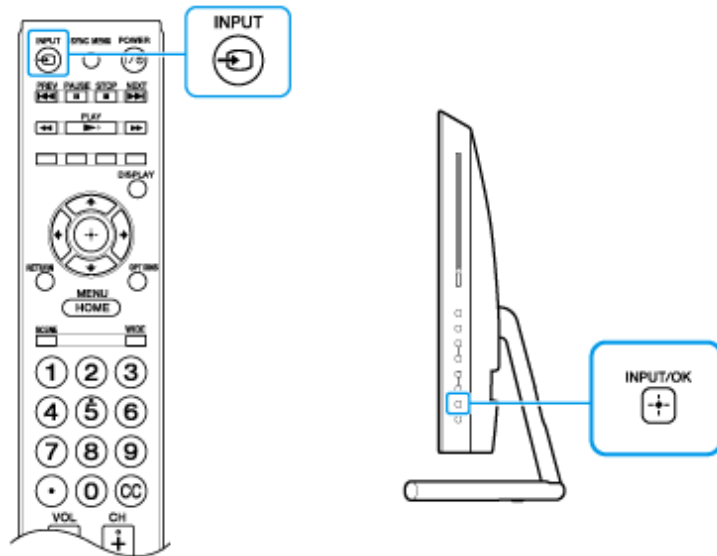

3. Select the input of the connected equipment.

**Hint**

- You can adjust the volume by pressing the VOL buttons on the remote, or the VOL buttons on the right side of your VAIO computer.

**Related Topic**

[Connecting a VCR or DVD Player](#)

[▶ Troubleshooting](#)

## How to Use

---

[Parts Description](#)

---

[Setup](#)

---

[Network / Internet](#)

---

[Connections](#)

---

[Settings](#)

---

[View](#)

---

[Playback](#)

---

[Backup / Recovery](#)

---

[Security](#)

---

[Other Operations](#)

---

[Notifications](#)

---

[MONITOR Function](#)

---

## About Antenna Connection <TV tuner board installed models>

To watch TV with your VAIO computer, you must first connect the necessary cables, such as for the antenna, etc.

Select one of the connection methods below, according to your connection environment.

- Connecting to Standard Cable Access (CATV) [\[Details\]](#)
- Connecting to a Standard Antenna [\[Details\]](#)
- Connecting to an Antenna (Air) for Digital Television System (ATSC Signal Standard) [\[Details\]](#)

### Note

- Some connection methods may not be applicable in some countries or regions.
- The state of receiving TV signals widely varies depending on services available in your country or region as well as connection types.
- No TV coaxial cables are supplied with your computer. Make sure that you have a sufficient number of TV coaxial cables ready beforehand.

» [Troubleshooting](#)

**How to Use**

Parts Description

Setup

Network / Internet

Connections

Settings

View

Playback

Backup / Recovery

Security

Other Operations

Notifications

MONITOR Function

**Connecting to Standard Cable Access (CATV)  
<TV tuner board installed models>**

You can connect your computer to an indoor/outdoor antenna system in CATV mode.

To connect in CATV mode (Option 1)

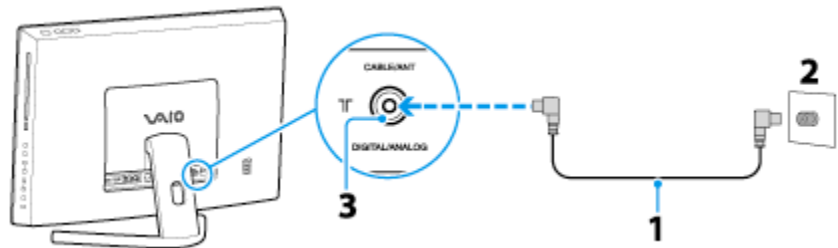

1. Connect one end of the TV coaxial cable (1) to your cable service access (wall outlet) (2).
2. Connect the other end to the **CABLE/ANT (DIGITAL/ANALOG)** port (3) on the computer.

To connect in CATV mode (Option 2)

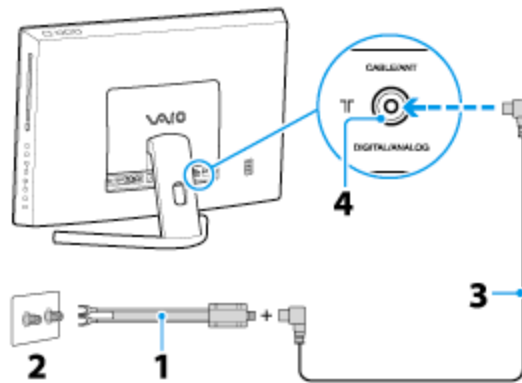

1. Connect the two metal hooks on a 75-ohm/300-ohm RCA transformer cable (1) to the screw-type grips at your cable service access (wall outlet) (2).
2. Connect one end of the TV coaxial cable (3) to the transformer end of the RCA transformer cable (1). Connect the other end to the **CABLE/ANT (DIGITAL/ANALOG)** port (4) on the computer.

Related Topic

[Connecting to a Standard Antenna<TV tuner board installed models>](#)

[Connecting to an Antenna \(Air\) for Digital Television System \(ATSC Signal Standard\)<TV tuner board installed models>](#)



» Troubleshooting

How to Use

Parts Description

Setup

Network / Internet

Connections

Settings

View

Playback

Backup / Recovery

Security

Other Operations

Notifications

MONITOR Function

## Connecting to a Standard Antenna <TV tuner board installed models>

Depending on the type of antenna system in your home, your connection may require a VHF/UHF RF combiner/transformer to connect the computer and the indoor/outdoor antenna system.

Hint

- If you are connecting to an indoor/outdoor antenna, you may need to reorient the antenna for best reception. Move the antenna cable away from other power sources or connectors to reduce signal interference.

To connect in land-based (terrestrial) broadcasting mode (Option 1)

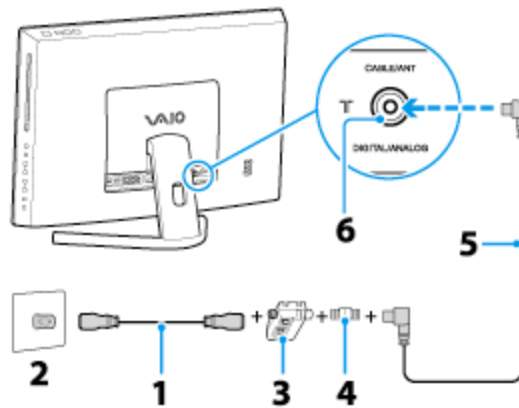

1. Connect one end of a TV coaxial cable (1) to your antenna outlet (2). Connect the other end to a VHF/UHF RF combiner/transformer (3).
2. Connect a coaxial cable feed connector (4) to the VHF/UHF RF combiner/transformer (3).
3. Connect one end of another TV coaxial cable (5) to the feed connector (4). Connect the other end to the **T** CABLE/ANT (DIGITAL/ANALOG) port (6) on the computer.

To connect in land-based (terrestrial) broadcasting mode (Option 2)

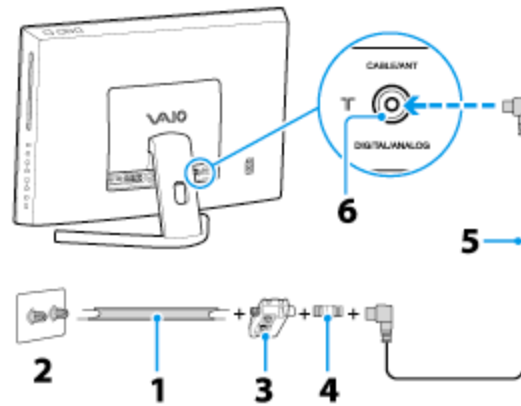

1. Connect one end of a 300-ohm twin lead cable (1) to the screw-type grips at your antenna outlet (2). Connect the other end to the grips on a VHF/UHF RF combiner/transformer (3).
2. Connect a coaxial cable feed connector (4) to the VHF/UHF RF combiner/transformer (3).
3. Connect one end of the TV coaxial cable (5) to the feed connector (4). Connect the other end to the **CABLE/ANT (DIGITAL/ANALOG)** port (6) on the computer.

---

#### Related Topic

[Connecting to Standard Cable Access \(CATV\)<TV tuner board installed models>](#)

[Connecting to an Antenna \(Air\) for Digital Television System \(ATSC Signal Standard\)<TV tuner board installed models>](#)

---



[▶ Troubleshooting](#)**How to Use**

---

[Parts Description](#)

---

[Setup](#)

---

[Network / Internet](#)

---

[Connections](#)

---

[Settings](#)

---

[View](#)

---

[Playback](#)

---

[Backup / Recovery](#)

---

[Security](#)

---

[Other Operations](#)

---

[Notifications](#)

---

[MONITOR Function](#)

---

## About the Cable/Antenna Settings (MONITOR Function) <TV tuner board installed models>

Sets the received signal to Cable or Antenna.

**Note**

- After changing this setting, it is recommended to run Auto Program.

---

**Related Topic**

[Displaying the Menu Screen \(MONITOR Function\)](#)

---

[▶ Troubleshooting](#)**How to Use**[Parts Description](#)[Setup](#)[Network / Internet](#)[Connections](#)[Settings](#)[View](#)[Playback](#)[Backup / Recovery](#)[Security](#)[Other Operations](#)[Notifications](#)[MONITOR Function](#)

## About BLUETOOTH(R) Security <BLUETOOTH equipped models>

The BLUETOOTH wireless technology has an authentication function, which allows you to control communication with other devices.

The authentication function helps you prevent unwanted anonymous BLUETOOTH devices from accessing your VAIO computer. The first time two BLUETOOTH devices communicate, a common passkey (a password required for authentication) should be identified to register both devices. Once a device is registered, there is no need to re-enter the passkey.

Your VAIO computer can prevent unauthorized BLUETOOTH devices from finding it and control which devices are allowed to connect with it.

For details, click  (Start) and Help and Support to open Windows Help and Support, and then enter "BLUETOOTH" in the search box.

### Related Topic

[About the BLUETOOTH\(R\) Function<BLUETOOTH equipped models>](#)[Communicating with Another BLUETOOTH\(R\) Device such as a Mouse<BLUETOOTH equipped models>](#)[Stopping BLUETOOTH\(R\) Communications<BLUETOOTH equipped models>](#)[Notes on Using the BLUETOOTH\(R\) Function<BLUETOOTH equipped models>](#)[Notes on Using the Wireless LAN Function](#)

[> Troubleshooting](#)**How to Use**[Parts Description](#)[Setup](#)[Network / Internet](#)[Connections](#)[Settings](#)[View](#)[Playback](#)[Backup / Recovery](#)[Security](#)[Other Operations](#)[Notifications](#)[MONITOR Function](#)

## About the BLUETOOTH(R) Function <BLUETOOTH equipped models>

You can establish wireless communications between your VAIO computer and other BLUETOOTH devices, such as another computer, a smartphone, a mobile phone, a headset, or a mouse.

You can transfer data between these devices without cables at a range of up to 33 feet / 10 meters in an open area.



One BLUETOOTH device can connect with up to seven devices via wireless network to exchange data.

When a device requires connection to another device, it sends out an inquiry to neighboring BLUETOOTH devices. If any device responds to the inquiry, the two devices can connect with each other.

### Related Topic

[Communicating with Another BLUETOOTH\(R\) Device such as a Mouse<BLUETOOTH equipped models>](#)

[Stopping BLUETOOTH\(R\) Communications<BLUETOOTH equipped models>](#)

[Notes on Using the BLUETOOTH\(R\) Function<BLUETOOTH equipped models>](#)



[About BLUETOOTH\(R\) Security<BLUETOOTH equipped models>](#)

[▶ Troubleshooting](#)**How to Use**[Parts Description](#)[Setup](#)[Network / Internet](#)[Connections](#)[Settings](#)[View](#)[Playback](#)[Backup / Recovery](#)[Security](#)[Other Operations](#)[Notifications](#)[MONITOR Function](#)

## Communicating with Another BLUETOOTH(R) Device such as a Mouse <BLUETOOTH equipped models>

You can connect BLUETOOTH devices to your VAIO computer.

For details on BLUETOOTH communication, see About the BLUETOOTH Function <BLUETOOTH equipped models>. [\[Details\]](#)

1. Click , All Programs, and VAIO Smart Network or click  (the VAIO Smart Network icon) in the desktop notification area.
2. Make sure that the switch next to BLUETOOTH is toggled to On.  
If it is set to Off, click it to toggle to On.

**Hint**

- If your VAIO computer is compliant with BLUETOOTH high speed technology and you intend to use it for high-speed communications, toggle the switch next to Wireless LAN or Wi-Fi to On, too.
  - Make sure that the WIRELESS indicator light on your VAIO computer is on.
3. Click , (Start) and Devices and Printers.
  4. When connecting a BLUETOOTH mouse, turn it on and press the button to connect the mouse.  
**Hint**
    - Refer to the manual that came with your BLUETOOTH device for the procedure to have the device ready for connection.
  5. Click Add a device.  
Your VAIO computer searches for devices and displays a device list. Follow the on-screen instructions to register your device.

**Note**

- Depending on the BLUETOOTH device, it may take some time for your VAIO computer to find the device. If your device does not appear in the list, repeat the procedure to have the device ready for connection (for example, pressing the button for connection).
- Depending on the BLUETOOTH device, the procedure to establish connection may vary. Refer to the manual that came with the device for the procedure.

**Hint**

- To connect a BLUETOOTH mouse, select it from the device list and click the Next button. If the Select a pairing option window appears, select Pair without using a code and click the Next button. Click Close with the mouse you selected to close the window.
- For details on the operations, click , (Start) and Help and Support to open Windows Help and Support, and then enter "BLUETOOTH" in the search box.
- A window appears for passkey input if a BLUETOOTH device is requesting authentication to establish connection. Follow the on-screen instructions to share the passkey between the BLUETOOTH device and your VAIO computer. If you do not wish to connect, click the Cancel button in the window.

A passkey is a secret number that is entered by a user to use for the authentication process to allow two BLUETOOTH devices to communicate with each other. Enter the same alphanumeric string (case-sensitive) for both devices to allow them to

communicate with each other. You can change the passkey every time you perform authentication, providing you enter the same passkey for both devices during the authentication process. For details on the passkey of a BLUETOOTH device, refer to the manual that came with the device. If no BLUETOOTH passkey is entered for a certain time, the connection process will be terminated for security. In this case, try again.

---

#### Related Topic

[About the BLUETOOTH\(R\) Function<BLUETOOTH equipped models>](#)

[Stopping BLUETOOTH\(R\) Communications<BLUETOOTH equipped models>](#)

[Notes on Using the BLUETOOTH\(R\) Function<BLUETOOTH equipped models>](#)

[About BLUETOOTH\(R\) Security<BLUETOOTH equipped models>](#)

---

[▶ Troubleshooting](#)**How to Use**[Parts Description](#)[Setup](#)[Network / Internet](#)[Connections](#)[Settings](#)[View](#)[Playback](#)[Backup / Recovery](#)[Security](#)[Other Operations](#)[Notifications](#)[MONITOR Function](#)

## Notes on Using the BLUETOOTH(R) Function <BLUETOOTH equipped models>

Before using the BLUETOOTH function, read the following precautions for correct use.

- In some countries or regions, using the BLUETOOTH function may be restricted by the local regulations.
- The BLUETOOTH function may not work with some devices, depending on the manufacturer or the software version employed by the manufacturer. Check the system requirements of the BLUETOOTH device before purchasing.  
For information on BLUETOOTH devices, visit the VAIO Support website.  
Some BLUETOOTH devices require authentication (pairing) before establishing connection with another device. Perform the authentication process before connecting to such devices.
- BLUETOOTH devices work on the 2.4 GHz band, which is used by a variety of devices. BLUETOOTH devices use the technology to minimize radio interference from other devices that use the same band; however, radio interference may still cause slower communication speeds, reduce communication range, or in some cases, cause communication failure.
- Communication speed and range may vary depending on the following conditions:
  - Distance between communication devices
  - Existence of obstacles between devices
  - Ambient environment that includes existence of walls and materials of such walls
  - Device configuration
  - Software in use
  - Radio conditions
 Communications may be cut off depending on radio conditions.
- If your VAIO computer is compliant with BLUETOOTH high speed technology and you intend to use it for high-speed communications, enable both the wireless LAN and BLUETOOTH functions on the computer.
- Large files may occasionally be corrupted during continuous transfer due to limitations of the BLUETOOTH standard and electromagnetic interference in the environment.
- Connecting multiple BLUETOOTH devices to your VAIO computer may cause channel congestion, resulting in poor device performance. This is normal with BLUETOOTH technology and does not indicate a malfunction.
- Video and audio may not be synchronized if you play videos on your VAIO computer with audio output from a connected BLUETOOTH device. This is a frequent occurrence with BLUETOOTH technology and does not indicate a malfunction.
- All BLUETOOTH devices must be certified through the procedure stipulated by Bluetooth SIG to ensure that they are compliant with the BLUETOOTH standard. Even if the BLUETOOTH devices are compliant with the BLUETOOTH standard, individual device performance, specifications, and operation procedures may vary. Data exchange may not be possible in all situations.
- Not all BLUETOOTH devices are guaranteed of compatibility with your VAIO computer.
- If you urgently need to disable the BLUETOOTH function, turn off your VAIO computer.

---

**Related Topic**[About the BLUETOOTH\(R\) Function<BLUETOOTH equipped models>](#)[Communicating with Another BLUETOOTH\(R\) Device such as a Mouse<BLUETOOTH](#)

[equipped models>](#)

[Stopping BLUETOOTH\(R\) Communications<BLUETOOTH equipped models>](#)

[About BLUETOOTH\(R\) Security<BLUETOOTH equipped models>](#)

[Notes on Using the Wireless LAN Function](#)

---

[▶ Troubleshooting](#)

## How to Use

---

[Parts Description](#)

---

[Setup](#)

---

[Network / Internet](#)

---

[Connections](#)

---

[Settings](#)

---

[View](#)

---

[Playback](#)

---

[Backup / Recovery](#)

---

[Security](#)

---

[Other Operations](#)

---

[Notifications](#)

---

[MONITOR Function](#)

---

## Stopping BLUETOOTH(R) Communications <BLUETOOTH equipped models>

Stop BLUETOOTH communications using VAIO Smart Network.

1. Turn off the BLUETOOTH device that is communicating with your VAIO computer.
2. In the VAIO Smart Network window, click the switch next to BLUETOOTH to toggle it to Off.

### Hint

- When another wireless communication function is enabled in the VAIO Smart Network window, the WIRELESS indicator light on your VAIO computer stays on.

---

### Related Topic

[About the BLUETOOTH\(R\) Function<BLUETOOTH equipped models>](#)

[Communicating with Another BLUETOOTH\(R\) Device such as a Mouse<BLUETOOTH equipped models>](#)

[Notes on Using the BLUETOOTH\(R\) Function<BLUETOOTH equipped models>](#)

---



[▶ Troubleshooting](#)**How to Use**[Parts Description](#)[Setup](#)[Network / Internet](#)[Connections](#)[Settings](#)[View](#)[Playback](#)[Backup / Recovery](#)[Security](#)[Other Operations](#)[Notifications](#)[MONITOR Function](#)

## Connecting External Speakers or Headphones

You can connect external sound output devices (such as speakers or headphones) to your VAIO computer.

1. Connect external speakers to the headphones jack  [\[Details\]](#) with a speaker cable (not supplied).

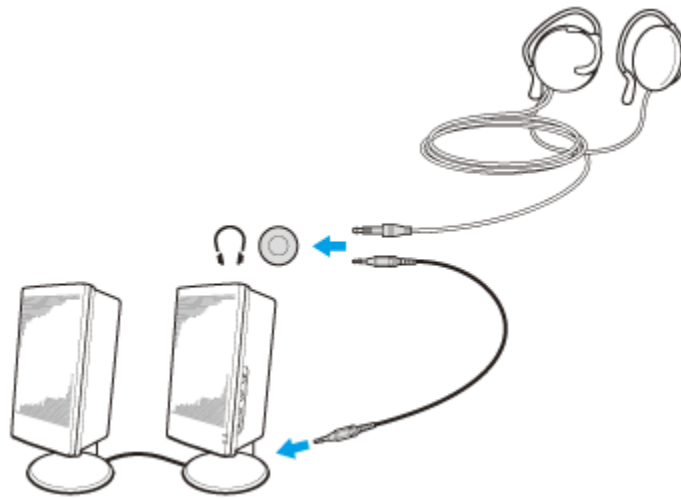
**Note**

- Turn down the volume of the speakers before turning them on.

**Hint**

- Refer to the manual that came with your speakers or headphones.

**Related Topic**[Adjusting the Speakers Volume](#)[Connecting an External Microphone](#)[Changing the Sound Output Device](#)[Adjusting the Volume in Windows](#)

[▶ Troubleshooting](#)

## How to Use

---

[Parts Description](#)

---

[Setup](#)

---

[Network / Internet](#)

---

[Connections](#)

---

[Settings](#)

---

[View](#)

---

[Playback](#)

---

[Backup / Recovery](#)

---

[Security](#)

---

[Other Operations](#)

---

[Notifications](#)

---

[MONITOR Function](#)

---

## About the Speakers Settings (MONITOR Function)

Sets the sound output.

When your VAIO computer is connected to an audio system such as an AV amplifier or a home theater system, set the sound output to audio system.

---

Related Topic

[Displaying the Menu Screen \(MONITOR Function\)](#)

---

[▶ Troubleshooting](#)**How to Use**

---

[Parts Description](#)

---

[Setup](#)

---

[Network / Internet](#)

---

[Connections](#)

---

[Settings](#)

---

[View](#)

---

[Playback](#)

---

[Backup / Recovery](#)

---

[Security](#)

---

[Other Operations](#)

---

[Notifications](#)

---

[MONITOR Function](#)

---

## Adjusting the Speakers Volume

You can change the volume level of the speakers and headphones.

**Note**

- The volume control buttons and muting button on the keyboard are available only while the PC is running. With the HDMI/VIDEO function activated, the buttons are disabled.

To adjust the volume using the volume control buttons on the keyboard

1. Press one of the volume control buttons on the keyboard.  
Press the + button to turn up the volume. Press the - button to turn it down.

**Hint**

- You can press one of the volume control buttons to turn on the volume when the volume is turned off.
- To adjust the volume with the HDMI/VIDEO function activated, use the VOL (Volume) buttons on the right side of your VAIO computer. [\[Details\]](#)

To use the muting button on the keyboard

1. Press the muting button on the keyboard.  
The volume of the speakers and headphones is turned off.  
Press the button again to turn on the volume.

---

**Related Topic**[Adjusting the Volume in Windows](#)[Adjusting the Microphone Volume](#)[Connecting External Speakers or Headphones](#)

---

[▶ Troubleshooting](#)

## How to Use

---

[Parts Description](#)

---

---

[Setup](#)

---

---

[Network / Internet](#)

---

---

[Connections](#)

---

---

[Settings](#)

---

---

[View](#)

---

---

[Playback](#)

---

---

[Backup / Recovery](#)

---

---

[Security](#)

---

---

[Other Operations](#)

---

---

[Notifications](#)

---

---



[MONITOR Function](#)

---

## Charging a USB Device

You can charge a USB device even while your VAIO computer is off, in Hibernate mode, or Sleep mode by enabling the USB charging settings.

The USB charging settings are disabled by default.

1. Click  (Start), All Programs, and VAIO Control Center.
2. Click Power Management and USB Charging Settings to enable the settings.
3. Connect a USB device to the USB port with the  mark printed around it.

If charging does not start even when you connect a USB device to the USB port that supports USB charging, disconnect and connect the device.

### Note

- Unless your VAIO computer is connected to an AC power source, USB charging does not work while the computer is off, in Hibernate mode, or Sleep mode.
- When the USB charging settings are enabled, you cannot use the remote wake-up function on the USB device connected to the USB port that supports USB charging.

[▶ Troubleshooting](#)**How to Use**[Parts Description](#)[Setup](#)[Network / Internet](#)[Connections](#)[Settings](#)[View](#)[Playback](#)[Backup / Recovery](#)[Security](#)[Other Operations](#)[Notifications](#)[MONITOR Function](#)

## Connecting a USB Device

You can connect a Universal Serial Bus (USB) device such as a mouse, floppy disk drive, speaker or printer to your VAIO computer. Installation of the device driver software supplied with the USB device may be required when connecting. Refer to the manual that came with the device for more information.

1. Choose the USB port (1) you prefer to use.
2. Plug the USB device cable (2) into the USB port.

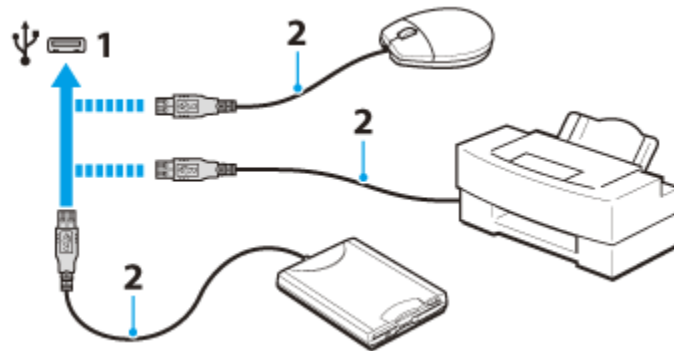
**Note**

- You may need to install the driver software supplied with your USB device before use. Refer to the manual that came with the USB device for more information.
- In order to print documents, be sure the USB printer is compatible with your version of Windows.
- Before disconnecting USB speakers from your VAIO computer, stop DVD or music playback or turn off the computer. If you disconnect the USB speakers during playback, it may cause a malfunction.  
For information on how to remove a USB device, refer to the manual that came with the device.
- To protect your VAIO computer and/or USB devices from damage, observe the following:
  - When moving your VAIO computer with USB devices connected, avoid exposing the USB ports to shock or impact.
  - Do not put your VAIO computer in a bag or carrying case with USB devices connected.

**Hint**

- The USB ports on your VAIO computer are compliant with the USB 2.0 standard and USB 3.0 standard. USB ports that are compliant with the USB 3.0 standard are identifiable by their blue color.
- In addition to the USB 2.0 standard transfer modes, the USB 3.0 standard specifies the following transfer mode:
  - SuperSpeed: Transfer rate of 5 Gbps.

**Related Topic**[Connecting an External DVD Drive](#)



[▶ Troubleshooting](#)

## How to Use

---

[Parts Description](#)

---

---

[Setup](#)

---

---

[Network / Internet](#)

---

---

[Connections](#)

---

---

[Settings](#)

---

---

[View](#)

---

---

[Playback](#)

---

---

[Backup / Recovery](#)

---

---

[Security](#)

---

---

[Other Operations](#)

---

---

[Notifications](#)

---

---

[MONITOR Function](#)

---

## About i.LINK

i.LINK is a Serial Digital Interface that transfers digital video/audio signals bi-directionally between i.LINK devices, and allows you to operate other i.LINK devices.

You can operate another i.LINK device directly or indirectly, so device connection order is not concern.

However, some i.LINK devices may not communicate with each other, depending on their specification.

### Notes on connecting i.LINK devices

- The i.LINK port on your VAIO computer does not supply power to an external device. If the external device requires external power, be sure to connect it to a power source.
- The i.LINK port supports transfer rates up to 400 Mbps. However, the actual transfer rate depends on the transfer rate of the external device.
- The optional i.LINK cables may not be available in some countries or regions.
- An i.LINK connection with other compatible devices is not fully guaranteed.
- The i.LINK connection may not be available depending on the software applications, operating system, and i.LINK-compatible devices you use. See the manual that came with your software for more information.
- Check the working conditions and operating system compatibility of i.LINK-compatible PC peripherals (for example, an HDD or a CD-RW drive) before you connect them to your computer.

---

### Related Topic

[Connecting a Digital Video Camcorder with an i.LINK Cable](#)

---

[▶ Troubleshooting](#)

## How to Use

[Parts Description](#)[Setup](#)[Network / Internet](#)[Connections](#)[Settings](#)[View](#)[Playback](#)[Backup / Recovery](#)[Security](#)[Other Operations](#)[Notifications](#)[MONITOR Function](#)

## Connecting a Digital Video Camcorder with an i.LINK Cable

You can connect an i.LINK device such as a digital video camcorder, to the i.LINK port on your VAIO computer.

The procedure to establish an i.LINK connection and import images from a digital video camcorder varies depending on the i.LINK device or software application. Refer to the manual that came with your i.LINK device for more information.

1. Connect your VAIO computer and digital video camcorder with an i.LINK cable (not supplied).

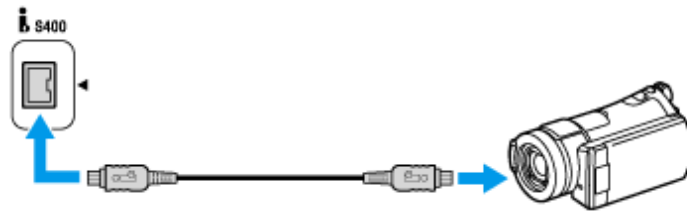

### Note

- The i.LINK port on your VAIO computer does not supply power to the i.LINK device. Therefore, a connected i.LINK device that requires external power may not work properly.
- The i.LINK port supports a transfer rate of up to 400 Mbps. However, the actual transfer rate will depend on the transfer rate of the external device.
- The optional i.LINK cables may not be available in some countries or regions.

### Related Topic

[About i.LINK](#)



[▶ Troubleshooting](#)**How to Use**

---

[Parts Description](#)

---

[Setup](#)

---

[Network / Internet](#)

---

[Connections](#)

---

[Settings](#)

---

[View](#)

---

[Playback](#)

---

[Backup / Recovery](#)

---

[Security](#)

---

[Other Operations](#)

---

[Notifications](#)

---

[MONITOR Function](#)

---

## About the MTS Audio Settings (MONITOR Function) <TV tuner board installed models>

Sets audio settings for analog programs.

---

### Related Topic

[Displaying the Menu Screen \(MONITOR Function\)](#)

---

[▶ Troubleshooting](#)

## How to Use

---

[Parts Description](#)

---

[Setup](#)

---

[Network / Internet](#)

---

[Connections](#)

---

[Settings](#)

---

[View](#)

---

[Playback](#)

---

[Backup / Recovery](#)

---

[Security](#)

---

[Other Operations](#)

---

[Notifications](#)

---

[MONITOR Function](#)

---

## About the Sound Adjustments / Sound Settings (MONITOR Function)

This topic explains sound adjustments.

This setting allows you to use the following functions/features.

- Adjusts higher and lower-pitched-sounds.
- Provides surround effects for an input source.
- Virtually generates three-dimensional sound.
- Reproduces clear sound.
- Keeps volume level constant across all contents.
- Adjusts the current volume level relative to other inputs.

---

### Related Topic

[Displaying the Menu Screen \(MONITOR Function\)](#)

---

[▶ Troubleshooting](#)

## How to Use

---

[Parts Description](#)

---

[Setup](#)

---

[Network / Internet](#)

---

[Connections](#)

---

[Settings](#)

---

[View](#)

---

[Playback](#)

---

[Backup / Recovery](#)

---

[Security](#)

---

[Other Operations](#)

---

[Notifications](#)

---

[MONITOR Function](#)

---

## Adjusting the Microphone Volume

You can adjust the volume level of the microphone.

1. Click  (Start) and Control Panel.
2. Click Hardware and Sound.
3. Click Sound.
4. Click the Recording tab.
5. Double-click the microphone icon.
6. Click the Levels tab in the Microphone Properties window.
7. Move a slider in Microphone right and left to your desired volume level.  
If the microphone volume is still not loud enough even at the maximum volume level, move a slider in Microphone Boost right and left to adjust the volume level.
8. Click OK.

---

### Related Topic

[Connecting an External Microphone](#)[Adjusting the Speakers Volume](#)[Adjusting the Volume in Windows](#)

---

[▶ Troubleshooting](#)

## How to Use

---

[Parts Description](#)

---

[Setup](#)

---

[Network / Internet](#)

---

[Connections](#)

---

[Settings](#)

---

[View](#)

---

[Playback](#)

---

[Backup / Recovery](#)

---

[Security](#)

---

[Other Operations](#)

---

[Notifications](#)

---

[MONITOR Function](#)

---

## Adjusting the Volume in Windows

You can adjust the volume on each software application from the Control Panel window.

1. Click  (Start) and Control Panel.
2. Click Hardware and Sound.
3. Click Adjust system volume under Sound.
4. Move a slider in Device up and down to your desired volume level.

When the volume is turned off () , click  (Deactivate muting) to turn on the volume (). When the volume has been minimized, turn the volume up with the slider.

### To turn off the Windows startup sound

1. Click  (Start) and Control Panel.
2. Click Hardware and Sound.
3. Click Sound.
4. Click the Sounds tab.
5. Click to clear the Play Windows Startup sound check box.
6. Click OK.

---

### Related Topic

[Adjusting the Speakers Volume](#)[Adjusting the Microphone Volume](#)[Connecting External Speakers or Headphones](#)

---

[▶ Troubleshooting](#)**How to Use**[Parts Description](#)[Setup](#)[Network / Internet](#)[Connections](#)[Settings](#)[View](#)[Playback](#)[Backup / Recovery](#)[Security](#)[Other Operations](#)[Notifications](#)[MONITOR Function](#)

## Connecting an External DVD Drive

Connect an external DVD drive or hard disk drive to a USB port on your VAIO computer.

1. Plug the power cord of your external drive into an AC outlet (1).
2. Plug one end of a USB cable (3) (not supplied) into the USB port (2), and the other end to the external drive. [\[Details\]](#)

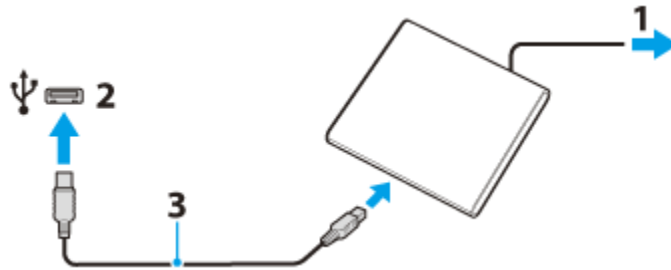
**Note**

- Be sure to connect an external drive to a power source with an AC adapter (if supplied).

**Hint**

- You may need to install a software driver depending on the external drive you use. In addition, procedures to connect and use an external drive vary depending on the drive you use. Refer to the manual that came with your external drive for more information.

**Related Topic**[Connecting a USB Device](#)

[> Troubleshooting](#)**How to Use**

---

[Parts Description](#)

---

[Setup](#)

---

[Network / Internet](#)

---

[Connections](#)

---

[Settings](#)

---

[View](#)

---

[Playback](#)

---

[Backup / Recovery](#)

---

[Security](#)

---

[Other Operations](#)

---

[Notifications](#)

---

[MONITOR Function](#)

---

## About Region Codes <Optical disc drive equipped models>

The following is a list of DVD region codes indicating playable regions of DVD media. You can check the region codes of DVD media sold in the following countries or regions.

1. USA, Canada
  2. Europe, Middle East, South Africa, Japan
  3. Southeast Asia, Taiwan, South Korea, Hong Kong
  4. Central America, South America, Mexico, Australia, New Zealand
  5. North Africa, Asia, Russia, Ukraine, Belarus, India
  6. China
  7. Reserved for future use
  8. International aircraft, international cruise ship, international conference hall, etc.
- Region code indicators are labeled on the discs or packages to indicate in which region and on what type of player you can play the disc. If the region code indicates "all," you can play this disc in most regions of the world. If the region code for your residence area is different from the label, you cannot play the disc on your VAIO computer.

---

### Related Topic

[Supported Discs<Optical disc drive equipped models>](#)

---

[▶ Troubleshooting](#)**How to Use**[Parts Description](#)[Setup](#)[Network / Internet](#)[Connections](#)[Settings](#)[View](#)[Playback](#)[Backup / Recovery](#)[Security](#)[Other Operations](#)[Notifications](#)[MONITOR Function](#)

## Handling Discs <Optical disc drive equipped models>

Read the following to protect data stored on discs and take proper care of discs.

- Be sure to hold the disc by its edges and central hole without touching the recording surface (playing surface), as shown below. Fingerprints and dust on the surface of a disc may cause a read or write error. Be sure to keep the disc clean.



- Sony assumes no liability for any problems and damages to discs arising out of adhesive labels affixed to discs. Refer to the manual carefully that came with the label software or label paper, and use the labels under your responsibility.



To take proper care of discs

- For normal cleaning, hold the disc by its edges and use a soft cloth to wipe the surface from the center out, as shown below.



- If the disc is badly soiled, moisten a soft cloth with water, wring it out well, and use it to wipe the surface of the disc. Wipe off any remaining moisture with a dry soft cloth.
- Do not use solvents such as benzine, thinner, commercially available cleaners, or anti-static spray which may cause damage to the disc.

[▶ Troubleshooting](#)**How to Use**[Parts Description](#)[Setup](#)[Network / Internet](#)[Connections](#)[Settings](#)[View](#)[Playback](#)[Backup / Recovery](#)[Security](#)[Other Operations](#)[Notifications](#)[MONITOR Function](#)

## Inserting/Removing a Disc <Optical disc drive equipped models>

Insert/remove a disc to/from your VAIO computer that is turned on.

**Note**

- Insert/remove a disc to/from your VAIO computer when the PC is running. You cannot insert/remove the disc when you are using the function available without running the PC, such as the HDMI/VIDEO input function.

### To insert a disc

1. Insert a disc into the optical disc drive slot.

When the optical disc drive has a vertical slot, insert a disc with the label side facing toward you.



When the optical disc drive has a horizontal slot, insert a disc with the label side facing upward.

**Note**

- Slide the disc straight into the slot without applying excessive pressure to the disc.
- Make sure there is no disc inserted in the optical disc drive before inserting a disc into the slot.

### To remove a disc

1. Press the drive eject button.  
The disc slides out.

**Note**

- Do not forcibly pull out the disc from the optical disc drive before it completely slides out.

### Related Topic

[Supported Discs<Optical disc drive equipped models>](#)[About Region Codes<Optical disc drive equipped models>](#)



[▶ Troubleshooting](#)**How to Use**

---

[Parts Description](#)

---

[Setup](#)

---

[Network / Internet](#)

---

[Connections](#)

---

[Settings](#)

---

[View](#)

---

[Playback](#)

---

[Backup / Recovery](#)

---

[Security](#)

---

[Other Operations](#)

---

[Notifications](#)

---

[MONITOR Function](#)

---

## Notes on Using Discs <Optical disc drive equipped models>

Observe the following notes when using discs on your VAIO computer.

### Notes on playing discs

- Depending on system environment, you may find sound interruptions and/or dropped frames during DVD/BD/AVCHD playback. In addition, some discs may not be able to play on your VAIO computer.
- When you are playing discs:
  - The CPU load increases. Close all running software other than the playback software you are currently using to enjoy smoother playback.
  - Do not switch the display output between the computer screen and an external display.

### Notes on playing recorded discs on other players

- Some CD players may not be able to play audio CDs created with CD-R or CD-RW media.
- Some DVD players may not be able to play DVDs created with DVD+R DL, DVD-R DL, DVD+R, DVD+RW, DVD-R, DVD-RW, or DVD-RAM media.
- Blu-ray Disc recorders that support BD-RE Ver.1.0 cannot play BD-R or BD-RE media created with your VAIO computer. (Blu-ray Disc Drive with DVD SuperMulti equipped models)

### Tips for successful writing

- Do not plug or unplug cables, such as the AC adapter or the power cord while the optical disc drive is writing data to a disc.
- The writing process may take longer to complete than theoretically predicted because some software writes and verifies data simultaneously.
- Sony assumes no liability for any loss or damage of any kind arising out of writing failure.

[▶ Troubleshooting](#)**How to Use**[Parts Description](#)[Setup](#)[Network / Internet](#)[Connections](#)[Settings](#)[View](#)[Playback](#)[Backup / Recovery](#)[Security](#)[Other Operations](#)[Notifications](#)[MONITOR Function](#)

## Supported Discs <Optical disc drive equipped models>

This topic explains media types that are playable/recordable on your VAIO computer. The installed optical disc drive varies depending on the model you purchased. Check the specifications before use.

### For DVD SuperMulti Drive equipped models

The optical disc drive supports playback and/or recording of the following media.

#### Playback and recording

- CD-R/RW \*1
- DVD-R/RW
- DVD+R/RW
- DVD+R DL (Double Layer)
- DVD-R DL (Dual Layer)
- DVD-RAM \*2\*3

#### Playback only

- CD-ROM
- DVD-ROM

### For Blu-ray Disc(TM) Drive with DVD SuperMulti equipped models

The optical disc drive supports playback and/or recording of the following media.

#### Playback and recording

- CD-R/RW \*1
- DVD-R/RW
- DVD+R/RW
- DVD+R DL (Double Layer)
- DVD-R DL (Dual Layer)
- DVD-RAM \*2\*3
- BD-R/RE \*4\*5\*6

#### Playback only

- CD-ROM
- DVD-ROM
- BD-ROM

### For Blu-ray Disc(TM) ROM Drive with DVD SuperMulti equipped models

The optical disc drive supports playback and/or recording of the following media.

#### Playback and recording

- CD-R/RW \*1

- DVD-R/RW
- DVD+R/RW
- DVD+R DL (Double Layer)
- DVD-R DL (Dual Layer)
- DVD-RAM \*2\*3

#### Playback only

- CD-ROM
- DVD-ROM
- BD-ROM

\*1 Writing data to Ultra Speed CD-RW media is not supported.

\*2 The optical disc drive does not support the DVD-RAM cartridge. Use non-cartridge discs or discs with a removable cartridge.

\*3 Writing data to single-sided DVD-RAM media (2.6 GB) compliant with DVD-RAM Version 1.0 is not supported.

DVD-RAM Version 2.2/12X-SPEED DVD-RAM Revision 5.0 media are not supported.

\*4 BD-RE Disc media in Version 1.0 format and Blu-ray Disc media with a cartridge are not supported.

\*5 Writing data to BD-R Part1 Version 1.1/1.2/1.3 media (single-layer media with the capacity of 25 GB, dual-layer media with the capacity of 50 GB) and BD-RE Part1 Version 2.1 media (single-layer media with the capacity of 25 GB, dual-layer media with the capacity of 50 GB) is supported.

\*6 BDXL(TM) media are not supported.

#### Note

- Your optical disc drive may not support writing or playback of some types of media.
- Your optical disc drive does not support 8 cm disc reading/writing and an 8 cm disc adapter.
- Your optical disc drive supports only circular discs. Do not use discs in any other shape (star, heart, card, etc.) or damaged discs, as it may cause your VAIO computer to malfunction.
- DVD-Video format data can be written to DVD+R (single layer or dual layer), DVD+RW/DVD-R (single layer or dual layer), and DVD-RW media. DVD-Video Recording format data can be written to DVD-R (single layer or dual layer), DVD-RW, and DVD-RAM media. Writable media differ depending on the disc burning software you use. Refer to the help file included with the software for more information.
- It is recommended that you use Sony branded media: DVD+R, DVD+RW, DVD-R, DVD-RW, CD-R, CD-RW, BD-R, or BD-RE.
- You cannot write data to DVD-RW media (6x writing) unless your optical disc drive supports at least 6x writing for DVD-RW media.
- You cannot write data to DVD+RW media (8x writing) unless your optical disc drive supports at least 8x writing for DVD+RW media.
- Your VAIO computer is designed to playback discs that conform to the Compact Disc (CD) standard. DualDiscs and some music discs encoded with copyright protection technologies do not conform to the CD standard. Therefore, these discs may not be compatible with the computer.
- When you buy pre-recorded or blank discs for use with your VAIO computer, be sure to read the notices on the disc package carefully to check both playback and recording compatibility with your computer's optical disc drives. Sony does NOT guarantee the compatibility of VAIO optical disc drives with discs that are not compliant with the official "CD," "DVD," or "Blu-ray Disc" standard. USING NON-COMPLIANT DISCS CAN CAUSE FATAL DAMAGE TO YOUR VAIO COMPUTER OR CREATE SOFTWARE CONFLICTS AND CAUSE SYSTEM HANGING.

For inquiries about disc formats, contact the individual publisher of the pre-recorded disc or the manufacturer of the recordable disc.

Your VAIO computer needs to be connected to the Internet to play DVD-RW, DVD-RAM, and DVD-R (single layer or dual layer) media that are compliant with the Content Protection for Recordable Media (CPRM) standard.

- To record, edit, or play copyright protected content, Blu-ray Disc media employs the Advanced Access Content System (AACs) technology. To use Blu-ray Disc media continually, you need to update the AACs key.
- You can update the AACs key through the Internet. Follow a message displayed on recording, editing, or playback software you are using. Without updating the AACs key, you may become unable to record, edit, or play copyright protected content.  
To record, edit, or play content without copyright protection, you do not need to update the AACs key. You can update the AACs key for the Blu-ray Disc recording or playback software installed on your VAIO computer for five years after purchase. After that, we will inform you about the update on the support website.
- Region settings are required for some contents of DVD and BD-ROM Disc media. If the region setting on the optical disc drive does not match the region code on the disc, playback is not possible.
- Unless your external display is compliant with the High-bandwidth Digital Content Protection (HDCP) standard, you cannot play or view the contents of copyright protected Blu-ray Disc media through an HDMI connection.
- Some Blu-ray Disc content may restrict video output to standard definition or prohibit analog video output.

---

Related Topic

[About Region Codes<Optical disc drive equipped models>](#)

---

[▶ Troubleshooting](#)

## How to Use

---

[Parts Description](#)

---

[Setup](#)

---

[Network / Internet](#)

---

[Connections](#)

---

[Settings](#)

---

[View](#)

---

[Playback](#)

---

[Backup / Recovery](#)

---

[Security](#)

---

[Other Operations](#)

---

[Notifications](#)

---

[MONITOR Function](#)

---

## About Add Digital Channels (MONITOR Function) <TV tuner board installed models>

Adds digital channels.

Be sure to have the signal type option selected appropriately for the signal source.

---

### Related Topic

[Displaying the Menu Screen \(MONITOR Function\)](#)

---

[▶ Troubleshooting](#)

## How to Use

---

[Parts Description](#)

---

[Setup](#)

---

[Network / Internet](#)

---

[Connections](#)

---

[Settings](#)

---

[View](#)

---

[Playback](#)

---

[Backup / Recovery](#)

---

[Security](#)

---

[Other Operations](#)

---

[Notifications](#)

---

[MONITOR Function](#)

---

## About Auto Program (MONITOR Function) <TV tuner board installed models>

Automatically scans for all available channels and stores them in the TV.

You can run Auto Program after moving to a new residence, changing service providers, or to search for newly launched channels.

---

### Related Topic

[Displaying the Menu Screen \(MONITOR Function\)](#)

---

[▶ Troubleshooting](#)

## How to Use

---

[Parts Description](#)

---

[Setup](#)

---

[Network / Internet](#)

---

[Connections](#)

---

[Settings](#)

---

[View](#)

---

[Playback](#)

---

[Backup / Recovery](#)

---

[Security](#)

---

[Other Operations](#)

---

[Notifications](#)

---

[MONITOR Function](#)

---

## About Edit Channel Labels (MONITOR Function) <TV tuner board installed models>

Edit channel labels to your preference.

---

Related Topic

[Displaying the Menu Screen \(MONITOR Function\)](#)

---

[▶ Troubleshooting](#)**How to Use**

---

[Parts Description](#)

---

[Setup](#)

---

[Network / Internet](#)

---

[Connections](#)

---

[Settings](#)

---

[View](#)

---

[Playback](#)

---

[Backup / Recovery](#)

---

[Security](#)

---

[Other Operations](#)

---

[Notifications](#)

---

[MONITOR Function](#)

---

## About Show/Hide Channels (MONITOR Function) <TV tuner board installed models>

Shows or hides channels when you surf with CH +/- or in the TV channel list.

---

### Related Topic

[Displaying the Menu Screen \(MONITOR Function\)](#)

---



[▶ Troubleshooting](#)**How to Use**

---

[Parts Description](#)

---

[Setup](#)

---

[Network / Internet](#)

---

[Connections](#)

---

[Settings](#)

---

[View](#)

---

[Playback](#)

---

[Backup / Recovery](#)

---

[Security](#)

---

[Other Operations](#)

---

[Notifications](#)

---

[MONITOR Function](#)

---

## About TV Initial Setup (MONITOR Function) <TV tuner board installed models>

Runs the initial setup that appeared when you first connected the TV.  
This setting is useful if you change settings after moving to a new residence.

---

### Related Topic

[Displaying the Menu Screen \(MONITOR Function\)](#)

---

[▶ Troubleshooting](#)**How to Use**

---

[Parts Description](#)

---

[Setup](#)

---

[Network / Internet](#)

---

[Connections](#)

---

[Settings](#)

---

[View](#)

---

[Playback](#)

---

[Backup / Recovery](#)

---

[Security](#)

---

[Other Operations](#)

---

[Notifications](#)

---

[MONITOR Function](#)

---

## About the Analog Fine Tune Settings (MONITOR Function) <TV tuner board installed models>

Allows you to fine-tune analog channels to adjust picture quality.

---

### Related Topic

[Displaying the Menu Screen \(MONITOR Function\)](#)

---

[▶ Troubleshooting](#)

## How to Use

---

[Parts Description](#)

---

[Setup](#)

---

[Network / Internet](#)

---

[Connections](#)

---

[Settings](#)

---

[View](#)

---

[Playback](#)

---

[Backup / Recovery](#)

---

[Security](#)

---

[Other Operations](#)

---

[Notifications](#)

---

[MONITOR Function](#)

---

## About the Parental Lock Settings (MONITOR Function) <TV tuner board installed models>

Sets an age restriction for viewing, or blocks specific channels.

To view any rated program you specify or any blocked channel, enter the correct password.

**Note**

- For the password, refer to Troubleshooting in this manual.

---

### Related Topic

[Displaying the Menu Screen \(MONITOR Function\)](#)

---

[▶ Troubleshooting](#)**How to Use**

---

[Parts Description](#)

---

[Setup](#)

---

[Network / Internet](#)

---

[Connections](#)

---

[Settings](#)

---

[View](#)

---

[Playback](#)

---

[Backup / Recovery](#)

---

[Security](#)

---

[Other Operations](#)

---

[Notifications](#)

---

[MONITOR Function](#)

---

## About the Signal Diagnostics Settings (MONITOR Function) <TV tuner board installed models>

Displays the diagnostics information for the current signal.

---

### Related Topic

[Displaying the Menu Screen \(MONITOR Function\)](#)

---

[▶ Troubleshooting](#)

## How to Use

[Parts Description](#)[Setup](#)[Network / Internet](#)[Connections](#)[Settings](#)[View](#)[Playback](#)[Backup / Recovery](#)[Security](#)[Other Operations](#)[Notifications](#)[MONITOR Function](#)

## Quitting TV <TV tuner board installed models>

Quit showing TV with your VAIO Computer.

1. Press the POWER button on the remote.

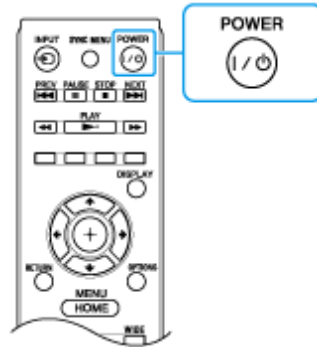

The TV function is turned off.

### Related Topic

[Watching TV with Your VAIO Computer<TV tuner board installed models>](#)



▶ [Troubleshooting](#)

**How to Use**

Parts Description

Setup

Network / Internet

Connections

Settings

View

Playback

Backup / Recovery

Security

Other Operations

Notifications

MONITOR Function

**Running TV Initial Setup**  
 <TV tuner board installed models>

To watch TV with your VAIO computer, you must first run TV Initial Setup. Use your VAIO computer's remote for this setting.

1. Check the antenna connection. [\[Details\]](#)
2. Press the HOME button on the remote.

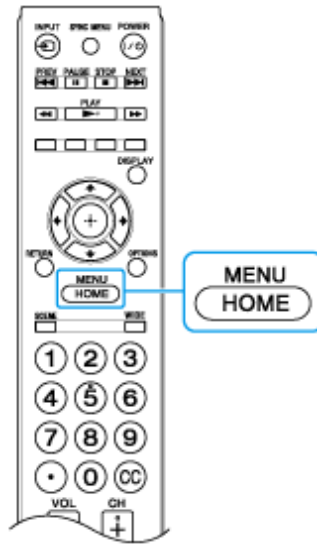

3. Select  (Settings), Preferences, and TV Initial Setup.
4. Follow the instructions on the screen.

Hint

- You can run the initial setup with the Initial Setup of TV display, which appears after finishing Windows setup.

Related Topic

[Watching TV with Your VAIO Computer<TV tuner board installed models>](#)

[▶ Troubleshooting](#)

## How to Use

[Parts Description](#)[Setup](#)[Network / Internet](#)[Connections](#)[Settings](#)[View](#)[Playback](#)[Backup / Recovery](#)[Security](#)[Other Operations](#)[Notifications](#)[MONITOR Function](#)

## Watching TV with Your VAIO Computer <TV tuner board installed models>

You can begin watching TV programs quickly without starting Windows.

1. Press the POWER button on the remote.

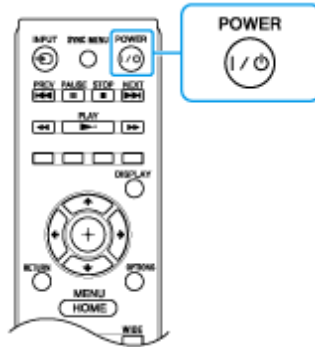

2. Press the INPUT button to select the TV input.
3. Press the CH buttons to select the TV program.

### Related Topic

[Quitting TV<TV tuner board installed models>](#)

[▶ Troubleshooting](#)

## How to Use

---

[Parts Description](#)

---

[Setup](#)

---

[Network / Internet](#)

---

[Connections](#)

---

[Settings](#)

---

[View](#)

---

[Playback](#)

---

[Backup / Recovery](#)

---

[Security](#)

---

[Other Operations](#)

---

[Notifications](#)

---

[MONITOR Function](#)

---

## Removing the Power-on Password

If power-on password input for booting up your VAIO computer is no longer necessary, follow these steps to remove the machine password and user password.

1. Turn on your VAIO computer and press the F2 key repeatedly until the VAIO logo disappears.  
Enter a password if it has already been set.  
The BIOS setup screen appears. If the screen does not appear, restart the computer and try again.
2. Press the **←** or **→** key to select the Security tab, select Set Machine Password or Set User Password, and then press the Enter key.  
The password entry screen appears.
3. Leave the Enter New Password and Confirm New Password fields blank and press the Enter key.
4. Press the **←** or **→** key to select the Exit tab, select Exit Setup, and then press the Enter key.  
At the confirmation prompt, press the Enter key.

---

### Related Topic

[Setting/Changing the Power-on Password](#)

[What should I do if I forget the power-on password to start my VAIO computer?](#)

---



[▶ Troubleshooting](#)**How to Use**[Parts Description](#)[Setup](#)[Network / Internet](#)[Connections](#)[Settings](#)[View](#)[Playback](#)[Backup / Recovery](#)[Security](#)[Other Operations](#)[Notifications](#)[MONITOR Function](#)

## Setting/Changing the Power-on Password

You can set a password (power-on password) for booting up your VAIO computer, using the BIOS function. Entry of the power-on password will be prompted after the VAIO logo appears to start the computer.

There are two types of passwords. Set the machine password first.

- **Machine password (for administrators):**  
Allows users with administrative rights to change all the setup options in the BIOS setup screen, as well as to start your VAIO computer.
- **User password (for users without administrative rights):**  
Allows standard users to change some of the BIOS setup options, as well as to start your VAIO computer. To set the user password, you must first set the machine password.

1. Turn on your VAIO computer and press the F2 key repeatedly until the VAIO logo disappears.  
Enter a password if it has already been set. If you intend to change the current password, enter the password which you want to change. (For example, enter your machine password to change a machine password.)  
The BIOS setup screen appears. If the screen does not appear, restart the computer and try again.
2. Press the **←** or **→** key to select the Security tab, select Set Machine Password or Set User Password, and then press the Enter key.  
The password entry screen appears.
3. Enter the password and press the Enter key.  
To change the password, enter the current password and a new password. The password can be set up to 32 alphanumeric characters long (including spaces) and it is case-sensitive.
4. Press the **↑** or **↓** key to select Password when Power On, press the Enter key, and select Enabled.
5. Press the **←** or **→** key to select the Exit tab, select Exit Setup, and then press the Enter key.
6. At the confirmation prompt, press the Enter key.

**Note**

- Be sure to write down the password to avoid forgetting it.
- If you forget the password, you cannot boot up your VAIO computer.
- You can reset the user password at the BIOS setup screen by entering the machine password.
- If you forget the machine password, the password must be reset by authorized Sony service/support center. (The reset fee will be charged.)

**Related Topic**[Removing the Power-on Password](#)[Creating/Changing/Removing Your Windows Password](#)[What should I do if I forget the power-on password to start my VAIO computer?](#)



[▶ Troubleshooting](#)**How to Use**

---

[Parts Description](#)

---

[Setup](#)

---

[Network / Internet](#)

---

[Connections](#)

---

[Settings](#)

---

[View](#)

---

[Playback](#)

---

[Backup / Recovery](#)

---

[Security](#)

---

[Other Operations](#)

---

[Notifications](#)

---

[MONITOR Function](#)

---

## Creating/Changing/Removing Your Windows Password

Setting the Windows password allows you to protect your VAIO computer from unauthorized access by making the user enter the password when the computer is turned on or returns from power saving mode to Normal mode.

Refer to Windows Help and Support for more information on the Windows password.

1. Click  (Start) and Control Panel.
2. Click User Accounts and Family Safety or User Accounts.
3. Click User Accounts.
4. Click Create a password for your account, Change your password, or Remove your password.
5. Follow the on-screen instructions to enter your password, and then press the Enter key.

**Note**

- Do not forget your password. Write down the password and keep it in a secure place.

**Hint**

- You can enter a hint in order to recall your password if you forget it. You can also create a password reset disc that can be used to create a new password. Refer to Windows Help and Support for more information on the Windows password.

---

**Related Topic**

[Setting/Changing the Power-on Password](#)

---

[▶ Troubleshooting](#)

## How to Use

---

[Parts Description](#)

---

[Setup](#)

---

[Network / Internet](#)

---

[Connections](#)

---

[Settings](#)

---

[View](#)

---

[Playback](#)

---

[Backup / Recovery](#)

---

[Security](#)

---

[Other Operations](#)

---

[Notifications](#)

---

[MONITOR Function](#)

---

## About Monitor Software version (MONITOR Function)

Displays the software version of your VAIO computer.

---

### Related Topic

[Displaying the Menu Screen \(MONITOR Function\)](#)

---

[▶ Troubleshooting](#)

## How to Use

[Parts Description](#)[Setup](#)[Network / Internet](#)[Connections](#)[Settings](#)[View](#)[Playback](#)[Backup / Recovery](#)[Security](#)[Other Operations](#)[Notifications](#)[MONITOR Function](#)

## Registering Your Favorite Items (Favorites)

By registering frequently used and recently viewed items, you can access them quickly from a list.

1. Press the HOME button on the remote, or the HOME button on the right side of your VAIO computer.

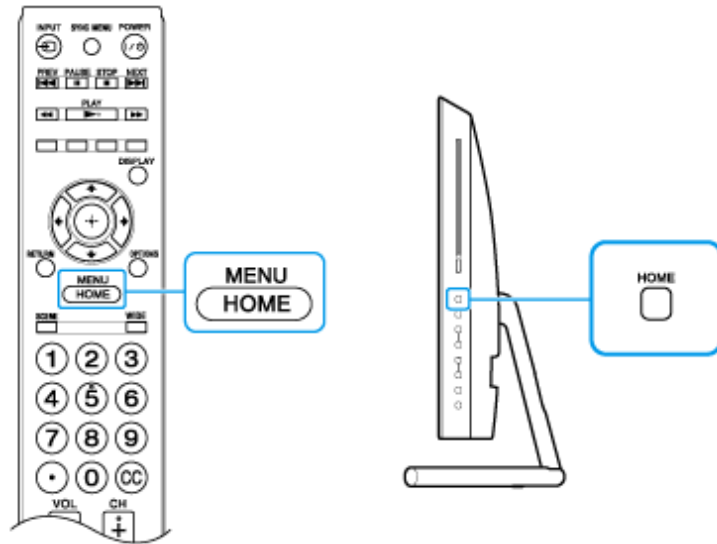

2. Display the desired item, or select one from the menu.
3. Press the OPTIONS button on the remote, or the OPTION button on the right side of your VAIO computer, then select Add to Favorites.

Related Topic

[Accessing Your Favorite Items](#)

[▶ Troubleshooting](#)**How to Use**[Parts Description](#)[Setup](#)[Network / Internet](#)[Connections](#)[Settings](#)[View](#)[Playback](#)[Backup / Recovery](#)[Security](#)[Other Operations](#)[Notifications](#)[MONITOR Function](#)

## Accessing Your Favorite Items

Access your favorite items registered on a list.

1. Press the HOME button on the remote, or the HOME button on the right side of your VAIO computer.

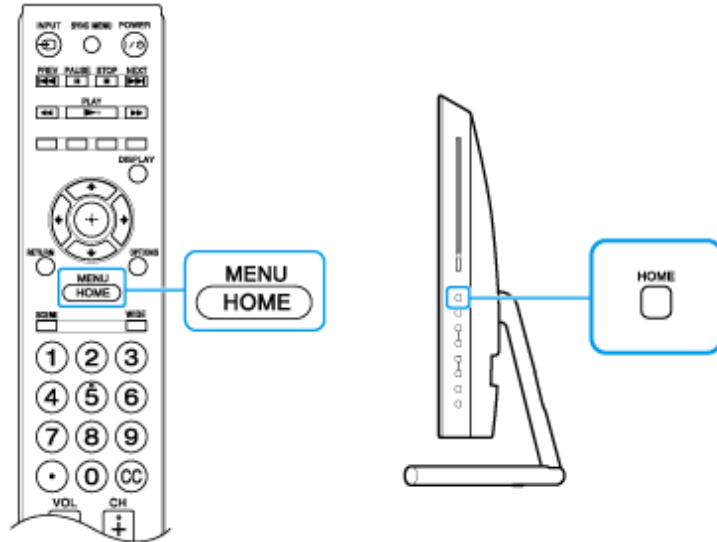

2. Select  (Favorites/History).
3. Select the desired item.

**Hint**

- A slideshow automatically starts when you select a folder of photos.

**Related Topic**[Registering Your Favorite Items \(Favorites\)](#)

[▶ Troubleshooting](#)**How to Use**[Parts Description](#)[Setup](#)[Network / Internet](#)[Connections](#)[Settings](#)[View](#)[Playback](#)[Backup / Recovery](#)[Security](#)[Other Operations](#)[Notifications](#)[MONITOR Function](#)

## Using the Built-in Camera <Built-in camera equipped models>

If your VAIO computer is equipped with a built-in camera, you can make a video call through the Internet using communication software, such as Windows Live Messenger. For detailed information on how to use the software, refer to the help file included with the software.

Adjust the tilt of the display to change the built-in camera angle. [\[Details\]](#)

The built-in camera indicator light is on while the built-in camera is in use.

**Hint**

- The software installed on your VAIO computer varies depending on the computer's configurations.

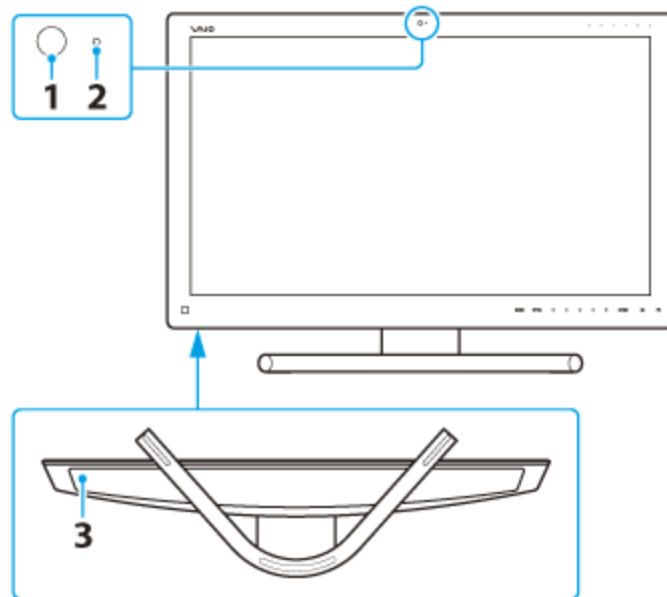

1. Built-in camera
2. Built-in camera indicator
3. Built-in microphone (monaural)

**To make a video call using Windows Live Messenger**

1. Click (Start), All Programs, and Windows Live Messenger.  
You need to sign in to Windows Live Messenger to make a video call.

**To display images from the built-in camera**

1. Click (Start), All Programs, ArcSoft Webcam Suite, and WebCam Companion 4.
2. Click Capture.

#### Hint

- If you cannot capture images properly, for example captured images are not displayed smoothly, click the current resolution of the capturing image in the upper right of the main window and lower the resolution.

---

#### Related Topic

[Notes on the Built-in Camera<Built-in camera equipped models>](#)

---



[▶ Troubleshooting](#)

## How to Use

---

[Parts Description](#)

---

[Setup](#)

---

[Network / Internet](#)

---

[Connections](#)

---

[Settings](#)

---

[View](#)

---

[Playback](#)

---

[Backup / Recovery](#)

---

[Security](#)

---

[Other Operations](#)

---

[Notifications](#)

---

[MONITOR Function](#)

---

## Notes on the Built-in Camera <Built-in camera equipped models>

- Do not scratch or soil the area on and around the built-in camera, as it may cause poor-quality images.
- Do not let direct sunlight enter the lens of the built-in camera regardless of your VAIO computer's power state, as it may cause the camera to malfunction.

### Care and cleaning of the built-in camera

If the area on and around the built-in camera is soiled, gently wipe it with a soft cloth, such as a lens cleaning cloth. Do not rub the area too hard, as it can be easily scratched.

---

### Related Topic

[Using the Built-in Camera<Built-in camera equipped models>](#)

---

[▶ Troubleshooting](#)

## How to Use

---

[Parts Description](#)

---

[Setup](#)

---

[Network / Internet](#)

---

[Connections](#)

---

[Settings](#)

---

[View](#)

---

[Playback](#)

---

[Backup / Recovery](#)

---

[Security](#)

---

[Other Operations](#)

---

[Notifications](#)

---

[MONITOR Function](#)

---

## Solving Common Problems with Your VAIO Computer

If you have any problem operating your VAIO computer, try these suggestions before contacting an authorized Sony service/support center or your local Sony dealer directly.

1. See other sections in this on-screen manual.
2. Start VAIO Care and perform necessary operations.
3. Visit the VAIO online support website and find necessary information.

---

### Related Topic

[Keeping Your VAIO Computer in Optimum Condition \(VAIO Care\)](#)

[Read This First](#)

[About Online Support Website](#)

---

[▶ Troubleshooting](#)**How to Use**[Parts Description](#)[Setup](#)[Network / Internet](#)[Connections](#)[Settings](#)[View](#)[Playback](#)[Backup / Recovery](#)[Security](#)[Other Operations](#)[Notifications](#)[MONITOR Function](#)

## Notes on Playing Photos / Music / Videos without Starting Windows

These notes explain how to play contents stored in connected USB device without starting Windows, and playable data formats.

- Your VAIO computer has been tested and found compatible with Sony branded “Memory Stick” of up to 16 GB for USB playback. Compatibility with any other media is not guaranteed.
- Refer to the manual that came with your USB device for more information.
- The MONITOR ONLY USB port of the computer supports the Hi-Speed USB standard. This port is unavailable for connection with a USB hub or equipment with a built-in USB hub.
- The MONITOR ONLY USB port of the computer supports FAT12, FAT16, FAT32 and exFAT file systems.
- USB playback of the following photo file formats is supported:
  - JPEG (files with the extension “.jpg” and MPF Baseline compliant)
  - JPEG (files with the extension “.jpg” and DCF 2.0 or Exif 2.21 compliant)
  - RAW (ARW/ARW 2.0 files with the extension “.arw”) (For preview only.)
  - MPO (files with the extension “.mpo”)
- Only panoramic JPEG files with the following horizontal/vertical dimensions can be scrolled. (If the JPEG file has been edited on a PC, etc., scroll may not be possible.)  
For horizontal scroll: 4912/1080, 7152/1080, 3424/1920, 4912/1920, 12416/1856, 8192/1856, 5536/2160, 3872/2160, 10480/4096  
For vertical scroll: 1080/4912, 1080/7152, 1920/3424, 1920/4912, 1856/12416, 1856/8192, 2160/5536, 2160/3872, 4096/10480
- USB playback of the following music file formats is supported. (Depending on the specifications, some files may be unsupported.)
  - MP3 (files with the extension “.mp3” that have not been copyrighted)
  - WAV (files with the extension “.wav”)
  - WMA (files with the extension “.wma”)
- USB playback of the following video file formats is supported. (Depending on the specifications, some files may be unsupported.)
  - AVCHD (files with the extension “.mts” or “.m2ts”)
  - MP4 (AVC) (files with the extension “.mp4”)
  - MP4 (MPEG4) (files with the extension “.mp4”)
  - MPEG1 (files with the extension “.mpg”)
  - MPEG2 (files with the extension “.mpg”)
  - WMV (files with the extension “.wmv” or “.asf”)
- A file of up to 2 GB is supported for playback.
- Video files are stored in the following folders, depending on their source, with the first file named as shown. The numerical part of the file name will increment for each new file added to the folder.
  - /AVCHD/BDMV/STREAM/00000.MTS
  - /PRIVATE/AVCHD/BDMV/STREAM/00000.MTS
  - /MP\_ROOT/100ANV01/MAHA0001.MP4
- Avoid losing your files by backing up all your media files stored on a USB device. Sony cannot accept responsibility for lost or damaged data stored on a USB device.

Related Topic

[Playing Photos / Music / Videos Stored in the Connecting USB Device without Starting Windows](#)

---

▶ Troubleshooting

How to Use

Parts Description

Setup

Network / Internet

Connections

Settings

View

Playback

Backup / Recovery

Security

Other Operations

Notifications

MONITOR Function

## Playing Photos / Music / Videos Stored in the Connecting USB Device without Starting Windows

Plays photos/music/videos on the screen by connecting a Sony digital still camera or other USB-compatible device.

It is not necessary to start Windows, so you can display photos in a short time.

1. Connect a USB device (2) to the MONITOR ONLY USB port (1) with a USB cable (not supplied) (A).

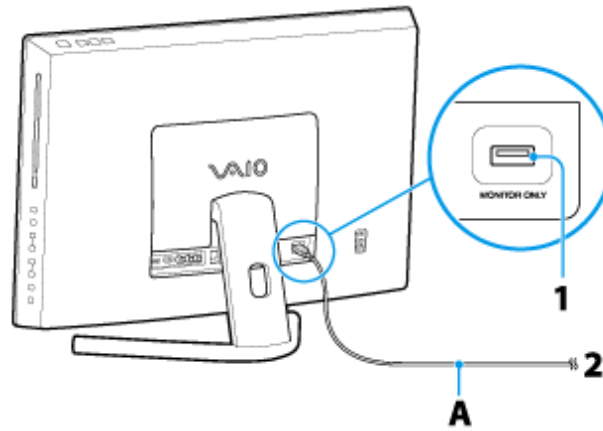

2. Press the HOME button on the remote, or the HOME button on the right side of your VAIO computer.

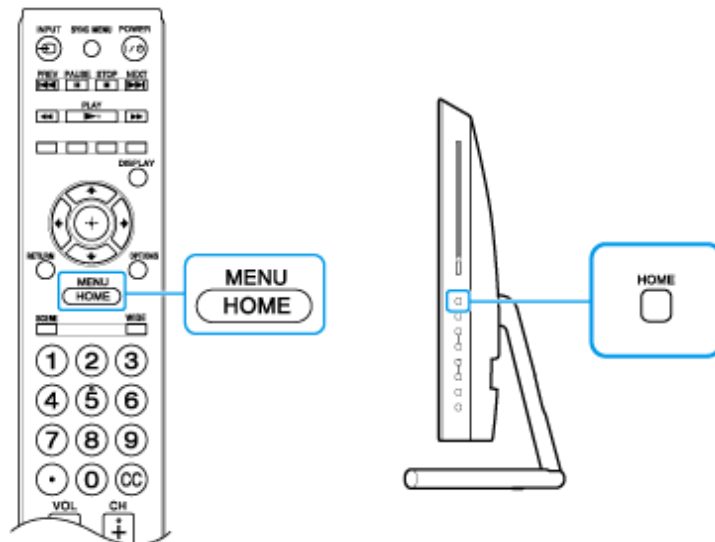

3. Select (Media), Photos/Music/Videos, and the desired USB device.
4. Select files or folders to play from the list.

Hint

- Photo playback automatically starts when you connect a USB storage device after turning on your VAIO computer, and slideshow or thumbnail view is selected in the USB Auto Start settings. Photo files must be stored in a folder under the DCIM folder for

automatic start of playback. Also, the folder name under the DCIM folder is required to be a combination of 3 numerals and 5 letters (can include “\_”), for example, 101MSDCF.

**Note**

- Some pictures may be expanded, so picture quality may deteriorate.
- Depending on the file or the settings, it may take time to display a still image.
- While accessing to a connected USB device, do not turn the computer or the USB device off, disconnect the USB cable, or remove media from the USB device. Otherwise data on the USB device may be damaged.
- When connecting a Sony digital camera to the computer with a USB cable, USB connection settings on your camera need to be set to Auto or Mass Storage mode.

---

Related Topic

[Notes on Playing Photos / Music / Videos without Starting Windows](#)

---

[▶ Troubleshooting](#)

## How to Use

---

[Parts Description](#)

---

[Setup](#)

---

[Network / Internet](#)

---

[Connections](#)

---

[Settings](#)

---

[View](#)

---

[Playback](#)

---

[Backup / Recovery](#)

---

[Security](#)

---

[Other Operations](#)

---

[Notifications](#)

---

[MONITOR Function](#)

---

## Checking the Volume of the Recovery Area

Your built-in storage device contains the recovery area where the data for the system recovery is stored. To check the volume of the recovery area, follow these steps:

1. Click  (Start), right-click Computer, and select Manage.
  2. Click Disk Management under Storage in the left pane.  
The volume of the recovery area and the total volume of the C: drive are displayed in the Disk 0 row in the center pane.
-

[▶ Troubleshooting](#)**How to Use**

---

[Parts Description](#)

---

[Setup](#)

---

[Network / Internet](#)

---

[Connections](#)

---

[Settings](#)

---

[View](#)

---

[Playback](#)

---

[Backup / Recovery](#)

---

[Security](#)

---

[Other Operations](#)

---

[Notifications](#)

---

[MONITOR Function](#)

---

## Creating Other Drives (Modifying Partitions)

Partitions are divided areas on your built-in storage device. Dividing the built-in storage device into more than one partition may have various advantages, such as separating the system files from your data files.

Your VAIO computer has only one partition (C: drive) as the factory default setting.\*

If you want to store data in another partition, such as D: drive, change the partition size and create a new partition.

There are two ways to create partitions: using Windows and creating during recovery.

For more information on how to create partitions, refer to Windows Help and Support or see [Creating Partitions during Recovery](#). [\[Details\]](#)

\* Some models may have D: drive as the factory default setting.

---

### Related Topic

[Creating Partitions in Windows](#)[Creating Partitions during Recovery](#)[Removing Recovery Contents to Free up Disk Space](#)

---



[▶ Troubleshooting](#)

## How to Use

---

[Parts Description](#)

---

---

[Setup](#)

---

---

[Network / Internet](#)

---

---

[Connections](#)

---

---

[Settings](#)

---

---

[View](#)

---

---

[Playback](#)

---

---

[Backup / Recovery](#)

---

---

[Security](#)

---

---

[Other Operations](#)

---

---

[Notifications](#)

---

---

[MONITOR Function](#)

---

## Creating Partitions during Recovery

This topic describes how to create partitions.

There are two ways to create partitions: using Windows and creating during recovery. To create partitions during recovery, follow these steps:

1. Press the ASSIST button while your VAIO computer is turned off to start VAIO Care Rescue.
2. Click Tools and Start advanced recovery wizard.  
Follow the on-screen instructions until a screen to select recovery type appears.
3. Click Custom recovery - Resize C: and create D: drive.
4. Enter the C: drive size and click Next.
5. Follow the on-screen instructions.

### Note

- If you create partitions during recovery, all data on your built-in storage device will be erased.
- If you reduce the partition size of the C: drive, Recovery Media creation may fail due to disk space shortage.

---

### Related Topic

[Creating Other Drives \(Modifying Partitions\)](#)

[Creating Partitions in Windows](#)

[Removing Recovery Contents to Free up Disk Space](#)

---

[▶ Troubleshooting](#)

## How to Use

---

[Parts Description](#)

---

[Setup](#)

---

[Network / Internet](#)

---

[Connections](#)

---

[Settings](#)

---

[View](#)

---

[Playback](#)

---

[Backup / Recovery](#)

---

[Security](#)

---

[Other Operations](#)

---

[Notifications](#)

---

[MONITOR Function](#)

---

## Creating Partitions in Windows

The Windows feature allows you to create a partition without recovering your VAIO computer system.

1. Click  (Start), Control Panel, System and Security, and Create and format hard disk partitions under Administrative Tools.

If the User Account Control window appears, click YES.

Hint

- If you are currently logged onto your VAIO computer as a standard user, you may be prompted to enter an administrator name and password.
2. Right-click the C: drive and select Shrink Volume.
  3. Enter the size of the partition to be created in Enter the amount of space to shrink in MB and click Shrink.
  4. Right-click Unallocated and select New Simple Volume.
  5. Follow the on-screen instructions.

---

### Related Topic

[Creating Other Drives \(Modifying Partitions\)](#)

[Creating Partitions during Recovery](#)

[Removing Recovery Contents to Free up Disk Space](#)

---

[▶ Troubleshooting](#)

## How to Use

[Parts Description](#)[Setup](#)[Network / Internet](#)[Connections](#)[Settings](#)[View](#)[Playback](#)[Backup / Recovery](#)[Security](#)[Other Operations](#)[Notifications](#)[MONITOR Function](#)

## Removing Recovery Contents to Free up Disk Space

Your built-in storage device contains the recovery area where the data for system recovery is stored. If your VAIO computer includes a solid state drive (SSD), you might want to minimize the recovery area by removing such data.

The above procedure involves system recovery. The applications and data you added on the storage device before removing the data for system recovery will all be lost.

Once you have removed the data for system recovery, you need the Recovery Media for later system recovery.

1. Create Recovery Media if you have not yet created it. [\[Details\]](#)
2. Insert the Recovery Media into the optical disc drive or connect a USB flash drive to the USB port on your VAIO computer while the computer is in Normal mode.

**Note**

- If your VAIO computer is equipped with the USB port that is compliant with the USB 2.0 standard, connect a USB device to the port.
3. Turn off your VAIO computer and turn it on once again.  
If you are using the USB flash drive, restart the computer and press the F11 key repeatedly until the VAIO logo disappears.
  4. Press the **↑** or **↓** key to select VAIO Care Rescue and press the Enter key.
  5. Click Tools and Start advanced recovery wizard.  
When the "Do you need to rescue data?" message appears, make a backup copy of your data, if needed.
  6. Follow the on-screen instructions until the Select recovery type window appears.
  7. Select Custom recovery - Remove recovery contents.
  8. Follow the on-screen instructions.

### Related Topic

[Creating Other Drives \(Modifying Partitions\)](#)[Creating Partitions in Windows](#)[Creating Partitions during Recovery](#)

[▶ Troubleshooting](#)**How to Use**[Parts Description](#)[Setup](#)[Network / Internet](#)[Connections](#)[Settings](#)[View](#)[Playback](#)[Backup / Recovery](#)[Security](#)[Other Operations](#)[Notifications](#)[MONITOR Function](#)

## About Recovery

Recovery is the process of restoring your VAIO computer back to its original factory condition.

There are two ways to recover the computer:

- From Recovery Media
- From the recovery area

### When do I have to perform recovery?

- If your VAIO computer has become unstable
- If your VAIO computer has been infected with a computer virus
- If your VAIO computer is experiencing problems which cannot be solved through troubleshooting
- If you have formatted the C: drive by mistake

### Which software should I use to maintain and recover my VAIO computer?

Use the following software.

#### VAIO Care

- Creating Recovery Media
- Checking your computer hardware

#### VAIO Care Rescue

- Rescuing (backing up) your data
- Recovering your VAIO computer
- Erasing all the data on your built-in storage device

#### Hint

- Refer to the help file included with VAIO Care and VAIO Care Rescue for more information.

### What is a recovery area?

The recovery area on the built-in storage device contains data for system and application recovery. Typically, you cannot modify or delete data in this area, however, there is commercially available software designed for this purpose.

### Why do I have to create Recovery Media?

Recovery Media are used to restore your VAIO computer back to its original factory condition. If Windows does not start and you have deleted the recovery area, you will need the Recovery Media to perform recovery.

Create the Recovery Media immediately after the computer is ready for use.

---

#### Related Topic

Creating Recovery Media  
Recovering from the Recovery Area  
Recovering from Recovery Media  
Notes on Recovery

---

© 2012 Sony Corporation

[▶ Troubleshooting](#)**How to Use**[Parts Description](#)[Setup](#)[Network / Internet](#)[Connections](#)[Settings](#)[View](#)[Playback](#)[Backup / Recovery](#)[Security](#)[Other Operations](#)[Notifications](#)[MONITOR Function](#)

## Creating Recovery Media

Follow the instructions below to create Recovery Media.

### To create Recovery Media

#### Hint

- You can use optical discs and a USB flash drive as Recovery Media. However, it is recommended that you use DVD-R or BD-R media, since you may accidentally delete the data on the USB flash drive.

The types of media your VAIO computer supports differ depending on the model you purchased.

- The types of media you can use for Recovery Media are DVD-R/BD-R/DVD+R/DVD+R DL/DVD-R DL/DVD+RW/DVD-RW/BD-RE/BD-R DL/BD-RE DL.

The types of media your VAIO computer supports, the number of necessary discs, and the capacity of the USB flash drive you need will be displayed during the Recovery Media creation process.

1. Connect your VAIO computer to the Internet, download and install the latest updates using VAIO Update.

2. Click (Start), All Programs, and VAIO Care.

If the User Account Control window appears, click Yes.

#### Hint

- If you are currently logged onto your VAIO computer as a standard user, you may be prompted to enter an administrator name and a password.

3. Click Advanced Tools, Restore and recovery, and Create Recovery Media.

4. Read the on-screen instructions carefully, and then click Next.

5. Follow the on-screen instructions.

#### Note

- It may take some time to display the current status of the procedure.
- Do not eject or disconnect the media while creating Recovery Media, as doing so may result in a failure of the process.
- Keep the Recovery Media in a secure place.

### Notes on creating Recovery Media

- Recovery Media is specific to your VAIO computer on which it was created.
- Create Recovery Media immediately after your VAIO computer is ready for use. In the following cases, you may not be able to recover the computer from the recovery area and Recovery Media will be necessary:
  - You have modified the recovery area with software designed for data modification.
  - You have installed an operating system different from the preinstalled operating system on the computer.
  - You have formatted your built-in storage device without using VAIO Care Rescue.
- Do not touch or soil the surface of the discs. Fingerprints or dust on the surface may cause read/write errors.

- Depending on the model you purchased, you may not be able to create Recovery Media using optical discs except DVD-R due to disk space shortage.
- Refer to the help file included with VAIO Care beforehand when you use a USB flash drive as Recovery Media.

---

Related Topic

[About Recovery](#)

[Recovering from the Recovery Area](#)

[Recovering from Recovery Media](#)

[Notes on Recovery](#)

---

[▶ Troubleshooting](#)

## How to Use

---

[Parts Description](#)

---

[Setup](#)

---

[Network / Internet](#)

---

[Connections](#)

---

[Settings](#)

---

[View](#)

---

[Playback](#)

---

[Backup / Recovery](#)

---

[Security](#)

---

[Other Operations](#)

---

[Notifications](#)

---

[MONITOR Function](#)

---

## Notes on Recovery

Read the following notes thoroughly before recovering your VAIO computer.

### Important notes on recovery

- Recovering your VAIO computer will delete all the data on the built-in storage device and restore all the settings to the original factory settings. Make sure you have a backup copy of your valuable data.
- Disconnect all peripherals from your VAIO computer except the power cord, the AC adapter, or devices required for recovery before recovering the computer.
- Do not stop the recovery process until the process is complete.
- If you have forgotten the password and cannot start the recovery process, contact an authorized Sony service/support center to reset it. A reset fee will be charged.

### Notes on software

- Recovering your VAIO computer can restore only the preinstalled software. The software that has been installed on your own or the data you have created since purchase cannot be restored. In addition, you cannot restore only Windows.
- Certain preinstalled software includes options that allow the applications to uninstall or install themselves. However, the software may not work properly on your VAIO computer if such options are used.
- Installing software to modify partition sizes may disable recovery or Recovery Media creation.

---

### Related Topic

[About Recovery](#)[Creating Recovery Media](#)[Recovering from the Recovery Area](#)[Recovering from Recovery Media](#)

---



[▶ Troubleshooting](#)**How to Use**[Parts Description](#)[Setup](#)[Network / Internet](#)[Connections](#)[Settings](#)[View](#)[Playback](#)[Backup / Recovery](#)[Security](#)[Other Operations](#)[Notifications](#)[MONITOR Function](#)

## Recovering from Recovery Media

If the recovery area data has been corrupted or erased, you can use Recovery Media to recover your VAIO computer. However, it takes longer time to recover using Recovery Media than using the recovery area.

1. Insert the disc into the optical disc drive or connect a USB flash drive to the USB port on your VAIO computer while the computer is in Normal mode.

**Note**

- If your VAIO computer is equipped with the USB port that is compliant with the USB 2.0 standard, connect a USB device to the port.
2. Turn off your VAIO computer and turn it on once again.  
If you are using the USB flash drive, press the F11 key repeatedly until the VAIO logo screen disappears.  
The Windows Boot Manager screen is displayed.  
If the screen does not appear, restart the computer and try again.
  3. Press the **↑** or **↓** key to select Start VAIO Care Rescue and press the Enter key.  
Hint
    - If the display language selection window appears, select your desired language and click OK.
  4. Select Start recovery wizard.
  5. Follow the on-screen instructions.

**Hint**

- To perform the custom recovery, select Tools and click Start advanced recovery wizard.
- If you cannot recover your VAIO computer using the USB flash drive, connect the drive to another USB port on the computer and try recovering the computer again.

**Related Topic**[About Recovery](#)[Creating Recovery Media](#)[Recovering from the Recovery Area](#)[Notes on Recovery](#)

[▶ Troubleshooting](#)

## How to Use

---

[Parts Description](#)

---

---

[Setup](#)

---

---

[Network / Internet](#)

---

---

[Connections](#)

---

---

[Settings](#)

---

---

[View](#)

---

---

[Playback](#)

---

---

[Backup / Recovery](#)

---

---

[Security](#)

---

---

[Other Operations](#)

---

---

[Notifications](#)

---

---

[MONITOR Function](#)

---

## Recovering from the Recovery Area

Recovery from the recovery area on the built-in storage device is faster than recovery using Recovery Media.

See Notes on Recovery [\[Details\]](#) before recovery.

1. Press the ASSIST button while your VAIO computer is off to start VAIO Care Rescue.

If the Edit Boot Options window is displayed, press the Enter key.  
VAIO Care Rescue starts.

Hint

- If the display language selection window appears, select your desired language and click OK.
2. Click Start recovery wizard.
  3. Follow the on-screen instructions.

Hint

- To perform the custom recovery, select Tools and click Start advanced recovery wizard.

---

Related Topic

[About Recovery](#)

[Creating Recovery Media](#)

[Recovering from Recovery Media](#)

[Notes on Recovery](#)

---

[▶ Troubleshooting](#)

## How to Use

---

[Parts Description](#)

---

[Setup](#)

---

[Network / Internet](#)

---

[Connections](#)

---

[Settings](#)

---

[View](#)

---

[Playback](#)

---

[Backup / Recovery](#)

---

[Security](#)

---

[Other Operations](#)

---

[Notifications](#)

---

[MONITOR Function](#)

---

## About Backup

The backup process creates a backup copy of your data stored on the built-in storage device and saves it to another location.

Due to unexpected events or computer viruses, you might lose various data stored on your built-in storage device. To restore the lost data, its backup copy is needed.

It is strongly recommended that you back up your data regularly.

If you can start Windows, back up and restore your data with the Windows feature.

To use the feature, click  (Start), Control Panel, System and Security, and Backup and Restore.

---

### Related Topic

[About Types of Backup](#)[Backing Up Your Data when You cannot Start Windows](#)[Restoring Your Data with VAIO Data Restore Tool](#)[Creating a Restore Point](#)[Restoring System Files Using the Restore Point when You cannot Start Windows](#)

---

[▶ Troubleshooting](#)

## How to Use

---

[Parts Description](#)

---

[Setup](#)

---

[Network / Internet](#)

---

[Connections](#)

---

[Settings](#)

---

[View](#)

---

[Playback](#)

---

[Backup / Recovery](#)

---

[Security](#)

---

[Other Operations](#)

---

[Notifications](#)

---

[MONITOR Function](#)

---

## About Types of Backup

You can use the Windows Backup and Restore feature to back up your valuable data. There are several types of backup to meet your needs, as described below.

### Backing up files

You can select and back up folders and files stored on your VAIO computer to a DVD or an external hard disk drive. For details on how to back up data, refer to Windows Help and Support.

### Backing up system images

You can create a backup copy of the whole system of your VAIO computer. If the built-in storage device or the computer ever stops working, you can use the system image to restore the computer as it was when backed up.

To create a system image, you need an optional hard disk drive formatted in NTFS format. You can also back up a system image to optical discs such as Blu-ray Disc or DVD disc. For details on how to create a system image, refer to Windows Help and Support.

### Restore point

After you install new software or change Windows settings, your VAIO computer may have some problems (such as slow response, unable to launch software, etc.).

You can create a restore point before such an installation or setting change to restore your system to an earlier point in time if it has a problem. For details on a restore point, see [Creating a Restore Point](#). [\[Details\]](#)

### Note

- We will not restore or compensate for any lost or damaged data under any circumstances including failure of your VAIO computer.
- Create Recovery Media soon after purchasing your VAIO computer. In the event that you cannot make a backup copy of your data with the Windows feature due to computer malfunctions, you can use the backup tool included in Recovery Media to back up your data.

For information on how to create Recovery Media, see [Creating Recovery Media](#). [\[Details\]](#)

### Hint

- If your VAIO computer is equipped with no disc drive, you need to connect an external device, such as an external hard disk drive or DVD drive, to the computer before backup, or you need to resize the partition of your C: drive and create another partition before backup. [\[Details\]](#)

---

### Related Topic

[About Backup](#)[Backing Up Your Data when You cannot Start Windows](#)[Restoring Your Data with VAIO Data Restore Tool](#)[Creating a Restore Point](#)[Restoring System Files Using the Restore Point when You cannot Start Windows](#)



[▶ Troubleshooting](#)**How to Use**[Parts Description](#)[Setup](#)[Network / Internet](#)[Connections](#)[Settings](#)[View](#)[Playback](#)[Backup / Recovery](#)[Security](#)[Other Operations](#)[Notifications](#)[MONITOR Function](#)

## Backing Up Your Data when You cannot Start Windows

If you cannot start Windows, back up your data with VAIO Care Rescue.

### To rescue your data

1. Press the ASSIST button while your VAIO computer is off to start VAIO Care Rescue.

#### Hint

- If the display language selection window appears, select your desired language and click OK.
2. Click Tools and Rescue Data.
  3. Follow the on-screen instructions.

#### Note

- If your VAIO computer is equipped with the USB port that is compliant with the USB 2.0 standard when you use a USB device to back up your data, connect the USB device to the port.

#### Hint

- Alternatively, you can start VAIO Care Rescue with Recovery Media. [\[Details\]](#)
- It is recommended that you select an external hard disk drive as a location to save rescued files if you select Custom rescue.

### Notes on using Rescue Data

- Handle rescued files with care to protect from unauthorized access.
- Disable the Windows hard disk drive encryption feature before using Rescue Data to back up and restore your data.  
However, rescued files which are not encrypted on the built-in storage device can be easily accessed by unauthorized users using Recovery Media and this software. Therefore, after using the software, be sure to set the power-on or hard disk password, enable the Windows hard disk drive encryption feature, and keep the Recovery Media in a secure place to protect rescued files from unauthorized access.
- To restore copyright protected data, such as music files organized by digital media playback software, use a backup tool specified by the software you used to import such data. Sony does not guarantee the playback compatibility of data which is not restored with the specified backup tool.
- Using Rescue Data does not guarantee to back up all the data on your built-in storage device.  
Sony assumes no liabilities for any loss of your data arising out of the backup process.
- Use the power cord or the AC adapter to power your VAIO computer while using this software.
- Rescued files may be divided into two or more files and saved in a specified location or renamed, depending on the location you select. Use VAIO Data Restore Tool to restore the rescued files. [\[Details\]](#)
- If an external hard disk drive or optical disc drive does not support the USB connection,

you need to install a software driver.

---

Related Topic

[About Backup](#)

[About Types of Backup](#)

[Restoring Your Data with VAIO Data Restore Tool](#)

[Creating a Restore Point](#)

[Restoring System Files Using the Restore Point when You cannot Start Windows](#)

---

[▶ Troubleshooting](#)

## How to Use

---

[Parts Description](#)

---

[Setup](#)

---

[Network / Internet](#)

---

[Connections](#)

---

[Settings](#)

---

[View](#)

---

[Playback](#)

---

[Backup / Recovery](#)

---

[Security](#)

---

[Other Operations](#)

---

[Notifications](#)

---

[MONITOR Function](#)

---

## Creating a Restore Point

A restore point enables you to restore your computer system files to a previous state, depending on when the restore point was created.

Typically, restore points are created automatically, for example when you install a software driver. However, we recommend that you create a new restore point manually, using Control Panel, before installing any software or software drivers on your VAIO computer. Refer to Windows Help and Support for information on creating a restore point.

---

### Related Topic

[About Backup](#)[About Types of Backup](#)[Backing Up Your Data when You cannot Start Windows](#)[Restoring Your Data with VAIO Data Restore Tool](#)[Restoring System Files Using the Restore Point when You cannot Start Windows](#)

---



[▶ Troubleshooting](#)

## How to Use

---

[Parts Description](#)

---

[Setup](#)

---

[Network / Internet](#)

---

[Connections](#)

---

[Settings](#)

---

[View](#)

---

[Playback](#)

---

[Backup / Recovery](#)

---

[Security](#)

---

[Other Operations](#)

---

[Notifications](#)



---

[MONITOR Function](#)

---

## Restoring System Files Using the Restore Point when You cannot Start Windows

When you cannot start Windows, follow these steps to restore computer system files.

1. Insert Recovery Media into the optical disc drive or connect a USB flash drive to the USB port on your VAIO computer while the computer is in Normal mode.
2. Turn off your VAIO computer and turn it on once again.  
If you are using the USB flash drive, press the F11 key repeatedly until the VAIO logo screen disappears.  
The Windows Boot Manager screen is displayed.
3. Press the  or  key to select Repair Windows 7 and press the Enter key.
4. Select a keyboard layout and click Next.  
If the appropriate keyboard layout is not selected, you may not be able to enter the password correctly.
5. Select your operating system and click Next.  
The system restore tool selection screen appears.
6. Click System Restore.  
The System Restore window appears.
7. Click Next.
8. Select a restore point and click Next.  
The confirmation window of the selected restore point appears.
9. Click Finish to confirm the restore point.  
Restart your VAIO computer if the window prompts you to restart the computer.

---

### Related Topic

[About Backup](#)[About Types of Backup](#)[Backing Up Your Data when You cannot Start Windows](#)[Restoring Your Data with VAIO Data Restore Tool](#)[Creating a Restore Point](#)

---

[▶ Troubleshooting](#)

## How to Use

[Parts Description](#)[Setup](#)[Network / Internet](#)[Connections](#)[Settings](#)[View](#)[Playback](#)[Backup / Recovery](#)[Security](#)[Other Operations](#)[Notifications](#)[MONITOR Function](#)

## Restoring Your Data with VAIO Data Restore Tool

If you backed up files previously using VAIO Care Rescue, use VAIO Data Restore Tool to restore these files.

For instructions on how to use the software, refer to the help file included with the software.

1. Click  (Start), All Programs, and VAIO Data Restore Tool.

The VAIO Data Restore Tool window appears.

2. Click Next.

If the User Account Control window appears, click Yes.

Hint

- If you are currently logged onto your VAIO computer as a standard user, you may be prompted to enter an administrator name and password.
3. Follow the on-screen instructions.

### Note

- To restore copyright protected data, such as music files organized by digital media playback software, use a backup tool specified by the software you used to import such data. Sony does not guarantee the playback compatibility of data which is not restored with the specified backup tool.

Hint

- If necessary, move the restored files to an original location.

---

### Related Topic

[About Backup](#)[About Types of Backup](#)[Backing Up Your Data when You cannot Start Windows](#)[Creating a Restore Point](#)[Restoring System Files Using the Restore Point when You cannot Start Windows](#)

[▶ Troubleshooting](#)

## How to Use

---

[Parts Description](#)

---

[Setup](#)

---

[Network / Internet](#)

---

[Connections](#)

---

[Settings](#)

---

[View](#)

---

[Playback](#)

---

[Backup / Recovery](#)

---

[Security](#)

---

[Other Operations](#)

---

[Notifications](#)

---

[MONITOR Function](#)

---

## About "Memory Stick"

"Memory Stick" is a compact, portable, and versatile IC recording media especially designed for exchanging and sharing digital data with compatible products, such as digital cameras and other devices. Because it is removable, it can be used for external data storage. For the latest information about "Memory Stick", visit <http://www.sony.net/memorycard/>.

---

### Related Topic

[Compatible "Memory Stick"](#)[Inserting/Removing "Memory Stick"](#)[Formatting "Memory Stick"](#)[Notes on Using "Memory Stick"](#)

---

[▶ Troubleshooting](#)**How to Use**[Parts Description](#)[Setup](#)[Network / Internet](#)[Connections](#)[Settings](#)[View](#)[Playback](#)[Backup / Recovery](#)[Security](#)[Other Operations](#)[Notifications](#)[MONITOR Function](#)

## Compatible “Memory Stick”

The “Memory Stick” slot on your VAIO computer can accommodate the following sizes and types of media:

- “Memory Stick Duo”
- “Memory Stick PRO Duo”
- “Memory Stick PRO-HG Duo”
- “Memory Stick Micro”

### About “MagicGate”

“MagicGate” refers to copyright protection technology developed by Sony. An authentication process is performed between the “MagicGate” compatible device and “Memory Stick” to check whether they can correctly store and play back data, and the data will be encrypted. The authentication is also performed before the data is played back, and only when they are properly authenticated, the data is decrypted and played back. The copyright protected data can be played back by authenticated devices only.

#### Note

- Your VAIO computer supports only Duo-size “Memory stick”, and does not support standard-size “Memory Stick”.
- Before using “Memory Stick Micro” (“M2”), be sure to insert it into an “M2” Duo adaptor. If you insert the media directly into the “Memory Stick Duo” slot without the adaptor, you may not be able to remove it from the slot.
- Your VAIO computer has been tested and found compatible with any Sony branded “Memory Stick” of up to 32 GB, available as of January 2012. However, “Memory Stick” compatibility is not guaranteed in all cases.
- Except for personal use, it is against copyright law to use any audio and/or image data you record without prior consent from the respective copyright holder(s). Accordingly, “Memory Stick” with such copyrighted data can be used only within the law.
- Use “Memory Stick” with the “MagicGate” logo to take advantage of this technology.
- If you use “Memory Stick” in a place subject to static electricity or electrical noise, stored data may be lost.
- The maximum possible size for a file on “Memory Stick PRO Duo” or “Memory Stick PRO-HG Duo” is less than 4 GB, as defined in the file system specification.

#### Related Topic

[About “Memory Stick”](#)[Inserting/Removing “Memory Stick”](#)[Formatting “Memory Stick”](#)[Notes on Using “Memory Stick”](#)

[▶ Troubleshooting](#)**How to Use**[Parts Description](#)[Setup](#)[Network / Internet](#)[Connections](#)[Settings](#)[View](#)[Playback](#)[Backup / Recovery](#)[Security](#)[Other Operations](#)[Notifications](#)[MONITOR Function](#)

## Formatting “Memory Stick”

“Memory Stick” is formatted in the specific FAT format by default and is ready for use. Be sure to use the device that is designed to format the media and supports “Memory Stick” when formatting the media.

If you want to reformat the media with your VAIO computer, follow these steps.

**Note**

- Formatting “Memory Stick” erases the entire data stored on the media. Be sure to make a backup copy of important data to avoid erasing it.
- Do not remove “Memory Stick” from the slot while formatting. This could cause a malfunction.

1. Locate the “Memory Stick” slot.

**Hint**

- The “Memory Stick” slot on your computer also works as an SD memory card slot.

2. Carefully slide “Memory Stick” into the slot until it clicks into place. [\[Details\]](#)

3. Click (Start) and Computer.

4. Right-click the “Memory Stick” icon and select Format. The Format Memory Stick window appears.

5. Click Restore device defaults.

The size of the allocation unit and file system will change to default settings.

**Note**

- Do not select NTFS from the File system drop-down list as it may cause a malfunction.

**Hint**

- The formatting process will be completed more quickly if you select Quick Format in Format options.

6. Click Start.

Follow the on-screen instructions.

**Note**

- It may take time to format “Memory Stick” depending on the media type.

**Related Topic**[About “Memory Stick”](#)[Compatible “Memory Stick”](#)[Inserting/Removing “Memory Stick”](#)[Notes on Using “Memory Stick”](#)

[▶ Troubleshooting](#)**How to Use**[Parts Description](#)[Setup](#)[Network / Internet](#)[Connections](#)[Settings](#)[View](#)[Playback](#)[Backup / Recovery](#)[Security](#)[Other Operations](#)[Notifications](#)[MONITOR Function](#)

## Inserting/Removing SD Memory Cards

Your VAIO computer is equipped with an SD memory card slot. You can use this slot to transfer data among digital cameras, camcorders, music players, and other audio/video devices.

The SD memory card slot on the computer can accommodate the following memory cards:

- SD memory card
- SDHC memory card
- SDXC memory card

### To insert an SD memory card

1. Locate the SD memory card slot.

Hint

- The SD slot on your computer also works as a “Memory Stick” slot.
2. Hold the SD memory card with the arrow pointing toward the slot on the left side of your VAIO computer, and carefully slide it into the slot until it clicks into place.



The SD memory card icon will appear in the Computer window after you insert the card into the slot.

#### Note

- Be careful not to insert an SD memory card with wrong orientation. If you force it into the slot upside down, the slot may be damaged. Refer to the manual that came with the SD memory card for more information.
- The SD memory card icon will not appear in the Computer window until you insert the card into the slot.

Hint

- When you insert the SD memory card into the slot for the first time, you may be prompted to install driver software. If prompted, follow the on-screen instructions to install the software.
- While data is being read from or written to the SD memory card, the media access indicator light is on.

### To remove an SD memory card

1. Locate the SD memory card slot.

Hint

- The SD slot on your computer also works as a “Memory Stick” slot.
2. Check that the media access indicator light is off.
  3. Push in the SD memory card toward your VAIO computer and release.
  4. Pull the SD memory card out of the slot.

---

Related Topic

[Notes on Using SD Memory Cards](#)

---

[▶ Troubleshooting](#)**How to Use**[Parts Description](#)[Setup](#)[Network / Internet](#)[Connections](#)[Settings](#)[View](#)[Playback](#)[Backup / Recovery](#)[Security](#)[Other Operations](#)[Notifications](#)[MONITOR Function](#)

## Inserting/Removing “Memory Stick”

You can use “Memory Stick” to save data or transfer images between a digital camera and your VAIO computer. To insert/remove “Memory Stick”, follow these steps.

### To Insert “Memory Stick”

1. Locate the “Memory Stick” slot.

Hint

- The “Memory Stick” slot on your computer also works as an SD memory card slot.
2. Hold “Memory Stick” [\[Details\]](#) with the arrow pointing toward the slot on the left side of your VAIO computer, and carefully slide it into the slot until it clicks into place.



“Memory Stick” is automatically detected by your system and the contents of “Memory Stick” are displayed\*. If nothing appears on the desktop, click (Start) and Computer, and double-click the “Memory Stick” icon\*.

\* The drive letter for the “Memory Stick” slot, such as “E:”, may vary depending on the system configuration of your VAIO computer.

### Note

- The “Memory Stick” icon will appear in the Computer window after you insert “Memory Stick” into the slot.
- If “Memory Stick” cannot be inserted easily, remove it gently, and verify you are inserting it in the proper direction. Be sure to hold “Memory Stick” with the arrow pointing in the correct direction as you insert it into the slot. To avoid damaging your VAIO computer or the media, do not force “Memory Stick” into the slot if you cannot insert it smoothly.

Hint

- When you insert “Memory Stick” into the slot for the first time, you may be prompted to install driver software. If prompted, follow the on-screen instructions to install the software.

### To remove “Memory Stick”

1. Locate the “Memory Stick” slot.

Hint

- The “Memory Stick” slot on your computer also works as an SD memory card slot.
2. Check that the Media Access indicator light is off.
  3. Push in “Memory Stick” toward your VAIO computer and release.
  4. Pull “Memory Stick” out of the slot.

### Note

- Do not remove “Memory Stick” while the Media Access indicator light is on. If you do, you may lose data. Large volumes of data may take time to load, so make sure the



indicator light is off before removing “Memory Stick”.

- Be sure to remove “Memory Stick” gently, or it may pop out unexpectedly.

---

#### Related Topic

[About “Memory Stick”](#)

[Compatible “Memory Stick”](#)

[Formatting “Memory Stick”](#)

[Notes on Using “Memory Stick”](#)

---

[▶ Troubleshooting](#)**How to Use**[Parts Description](#)[Setup](#)[Network / Internet](#)[Connections](#)[Settings](#)[View](#)[Playback](#)[Backup / Recovery](#)[Security](#)[Other Operations](#)[Notifications](#)[MONITOR Function](#)

## Notes on Using SD Memory Cards

Before using SD memory cards, read the following precautions for correct use.

- Keep an SD memory card out of reach of children. There is a risk of swallowing it.
- Do not touch the SD memory card connector with your finger or metal objects.
- An SD memory card contains delicate electronic components. Do not impact, bend or drop it.
- Do not disassemble or modify an SD memory card.
- Do not wet an SD memory card.
- Do not use or store in a location subject to:
  - Extremely high temperature, such as in a car parked in the sun
  - Direct sunlight
  - High humidity or corrosive substances
  - Excessive dust
- Be sure to use SD memory cards and adaptors that are compliant with the standards supported by your VAIO computer. Incompatible cards and adaptors may get stuck in the slot, causing damage to the computer.
- You cannot write data to an SD memory card that is write-protected.
- It is recommended that you make a backup copy of important data.
- Stored data may be lost or corrupted if:
  - You remove an SD memory card or turn off your VAIO computer while the media access indicator light is on.
  - You use an SD memory card at a place where static electricity or electrical noise may disturb the card.
- When carrying an SD memory card, be sure to put it in its case to avoid static electricity.
- Before using an SD memory card with a device other than a computer, such as a digital camera or a portable audio, format (initialize) the SD memory card using the device. Some devices may not support the file format for computers and show you a message that recommends you to format the SD memory card. In this case, copy data from the card to your VAIO computer and format the card using the device. All data in the SD memory card will be deleted when you format it. Refer to the manual that came with the device for more information.
- Do not insert foreign objects into the SD memory card slot.
- The SD memory card slot can be used for reading/writing supported memory cards only, and cannot be used for other purposes.
- SD memory cards (up to 2 GB), SDHC memory cards (up to 32 GB) and SDXC memory cards (up to 64 GB) available as of January 2012 have been tested and found compatible with your VAIO computer. However, it is not guaranteed that all SD memory cards, SDHC memory cards or SDXC memory cards will be compatible with the computer.
- Do not attempt to insert a memory card or memory card adaptor of a different type into the memory card slot. An incompatible memory card or memory card adaptor may get stuck in the slot, causing damage to your VAIO computer.
- Some types of SD memory cards, for example ones with the UHS (Ultra High Speed data transfer feature), may become extremely hot due to continuous access to the memory cards. In such a case, wait for a while before removing the memory card until it cools down.

Related Topic

[Inserting/Removing SD Memory Cards](#)

---

© 2012 Sony Corporation

[▶ Troubleshooting](#)**How to Use**[Parts Description](#)[Setup](#)[Network / Internet](#)[Connections](#)[Settings](#)[View](#)[Playback](#)[Backup / Recovery](#)[Security](#)[Other Operations](#)[Notifications](#)[MONITOR Function](#)

## Notes on Using "Memory Stick"

Before using "Memory Stick", read the following precautions for correct use.

- Keep "Memory Stick" out of reach of children. There is a risk of swallowing it.
- Do not touch the "Memory Stick" connector with your finger or metal objects.



- "Memory Stick" contains delicate electronic components. Do not impact, bend or drop it.
- Do not disassemble or modify "Memory Stick".
- Do not wet "Memory Stick".
- Do not use or store in a location subject to:
  - Extremely high temperature, such as in a car parked in the sun
  - Direct sunlight
  - High humidity or corrosive substances
  - Excessive dust
- Be sure to use "Memory Stick" and adaptors that are compliant with the standards supported by your VAIO computer. Incompatible cards and adaptors may get stuck in the slot, causing damage to the computer.
- You cannot write data to "Memory Stick" that is write-protected.
- It is recommended that you make a backup copy of important data.
- Stored data may be lost or corrupted if:
  - You remove "Memory Stick" or turn off your VAIO computer while the media access indicator light is on.
  - You use "Memory Stick" at a place where static electricity or electrical noise may disturb the card.
- When carrying "Memory Stick", be sure to put it in its case to avoid static electricity.
- Before using "Memory Stick" with a device other than a computer, such as a digital camera or a portable audio, format (initialize) "Memory Stick" using the device. Some devices may not support the file format for computers and show you a message that recommends you to format "Memory Stick". In this case, copy data from "Memory Stick" to your VAIO computer and format "Memory Stick" using the device. All data in "Memory Stick" will be deleted when you format it. Refer to the manual that came with the device for more information.
- Do not insert foreign objects into the "Memory Stick" slot.
- The "Memory Stick" slot can be used for reading/writing supported "Memory Stick" only, and cannot be used for other purposes.

## Notes on Using "Memory Stick Duo"

When using "Memory Stick Duo", do not use a fine-tipped pen to write on the label adhered to "Memory Stick Duo". Exerting pressure on the media may damage internal components.

## Notes on Using "Memory Stick Micro"

Before using “Memory Stick Micro” (“M2”), be sure to insert it into an “M2” Duo adaptor. If you insert the media directly into the “Memory Stick Duo” slot without the adaptor, you may not be able to remove it from the slot.

- Keep “Memory Stick Micro” and “M2” Duo adaptors away from children. They are harmful if swallowed.

---

#### Related Topic

[About “Memory Stick”](#)

[Compatible “Memory Stick”](#)

[Inserting/Removing “Memory Stick”](#)

[Formatting “Memory Stick”](#)

---

[▶ Troubleshooting](#)

## How to Use

[Parts Description](#)[Setup](#)[Network / Internet](#)[Connections](#)[Settings](#)[View](#)[Playback](#)[Backup / Recovery](#)[Security](#)[Other Operations](#)[Notifications](#)[MONITOR Function](#)

## About the International ENERGY STAR(R) Program



The following information is applicable to ENERGY STAR qualified products only. As an ENERGY STAR Partner, Sony confirmed that this product meets the ENERGY STAR standards for energy efficiency.

The International ENERGY STAR Office Equipment Program is an international program that promotes energy saving through the use of computers and office equipment. The program backs the development and dissemination of products with functions that effectively reduce energy consumption.

For detailed information on the ENERGY STAR Program, visit the following websites:

- <http://www.energystar.gov> (USA)
- <http://www.eu-energystar.org> (Europe)

This computer is designed in compliance with the ENERGY STAR standards and delivered with the following power saving settings that apply to the computer running on AC power:

- The LCD backlight is turned off automatically after no more than 15 minutes of inactivity.
- The computer enters Sleep mode automatically after no more than 30 minutes of inactivity.

Press the  (Power) button to bring the computer back into Normal mode.

[▶ Troubleshooting](#)

## How to Use

---

[Parts Description](#)

---

[Setup](#)

---

[Network / Internet](#)

---

[Connections](#)

---

[Settings](#)

---

[View](#)

---

[Playback](#)

---

[Backup / Recovery](#)

---

[Security](#)

---

[Other Operations](#)

---

[Notifications](#)

---

[MONITOR Function](#)

---

## About the Software License

This product contains software owned by Sony and licensed by third parties. Use of such software is subject to the terms and conditions of license agreements enclosed with this product.

---

Related Topic

[Read This First](#)

---

[▶ Troubleshooting](#)

## How to Use

---

[Parts Description](#)

---

---

[Setup](#)

---

---

[Network / Internet](#)

---

---

[Connections](#)

---

---

[Settings](#)

---

---

[View](#)

---

---

[Playback](#)

---

---

[Backup / Recovery](#)

---

---

[Security](#)

---

---

[Other Operations](#)

---

---

[Notifications](#)

---

---

[MONITOR Function](#)

---

## Handling the Built-in Storage Device

The built-in storage device (hard disk drive or solid state drive) has a high storage density and reads or writes data in a short time. However, it can be easily damaged if improperly used.

If the built-in storage device is damaged, the data cannot be restored. To prevent losing data, you should be careful when handling your VAIO computer.

### To avoid damaging your built-in storage device

- Do not subject your VAIO computer to sudden movements.
- Keep your VAIO computer away from magnets.
- Do not place your VAIO computer in a location subject to mechanical vibration or in an unstable position.
- Do not turn off the power or restart your VAIO computer while reading or writing data to the storage device.
- Do not use your VAIO computer in a place subject to extreme changes in temperature.
- Do not remove the storage device from your VAIO computer.



[▶ Troubleshooting](#)

## How to Use

---

[Parts Description](#)

---

---

[Setup](#)

---

---

[Network / Internet](#)

---

---

[Connections](#)

---

---

[Settings](#)

---

---

[View](#)

---

---

[Playback](#)

---

---

[Backup / Recovery](#)

---

---

[Security](#)

---

---

[Other Operations](#)

---

---

[Notifications](#)

---

---

[MONITOR Function](#)

---

## Safety Information

Refer to the supplied safety manual for detailed safety information.

### Computer

- If you drop a solid object or any liquid onto your VAIO computer, shut down the computer and then unplug it. You may want to have the computer checked by qualified personnel before operating it again.
- Use only specified peripheral equipment and interface cables.
- Keep small parts such as “Memory Stick” and “Memory Stick” adaptors out of reach of children. There is a risk of swallowing them.

### Power source

- Do not place heavy objects on the power cord, or this could cause a fire.
- To disconnect the power cord, pull it out by holding the plug. Never pull the cord itself.
- Do not use cut or damaged connection cables.
- Unplug your VAIO computer from the AC outlet if you are not planning to use the computer for an extended period of time.
- When you replace AA batteries:
  - Be sure to use commercially available AA batteries.
  - Do not mix old (used) and new batteries.
  - Be sure to use the same type and manufacture of the battery.



### Mouse

- Do not look directly at the red light from the bottom of the optical mouse. Doing so could cause eye injuries.
- Do not look directly into the lens at the bottom of the laser mouse. Doing so could cause eye injuries. The laser light is invisible.

### Headphones

- Avoid using headphones at high volume. Hearing experts advise against continuous, loud and extended play. If you experience a ringing in your ears, reduce the volume or discontinue use.

[▶ Troubleshooting](#)**How to Use**[Parts Description](#)[Setup](#)[Network / Internet](#)[Connections](#)[Settings](#)[View](#)[Playback](#)[Backup / Recovery](#)[Security](#)[Other Operations](#)[Notifications](#)[MONITOR Function](#)**Trademarks**

- © 2012 Sony Electronics Inc. All rights reserved. Reproduction in whole or in part without written permission is prohibited.
- Sony and the Sony logo are trademarks or registered trademarks of Sony Corporation.
- VAIO, the VAIO logo and other Sony product or service names are trademarks or registered trademarks of Sony Corporation or any of its affiliates.
- i.LINK is a name to denote IEEE 1394.
- Intel, Intel Inside, Intel Core, Pentium, Intel SpeedStep, and Atom are trademarks or registered trademarks of Intel Corporation in the United States and/or other countries.
- Microsoft, Windows, Windows Vista, BitLocker, Aero, and the Windows logo are either registered trademarks or trademarks of Microsoft Corporation in the United States and/or other countries.
- Blu-ray Disc™, Blu-ray™, Blu-ray 3D™, the Blu-ray Disc logo, and the Blu-ray 3D logo are trademarks of the Blu-ray Disc Association.
- The BLUETOOTH word mark and logos are registered trademarks owned by Bluetooth SIG, Inc. and any use of such marks by Sony Corporation is under license. Other trademarks and trade names are those of their respective owners.
- Roxio Easy Media Creator is a trademark of Sonic Solutions.
- PowerDVD is trademark of CyberLink.Inc.
- NVIDIA and 3D Vision are registered trademarks and/or trademarks of NVIDIA Corporation in the United States and other countries.
- ArcSoft and the ArcSoft logo are registered trademarks of ArcSoft, Inc. ArcSoft WebCam Companion is a trademark of ArcSoft, Inc.
- AMD, the AMD Arrow logo, ATI, and combinations thereof, Radeon, AMD Phenom, AMD Turion, AMD Athlon, AMD Virtualization, AMD-V are trademarks of Advanced Micro Devices, Inc.
- SD Logo is a trademark. 
- SDHC Logo is a trademark. 
- SDXC Logo is a trademark. 
- The ExpressCard word mark and logos are owned by the PCMCIA and any use of such marks by Sony Corporation is under license. Other trademarks and trade names are those of their respective owners.
- HDMI, the HDMI logo and High-Definition Multimedia Interface are trademarks or registered trademarks of HDMI Licensing LLC.
- CompactFlash® is a trademark of SanDisk Corporation.
- “PlaceEngine” is a registered trademark of Koozyt, Inc. “PlaceEngine” was developed by Sony Computer Science Laboratories, Inc. and is licensed by Koozyt, Inc.
- “AVCHD” is a trademark of Panasonic Corporation and Sony Corporation.
- Manufactured under license from Dolby Laboratories. Dolby and the double-D symbol are trademarks of Dolby Laboratories.
- ENERGY STAR and the ENERGY STAR mark are registered U.S. marks.

All other names of systems, products, and services are trademarks of their respective owners. In the manual, the ™ or ® marks are not specified.

Features and specifications are subject to change without notice.

All other trademarks are trademarks of their respective owners.

Not all the software listed above may be delivered with your model.

---

© 2012 Sony Corporation

[▶ Troubleshooting](#)

## How to Use

---

[Parts Description](#)

---

[Setup](#)

---

[Network / Internet](#)

---

[Connections](#)

---

[Settings](#)

---

[View](#)

---

[Playback](#)

---

[Backup / Recovery](#)

---

[Security](#)

---

[Other Operations](#)

---

[Notifications](#)

---

[MONITOR Function](#)

---

## Cleaning Your VAIO computer/LCD screen

Before cleaning your VAIO computer, read the following precautions for the correct cleaning procedure.

### When cleaning your VAIO computer

- Turn off your VAIO computer and unplug the AC adapter before cleaning the computer.
- Use a soft, dry cloth to wipe debris and dust off your VAIO computer.
- Be sure to use a soft, dry cloth when cleaning your VAIO computer. If the computer is badly soiled, fog the surface of the computer with your breath and wipe off the dirt, or clean off with a lightly wet cloth and then wipe remaining moisture away with a dry cloth.
- Do not use solvents such as benzine, acetone, alcohol, thinner, or commercially available cleaners, as these may cause damage to the surface or coating of your VAIO computer.

#### Note

- Do not rub your VAIO computer when cleaning the computer, as it can be easily scratched.

### When cleaning your LCD screen

- Be sure to use a soft, dry cloth when cleaning your VAIO computer. If the LCD screen is badly soiled, fog the surface of the LCD screen with your breath and wipe off the dirt, or clean off with a lightly wet cloth and then wipe remaining moisture away with a dry cloth.
  - Do not use solvents such as benzine, acetone, alcohol, thinner, or commercially available cleaners, as these may cause damage to the LCD screen.
-

[▶ How to Use](#)**Troubleshooting**[Hardware](#)[Software](#)[Network / Internet](#)[Backup / Recovery](#)[Security](#)[Peripheral Devices](#)[Others](#)**Audio**

[What should I do if I do not hear sound from a digital audio device connected to the digital output port, such as the HDMI output port?](#)

[What should I do if I do not hear sound from speakers or headphones?](#)

[What should I do if I hear microphone feedback from speakers when using my microphone?](#)

[What should I do if my microphone does not work?](#)

[What should I do if sound interruptions occur during video or audio playback?](#)

---

[▶ How to Use](#)**Troubleshooting**[Hardware](#)[Software](#)[Network / Internet](#)[Backup / Recovery](#)[Security](#)[Peripheral Devices](#)[Others](#)**BLUETOOTH**

[What should I do if I cannot find the BLUETOOTH\(R\) device I want to communicate with?](#)

[What should I do if I cannot use the BLUETOOTH\(R\) function?](#)

[What should I do if other BLUETOOTH\(R\) devices cannot connect to my VAIO computer?](#)

[What should I do if the BLUETOOTH\(R\) icon is not displayed in the desktop notification area?](#)

[Why can't I exchange business card data with a smartphone or a mobile phone?](#)

[Why can't I use BLUETOOTH\(R\) devices when I switch users?](#)

[Why can't I use the BLUETOOTH\(R\) function when I log onto my VAIO computer as a user with a standard user account?](#)

[Why is my BLUETOOTH\(R\) connection slow?](#)

[▶ How to Use](#)**Troubleshooting**[Hardware](#)[Software](#)[Network / Internet](#)[Backup / Recovery](#)[Security](#)[Peripheral Devices](#)[Others](#)**Camera**[What should I do if captured images contain dropped frames and audio interruptions?](#)[What should I do if captured images flicker?](#)[Why are captured images poor in quality?](#)[Why does the viewfinder show no images or poor-quality images?](#)[Why is the video input from the built-in camera suspended momentarily?](#)

[▶ How to Use](#)**Troubleshooting****Hardware**

Software

Network / Internet

Backup / Recovery

Security

Peripheral Devices

Others

**Display**[How do I change the LCD brightness?](#)[What should I do if I cannot see proper images on the computer screen?](#)[What should I do if black bars appear along the top, bottom, and sides of the computer screen or an external display when I display images?](#)[What should I do if captured images contain dropped frames and audio interruptions?](#)[What should I do if captured images flicker?](#)[What should I do if my computer screen goes blank?](#)[What should I do if no image is displayed on my TV screen or external display connected to the HDMI output port?](#)[What should I do if no image is displayed on my external display or TV screen?](#)[What should I do if some items do not fit on the computer screen?](#)[What should I do if the top, bottom, and sides of images are not displayed because they are too large to fit on the computer screen or an external display?](#)[What should I do if videos are not displayed on the computer screen?](#)[What should I do if videos are not displayed smoothly?](#)[Why do sound interruptions and/or dropped frames occur when I play high-definition videos, such as those recorded with the AVCHD digital video camcorder?](#)[Why does the viewfinder show no images or poor-quality images?](#)



[▶ How to Use](#)

## Troubleshooting

## Hardware

## Software

## Network / Internet

## Backup / Recovery

## Security

## Peripheral Devices

## Others

## HDMI

[What should I do if no image is displayed on my TV screen or external display connected to the HDMI output port?](#)

You might be looking for the following topics:

[What should I do if I cannot select the input for a VCR or DVD player that is connected to the HDMI INPUT port, or I cannot switch the input source?](#)

[What should I do if there is no sound from the connected audio system?](#)

[▶ How to Use](#)**Troubleshooting**[Hardware](#)[Software](#)[Network / Internet](#)[Backup / Recovery](#)[Security](#)[Peripheral Devices](#)[Others](#)**LAN**

[How can I find the physical address \(MAC address\) of the built-in wireless network interface of my VAIO computer?](#)

[What should I do if I cannot connect my VAIO computer to an access point \(or the Internet\)?](#)

[What should I do if I cannot find \(the VAIO Smart Network icon\) in the desktop notification area?](#)

[What should I do if I cannot play back movies or audio tracks received via wireless LAN, or their playback is interrupted? Why is the data transfer speed slow?](#)

[What should I do if I cannot use the wireless LAN function?](#)

[What should I do if I do not know the SSID or security key for the access point?](#)

[What should I do if the text size on the website is small or large?](#)

[What should I do if the website is not displayed?](#)

[▶ How to Use](#)**Troubleshooting****Hardware**

Software

Network / Internet

Backup / Recovery

Security

Peripheral Devices

Others

## Microphone

[What should I do if I hear microphone feedback from speakers when using my microphone?](#)[What should I do if my microphone does not work?](#)

[▶ How to Use](#)**Troubleshooting**[Hardware](#)[Software](#)[Network / Internet](#)[Backup / Recovery](#)[Security](#)[Peripheral Devices](#)[Others](#)**Password**[What should I do if I forget the Windows password?](#)[What should I do if I forget the power-on password to start my VAIO computer?](#)[What should I do if the Enter Onetime Password message appears and Windows does not start after I enter a wrong power-on password three times consecutively?](#)

[▶ How to Use](#)

## Troubleshooting

Hardware

Software

Network / Internet

Backup / Recovery

Security

Peripheral Devices

Others

## Software

[Why do sound interruptions and/or dropped frames occur when I play high-definition videos, such as those recorded with the AVCHD digital video camcorder?](#)

You might be looking for the following topics:

[What should I do if my game software does not work or it keeps crashing?](#)

---

[▶ How to Use](#)**Troubleshooting**[Hardware](#)[Software](#)[Network / Internet](#)[Backup / Recovery](#)[Security](#)[Peripheral Devices](#)[Others](#)

## Wireless LAN

[How can I find the physical address \(MAC address\) of the built-in wireless network interface of my VAIO computer?](#)

[What should I do if I cannot connect my VAIO computer to an access point \(or the Internet\)?](#)

[What should I do if I cannot find \(the VAIO Smart Network icon\) in the desktop notification area?](#)

[What should I do if I cannot play back movies or audio tracks received via wireless LAN, or their playback is interrupted? Why is the data transfer speed slow?](#)

[What should I do if I cannot use the wireless LAN function?](#)

[What should I do if I do not know the SSID or security key for the access point?](#)

[What should I do if the text size on the website is small or large?](#)

[What should I do if the website is not displayed?](#)

[▶ How to Use](#)**Troubleshooting****Hardware**

Software

Network / Internet

Backup / Recovery

Security

Peripheral Devices

Others

**BIOS**[What should I do if I forget the power-on password to start my VAIO computer?](#)[What should I do if the VAIO logo does not appear when I turn on my VAIO computer?](#)

---

[▶ How to Use](#)**Troubleshooting**[Hardware](#)[Software](#)[Network / Internet](#)[Backup / Recovery](#)[Security](#)[Peripheral Devices](#)[Others](#)**CD/DVD/BD**[What should I do if I cannot play a disc, or dropped frames and/or sound interruptions occur during playback?](#)[What should I do if I cannot remove the disc from the optical disc drive?](#)[Why can't I write data to a disc?](#)[Why does it take time to write data to DVD-R or DVD-RW media?](#)



[▶ How to Use](#)**Troubleshooting**[Hardware](#)[Software](#)[Network / Internet](#)[Backup / Recovery](#)[Security](#)[Peripheral Devices](#)[Others](#)**Computer**[What should I do if Windows operating conditions become unstable?](#)[Why does the System Properties window display a slower CPU speed than the maximum?](#)[Why does the fan sound loud?](#)[Why is the fan audible, even when there is no operation?](#)

[▶ How to Use](#)

## Troubleshooting

Hardware

Software

Network / Internet

Backup / Recovery

Security

Peripheral Devices

Others

## Floppy disk

[What should I do if I cannot boot my VAIO computer from the floppy disk drive?](#)

You might be looking for the following topics:

[What should I do if I cannot remove my floppy disk?](#)[What should I do if I cannot save data on my floppy disk?](#)[What should I do if my VAIO computer does not recognize the floppy disk?](#)

[▶ How to Use](#)**Troubleshooting**[Hardware](#)[Software](#)[Network / Internet](#)[Backup / Recovery](#)[Security](#)[Peripheral Devices](#)[Others](#)

## Keyboard

[What should I do if I cannot enter certain characters with my keyboard?](#)[What should I do if my keyboard configuration is wrong?](#)[What should I do if the keyboard does not work?](#)

[▶ How to Use](#)**Troubleshooting**[Hardware](#)[Software](#)[Network / Internet](#)[Backup / Recovery](#)[Security](#)[Peripheral Devices](#)[Others](#)

## Memory card

[Why can't I write data to a memory card?](#)[Why doesn't the memory card icon appear in the Computer window?](#)[Why doesn't the "Memory Stick" icon appear in the Computer window?](#)

[▶ How to Use](#)**Troubleshooting**[Hardware](#)[Software](#)[Network / Internet](#)[Backup / Recovery](#)[Security](#)[Peripheral Devices](#)[Others](#)

## Mouse

[What should I do if the mouse does not work?](#)[What should I do if the mouse pointer does not move?](#)[What should I do if the mouse pointer jumps or moves slowly?](#)

[▶ How to Use](#)**Troubleshooting****Hardware**

Software

Network / Internet

Backup / Recovery

Security

Peripheral Devices

Others

**Power**[What should I do if I cannot turn off my VAIO computer?](#)[What should I do if VAIO Care Rescue starts when I turn on my VAIO computer?](#)[What should I do if my VAIO computer automatically turns on or returns to Normal mode from Sleep mode?](#)[What should I do if my VAIO computer does not enter Hibernate mode?](#)[What should I do if my VAIO computer does not enter Sleep mode?](#)[What should I do if the power indicator light turns on when I press the power button but my screen remains blank?](#)[Why does a message appear and Windows fail to start when I turn on my VAIO computer?](#)[Why does my VAIO computer automatically turn off?](#)[Why doesn't my computer screen turn off after the automatic turn-off time has passed?](#)

[▶ How to Use](#)**Troubleshooting****Hardware**

## Software

## Network / Internet

## Backup / Recovery

## Security

## Peripheral Devices

## Others

**USB**

[What should I do if I cannot boot my VAIO computer from the floppy disk drive?](#)

[What should I do if I cannot charge the device connected to the USB port that supports USB charging?](#)

You might be looking for the following topics:

[What should I do if I cannot print a document?](#)

[What should I do if I cannot remove my floppy disk?](#)

[What should I do if I cannot save data on my floppy disk?](#)

[What should I do if my VAIO computer does not recognize the USB device?](#)

[What should I do if my VAIO computer does not recognize the floppy disk?](#)

[▶ How to Use](#)

## Troubleshooting

---

[Hardware](#)[Software](#)[Network / Internet](#)

---

[Backup / Recovery](#)

---

[Security](#)

---

[Peripheral Devices](#)

---

[Others](#)

---

## Display

[Why do sound interruptions and/or dropped frames occur when I play high-definition videos, such as those recorded with the AVCHD digital video camcorder?](#)

You might be looking for the following topics:

[How do I change the LCD brightness?](#)

[What should I do if I cannot see proper images on the computer screen?](#)

[What should I do if black bars appear along the top, bottom, and sides of the computer screen or an external display when I display images?](#)

[What should I do if captured images contain dropped frames and audio interruptions?](#)

[What should I do if captured images flicker?](#)

[What should I do if my computer screen goes blank?](#)

[What should I do if no image is displayed on my TV screen or external display connected to the HDMI output port?](#)

[What should I do if no image is displayed on my external display or TV screen?](#)

[What should I do if some items do not fit on the computer screen?](#)

[What should I do if the top, bottom, and sides of images are not displayed because they are too large to fit on the computer screen or an external display?](#)

[What should I do if videos are not displayed on the computer screen?](#)

[What should I do if videos are not displayed smoothly?](#)

[Why does the viewfinder show no images or poor-quality images?](#)

---



[▶ How to Use](#)

## Troubleshooting

---

[Hardware](#)[Software](#)[Network / Internet](#)

---

[Backup / Recovery](#)

---

[Security](#)

---

[Peripheral Devices](#)

---

[Others](#)

---

## Software

[What should I do if my game software does not work or it keeps crashing?](#)[Why do sound interruptions and/or dropped frames occur when I play high-definition videos, such as those recorded with the AVCHD digital video camcorder?](#)

---

[▶ How to Use](#)**Troubleshooting**

---

[Hardware](#)

---

[Software](#)

---

[Network / Internet](#)

---

[Backup / Recovery](#)

---

[Security](#)

---

[Peripheral Devices](#)

---

[Others](#)

---

**BLUETOOTH**

[What should I do if I cannot find the BLUETOOTH\(R\) device I want to communicate with?](#)

[What should I do if I cannot use the BLUETOOTH\(R\) function?](#)

[What should I do if other BLUETOOTH\(R\) devices cannot connect to my VAIO computer?](#)

[What should I do if the BLUETOOTH\(R\) icon is not displayed in the desktop notification area?](#)

[Why can't I exchange business card data with a smartphone or a mobile phone?](#)

[Why can't I use BLUETOOTH\(R\) devices when I switch users?](#)

[Why can't I use the BLUETOOTH\(R\) function when I log onto my VAIO computer as a user with a standard user account?](#)

[Why is my BLUETOOTH\(R\) connection slow?](#)

---

[▶ How to Use](#)

## Troubleshooting

---

[Hardware](#)

---

[Software](#)[Network / Internet](#)[Backup / Recovery](#)

---

[Security](#)

---

[Peripheral Devices](#)

---

[Others](#)

---

## Wireless LAN

[How can I find the physical address \(MAC address\) of the built-in wireless network interface of my VAIO computer?](#)

[What should I do if I cannot connect my VAIO computer to an access point \(or the Internet\)?](#)

[What should I do if I cannot find \(the VAIO Smart Network icon\) in the desktop notification area?](#)

[What should I do if I cannot play back movies or audio tracks received via wireless LAN, or their playback is interrupted? Why is the data transfer speed slow?](#)

[What should I do if I cannot use the wireless LAN function?](#)

[What should I do if I do not know the SSID or security key for the access point?](#)

[What should I do if the text size on the website is small or large?](#)

[What should I do if the website is not displayed?](#)

---

[▶ How to Use](#)

## Troubleshooting

---

[Hardware](#)

---

[Software](#)[Network / Internet](#)[Backup / Recovery](#)

---

[Security](#)

---

[Peripheral Devices](#)

---

[Others](#)

---

## LAN

[How can I find the physical address \(MAC address\) of the built-in wireless network interface of my VAIO computer?](#)

[What should I do if I cannot connect my VAIO computer to an access point \(or the Internet\)?](#)

[What should I do if I cannot find \(the VAIO Smart Network icon\) in the desktop notification area?](#)

[What should I do if I cannot play back movies or audio tracks received via wireless LAN, or their playback is interrupted? Why is the data transfer speed slow?](#)

[What should I do if I cannot use the wireless LAN function?](#)

[What should I do if I do not know the SSID or security key for the access point?](#)

[What should I do if the text size on the website is small or large?](#)

[What should I do if the website is not displayed?](#)

---

[▶ How to Use](#)

## Troubleshooting

---

[Hardware](#)

---

[Software](#)

---

[Network / Internet](#)

---

[Backup / Recovery](#)

---

[Security](#)

---

[Peripheral Devices](#)

---

[Others](#)

---

## Floppy disk

[What should I do if I cannot boot my VAIO computer from the floppy disk drive?](#)

You might be looking for the following topics:

[What should I do if I cannot remove my floppy disk?](#)

[What should I do if I cannot save data on my floppy disk?](#)

[What should I do if my VAIO computer does not recognize the floppy disk?](#)

---

[▶ How to Use](#)

## Troubleshooting

---

[Hardware](#)

---

[Software](#)

---

[Network / Internet](#)

---

[Backup / Recovery](#)

---

[Security](#)

---

[Peripheral Devices](#)

---

[Others](#)

---

## USB

[What should I do if I cannot boot my VAIO computer from the floppy disk drive?](#)

You might be looking for the following topics:

[What should I do if I cannot charge the device connected to the USB port that supports USB charging?](#)

[What should I do if I cannot print a document?](#)

[What should I do if I cannot remove my floppy disk?](#)

[What should I do if I cannot save data on my floppy disk?](#)

[What should I do if my VAIO computer does not recognize the USB device?](#)

[What should I do if my VAIO computer does not recognize the floppy disk?](#)

---

[▶ How to Use](#)

## Troubleshooting

---

[Hardware](#)

---

[Software](#)

---

[Network / Internet](#)

---

[Backup / Recovery](#)

---

[Security](#)

---

[Peripheral Devices](#)

---

[Others](#)

---

## Recovery

[How can I reinstall the original software and drivers?](#)[How can I restore my VAIO computer system to its factory default settings?](#)[How do I create Recovery Media?](#)[What should I do if I cannot complete the recovery process?](#)[What should I do if I cannot create Recovery Media?](#)[What should I do if I cannot recover my VAIO computer from the recovery area?](#)[What should I do if my VAIO computer becomes unstable \(Windows does not start\)?](#)[What should I do if my VAIO computer becomes unstable \(Windows starts\)?](#)

---

[▶ How to Use](#)

## Troubleshooting

---

[Hardware](#)

---

[Software](#)

---

[Network / Internet](#)

---

[Backup / Recovery](#)

---

[Security](#)

---

[Peripheral Devices](#)

---

[Others](#)

---

## BIOS

[What should I do if I forget the power-on password to start my VAIO computer?](#)

You might be looking for the following topics:

[What should I do if the VAIO logo does not appear when I turn on my VAIO computer?](#)

---



[▶ How to Use](#)**Troubleshooting**

---

[Hardware](#)

---

[Software](#)

---

[Network / Internet](#)

---

[Backup / Recovery](#)

---

[Security](#)

---

[Peripheral Devices](#)

---

[Others](#)

---

**Password**[What should I do if I forget the Windows password?](#)[What should I do if I forget the power-on password to start my VAIO computer?](#)[What should I do if the Enter Onetime Password message appears and Windows does not start after I enter a wrong power-on password three times consecutively?](#)

---

[▶ How to Use](#)**Troubleshooting**

---

[Hardware](#)

---

[Software](#)

---

[Network / Internet](#)

---

[Backup / Recovery](#)

---

[Security](#)[Peripheral Devices](#)[Others](#)

---

## Floppy disk

[What should I do if I cannot boot my VAIO computer from the floppy disk drive?](#)[What should I do if I cannot remove my floppy disk?](#)[What should I do if I cannot save data on my floppy disk?](#)[What should I do if my VAIO computer does not recognize the floppy disk?](#)

---

[▶ How to Use](#)**Troubleshooting**

---

[Hardware](#)

---

[Software](#)

---

[Network / Internet](#)

---

[Backup / Recovery](#)

---

[Security](#)[Peripheral Devices](#)[Others](#)

---

**Peripheral device**

[What should I do if I cannot select the input for a VCR or DVD player that is connected to the HDMI INPUT port, or I cannot switch the input source?](#)

[What should I do if there is no sound from the connected audio system?](#)

---

[▶ How to Use](#)**Troubleshooting**

---

[Hardware](#)

---

[Software](#)

---

[Network / Internet](#)

---

[Backup / Recovery](#)

---

[Security](#)[Peripheral Devices](#)[Others](#)

---

**USB**[What should I do if I cannot boot my VAIO computer from the floppy disk drive?](#)[What should I do if I cannot print a document?](#)[What should I do if I cannot remove my floppy disk?](#)[What should I do if I cannot save data on my floppy disk?](#)[What should I do if my VAIO computer does not recognize the USB device?](#)[What should I do if my VAIO computer does not recognize the floppy disk?](#)

You might be looking for the following topics:

[What should I do if I cannot charge the device connected to the USB port that supports USB charging?](#)

---

[▶ How to Use](#)**Troubleshooting**

---

[Hardware](#)

---

[Software](#)

---

[Network / Internet](#)

---

[Backup / Recovery](#)

---

[Security](#)[Peripheral Devices](#)[Others](#)

---

**HDMI**

[What should I do if I cannot select the input for a VCR or DVD player that is connected to the HDMI INPUT port, or I cannot switch the input source?](#)

[What should I do if there is no sound from the connected audio system?](#)

You might be looking for the following topics:

[What should I do if no image is displayed on my TV screen or external display connected to the HDMI output port?](#)

---



[▶ How to Use](#)

**Troubleshooting**

---

Hardware

---

Software

---

Network / Internet

---

Backup / Recovery

---

Security

Peripheral Devices

Others

---

## Printer

[What should I do if I cannot print a document?](#)

---



[▶ How to Use](#)

**Troubleshooting**

---

Hardware

---

Software

---

Network / Internet

---

Backup / Recovery

---

Security

Peripheral Devices

Others

---

## i.LINK

[What should I do if I cannot use a connected i.LINK device?](#)

---



[▶ How to Use](#)

**Troubleshooting**

---

Hardware

---

Software

---

Network / Internet

---

Backup / Recovery

---

Security

---

Peripheral Devices

---

Others

**TV**

The Parental Lock password has been forgotten.

---



[▶ Troubleshooting](#)

## How to Use

---

[Parts Description](#)

---

[Setup](#)

---

[Network / Internet](#)

---

[Connections](#)

---

[Settings](#)

---

[View](#)

---

[Playback](#)

---

[Backup / Recovery](#)

---

[Security](#)

---

[Other Operations](#)

---

[Notifications](#)

---

[MONITOR Function](#)

---

## Checking the Remaining Battery Power of the Mouse

The remaining battery power of the mouse can be checked by the status light.

1. Check the status light of the mouse.



The status light flashes orange when the remaining power of the AA battery is low. The status light is only a guide and may not show the remaining battery power accurately, depending on the AA battery.

### Hint

- If you do not intend to use the mouse for a long time, set the power switch to OFF to extend battery life.

---

### Related Topic

[Parts and Controls of the Mouse](#)[Replacing the AA Battery of the Mouse](#)

---

[▶ Troubleshooting](#)**How to Use**[Parts Description](#)[Setup](#)[Network / Internet](#)[Connections](#)[Settings](#)[View](#)[Playback](#)[Backup / Recovery](#)[Security](#)[Other Operations](#)[Notifications](#)[MONITOR Function](#)

## Connecting to an Antenna (Air) for Digital Television System (ATSC Signal Standard) <TV tuner board installed models>

If your computer is equipped with a digital TV input port and you have an antenna for receiving the over-the-air signals transmitted by a digital TV broadcasting system, you can connect the antenna to the computer to receive these signals for digital televisions, for example high definition TVs.

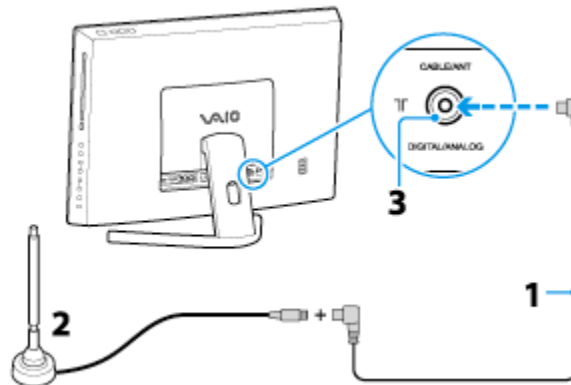

1. Connect one end of the TV coaxial cable (1) to an ATSC antenna (2).
2. Connect the other end to the CABLE/ANT (DIGITAL/ANALOG) port (3) on the computer.

### Related Topic

[Connecting to Standard Cable Access \(CATV\)<TV tuner board installed models>](#)[Connecting to a Standard Antenna<TV tuner board installed models>](#)

[▶ How to Use](#)

## Troubleshooting

---

[Hardware](#)

---

[Software](#)

---

[Network / Internet](#)

---

[Backup / Recovery](#)

---

[Security](#)

---

[Peripheral Devices](#)

---

[Others](#)

---

## What should I do if I forget the power-on password to start my VAIO computer?

- If you forget the password [\[Details\]](#), you cannot start your VAIO computer.
    - When you forget your user password:  
Enter the machine password to reset the user password at the BIOS setup screen.
    - When you forget your machine password:  
The password needs to be reset and a fee will be charged. To reset the password, contact an authorized Sony service/support center.
-

[▶ How to Use](#)**Troubleshooting**

---

[Hardware](#)

---

[Software](#)

---

[Network / Internet](#)

---

[Backup / Recovery](#)

---

[Security](#)

---

[Peripheral Devices](#)

---

[Others](#)

---

What should I do if I do not hear sound from a digital audio device connected to the digital output port, such as the HDMI output port?

- To output sound from a digital audio device connected to the digital output port on your VAIO computer, you need to change the sound output to the digital audio device.

[\[Details\]](#)

---

[▶ How to Use](#)

## Troubleshooting

---

[Hardware](#)

---

[Software](#)

---

[Network / Internet](#)

---

[Backup / Recovery](#)

---

[Security](#)

---



[Peripheral Devices](#)

---

[Others](#)

---

## What should I do if I do not hear sound from speakers or headphones?

- Check if the volume from speakers or headphones is not minimized.
  - Press the + button of the volume control buttons on the wireless keyboard to turn up the volume loud enough to hear sound.
  - Press the muting button to turn the volume on.
- Check if the volume in Windows is not turned off or minimized. [\[Details\]](#)  
When the volume is turned off () , click  (Deactivate muting) to turn on the volume (). When the volume is minimized, turn up the volume.
- When connecting external speakers or headphones, check the following:
  - Make sure external speakers or headphones are properly connected to your VAIO computer. [\[Details\]](#)
  - If external speakers require external power, make sure the speakers are securely connected to an AC outlet.
  - Make sure external speakers are turned on.
  - Make sure the volume from external speakers is not minimized.
- Make sure the sound output device is correctly selected. [\[Details\]](#)
- Check the volume on the playback software you are using.

[▶ How to Use](#)

## Troubleshooting

---

[Hardware](#)

---

[Software](#)

---

[Network / Internet](#)

---

[Backup / Recovery](#)

---

[Security](#)

---

[Peripheral Devices](#)

---

[Others](#)

---

## What should I do if I hear microphone feedback from speakers when using my microphone?

- Microphone feedback may occur when your microphone receives the sound from a sound output device, such as speakers.
    - Keep the microphone away from a sound output device.
    - Turn down the volume of the speakers and the microphone.
-

[▶ How to Use](#)

## Troubleshooting

---

[Hardware](#)

---

[Software](#)

---

[Network / Internet](#)

---

[Backup / Recovery](#)

---

[Security](#)

---

[Peripheral Devices](#)

---

[Others](#)

---

## What should I do if my microphone does not work?

- Check if your microphone is selected as a recording device.  
Click **Hardware** and **Sound** in the Control Panel window, select the **Recording** tab in the Sound window, and check if there is a check mark on your desired microphone icon. If not, select the icon and click **Set Default**. If the icon is not displayed, make sure the microphone is properly connected to your VAIO computer.
  - If you are using an external microphone, use a plug-in power microphone.
-

[▶ How to Use](#)

## Troubleshooting

---

[Hardware](#)

---

[Software](#)

---

[Network / Internet](#)

---

[Backup / Recovery](#)

---

[Security](#)

---

[Peripheral Devices](#)

---

[Others](#)

---

## What should I do if sound interruptions occur during video or audio playback?

- Sound interruptions may occur when the CPU load is high. In this case, reduce the CPU load by exiting all running software other than playback software, or by disabling unnecessary audio effects applied to playback.
-



[▶ How to Use](#)**Troubleshooting**

---

[Hardware](#)

---

[Software](#)

---

[Network / Internet](#)

---

[Backup / Recovery](#)

---

[Security](#)

---

[Peripheral Devices](#)

---

[Others](#)

---

## What should I do if I cannot find the BLUETOOTH(R) device I want to communicate with?

- Shorten the distance between your VAIO computer and the BLUETOOTH device within 33 feet/10 meters.  
If the computer is more than 33 feet/10 meters away from the BLUETOOTH device, communication will not be possible.  
The computer may not be able to communicate with the BLUETOOTH device even within 33 feet/10 meters due to obstacles between the devices, radio wave quality, ambient environment that includes existence of walls and materials of such walls, or software in use. In such a case, move the computer away from obstructions or closer to the device.
- Check that the BLUETOOTH function of the device you want to communicate with is on, and the device is not in the power saving mode.
- Check that the BLUETOOTH function of the device you want to communicate with is enabled.  
Refer to the manual that came with the device for more information.
- If the device you want to communicate with is already communicating with another BLUETOOTH device, it may not be found or it may not be able to communicate with your VAIO computer.

[▶ How to Use](#)

## Troubleshooting

---

[Hardware](#)

---

[Software](#)

---

[Network / Internet](#)

---

[Backup / Recovery](#)

---

[Security](#)

---



[Peripheral Devices](#)

---

[Others](#)

---

## What should I do if I cannot use the BLUETOOTH(R) function?

- Make sure the WIRELESS indicator light on your VAIO computer is on.
    - When the WIRELESS indicator light is off, you cannot use the BLUETOOTH function.
  - Click  (Start), All Programs, and VAIO Smart Network or click  (the VAIO Smart Network icon) in the desktop notification area to open the VAIO Smart Network settings window.  
Click the switch next to BLUETOOTH to toggle it to On.
  - Check whether the BLUETOOTH function is enabled.  
Make sure the switch next to BLUETOOTH is toggled to On.
-

[▶ How to Use](#)

## Troubleshooting

---

[Hardware](#)

---

[Software](#)

---

[Network / Internet](#)

---

[Backup / Recovery](#)

---

[Security](#)

---



[Peripheral Devices](#)

---

[Others](#)

---

## What should I do if other BLUETOOTH(R) devices cannot connect to my VAIO computer?

- See [What should I do if I cannot find the BLUETOOTH device I want to communicate with?.](#) [\[Details\]](#)
  - Make sure that the authentication (pairing) between the device and your VAIO computer has been properly performed.  
Some BLUETOOTH devices require authentication (pairing) before establishing connection with another device. Perform the authentication process before connecting to such devices.
  - Make sure that your VAIO computer allows BLUETOOTH devices to find the computer. Click  (arrow) in the desktop notification area, right-click  (the BLUETOOTH icon), and click Open Settings to open the settings window. Click the Options tab and make sure that the Allow Bluetooth devices to find this computer check box is selected.
-

[▶ How to Use](#)

## Troubleshooting

---

[Hardware](#)

---

[Software](#)

---

[Network / Internet](#)

---

[Backup / Recovery](#)

---

[Security](#)

---

[Peripheral Devices](#)

---

[Others](#)

---

## What should I do if the BLUETOOTH(R) icon is not displayed in the desktop notification area?

- Make sure that the switch next to BLUETOOTH is toggled to On in the VAIO Smart Network window.
  - Follow these steps to open the Bluetooth Settings window and check the settings: Click  (Start) and Devices and Printers. Right-click the BLUETOOTH device icon and click Bluetooth settings. Click the Options tab and select the Show the Bluetooth icon in the notification area check box.
-

[▶ How to Use](#)

## Troubleshooting

---

[Hardware](#)

---

[Software](#)

---

[Network / Internet](#)

---

[Backup / Recovery](#)

---

[Security](#)

---

[Peripheral Devices](#)

---

[Others](#)

---

## Why can't I exchange business card data with a smartphone or a mobile phone?

- Your VAIO computer does not support the data transfer function (vCard Exchange), which exchanges business card data between BLUETOOTH devices (a smartphone, a mobile phone, etc.).
-

[▶ How to Use](#)

## Troubleshooting

---

[Hardware](#)

---

[Software](#)

---

[Network / Internet](#)

---

[Backup / Recovery](#)

---

[Security](#)

---

[Peripheral Devices](#)

---

[Others](#)

---

## Why can't I use BLUETOOTH(R) devices when I switch users?

- If you switch users without logging off your system, BLUETOOTH devices will not work. Be sure to log off before switching users.
-

[▶ How to Use](#)**Troubleshooting**

---

[Hardware](#)

---

[Software](#)

---

[Network / Internet](#)

---

[Backup / Recovery](#)

---

[Security](#)

---

[Peripheral Devices](#)

---

[Others](#)

---

## Why can't I use the BLUETOOTH(R) function when I log onto my VAIO computer as a user with a standard user account?

- The BLUETOOTH function may not be available to a user with a standard user account on your VAIO computer.  
Log onto the computer as a user with administrative rights.
-

[▶ How to Use](#)

## Troubleshooting

---

[Hardware](#)

---

[Software](#)

---

[Network / Internet](#)

---

[Backup / Recovery](#)

---

[Security](#)

---

[Peripheral Devices](#)

---

[Others](#)

---

## Why is my BLUETOOTH(R) connection slow?

- Data transfer speed depends on obstructions and/or the distance between the two devices, radio wave quality, and the device configuration or software in use. Move your VAIO computer and BLUETOOTH device closer to each other.
  - If a version of a BLUETOOTH standard employed on the BLUETOOTH device with which you want to communicate is not the same version as the one employed on your VAIO computer, the communication speed may become slower.
  - If your VAIO computer is compliant with BLUETOOTH high speed technology and the following two conditions are met, high-speed communications are available. However, some BLUETOOTH profiles do not support high-speed communications.
    - The BLUETOOTH device with which you want to communicate supports BLUETOOTH high speed technology.
    - Both the wireless LAN and BLUETOOTH functions on the computer are enabled.
-



[▶ How to Use](#)

## Troubleshooting

---

[Hardware](#)

---

[Software](#)

---

[Network / Internet](#)

---

[Backup / Recovery](#)

---

[Security](#)

---

[Peripheral Devices](#)

---

[Others](#)

---

## What should I do if captured images contain dropped frames and audio interruptions?

- The effect settings on your software application may cause dropped frames. Refer to the help file included with your software application for more information.
  - There may be more software applications running than your VAIO computer can handle. Exit the applications that you are not currently using.
  - This problem may occur while your VAIO computer is running on the power saving plan, which reduces the CPU performance. Check the current power plan. [\[Details\]](#)
-

[▶ How to Use](#)

## Troubleshooting

---

[Hardware](#)

---

[Software](#)

---

[Network / Internet](#)

---

[Backup / Recovery](#)

---

[Security](#)

---

[Peripheral Devices](#)

---

[Others](#)

---

## What should I do if captured images flicker?

- This problem occurs when you use the built-in camera under fluorescent lights due to a mismatch between the lighting output frequency and the shutter speed.  
To reduce flicker noise, change the direction of your VAIO computer so that you can adjust the direction of the built-in camera. Some software applications offer adjustable parameters, such as brightness, to eliminate flicker noise.
-

[▶ How to Use](#)

## Troubleshooting

---

[Hardware](#)

---

[Software](#)

---

[Network / Internet](#)

---

[Backup / Recovery](#)

---

[Security](#)

---

[Peripheral Devices](#)

---

[Others](#)

---

## Why are captured images poor in quality?

- Images captured under fluorescent light may contain light reflections.
  - A dark portion in captured images may contain noise.
  - The area on and around the built-in camera is soiled. Clean the area. [\[Details\]](#)
-

[▶ How to Use](#)

## Troubleshooting

---

[Hardware](#)

---

[Software](#)

---

[Network / Internet](#)

---

[Backup / Recovery](#)

---

[Security](#)

---

[Peripheral Devices](#)

---

[Others](#)

---

## Why does the viewfinder show no images or poor-quality images?

- The built-in camera cannot be shared by more than one software application. Exit the current application before starting another.
  - On models with VAIO Gesture Control or Media Gallery, you cannot use another camera application that uses the built-in camera while using the gesture function of the software.
  - The viewfinder may show some noise, for example horizontal streaks, when you are viewing a rapid-moving object. This is normal and does not indicate a malfunction.
  - The built-in camera on models with a 3D-capable LCD screen is capable of capturing infrared images. Due to the characteristics of cameras that support infrared image capture, the color of images captured under incandescent light may look different from the actual color; however, this does not indicate a malfunction.
  - If the problem persists, restart your VAIO computer.
-

[▶ How to Use](#)

## Troubleshooting

---

[Hardware](#)

---

[Software](#)

---

[Network / Internet](#)

---

[Backup / Recovery](#)

---

[Security](#)

---

[Peripheral Devices](#)

---

[Others](#)

---

## Why is the video input from the built-in camera suspended momentarily?

- The video input may be suspended momentarily if:
    - A shortcut key with the Fn key is used.
    - The CPU load increases.
-

[▶ How to Use](#)

## Troubleshooting

---

[Hardware](#)

---

[Software](#)

---

[Network / Internet](#)

---

[Backup / Recovery](#)

---

[Security](#)

---

[Peripheral Devices](#)

---

[Others](#)

---

## How do I change the LCD brightness?

- Press the Fn+F5 or Fn+F6 keys to adjust the LCD brightness of your VAIO computer.  
[\[Details\]](#)
  - To adjust the LCD brightness of the connected external display, such as a computer display or a TV, use the brightness control on the external display.
-

[▶ How to Use](#)

## Troubleshooting

---

[Hardware](#)

---

[Software](#)

---

[Network / Internet](#)

---

[Backup / Recovery](#)

---

[Security](#)

---

[Peripheral Devices](#)

---

[Others](#)

---

## What should I do if I cannot see proper images on the computer screen?

- Make sure the screen color setting is set to True Color (32 bit). Refer to Windows Help and Support for more information on how to change the setting.
-

[▶ How to Use](#)

## Troubleshooting

---

[Hardware](#)

---

[Software](#)

---

[Network / Internet](#)

---

[Backup / Recovery](#)

---

[Security](#)

---

[Peripheral Devices](#)

---

[Others](#)

---

What should I do if black bars appear along the top, bottom, and sides of the computer screen or an external display when I display images?

- Change the resolution (size) of the screen image. [\[Details\]](#)
  - If you are displaying images on an external display, such as a TV, connected to your VAIO computer with an HDMI cable (not supplied), adjust the screen resolution in the HDMI output resolution settings. [\[Details\]](#)
-



[▶ How to Use](#)

## Troubleshooting

---

[Hardware](#)

---

[Software](#)

---

[Network / Internet](#)

---

[Backup / Recovery](#)

---

[Security](#)

---



[Peripheral Devices](#)

---

[Others](#)

---

## What should I do if my computer screen goes blank?

- Make sure your VAIO computer is on and not in a power saving mode. [\[Details\]](#)
- Make sure your VAIO computer is securely plugged into an AC outlet [\[Details\]](#) and the power indicator light is on.
- The display output may be set to an external display.  
Press the P key several times while holding down the Windows key to select your desired display output, and then press the Enter key. [\[Details\]](#)
- If you wait for a while and the computer screen remains blank, follow the procedures below:
  - Press and hold down the  (Power) button for more than four seconds, check if the power indicator light is off, and then turn on your VAIO computer.
  - If the problem persists, press and hold down the  (Power) button for more than four seconds and check if the power indicator light is off. Disconnect all cables and peripheral devices, such as the power cord and the USB device, and wait about five minutes. Then, put them back in place and turn on your VAIO computer again.

[▶ How to Use](#)**Troubleshooting**

---

[Hardware](#)

---

[Software](#)

---

[Network / Internet](#)

---

[Backup / Recovery](#)

---

[Security](#)

---

[Peripheral Devices](#)

---

[Others](#)

---

## What should I do if no image is displayed on my TV screen or external display connected to the HDMI output port?

- Reconnect the HDMI cable (not supplied). [\[Details\]](#)
  - Make sure you are using an HDCP-compliant display. The copyright protected content is not displayed on a non-HDCP compliant display.
  - Change the screen resolution of the connected TV or external display. [\[Details\]](#) Images may appear on the screen.
-

[▶ How to Use](#)

## Troubleshooting

---

[Hardware](#)

---

[Software](#)

---

[Network / Internet](#)

---

[Backup / Recovery](#)

---

[Security](#)

---

[Peripheral Devices](#)

---

[Others](#)

---

## What should I do if no image is displayed on my external display or TV screen?

- Press the P key several times while holding down the Windows key to select your desired display output, and then press the Enter key. [\[Details\]](#)
-

[▶ How to Use](#)

## Troubleshooting

---

[Hardware](#)

---

[Software](#)

---

[Network / Internet](#)

---

[Backup / Recovery](#)

---

[Security](#)

---

[Peripheral Devices](#)

---

[Others](#)

---

## What should I do if some items do not fit on the computer screen?

- Check that the text size is set to 100%. If not, some items, for example a software menu, may not be displayed correctly, depending on the software you are using. Refer to Windows Help and Support for more information on how to change the text size.
-

[▶ How to Use](#)

## Troubleshooting

---

[Hardware](#)

---

[Software](#)

---

[Network / Internet](#)

---

[Backup / Recovery](#)

---

[Security](#)

---

[Peripheral Devices](#)

---

[Others](#)

---

What should I do if the top, bottom, and sides of images are not displayed because they are too large to fit on the computer screen or an external display?

- Change the resolution (size) of the screen image. [\[Details\]](#)
  - If you are displaying images on an external display, such as a TV, connected to your VAIO computer with an HDMI cable (not supplied), adjust the screen resolution in the HDMI output resolution settings. [\[Details\]](#)
-

[▶ How to Use](#)

## Troubleshooting

---

[Hardware](#)

---

[Software](#)

---

[Network / Internet](#)

---

[Backup / Recovery](#)

---

[Security](#)

---

[Peripheral Devices](#)

---

[Others](#)

---

## What should I do if videos are not displayed on the computer screen?

- The video memory of your VAIO computer may be insufficient for displaying high resolution videos. In such a case, lower the resolution of the LCD screen. [\[Details\]](#)
  - If the external display is selected as the display output with the Fn+F7 keys and is disconnected from your VAIO computer, the computer screen may become unable to display a video.  
In such a case, stop video playback, press the P key several times while holding down the Windows key to select the computer screen as the display output, and then press the Enter key. Then, restart video playback.
-

[▶ How to Use](#)

## Troubleshooting

---

[Hardware](#)

---

[Software](#)

---

[Network / Internet](#)

---

[Backup / Recovery](#)

---

[Security](#)

---

[Peripheral Devices](#)

---

[Others](#)

---

## What should I do if videos are not displayed smoothly?

- It is recommended you disable your screen saver.  
If the screen saver is enabled, it may be activated during DVD playback and prevent the playback from running successfully. Some screen savers have been found to even change the display resolution and colors.
  - If you have set the display output to both the computer screen and an external display, change the display output to either of them.
  - If you have enabled Aero Themes for your desktop theme, change the current desktop theme.  
Refer to Windows Help and Support for information on how to change the theme.
  - Some videos may not be displayed smoothly depending on the type or bit rate of videos. Lowering the screen resolution may improve video playback performance. [\[Details\]](#)
  - If data access to a memory card is in progress (the media access indicator light is on), wait until the data access ends and then start playback again.
  - If you are playing a video stored on the memory card, copy it to the built-in storage device and then play the copied video.
-

[▶ How to Use](#)**Troubleshooting**

---

[Hardware](#)

---

[Software](#)

---

[Network / Internet](#)

---

[Backup / Recovery](#)

---

[Security](#)

---

[Peripheral Devices](#)

---

[Others](#)

---

Why do sound interruptions and/or dropped frames occur when I play high-definition videos, such as those recorded with the AVCHD digital video camcorder?

- Playing high-definition videos requires substantial hardware resources, such as CPU, GPU, or system memory performance on your VAIO computer. During the video playback, some operations and/or functions may become unavailable, and sound interruptions, dropped frames, and playback failure may occur depending on the configuration of the computer.
-



[▶ How to Use](#)

## Troubleshooting

---

[Hardware](#)

---

[Software](#)

---

[Network / Internet](#)

---

[Backup / Recovery](#)

---

[Security](#)

---

[Peripheral Devices](#)

---

[Others](#)

---

What should I do if I cannot select the input for a VCR or DVD player that is connected to the HDMI INPUT port, or I cannot switch the input source?

- Make sure an HDMI cable has been connected to HDMI INPUT port properly.
  - The menu of an HDMI device might be displayed. Switch the input source by pressing the INPUT button on the remote, or by pressing the INPUT/OK button on the right side of your VAIO computer.
  - Use HDMI Settings / HDMI Setup to activate the "Control for HDMI" function. This is need for your VAIO computer and the connected HDMI device.
-

[▶ How to Use](#)

## Troubleshooting

---

[Hardware](#)

---

[Software](#)

---

[Network / Internet](#)

---

[Backup / Recovery](#)

---

[Security](#)

---

[Peripheral Devices](#)

---

[Others](#)

---

## What should I do if there is no sound from the connected audio system?

- Make sure an audio system has been connected to your VAIO computer properly.
  - Use HDMI Settings / HDMI Setup to activate the “Control for HDMI” function, when you use the HDMI connection.
  - Set Speakers to Audio System in the Sound Adjustments/Sound setting.
  - Check the settings and the compatibility of the audio signal from the connected audio system.
-

[▶ How to Use](#)**Troubleshooting**

---

[Hardware](#)

---

[Software](#)

---

[Network / Internet](#)

---

[Backup / Recovery](#)

---

[Security](#)

---

[Peripheral Devices](#)

---

[Others](#)

---

## How can I find the physical address (MAC address) of the built-in wireless network interface of my VAIO computer?

- If MAC address filtering of your access point is enabled, register the MAC address of your VAIO computer in the setup screen of the access point. Otherwise, the computer cannot connect to the access point.

Click  (Start), All Programs, Accessories, Command Prompt, and then enter "ipconfig /all" and press the Enter key. You can find the physical address (MAC address) in the Physical Address field under Wireless LAN adapter Wireless Network Connection:. Enter the address in the setup screen of the access point.

---

[▶ How to Use](#)**Troubleshooting**[Hardware](#)[Software](#)[Network / Internet](#)[Backup / Recovery](#)[Security](#)[Peripheral Devices](#)[Others](#)

## What should I do if I cannot connect my VAIO computer to an access point (or the Internet)?

- See [What should I do if I cannot use the wireless LAN function?](#). [\[Details\]](#)
- Make sure power to the access point is on.
- Check the access point settings.  
In the following settings, your VAIO computer may fail to connect to an access point, or the connection may be unstable.
  - When the access point is set to refuse communication with a device whose SSID is set to "ANY," and the SSID of your VAIO computer or the access point is set to "ANY."
  - When the access point is in stealth mode.  
For more information, refer to the manual that came with your access point, or consult your wireless LAN service provider.
- Make sure your VAIO computer and access point are connected to one another. [\[Details\]](#)
- Connection capability is affected by distance, obstructions, device configuration, radio wave strength/interference, wall materials, running software, etc.  
Move your VAIO computer away from obstructions or closer to any access point you may be using.
- Check that your access point is displayed in the Currently connected to window. Click (Start), Control Panel, Network and Internet, Network and Sharing Center, and Connect to a network, and then check that your access point is displayed in the Currently connected to window.
- Make sure the security key is correct.  
The security key is displayed as "\*" for security reasons. Enter once more. [\[Details\]](#)
- Make sure your VAIO computer is properly configured for Internet access.  
If your antivirus software or firewall function of the Windows operating system imposes restrictions on Internet access, your VAIO computer may not connect to the Internet. Check the settings.
- Make sure Maximum Performance is selected for Wireless Adapter Settings in the Power Options window.  
Click (Start), Control Panel, System and Security and Power Options. Click Change plan settings for the current power plan and Change advanced power settings. Select the Advanced settings tab and double-click Wireless Adapter Settings and Power Saving Mode, and then select Maximum Performance.

[▶ How to Use](#)

## Troubleshooting

---

[Hardware](#)

---

[Software](#)

---

[Network / Internet](#)

---

[Backup / Recovery](#)

---

[Security](#)

---

[Peripheral Devices](#)

---

[Others](#)

---

What should I do if I cannot find  (the VAIO Smart Network icon) in the desktop notification area?

- Click  (arrow) in the desktop notification area to view all the icons.
-

[▶ How to Use](#)

## Troubleshooting

---

[Hardware](#)

---

[Software](#)

---

[Network / Internet](#)

---

[Backup / Recovery](#)

---

[Security](#)

---

[Peripheral Devices](#)

---

[Others](#)

---

What should I do if I cannot play back movies or audio tracks received via wireless LAN, or their playback is interrupted? Why is the data transfer speed slow?

- Move your VAIO computer away from obstructions, or closer to any access point you may be using.  
Connection capability is affected by distance, obstructions, device configuration, radio wave strength/interference, wall materials, running software, etc.
- If you are using an access point, the device may be temporarily overloaded depending on how many other devices are communicating via the access point.  
Wait for a while and try again.
- Change the channel setting of your access point. By changing the channel, interference on your wireless network may be reduced and data transfer speed may improve.  
If access point channel interference occurs, data transfer speed may be reduced.
- If your access point interferes with other access points, change the access point channel.  
Refer to the manual that came with your access point for more information.
- Make sure that a microwave oven is not operating near your wireless LAN devices.  
The 2.4 GHz frequency band, on which the wireless LAN operates, is used by various devices and apparatus. If you use a microwave oven while communicating via wireless LAN, data transfer rate may slow down, communication range may narrow, or communication may be interrupted.
- Make sure Maximum Performance is selected for Wireless Adapter Settings in the Power Options window. [\[Details\]](#)

[▶ How to Use](#)

## Troubleshooting

---

[Hardware](#)

---

[Software](#)

---

[Network / Internet](#)

---

[Backup / Recovery](#)

---

[Security](#)

---

[Peripheral Devices](#)

---

[Others](#)

---

## What should I do if I cannot use the wireless LAN function?

- Make sure that the switch next to Wireless LAN or Wi-Fi is toggled to On in the VAIO Smart Network window.
  - To use the wireless LAN function on your VAIO computer, you need to set up the function.  
Check the wireless LAN settings of the computer. [\[Details\]](#)
  - If connection utility software supplied with a third-party wireless LAN product is installed, uninstall it.  
If connection utility software is installed, Windows may fail to configure the wireless LAN settings. Be sure to take a note of your settings, (such as security keys) before uninstalling.
-

[▶ How to Use](#)

## Troubleshooting

---

[Hardware](#)

---

[Software](#)

---

[Network / Internet](#)

---

[Backup / Recovery](#)

---

[Security](#)

---

[Peripheral Devices](#)

---

[Others](#)

---

## What should I do if I do not know the SSID or security key for the access point?

- You can find the key in the setting screen of your access point.  
Refer to the manual that came with your access point for more information.
-



[▶ How to Use](#)

## Troubleshooting

---

[Hardware](#)

---

[Software](#)

---

[Network / Internet](#)

---

[Backup / Recovery](#)

---

[Security](#)

---

[Peripheral Devices](#)

---

[Others](#)

---

## What should I do if the text size on the website is small or large?

- Change the text size on your web browser.  
If you use Internet Explorer, click Page and Text Size, and then select your desired text size.
-

[▶ How to Use](#)

## Troubleshooting

---

[Hardware](#)

---

[Software](#)

---

[Network / Internet](#)

---

[Backup / Recovery](#)

---

[Security](#)

---

[Peripheral Devices](#)

---

[Others](#)

---

## What should I do if the website is not displayed?

- Depending on your Internet Service Provider (ISP), you may need to change the web browser settings.  
Refer to the manual provided from your ISP to check the web browser settings.
  - Make sure the URL in the address bar is correct.
-

[▶ How to Use](#)

## Troubleshooting

---

[Hardware](#)

---

[Software](#)

---

[Network / Internet](#)

---

[Backup / Recovery](#)

---

[Security](#)

---

[Peripheral Devices](#)

---

[Others](#)

---

## What should I do if I forget the Windows password?

- The Windows password is case-sensitive. Check your password and enter again.
  - Log on using a user account that has system administrator privileges to reset your password.
    - If you forget all passwords for system administrator accounts, you cannot reset any Windows passwords. You need to perform system recovery. [\[Details\]](#)
-

[▶ How to Use](#)

## Troubleshooting

---

[Hardware](#)

---

[Software](#)

---

[Network / Internet](#)

---

[Backup / Recovery](#)

---

[Security](#)

---

[Peripheral Devices](#)

---

[Others](#)

---

What should I do if the Enter Onetime Password message appears and Windows does not start after I enter a wrong power-on password three times consecutively?

- Press and hold down the  (Power) button for more than four seconds and check if the power indicator light is off. Then, restart your VAIO computer and enter the correct password.  
The password is case-sensitive, so be sure to check letters for the current case before you enter the password.
  - If you forget the power-on password, you cannot start your VAIO computer. [\[Details\]](#)
-

[▶ How to Use](#)

## Troubleshooting

---

[Hardware](#)

---

[Software](#)

---

[Network / Internet](#)

---

[Backup / Recovery](#)

---

[Security](#)

---

[Peripheral Devices](#)

---

[Others](#)

---

## What should I do if my game software does not work or it keeps crashing?

- Check the website of the game if there are any patches or updates to download.
  - Make sure you have installed the latest video driver software.
  - On some VAIO computer models, the graphics memory is shared with the system. The optimal graphics performance in such a case is not guaranteed.
-

[▶ How to Use](#)

## Troubleshooting

---

[Hardware](#)

---

[Software](#)

---

[Network / Internet](#)

---

[Backup / Recovery](#)

---

[Security](#)

---

[Peripheral Devices](#)

---

[Others](#)

---

## What should I do if the VAIO logo does not appear when I turn on my VAIO computer?

- The VAIO logo may not appear when you turn on your VAIO computer. In such a case, press the F2 key repeatedly within five seconds after turning on the computer.
-

[▶ How to Use](#)**Troubleshooting**

---

[Hardware](#)

---

[Software](#)

---

[Network / Internet](#)

---

[Backup / Recovery](#)

---

[Security](#)

---

[Peripheral Devices](#)

---

[Others](#)

---

## What should I do if I cannot play a disc, or dropped frames and/or sound interruptions occur during playback?

- Exit all running software other than playback software.
- Try using other playback software, such as DVD playback software.
- Change your current desktop theme to Windows 7 Basic from Control Panel if you have enabled Aero Themes for the desktop theme.
- To play DVD media with Content Protection for Recordable Media (CPRM), you need to install a CPRM pack for playback software on your VAIO computer.
- To play copyright protected Blu-ray Disc media continually, you need to update the AACS key.  
Follow a message displayed on the computer screen to update the AACS key. You can update it through the Internet.
- Uninstall playback or writing software installed on your VAIO computer after purchase.  
For instructions on how to uninstall the software, refer to the help file included with the software or Windows Help and Support.

[▶ How to Use](#)

## Troubleshooting

---

[Hardware](#)

---

[Software](#)

---

[Network / Internet](#)

---

[Backup / Recovery](#)

---

[Security](#)

---

[Peripheral Devices](#)

---

[Others](#)

---

## What should I do if I cannot remove the disc from the optical disc drive?

- The drive eject button may not work depending on your VAIO computer status. Exit all running software and press the drive eject button. If the problem persists, restart the computer and press the drive eject button again.
-



[▶ How to Use](#)

## Troubleshooting

---

[Hardware](#)

---

[Software](#)

---

[Network / Internet](#)

---

[Backup / Recovery](#)

---

[Security](#)

---

[Peripheral Devices](#)

---

[Others](#)

---

## Why can't I write data to a disc?

- DVD+R DL, DVD+R, DVD-R DL, or DVD-R media are not rewritable. You can write data to such media only once and cannot delete data on the media.
  - See Supported Discs for more information. [\[Details\]](#)
-

[▶ How to Use](#)

## Troubleshooting

---

[Hardware](#)

---

[Software](#)

---

[Network / Internet](#)

---

[Backup / Recovery](#)

---

[Security](#)

---

[Peripheral Devices](#)

---

[Others](#)

---

## Why does it take time to write data to DVD-R or DVD-RW media?

- In disc-at-once mode, it may take about 20 to 40 minutes to complete the writing process after the progress bar reaches 100%. This is normal and does not indicate a malfunction, so wait until the process is complete.

Because disc-at-once mode writes all the data to a disc at one time, the optical disc drive writes 1 GB of dummy data to a disc even when the actual data size is less than 1 GB to ensure playback compatibility.

Some players can play only discs that are created in disc-at-once mode. When you play the created disc on a player other than your VAIO computer, make sure if the player supports disc writing mode you selected.

---

[▶ How to Use](#)

## Troubleshooting

---

[Hardware](#)

---

[Software](#)

---

[Network / Internet](#)

---

[Backup / Recovery](#)

---

[Security](#)

---



[Peripheral Devices](#)

---

[Others](#)

---

## What should I do if Windows operating conditions become unstable?

- Close all running software applications, and then reboot your VAIO computer. If you cannot reboot the computer, press and hold down the  (Power) button on the computer for more than four seconds to turn it off. When the computer is turned off, the power indicator is off. If the power indicator of the computer blinks orange while rebooting (from sleep mode), release the  (Power) button then press and hold it down for more than four seconds again to turn it off. Take note that this procedure may render created or edited files unusable.
-

[▶ How to Use](#)

## Troubleshooting

---

[Hardware](#)

---

[Software](#)

---

[Network / Internet](#)

---

[Backup / Recovery](#)

---

[Security](#)

---

[Peripheral Devices](#)

---

[Others](#)

---

## Why does the System Properties window display a slower CPU speed than the maximum?

- This is normal. Because your VAIO computer's CPU utilizes a type of CPU speed controlling technology for power conservation purposes, the System Properties window may display the current CPU speed instead of the maximum speed.
-

[▶ How to Use](#)

## Troubleshooting

---

[Hardware](#)

---

[Software](#)

---

[Network / Internet](#)

---

[Backup / Recovery](#)

---

[Security](#)

---

[Peripheral Devices](#)

---

[Others](#)

---

## Why does the fan sound loud?

- The built-in fan of your VAIO computer is regulated automatically. When you use software that requires high CPU power, or when you use the computer in a high ambient temperature, the fan runs faster and may become more audible, even immediately after purchase.
-

[▶ How to Use](#)

## Troubleshooting

---

[Hardware](#)

---

[Software](#)

---

[Network / Internet](#)

---

[Backup / Recovery](#)

---

[Security](#)

---

[Peripheral Devices](#)

---

[Others](#)

---

## Why is the fan audible, even when there is no operation?

- The speed of the cooling fan of your VAIO computer is automatically adjusted according to the internal temperature.

When the CPU performs certain processing, even with no user operation, the fan may increase in speed. This is normal and does not indicate a malfunction.

---

[▶ How to Use](#)

## Troubleshooting

---

[Hardware](#)

---

[Software](#)

---

[Network / Internet](#)

---

[Backup / Recovery](#)

---

[Security](#)

---

[Peripheral Devices](#)

---

[Others](#)

---

## What should I do if I cannot boot my VAIO computer from the floppy disk drive?

- Turn on your VAIO computer and press the F11 key repeatedly until the VAIO logo disappears.  
If the computer does not boot, restart the computer and try again.
-

[▶ How to Use](#)

## Troubleshooting

---

[Hardware](#)

---

[Software](#)

---

[Network / Internet](#)

---

[Backup / Recovery](#)

---

[Security](#)

---

[Peripheral Devices](#)

---

[Others](#)

---

## What should I do if I cannot remove my floppy disk?

- Close open file(s), make sure the indicator light on the USB floppy disk drive is off, and then remove your floppy disk from the drive.
-



[▶ How to Use](#)

## Troubleshooting

---

[Hardware](#)

---

[Software](#)

---

[Network / Internet](#)

---

[Backup / Recovery](#)

---

[Security](#)

---

[Peripheral Devices](#)

---

[Others](#)

---

## What should I do if I cannot save data on my floppy disk?

- Make sure your floppy disk is properly inserted in the USB floppy disk drive connected to your VAIO computer.  
Make sure the floppy disk is right-side up before inserting it into the drive.
  - If a message indicating that your floppy disk is full appears, your floppy disk does not have enough free space.  
Change the floppy disk to another with enough free space and then save data again.
  - If a message indicating that your floppy disk is write-protected appears, slide a write-protect tab on the floppy disk to disable the write-protect feature.  
Sliding the write-protect tab to the open position enables the write-protect feature.
-

[▶ How to Use](#)

## Troubleshooting

---

[Hardware](#)

---

[Software](#)

---

[Network / Internet](#)

---

[Backup / Recovery](#)

---

[Security](#)

---

[Peripheral Devices](#)

---

[Others](#)

---

## What should I do if my VAIO computer does not recognize the floppy disk?

- Make sure the floppy disk is properly inserted in the USB floppy disk drive connected to your VAIO computer.  
Make sure the floppy disk is right-side up before inserting it into the drive.
  - Make sure the USB floppy disk drive is securely connected to your VAIO computer.
  - Remove the floppy disk from the USB floppy disk drive and then insert it again.
-

[▶ How to Use](#)

## Troubleshooting

---

[Hardware](#)

---

[Software](#)

---

[Network / Internet](#)

---

[Backup / Recovery](#)

---

[Security](#)

---

[Peripheral Devices](#)

---

[Others](#)

---

## What should I do if I cannot enter certain characters with my keyboard?

- If you cannot enter numbers by the numeric keypad, check if the Num lock icon in the desktop notification area is green or gray. (Wireless keyboard equipped model)  
When the icon is grayed out, the numeric keypad works as the directional arrow keys and the Home, Page Up, Page Down and End keys. Press the Num Lk key to change the Num lock icon to green before entering numbers. [\[Details\]](#)
- Check if the Caps Lock indicator light is on or off.  
When the indicator light is on, characters typed will appear in uppercase (or lowercase if you also hold down the Shift key).  
When the indicator light is off, characters typed will appear in lowercase (or uppercase if you also hold down the Shift key).  
Press the Shift+Caps Lock keys to turn the Caps Lock indicator light on or off.  
[\[Details\]](#)

[▶ How to Use](#)

## Troubleshooting

---

[Hardware](#)

---

[Software](#)

---

[Network / Internet](#)

---

[Backup / Recovery](#)

---

[Security](#)

---

[Peripheral Devices](#)

---

[Others](#)

---

## What should I do if my keyboard configuration is wrong?

- The language layout of your keyboard is labeled on the packaging box. If you choose a different regional keyboard when you complete the Windows setup, the key configuration will be mismatched. To change the keyboard configuration, refer to Windows Help and Support.
-

[▶ How to Use](#)

## Troubleshooting

---

[Hardware](#)

---

[Software](#)

---

[Network / Internet](#)

---

[Backup / Recovery](#)

---

[Security](#)

---

[Peripheral Devices](#)

---

[Others](#)

---

## What should I do if the keyboard does not work?

- Check the following:
    - Use the keyboard within about 33 ft. / 10 m of your VAIO computer. [\[Details\]](#)
    - Set the power switch of the keyboard to ON. [\[Details\]](#)  
The keyboard supplied with your VAIO computer has a power switch to save the AA battery power.
    - Insert new dry cell AA battery. [\[Details\]](#)
    - If the battery indicator light of the keyboard is blinking, the battery is getting low. Replace it with a new one. [\[Details\]](#)
    - Make sure the keyboard is properly connected to your VAIO computer. [\[Details\]](#)
-

[▶ How to Use](#)

## Troubleshooting

---

[Hardware](#)

---

[Software](#)

---

[Network / Internet](#)

---

[Backup / Recovery](#)

---

[Security](#)

---

[Peripheral Devices](#)

---

[Others](#)

---

## Why can't I write data to a memory card?

- Some types of memory cards are equipped with an erasure prevention switch to protect data from unintentional erasure or overwriting. Make sure the erasure prevention switch is off.
-

[▶ How to Use](#)

## Troubleshooting

---

[Hardware](#)

---

[Software](#)

---

[Network / Internet](#)

---

[Backup / Recovery](#)

---

[Security](#)

---

[Peripheral Devices](#)

---

[Others](#)

---

## Why doesn't the memory card icon appear in the Computer window?

- The icon will not appear if no memory card is inserted in the slot.
-

[▶ How to Use](#)

## Troubleshooting

---

[Hardware](#)

---

[Software](#)

---

[Network / Internet](#)

---

[Backup / Recovery](#)

---

[Security](#)

---

[Peripheral Devices](#)

---

[Others](#)

---

## Why doesn't the "Memory Stick" icon appear in the Computer window?

- The icon does not appear when no "Memory Stick" is inserted into the slot.
-



[▶ How to Use](#)

## Troubleshooting

---

[Hardware](#)

---

[Software](#)

---

[Network / Internet](#)

---

[Backup / Recovery](#)

---

[Security](#)

---

[Peripheral Devices](#)

---

[Others](#)

---

## What should I do if the mouse does not work?

- Check the following:
    - Use the mouse within 33 ft. / 10 m of your VAIO computer. [\[Details\]](#)
    - Make sure another mouse is not connected.
    - Set the power switch of the mouse to ON. [\[Details\]](#)  
The mouse supplied with your VAIO computer has a power switch to save the AA battery power.
    - Insert a new dry cell AA battery. [\[Details\]](#)
    - When the status indicator of the mouse flashes orange, the remaining battery power is low. Replace the old AA battery with a new one. [\[Details\]](#)
    - Make sure the mouse is properly connected to your VAIO computer. [\[Details\]](#)
-

[▶ How to Use](#)

## Troubleshooting

---

[Hardware](#)

---

[Software](#)

---

[Network / Internet](#)

---

[Backup / Recovery](#)

---

[Security](#)

---









[Peripheral Devices](#)

---

[Others](#)

---

## What should I do if the mouse pointer does not move?

- If the pointer does not move while a software application is running, press the Alt+F4 keys to close the application.
- If you cannot close the application using the Alt+F4 keys, press the Windows key once and then the  key several times, select Restart with the  /  key, and press the Enter key to restart your VAIO computer.
- If your VAIO computer does not restart, press the Ctrl+Alt+Delete keys, select the arrow next to the  (Shut down) button with the  /  keys and then Restart with the  /  key, and press the Enter key to restart your VAIO computer.
- If this procedure does not work, press and hold the power button until the VAIO computer turns off.  
Turning off your VAIO computer with the power button may cause loss of unsaved data.
- Avoid using any wireless devices that exchange radio signals on the 2.4 GHz band near your wireless mouse. These devices may create radio interference, causing the mouse to stop working properly.
- Do not place metal furniture or objects near your VAIO computer or wireless mouse, as this may create radio interference, causing the mouse to stop working properly.

[▶ How to Use](#)

## Troubleshooting

---

[Hardware](#)

---

[Software](#)

---

[Network / Internet](#)

---

[Backup / Recovery](#)

---

[Security](#)

---

[Peripheral Devices](#)

---

[Others](#)



---

## What should I do if the mouse pointer jumps or moves slowly?



- If the mouse pointer does not move as intended, make sure the mouse is placed on a lusterless surface (printing paper, etc.), or a mouse pad for an optical mouse, etc. The mouse pointer may not move as intended on the following surfaces:
    - Light-transmissive material (glass, etc.)
    - Light reflecting material (glossy vinyl, mirror, etc.)
    - Consistent pattern surface, such as a half tone print (photograph in magazine or newspaper, etc.)
    - Stripe or other pattern with sharp contrast
    - Gloss finish mouse pad or desk, etc.
-

[▶ How to Use](#)**Troubleshooting**[Hardware](#)[Software](#)[Network / Internet](#)[Backup / Recovery](#)[Security](#)[Peripheral Devices](#)[Others](#)

## What should I do if I cannot turn off my VAIO computer?

- Follow any of these procedures to exit all running software and then turn off your VAIO computer again.
  - Click the close button in the window of the running software.
  - Press the Alt+F4 keys.
    - If there is unsaved data, a message prompting you to save data appears. Click the button to save data.
    - Press the Alt+F4 keys until the Shut Down Windows window appears, select Shut down from the drop-down list, and click OK.
- If you have installed new software on your VAIO computer, check if the software is working properly, its data is normal, and you have operated it correctly.
- Contact the software publisher or designated provider for technical support.
- If you connect peripheral devices, such as a printer or a USB device, to your VAIO computer or connect the computer to your network, disconnect all peripheral devices or the computer's network connection and then turn off the computer.
  - While the computer is communicating with a peripheral device or the network, Windows does not allow you to turn off the computer. In addition, some peripheral device drivers for the peripheral devices do not support the feature to force the computer to shut down.
- If the computer screen freezes, press the Ctrl+Alt+Delete keys and click  (Shut down) in the lower right corner of the computer screen.
- If your VAIO computer freezes with a message indicating the settings are being saved or the computer is shutting down displayed, follow these procedures in order.
  - Press the Enter key.
    - Wait for a while.
  - If the problem persists, press the Ctrl+Alt+Delete keys.
    - Wait for a while.
- If you still cannot turn off your VAIO computer even after you follow all the above procedures in this topic, perform the following operations.
  - Note that performing these operations may cause working data to become corrupted. Be sure to disconnect the computer from the network before performing the following operations.
  - Press the Ctrl+Alt+Delete keys and click  (Shut down) in the lower right corner of the computer screen.
  - Press and hold down the  (Power) button for more than four seconds.

**Note**

  - If your VAIO computer is still on after you press and hold down the  (Power) button for more than four seconds, the PC may not be selected as an input source or the LCD screen may be off.
    - Press and release the  (Power) button to change the input source to the PC or turn on the LCD screen, then press and hold down the  (Power) button for more than four seconds.



[▶ How to Use](#)

## Troubleshooting

---

[Hardware](#)

---

[Software](#)

---

[Network / Internet](#)

---

[Backup / Recovery](#)

---

[Security](#)

---



[Peripheral Devices](#)

---

[Others](#)

---

## What should I do if VAIO Care Rescue starts when I turn on my VAIO computer?

- You may have pressed not the  (Power) button but the ASSIST button. Exit VAIO Care Rescue and check where the  (Power) button is located on your VAIO computer.
-

[▶ How to Use](#)**Troubleshooting**

---

[Hardware](#)

---

[Software](#)

---

[Network / Internet](#)

---

[Backup / Recovery](#)

---

[Security](#)

---

[Peripheral Devices](#)

---

[Others](#)

---

## What should I do if my VAIO computer automatically turns on or returns to Normal mode from Sleep mode?

- Disable the HDMI control function in HDMI Settings/HDMI Setup which automatically turns on or off your screen when you turn on or off the connected HDMI device.
-

[▶ How to Use](#)

## Troubleshooting

---

[Hardware](#)

---

[Software](#)

---

[Network / Internet](#)

---

[Backup / Recovery](#)

---

[Security](#)

---

[Peripheral Devices](#)

---

[Others](#)

---

## What should I do if my VAIO computer does not enter Hibernate mode?

- If you cannot select Hibernate mode, click Change advanced power settings and check if Allow hybrid sleep under Sleep is set to Off. If it is set to On, change it to Off. [\[Details\]](#)
-



[▶ How to Use](#)

## Troubleshooting

---

[Hardware](#)

---

[Software](#)

---

[Network / Internet](#)

---

[Backup / Recovery](#)

---

[Security](#)

---

[Peripheral Devices](#)

---

[Others](#)

---

## What should I do if my VAIO computer does not enter Sleep mode?

- If the utility program, such as a printer utility program, is running, exit the program or temporarily disable it.
  - Depending on the type of your screen saver, your VAIO computer may not enter Sleep mode while the screen saver is activated.
  - Your VAIO computer may not enter Sleep mode if you execute a task on the computer before completely entering Sleep mode.
-

[▶ How to Use](#)

## Troubleshooting

---

[Hardware](#)

---

[Software](#)

---

[Network / Internet](#)

---

[Backup / Recovery](#)

---

[Security](#)

---



[Peripheral Devices](#)

---

[Others](#)

---

## What should I do if the power indicator light turns on when I press the power button but my screen remains blank?

- Make sure the brightness and contrast controls are adjusted correctly.
- Press the Alt+F4 keys several times to close the application window. An application error may have occurred.
- If you wait for a while and the computer screen remains blank, restart your VAIO computer by following the procedures below in order. Note that following these procedures may cause working data to become corrupted.
  - Disconnect all peripheral devices, such as a printer or a USB device, and your VAIO computer from the network, if any.
  - Press and hold down the  (Power) button for more than four seconds and make sure the power indicator light is off. Then, turn on your VAIO computer again.
  - If the problem persists, press and hold down the  (Power) button for more than four seconds and make sure the power indicator light is off. Disconnect all cables connected to your VAIO computer, such as the power cord, and wait about five minutes. Then, put all cables and peripheral devices back in place and turn on the computer again.
- If an extra memory module is not installed properly, your VAIO computer may not turn on. Use of memory modules not specified by Sony or improper installation of memory modules may cause the computer to fail to boot or to become unstable. In such a case, reinstall the memory module. If you use a memory module other than the Sony branded memory module, contact the sales dealer or the manufacturer of the memory module.

[▶ How to Use](#)

## Troubleshooting

---

[Hardware](#)

---

[Software](#)

---

[Network / Internet](#)

---

[Backup / Recovery](#)

---

[Security](#)

---

[Peripheral Devices](#)

---

[Others](#)

---

## Why does a message appear and Windows fail to start when I turn on my VAIO computer?

- The BIOS boot options may have been incorrectly configured.  
Turn on your VAIO computer, press the F2 key repeatedly until the VAIO logo disappears, and check if the Boot Mode option is available in the BIOS setup screen. If available, change the option.
-

[▶ How to Use](#)

## Troubleshooting

---

[Hardware](#)

---

[Software](#)

---

[Network / Internet](#)

---

[Backup / Recovery](#)

---

[Security](#)

---

[Peripheral Devices](#)

---

[Others](#)

---

## Why does my VAIO computer automatically turn off?

- When your screen turns on by the Timer you set, the screen automatically turns off at the specified time.
-

[▶ How to Use](#)

## Troubleshooting

---

[Hardware](#)

---

[Software](#)

---

[Network / Internet](#)

---

[Backup / Recovery](#)

---

[Security](#)

---

[Peripheral Devices](#)

---

[Others](#)

---

## Why doesn't my computer screen turn off after the automatic turn-off time has passed?

- Some software applications or screen savers are designed to temporarily disable the feature of Windows that turns off the computer screen or places your VAIO computer into Sleep mode after a certain period of inactivity. To solve this problem, exit the running software application(s) or change the current screen saver.
-

[▶ How to Use](#)**Troubleshooting**

---

[Hardware](#)

---

[Software](#)

---

[Network / Internet](#)

---

[Backup / Recovery](#)

---

[Security](#)

---

[Peripheral Devices](#)

---

[Others](#)

---

What should I do if I cannot charge the device connected to the USB port that supports USB charging?

- Make sure that USB Charging Settings is enabled. [\[Details\]](#)
-

[▶ How to Use](#)

## Troubleshooting

---

[Hardware](#)

---

[Software](#)

---

[Network / Internet](#)

---

[Backup / Recovery](#)

---

[Security](#)

---

[Peripheral Devices](#)

---

[Others](#)

---

## What should I do if I cannot print a document?

- Make sure the printer settings are correctly configured.  
For information on the printer settings, refer to the manual that came with your printer.
- Make sure your printer is on.  
Refer to the manual that came with your printer for more information.
- Make sure the connections between the printer's power cord and AC adapter and between the AC adapter and an AC outlet are securely made.
- Make sure the appropriate printer driver is installed.  
When you connect a new printer, you first need to set up the printer driver. For information on how to set up the printer driver, refer to the manual that came with your printer, or visit the website of the manufacturer.
- Make sure the status of your printer is displayed as online or ready. Then, make sure the printer settings are correctly configured as instructed in the manual that came with the printer.
- Make sure your printer is set to Set as Default Printer. Refer to Windows Help and Support for more information.
- Make sure your printer is compatible with Windows installed on your VAIO computer.
- Make sure your printer is connected to your network (LAN).  
If the printer is directly connected to the network (LAN), make sure a router or a hub is on.  
If the printer is connected to a printer server, make sure an error message is not displayed on the printer server.
- Make sure your software is working properly.  
The software may not support your document format. In such a case, your document will not be printed properly. Contact the software publisher or the manufacturer of your printer.
- Make sure the correct printer port for your printer is selected.  
For more information on the printer port settings, refer to the manual that came with the printer, or contact the manufacturer.

[▶ How to Use](#)

## Troubleshooting

---

[Hardware](#)

---

[Software](#)

---

[Network / Internet](#)

---

[Backup / Recovery](#)

---

[Security](#)

---

[Peripheral Devices](#)

---

[Others](#)

---

## What should I do if my VAIO computer does not recognize the USB device?

- Check if the USB device is on and using its own power supply.
  - If you are using a digital camera, check if the battery is charged.
  - If you are using a printer, check if the power cable is connected properly to an AC outlet.
- You may need to install a USB driver for the USB device before connecting the device. Refer to the manual that came with the USB device for more information.
- Try using another USB port on your VAIO computer. The USB driver could be installed to the specific port you used the first time you connected the device.
- USB hubs may prevent the USB device from working because of a power distribution failure. We recommend you connect the device directly to your VAIO computer without a hub.
- You need to connect a USB device to the MONITOR ONLY USB port to display files, such as photos, stored on the device without starting Windows.



[▶ How to Use](#)

## Troubleshooting

---

[Hardware](#)

---

[Software](#)

---

[Network / Internet](#)

---

[Backup / Recovery](#)

---

[Security](#)

---

[Peripheral Devices](#)

---

[Others](#)

---

## How can I reinstall the original software and drivers?

- You can restore the preinstalled software and drivers using VAIO Care. To restore them, start VAIO Care [\[Details\]](#) and then click Advanced Tools, Restore and recovery, and Reinstall applications and drivers. Refer to the help file included with VAIO Care for more information.
-

[▶ How to Use](#)

## Troubleshooting

---

[Hardware](#)

---

[Software](#)

---

[Network / Internet](#)

---

[Backup / Recovery](#)

---

[Security](#)

---

[Peripheral Devices](#)

---

[Others](#)

---

## How can I restore my VAIO computer system to its factory default settings?

- There are two ways to recover your VAIO computer system: from Recovery Media [\[Details\]](#) and from the recovery area [\[Details\]](#).
-

[▶ How to Use](#)**Troubleshooting**

---

[Hardware](#)

---

[Software](#)

---

[Network / Internet](#)

---

[Backup / Recovery](#)

---

[Security](#)

---

[Peripheral Devices](#)

---

[Others](#)

---

## How do I create Recovery Media?

- You can create Recovery Media using VAIO Care. [\[Details\]](#)
-

[▶ How to Use](#)

## Troubleshooting

---

[Hardware](#)

---

[Software](#)

---

[Network / Internet](#)

---

[Backup / Recovery](#)

---

[Security](#)

---

[Peripheral Devices](#)

---

[Others](#)

---

## What should I do if I cannot complete the recovery process?

- Disconnect all unnecessary external devices from your VAIO computer.
  - Try the suggestions below:
    - Check the condition of Recovery Media. If you are using optical discs, check the discs for dirt or damage. If the discs are not clean, clean them and try recovering your VAIO computer again.
    - If you cannot recover your VAIO computer from the recovery area, restart the computer and recover the computer from the recovery area again, or use Recovery Media.
    - If you cannot recover your VAIO computer using a USB optical drive or USB flash drive, connect the drive to another USB port on the computer, then turn off the computer and try recovering it again.
  - If the problem persists, visit the VAIO online support website for further assistance.
-

[▶ How to Use](#)

## Troubleshooting

---

[Hardware](#)

---

[Software](#)

---

[Network / Internet](#)

---

[Backup / Recovery](#)

---

[Security](#)

---

[Peripheral Devices](#)

---

[Others](#)

---

## What should I do if I cannot create Recovery Media?

- Try the suggestions below:
    - Download and install the latest updates using VAIO Update.
    - Restart your VAIO computer. And then, try to create Recovery Media again.
    - If an AC adapter is supplied with an external optical disc drive, plug the AC adapter into a power source.
  - Try other reliable media.
  - If the problem persists, visit the VAIO online support website for further assistance.
-

[▶ How to Use](#)

## Troubleshooting

---

[Hardware](#)

---

[Software](#)

---

[Network / Internet](#)

---

[Backup / Recovery](#)

---

[Security](#)

---

[Peripheral Devices](#)

---

[Others](#)

---

## What should I do if I cannot recover my VAIO computer from the recovery area?

- Recover your VAIO computer from Recovery Media if you have used software to modify the recovery area, installed a different operating system from the preinstalled one, or formatted the built-in storage device without using VAIO Care Rescue.
  - If the problem persists, visit the VAIO online support website for further assistance.
-

[▶ How to Use](#)

## Troubleshooting

---

[Hardware](#)

---

[Software](#)

---

[Network / Internet](#)

---

[Backup / Recovery](#)

---

[Security](#)

---

[Peripheral Devices](#)

---

[Others](#)

---

## What should I do if my VAIO computer becomes unstable (Windows does not start)?

- Try the suggestions below:
  - Restore computer system files. [\[Details\]](#)  
Use the restore point that you created before your VAIO computer becomes unstable.
  - Restore your VAIO computer from a system image backup if you have created the backup. Refer to Windows Help and Support for more information.  
Any file you have created or changed after you created the system image backup will not be restored. You need to back up such a file with VAIO Care Rescue. [\[Details\]](#)
- Use VAIO Hardware Diagnostics to identify problems on your VAIO computer.
  - With the software, you can check if the computer hardware (a CPU, a memory module, and a built-in storage device) needs to be replaced. To start VAIO Hardware Diagnostics, click Tools and VAIO Hardware Diagnostics in VAIO Care Rescue.
- Follow the instructions in Recovering from the Recovery Area to recover your VAIO computer. [\[Details\]](#)
  - If you have not backed up your data, be sure to make a backup copy of your valuable data using VAIO Care Rescue before recovering your VAIO computer. [\[Details\]](#)  
If you have a backup created with the Windows backup feature before your VAIO computer becomes unstable, but you have created or changed the file after that, back up such a file with VAIO Care Rescue.

**Note**

- Recovering your VAIO computer will delete all the data on the built-in storage device.

[▶ How to Use](#)

## Troubleshooting

---

[Hardware](#)

---

[Software](#)

---

[Network / Internet](#)

---

[Backup / Recovery](#)

---

[Security](#)

---

[Peripheral Devices](#)

---

[Others](#)

---

## What should I do if my VAIO computer becomes unstable (Windows starts)?

- Try the suggestions below:
  - Start VAIO Care to search for a solution. [\[Details\]](#)
  - Restore computer system files. [\[Details\]](#)  
Use the restore point that you created before your VAIO computer becomes unstable.
  - Uninstall software or a software driver if your VAIO computer has become unstable after you installed the software or the software driver.
  - Reinstall the preinstalled software or software drivers on your VAIO computer if such software or software drivers have not been working properly. [\[Details\]](#)
  - Restore your VAIO computer from a system image backup if you have created the backup. Refer to Windows Help and Support for more information.
- If the problem persists, follow the instructions in Recovering from the Recovery Area to recover your VAIO computer. [\[Details\]](#)
  - If you have not yet created Recovery Media, create the Recovery Media. [\[Details\]](#)
  - Be sure to make a backup copy of your valuable data before recovering your VAIO computer. Refer to Windows Help and Support for more information.

**Note**

- Recovering your VAIO computer will delete all the data on the built-in storage device.



[▶ How to Use](#)

## Troubleshooting

---

[Hardware](#)

---

[Software](#)

---

[Network / Internet](#)

---

[Backup / Recovery](#)

---

[Security](#)

---

[Peripheral Devices](#)

---

[Others](#)

---

## What should I do if I cannot use a connected i.LINK device?

- Make sure the power of the i.LINK device is turned on, and that the i.LINK cable has been connected properly. [\[Details\]](#)
  - Turn off the i.LINK device, remove the i.LINK cable from the device, turn on the device again, and then reconnect the i.LINK cable. [\[Details\]](#)
-

[▶ How to Use](#)

## Troubleshooting

---

[Hardware](#)

---

[Software](#)

---

[Network / Internet](#)

---

[Backup / Recovery](#)

---

[Security](#)

---

[Peripheral Devices](#)

---

[Others](#)

---

The Parental Lock password has been forgotten.

- Enter 4357 for the PIN code. (PIN code 4357 is always accepted.)
-