

SONY

SONY®

4-164-314-11 (1)

AV Center

AV Center

Operating Instructions **US**

Mode d'emploi **FR**

Manual de instrucciones **ES**

Owner's Record

The model and serial numbers are located on the bottom of the unit.
Record the serial number in the space provided below.
Refer to these numbers whenever you call upon your Sony dealer regarding this product.

Model No. XAV-70BT Serial No. _____

XAV-70BT



Video CD



SensMe™



©2010 Sony Corporation

XAV-70BT
4-164-314-11 (1)

Be sure to install this unit in the dashboard of the car for safety. For installation and connections, see the supplied installation/connections manual.

Warning

To prevent fire or shock hazard, do not expose the unit to rain or moisture. To avoid electrical shock, do not open the cabinet. Refer servicing to qualified personnel only.

Lamp in this product contains mercury. Disposal of these materials may be regulated due to environmental considerations. For disposal or recycling information, please contact your local authorities or the Electronic Industries Alliance (www.eiae.org).

CAUTION

The use of optical instruments with this product will increase eye hazard. As the laser beam used in this CD/DVD player is harmful to eyes, do not attempt to disassemble the cabinet. Refer servicing to qualified personnel only.

FOR UNITED STATES CUSTOMERS. NOT APPLICABLE IN CANADA, INCLUDING IN THE PROVINCE OF QUEBEC.

POUR LES CONSOMMATEURS AUX ÉTATS-UNIS. NON APPLICABLE AU CANADA, Y COMPRIS LA PROVINCE DE QUÉBEC.

This equipment has been tested and found to comply with the limits for a Class B digital device, pursuant to Part 15 of the FCC Rules. These limits are designed to provide reasonable protection against harmful interference in a residential installation. This equipment generates, uses, and can radiate radio frequency energy and, if not installed and used in accordance with the instructions, may cause harmful interference to radio communications. However, there is no guarantee that interference will not occur in a particular installation. If this equipment does cause harmful interference to radio or television reception, which can be determined by turning the equipment off and on, the user is encouraged to try to correct the interference by one or more of the following measures:

- Reorient or relocate the receiving antenna.
- Increase the separation between the equipment and receiver.
- Connect the equipment into an outlet on a circuit different from that to which the receiver is connected.
- Consult the dealer or an experienced radio/TV technician for help.

You are cautioned that any changes or modifications not expressly approved in this manual could void your authority to operate this equipment.

This device complies with Part 15 of the FCC Rules and RSS-Gen of IC Rules. Operation is subject to the following two conditions: (1) this device may not cause harmful interference, and (2) this device must accept any interference received, including interference that may cause undesired operation.

This transmitter must not be co-located or operated in conjunction with any other antenna or transmitter.

This equipment complies with FCC and IC radiation exposure limits set forth for uncontrolled equipment and meets the FCC radio frequency (RF) Exposure Guidelines in Supplement C to OET65 and RSS-102 of the IC radio frequency (RF) Exposure rules. This equipment has very low levels of RF energy that it deemed to comply without maximum permissive exposure evaluation (MPE). But it is desirable that it should be installed and operated with at least 20 cm and more between the radiator and person's body (excluding extremities: hands, wrists, feet and ankles).

For the State of California, USA only

Perchlorate Material – special handling may apply, See www.dtsc.ca.gov/hazardouswaste/perchlorate
 Perchlorate Material: Lithium battery contains perchlorate

Warning if your car's ignition has no ACC position

Be sure to set the Auto Off function (page 52).
 The unit will shut off completely and automatically in the set time after the unit is turned off, which prevents battery drain.
 If you do not set the Auto Off function, press and hold (SOURCE/OFF) until the display disappears each time you turn the ignition off.

To cancel the demonstration (Demo) display, see page 55.



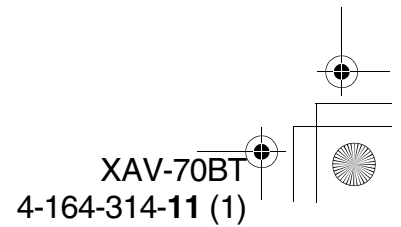
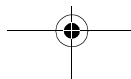
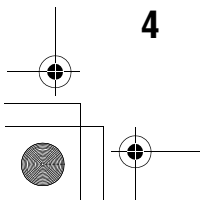
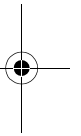
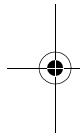
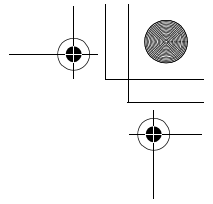
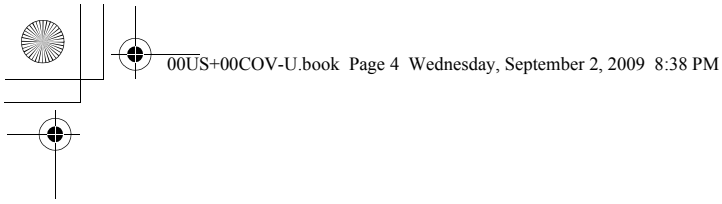

Table of Contents

Notes on safety	8
Notes on installation	8
Copyrights	8
Notes on Bluetooth	10
Playable discs and symbols used in this manual	11
Location and function of controls	12
Main unit	12
Card remote commander RM-X170	14

Getting Started

Resetting the unit	16
Performing initial settings	16
Preparing the card remote commander	16

Basic Operations

Listening to the radio	17
Playing discs	19

Advanced Operations — Radio

Storing and receiving stations	23
Storing automatically — BTM	23
Storing manually	23
Receiving stored stations	23
RDS	23
Overview	23
Selecting PTY	24
Setting CT	24

Advanced Operations — Discs

Using PBC functions — Playback control ...	24
Configuring audio settings	25
Changing the audio language/format	25
Changing the audio channel	25
Adjusting the audio output level	
— Dolby D level	25
Locking discs — Parental control	26
Activating parental control	26
Changing the area and its movie rating level	26
Repeat and shuffle play	26
Direct search play	27

USB Device Operations

Playing a USB device	28
Repeat and shuffle play	28
Enjoying music according to your mood	
— SensMe™	29
Before using the SensMe™ function	29
Installing “SensMe™ Setup” and “Content Transfer” in your computer	29
Registering a USB device using “SensMe™ Setup”	30
Transferring tracks to the USB device using “Content Transfer”	30
Playing tracks in the channel	
— SensMe™ channels	30
Playing tracks in the mood map	
— SensMe™ mood	31

iPod Operations

Playing an iPod	32
Setting the play mode	33
Repeat and shuffle play	33
Operating an iPod directly	
— Passenger control	34

continue to next page →

Useful Functions

Listing up tracks/images/video files	
— List	34
Selecting a track/image/video file	34
Selecting a file type	34
Searching a track by listening to track passages	
— ZAPPIN™	35
Using Gesture Command	35

Handsfree Calling and Audio Streaming — Bluetooth

Before using the Bluetooth function	36
Basic procedure of the Bluetooth function	36
Bluetooth status indication	36
Installing the external microphone XA-MC10	37
Paring	37
Searching from this unit	37
Searching from the Bluetooth device	37
Connecting	38
Handsfree calling	39
Making calls	39
Receiving calls	40
Operations during a call	40
Phonebook management	41
Storing phonebook data	41
Browsing a phonebook in a cellular phone	42
Deleting phonebook data	42
Editing a contact	43
Call data management	43
Call history	43
Preset dial	44
Locking the personal information	44
Audio streaming	44
Listening to a Bluetooth device through this unit	44
Operating the Bluetooth device with this unit	45
Bluetooth settings	45

Sound Adjustment

Selecting the sound quality — EQ7	46
Customizing the equalizer curve	
— EQ7 Tune	46
Adjusting the sound characteristics	46
Optimizing sound for the listening position	
— Intelligent Time Alignment	47
Precisely calibrating the listening position	
— Intelligent Time Alignment Tune	47
Speaker configuration and volume setup	48
Creating a virtual center speaker	
— CSO	48
Using rear speakers as subwoofer	
— RBE	48
Adjusting the speaker volume	48

Monitor Adjustment

Adjusting the monitor angle	49
Touch panel calibration	49
Setting the background screen	49
Selecting the picture quality	
— Picture EQ	49
Customizing the picture quality	50
Selecting the aspect ratio	50

Settings

Basic setting operation	51
General settings	52
Sound settings	54
Screen settings	55
DVD and other playback settings	56
Setting the security code	59
Setting the clock	59

Using Optional Equipment

Auxiliary audio/video equipment	59
Rear view camera	60
Displaying the picture	60
Rear view camera settings	60

Additional Information

Precautions 61

 Notes on LCD panel 61

 Notes on discs 61

 Playback order of MP3/WMA/AAC/JPEG/
 MPEG-4 files 62

 About MP3 files 62

 About WMA files 62

 About AAC files 62

 About JPEG files 62

 About MPEG-4 files 63

 About iPod 63

 About Bluetooth function 63

Maintenance 64

Removing the unit 64

Specifications 65

Troubleshooting 66

 Error displays/messages 70

Language code/area code list 71

Index 72



Support site

If you have any questions or for the latest support information on this product, please visit the web site below:

<http://esupport.sony.com>
<http://www.xplodsony.com/>

Provides information on:

- Models and manufacturers of compatible digital audio players
- Models and manufacturers of compatible cellular phones and the FAQ about Bluetooth function

Notes on safety

- Comply with your local traffic rules, laws and regulations.
- While driving
 - Do not watch or operate the unit, as it may lead to distraction and cause an accident. Park your car in a safe place to watch or operate the unit.
 - Do not use the setup feature or any other function which could divert your attention from the road.
 - **When backing up your car, be sure to look back and watch the surroundings carefully for your safety, even if the rear view camera is connected. Do not depend on the rear view camera exclusively.**
- While operating
 - Do not insert your hands, fingers or foreign object into the unit while functioning, as it may cause injury or damage to the unit.
 - Keep small articles out of the reach of children.
 - Be sure to fasten seatbelts to avoid injury in the event of a sudden movement of the car.

Preventing an accident

Pictures appear only after you park the car and set the parking brake.

If the car starts moving during video playback, the picture is automatically switched to the background screen after displaying the caution below.

“Video blocked for your safety.”

The monitor connected to the REAR VIDEO OUT is active while the car is in motion.

The picture on the display is switched to the background screen, but audio source can be heard.

Do not operate the unit or watch the monitor while driving.

Notes on installation

- We recommend this unit should be installed by a qualified technician or service personnel.
 - If you try to install this unit by yourself, see the supplied installation/connections manual and install the unit properly.
 - Improper installation may cause battery drain or a short circuit.
- If the unit does not work properly, check the connections first, referring to the supplied installation/connections manual. If everything is in order, check the fuse.
- Protect the unit surface from damage.
 - Do not expose the unit surface to chemicals, such as insecticide, hair spray, insect repellent, etc.
 - Do not leave rubber or plastic materials in contact with the unit for a long time. Otherwise, the finish of the unit may be impaired, or deformation may occur.
- When installing, be sure to fix securely.
- When installing, be sure to turn the ignition off. Installing the unit with the ignition on may cause battery drain or a short circuit.
- When installing, be sure not to damage any car parts such as pipes, tubes, fuel tank or wiring by using a drill, as it may cause a fire or an accident.

Copyrights

This product incorporates copyright protection technology that is protected by U.S. patents and other intellectual property rights. Use of this copyright protection technology must be authorized by Macrovision, and is intended for home and other limited viewing uses only unless otherwise authorized by Macrovision. Reverse engineering or disassembly is prohibited.

 Manufactured under license from Dolby Laboratories. “Dolby” and the double-D symbol are trademarks of Dolby Laboratories.



Windows Media and the Windows logo are trademarks or registered trademarks of Microsoft Corporation in the United States and/or other countries.

“DVD VIDEO,” “DVD-R,” “DVD-RW,” “DVD+R,” and “DVD+RW” are trademarks.

The *Bluetooth* word mark and logos are owned by the Bluetooth SIG, Inc. and any use of such marks by Sony Corporation is under license. Other trademarks and trade names are those of their respective owners.

ZAPPIN is a trademark of Sony Corporation.



12 TONE ANALYSIS and its logo are trademarks of Sony Corporation.



“WALKMAN” and “WALKMAN” logo are registered trademarks of Sony Corporation.



SensMe and the SensMe logo are trademarks or registered trademarks of Sony Ericsson Mobile Communications AB.



Music recognition technology and related data are provided by Gracenote®. Gracenote is the industry standard in music recognition technology and related content delivery. For more information, please visit www.gracenote.com.

CD and music-related data from Gracenote, Inc., copyright © 2000-2009 Gracenote. Gracenote Software, copyright © 2000-2009 Gracenote. This product and service may practice one or more of the following U.S. Patents: #5,987,525; #6,061,680; #6,154,773; #6,161,132; #6,230,192; #6,230,207; #6,240,459; #6,330,593, and other patents issued or pending. Some services supplied under license from Open Globe, Inc. for U.S. Patent: #6,304,523.

Gracenote and CDDB are registered trademarks of Gracenote. The Gracenote logo and logotype, and the “Powered by Gracenote” logo are trademarks of Gracenote.

This product uses font data which is licensed to Sony by Monotype Imaging Inc. or its affiliates.

iPod is a trademark of Apple Inc., registered in the U.S. and other countries.

iPhone is a trademark of Apple Inc.

THIS PRODUCT IS LICENSED UNDER THE MPEG-4 VISUAL PATENT PORTFOLIO LICENSE FOR THE PERSONAL AND NON-COMMERCIAL USE OF A CONSUMER FOR DECODING MPEG-4 VIDEO THAT WAS ENCODED BY A CONSUMER ENGAGED IN A PERSONAL AND NON-COMMERCIAL ACTIVITY AND/OR WAS OBTAINED FROM A VIDEO PROVIDER LICENSED BY MPEG LA TO PROVIDE MPEG-4 VIDEO. NO LICENSE IS GRANTED OR SHALL BE IMPLIED FOR ANY OTHER USE. ADDITIONAL INFORMATION INCLUDING THAT RELATING TO PROMOTIONAL, INTERNAL AND COMMERCIAL USES AND LICENSING MAY BE OBTAINED FROM MPEG LA, LLC. SEE [HTTP://WWW.MPEGLA.COM](http://WWW.MPEGLA.COM)



The “HD Radio Ready” logo indicates that this product will control a Sony HD Radio™ tuner (sold separately).

For HD Radio™ tuner operation, please refer to the HD Radio™ tuner Operating Instructions.

HD Radio™ and the HD Radio Ready logo are proprietary trademarks of iBiquity Digital Corp.



The “SAT Radio Ready” logo indicates that this product will control a satellite radio tuner module (sold separately). Please see your nearest authorized Sony dealer for details on the satellite radio tuner module.

“SAT Radio,” “SAT Radio Ready,” the SAT Radio and SAT Radio Ready logos and all related marks are trademarks of Sirius XM Radio Inc. and XM Satellite Radio Inc.

Notes on Bluetooth

Caution

IN NO EVENT SHALL SONY BE LIABLE FOR ANY INCIDENTAL, INDIRECT OR CONSEQUENTIAL DAMAGES OR OTHER DAMAGES INCLUDING, WITHOUT LIMITATION, LOSS OF PROFITS, LOSS OF REVENUE, LOSS OF DATA, LOSS OF USE OF THE PRODUCT OR ANY ASSOCIATED EQUIPMENT, DOWNTIME, AND PURCHASER'S TIME RELATED TO OR ARISING OUT OF THE USE OF THIS PRODUCT, ITS HARDWARE AND/OR ITS SOFTWARE.

IMPORTANT NOTICE!

Safe and efficient use

Changes or modifications to this unit not expressly approved by Sony may void the user's authority to operate the equipment.

Please check for exceptions, due to national requirement or limitations, in usage of Bluetooth equipment before using this product.

Driving

Check the laws and regulations on the use of cellular phones and handsfree equipment in the areas where you drive.

Always give full attention to driving and pull off the road and park before making or answering a call if driving conditions so require.

Connecting to other devices

When connecting to any other device, please read its user guide for detailed safety instructions.

Radio frequency exposure

RF signals may affect improperly installed or inadequately shielded electronic systems in cars, such as electronic fuel injection systems, electronic antiskid (antilock) braking systems, electronic speed control systems or air bag systems. For installation or service of this device, please consult with the manufacturer or its representative of your car. Faulty installation or service may be dangerous and may invalidate any warranty that may apply to this device.

Consult with the manufacturer of your car to ensure that the use of your cellular phone in the car will not affect its electronic system.

Check regularly that all wireless device equipment in your car is mounted and operating properly.

Emergency calls

This Bluetooth car handsfree and the electronic device connected to the handsfree operate using radio signals, cellular, and landline networks as well as user-programmed function, which cannot guarantee connection under all conditions.

Therefore do not rely solely upon any electronic device for essential communications (such as medical emergencies).

Remember, in order to make or receive calls, the handsfree and the electronic device connected to the handsfree must be switched on in a service area with adequate cellular signal strength.



Emergency calls may not be possible on all cellular phone networks or when certain network services and/or phone features are in use.

Check with your local service provider.

Playable discs and symbols used in this manual

This unit can play various video/audio discs.

The following chart helps you to check if a disc is supported by this unit, as well as what functions are available for a given disc type.

	Disc symbol in manual	Disc format
VIDEO		DVD VIDEO
		DVD-R*¹ / DVD-R DL*¹ / DVD-RW*¹ (Video mode/VR mode)
		DVD+R*¹ / DVD+R DL*¹ / DVD+RW*¹
		Video CD (Ver. 1.0/1.1/2.0)
AUDIO		Audio CD
		CD-ROM*² / CD-R*² / CD-RW*²

*¹ Audio files can also be stored.





*² Video/image files can also be stored.

Note

"DVD" may be used in this manual as a general term for DVD VIDEOS, DVD-Rs/DVD-RWs, and DVD+Rs/DVD+RWs.

The following chart shows the supported compression formats and their file types.

Available functions differ depending on the format, regardless of disc type. The format symbols below appear next to the description of functions available for that format.

Format symbol in manual	File type
	MP3 audio file
	WMA audio file
	AAC audio file
	JPEG image file
	MPEG-4 video file

Tip

For details on compression formats, see page 62.

Note

Even compatible discs may not be playable on this unit, depending on their recorded condition.

Location and function of controls

Main unit

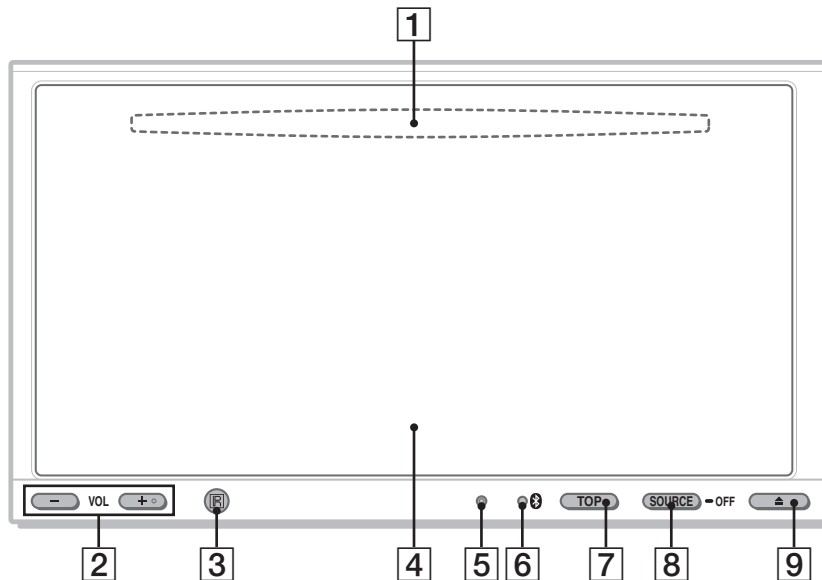

Refer to the pages listed for details.

- 1** **Disc slot** (located behind the front panel)
page 19
- 2** **VOL (Volume) -/+*1 buttons**
- 3** **Receptor for the card remote commander**
- 4** **Display window/touch panel**
- 5** **Reset button** page 16
- 6** **Bluetooth signal indicator**
page 36

7 **TOP button**

To open the top menu.

8 **SOURCE/OFF button*2**

Press to turn on the power/change the source: "Tuner" (Radio), "Disc," "AUX" (Auxiliary equipment), "USB/iPod," "BT Audio" (Bluetooth Audio).

Press for 1 second to turn off the power. Press for more than 2 seconds to shut off completely.

9 **▲ (Open/Close) button** page 19

*1 The VOL + button has a tactile dot.

*2 If an HD Radio tuner or SAT tuner is connected: when (SOURCE/OFF) is pressed, the connected device ("HD Radio," "XM" or "Sirius") will appear in the display.

Screen displays

When no source is selected:

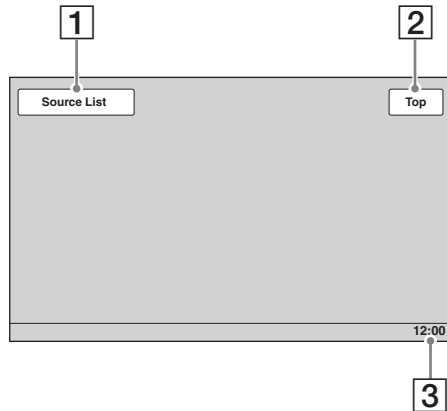

Top menu:

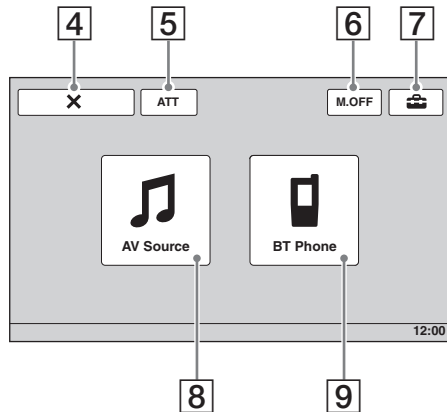

Source list:

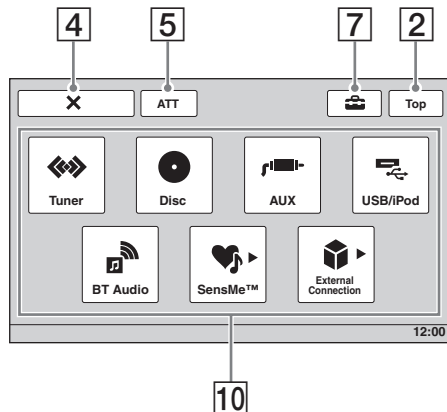

- 1 **“Source List” key**
To open the source list.
- 2 **“Top” key**
To open the top menu.
- 3 **Clock display** page 55, 59
- 4 **X (Close) key**
To close the menu.
- 5 **“ATT” (Attenuate) key**
To attenuate the sound. To cancel, touch again.
- 6 **“M.OFF” (Monitor off) key**
To turn off the monitor and the button illumination. To turn back on, touch anywhere on the display.
- 7 **⚙️ (Setting) key**
To open the setting menu.
- 8 **“AV Source” key**
To open the source list.
- 9 **“BT Phone” key**
To enter the Bluetooth Phone mode.
- 10 **Source select keys***
To change the source: “Tuner” (Radio), “Disc,” “AUX” (Auxiliary equipment), “USB/iPod,” “BT Audio” (Bluetooth Audio), “SensMe™.”

* If an HD Radio tuner or SAT tuner is connected: to select the connected device, touch “External Connection,” then “HD Radio,” “XM” or “Sirius.”

Card remote commander RM-X170

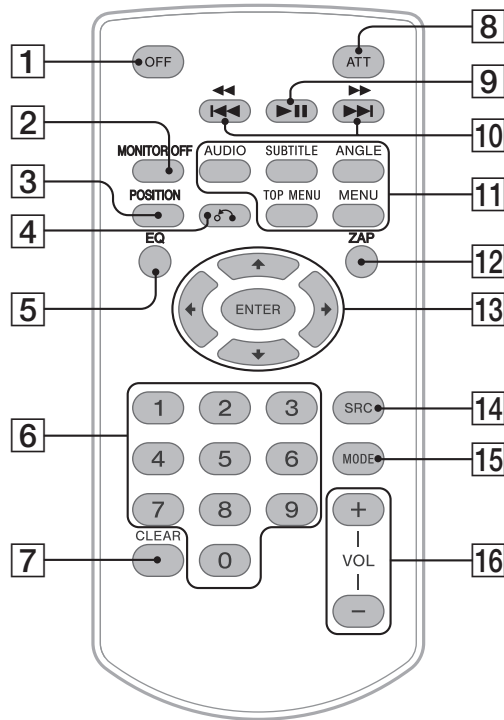

- The card remote commander can be generally used to operate the audio controls simply. For menu operations, use the touch panel.
- Refer to the pages listed for details.
- Remove the insulation film before use (page 16).

1 OFF button

Press to turn off/stop the source.
Press and hold to shut off completely.

2 MONITOR OFF button

To turn off the monitor and the button illumination. To turn back on, press again.

3 POSITION button

To switch the listening position ("Front L"/"Front R"/"Front"/"All"/"Custom").

4 ↶ (Return) button

To return to the previous display/return to the menu on a VCD*1.

5 EQ (Equalizer) button

To select an equalizer curve from 7 music types ("Xplod"/"Vocal"/"Edge"/"Cruise"/"Space"/"Gravity"/"Custom").

6 Number buttons page 27

Radio:

Press to receive stored stations.
Press and hold to store stations.

Disc/USB:

To locate a title/chapter/track.

7 CLEAR button

To delete an entered number.

8 ATT (Attenuate) button

To attenuate the sound. To cancel, press again.

9 ►|| (Play/Pause) button

10  **buttons****Radio:**

Press to tune in stations automatically.
Press and hold to find a station manually.

Disc*2/USB:

Press to skip a chapter/track/scene/file.
Press and hold momentarily to reverse/fast-forward the video.
Press and hold to reverse/fast-forward track.

Bluetooth Audio*3:

Press to skip a track.
Press and hold to reverse/fast-forward track.

*1 When playing with PBC function.

*2 Operation differs depending on the disc (page 21).

*3 Operation differs depending on the connected Bluetooth device.

*4 If an HD Radio tuner or SAT tuner is connected: when **(SRC)** is pressed, the connected device ("HD Radio," "XM" or "Sirius") will appear in the display. Furthermore, if **(MODE)** is pressed, you can switch the HD Radio tuner band or SAT tuner band.

*5 When two external devices are used.

Note

If the unit is turned off and the display disappears, it cannot be operated with the card remote commander unless **(SOURCE/OFF)** on the main unit is pressed, or a disc is inserted to activate the unit first.

11 **DVD playback setting buttons****(AUDIO)**:

To change the audio language/format.
(For VCD/CD/MP3/WMA/AAC/MPEG-4, to change the audio channel.)

(SUBTITLE):

To change the subtitle language.

(ANGLE):

To change the viewing angle.

(TOP MENU):

To open the top menu on a DVD.

(MENU):

To open the menu on a disc.

12 **ZAP button**

To enter the ZAPPIN™ mode.

13  **(Cursor)/ENTER buttons**

page 19

To control the menu on a DVD.

14 **SRC (Source) button*4**

To turn on/change the source: "Tuner" (Radio), "Disc," "AUX" (Auxiliary equipment), "USB/iPod," "BT Audio" (Bluetooth Audio).

15 **MODE button*4**

Press to select the radio band (FM/AM)/select an external device*5.

16 **VOL (Volume) +/- buttons**

Getting Started

Resetting the unit

Before operating the unit for the first time, or after replacing the car battery or changing the connections, you must reset the unit. Press the reset button (page 12) with a pointed object, such as a ball-point pen.

Note

Pressing the reset button will erase the clock setting and some stored contents.

Preparing the card remote commander

Before using the card remote commander for the first time, remove the insulation film.



Performing initial settings

After resetting, the display for the initial settings appears.

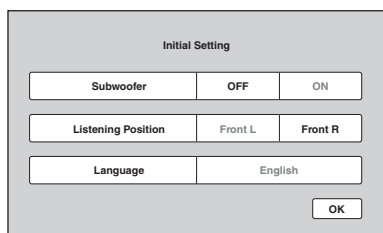

- 1 Set the subwoofer connection status.**
Touch "ON" of "Subwoofer" if a subwoofer is connected, or "OFF" if not.
- 2 Set the listening position.**
Touch "Front L" of "Listening Position" if your listening position is front left, or "Front R" if front right.
- 3 Set the display language.**
Touch the setting of "Language" repeatedly until the desired language (English/Russian/Spanish) appears.
- 4 Touch "OK."**
The setting is complete.

This setting can then be further configured in the setting menu.

- For details on setting the subwoofer connection status, see page 54.
- For details on setting the listening position, see "Optimizing sound for the listening position — Intelligent Time Alignment" on page 47.
- For details on setting the display language, see page 52.

Basic Operations

Listening to the radio

1 Touch "Source List," then "Tuner."

From the top menu, touch "AV Source," then "Tuner."
The radio reception display appears.

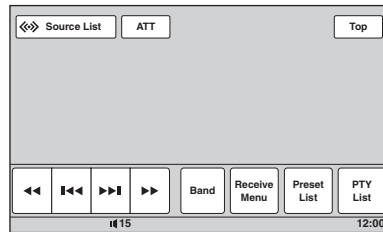

2 Touch "Band."

The band list appears.

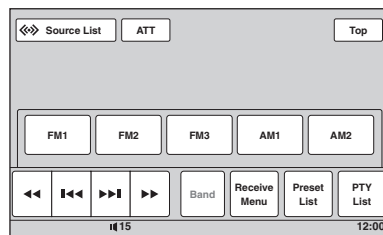

3 Touch the desired band ("FM1," "FM2," "FM3," "AM1" or "AM2").

Touch "Band" to close the band list.

4 Perform tuning.

To tune automatically

Touch **◀◀▶▶**.

Scanning stops when the unit receives a station. Repeat this procedure until the desired station is received.

To tune manually

Touch **◀▶** repeatedly until the desired frequency is received.

To skip frequencies continuously, touch and hold **◀◀▶▶**.

continue to next page →

Reception controls

Touch the display if the reception controls are not shown.

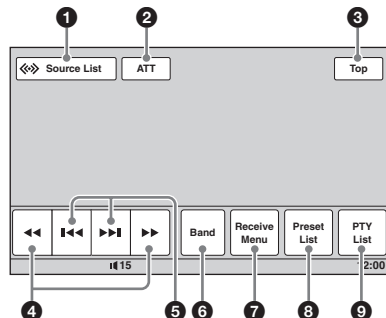

No.	Item	Touch to
1	“Source List”	open the source list. (page 13)
2	“ATT”	attenuate the sound. To cancel, touch again.
3	“Top”	open the top menu. (page 13)
4	◀◀/▶▶	tune manually. Touch and hold to skip frequencies continuously.
5	◀◀/▶▶	tune automatically.
6	“Band”	open the band list and change the band.
7	“Receive Menu”	open the receive menu, which contains the following. <ul style="list-style-type: none"> • “Mono”: Touch to activate the monaural mode if FM reception is poor. To restore stereo reception, select “OFF.” • “Local”: Touch to only tune into stations with stronger signal. To tune normal stations, select “OFF.” • “IF”: Touch to set to “Wide” to hear FM stereo broadcasts in stereo and with full frequency reception. To narrow the reception frequency automatically to eliminate noise, select “Auto.”
8	“Preset List”	list up stored stations, or store stations. (page 23)
9	“PTY List”	open the PTY list. (page 24)

Indications during reception

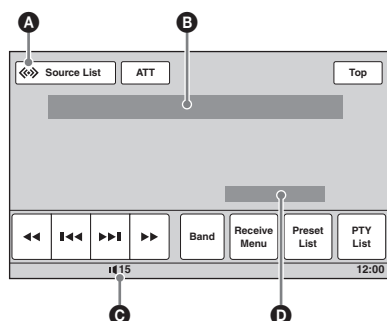

- A** Current source icon*1
- B** Band number, Preset number*2, Frequency/status
- C** Volume level*3
- D** Setting status (CSO, EQ7, RBE)

*1 Appears only when the controls are shown.

*2 Appears only when the station stored in memory is received.

*3 When ATT is activated,  appears.

Playing discs

Depending on the disc, some operations may be different or restricted.
Refer to the operating instructions supplied with your disc.

1 Press **▲** on the main unit.

The front panel opens automatically.

2 Insert the disc (label side up).

The front panel closes automatically, then playback starts.

If the DVD menu appears

Touch the item in the DVD menu directly.

You can also use the menu control panel which can be shown by touching the display in a place other than menu item area. Touch **◀/▲/▼/▶** to move the cursor, then "Enter" to confirm.

If the menu control panel does not appear by touching the display, use the card remote commander.

About the DVD menu

A DVD is divided into several sections, which make up a picture or music feature. These sections are called "titles." When you play a DVD that contains several titles, you can select a desired title using the DVD's top menu. For DVDs that allow you to select items such as subtitle/sound language(s), select these items using the DVD menu.

If the disc contains JPEG files

The slide show starts automatically.

To stop playback

Press **(SOURCE/OFF)** for 1 second.

Note

Discs in DTS format are not supported. The sound is not output if the DTS format is selected.

To eject the disc

1 Press **▲** on the main unit.

The front panel opens automatically, then the disc is ejected.

2 Press **▲** on the main unit to close the front panel.

Note

The front panel closes automatically after the caution alarm sounds.

continue to next page →

Playback controls

Touch the display if the playback controls are not shown.

Common to all discs/formats

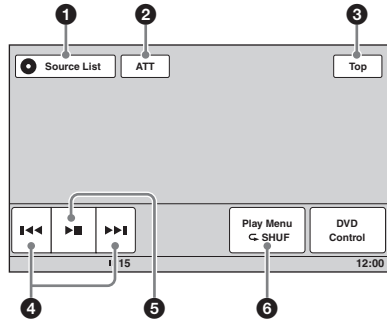

DVD

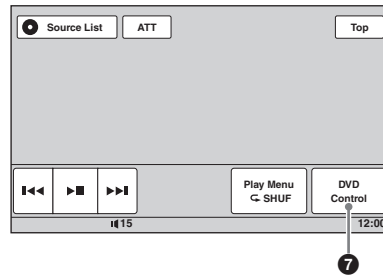

VCD

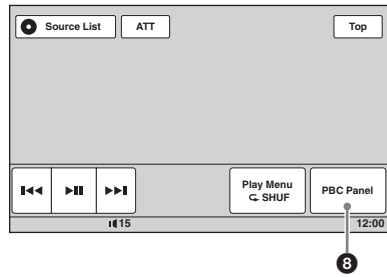

JPEG MPEG-4

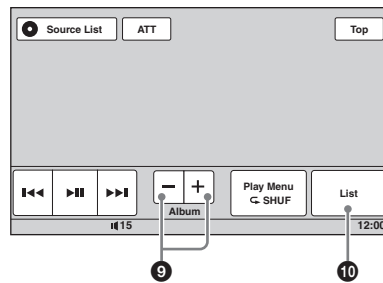

C D MP3 WMA AAC

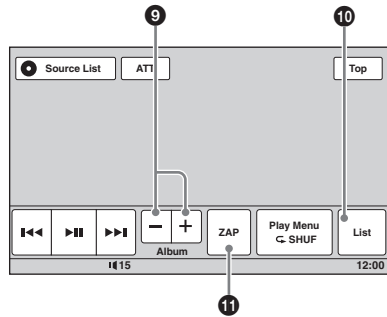

No.	Item	Touch to
1	“Source List”	open the source list. (page 13)
2	“ATT”	attenuate the sound. To cancel, touch again.
3	“Top”	open the top menu. (page 13)

No.	Item	Touch to
4	⏮/⏭	skip a chapter/track/scene/image/file. Touch and hold momentarily to reverse/fast-forward the video; and then repeatedly to switch the speed (× 2 → × 12 → × 120 → × 2...)*1. To cancel, touch ▶⏮. Touch and hold to reverse/fast-forward the audio track. During pause, touch and hold down ▶⏮ to play the video in slow motion. To cancel, release the key.
5	⏸	pause/resume play after pause.
6	“Play Menu”	open the play menu, which contains the following. <ul style="list-style-type: none"> • “Repeat/Shuffle” (page 26) • “Dolby D Level” (DVD VIDEO playback only) (page 25) • “Stereo” (VCD/CD/MP3/WMA/AAC playback only) (page 25) • “Image Turn” (JPEG playback only): Touch to rotate an image left/right. • “Audio” (MPEG-4 playback only) (page 25)
7	“DVD Control”	open the DVD control menu, which contains the following. <ul style="list-style-type: none"> • “Audio”: Touch repeatedly to select the audio language/format. (page 25)*2 • “Subtitle”: Touch repeatedly to turn off/select the subtitle language.*2*3 • “Angle”: Touch repeatedly to change the viewing angle.*2 • “Top Menu”: Touch to open the top menu on the DVD.*2 • “Menu”: Touch to open the menu on the disc.*2
8	“PBC Panel”	show the control panel for the PBC menu. (page 24)
9	“Album -/+”	skip an album (folder) of MP3/WMA/AAC/JPEG/MPEG-4.
10	“List”	list up tracks/images/video files. (page 34)
11	“ZAP”	enter the ZAPPIN mode. (page 35)

*1 The speed depends on the format or the recording method.

*2 Unavailable depending on the disc.

*3 When the 4-digit input prompt appears, input the language code (page 71) for the desired language.

Note

If the disc contains multiple file types, only the selected file type (audio/video/image) can be played. For details on how to select the file type, see “Selecting a file type” on page 34.

Notes on JPEG playback

- If a large-sized image is rotated, it may take longer to display.
- Progressive JPEG files cannot be displayed.

continue to next page →

Indications during playback

Touch the display to show the indications.

For audio discs, some indications are always shown during playback.

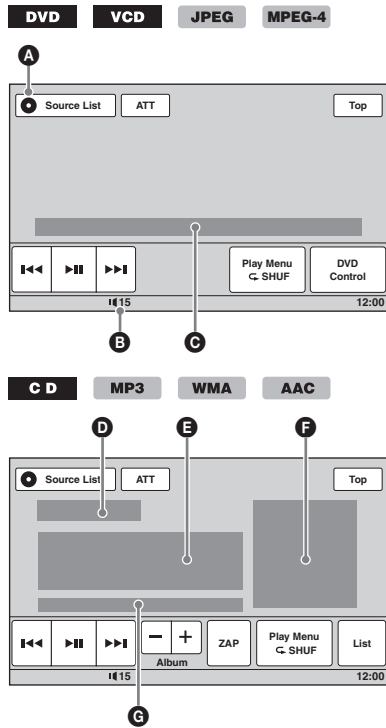

- A** Current source icon
- B** Volume level*¹
- C** Format, Playback status, Elapsed playback time*², Chapter/title/album (folder)/track number*³*⁴, Audio Format*⁵, Setting status (CSO, EQ7, RBE)
- D** Playback status, Elapsed playback time*²
- E** Track name, Album name, Artist name
- F** Album artwork display
- G** Format, Track number, Album number*⁶, Setting status (CSO, EQ7, RBE)

*¹ When ATT is activated,  appears.

*² During JPEG playback or VCD playback with the PBC function, no indication appears.

*³ Indications differ depending on the disc/format.

*⁴ When playing a VCD with the PBC function (page 24), no indication appears.

*⁵ DVD only.

*⁶ MP3/WMA/AAC only.

Advanced Operations — Radio

Storing and receiving stations

Caution

When tuning in stations while driving, use Best Tuning Memory (BTM) to prevent an accident.

Storing automatically — BTM

1 Touch “Source List,” then “Tuner.”

To change the band, touch “Band,” then select the desired band (“FM1,” “FM2,” “FM3,” “AM1” or “AM2”).

2 Touch “Preset List,” then “BTM.”

The unit stores stations in order of frequency in the preset list (“P1” to “P6”). A beep sounds when the setting is stored.

Storing manually

1 While receiving the station that you want to store, touch “Preset List.”

2 Touch “Memory,” then touch the number in the list (“P1” to “P6”).

The number and the confirmation display appear on the display.

3 Touch “Yes.”

The station is stored.

Note

If you try to store another station on the same number, the previously stored station will be replaced.

Receiving stored stations

1 Select the band, then touch “Preset List.”

2 Touch the desired number (“P1” to “P6”).

RDS

Overview

FM stations with Radio Data System (RDS) service send inaudible digital information along with the regular radio program signal.

Display items

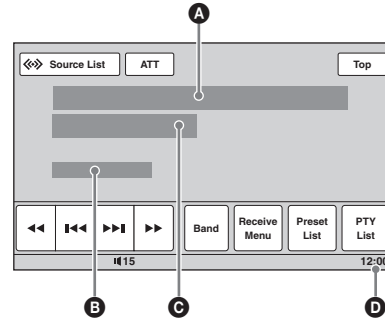

- A** Band number, Preset number, Frequency
- B** Stereo*1, RDS*2
- C** Program service name
- D** Clock display

*1 During FM reception.

*2 During RDS reception.

RDS services

This unit automatically provides RDS services as follows:

PTY (Program Types)

Displays the currently received program type. Also searches your selected program type.

CT (Clock Time)

The CT data from the RDS transmission sets the clock.

Notes

- Depending on the country/region, not all RDS functions may be available.
- RDS will not work if the signal strength is too weak, or if the station you are tuned to is not transmitting RDS data.

Selecting PTY

1 During FM reception, touch “PTY List.”

The PTY list appears if the station is transmitting PTY data.

To scroll the list, touch ◀▶.

2 Touch the desired program type.

The unit searches for a station broadcasting the selected program type.

To close the receive menu, touch “Receive Menu.”

Type of programs

“News” (News), “Information” (Information), “Sports” (Sports), “Talk” (Talk), “Rock” (Rock), “Classic Rock” (Classic Rock), “Adult Hits” (Adult Hits), “Soft Rock” (Soft Rock), “Top 40” (Top 40), “Country” (Country), “Oldies” (Oldies), “Soft” (Soft), “Nostalgia” (Nostalgia), “Jazz” (Jazz), “Classical” (Classical), “Rhythm and Blues” (Rhythm and Blues), “Soft R & B” (Soft Rhythm and Blues), “Language” (Foreign Language), “Religious Music” (Religious Music), “Religious Talk” (Religious Talk), “Personality” (Personality), “Public” (Public), “College” (College), “Weather” (Weather)

Notes

- You cannot use this function in countries/regions where no PTY data is available.
- You may receive a different radio program from the one you select.

Setting CT

1 Set “CT” to “ON” in setting (page 52).

Notes



- The CT function may not work even though an RDS station is being received.
- There might be a difference between the time set by the CT function and the actual time.

Advanced Operations — Discs

Using PBC functions — Playback control

VCD

The PBC menu interactively assists with operations while a PBC compatible VCD is played.

- While the unit is off, touch “Source List,” then .
- Touch “Visual.”
The visual setting menu appears.
- Touch ▲▼ to scroll, then “Video CD PBC” to set to “ON.”
- Start playing a PBC compatible VCD.
The PBC menu appears.
- Touch “PBC Panel.”
The menu control panel appears.
- Touch the number keys to select the desired item, then “Enter.”
- Follow the instructions in the menu for interactive operations.
To return to the previous display, press .
To hide the controls, touch “Close.”

Playing without the PBC function

Set “Video CD PBC” to “OFF” in the visual setting, then start playing a VCD.
The PBC menu does not appear during playback.

Notes

- The items on the menu, and operation procedures differ depending on the disc.
- During PBC playback, the track number, playback item, etc., do not appear in the playback display.
- Resume playback is unavailable during playback without PBC.

Tip

To resume PBC playback, stop playback by pressing **(SOURCE/OFF)** for 1 second, then start playing the VCD.

Configuring audio settings

Note

Discs in DTS format are not supported. The sound is not output if the DTS format is selected.

Changing the audio language/ format **DVD**

The audio language can be changed if the disc is recorded with multilingual tracks. You can also change the audio format when playing a disc recorded in multiple audio formats (e.g., Dolby Digital).

- 1 During playback, touch “DVD Control.”
- 2 Touch “Audio” repeatedly until the desired audio language/format appears.

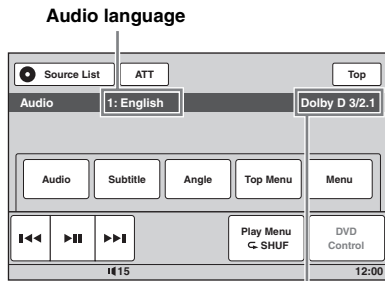

Audio format/channel numbers*

The audio language switches among the available languages.

When the 4-digit input prompt appears, input the language code (page 71) for the desired language.

When the same language is displayed two or more times, the disc is recorded in multiple audio formats.

* The format name and channel numbers appear as follows.

Example: Dolby Digital 5.1 ch

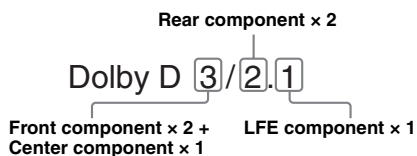

To close the DVD control menu, touch “DVD Control.”

Changing the audio channel

VCD

CD

MP3

WMA

AAC

MPEG-4

When playing VCD/CD/MP3/WMA/AAC/MPEG-4, you can select the right or left channel sound to listen through both right and left speakers.

The options are indicated below.

“2-Ch”: Standard stereo sound (default)

“L-Ch”: Left channel sound (monaural)

“R-Ch”: Right channel sound (monaural)

For VCD/CD/MP3/WMA/AAC

- 1 During playback, touch “Play Menu,” then “Stereo” repeatedly until the desired audio channel appears.

For MPEG-4

- 1 During playback, touch “Play Menu,” then “Audio” repeatedly until the desired audio channel appears.

To close the play menu, touch “Play Menu.”

Note

You may not be able to change the audio setting depending on the disc.

Tip

The operation by the card remote commander (pressing **AUDIO** repeatedly) is also available.

Adjusting the audio output level — Dolby D level **DVD**

You can adjust the audio output level for a DVD recorded in Dolby Digital format, to reduce the volume level differences between disc and source.

- 1 During playback, touch “Play Menu.”
- 2 Touch the “Adjust” box to set to “ON.”
- 3 Touch **-/+** repeatedly to adjust the output level.

The output level is adjustable in single steps, between -10 and +10.

To close the play menu, touch “Play Menu.”



Locking discs — Parental control

DVD *

* Excluding DVD-R/DVD-R DL/DVD-RW in VR mode.

You can lock a disc, or set playback restrictions according to a predetermined level such as viewer age. Restricted scenes can be blocked or replaced with different scenes when a parental control compatible DVD is played.

Activating parental control

- 1 While the unit is off, touch “Source List,” then .
- 2 Touch “Visual.”
The visual setting menu appears.
- 3 Touch  to scroll, then “DVD Parental Control.”
The password setting display appears.
- 4 Touch the number keys to enter your password, then “OK.”
- 5 To confirm, touch the number keys to reenter your password, then “OK.”
The setting is complete.

To delete an entered number, touch “Clear.”
To return to the previous display, touch “Back.”

Deactivating parental control



- 1 Follow steps 1 to 3 above.
The parental unlock display appears.
- 2 Touch the number keys to enter your current password.
“Parental Unlocked” appears, and the parental control is deactivated.

Changing the password

Deactivate the parental control, then activate again using the new password.

Changing the area and its movie rating level

The restriction levels can be set depending on the area and its movie ratings.

- 1 While the unit is off, touch “Source List,” then .
- 2 Touch “Visual.”
The visual setting menu appears.
- 3 Touch  to scroll, then “DVD Parental Area.”
When parental control is already activated, the display to enter your password appears. To change the setting, enter your password. The options appear.
- 4 Touch the desired area to apply its movie ratings.
When you select “Other,” enter the area code selecting from “Area code list” on page 71, using the number keys.
- 5 Touch “DVD Parental Rating.”
The options appear.
The lower the number, the stricter the restriction level.
- 6 Touch the desired rating.
The setting is complete.

To return to the previous display, touch “Back.”

Repeat and shuffle play

DVD **VCD** **C D** **MP3** **WMA**
AAC **JPEG** **MPEG-4**

- 1 During playback, touch “Play Menu,” then the “Repeat” or “Shuffle” box repeatedly until the desired option appears.

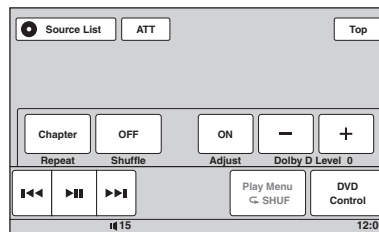

Repeat or shuffle play starts.

To close the play menu, touch “Play Menu.”

The repeat options and switching order of each disc/format are indicated below.

Disc/format	Options
DVD	<p>“OFF”: Returns to normal play mode.</p> <p>“Title”: Repeats the current title.</p> <p>“Chapter”: Repeats the current chapter.</p>
VCD *1 C D	<p>“OFF”: Returns to normal play mode.</p> <p>“Track”: Repeats the current track.</p>
MP3 WMA AAC MPEG-4	<p>“OFF”: Returns to normal play mode.</p> <p>“Track”: Repeats the current track/video file.</p> <p>“Album”: Repeats the current album (folder).</p>
JPEG	<p>“OFF”: Returns to normal play mode.</p> <p>“Image”: Repeats the current image.</p> <p>“Album”: Repeats the current album.</p>

The shuffle options and switching order of each disc/format are indicated below.

Disc/format	Options
DVD *2	<p>“OFF”: Returns to normal play mode.</p> <p>“Title”: Plays chapters in current title in random order.</p>
VCD *1 C D	<p>“OFF”: Returns to normal play mode.</p> <p>“Disc”: Plays tracks in current disc in random order.</p>
MP3 WMA AAC JPEG MPEG-4	<p>“OFF”: Returns to normal play mode.</p> <p>“Album”: Plays tracks/images/video files in current album (folder) in random order.</p>

*1 Available only when playing version 1.0/1.1 VCD, or version 2.0 VCD without PBC function.

*2 Excluding DVD-R/DVD-R DL/DVD-RW in VR mode.

Direct search play



You can directly locate a desired point by specifying the title number, chapter number, etc.

- 1 During playback, press the number buttons on the card remote commander to enter an item (track, title, etc.) number, then press **ENTER**. Playback starts from the beginning of the selected point.

The search items of disc/format are as follows.

DVD: Title or chapter*1
VCD*2/CD/MP3/WMA/AAC: Track
JPEG: Image
MPEG-4: File

*1 The search item depends on the setting.

*2 Available only when playing a VCD without PBC function.

Setting the search item (DVD only)

You can set the search item (title or chapter) for DVD playback.

- 1 Touch “Source List,” then .
- 2 Touch “Visual.” The visual setting menu appears.
- 3 Touch **▲/▼** to scroll, then “DVD Direct Search” to set to “Chapter” or “Title.” The setting is complete.

To return to the previous display, touch “Back.”

USB Device Operations

For details on the compatibility of your USB device, visit the support site.

Support site

<http://esupport.sony.com>
<http://www.xplodsony.com/>

- MSC (Mass Storage Class) and MTP (Media Transfer Protocol) type USB devices compliant with the USB standard can be used.
- Corresponding codec is MP3 (.mp3), WMA (.wma), AAC (.m4a), JPEG (.jpg) and MPEG-4 (.mp4).
- Backup of data in a USB device is recommended.

Notes

- Connect the USB device after starting the engine. Depending on the USB device, malfunction or damage may occur if it is connected before starting the engine.
- A large-sized file may take time to start playing back.

Notes on use

- Do not use USB devices so large or heavy that they may fall down due to vibration, or cause a loose connection.
- Do not leave a USB device in a parked car, as malfunction may result.
- This unit cannot recognize USB devices via a USB hub.

Notes on playback

- If a USB device contains multiple file types, only the selected file type (audio/video/image) can be played. For details on how to select the file type, see "Selecting a file type" on page 34.
- Displayed indications will differ, depending on the USB device, recorded format and settings. For details, visit the support site.
- The maximum number of displayable data is as follows.
 - folders (albums): 256
 - files (tracks): 2,000
- It may take time for playback to begin, depending on the amount of recorded data.
- During playback or fast-forward/reverse of a VBR (Variable Bit Rate) MP3/WMA/AAC file, elapsed playing time may not display accurately.
- Playback of a lossless compression file is not supported.

Playing a USB device

- 1 Remove the cap from the USB connector, and connect the USB device to the USB connector.

Playback starts automatically.

If a USB device is connected, to start playback, touch "Source List," then "USB/iPod."

For details on the location of the USB connector, see the supplied installation/connections manual.

About the controls and indications during playback

You can control USB playback in the same way as disc playback. For details, see "Playback controls" on page 20.

For details on indications during playback, see "Indications during playback" on page 22.

To stop playback

Press **(SOURCE/OFF)** for 1 second.

To disconnect the USB device

Stop playback, then disconnect.

Do not disconnect during playback, as data in the USB device may be damaged.

Repeat and shuffle play

- 1 During playback, touch "Play Menu," then the "Repeat" or "Shuffle" box until the desired option appears. Repeat or shuffle play starts.

The repeat options are as follows.

-
- "OFF": Returns to normal play mode.
 - "Track"/"Image"*1: Repeats the current track/image/video file.
 - "Album": Repeats the current album (folder).
 - "Drive"*2: Repeats the current drive.
-

The shuffle options are as follows.

-
- "OFF": Returns to normal play mode.
 - "Album": Plays tracks/images/video files in the current album (folder) in random order.
-

*1 When playing JPEG files.

*2 When two or more drives are created on the USB device.

To close the play menu, touch "Play Menu."

Enjoying music according to your mood — SensMe™

Sony's unique "SensMe™ channels" and "SensMe™ mood" features automatically group tracks by channel or mood, and allow you to enjoy music intuitively.

Before using the SensMe™ function

The following is the basic procedure required to enjoy the SensMe™ function on the unit.

① Installing "SensMe™ Setup" and "Content Transfer" in your computer

First install "SensMe™ Setup" and "Content Transfer" from the supplied CD-ROM.

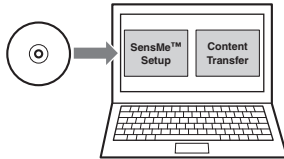

② Registering a USB device using "SensMe™ Setup"

Connect a USB device to your computer, and perform registration using "SensMe™ Setup" to enable the SensMe™ function on this unit.

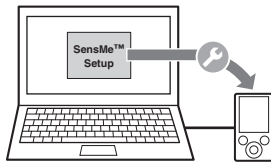

Tip

Registration can be performed either along with the installation procedure or after installation.

③ Transferring tracks to the USB device using "Content Transfer"

In order to group tracks by channel or mood, track sound patterns need to be analyzed by 12 TONE ANALYSIS, which is loaded in "Content Transfer."

With the USB device connected to your computer, drag and drop tracks from Windows Explorer or iTunes to "Content Transfer." Both analysis and transfer of tracks will be performed by "Content Transfer."

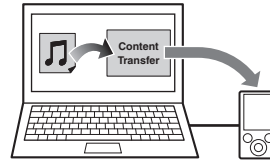

④ Connecting the USB device and enjoying the SensMe™ function on the unit

Connect the set up USB device. You can then enjoy "SensMe™ channels" or "SensMe™ mood" on this unit.

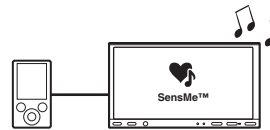

Installing "SensMe™ Setup" and "Content Transfer" in your computer

Use of the supplied software ("SensMe™ Setup" and "Content Transfer") is required to enable the SensMe™ function on this unit.

Install the software in your computer from the supplied CD-ROM.

1 Insert the supplied CD-ROM into your computer.

The Installation Wizard runs automatically.

2 Follow the on-screen instructions to complete the installation.

Registering a USB device using “SensMe™ Setup”

USB device registration is required to enable the SensMe™ function on the unit.

If registration is not performed along with the installation procedure, follow the steps below.

- 1 Start “SensMe™ Setup” on your computer.**
- 2 Connect a USB device to your computer.**
- 3 Complete registration following the on-screen instructions.**

Tip

If you connect a registered USB device containing analyzed tracks, the USB device can be unregistered again.

Transferring tracks to the USB device using “Content Transfer”

To enable the SensMe™ function on this unit, tracks need to be analyzed and transferred to the registered USB device, using “Content Transfer.”

- 1 Connect the registered USB device to your computer.**

For “WALKMAN,” connect with the MTP mode.

For USB devices other than “WALKMAN,” connect with the MSC mode.

“Content Transfer” starts automatically.

If a message appears, follow the on-screen instructions to proceed.

- 2 Drag and drop tracks from Windows Explorer or iTunes to “Content Transfer.”**

The analysis and transfer of tracks start.

For details on operations, see the Help of “Content Transfer.”

Note

The track analysis by 12 TONE ANALYSIS may take time, depending on the computer environment.

Playing tracks in the channel — SensMe™ channels

“SensMe™ channels” automatically group tracks into channels by their tunes. You can select and play a channel that fits your mood, activity, etc.

- 1 Connect a USB device set up for the SensMe™ function.**
- 2 Touch “Source List,” then “SensMe™.”**
- 3 Touch “channel.”**
The channel list appears.

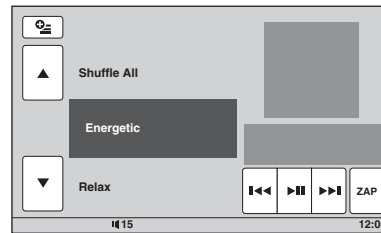

- 4 Touch ▲/▼ to scroll the channel list.**
Playback of the first track in the current channel starts from the track’s most melodic or rhythmical section*.
* May not be detected correctly.
- 5 Touch the desired channel.**
Playback of tracks in the selected channel starts.

Note

Depending on the track, it may not be detected correctly or may be grouped in a channel not suited to the track’s mood.

Tip

Tracks are played in random order. The order will vary at each channel selection.

Channel list

“Morning” (5:00 AM – 9:59 AM)

“Daytime” (10:00 AM – 3:59 PM)

“Evening” (4:00 PM – 6:59 PM)

“Night” (7:00 PM – 11:59 PM)

“Midnight” (12:00 AM – 4:59 AM)

One of above channels appears according to the current time.

Set the clock (page 59) for the channel to be displayed accurately.

“Shuffle All”

Plays all analyzed tracks in random order.

“Energetic,” “Relax,” “Mellow,” “Upbeat,”

“Emotional,” “Lounge,” “Dance,”

“Extreme”

Plays tracks according to the music type.

“Freeway,” “Chillout Drive,” “Party Ride,”

“Morning Commute,” “Goin’ Home,”

“Weekend Trip,” “Midnight Cruise”

Plays tracks that are suitable while driving.

Controls and indications during “SensMe™ channels” playback

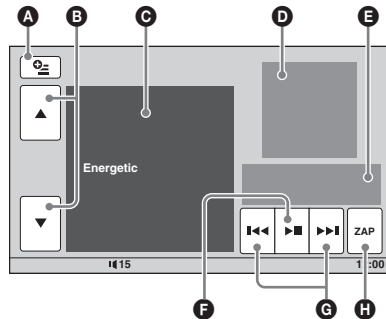

- A** To show the control keys: “Source List,” “ATT,” “Top.” (page 20)
- B** To scroll the list and select another channel.
- C** Indicates the current channel.
- D** Indicates the album artwork display.
- E** Indicates the elapsed playback time, track name, artist name.
- F** To pause/resume play after pause.
- G** To skip a track.
- H** To enter the ZAPPIN mode. (page 35)
During ZAPPIN playback of “SensMe™ channels,” the most melodic or rhythmical sections* of the tracks are played.

* May not be detected correctly.

Playing tracks in the mood map — SensMe™ mood

“SensMe™ mood” distributes tracks as dots on a two-axis mood map, based on the characteristics of the individual tracks.

By touching the point on the map according to your mood, a circle appears around the touched point, and the tracks inside the circle are played.

- 1** Connect a USB device set up for the SensMe™ function.
- 2** Touch “Source List,” then “SensMe™.”
- 3** Touch “mood.”
The two-axis mood map appears.

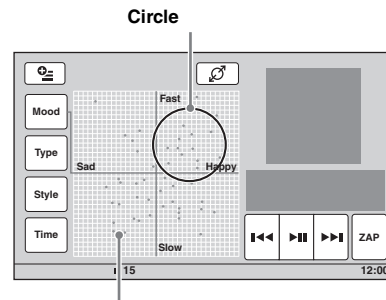

Dots representing tracks

- 4** Touch the desired point on the map.
A circle appears around the touched point, and playback of tracks inside the circle starts. Playback of the first track starts from its most melodic or rhythmical section*.

* May not be detected correctly.

Note

Depending on the track, it may not be detected correctly or may be mapped in the position not suited to the track’s mood.

Tips

- In the mood map, the currently played track is indicated as a green dot.
- Tracks are played from the circle’s center outward.

Controls and indications during "SensMe™ mood" playback

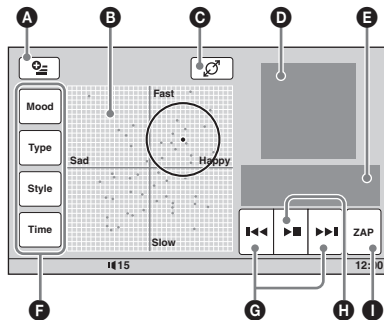

- A** To show the control keys: "Source List," "ATT," "Top;" (page 20)
- B** To move the circle and regroup tracks.
- C** To change the size of the circle: small, medium or large.
- D** Indicates the album artwork display.
- E** Indicates the elapsed playback time, track name, artist name.
- F** To change parameters on the horizontal axis.
- G** To skip a track.
- H** To pause/resume play after pause.
- I** To enter the ZAPPIN mode. (page 35)
During ZAPPIN playback of "SensMe™ mood," the most melodic or rhythmical sections* of the tracks are played.

* May not be detected correctly.

Changing parameters on the horizontal axis

In the mood map, you can change parameters on the horizontal axis. Tracks are remapped according to the characteristics of the parameters.

Touch	To change parameters to
"Mood"	"Sad" – "Happy"
"Type"	"Acoustic" – "Electronic"
"Style"	"Soft" – "Hard"
"Time"	"Morning" – "Midnight"

iPod Operations

For details on the compatibility of your iPod, see "About iPod" on page 63 or visit the support site.

Support site

<http://esupport.sony.com>
<http://www.xplodsony.com/>

In this manual, "iPod" is used as a general reference for the iPod functions on the iPod and iPhone, unless otherwise specified by the text or illustrations.

Playing an iPod

- 1 Reduce the volume on this unit.**
- 2 Remove the cap from the USB connector, and connect the iPod to the USB connector.**

Use of the optional USB connection cable RC-200IPV is recommended.*1

For details, see the supplied installation/connections manual.

The following display appears on the iPod screen*2, then playback starts from the item last played.

If an iPod is already connected, to start playback, touch "Source List," then "USB/iPod."



*1 To play videos of iPod with video, use of the RC-200IPV is required.

*2 May not appear in the case of an iPod touch or iPhone being connected, or when the iPod was last played back using passenger control.

- 3 Adjust the volume on this unit.**

About the controls and indications during playback

You can control iPod playback in the same way as disc playback. For details, see "Playback controls" on page 20.

For details on indications during playback, see "Indications during playback" on page 22.

To stop playback

Press **(SOURCE/OFF)** for 1 second.

To disconnect the iPod

Stop playback, then disconnect.
Do not disconnect during playback, as data in the iPod may be damaged.

About the resumming mode

When the iPod currently playing is connected to the dock connector, the mode of this unit changes to resumming mode and playback starts in the mode set by the iPod.

In the resumming mode, repeat/shuffle play is not available.

Caution for iPhone

When you connect an iPhone via USB, telephone volume is controlled by iPhone itself. In order to avoid sudden loud sound after a call, do not increase the volume on the unit during a telephone call.

Notes

- With an iPod connected to the USB connector, you cannot select an auxiliary device connected to the AUX1 VIDEO IN terminal.
- This unit cannot recognize iPod via a USB hub.

Tips

- When the ignition key is turned to the ACC position with the unit on, the iPod will be recharged.
- If the iPod is disconnected during playback, "USB device is not connected." appears in the display of the unit.

Setting the play mode

You can set one of the following play modes.

For audio playback

"Album," "Track," "Genre," "Playlist," "Artist," "Podcast"*

For video playback

"Movie," "Rental," "TV Show," "Music Video," "Playlist," "Podcast"*

* May not appear depending on iPod setting.

1 During playback, touch **"List."**

2 Touch **"Music"** or **"Video."**

3 Touch the desired play mode.

To start playback, touch the desired item(s) in the list.

To scroll the list, touch ▲/▼.

To skip items of the selected play mode

During playback, touch -/+ of the selected play mode.

Repeat and shuffle play

1 During playback, touch **"Play Menu,"** then the **"Repeat"** or **"Shuffle"** box until the desired option appears.

Repeat or shuffle play starts.

To close the play menu, touch **"Play Menu."**

The repeat options are as follows.

For audio playback

"OFF": Returns to normal play mode.

"Track": Repeats the current track.

"Album"/"Podcast"/"Artist"/"Playlist"/

"Genre"*: Repeats the current item of the selected play mode.

For video playback

"OFF": Returns to normal play mode.

"Track": Repeats the current video.

"Rental"/"TV Show"/"Music Video"/

"Playlist"/"Podcast"*: Repeats the current item of the selected play mode.

The shuffle options are as follows.

For audio playback

"OFF": Returns to normal play mode.

"Album"/"Podcast"/"Artist"/"Playlist"/

"Genre"*: Plays tracks of the selected play mode in random order.

"Device": Plays all tracks in an iPod in random order.

* Differs depending on the selected play mode.

Note

Displayed options may not conform to actual operation.

Operating an iPod directly — Passenger control

You can directly operate an iPod connected to this unit.

- 1 During playback, touch “Play Menu,” then the “Passenger Control” box to set to “ON.”

Deactivating the passenger control

Touch the “Passenger Control” box to set to “OFF.”

The play mode changes to resuming mode.

To close the play menu, touch “Play Menu.”

Notes

- In the passenger control mode, the playback controls on this unit are always shown. To hide the controls, touch the display in a place other than the playback control key area.
- To output video to this unit, you need to activate the video output of iPod.
- The volume can be adjusted only by this unit.
- The repeat setting will be off if the passenger control mode is canceled.

Useful Functions

Listing up tracks/images/video files — List

Selecting a track/image/video file

CD

MP3

WMA

AAC

JPEG

MPEG-4

You can list up albums/folders/tracks/images/video files, and select a desired one to play. This function is convenient especially for the disc in MP3/WMA/AAC/JPEG/MPEG-4 format or USB device containing many albums/tracks, etc.

- 1 During playback, touch “List.”

The list of categories or files in the currently played item appears.

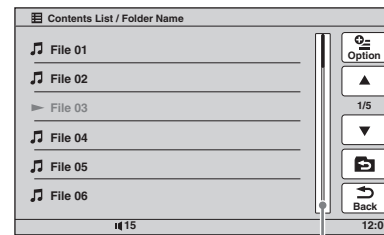

Page position bar

To move to the upper level, touch .

To scroll the list, touch .

To jump pages, touch the page position bar.

- 2 Touch the desired item.

Playback starts.

Selecting a file type

MP3

WMA

AAC

JPEG

MPEG-4

If the disc/USB device contains multiple file types, only the selected file type (audio/video/image) can be played. The playback priority order of file type is initially set to audio, video, then image (e.g., if the disc contains video files and image files, only video files are played). You can select the file type to list up, then select the desired file to play.

- 1 During playback, touch “List.”

- 2 Touch “Option,” then “Audio,” “Image” or “Video” to select the file type.

To close the option menu, touch “Close.”

- 3 Touch the desired file.

Playback of the selected file starts.

Searching a track by listening to track passages — ZAPPIN™

CD

MP3

WMA

AAC

While playing back short track passages in a disc or USB device in sequence, you can search for a track you want to listen to.

This function is convenient, for example, when searching for a track in shuffle or shuffle repeat mode.

1 During audio playback, touch “ZAP”

Playback starts from a passage of the next track.

The passage is played for the set time, and a beep sounds before the next passage starts.

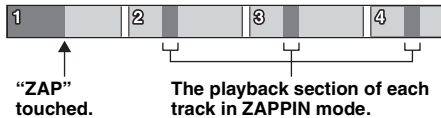

2 Touch “ZAP” when a track you want to listen is played back.

The track that you select returns to normal play mode from the beginning.

To search a track by ZAPPIN mode again, repeat steps 1 and 2.

In the case of a USB device set up for the SensMe™ function

If you enter the ZAPPIN mode during playback of a USB device set up for the SensMe™ function, the most melodic or rhythmical sections* of tracks are played.

For details on setting up a USB device for the SensMe™ function, see “Enjoying music according to your mood — SensMe™” on page 29.

* May not be detected correctly.

Tips

- You can change the playback time (page 57), but cannot select the track passage to play back.
- You can deactivate the beep sound between track passages (page 57).

Using Gesture Command

You can perform frequently-used operations by drawing the following command stroke in the reception/playback display.

Draw	To
 a horizontal line (left to right)	Radio reception: seek forward stations. (The same as ►►.) <hr/> DVD playback: skip forward a chapter. (The same as ►►.) <hr/> MPEG-4/audio playback: skip forward a file/track. (The same as ►►.)
 a horizontal line (right to left)	Radio reception: seek backward stations. (The same as ◀◀.) <hr/> DVD playback: skip backward a chapter. (The same as ◀◀.) <hr/> MPEG-4/audio playback: skip backward a file/track. (The same as ◀◀.)
 a vertical line (upwards)	Radio reception: receive stored stations (go forward). <hr/> DVD playback: fast-forward the video. <hr/> MPEG-4/audio playback: skip forward an album (folder). (The same as “Album” +.)
 a vertical line (downwards)	Radio reception: receive stored stations (go backward). <hr/> DVD playback: reverse the video. <hr/> MPEG-4/audio playback: skip backward an album (folder). (The same as “Album” -.)

To view the instructions on Gesture Command

Touch when it is shown in the top right corner of the display.

Handsfree Calling and Audio Streaming — Bluetooth

Before using the Bluetooth function

For details on compatibility of your device, visit the support site.

Support site

<http://esupport.sony.com>
<http://www.xplodsony.com/>

Basic procedure of the Bluetooth function

1 Pairing

When connecting Bluetooth devices for the first time, mutual registration is required. This is called "pairing." This registration (pairing) is required only for the first time, as this unit and the other devices will recognize each other automatically from the next time.



Note

If you delete the device registration from this unit, you need to perform pairing again.

2 Connection

After pairing is made, connect this unit and the Bluetooth device. Depending on the device, connection is automatically made along with the pairing.



3 Handsfree calling/Audio streaming

You can make/receive a handsfree call, or listen to audio through this unit.

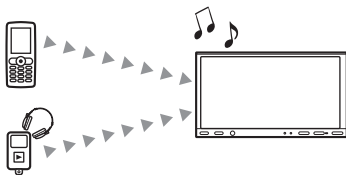

Bluetooth status indication



Bluetooth signal indicator: Lights up when the Bluetooth signal is on.

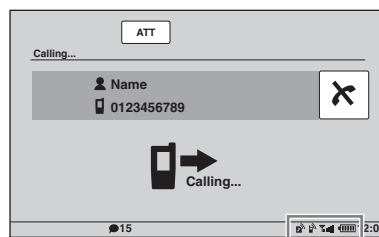

Bluetooth status indications

	<p>None: No device is connected for audio streaming purpose.</p> <p>Flashing: Connection is in progress.</p> <p>Lit: Connected to a device.</p>
	<p>None: No cellular phone is connected for handsfree calling purpose.</p> <p>Flashing: Connection is in progress.</p> <p>Lit: Connected to a cellular phone.</p>
	Signal strength status of connected cellular phone.
	Remaining battery status of connected cellular phone.

Installing the external microphone XA-MC10

To capture your voice during handsfree calling, you need to install the external microphone XA-MC10 (supplied).

For details on how to connect the microphone, see the supplied installation/connections manual.

Pairing

Pairing is required only the first time you connect to a Bluetooth device (cellular phone, etc.).*¹

To pair this unit to a Bluetooth device, you need to enter the same passkey*² on this unit and on the Bluetooth device. The passkey is a 4 or more digit number (e.g., 0000), which is either selected by yourself or determined by the Bluetooth device. For details, see the manual of the Bluetooth device.

*¹ If you delete the device registration from this unit, you need to perform pairing again.

*² Passkey may be called "passcode," "PIN code," "PIN number," "password," etc., depending on the Bluetooth device.

Tip

You can pair up to 9 devices.

Searching from this unit

Check that the other Bluetooth device is set to allow for searching (discoverable) beforehand.

1 Select the Bluetooth source.

To select Bluetooth Phone, press **(TOP)**, then touch "BT Phone" in the top menu.

To select Bluetooth Audio, touch "Source List," then "BT Audio."

2 Touch "BT Menu."

The Bluetooth setting menu appears.



3 Touch "Search."

Search of connectable Bluetooth devices starts.*¹

After search is complete, the list of detected devices*² appears.

*¹ Search time varies depending on the number of connectable devices.

*² The name or address (if name is unavailable) of detected devices are displayed.

4 Touch the device to connect.

5 Select the connection type.

Touch "Handsfree Connect" to use for handsfree calling.



Touch "Audio Connect" to use for audio streaming.

Pairing start and the passkey input display appears.

6 Touch the number keys to enter the passkey, then "OK."

Perform the required operation also on the other Bluetooth device.

Pairing is complete and this unit is connected to the other Bluetooth device.

When connection is made successfully,  or  appears at the bottom of the display.

Searching from the Bluetooth device

The procedure to search for this unit from the other Bluetooth device is explained below.

1 Select the Bluetooth source.

To select Bluetooth Phone, press **(TOP)**, then touch "BT Phone" in the top menu.

To select Bluetooth Audio, touch "Source List," then "BT Audio."

2 Touch "BT Menu."

The Bluetooth setting menu appears.

3 Touch "Signal," then "Yes" to set "Signal" to "ON."

The Bluetooth signal of this unit is activated.

4 Touch "Discoverable" to set to "Show."

The unit is ready to be detected by the other Bluetooth device.

continue to next page →

5 Start searching for this unit from the other Bluetooth device.

After search is complete, this unit appears as "XPLOD"* in the list of the other Bluetooth device.

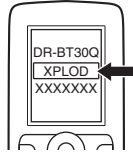

* Can be changed in the Bluetooth setting (page 45).



After you perform the required operation on the other Bluetooth device, the passkey input display appears on this unit.

6 Touch the number keys to enter the passkey, then "OK."

Pairing is complete and this unit is connected to the other Bluetooth device.

When connection is made successfully,  or  appears at the bottom of the display.

Notes

- While connecting to a Bluetooth device, this unit cannot be detected from another device. To enable detection, disconnect the current connection and search for this unit from another device.
- Depending on the device, searching from this unit may not be possible. In this case, search for this unit from the other device.
- If you search for this unit and the other device mutually at the same time, this unit will not recognize the other device.
- It may take time to search or connect.
- Depending on the device, the connection confirmation display appears before inputting the passkey.
- The time limit for inputting the passkey differs depending on the device.
- This unit cannot be connected to a device that supports only HSP (Head Set Profile).

Connecting

When the ignition is switched to on with the Bluetooth signal activated, this unit searches for the last connected Bluetooth device, and connection is made automatically if possible.

This chapter explains how to connect manually to registered Bluetooth devices.

Before starting, be sure to activate the Bluetooth signal both on this unit (page 45) and the other Bluetooth device.

1 Select the Bluetooth source.

To select Bluetooth Phone, press **(TOP)**, then touch "BT Phone" in the top menu.

To select Bluetooth Audio, touch "Source List," then "BT Audio."

2 Touch "BT Menu."

The Bluetooth setting menu appears.

3 Touch "Device List."

The list of registered Bluetooth devices appears.

To scroll the list, touch **▲/▼**.



4 Touch the device to connect.

5 Select the connection type.

Touch "Handsfree Connect" to use for handsfree calling.

Touch "Audio Connect" to use for audio streaming.



Connection is complete.

When connection is made successfully,  or  appears at the bottom of the display.

In the device list, the currently connected device is indicated by the icon at the head of its name.

To connect from the other Bluetooth device

Operate the other Bluetooth device to connect to this unit.

When connection is made successfully,  or  appears at the bottom of the display.

To disconnect

1 Follow steps 1 to 3 above.

2 Touch the currently connected device, then "Handsfree Disconnect" or "Audio Disconnect."

To delete all registrations

1 Follow steps 1 to 3 above.

2 Touch "Delete All," then "Yes" in the confirmation display.

Note

If connection is made during audio streaming, noise may occur over playback sound.

Tip

You can connect a cellular phone for audio streaming purpose if it supports A2DP (Advanced Audio Distribution Profile).

Handsfree calling

Once the unit is connected to the cellular phone, you can make/receive handsfree calls by operating this unit.

Making calls

By dialing a phone number

1 Press **(TOP)**, then touch “BT Phone” in the top menu.

The Bluetooth Phone display appears.

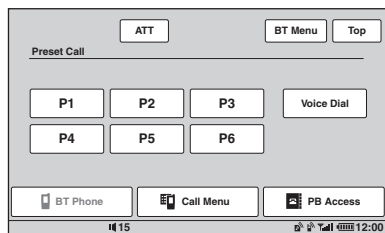

2 Touch “Call Menu,” then “Dial.”

The number input display appears.

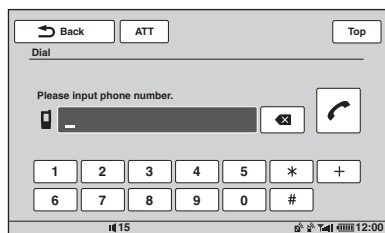

3 Touch the number keys to enter the phone number, then .

To delete an entered number, touch . The call is made and the calling display appears until the other party answers.

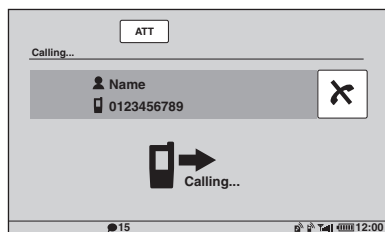

By the phonebook

For details on how to manage the phonebook data, see “Phonebook management” on page 41.

1 Press **(TOP)**, then touch “BT Phone” in the top menu.

The Bluetooth Phone display appears.

2 Touch “Call Menu,” then “Phonebook.”

The phonebook appears.

3 Select the desired contact.

- ① In the initial list, touch the initial of the contact.
- ② In the name list, touch the name of the contact.
- ③ In the number list, touch the phone number.

The contact confirmation display appears.

4 Touch “Call.”

The call is made and the calling display appears until the other party answers.

Tips

- If no phonebook data is yet stored on this unit, the display to add a contact appears after step 2 above. For details on how to add a contact, see “To add a contact by entering the name and number” on page 41.
- You can also browse the phonebook of the connected cellular phone on this unit and make a call (page 42).

By the call history



The unit stores the last 20 calls, allowing you to select one quickly from the list.

1 Press **(TOP)**, then touch “BT Phone” in the top menu.

The Bluetooth Phone display appears.

2 Touch “Call Menu,” then “Recent Call.”

The list of call history appears.

To scroll the list, touch /.

3 Touch the desired item in the list.

The contact confirmation display appears.

4 Touch “Call.”

The call is made and the calling display appears until the other party answers.

continue to next page →

By the preset dial

You can store up to 6 contacts in the preset dial. For details on how to store, see “Preset dial” on page 44.

- 1 Press **(TOP)**, then touch “BT Phone” in the top menu.
The Bluetooth Phone display appears.
- 2 Touch the number in the list (“P1” to “P6”).
The contact confirmation display appears.
- 3 Touch “Yes.”
The call is made and the calling display appears until the other party answers.

By the voice dial function

You can make a call using the voice tag stored on the connected cellular phone.

- 1 Press **(TOP)**, then touch “BT Phone” in the top menu.
The Bluetooth Phone display appears.
- 2 Touch “Voice Dial.”
- 3 Say the voice tag stored on the cellular phone.
Your voice is recognized, then the call is made.
The calling display appears until the other party answers.

Notes

- Say the voice tag in the same way as you stored it on the cellular phone.
- If the voice dial function is activated on the connected cellular phone, it may not work by this unit.
- Do not use the voice dial function on the cellular phone while it is connected to this unit.
- Noises such as the engine running may interfere with sound recognition. In order to improve recognition, operate under conditions where noise is minimized.
- Voice dial may not work depending on the recognition specification of the cellular phone. For details, visit the support site.

To adjust the talker's voice volume

Press **(VOL)** +/- while making a call. The level of talker's voice volume will be stored into memory, independently from the regular volume level.

Receiving calls

With the unit connected to the cellular phone, you can receive a call in any status. The following display indicates an incoming call, along with the ring tone.

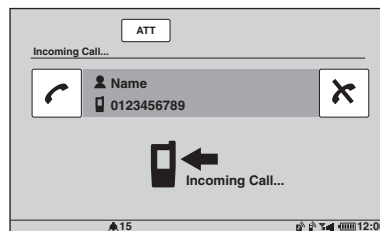

To answer the call

Touch .

To adjust the ring tone volume

Press **(VOL)** +/- while receiving a call. The level of ring tone volume will be stored into memory, independently from the regular volume level.

To reject a call

Touch .

Note

The ring tone and talker's voice are output only from front speakers.

Tips

- You can set to answer a call automatically (page 45).
- You can set to use the ring tone of the cellular phone or this unit (page 45).

Operations during a call

The following display appears during a call.

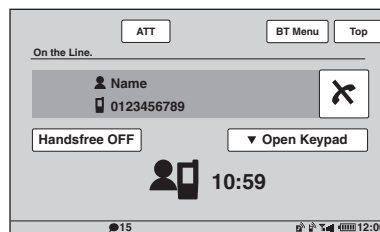

To adjust the talker's voice volume

Press **(VOL)** +/- during a call. The level of talker's voice volume will be stored into memory, independently from the regular volume level.

To send DTMF (Dual Tone Multiple Frequency) tones

Touch "Open Keypad," then the required number keys.

To transfer the current call to the cellular phone

Touch "Handsfree OFF."

To transfer back to the handsfree call, touch "Handsfree ON."

Note

Depending on the cellular phone, connection may be cut off when call transfer is attempted.

To adjust the volume for the other party

- 1 Touch "BT Menu."
- 2 Touch ▲/▼ to scroll, then "MIC Gain."
- 3 Touch +/- to adjust the level.
The level is adjustable in single steps, between -2 and +2.
- 4 Touch "Back" repeatedly to return to the previous displays.

To end a call

Touch ✕.

Phonebook management

You can store up to 300 contacts in the phonebook and up to 5 phone numbers can be registered to each contact.

Notes

- Downloaded phonebook data from a cellular phone cannot be overwritten by subsequent data. However, some data (name, etc.) may be duplicated as a result.
- Phonebook data may be lost if this unit is damaged.
- When disposing of this unit, delete the phonebook data by initializing (page 45).

Storing phonebook data

To download from a cellular phone

If the connected cellular phone supports PBAP (Phone Book Access Profile), you can download phonebook data and store on this unit.

- 1 Press (TOP), then touch "BT Phone" in the top menu.
The Bluetooth Phone display appears.
- 2 Touch "PB Access."
The phonebook access menu appears.

3 Touch "Access" to select the memory where phonebook data is stored.

To download the data in a cellular phone's internal memory, set to "From Memory."

To download the data on SIM, set to "SIM."

4 Touch "Phonebook Download."

When downloading is complete, "Complete" appears and the phonebook data is stored on this unit.

To receive from a cellular phone

You can send phonebook data from the connected cellular phone and receive it on this unit.

- 1 Press (TOP), then touch "BT Phone" in the top menu.
The Bluetooth Phone display appears.
- 2 Touch "Call Menu," then "Receive Phonebook."
This unit is ready for receiving phonebook data.
- 3 Send the phonebook data by operating the connected cellular phone.
When receiving is complete, "Complete" appears and the phonebook data is stored on this unit.

To add a contact by entering the name and number

- 1 Press (TOP), then touch "BT Phone" in the top menu.
The Bluetooth Phone display appears.
- 2 Touch "Call Menu," then "Phonebook."
The phonebook appears.
- 3 Touch "Add Contact."
The contact registration display appears.

- 4 Touch "Entry Name."
The name input display appears.

continue to next page →

5 Touch the character keys to enter the name, then "OK."

For details on how to use the keyboard, see "About the keyboard to edit the name" on page 43.

The contact registration display reappears.

6 Touch "Entry Number."

The number input display appears.

7 Touch the number keys to enter the phone number, then "OK."

The phone number type selection display appears.

8 Touch the desired phone number type.

The contact registration display reappears.

To enter other phone numbers, repeat steps 6 to 8.

9 Touch "Add to Phonebook?"

The contact is added to the phonebook.

To add a contact from the call history**1 Press (TOP), then touch "BT Phone" in the top menu.**

The Bluetooth Phone display appears.

2 Touch "Call Menu," then "Recent Call."

The list of call history appears.

To scroll the list, touch ▲/▼.

3 Touch the item to add to the phonebook.

The contact confirmation display appears.

4 Touch "Save to Phonebook."

The name input display appears.

5 Touch the character keys to enter the name, then "OK."

For details on how to use the keyboard, see "About the keyboard to edit the name" on page 43.

The contact is added to the phonebook.

Browsing a phonebook in a cellular phone

If the connected cellular phone supports PBAP (Phone Book Access Profile), you can browse its phonebook data on this unit.

You can also make a call to a contact or add the contact to this unit's phonebook.

1 Press (TOP), then touch "BT Phone" in the top menu.

The Bluetooth Phone display appears.

2 Touch "PB Access."

The phonebook access menu appears.

3 Touch "Access" to select the memory where phonebook data is stored.

To browse the data in a cellular phone's internal memory, set to "From Memory."

To browse the data on SIM, set to "SIM."

4 Touch "Phonebook Browsing."

The phonebook of the connected cellular phone appears.

5 Select the desired contact.

① In the initial list, touch the initial of the contact.

② In the name list, touch the name of the contact.

③ In the number list, touch the phone number.

The contact confirmation display appears.

To call the contact

Touch the phone number to call, then "Yes" in the confirmation display.

To add the contact to this unit's phonebook

Touch "Save to Phonebook," then "Yes" in the confirmation display.

Deleting phonebook data**To delete all phonebook data on this unit****1 Press (TOP), then touch "BT Phone" in the top menu.**

The Bluetooth Phone display appears.

2 Touch "Call Menu," then "Phonebook."

The phonebook appears.

3 Touch "Delete All."

The confirmation display appears.

4 Touch "Yes."

All phonebook data is deleted.

To delete an individual contact from the phonebook

- 1 Follow steps 1 to 2 above.
- 2 Select the contact to delete.
 - 1 In the initial list, touch the initial of the contact.
 - 2 In the name list, touch the name of the contact.
- 3 Touch **"Delete Contact."**
The confirmation display appears.
- 4 Touch **"Yes."**
The contact is deleted from the phonebook.

Editing a contact

- 1 Press **(TOP)**, then touch **"BT Phone"** in the top menu.
The Bluetooth Phone display appears.
- 2 Touch **"Call Menu,"** then **"Phonebook."**
The phonebook appears.
- 3 Select the contact to edit.
 - 1 In the initial list, touch the initial of the contact.
 - 2 In the name list, touch the name of the contact.
- 4 Touch the desired edit option.

Touch	To
"Edit Name"	edit the name of the contact. Enter the new name, then touch "OK."
"Add Number"	add the phone number to the contact. Enter the phone number, then touch "OK."
the phone number in the list	delete the selected phone number. Touch "Delete Number," then "Yes."

About the keyboard to edit the name

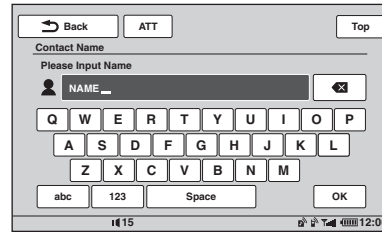

Touch	To
"ABC" or "abc"	change the case.
the desired character key	enter the character.
"123"	switch to the numeric keyboard.
the desired number/symbol key	enter the number/symbol.
"Space"	enter a space.
✕	delete a character.
"OK"	complete the name edit.

Call data management

Call history

You can delete the items in the call history.

To delete all items in the call history

- 1 Press **(TOP)**, then touch **"BT Phone"** in the top menu.
The Bluetooth Phone display appears.
- 2 Touch **"Call Menu,"** then **"Recent Call."**
The list of call history appears.
- 3 Touch **"Delete All."**
The confirmation display appears.
- 4 Touch **"Yes."**
All items in the call history are deleted.

continue to next page →

To delete an individual item in the call history

- 1 Follow steps 1 to 2 above.
- 2 In the list, touch the item to delete.
The contact confirmation display appears.
- 3 Touch "Delete Number."
The confirmation display appears.
- 4 Touch "Yes."
The selected item is deleted from the call history.

Preset dial

You can store contacts in the phonebook or call history into the preset dials.

To store from the phonebook

- 1 Press **(TOP)**, then touch "BT Phone" in the top menu.
The Bluetooth Phone display appears.
- 2 Touch "Call Menu," then "Phonebook."
The phonebook appears.
- 3 Select the contact to store in the preset dial.
 - 1 In the initial list, touch the initial of the contact.
 - 2 In the name list, touch the name of the contact.
 - 3 In the number list, touch the phone number.
The contact confirmation display appears.
- 4 Touch "Preset Memory," then the desired preset number ("P1" to "P6").
The contact is stored in the selected preset number.

To store from the call history

- 1 Press **(TOP)**, then touch "BT Phone" in the top menu.
The Bluetooth Phone display appears.
- 2 Touch "Call Menu," then "Recent Call."
The list of call history appears.
To scroll the list, touch ▲/▼.
- 3 Touch the desired item in the list.
The contact confirmation display appears.
- 4 Touch "Preset Memory," then the desired preset number ("P1" to "P6").
The contact is stored in the selected preset number.

To change the registration of the preset dial

Follow the procedure above and overwrite a registered preset dial.

Locking the personal information

To prevent unauthorized access to personal information, you can lock call data by setting a 4-digit code.

Once locked, you need to enter the code to access the items in the call menu.

- 1 Press **(TOP)**, then touch "BT Phone" in the top menu.
The Bluetooth Phone display appears.
- 2 Touch "Call Menu," then "PIM Security Lock / Unlock."
The code setting display appears.
- 3 Touch the number keys to enter your code, then "OK."
- 4 To confirm, touch the number keys to reenter your code, then "OK."
The setting is complete.

To delete an entered number, touch "Clear."
To return to the previous display, touch "Back."

Unlocking the call data

- 1 Follow steps 1 to 2 above.
The unlock display appears.
- 2 Touch the number keys to enter your code.
"Unlocked" appears, and the call data is unlocked.

Audio streaming

Listening to a Bluetooth device through this unit

If the other device supports A2DP (Advanced Audio Distribution Profile) of Bluetooth technology, you can listen to the playback sound through this unit.

- 1 Connect this unit and the Bluetooth device (page 38).
- 2 Reduce the volume on this unit.
- 3 Touch "Source List," then "BT Audio."
The Bluetooth Audio display appears.
- 4 Operate the other Bluetooth device to start playback.
- 5 Adjust the volume on this unit.

Operating the Bluetooth device with this unit

If the other device supports AVRCP (Audio Video Remote Control Profile) of Bluetooth technology, you can control the playback on this unit.

Operations can be performed in the same way as disc playback (page 20), except for the following.

Touch	To
"BT Menu"	open the Bluetooth setting menu (page 45).
-/+ in the "Level" box	reduce the volume level differences between this unit and the other Bluetooth device. The level is adjustable in single steps, between -8 and +18.

Notes

- The available operation differs depending on the Bluetooth device. Perform unavailable operations on the Bluetooth device.
- Depending on the Bluetooth device, it may be necessary to touch ►|| twice to start/pause the playback.
- During audio streaming, some indications such as track name, etc., may not appear on this unit.

Bluetooth settings

The Bluetooth settings can be configured in "BT Menu."

1 Select the Bluetooth source.

To select Bluetooth Phone, press (TOP), then touch "BT Phone" in the top menu.
To select Bluetooth Audio, touch "Source List," then "BT Audio."

2 Touch "BT Menu."

The Bluetooth setting menu appears.

3 Touch the desired item in the list and configure the setting.

The items in the Bluetooth setting menu are as follows.

"Signal"*1

Activates the Bluetooth signal: "ON," "OFF."

"Discoverable"*1 (page 37)

Allows the other Bluetooth device to search for this unit: "Show," "Hide."

"Device Name"*1

Changes the name of this unit displayed on the connected device. (Default setting: "XPLOD")
For details on basic operation of keyboard, see "About the keyboard to edit the name" on page 43.

"Search"*1 (page 37)

Searches for connectable Bluetooth devices.

"Device List"*1 (page 38)

Shows the list of registered devices; connects to a registered device; deletes all registrations.

"Auto Answer"*1

Answers an incoming call automatically.
– "Short": to answer automatically after 3 seconds.
– "Long": to answer automatically after 10 seconds.
– "OFF": to not answer automatically.

"Ringtone"*1*2

Uses the ring tone of this unit or the connected cellular phone: "Default," "Cellular."

"EC/NC Mode" (Echo Canceller/Noise Canceller Mode)

Reduces echo and noise in phone call conversations.

Set to "Mode 1" normally.

If the outgoing sound quality is unsatisfactory, set to "Mode 2" or "OFF."

"MIC Gain" (page 41)

Adjust the volume for the other party: -2 ~ +2.

"Initialize"*1

Initializes all Bluetooth-related settings. Touch "Yes" in the confirmation display.

*1 Cannot be configured during a handsfree call.

*2 Depending on the cellular phone, this unit's ring tone may be output even if set to "Cellular."

Note

For details on the setting of other Bluetooth devices, see their respective manuals.

Sound Adjustment

Selecting the sound quality — EQ7

You can select an equalizer curve from 7 music types (“Xplod,” “Vocal,” “Edge,” “Cruise,” “Space,” “Gravity,” and “Custom”).

- 1 During reception/playback, touch “Source List,” then .**
- 2 Touch “Sound.”**
The sound setting menu appears.
- 3 Touch “EQ7.”**
The options appear.
- 4 Touch the desired equalizer curve.**
The setting is complete.

To cancel the equalizer curve, select “OFF.”
To return to the previous display, touch “Back.”

Customizing the equalizer curve — EQ7 Tune

“Custom” of EQ7 allows you to make your own equalizer settings. You can adjust the level of 7 different bands: 62 Hz, 157 Hz, 396 Hz, 1 kHz, 2.5 kHz, 6.3 kHz, and 16 kHz.

- 1 During reception/playback, touch “Source List,” then .**
- 2 Touch “Sound,” then “EQ7.”**
- 3 Touch “Custom,” then “Tune.”**
The tuning display appears.

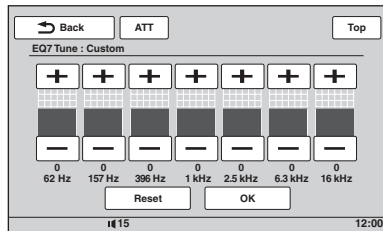

- 4 Touch +/- of each frequency to adjust their levels.**
The level is adjustable in single steps, between -8 and +8.
To restore the factory-set equalizer curve, touch “Reset.”
- 5 Touch “OK.”**
The setting is complete.

To return to the previous display, touch “Back.”

Tip

Other equalizer types are also adjustable.

Adjusting the sound characteristics

The sound balance between left and right speakers (“Balance”) and front and rear speakers (“Fader”) can be adjusted to your preference. You can also adjust the volume level of subwoofer if it is connected.

- 1 During reception/playback, touch “Source List,” then .**
- 2 Touch “Sound.”**
The sound setting menu appears.
- 3 Touch “Balance/Fader.”**
The setting display appears.

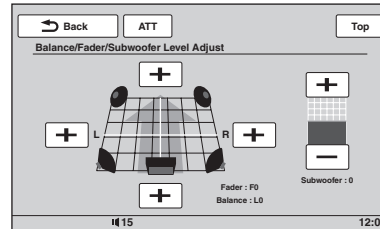

- 4 Touch + to adjust the balance/fader.**
The level is adjustable in single steps between L10 and R10 (Balance)/F10 and R10 (Fader).
- 5 Touch +/- to adjust the volume level of subwoofer.**
This setting is adjustable only when subwoofer is connected and “Subwoofer” is set to “ON” (page 54).
The level is adjustable in single steps, between -6 and +6.

To return to the previous display, touch “Back.”

Optimizing sound for the listening position — Intelligent Time Alignment

The unit can change the localization of sound by delaying the sound output from each speaker to suit your position, and simulate a natural sound field with the feeling of being in the center of it wherever you sit in the car.

The options for “Listening Position” are indicated below.

“**Front L**” (①): Front left
 “**Front R**” (②): Front right
 “**Front**” (③): Center front
 “**All**” (④): In the center of your car
 “**Custom**”: Precisely calibrated position (page 47)

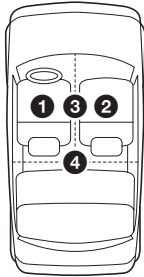

You can also set the approximate subwoofer position from your listening position if:

- the subwoofer is connected and “Subwoofer” is set to “ON” (page 54).
- the listening position is set to “Front L,” “Front R,” “Front” or “All.”

- 1 During reception/playback, touch “Source List,” then .**
- 2 Touch “Sound.”**
The sound setting menu appears.
- 3 Touch “Listening Position.”**
The setting display appears.
- 4 Set the listening position.**
Touch “Front L,” “Front R,” “Front,” “All” or “Custom.”
- 5 Set the subwoofer position.**
If you select “Front L,” “Front R,” “Front” or “All” in step 4 above, you can set the subwoofer position.
Touch “Near,” “Normal” or “Far.”
The setting is complete.

To cancel Intelligent Time Alignment, select “OFF.”

To return to the previous display, touch “Back.”

Precisely calibrating the listening position — Intelligent Time Alignment Tune

You can precisely calibrate your listening position from each speaker so that the sound delay reaches the listener more correctly.

Before starting, measure the distance between your listening position and each speaker.

- 1 During reception/playback, touch “Source List,” then .**
- 2 Touch “Sound,” then “Listening Position.”**
- 3 Touch “Custom,” then “Custom Tune.”**
The setting display appears.

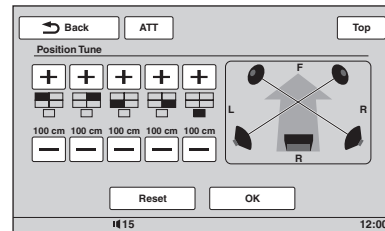

- 4 Touch +/- of each speaker to set the distance between your listening position and the speakers.**
The distance is adjustable in 2 cm ($1^{13}/_{16}$ in) steps, between 0 and 400 cm (0 and $13 \frac{1}{10}$ ft).
To restore the default setting, touch “Reset.”
- 5 Touch “OK.”**
The setting is complete.

To return to the previous display, touch “Back.”

Note

The setting is applied only after “OK” is touched.

Speaker configuration and volume setup

Creating a virtual center speaker — CSO

To fully enjoy surround sound, it is adequate to have 5 speakers (front left/right, rear left/right, center) and 1 subwoofer. CSO (Center Speaker Organizer) allows you to create a virtual center speaker even though a real center speaker is not connected.

- 1 During disc/USB playback, touch “Source List,” then .**
- 2 Touch “Sound.”**
The sound setting menu appears.
- 3 Touch “CSO.”**
The options appear.
- 4 Touch “CSO1,” “CSO2” or “CSO3.”**
The setting is complete.

To return to the previous display, touch “Back.”

Note

“CSO” is effective only when “Multi Ch Output” is set to “Multi” (page 56), as it is effective only for playback of multi-channel sources.

Using rear speakers as subwoofer — RBE

RBE (Rear Bass Enhancer) enhances the bass sound by applying the low pass filter setting (page 55) to rear speakers. This function allows rear speakers to work as a subwoofer even if it is not connected.

- 1 During reception/playback, touch “Source List,” then .**
- 2 Touch “Sound.”**
The sound setting menu appears.
- 3 Touch $\blacktriangle/\blacktriangledown$ to scroll, then “RBE.”**
The options appear.
- 4 Touch “RBE1,” “RBE2” or “RBE3.”**
The setting is complete.

To return to the previous display, touch “Back.”

Adjusting the speaker volume

You can adjust the volume level of each connected speaker.

The adjustable speakers are “Front R” (Front Right), “Front L” (Front Left), “Surround L” (Rear Left), “Surround R” (Rear Right) and “Subwoofer*.”

* Adjustable only when a subwoofer is connected and “Subwoofer” is set to “ON” (page 54).

- 1 While the unit is off, touch “Source List,” then .**
- 2 Touch “Sound.”**
The sound setting menu appears.
- 3 Touch $\blacktriangle/\blacktriangledown$ to scroll, then “Speaker Level.”**
The setting display appears.

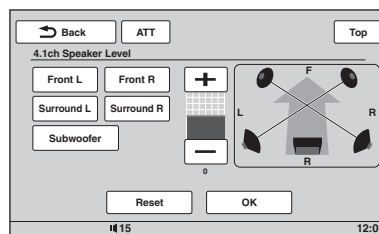

- 4 Touch the speaker, then +/- to adjust the level.**

Repeat this step to adjust all speaker volume. To restore the default setting, touch “Reset.”

To return to the previous display, touch “Back.”

Monitor Adjustment

Adjusting the monitor angle

You can adjust the monitor angle for best viewing.

- 1 Touch “Source List,” then .
- 2 Touch “General.”
The general setting menu appears.
- 3 Touch ▲/▼ to scroll, then “Monitor Angle.”
The setting display appears.
- 4 Touch +/- to adjust the angle.
The adjustment is stored.
The monitor retains the angle even after the front panel is opened and closed.

To return to the previous display, touch “Back.”

Touch panel calibration

Touch panel calibration is required if the touching position does not correspond with the proper item.

- 1 Touch “Source List,” then .
- 2 Touch “General.”
The general setting menu appears.
- 3 Touch ▲/▼ to scroll, then “Touch Panel Adjust.”
The setting display appears.
- 4 Touch the targets in sequence.
The calibration is complete.

To cancel calibration, touch “Cancel.”

Setting the background screen

You can select the screen theme, equalizer image and picture brightness for the background screen according to your preference.

- 1 Touch “Source List,” then .
- 2 Touch “Screen.”
The screen setting menu appears.
- 3 Touch “Screen Select.”
The options appear.
- 4 Select the screen theme.
Touch “Screen Theme,” then the desired type.
- 5 Select the equalizer image.
Touch “Equalizer,” then the desired type.
- 6 Select the picture brightness.
Touch “Day / Night mode,” then one of the following options.

“Auto”: Switches the brightness automatically when you turn the lights on. (Available only when the illumination control lead is connected.)

“Always Day”: Fixes the brightness suitable for day time use.

“Always Night”: Fixes the brightness suitable for night time use.

To return to the previous display, touch “Back.”

Selecting the picture quality — Picture EQ

You can select a picture quality suitable for the interior brightness of the car. The options are indicated below.

“Dynamic”: Vivid picture with bright, clear colors.

“Standard”: Standard picture quality.

“Theater”: Brightens the monitor; suitable for darkly-lit movies.

“Sepia”: Applies a sepia tone to the picture.

“Custom 1,” “Custom 2”: User-adjustable settings (page 50).

- 1 During video/image playback, touch “Source List,” then .
- 2 Touch “Screen.”
The screen setting menu appears.
- 3 Touch “Picture EQ.”
The options appear.
- 4 Touch the desired option.

To return to the previous display, touch “Back.”

Customizing the picture quality

The options "Custom 1" and "Custom 2" of Picture EQ allow you to make your own picture quality setting by adjusting the picture tones.

- 1 During video/image playback, touch "Source List," then .
- 2 Touch "Screen," then "Picture EQ."
- 3 Touch "Custom 1" or "Custom 2," then "Custom Tune."
The setting display appears.

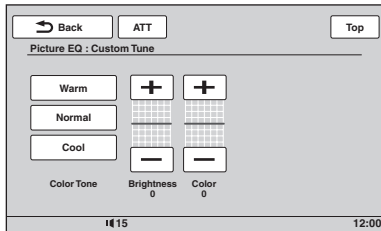

- 4 Touch "Warm," "Normal," or "Cool" to select "Color Tone."
- 5 Touch +/- of "Brightness" and "Color" to adjust their levels.

To return to the previous display, touch "Back."

Note

The picture quality of the rear view camera cannot be adjusted.

Selecting the aspect ratio

You can change the screen aspect ratio. The options are indicated below.

"Normal": Picture with 4:3 aspect ratio (regular picture).



"Wide": Picture with 4:3 aspect ratio enlarged to the left and right edges of the screen, with overflowing parts of top and bottom cut off to fill the screen.



"Full": Picture with 16:9 aspect ratio.



"Zoom": Picture with 4:3 aspect ratio enlarged to the left and right edges of the screen.



- 1 During video playback, touch "Source List," then .
- 2 Touch "Screen."
The screen setting menu appears.
- 3 Touch "Aspect."
The options appear.
- 4 Touch the desired option.

To return to the previous display, touch "Back."

Note

The screen aspect ratio of the rear view camera cannot be changed.

Settings

The setting menu includes the following categories.

- **“General”**: General settings (page 52)
- **“Sound”**: Sound settings (page 54)
- **“Screen”**: Screen settings (page 55)
- **“Visual”**: DVD and other playback settings (page 56)

Basic setting operation

You can set items in the menu by the following procedure.

E.g., when setting the demonstration

1 While the unit is off, touch “Source List,” then .

From the top menu, touch .
The setting menu appears.

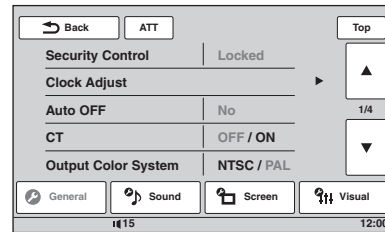

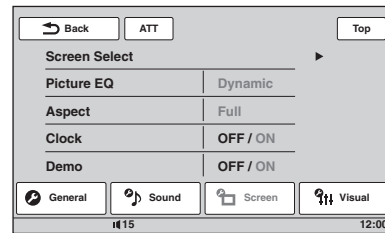

2 Touch “Screen.”

The screen setting display appears.



3 Touch “Demo” to set to “ON” or “OFF.”

The setting is complete.

To scroll the options (only when required), touch /.

To return to the previous display, touch “Back.”

General settings

Touch  → “General” → the desired item → the desired option. For details on this procedure, see “Basic setting operation” on page 51.

Follow the page reference for details. “●” indicates the default setting.

Item	Option	Purpose	Unit status
Security Control (page 59)	–	–	Any status.
Clock Adjust (page 59)	–	–	Any status.
Auto OFF Shuts off automatically after a desired time when the unit is off.	No (●)	To deactivate the Auto Off function.	Any status.
	30sec, 30min, 60min	To select the desired time.	
CT (Clock Time) (page 23, 24)	ON	To activate the CT function.	Any status.
	OFF (●)	To deactivate the CT function.	
Output Color System Changes the color system according to the connected monitor. (SECAM is not supported.)	PAL	To set to PAL.	Unit off.
	NTSC (●)	To set to NTSC.	
Dimmer Changes the display brightness.	Auto (●)	To dim the display automatically when you turn lights on. (Available only when the illumination control lead is connected.)	Any status.
	ON	To dim the display.	
Monitor Angle (page 49)	–	–	Any status.
Dimmer Level Sets the brightness level when the dimmer is activated.	(–5 ~ +5)	To select the level.	Any status.
	●: 0		
Touch Panel Adjust (page 49)	–	–	Any status.
Beep	ON (●)	To activate the operation sound.	Any status.
	OFF	To deactivate the operation sound.	
Language	English, Русский язык, Español	To select the display language.	Any status.

Item	Option	Purpose	Unit status
Key Illumination	ON (●)	To turn on the button illumination.	Any status.
	OFF	To turn off the button illumination.	
Rotary Commander Changes the operative direction of rotary commander controls.	Default (●)	To use in the factory-set position.	Any status.
	Reverse	To use on the right side of the steering column.	
AUX1 Input (page 59) Sets the type of device connected to the AUX1 IN terminals to switch the background screen accordingly.	Video (●)	To show the picture from the connected device.	Unit off.
	Audio	To show this unit's background screen.	
	OFF	To deactivate the AUX input.	
AUX2 Input* (page 59) Sets the type of device connected to the AUX2 IN/ BUS AUDIO IN terminals to switch the background screen accordingly.	Video (●)	To show the picture from the connected device.	Unit off.
	Audio	To show this unit's background screen.	
	OFF	To deactivate the AUX input.	
No Signal Shows the background screen automatically when no external video signal is detected.	Through (●)	To show the no signal screen.	Unit off.
	Blank	To show the background screen automatically.	
Camera Input (page 60) Activates the video input from the connected rear view camera.	OFF (●)	To deactivate the input.	Any status.
	ON	To show the picture from the rear view camera when the back lamp lights up (or the shift lever is set to the R (reverse) position).	
Rear View Camera Setting (page 60)	–	–	Any status.

* When a device is connected to BUS CONTROL IN, "Sony BUS Input" appears instead of "AUX2 Input," and only options "Video" and "Audio" are selectable.

Sound settings

Touch  → “Sound” → the desired item → the desired option. For details on this procedure, see “Basic setting operation” on page 51.

Follow the page reference for details. “●” indicates the default setting.

Item	Option	Purpose	Unit status
EQ7 (page 46)	OFF (●)	To cancel the equalizer curve.	During reception/ playback.
	Xplod, Vocal, Edge, Cruise, Space, Gravity, Custom	To select the equalizer curve; customize the equalizer curve.	
Balance/Fader (page 46)	Balance: (L10 ~ R10)	To adjust the level.	During reception/ playback.
	Fader: (F10 ~ R10)		
	●: 0		
Listening Position (page 47) Sets the listening position and subwoofer position.	Subwoofer: (-6 ~ +6)	To not set the listening position.	During reception/ playback.
	●: 0		
	OFF (●)		
	Front L		
	Front R		
	Front		
All	To set to the center of your car.		
Custom	Custom	To precisely calibrate the listening position (page 47).	
	Subwoofer: Near, Normal (●), Far	To select the subwoofer position. (Available only when the listening position is set to “Front L,” “Front R,” “Front” or “All.”)	
CSO (Center Speaker Organizer) (page 48) Sets the virtual center speaker mode.	OFF (●), CSO1, CSO2, CSO3	To select the mode.	During disc/USB playback.
Subwoofer Sets the subwoofer connection status.	ON (●)	To set the connection status to on.	Unit off.
	OFF	To set the connection status to off.	

Item	Option	Purpose	Unit status
RBE (Rear Bass Enhancer) (page 48) Uses rear speakers as a subwoofer.	OFF (●), RBE1, RBE2, RBE3	To select the mode.	During reception/ playback.
Crossover Filter Selects the cut-off frequency of the front/rear speakers (HPF) and subwoofer (LPF).	LPF: 50 Hz, 60 Hz, 80 Hz, 100 Hz (●), 120 Hz	To select the cut-off frequency. (Available only when "Subwoofer" is set to "ON.")	During reception/ playback.
	HPF: OFF (●)	To not cut out the frequency.	
	HPF: 50 Hz, 60 Hz, 80 Hz, 100 Hz, 120 Hz	To select the cut-off frequency.	
	Subwoofer Phase: Normal (●), Reverse	To select the subwoofer phase. (Available only when "Subwoofer" is set to "ON.")	
Speaker Level (page 48)	–	–	Unit off.

Screen settings

Touch  → "Screen" → the desired item → the desired option. For details on this procedure, see "Basic setting operation" on page 51.

Follow the page reference for details. "●" indicates the default setting.





Item	Option	Purpose	Unit status
Screen Select (page 49)	–	–	Any status.
Picture EQ (page 49)	Dynamic (●), Standard, Theater, Sepia	To select the picture quality.	During video/ image playback.
	Custom 1, Custom 2	To customize the picture quality.	
Aspect (page 50)	Full (●), Normal, Wide, Zoom	To select the screen aspect ratio.	During video playback.
Clock Shows/hides the clock display in the bottom right corner of the display.	ON (●)	To show the clock display.	Any status.
	OFF	To hide the clock display.	
Demo	ON (●)	To activate the demonstration.	Unit off.
	OFF	To deactivate the demonstration.	

DVD and other playback settings

Touch  → “Visual” → the desired item → the desired option. For details on this procedure, see “Basic setting operation” on page 51.

Follow the page reference for details. “●” indicates the default setting.

Item	Option	Purpose	Unit status
DVD Menu Language	–	To change the disc’s menu language.	Unit off.
DVD Audio Language	–	To change the soundtrack language.	Unit off.
DVD Subtitle Language	–	To change the subtitle language recorded on the disc.	Unit off.
Audio DRC Makes the sound clear when the volume is low. Only for a DVD* conforming to Audio DRC (Dynamic Range Control).	Standard (●)	To select the standard setting.	Unit off.
	Wide	To obtain the feeling of being at a live performance.	
* Excluding DVD-R/DVD-R DL/ DVD-RW in VR mode.			
Multi Ch Output Switches the method of outputting multi channel sources.	Multi (●)	To output in 4.1 channels.	Unit off.
	Stereo	To downmix to 2 channels.	
DVD Parental Control (page 26)	–	To lock/unlock a disc.	Unit off.
DVD Parental Rating (page 26)	–	To set the restriction level according to the selected area.	Unit off.
DVD Parental Area (page 26)	–	To set the restriction standard by area.	Unit off.
DVD Playlist Play (For DVD-R/DVD-R DL/ DVD-RW in VR mode only)	Original (●)	To play originally recorded titles.	Unit off.
	Playlist	To play an edited playlist.	
DVD Direct Search (page 27) Sets the search item of DVD direct search play.	Chapter (●)	To search for a chapter.	Any status.
	Title	To search for a title.	

Item	Option	Purpose	Unit status
Monitor Type Selects an aspect ratio suitable for the connected monitor. (The screen aspect ratio of this unit also changes.) Depending on the disc, "4:3 Letter Box" may be selected automatically instead of "4:3 Pan Scan," and vice versa.	16:9 (●) 	To display the wide picture. Suitable when connecting to a wide-screen monitor or a monitor with a wide mode function.	
	4:3 Letter Box 	To display a wide picture with bands on the upper and lower positions of the screen. Suitable when connecting to a 4:3 screen monitor.	Unit off.
	4:3 Pan Scan 	To display a wide picture on the entire screen and automatically cut off the portions that do not fit.	
Zappin Playing Time (page 35)	6sec, 15sec (●), 30sec	To select the playback time for the ZAPPIN function.	During audio playback.
Zappin Beep (page 35)	ON (●)	To have the beep sound between track passages.	During audio playback. 
	OFF	To deactivate the beep sound.	
Multi Disc Resume	ON (●)	To store the resume settings in memory for up to 5 video* discs. <i>* DVD VIDEO/VCD/MPEG-4 only.</i>	Unit off.
	OFF	To not store the resume settings in memory. Resume playback is available only for the current disc in the unit.	
USB Resume	ON (●)	To store resume settings in memory for MPEG-4 files in the USB device.	Unit off.
	OFF	To not store the resume settings in memory.	
JPEG Slide Show	5sec (●), 10sec, 20sec, 60sec, Fixed	To select the slide show interval.	Unit off.
Video CD PBC (page 24)	ON	To play VCD with the PBC function.	Unit off.
	OFF (●)	To play VCD without the PBC function.	

continue to next page →

Item	Option	Purpose	Unit status
Reset All Settings Resets all settings in the visual setting menu (excluding parental control setting).	Yes, No	To confirm resetting.	Unit off.

Notes

- If parental control is applied, resume playback will not work. In this case, playback starts from the beginning of the disc when it is inserted.
- Do not power off the unit while resetting, as it takes a few seconds to complete.

Setting the security code

This unit has a security function to discourage theft. Enter a 4-digit number as your security code.

Once the security function is activated, you need to enter the security code to turn on the unit after re-installing the unit in another car or charging the battery.

Activating the security function

- 1 Touch "Source List," then .
The general setting menu appears. If not, touch "General."
- 2 Touch "Security Control."
The security code setting display appears.
- 3 Touch the number keys to enter your security code, then "OK."
- 4 To confirm, touch the number keys to reenter your security code, then "OK."
The setting is complete.

To delete an entered number, touch "Clear."
To return to the previous display, touch "Back."

The 4-digit input prompt appears when you turn on the unit after re-installing in another car or charging the battery. Touch the number keys to enter your security code.

Deactivating the security function

- 1 Follow steps 1 to 2 above.
The security unlock display appears.
- 2 Touch the number keys to enter your security code.
"Unlocked" appears, and the security function is deactivated.

Setting the clock

The clock uses a 12-hour indication.

- 1 Touch "Source List," then .
The general setting menu appears. If not, touch "General."
- 2 Touch "Clock Adjust."
The setting display appears.
- 3 Touch "AM" or "PM."
- 4 Set the hour and minute.
For example, to set to 8:30, touch "0830."
- 5 Touch "OK."
The setting is complete.

To delete an entered number, touch "Clear."
To return to the previous display, touch "Back."

Using Optional Equipment

Auxiliary audio/video equipment

You can connect up to 2 optional devices, such as portable media player, game, etc., to the AUX1 IN and AUX2 IN/BUS AUDIO IN terminals on the unit.

Selecting auxiliary device

- 1 Touch "Source List," then "AUX."
The AUX playback display appears.

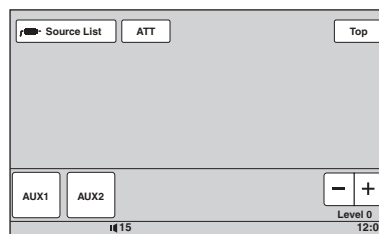

- 2 Touch "AUX1" or "AUX2" to select the device.

Operate by the portable device itself.

Adjusting the volume level

Be sure to adjust the volume for each connected device before playback.

The volume level is common to "AUX1" and "AUX2."

- 1 Reduce the volume on the unit.
- 2 Touch "Source List," then "AUX."
The AUX playback display appears.
- 3 Start playback of the portable device at a moderate volume.
- 4 Set your usual listening volume on the unit.
- 5 Touch -/+ in the "Level" box repeatedly to adjust the level.
The level is adjustable in single steps, between -8 and +18.

continue to next page →

Setting the type of device

By setting the type (video or audio) of each connected device, the background screen can be switched accordingly.

- 1 While the unit is off, touch **“Source List,”** then .
The general setting menu appears. If not, touch **“General.”**
- 2 Touch **▲/▼** to scroll, then **“AUX1 Input”** or **“AUX2 Input.”**
- 3 Touch **“Audio”** or **“Video.”**
The setting is complete.

To deactivate the AUX input, select **“OFF.”**
To return to the previous display, touch **“Back.”**

Rear view camera

By connecting the optional rear view camera to the CAMERA IN terminal, you can display the picture from the rear view camera.

Displaying the picture

To display the picture from a rear view camera, you need to activate the input.

- 1 Touch **“Source List,”** then .
The general setting menu appears. If not, touch **“General.”**
- 2 Touch **▲/▼** to scroll, then **“Camera Input”** to set to **“ON.”**
The setting is complete.

The picture from rear view camera appears when the back lamp lights up (or the shift lever is set to the R (reverse) position).

Notes

- When backing up your car, watch the surroundings carefully for safety. Do not depend on the rear view camera exclusively.
- The picture from a rear view camera does not appear in the rear monitor.

Rear view camera settings

You can display setting items on the picture from the rear view camera to assist operation.

- 1 Touch **“Source List,”** then .
The general setting menu appears. If not, touch **“General.”**
- 2 Touch **▲/▼** to scroll, then **“Rear View Camera Setting.”**
The setting items appear.

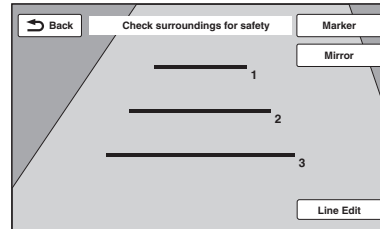

Displaying marker lines

Touch **“Marker.”**
Touch **“Marker”** again to hide the marker lines.





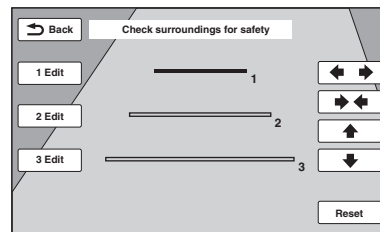

Reversing the picture

Touch **“Mirror.”**
A mirror reversed picture appears.

Editing lines

- 1 Touch **“Line Edit.”**



- 2 Select the line to edit.
Touch **“1 Edit,”** **“2 Edit”** or **“3 Edit”** corresponding to the line to edit.
 - 3 Edit the line.
To increase the length, touch  .
To reduce the length, touch  .
To adjust the position, touch  or .
To restore the default setting, touch **“Reset.”**
- To return to the previous display, touch **“Back.”**

Additional Information

Precautions

- Cool off the unit beforehand if your car has been parked in direct sunlight.
- Power antenna (aerial) extends automatically.

Moisture condensation

Should moisture condensation occur inside the unit, remove the disc and wait for about an hour for it to dry out; otherwise the unit will not operate properly.

To maintain high sound quality

Do not splash liquid onto the unit or discs.

Notes on LCD panel

- Do not press on the LCD panel as doing so can distort the picture or cause a malfunction (i.e., the picture may become unclear, or the LCD panel may be damaged).
- Do not touch other than with the finger, as it may damage or break the LCD panel.
- Clean the LCD panel with a dry soft cloth. Do not use solvents such as benzine, thinner, commercially available cleaners, or antistatic spray.
- Do not use this unit outside the temperature range 5 – 45 °C (41 – 113 °F).
- If your car was parked in a cold or hot place, the picture may not be clear. However, the monitor is not damaged, and the picture will become clear after the temperature in your car becomes normal.
- Some stationary blue, red or green dots may appear on the monitor. These are called “bright spots,” and can happen with any LCD. The LCD panel is precision-manufactured with more than 99.99 % of its segments functional. However, it is possible that a small percentage (typically 0.01 %) of the segments may not light up properly. This will not, however, interfere with your viewing.

Notes on discs

- Do not expose discs to direct sunlight or heat sources such as hot air ducts, nor leave it in a car parked in direct sunlight.
- Before playing, wipe the discs with a cleaning cloth from the center out. Do not use solvents such as benzine, thinner, commercially available cleaners.



- This unit is designed to play back discs that conform to the Compact Disc (CD) standard. DualDiscs and some of the music discs encoded with copyright protection technologies do not conform to the Compact Disc (CD) standard, therefore, these discs may not be playable by this unit.
- **Discs that this unit CANNOT play**
 - Discs with labels, stickers, or sticky tape or paper attached. Doing so may cause a malfunction, or may ruin the disc.
 - Discs with non-standard shapes (e.g., heart, square, star). Attempting to do so may damage the unit.
 - 8 cm (3 1/4 in) discs.

Note on playback operations of DVDs and VCDs

Some playback operations of DVDs and VCDs may be intentionally set by software producers. Since this unit plays DVDs and VCDs according to the disc contents the software producers designed, some playback features may not be available. Also, refer to the instructions supplied with the DVDs or VCDs.

Notes on DATA CDs and DATA DVDs

- Some DATA CDs/DATA DVDs (depending on the equipment used for its recording, or the disc condition) may not play on this unit.
- Finalization is required for some discs (page 62).
- The unit is compatible with the following standards.
 - For DATA CDs
 - ISO 9660 level 1/level 2 format, Joliet/Romeo in the expansion format
 - Multi Session
 - For DATA DVDs
 - UDF Bridge format (combined UDF and ISO 9660)
 - Multi Border
- The maximum number of:
 - folders (albums): 256 (including root and empty folders).
 - files (tracks/images/videos) and folders contained in a disc: 2,000 (if a folder/file names contain many characters, this number may become less than 2,000).
 - displayable characters for a folder/file name: 64 (Joliet/Romeo).

continue to next page →

Notes on finalizing discs

The following discs are required to be finalized to play on this unit.

- DVD-R/DVD-R DL (in video mode/VR mode)
- DVD-RW in video mode
- DVD+R/DVD+R DL
- CD-R
- CD-RW

The following discs can be played without finalization.

- DVD+RW – automatically finalized.
- DVD-RW in VR mode – finalization not required.

For details, see the manual supplied with the disc.

Notes on Multi Session CDs/Multi Border DVDs

This unit can play Multi Session CDs/Multi Border DVDs under the following conditions. Note that the session must be closed and the disc must be finalized.

- When CD-DA (Compact Disc Digital Audio) is recorded in the first session:
The unit recognizes the disc as CD-DA and only CD-DA of the first session is played, even if an other format (e.g., MP3) is recorded in other sessions.
- When CD-DA is recorded other than in the first session:
The unit recognizes the disc as a DATA CD or DATA DVD, and all CD-DA sessions are skipped.
- When an MP3/WMA/AAC/JPEG/MPEG-4 is recorded:
Only the sessions containing the selected file type (audio/video/image)* are played (if CD-DA or other data exists in other sessions, they are skipped).

* For details on how to select the file type, see page 34.

Playback order of MP3/WMA/AAC/JPEG/MPEG-4 files

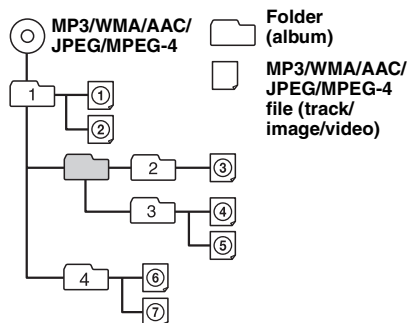

About MP3 files

- MP3, which stands for MPEG-1 Audio Layer-3, is a music file compression format standard. It compresses audio CD data to approximately 1/10 of its original size.
- ID3 tag versions 1.0, 1.1, 2.2, 2.3 and 2.4 apply to MP3 only. ID3 tag is 15/30 characters (1.0 and 1.1), or 63/126 characters (2.2, 2.3 and 2.4).
- When naming an MP3 file, be sure to add the file extension “.mp3” to the file name.
- During playback or fast-forward/reverse of a VBR (Variable Bit Rate) MP3 file, elapsed playback time may not display accurately.

Note on MP3

If you play a high-bit-rate MP3, such as 192 kbps, sound may be intermittent.

About WMA files

- WMA, which stands for Windows Media Audio, is a music file compression format standard. It compresses audio CD data to approximately 1/22* of its original size.
- WMA tag is 63 characters.
- When naming a WMA file, be sure to add the file extension “.wma” to the file name.
- During playback or fast-forward/reverse of a VBR (Variable Bit Rate) WMA file, elapsed playback time may not display accurately.

* only for 64 kbps

Note on WMA

Playback of the following WMA files is not supported.

- lossless compression
- copyright-protected

About AAC files

- AAC tag is 126 characters.
- When naming an AAC file, be sure to add the file extension “.m4a” to the file name.

About JPEG files

- JPEG, which stands for Joint Photographic Experts Group, is an image file compression format standard. It compresses still images approximately 1/10 to 1/100 of original size.
- When naming a JPEG file, be sure to add the file extension “.jpg” to the file name.

Note on JPEG

Playback of progressive JPEG files is not supported.

About MPEG-4 files

MPEG-4 files meeting the following requirements can be played. Playback is not guaranteed for all MPEG-4 files meeting the requirements.

- Profile: MPEG-4 Simple profile
- Bit rate: Max. 7 Mbps on USB FS, 10 Mbps on DVD, 7 Mbps on CD
- Frame rate: Max. 30 fps
- Image size: Max. 720 × 480 pixels
- Audio: Max. 320 kbps (AAC-LC)
- File extension: .mp4

About iPod

- You can connect to the following iPod models. Update your iPod devices to the latest software before use.

Made for

- iPod touch
- iPod touch (2nd generation)
- iPod classic
- iPod classic (120GB)
- iPod with video*
- iPod nano (4th generation)
- iPod nano (3rd generation)
- iPod nano (2nd generation)
- iPod nano (1st generation)*

Works with

- iPhone
- iPhone 3G
- iPhone 3GS

* *Passenger control is not available for iPod nano (1st generation) or iPod with video.*

- “Made for iPod” means that an electronic accessory has been designed to connect specifically to iPod and has been certified by the developer to meet Apple performance standards.
- “Works with iPhone” means that an electronic accessory has been designed to connect specifically to iPhone and has been certified by the developer to meet Apple performance standards.
- Apple is not responsible for the operation of this device or its compliance with safety and regulatory standards.

About Bluetooth function

What is Bluetooth technology?

- Bluetooth wireless technology is a short-range wireless technology that enables wireless data communication between digital devices, such as a cellular phone and a headset. Bluetooth wireless technology operates within a range of about 10 m (about 33 feet). Connecting two devices is common, but some devices can be connected to multiple devices at the same time.
- You do not need to use a cable for connection since Bluetooth technology is a wireless technology, neither is it necessary for the devices to face one another, such is the case with infrared technology. For example, you can use such a device in a bag or pocket.
- Bluetooth technology is an international standard supported by millions of companies all over the world, and employed by various companies worldwide.

On Bluetooth communication

- Bluetooth wireless technology operates within a range of about 10 m. Maximum communication range may vary depending on obstacles (person, metal, wall, etc.) or electromagnetic environment.
- The following conditions may affect the sensitivity of Bluetooth communication.
 - There is an obstacle such as a person, metal, or wall between this unit and Bluetooth device.
 - A device using 2.4 GHz frequency, such as a wireless LAN device, cordless telephone, or microwave oven, is in use near this unit.
- Because Bluetooth devices and wireless LAN (IEEE802.11b/g) use the same frequency, microwave interference may occur and result in communication speed deterioration, noise, or invalid connection if this unit is used near a wireless LAN device. In such as case, perform the following.
 - Use this unit at least 10 m away from the wireless LAN device.
 - If this unit is used within 10 m of a wireless LAN device, turn off the wireless LAN device.
 - Install this unit and Bluetooth device as near to each other as possible.
- Microwaves emitting from a Bluetooth device may affect the operation of electronic medical devices. Turn off this unit and other Bluetooth devices in the following locations, as it may cause an accident.
 - where inflammable gas is present, in a hospital, train, airplane, or petrol station
 - near automatic doors or a fire alarm
- This unit supports security capabilities that comply with the Bluetooth standard to provide a secure connection when the Bluetooth wireless technology is used, but security may not be enough depending on the setting. Be careful when communicating using Bluetooth wireless technology.

continue to next page → **63**

- We do not take any responsibility for the leakage of information during Bluetooth communication.
- Connection with all Bluetooth devices cannot be guaranteed.
 - A device featuring Bluetooth function is required to conform to the Bluetooth standard specified by Bluetooth SIG, and be authenticated.
 - Even if the connected device conforms to the above mentioned Bluetooth standard, some devices may not be connected or work correctly, depending on the features or specifications of the device.
 - While talking on the phone handsfree, noise may occur, depending on the device or communication environment.
- Depending on the device to be connected, it may require some time to start communication.

Others

- Using the Bluetooth device may not function on cellular phones, depending on radio wave conditions and location where the equipment is being used.
- If you experience discomfort after using the Bluetooth device, stop using the Bluetooth device immediately. Should any problem persist, consult your nearest Sony dealer.

If you have any questions or problems concerning your unit that are not covered in this manual, consult your nearest Sony dealer.

Maintenance

Replacing the lithium battery of the card remote commander

Under normal conditions, the battery will last approximately 1 year. (The service life may be shorter, depending on the conditions of use.) When the battery becomes weak, the range of the card remote commander becomes shorter. Replace the battery with a new CR2025 lithium battery. Use of any other battery may present a risk of fire or explosion.

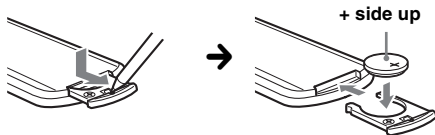

Notes on the lithium battery

- Keep the lithium battery out of the reach of children. Should the battery be swallowed, immediately consult a doctor.
- Wipe the battery with a dry cloth to assure a good contact.
- Be sure to observe the correct polarity when installing the battery.
- Do not hold the battery with metallic tweezers, otherwise a short-circuit may occur.

WARNING

Battery may explode if mistreated.
Do not recharge, disassemble, or dispose of in fire.

Fuse replacement

When replacing the fuse, be sure to use one matching the amperage rating stated on the original fuse. If the fuse blows, check the power connection and replace the fuse. If the fuse blows again after replacement, there may be an internal malfunction. In such a case, consult your nearest Sony dealer.

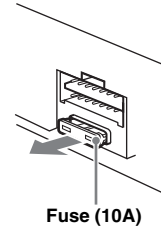

Removing the unit

- 1 Insert both release keys simultaneously until they click.

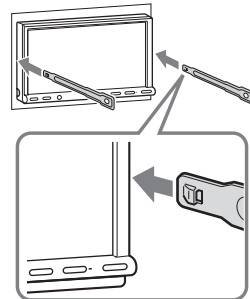

- 2 Pull the release keys to unseat the unit.

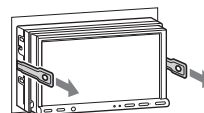

- 3 Slide the unit out of the mounting.

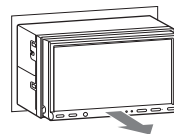

Specifications

AUDIO POWER SPECIFICATIONS



CEA2006 Standard
Power Output: 17 Watts RMS \times 4 at
4 Ohms < 1% THD+N
SN Ratio: 82 dBA
(reference: 1 Watt into 4 Ohms)

Monitor section

Display type: Wide LCD color monitor
Dimensions: 7.0 in
System: TFT active matrix
Number of pixels: 1,152,000 pixels
Color system:
PAL/NTSC/SECAM/PAL-M automatic select

Tuner section

FM

Tuning range: 87.5 – 107.9 MHz
Antenna (aerial) terminal:
External antenna (aerial) connector
Intermediate frequency: 150 kHz
Usable sensitivity: 10 dBf
Selectivity: 75 dB at 400 kHz
Signal-to-noise ratio: 70 dB (mono)
Separation: 40 dB at 1 kHz
Frequency response: 20 – 15,000 Hz

AM

Tuning range: 530 – 1,710 kHz
Antenna (aerial) terminal:
External antenna (aerial) connector
Intermediate frequency: 25 kHz
Sensitivity: 26 μ V

DVD/CD Player section

Signal-to-noise ratio: 120 dB
Frequency response: 10 – 20,000 Hz
Wow and flutter: Below measurable limit
Harmonic distortion: 0.01 %
Region code: Labeled on the bottom of the unit

USB Player section

Interface: USB (Full-speed)
Maximum current: 500 mA

Wireless Communication

Communication System:
Bluetooth Standard version 2.0 + EDR
Output:
Bluetooth Standard Power Class 2 (Max. +4 dBm)
Maximum communication range:
Line of sight approx. 10 m (33 ft)*1
Frequency band:
2.4 GHz band (2.4000 – 2.4835 GHz)
Modulation method: FHSS
Compatible Bluetooth Profiles*2:
A2DP (Advanced Audio Distribution Profile)
AVRCP (Audio Video Remote Control Profile) 1.3
HFP (Handsfree Profile) 1.5
PBAP (Phone Book Access Profile)
OPP (Object Push Profile)

- *1 The actual range will vary depending on factors such as obstacles between devices, magnetic fields around a microwave oven, static electricity, reception sensitivity, antenna's performance, operating system, software application, etc.
*2 Bluetooth standard profiles indicate the purpose of Bluetooth communication between devices.

Power amplifier section

Outputs: Speaker outputs
Speaker impedance: 4 – 8 ohms
Maximum power output: 52 W \times 4 (at 4 ohms)

General

Outputs:

Video output terminal (rear)
Audio output terminals (front/rear)
Subwoofer output terminal
Power antenna (aerial) relay control terminal
Power amplifier control terminal

Inputs:

Telephone ATT control terminal
Illumination control terminal
BUS audio input terminals
BUS control input terminal
Remote controller input terminal
Antenna (aerial) input terminal
Parking break control terminal
Microphone input terminal
Reverse input terminal
Camera input terminal
AUX audio input terminals
AUX video input terminals
USB signal input connector

Power requirements: 12 V DC car battery
(negative ground (earth))

Dimensions: Approx. 178 \times 100 \times 189 mm
(7 ¹/₈ \times 4 \times 7 ¹/₂ in) (w/h/d)

Mounting dimensions: Approx. 182 \times 111 \times 164 mm
(7 ¹/₄ \times 4 ³/₈ \times 6 ¹/₂ in) (w/h/d)

Mass: Approx. 2.5 kg (5 lb 9 oz)

Supplied accessories:

Card remote commander: RM-X170
Parts for installation and connections (1 set)
Extension cord for AUX audio/video input terminals
Microphone: XA-MC10
CD-ROM (Application disc)

Optional accessories/equipment:

BUS cable (supplied with an RCA pin cord):
RC-61 (1 m), RC-62 (2 m)
Source selector: XA-C40
AUX-IN selector: XA-300
USB connection cable for iPod: RC-200IPV
HD Radio™ tuner: XT-100HD
Rear View Camera: XA-R800C

Your dealer may not handle some of the above listed accessories. Please ask the dealer for detailed information.

continue to next page →

US and foreign patents licensed from Dolby Laboratories.

MPEG Layer-3 audio coding technology and patents licensed from Fraunhofer IIS and Thomson.

This product is protected by certain intellectual property rights of Microsoft Corporation. Use or distribution of such technology outside of this product is prohibited without a license from Microsoft or an authorized Microsoft subsidiary.

Design and specifications are subject to change without notice.

- Halogenated flame retardants are not used in the certain printed wiring boards.
- Halogenated flame retardants are not used in cabinets.
- Packaging cushions are made from paper.

Region code

The region system is used to protect software copyrights.

The region code is located on the bottom of the unit, and only DVDs labeled with an identical region code can be played on this unit.

DVDs labeled  can also be played.

If you try to play any other DVD, the message "Playback prohibited by region code." will appear on the monitor screen. Depending on the DVD, no region code may be labeled even though playing the DVD is prohibited by area restrictions.

System requirements for the software in the supplied CD-ROM

Computer

- IBM PC/AT compatible machines
- CPU: Pentium III Processor 800 MHz or higher
- Hard Disc space: 300 MB or more (500 MB or more recommended)
- Memory: 128 MB or more (256 MB or more recommended)
- CD-ROM drive
- USB port

OS

- Windows® XP Home Edition/Professional with Service Pack 3 (or later)
- Windows® XP Media Center Edition/Media Center Edition 2004/Media Center Edition 2005
- Windows Vista® Home Basic/Home Premium/Business/Ultimate with Service Pack 1 (or later)

Monitor

High color (16-bit) or more, 800 × 600 dots or more

Other

Internet connection

Notes

- The following system environments are not supported.
 - Non IBM PC type computers, such as Macintosh, etc.
 - Homemade computers
 - OS upgraded computers
 - Multi-display environment
 - Multi-boot environment
 - Virtual machine environment
- Depending on the computer condition, operation may not be possible even with the recommended environment.

Troubleshooting

The following checklist will help you remedy problems you may encounter with your unit. Before going through the checklist below, check the connection and operating procedures.

If the problem is not solved, visit the following support site.

Support site

<http://esupport.sony.com>
<http://www.xplodsony.com/>

General

No power is being supplied to the unit.

- Check the connection or fuse.
- If the unit is turned off and the display disappears, it cannot be operated with the remote commander.
 - Turn on the unit.

The power antenna (aerial) does not extend.

The power antenna (aerial) does not have a relay box.

No beep sound.

- The beep sound is canceled (page 52).
- An optional power amplifier is connected and you are not using the built-in amplifier.

The contents of the memory have been erased.

- The reset button has been pressed.
 - Store again into the memory.
- The power supply lead or battery has been disconnected or it is not connected properly.

Stored stations and correct time are erased.

The fuse has blown.

Makes noise when the position of the ignition is switched.

The leads are not matched correctly with the car's accessory power connector.

The display disappears from/does not appear on the monitor.

- The dimmer is set to "ON" (page 52).
- The display disappears if you press and hold **(SOURCE/OFF)**.
 - Press **(SOURCE/OFF)** on the unit until the display appears.
- "M.OFF" is touched and the Monitor Off function is activated (page 13).
 - Touch anywhere on the display to turn back on.

The display does not respond to your touch correctly.

- Touch one part of the display at a time. If two or more parts are touched simultaneously, the display will not operate correctly.
- Adjust the touch point of the display (page 49).

The Auto Off function does not operate.

The unit is turned on. The Auto Off function activates after turning off the unit.

- Turn off the unit.

Card remote commander operation is not possible.

If the Monitor Off function is activated (no lighting), card remote commander operation is not possible (page 13).

The menu items cannot be selected.

Unavailable menu items are shown in grey.

AUX cannot be selected as the source.

All AUX input settings are set to "OFF".

- Set "AUX1 Input"/"AUX2 Input" to "Video" or "Audio" (page 60).

Radio reception**The stations cannot be received.****The sound is hampered by noises.**

- The connection is not correct.
 - Connect a power antenna (aerial) control lead (blue) or accessory power supply lead (red) to the power supply lead of a car's antenna (aerial) booster (only when your car has built-in FM/AM antenna (aerial) in the rear/side glass).
 - Check the connection of the car antenna (aerial).
 - If the auto antenna (aerial) will not go up, check the connection of the power antenna (aerial) control lead.

Preset tuning is not possible.

- Store the correct frequency in the memory.
- The broadcast signal is too weak.

Automatic tuning is not possible.

- Setting of the local seek mode is not correct.
 - Tuning stops too frequently:
 - Set "Local" to "ON" (page 18).
 - Tuning does not stop at a station:
 - Set "Mono" to "ON" (page 18).
- The broadcast signal is too weak.
 - Perform manual tuning.

During FM reception, the "Stereo" indication flashes.

- Tune in the frequency accurately.
- The broadcast signal is too weak.
 - Set "Mono" to "ON" (page 18).

An FM program broadcast in stereo is heard in monaural.

The unit is in monaural reception mode.

- Set "Mono" to "OFF" (page 18).

RDS**PTY displays "None."**

- The current station is not an RDS station.
- RDS data has not been received.
- The station does not specify the program type.

Picture**There is no picture/picture noise occurs.**

- A connection has not been made correctly.
- Check the connection to the connected equipment, and set the input selector of the equipment to the source corresponding to this unit.
- Defective or dirty disc.
- Installation is not correct.
 - Install the unit at an angle of less than 45° in a sturdy part of the car.
- The parking cord (light green) is not connected to the parking brake switch cord, or the parking brake is not applied.

Picture does not fit in the screen.

The aspect ratio is fixed on the DVD.

There is no picture/picture noise occurs in the rear monitor.

- The source/mode which is not connected is selected.
 - If there is no input, no picture appears in the rear monitor.
- The color system setting is incorrect.
 - Set the color system to "PAL" or "NTSC" according to the connected monitor (page 52).
- The picture of the rear view camera is displayed on this unit.
 - No picture appears in the rear monitor if the picture of the rear view camera is displayed on this unit.

continue to next page →

Sound

There is no sound/sound skips/sound cracks.

- A connection has not been made correctly.
- Check the connection to the connected equipment, and set the input selector of the equipment to the source corresponding to this unit.
- Defective or dirty disc.
- Installation is not correct.
 - Install the unit at an angle of less than 45° in a sturdy part of the car.
- The MP3 file sampling rate is not 32, 44.1 or 48 kHz.
- The WMA file sampling rate is not 32, 44.1 or 48 kHz.
- The AAC file sampling rate is not 44.1 or 48 kHz.
- The MP3 file bit rate is not 48 to 192 kbps.
- The WMA file bit rate is not 64 to 192 kbps.
- The AAC file bit rate is not 40 to 320 kbps.
- The unit is in pause/reverse/fast-forward mode.
- The settings for the outputs are not made correctly.
- The DVD output level is too low (page 25).
- The volume is too low.
- The ATT function is activated, or the Telephone ATT function (when the interface cable of a car telephone is connected to the ATT lead) is activated.
- The position of the fader control "Fader" is not set for a 2-speaker system.
- Unsupported format (such as DTS).
 - Check if the format is supported by this unit (page 11).

Sound is noisy.

Keep cords and cables away from each other.

Disc operation

The disc cannot be loaded.

- Another disc is already loaded.
- The disc has been forcibly inserted upside down or in the wrong way.

The disc does not play back.

- Defective or dirty disc.
- The disc is not applicable.
- The DVD is not applicable due to the region code.
- The disc is not finalized (page 62).
- The disc format and file version are incompatible with this unit (page 11, 61).
- Press **▲** to remove the disc.

MP3/WMA/AAC/JPEG/MPEG-4 files do not play back.

- Recording was not performed according to the ISO 9660 level 1 or level 2, the Joliet or Romeo in the expansion format (DATA CD), or the UDF Bridge format (DATA DVD) (page 61).
- The file extension is incorrect (page 62).
- Files are not stored in MP3/WMA/AAC/JPEG/MPEG-4 format.
- If the disc contains multiple file types, only the selected file type (audio/video/image) can be played.
 - Select the appropriate file type using the list (page 34).

MP3/WMA/AAC/JPEG/MPEG-4 files take longer to play back than others.

The following discs take a longer time to start playback.

- a disc recorded with a complicated tree structure.
- a disc recorded in Multi Session/Multi Border.
- a disc to which data can be added.

The disc does not start playing from the beginning.

Resume playback or multi-disc resume playback (page 57) has taken effect.

Certain functions cannot be performed.

Depending on the disc, you may not be able to perform operations such as stop, search, or repeat/shuffle play. For details, see the manual supplied with the disc.

The soundtrack/subtitle language or angle cannot be changed.

- Use the DVD menu instead of the direct selection button on the card remote commander (page 19).
- Multilingual tracks, multilingual subtitles, or multi-angles are not recorded on the DVD.
- The DVD prohibits changing.

The operation buttons do not function.

The disc will not eject.

Press the reset button (page 16).

You forgot the password for parental control.

Enter "5776" in the password input display to unlock (page 26).

USB playback

Cannot play back items via a USB hub.

This unit cannot recognize USB devices via a USB hub.

Cannot play back items.

Reconnect the USB device.

The USB device takes longer to play back.

The USB device contains large-sized files or files with a complicated tree structure.

A beep sounds.

During playback, the USB device has been disconnected.

→ Before disconnecting a USB device, make sure to stop playback first for data protection.

The sound is intermittent.

The sound may be intermittent at a high-bit-rate of more than 320 kbps.

Bluetooth function

The other Bluetooth device cannot detect this unit.

- Set "Signal" to "ON" (page 45).
- Set "Discoverable" to "Show" (page 45).
- While connecting to the other Bluetooth device, this unit cannot be detected from another device. Disconnect the current connection and search for this unit from another device. The disconnected device can be reconnected by selecting from the list of registered devices.

This unit cannot detect the other Bluetooth device.

Check the Bluetooth setting of the other device.

Connection is not possible.

- Depending on the other device, searching from this unit may not be possible.
 - Search for this unit from the other device.
- Depending on the status of the other device, searching from this unit may not be possible.
 - Search for this unit from the other device.
- Check the pairing and connection procedures in the manual of the other device, etc., and perform the operation again.

The name of the detected device does not appear.

Depending on the status of the other device, it may not be possible to obtain the name.

No ring tone.

- Raise the volume while receiving a call.
- Depending on the connecting device, the ring tone may not be sent properly.
 - Set "Ringtone" to "Default" (page 45).

The talker's voice volume is low.

Raise the volume during a call.

The other party says that the volume is too low or high.

Adjust the "MIC Gain" level (page 41).

Echo or noise occurs in phone call conversations.

- Reduce the volume.
- "EC/NC Mode" is set to "OFF".
 - Set "EC/NC Mode" to "Mode 1" or "Mode 2" (page 45).
- If ambient noise other than the phone call sound is loud, try reducing this noise.

E.g.: If a window is open and road noise, etc., is loud, shut the window. If the air conditioner is loud, lower the air conditioner.

The phone sound quality is poor.

Phone sound quality depends on reception conditions of cellular phone.

→ Move your car to a place where you can enhance the cellular phone's signal if the reception is poor.

The volume of the connected Bluetooth device is low or high.

Volume level will differ depending on the Bluetooth device.

→ Reduce the volume level differences between this unit and the Bluetooth device (page 45).

No sound is output during audio streaming.

The connected Bluetooth device is paused.

→ Cancel pause of the Bluetooth device.

The sound skips during audio streaming.

- Reduce the distance between the unit and the Bluetooth device.
- If the Bluetooth device is stored in a case which interrupts the signal, remove the case while using.
- Several Bluetooth devices or other devices which emit radio waves are used nearby.
 - Turn off the other devices.
 - Increase the distance from the other devices.
- The playback sound stops momentarily when this unit is connecting to a cellular phone. This is not a malfunction.

You cannot control the connected Bluetooth device during audio streaming.

Check that the connected Bluetooth device supports AVRCP.

Some functions do not work.

Check that the connecting device supports the functions in question.

The name of the other party does not appear when a call is received.

- The other party is not stored in the phonebook.
 - Store in the phonebook (page 41).
- The calling phone is not set to send the phone number.

A call is answered unintentionally.

- The connecting phone is set to start a call automatically.
- "Auto Answer" of this unit is set to "Short" or "Long" (page 45).

Pairing failed due to time out.

Depending on the connecting device, the time limit for pairing may be short. Try completing the pairing within the time by setting a single digit passkey.

Bluetooth function cannot be operated.

Turn off the unit by pressing **(SOURCE/OFF)** for 1 second, then turn on the unit.

No sound is output from the car speakers during handsfree call.

If the sound is output from the cellular phone, set the cellular phone to output the sound from the car speakers.

Error displays/messages

Bluetooth device is not found.

The unit cannot detect a connectable Bluetooth device.
→ Check the Bluetooth setting of the connecting device.

Busy now... Please try again.

The unit is busy.
→ Wait for a moment and try again.

Cannot play this disc. Check disc condition.

- The disc is incompatible with this unit.
- The disc is not finalized.

Cannot read.

- The unit cannot read the data due to some problem.
- The data is damaged or corrupted.

Connection Error to Phonebook

Phonebook access is disconnected by the cellular phone.

→ Access the phonebook again.

Download Error

Phonebook download of the cellular phone failed due to a problem.

→ Download the phonebook again (page 41).

Entry Error

Phonebook browsing of the cellular phone failed due to a problem.

→ Retry browsing (page 42).

Error

- The disc is dirty or inserted upside down.
→ Clean or insert the disc correctly.
- A blank disc has been inserted.
- The disc cannot play due to a problem.
→ Insert another disc.
- The disc is not compatible with this unit.
→ Insert a compatible disc.
- USB device was not automatically recognized.
→ Reconnect it again.
- Press **▲** to remove the disc.
- Phonebook content is changed during cellular phone access.
→ Access the phonebook again.

Error - Please select 'initialize' from the Bluetooth settings menu

A memory error has occurred.

→ Initialize the Bluetooth setting (page 45).

Handsfree device is not available

A cellular phone is not connected.

→ Connect a cellular phone (page 38).

Hubs not supported

USB hub is not supported on this unit.

Listing Error

Phonebook listing of the cellular phone failed due to a problem.

→ Retry listing (page 42).

Local Seek Up/Down

The local seek mode is on during automatic tuning.

No device found.

No device is in the list of registered Bluetooth device.

→ Perform pairing with a Bluetooth device (page 37).

No playable data

The disc does not contain playable data.

Offset

There may be an internal malfunction.

→ Check the connection. If the error indication remains on in the display, consult your nearest Sony dealer.

Output connection failure.

(Illuminates until any button is pressed.)

The connection of speakers/amplifiers is incorrect.

→ See the supplied installation/connections manual to check the connection.

Output connection failure.

(Illuminates for about 1 second.)

When the SAT tuner is connected, storing an SAT radio channel into a preset failed.

→ Be sure to receive the channel that you want to store, then try it again.

Overcurrent Caution on USB

The USB device is overloaded.

→ Disconnect the USB device, then change the source by pressing **(SOURCE/OFF)**.

→ Indicates that the USB device is out of order, or an unsupported device is connected.

Playback prohibited by region code.

The DVD playback is prohibited due to the different region code.

Please push reset.

This unit or USB device cannot be operated due to a problem.

→ Press the reset button (page 16).

Reading

The unit is reading all file/album (folder) information on the disc.

→ Wait until reading is complete and playback starts automatically. Depending on the disc structure, it may take more than a minute.

The connected USB device is not supported.

For details on the compatibility of your USB device, visit the support site.

USB device is not connected.

USB is selected as source without a USB device connected. A USB device or a USB cable has been disconnected during playback.

→ Be sure to connect a USB device and USB cable.

“L L L L” or “r r r r”

During reverse or fast-forward, you have reached the beginning or the end of the disc and you cannot go any further.

“_”

The character cannot be displayed with the unit.

If these solutions do not help improve the situation, consult your nearest Sony dealer.

If you take the unit to be repaired because of disc playback trouble, bring the disc that was used at the time the problem began.

Language code/area code list

Language code list

The language spellings conform to the ISO 639: 1988 (E/F) standard.

Code	Language	Code	Language	Code	Language	Code	Language
1027	Afar	1183	Irish	1347	Maori	1507	Samoan
1028	Abkhazian	1186	Scots Gaelic	1349	Macedonian	1508	Shona
1032	Afrikaans	1194	Galician	1350	Malayalam	1509	Somali
1039	Amharic	1196	Guarani	1352	Mongolian	1511	Albanian
1044	Arabic	1203	Gujarati	1353	Moldavian	1512	Serbian
1045	Assamese	1209	Hausa	1356	Marathi	1513	Siswati
1051	Aymara	1217	Hindi	1357	Malay	1514	Sesotho
1052	Azerbaijani	1226	Croatian	1358	Maltese	1515	Sundanese
1053	Bashkir	1229	Hungarian	1363	Burmese	1516	Swedish
1057	Byelorussian	1233	Armenian	1365	Nauru	1517	Swahili
1059	Bulgarian	1235	Interlingua	1369	Nepali	1521	Tamil
1060	Bihari	1239	Interlingue	1376	Dutch	1525	Telugu
1061	Bislama	1245	Inupiak	1379	Norwegian	1527	Tajik
1066	Bengali; Bangla	1248	Indonesian	1393	Occitan	1528	Thai
1067	Tibetan	1253	Icelandic	1403	(Afan)Oromo	1529	Tigrinya
1070	Breton	1254	Italian	1408	Oriya	1531	Turkmen
1079	Catalan	1257	Hebrew	1417	Punjabi	1532	Tagalog
1093	Corsican	1261	Japanese	1428	Polish	1534	Setswana
1097	Czech	1269	Yiddish	1435	Pashto; Pusho	1535	Tonga
1103	Welsh	1283	Javanese	1436	Portuguese	1538	Turkish
1105	Danish	1287	Georgian	1437	Portuguese	1539	Tsonga
1109	German	1297	Kazakh	1463	Quechua	1540	Tatar
1130	Bhutani	1298	Greenlandic	1481	Rhaeto- Romance	1543	Twi
1142	Greek	1299	Cambodian	1482	Kirundi	1557	Ukrainian
1144	English	1300	Kannada	1483	Romanian	1564	Urdu
1145	Esperanto	1301	Korean	1489	Russian	1572	Uzbek
1149	Spanish	1305	Kashmiri	1491	Kinyarwanda	1581	Vietnamese
1150	Estonian	1307	Kurdish	1495	Sanskrit	1587	Volapük
1151	Basque	1311	Kirghiz	1498	Sindhi	1613	Wolof
1157	Persian	1313	Latin	1499	Sangho	1632	Xhosa
1165	Finnish	1326	Lingala	1501	Serbo- Croatian	1665	Yoruba
1166	Fiji	1327	Laothian	1502	Singhalese	1684	Chinese
1171	Faroese	1332	Lithuanian	1503	Slovak	1697	Zulu
1174	French	1334	Latvian; Lettish	1505	Slovenian	1703	Not specified
1181	Frisian	1345	Malagasy	1506			

Area code list

Code	Area	Code	Area	Code	Area	Code	Area
2044	Argentina	2165	Finland	2362	Mexico	2149	Spain
2047	Australia	2174	France	2376	Netherlands	2499	Sweden
2046	Austria	2109	Germany	2390	New Zealand	2086	Switzerland
2057	Belgium	2248	India	2379	Norway	2528	Thailand
2070	Brazil	2238	Indonesia	2427	Pakistan	2184	United Kingdom
2079	Canada	2254	Italy	2424	Philippines		
2090	Chile	2276	Japan	2436	Portugal		
2092	China	2304	Korea	2489	Russia		
2115	Denmark	2363	Malaysia	2501	Singapore		

Index

A

AAC 11, 62
 Angle (Angle) 21
 Area code 71
 Audio channel (Stereo) 25
 Audio DRC (Audio DRC) 56
 Audio format (Audio) 25
 Audio streaming 44
 Auto Off (Auto OFF) 52
 Automatic answer
 (Auto Answer) 45
 Auxiliary equipment 59
 Auxiliary level (Level) 59
 Auxiliary settings (AUX1
 Input, AUX2 Input) 53, 60

B

Background screen
 (Screen Select) 49
 Balance
 (Balance/Fader) 46, 54
 Best Tuning Memory
 (BTM) 23
 Bluetooth 36
 Bluetooth setting initialization
 (Initialize) 45
 Bluetooth settings 45
 Bluetooth signal
 (Signal) 37, 45
 Button illumination
 (Key Illumination) 53

C

Card remote commander
 14, 16, 64
 Center Speaker Organizer
 (CSO) 48, 54
 Clock display (Clock) 13, 55
 Clock setting
 (Clock Adjust) 59
 Clock Time (CT) 23, 24, 52
 Crossover filter
 (Crossover Filter) 55

D

Demonstration (Demo) 55
 Dimmer level
 (Dimmer Level) 52
 Dimmer setting (Dimmer) 52
 Discs 11
 Display language
 (Language) 16, 52
 Dolby D level
 (Dolby D Level) 25
 Dolby Digital 25
 DVD audio language (Audio,
 DVD Audio Language) 25, 56
 DVD control menu
 (DVD Control) 21
 DVD direct search play
 (DVD Direct Search) 27, 56
 DVD menu 19
 DVD menu language
 (DVD Menu Language) 56
 DVD playlist play
 (DVD Playlist Play) 56
 DVD's top menu
 (Top Menu) 19, 21
 Dynamic Range Control
 (DRC) 56

E

Echo Canceller/Noise
 Canceller Mode
 (EC/NC Mode) 45
 EQ7 46, 54

F

Fader (Balance/Fader) 46, 54
 Formats 11
 Fuse 64

G

General settings (General) 52
 Gesture Command 35

H

Handsfree calling 39
 High Pass Filter (HPF) 55

I

IF 18
 Image rotate (Image Turn) 21
 Initial settings
 (Initial Setting) 16
 Intelligent Time Alignment 47
 iPod 32, 63

J

JPEG 11, 62

L

Language code 71
 List up (List) 34
 Listening position
 (Listening Position) 47, 54
 Local seek mode (Local) 18
 Low Pass Filter (LPF) 55

M

Microphone gain
 (MIC Gain) 41, 45
 Monaural mode (Mono) 18
 Monitor angle
 (Monitor Angle) 49
 Monitor type
 (Monitor Type) 57
 MP3 11, 62
 MPEG-4 11, 63
 Multi Border DVD 62
 Multi channel output
 (Multi Ch Output) 56
 Multi Session CD 62
 Multi-disc resume playback
 (Multi Disc Resume) 57

N

No signal (No Signal) 53
 NTSC 52

O

Operation sound (Beep) 52
 Output color system
 (Output Color System) 52

P

PAL 52
 Parental control settings
 (DVD Parental Control) 26, 56
 Passenger control
 (Passenger Control) 34
 Picture EQ
 (Picture EQ) 49, 55
 Play menu (Play Menu) 21
 Playable discs 11
 Playback control
 (Video CD PBC) 24, 57
 Playback settings (Visual) 56
 Program Types (PTY) 23, 24

R

Radio Data System (RDS) 23
 Rear Bass Enhancer
 (RBE) 48, 55
 Rear view camera 60
 Rear view camera input
 (Camera Input) 53, 60
 Rear view camera settings
 (Rear View Camera Setting)
 60
 Receive menu
 (Receive Menu) 18
 Repeat play
 (Repeat) 26, 28, 33
 Reset (Reset, Reset All
 Settings) 16, 58
 Resume play 21
 Ring tone (Ringtone) 45
 Rotary commander
 (Rotary Commander) 53

S

Screen aspect ratio
 (Aspect) 50, 55
 Screen settings (Screen) 55
 Security function
 (Security Control) 59
 SensMe™ 29
 Shuffle play
 (Shuffle) 26, 28, 33
 Slide show interval
 (JPEG Slide Show) 57
 Slow-motion play 21
 Sound settings (Sound) 54
 Speaker volume
 (Speaker Level) 48
 Subtitle language
 (Subtitle, DVD Subtitle
 Language) 21, 56
 Subwoofer position 47
 Subwoofer setting
 (Subwoofer) 16, 54
 Subwoofer volume
 (Balance/Fader) 46, 54

T

Touch panel calibration
 (Touch Panel Adjust) 49

U

USB device 28
 USB resume playback
 (USB Resume) 57

V

Volume 12

W

WMA 11, 62

Z

Zappin beep sound
 (Zappin Beep) 57
 Zappin playback time
 (Zappin Playing Time) 57
 ZAPPIN™ 35

**If you have any questions/problems
regarding this product, try the following:**

1 *Read Troubleshooting in these
Operating Instructions.*

2 *Reset the unit.*

Note: Stored data may be erased.

3 *Please contact (U.S.A. only);*

Call 1-800-222-7669

URL <http://www.SONY.com>

<http://www.sony.net/>

Sony Corporation Printed in Thailand

XAV-70BT
4-164-314-11 (1)