



# **ATLAS<sup>®</sup>** 4500 Multimode Station

## Technical Manual

Copyright © 2016 by EF Johnson Technologies, Inc.

The EFJohnson Technologies logo and StarGate are trademarks of EF Johnson Technologies, Inc. ATLAS is a registered trademark of EFJohnson Technologies. All other company and/or product names used in this manual are trademarks and/or registered trademarks of their respective manufacturers.

*Information in this manual is subject to change without notice.*

ATLAS 4500 Multimode Station Technical Manual

July 2016

# ATLAS 4500 Multimode Station Technical Manual

July 2016

<b>Section 1 - Introduction</b>	<b>1-1</b>
Using This Manual . . . . .	1-1
Audience . . . . .	1-1
Manual Organization . . . . .	1-1
Safety Information . . . . .	1-2
Safety Precautions . . . . .	1-2
Hazardous Substances . . . . .	1-2
Warnings and Cautions . . . . .	1-3
Regulatory Information . . . . .	1-3
FCC Part 15.19 Warning Statement . . . . .	1-3
FCC Part 15.21 Warning Statement . . . . .	1-4
FCC Part 15.105(b) Warning Statement . . . . .	1-4
IC RSS-GEN, Sec 8.4 Warning Statement . . . . .	1-4
IC RSS-GEN, Sec 8.3 Warning Statement . . . . .	1-4
IC RSS-102, Sec 2.6 Warning Statement Requirements . . . . .	1-5
<b>Section 2 - Product Overview</b>	<b>2-1</b>
Functional Description . . . . .	2-1
Architecture . . . . .	2-2
Usability and Maintainability . . . . .	2-2
Design and Performance . . . . .	2-2
Hardware Description . . . . .	2-3
Block Diagram . . . . .	2-3
Front Panel Indicator LEDs . . . . .	2-4
Rear Panel Connectors . . . . .	2-5
Software Description . . . . .	2-6
Specifications . . . . .	2-6
<b>Section 3 - Installation and Configuration</b>	<b>3-1</b>

## Table of Contents (continued)

Rack Installation .....	3-1
Connections .....	3-1
Initial Configuration .....	3-1
<b>Section 4 - Alignment</b>	<b>4-1</b>
<hr/>	
<b>Section 5 - Maintenance</b>	<b>5-1</b>
<hr/>	
Software Updates .....	5-1
<b>Section 6 - Technical Support and Service</b>	<b>6-1</b>
<hr/>	
Contacting EFJohnson .....	6-1
Gather Information Before Calling EFJohnson .....	6-1
Contact Information .....	6-1
Product Warranty and Repair .....	6-2
Online Product Registration .....	6-3
Returns for Repairs .....	6-3
Replacement Parts .....	6-3
Internet Home Page .....	6-4
<b>Appendix A - 700/800 MHz Circuit Descriptions</b>	<b>A-1</b>
<hr/>	
767-870 MHz Exciter Module .....	A-1
General Description .....	A-2
Schematic Description .....	A-2
<i>Frequency Synthesizers</i> .....	A-2
<i>TX VCO Board</i> .....	A-3
<i>Reference Clocks</i> .....	A-3
<i>RF Carrier Generation &amp; Modulation</i> .....	A-4
<i>RF Filter Amp Section</i> .....	A-4
<i>DPD Loop</i> .....	A-5
<i>Exciter DC Supplies</i> .....	A-6
792-825 MHz Receiver Module .....	A-6
General Description .....	A-6
Schematic Description .....	A-7
<i>Frequency Synthesizer</i> .....	A-7
<i>RX VCO Board</i> .....	A-7
<i>Reference Clock</i> .....	A-8

## Table of Contents (continued)

<i>Front End</i> .....	A-8
<i>90 MHz IF Section</i> .....	A-8
<i>Receiver DC Supplies</i> .....	A-9
<b>760-870 MHz Power Amplifier</b> .....	<b>A-9</b>
General Description .....	A-9
Schematic Description .....	A-10
<i>General</i> .....	A-10
<i>Attenuator</i> .....	A-10
<i>Driver Module</i> .....	A-10
<i>Output Power Amp</i> .....	A-10
<i>Power Coupler</i> .....	A-11
<i>Power Detector</i> .....	A-11
<i>Harmonic Filter</i> .....	A-11
<i>PTT Power Control</i> .....	A-11
<i>Auxiliary Circuits</i> .....	A-11
<b>Controller Board</b> .....	<b>A-11</b>
General Description .....	A-12
Schematic Description .....	A-12
<i>PA Interface</i> .....	A-12
<i>Exciter Interface</i> .....	A-13
<i>RX Interface</i> .....	A-13
<i>DSP Interface</i> .....	A-13
<i>Fan Control</i> .....	A-14
<i>External Port and Serial Links</i> .....	A-14
<i>Auxiliary</i> .....	A-14
<i>Firmware</i> .....	A-15
<b>Audio Logic Board</b> .....	<b>A-15</b>
General Description .....	A-15
Schematic Description .....	A-16
<b>Power Supply</b> .....	<b>A-16</b>
General Description .....	A-16
Schematic Description .....	A-16
<i>Mains-to-48V PSU</i> .....	A-16
<i>Filters</i> .....	A-16
<i>Switch Mode DC-to-DC Convertors</i> .....	A-17

## Table of Contents (continued)

# List of Figures

Figure		Page
2.1	ATLAS 4500 Introductory View .....	2-2
2.2	Block Diagram .....	2-3
2.3	Front Panel .....	2-4
2.4	Rear Panel and Connectors.....	2-5

## List of Figures (continued)

Figure	Page
--------	------

---



# List of Tables

Table		Page
2.1	Front Panel LEDs . . . . .	2-4
2.2	Rear Panel Connectors . . . . .	2-6
2.3	General Specifications . . . . .	2-7
2.4	Transmitter Specifications . . . . .	2-7
2.5	Receiver Specifications . . . . .	2-8
2.6	Standards Compliance . . . . .	2-8
6.1	Customer Service Contact Information . . . . .	6-2

## List of Tables (continued)

Table	Page
-------	------



# Introduction

This section contains information on the following topics:

- Using This Manual
- Safety Information
- Regulatory Information

## 1.1 Using This Manual

This manual is the core document for information on ATLAS® 4500 Multimode Station installation, new configuration, administration, and maintenance.

### 1.1.1 Audience

---

This manual is intended for technical support personnel, system and network administrators, who install, configure, and maintain the ATLAS 4500.

### 1.1.2 Manual Organization

---

This product manual will help you configure and use the ATLAS 4500. This manual is organized into sections to assist you in locating information quickly and efficiently. It contains the following sections:

- Product Overview
- Installation and Configuration
- Alignment
- Maintenance

- Technical Support and Service

## 1.2 Safety Information

### 1.2.1 Safety Precautions

---

These safety precautions, warnings and cautions advise personnel of specific hazards that may be encountered during the procedures contained in this document. Control measures are required to prevent injury to personnel, and damage to equipment and the operating environment.

Before beginning the installation or any maintenance of this equipment, personnel are to acquaint themselves with all risk assessments relevant to the work site and the task. They must then comply with the control measures detailed in those risk assessments.

References covering safety regulations, health hazards and hazardous substances are detailed under the following **WARNINGS** section. These are referred to in the tasks, when encountered.

Adequate precautions must be taken to ensure that other personnel do not activate any equipment that has been switched off for maintenance.

### 1.2.2 Hazardous Substances

---

Before using any hazardous substance or material, the user must be conversant with the safety precautions and first aid instructions:

- On the label of the container in which it was supplied.
- On the material Safety Data Sheet.
- In any local Safety Orders and Regulations.

## 1.2.3 Warnings and Cautions

Observe all warnings and cautions when working on or around this equipment.



- **Radio frequency radiation.** A radio frequency (rf) radiation hazard exists in this equipment. To avoid rf injury, do not touch the antenna when the transmitter is in use. Do not operate transmitter with antenna disconnected.
- **Thermal or RF burns.** Do not attempt internal servicing while transmitting. Thermal or RF burns may result from touching certain components within the power amplifier module while transmitting or operating the transmitter.
- **Shock Hazard.** To minimize any possible shock hazard from an external power supply or lightning strike, the chassis of the equipment cabinet must to be connected to an electrical safety earth connection.
- **Do not operate in an explosive atmosphere.** Do not operate this equipment in the presence of flammable gases or fumes. operation of any electrical equipment in such an environment constitutes a definite safety hazard.
- **Do not substitute parts or modify the equipment.** Due to the danger of introducing additional hazards, do not install substitute or lower voltage parts to the equipment. Return to your authorized distributor.
- **Beryllium and beryllia.** Most rf power transistors and some rf power hybrids contain beryllium oxide. Refer to the appropriate safety data sheet and/or consult your local authority for correct disposal thereof.



*Electrostatic Discharge Sensitive Devices (ESDS Devices). Observe the appropriate precautions and procedures when working on, or in the vicinity of, this equipment to avoid personal injury and/or damage to the equipment*

## 1.3 Regulatory Information

This section contains the following statements:

- FCC Part 15.19 Warning Statement
- FCC Part 15.21 Warning Statement
- FCC Part 15.105(b) Warning Statement
- IC RSS-GEN, Sec 8.4 Warning Statement
- IC RSS-GEN, Sec 8.3 Warning Statement
- IC RSS-102, Sec 2.6 Warning Statement Requirements

### 1.3.1 FCC Part 15.19 Warning Statement

This device complies with Part 15 of the FCC rules. Operation is subject to the following two conditions:

- This device may not cause harmful interference.
- This device must accept any interference received, including interference that may cause undesired operation.

### 1.3.2 FCC Part 15.21 Warning Statement

---

The grantee is not responsible for any changes or modifications not expressly approved by the party responsible for compliance. Such modifications could void the user's authority to operate the equipment.

### 1.3.3 FCC Part 15.105(b) Warning Statement

---

This equipment has been tested and found to comply with the limits for a Class B digital device, pursuant to Part 15 of the FCC Rules. These limits are designed to provide reasonable protection against harmful interference in a residential installation. This equipment generates uses and can radiate radio frequency energy and, if not installed and used in accordance with the instructions, may cause harmful interference to radio communications. However, there is no guarantee that interference will not occur in a particular installation. If this equipment does cause harmful interference to radio or television reception, which can be determined by turning the equipment off and on, the user is encouraged to try to correct the interference by one or more of the following measures:

- Reorient or relocate the receiving antenna.
- Increase the separation between the equipment and receiver.
- Connect the equipment into an outlet on a circuit different from that to which the receiver is connected.
- Consult the dealer or an experienced radio/TV technician for help.

### 1.3.4 IC RSS-GEN, Sec 8.4 Warning Statement

---

#### **English**

This device complies with Industry Canada license-exempt RSS standard. Operation is subject to the following two conditions:

- This device may not cause interference.
- This device must accept any interference, including interference that may cause undesired operation of the device.

#### **Français**

Le présent appareil est conforme aux CNR d'Industrie Canada applicables aux appareils radio exempts de licence. L'exploitation est autorisée aux deux conditions suivantes:

- L'appareil ne doit pas produire de brouillage.
- L'utilisateur de l'appareil doit accepter tout brouillage radioélectrique subi, même si le brouillage est susceptible d'en compromettre le fonctionnement.

### 1.3.5 IC RSS-GEN, Sec 8.3 Warning Statement

---

#### **English**

This radio transmitter (identify the device by certification number, or model number if Category II) has been approved by Industry Canada to operate with the antenna types listed below with the maximum permissible gain and required antenna impedance for each antenna type indicated. Antenna types not included in this list, having a gain greater than the maximum gain indicated for that type, are strictly prohibited for use with this device.

Immediately following the above notice, the manufacturer shall provide a list of all antenna types approved for use with the transmitter, indicating the maximum permissible antenna gain (in dBi) and required impedance for each.

### **Français**

Le présent émetteur radio (identifier le dispositif par son numéro de certification ou son numéro de modèle s'il fait partie du matériel de catégorie I) a été approuvé par Industrie Canada pour fonctionner avec les types d'antenne énumérés ci-dessous et ayant un gain admissible maximal et l'impédance requise pour chaque type d'antenne. Les types d'antenne non inclus dans cette liste, ou dont le gain est supérieur au gain maximal indiqué, sont strictement interdits pour l'exploitation de l'émetteur.

## **1.3.6 IC RSS-102, Sec 2.6 Warning Statement Requirements**

---

The applicant is responsible for providing proper instructions to the user of the radio device, and any usage restrictions, including limits of exposure durations. The user manual shall provide installation and operation instructions, as well as any special usage conditions, to ensure compliance with SAR and/or RF field strength limits. For instance, compliance distance shall be clearly stated in the user manual.

The user manual of devices intended for controlled use shall also include information relating to the operating characteristics of the device; the operating instructions to ensure compliance with SAR and/or RF field strength limits; information on the installation and operation of accessories to ensure compliance with SAR and/or RF field strength limits; and contact information where the user can obtain Canadian information on RF exposure and compliance. Other related information may also be included.







# Product Overview

This chapter contains the following sections:

- Functional Description
- Hardware Description
- Software Description
- Specifications

## 2.1 Functional Description

The ATLAS 4500 (Figure 2.1) is a fully software-definable IP-based linear base station that operates in P25 Phase 1 and P25 Phase 2. It has both analog and P25 mixed-mode capabilities. It is available in a range of frequency bands including VHF, UHF, and 700/800 MHz.

Figure 2.1 ATLAS 4500 Introductory View



## 2.1.1 Architecture

---

- Leverages a common hardware platform to support the following:
  - 12.5 kHz, 20 kHz, and 25 kHz Analog
  - 12.5kHz FDMA P25 Phase I
  - 6.25 kHz P25 Phase 2 TDMA
- Operates in the following modes:
  - Analog/P25 Conventional
  - P25 Trunked
  - Simulcast
- Smallest P25 Phase 2 base station in the industry packaged in an ultra-compact 2RU size chassis maximizing rack space usage
- AC or DC power input
  - AC power input can be 90-264 VAC
  - DC power input can be 24-58 VDC

## 2.1.2 Usability and Maintainability

---

- Modular architecture allows flexible expansion of sites and seamless scalability of the system.
- Interactive front panel design displays status and diagnostics for rapid troubleshooting.
- Flexible software upgrades

## 2.1.3 Design and Performance

---

- Improved multi-band receiver design provides higher sensitivity along with very high intermodulation immunity for congested prime site locations.

- High-power ultra linear ultra compact RF power amplifier uses digital and RF techniques and components that greatly simplify operation
- Full-spectrum coverage in VHF, UHF, and 700/800 MHz

## 2.2 Hardware Description

This section contains information on the following topics:

- Block Diagram
- Front Panel Indicator LEDs
- Rear Panel Connectors

### 2.2.1 Block Diagram

The block diagram in Figure 2.2 shows the interconnection and communication paths between ATLAS 4500 internal components.

Figure 2.2 Block Diagram

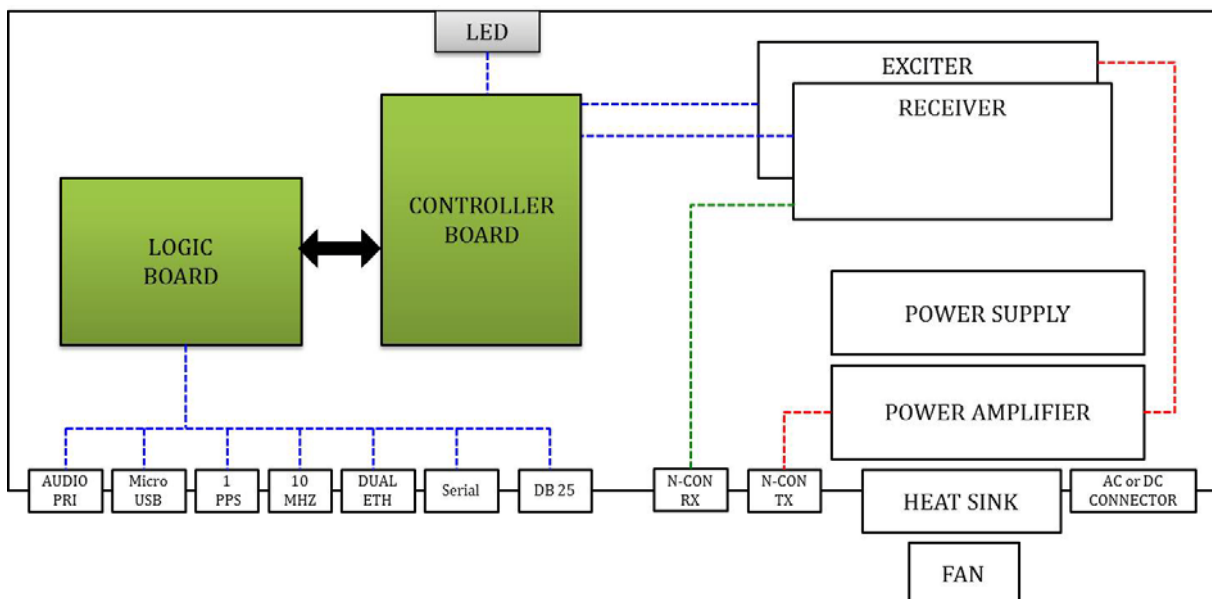

## 2.2.2 Front Panel Indicator LEDs

Figure 2.3 shows the ATLAS 4500 front panel. Table 2.1 contains descriptions of the front panel indicator LEDs.

Figure 2.3 Front Panel

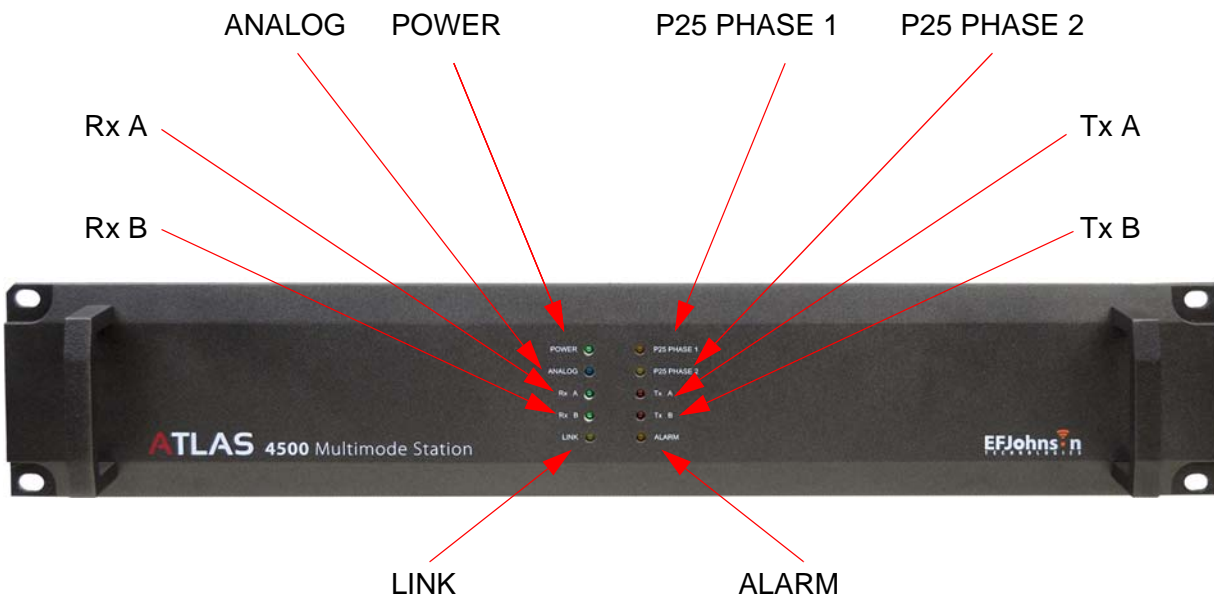

Table 2.1 Front Panel LEDs

LED	Color	Meaning (if on)
POWER	Aqua	Power is on
ANALOG	Blue	Station is operating in analog mode
Rx A	Green	Station is receiving in analog mode, P25 Phase 1 mode, or Slot 1 in P25 Phase 2 mode
Rx B	Green	Station is receiving in Slot 2 in P25 Phase 2 mode
LINK	Yellow	Link is up
P25 PHASE 1	Orange	Station is operating in P25 Phase 1 mode
P25 PHASE 2	Yellow	Station is operating in P25 Phase 2 mode
Tx A	Red	Station is transmitting in analog mode, P25 Phase 1 mode, or Slot 1 in P25 Phase 2 mode
Tx B	Red	Station is transmitting in Slot 2 in P25 Phase 2 mode
ALARM	Orange	There is an outstanding alarm

## 2.2.3 Rear Panel Connectors

Figure 2.4 shows the ATLAS 4500 rear panel and its connectors. Table 2.2 contains descriptions of the connectors.

Figure 2.4 Rear Panel and Connectors

Connectors marked by \* connect to the ATLAS 4500 logic card

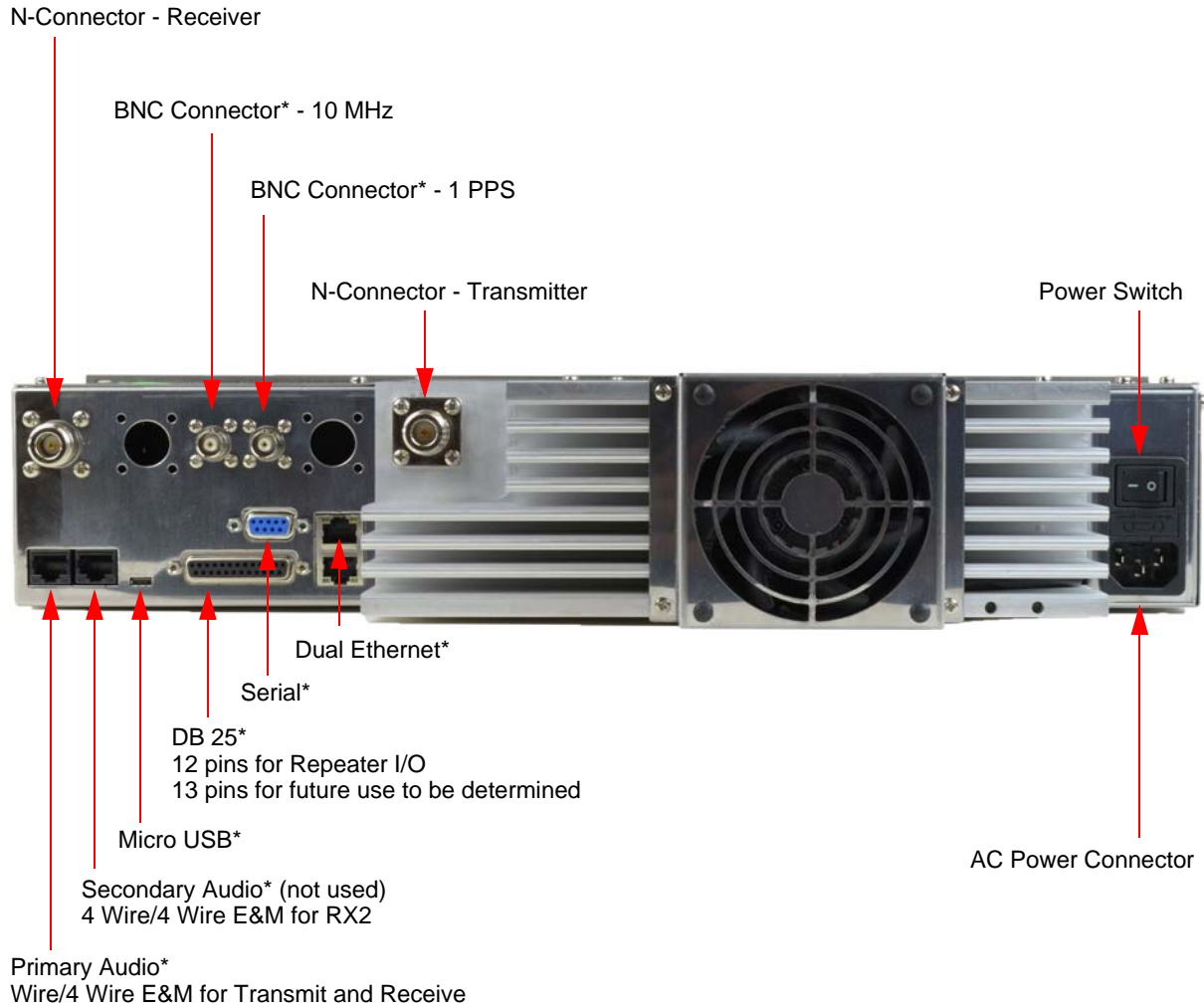

**Table 2.2** Rear Panel Connectors

Connector	Type	Function
Primary Audio	RJ 45 socket, 8 pin	Primary 4-Wire/4-Wire E&M Connection. Used to transmit over 4-wire or receive over 4-Wire from the receiver
Secondary Audio	RJ 45 socket, 8 pin	Not used (Secondary 4-Wire/4-Wire E&M Connection. Designed to receive audio over 4-wire from optional Receiver 2.)
BNC Connector - 1 PPS	BNC (F)	1 pulse per second input from the GPS receiver
BNC Connector - 10 MHz	BNC (F)	10 MHz reference from the frequency reference
Dual Ethernet	Dual RJ47	Double stacked RJ 47 Ethernet connector. Connects to the router/switch.
Serial	Serial (F)	DB9 connector used to provide console access to the logic card and the controller board (for debugging, etc.)
DB 25	DB25 (F)	General purpose 25-pin connector. 12 pins to be used for Repeater I/O and 13 pins will be used for miscellaneous functions.
N-Connector - Receiver 1	N(F)-Type	N-Type connector to connect the primary receiver to the multicoupler.
N-Connector - Transmitter	N(F)-Type	N-Type connector to connect the transmitter to the isolator/combiner.
AC Power Connector	IEC-60320-C14 Inlet	AC power input

## 2.3 Software Description

Administrators use the ATLAS® 6100/6200 Network Management System (NMS) to configure and maintain the ATLAS 4500. Refer to the *ATLAS 6100/6200 Network Management System (NMS) Technical Manual*.

## 2.4 Specifications

Table 2.3 summarizes ATLAS 4500 general specifications. Table 2.4 summarizes ATLAS 4500 transmitter specifications. Table 2.5 summarizes ATLAS 4500 receiver specifications. Table 2.6 summarizes ATLAS 4500 standards compliance.

**Table 2.3** General Specifications

Parameter	Values
Mounting	19" rack or shelf
Dimensions (Height x Width x Depth)	3.5" x 19" x 17.9" (89 x 483 x 455mm)
Weight	24.25 pounds (11 kg)
Operating Temperature Range	-22°F to +140°F (-30°C to +60°C)
Power Requirements	AC: 90-264 VAC, 47-63 Hz or DC: 24-58 VDC positive or negative ground
Power Consumption	100 W Tx 430 W Rx 28 W
RF Interconnects	Tx: N Female Rx: N Female
Channel Spacing	12.5 kHz
FCC Compliance	Parts 15 and 90
Modulation	TX: C4FM, H-DQPSK (Linear and Linear Simulcast) RX: C4FM, H-CPM, FM

**Table 2.4** Transmitter Specifications

Parameter	VHF	UHF	700 / 800 MHz
Frequency Range	136-174 MHz	380-520 MHz	763-776 MHz, 850-870 MHz
RF Power Output	1-100 Watts		
Electronic Switching Bandwidth	Full Bandwidth		
Duty Cycle	100%		
Output Impedance	50 $\Omega$		
Spurious Emissions	90 dB		
Harmonic Emissions	90 dB		
Modulation Fidelity	3%		
Intermodulation Attenuation	40 dB 80 dB With External Isolator		
Audio Response	As per TIA		
Analog Audio Distortion	2%		
Frequency Stability [-22°F to +140°F (-30°C to +60°C)]	1 PPM (Internal) 0.1 PPM (External Ref: GPS Synchronized)		
Digital Emission Designator	8K10F1E, 8K10F1D, 8K10F7E		
Analog Emission Designator	11K0F3E	11K0F3E	16K0F3E, 14K0F3E

**Table 2.4** Transmitter Specifications (continued)

Parameter	VHF	UHF	700 / 800 MHz
Analog FM Hum & Noise (S/N Ratio)	45 dB		
Maximum Deviation (Analog)	± 2.5 kHz	± 2.5 kHz	± 5 kHz
Maximum Deviation (Digital)	± 3110 Hz	± 3110 Hz	± 3110 Hz

**Table 2.5** Receiver Specifications

Parameter	VHF	UHF	700 / 800 MHz
Frequency Range	136-174 MHz	380-520 MHz	792-825 MHz
Analog Sensitivity: 12dB SINAD	-119 dBm	-119 dBm	-119 dBm
Digital Sensitivity: for 5% BER	-119 dBm	-119 dBm	-119 dBm
Signal Displacement Bandwidth	± 1 kHz		
Frequency Stability [-22°F to +140°F (-30°C to +60°C)]	0.5 PPM		
Analog Adjacent Channel Rejection (TIA603D)	72 dB		
Digital Adjacent Channel Rejection	60 dB		
Intermodulation Rejection	82 dB		
Spurious and Image Response Rejection	90 dB		
Audio Response	+1, -3 dB from 6 dB per octave de-emphasis 300-3000 Hz referenced To 1000 Hz at line output		
Analog Audio distortion (at 1000 Hz)	2%		
Digital Audio distortion (at 1000 Hz)	As per TIA		
Analog Hum & Noise (TIA)	45 dB		
Digital Hum & Noise (TIA)	As per TIA		
RF Input Impedance	50 Ω		

**Table 2.6** Standards Compliance

EF Johnson stations comply with the following standard specifications	
Standard	Specification
P25 Digital Operation	TIA-102.CAAB-D
Digital Phase 2 (TDMA) Operation	TIA-102.CCAB-A
Analog FM Operation	TIA 603-D
EMI/EMC	NTIA Manual Chapter 5
PSTN Line Isolation	FCC Part 68 (USA)









# Installation and Configuration

This chapter contains the following sections:

- Rack Installation
- Connections
- Initial Configuration

## 3.1 Rack Installation

EFJohnson performs all rack installation before delivering the ATLAS 4500 to the customer. Refer to Section 6 for information on obtaining technical support and service.

## 3.2 Connections

EFJohnson makes all ATLAS 4500 cable connections for the customer. Refer to Section 6 for information on obtaining technical support and service.

## 3.3 Initial Configuration

EFJohnson performs all initial configuration before delivering the ATLAS 4500 to the customer. Refer to Section 6 for information on obtaining technical support and service.

Administrators use the ATLAS 6100/6200 Network Management System (NMS) to configure and maintain the ATLAS 4500. Refer to the *ATLAS 6100/6200 Network Management System (NMS) Technical Manual*.



# Alignment

The ATLAS 4500 does not require alignment. Refer to Section 6 for information on obtaining technical support and service.





# Maintenance

The ATLAS 4500 contains no parts that the customer may maintain. Refer to Section 6 for information on obtaining technical support and service.

## 5.1 Software Updates

Administrators use the ATLAS 6100/6200 Network Management System (NMS) to perform software updates for the ATLAS 4500. Refer to the *ATLAS 6100/6200 Network Management System (NMS) Technical Manual*.





# Technical Support and Service

EFJohnson technical personnel are available to provide both onsite and online service, in accordance with the existing support agreement.

## 6.1 Contacting EFJohnson

If EFJohnson Technologies technical personnel are not on site, and are needed for installation assistance, contact the EFJohnson Technologies representative for your site. Check with your site engineer or site manager for contact information.

### 6.1.1 Gather Information Before Calling EFJohnson

---

When contacting EFJohnson Technologies for technical support, collect and have available all pertinent information such as specific site identification, equipment models, and any other relevant information that may be needed by technical support.

### 6.1.2 Contact Information

---

The Customer Service Department of EFJohnson Technologies provides customer assistance on technical problems and the availability of local and factory repair facilities. Regular customer service hours are 8:00 am–5:00 pm U.S. Central Time, Monday–Friday. A technical support subscription service is available or support can be purchased on an as-needed basis.

The Customer Service Department can be reached as detailed in Table 6.1.

**Table 6.1** Customer Service Contact Information

Method	
Toll-Free Phone:	(800) 328-3911 ( <i>all except Multi-Net</i> ) Extensions: <ul style="list-style-type: none"> <li>• <b>Option #1:</b> Orders and Parts</li> <li>• <b>Option #3:</b> Technical Support</li> <li>• <b>Option #4:</b> Repair Depot</li> <li>• <b>Option #5:</b> Warranty, Support, Questions</li> </ul> (800) 295-1773 ( <i>Multi-Net only</i> )
Fax:	(972) 819-0851
Email:	techsupport@efji.com

**NOTE**

*During the warranty period and/or if you have a maintenance agreement, emergency 24-hour technical support is also available at the preceding numbers during off hours, holidays, and weekends.*

You may also contact the Customer Service Department by mail. Please include all information that may be helpful in solving your problem.

Customer Service Department  
 EFJohnson Technologies  
 1440 Corporate Drive  
 Irving, TX 75038-2401

## 6.2 Product Warranty and Repair

The warranty statement for EFJohnson equipment is available from your product supplier or from:

Warranty Department  
 EFJohnson Technologies  
 1440 Corporate Drive  
 Irving, TX 75038-2401  
 (800) 328-3911

This information may also be requested from the Warranty Department by phone (See Table 6.1.). The Warranty Department may be contacted for warranty service reports, claim forms, or any other questions concerning warranties or warranty service.

## 6.2.1 Online Product Registration

---

EFJohnson offers greater convenience through online product warranty registration. Registering EFJohnson products online allows customers to receive warranty service and field service notices more quickly.

To register EFJohnson Technologies products online and ensure the covered warranty:

---

**Step 1** In your browser, go to <http://www.efjohnson.com/>.

---

**Step 2** Click the **Service & Support** link.

## 6.3 Returns for Repairs

Before returning equipment for repair, contact the EFJohnson Customer Service Department at the appropriate number shown in Table 6.1. They may be able to suggest a solution to the problem, making return of the equipment unnecessary.

Repair service cannot be performed by customers and is not available through local authorized EFJohnson Technologies land mobile radio service centers. The equipment must be returned to the EFJohnson Technologies Repair Depot. However, before returning equipment, contact the Customer Service Department Repair Depot for the correct “Ship To” address.

## 6.4 Replacement Parts

Replacement parts can be ordered directly from the Service Parts Department. To order parts by phone, dial the toll-free number and select the Orders and Parts extension specified in Table 6.1. When ordering, please supply the part number and quantity of each part ordered. EFJohnson dealers also need to give their account numbers. If there is uncertainty about the part number, include the designator (C512, for example) and the model number of the equipment the part is from.

You may also send your order by mail or fax.

Service Parts Department  
EFJohnson Technologies  
1440 Corporate Drive  
Irving, TX 75038-2401  
Fax: (800) 328-3911

## 6.5 Internet Home Page

EFJohnson Technologies has an Internet site that can be accessed for information on the company about such things as products, systems, and regulations. The address is

<http://www.efjohnson.com/>



# 700/800 MHz Circuit Descriptions

This chapter contains descriptions of the following 700/800 MHz ATLAS 4500 internal components. For each of the following components, this chapter contains a general description and a schematic description:

- 767-870 MHz Exciter Module
- 792-825 MHz Receiver Module
- 760-870 MHz Power Amplifier
- Controller Board
- Audio Logic Board
- Power Supply

## A.1 767-870 MHz Exciter Module

This section contains information on the following Exciter Module components:

- Frequency Synthesizers
- TX VCO Board
- Reference Clocks
- RF Carrier Generation & Modulation
- RF Filter Amp Section
- DPD Loop
- Exciter DC Supplies

## A.1.1 General Description

---

The Exciter module generates the low level RF transmitter signal that is amplified to nominal output power level by the Power Amplifier. The exciter module consists of two circuit boards. A Voltage Controlled Oscillator (VCO) board and an RF board with associated frequency synthesizers, a modulation controller, filtering circuits and internal power supply circuits. Also included is circuitry for an error loop system to improve transmitter linearity.

Output frequency programming is achieved by using serial data connections to an external controller.

If an external frequency reference is desired, the exciter can be fed with an external 10 MHz signal. Otherwise it has an internal 10 MHz reference oscillator.

## A.1.2 Schematic Description

---

### A.1.2.1 Frequency Synthesizers

There are 4 synthesizers in the MDM Exciter: The main synthesizer, and 3 synthesizers used in the error loop section.

The Synthesizer O/P from the VCO board on SKU-1 is split to the dual fractional-N synthesizer IC6 main divider input and the error loop first mixer LO amp IC16.

This signal is compared with the 10 MHz reference oscillator frequency and the correction voltage from the synthesizer's charge pump output is filtered then amplified by the non-inverting low noise op amp IC10. This correction voltage is fed back to the VCO to maintain loop lock as well as being fed to the Controller through TX VCO VOLTS CN3-14. A lock detect signal from IC6 is also fed to the Controller through TX LD CN3-16. The op amp IC10 uses a 25-V power supply generated by IC4 to provide a wide tuning range voltage to frequency control varicap diodes located on the VCO board. The VCOs power is supplied by a dynamic filter TR6 and 8 V regulator IC11.

A serial flash IC47 contains synthesizer band, charge pump settings and configuration data.

This is read by the Controller through the I2C bus to set the synthesizer.

Frequency programming data for the exciter is sent to Synthesizer IC6 from the Controller through serial data (CN3-18) under the control of the Clock (CN3-15) and Strobe (CN3-17) lines.

Synthesizer IC28 and associated components provide a reference of 345.6 MHz for IC31 DDS IC. This 345.6 MHz signal is frequency locked to the 10 MHz main reference clock. The 345.6 MHz clock is divided by 8 within IC31 and outputs a 43.2 MHz clock that drives IC32 FPGA.

Synthesizer IC24 and associated components provide a reference of 120.45 MHz for the error loop second mixer LO amp IC21. This 120.45 MHz signal is frequency locked to the 10 MHz main reference clock.

Synthesizer IC22 and associated components provide a reference of 40.32 MHz for the MCLK line to the A/D IC 31. This 40.32 MHz signal is frequency locked to the 43.2 MHz FPGA ADLMX line.

### A.1.2.2 TX VCO Board

The plug-on VCO board consists of a 2-band dielectric resonator oscillator with common base oscillator for low phase noise. This is contained in a shielded compartment in the case. The VCO provides frequencies over 879.64 – 894.64 MHz and 969.64 – 989.64 MHz ranges.

The main RF VCO OUT on SKJ-6 is first buffered by a very high isolation circuit consisting of the MMIC on the VCO, then on main board, a 3 dB pad and an amplifier IC17. It is then up-converted at mixer X8 and used to generate the main transmit RF amplifier signal source.

Each band is switched under control of the Controller. 2 MMIC buffers feed the synthesizer and main outputs. The power supply to the VCO consists of an 8-V regulator and active filter for maximum noise rejection located on the exciter PCB. The 8-V supply consists of IC11, TR6 and associated components.

The PLL control line varies VCO frequency (SKT – 1).

### A.1.2.3 Reference Clocks

A stable 10 MHz reference is generated by X1—a temperature controlled crystal oscillator, and is fed to the synthesizer IC6 through select switch IC7. A detector circuit senses the presence of an external 10 MHz reference  $> \sim 0$  dBm (0.6 Vpp) and informs the Controller through EXT REF DET CN3 – 10. IC7 switches between this internal oscillator and an external 10 MHz reference source fed into CN4 under control of the Controller through EXT OSC SW CN3-13.

Buffer transistors TR2 and TR3 provide a fast slew rate clock REF IN for better phase noise. This feeds a digital buffer IC 29 generating a fast edge 10MHz clock for the 345.6 MHz and 120.47 MHz synthesizers.

**NOTE**

*An external 10 MHz clock must have low phase noise/jitter and have a nominal level of 10 dBm (1.8 Vpp)*

There is a time delay to re-initialize the exciter after changing from internal to external clock or external to internal clock, due to synthesizers needing re-programming by the controller.

### A.1.2.4 RF Carrier Generation & Modulation

RF carrier modulation type Phase 1 FM or LSM and Phase 2 H-DQPSK is generated within IC31 FPGA and IC32 DDS from a serial digital stream on the I2S bus lines coming from the external digital signal processor (DSP) and fed into Pins 5, 7 and 8 of CN3. The initial setup for the FPGA internal Arm controller is done through the I2C bus on Pins 9 and 12 of CN3. The ARM controller inside the FPGA IC has a 20 MHz crystal clock and internal VCO.

The FPGA provides raised cosine filtering of the I/Q data and is sent in digital form to the DDS digital I/Q modulator. The DDS IC generates a differential 119.64 MHz I/Q modulated signal. This is filtered by the SAW filter F5 into the high level mixer X8 input.

The VCO output signal is mixed with the 119.64 MHz modulated signal by mixer X8 (O/P of ~ -23 dBm) at the desired transmitter output frequency.

### A.1.2.5 RF Filter Amp Section

The RF output of the mixer X8 is fed through the first RF band pass filter, then the first MMIC amp, then the second RF band pass filter, and finally the second MMIC amp before being output to the Power Amplifier module through CN1.

The 760 – 870 MHz band pass filter function is supplied by selectable bands. 2 bands are fitted as standard 760- 775 MHz and 850 – 870 MHz.

Each first band pass filter I/P is fed by switch IC20, then the filter output into IC18, then first amp IC2, to make up a selector circuit that switches the frequency band programmed by the Controller. This is followed by first MMIC amp IC2 and next a fixed attenuator.

Each second filter I/P is fed by Switch IC26, then the filter output into IC19, for the frequency band of operation. The second RF MMIC amp IC23 provides gain for this stage to the O/P at a ~ 13 dBm output level.



### A.1.2.6 DPD Loop

The modulator includes a Digital Pre Distortion (DPD) feedback system that corrects for distortion in the PA and allows for small adjustments to be made to the modulated RF signal output. This enables excellent overall linearity and good close in ACP performance for the transmitter.

The feedback signal from the Power Amplifier sample port comes into the exciter module through CN6 at ~ 6 dBm. This is attenuated then down-converted with the main VCO output (879.64 – 989.64 MHz) from buffer amp IC16 by mixer M1 to provide an output of 119.64 MHz. This passes through a 150 MHz low pass filter and is amplified by IC15.

The 119.64 MHz IF is down-converted with the 120.45 MHz local signal from buffer amp IC21 by mixer M2 to result in an 810 KHz IF signal.

The local oscillator for this second down converter is provided by the 120.45 MHz Synthesizer IC24 and associated components. Programming for this is provided by the FPGA IC32.

The 810 KHz IF signal is band pass filtered and then amplified by a 20 dB gain differential amplifier IC14, then further amplified by the 16 dB gain differential amplifier front end of IC31, a high performance Analog-to-Digital converter.

#### NOTE

*The sample port CN2 provides a -6 dB sample of one side of the final differential analog O/P of the 810 kHz IF at ~ -10 dBm level.*

This IF signal is sampled at a 20.16 MSps rate, then passed through an 810 kHz digital FIR band pass filter inside IC31, BW is ~ 100 kHz and decimated by 8 for a 2.5 MSps O/P rate.

The 16 bit digital samples from IC31 are read by IC32, the main FPGA/ARM for processing by internal software. An area for pre-distortion correction tables is provided by IC27 RAM. The FPGA DPD filter data is stored in the serial Flash ROM IC35.

Inside the FPGA IC the 2.52 MSps 810 kHz IF is decimated by 7 to effectively give a 1/9 converted 360 MSps 90 kHz signal plus other unwanted signals. This is then passed through a narrow 90 kHz IF band pass FIR filter to removing other products and noise.

The correction software in the FPGA/ARM has a short initial delay acquisition followed by I/Q correction. This allows corrections to reduce overall distortion products at the PA output.

### A.1.2.7 Exciter DC Supplies

The exciter is supplied a nominal 13.8 V through CN3-2. This input supply is then distributed to IC1, IC4, IC9 and IC11.

IC1 is configured as a 1 MHz buck DC-DC converter and provides the main regulated +5.2 VDC output. A shielded inductor is used to reduce fields.

IC9 is configured as a boost DC-DC converter and provides +25 V DC output for the main PLL.

IC3 is a linear regulator regulating the +5.2 V supply down to +5 VDC for linear circuits, A/D, RF amps etc.

IC30 and IC48 are linear regulators regulating the +5 V supply down to +3.3 V DC for the synthesizers.

IC33 contains multi-circuit buck DC-DC converters and low drop out regulators that provide +3.3 V, +2.5 V, +1.8 V and +1.2 V for various circuit sections in the digital portion of the exciter including the FPGA, memory and DDS etc.

## A.2 792-825 MHz Receiver Module

This section contains information on the following Receiver Module components:

- Frequency Synthesizer
- RX VCO Board
- Reference Clock
- Front End
- 90 MHz IF Section
- Receiver DC Supplies

### A.2.1 General Description

---

The receiver module converts a low level RF signal from an antenna input to a 90 MHz intermediate frequency (IF) output for processing with the DSP RX board.

Low side injection is used in the upper 2 bands, High side injection in the 2 lower bands. The module has a 30-W interface and 2 SMB connectors for RF input and 90 MHz IF output.

The receiver module consists of two circuit boards. A Voltage Controlled Oscillator (VCO) board and an RX board with associated frequency synthesizers, down converter, TCXO, filtering circuits and internal power supply circuits.

Receiver input frequency programming is achieved by using serial data connections to an external controller. A serial flash IC contains synthesizer band, charge pump settings and configuration data read by the Controller.

## A.2.2 Schematic Description

---

### A.2.2.1 Frequency Synthesizer

RF is output from the VCO board on SKU2-1. It gets applied to the fractional-N synthesizer IC6 main divider input. This signal is compared with the reference oscillator frequency and the correction voltage from the synthesizer's charge pump output, which is filtered then amplified by the non-inverting low noise Op Amp IC10. This correction voltage is fed back to the VCO to maintain loop lock. The VCO control voltage is also buffered and sent to the Controller through on RX VCO VOLTS (SK1-14). The op amp uses a 25-V power supply generated by IC4 to provide a wide tuning range voltage and good phase noise-to-frequency control varicap diodes located on the VCO board.

A second RF output from the VCO on SKT2-6 is mixed with the incoming RF and generates an IF output of 90 MHz at CN2. This VCO signal is first buffered by a very high isolation circuit consisting of a MMIC on the VCO and a 1dB pad and an amplifier (IC17) at 22 dBm.

Frequency programming data for the exciter is sent to IC6 from the Controller through a serial data (SK1-18), Clock (SK1-15), Strobe (SK1-17). A lock detect signal from IC6 is also fed to the Controller through RX LD (SK1-16).

### A.2.2.2 RX VCO Board

The plug on VCO board consists of 2 band dielectric resonator oscillators with a common base oscillator for low phase noise. This is contained in a shielded compartment in the case. The VCO provides frequencies in 2 bands for 90 MHz high side injection. The bands are 911.64 – 924.64 MHz and 924.64 – 944.64

The main RF VCO OUT on SKJ-6 is first buffered by a very high isolation circuit consisting of the MMIC on the VCO, then on the main board, a 3 dB pad and an amplifier IC17. It feeds LO to mixer X8 used to down convert the RX signal to a 90 MHz IF signal.

Each band is switched under control of the Controller. 2 MMIC buffers feed the synthesizer and main outputs. The power supply to the VCO consists of an 8-V regulator and active filter for maximum noise rejection located on the exciter PCB. The 8-V supply consists of IC11, TR6 and associated components.

The PLL control line varies VCO frequency (SKT – 1).

### A.2.2.3 Reference Clock

A stable 10 MHz reference is generated by X1—a temperature controlled crystal oscillator (TCXO), and fed to the synthesizer IC6 through an amplifier consisting of TR2 and associated components.

### A.2.2.4 Front End

The incoming signal from the antenna is connected to CN1, where it passes through a low pass filter then a limiter before amplification by IC2 (this can be linked out for higher dynamic range). After IC2 the signal is fed to a band pass filter network switched by IC19 and IC26. From here, the signal is amplified by IC34 and fed into another band pass filter network with the band in use switched by IC18 and IC20. ICs 18, 19 20 & 26 are controlled from the external Controller through 4 digital logic signals that select the correct filters for the frequency sub-band in use.

The 4 band pass filter switches use 4 lines (SK1 – 19), (SK1 – 20), (SK1 – 21), (SK1 – 22)

### A.2.2.5 90 MHz IF Section

A VCO signal generated by the synthesizer is fed into a RF mixer (X8) where it produces a fixed frequency output of 90 MHz. This IF output is then fed through an input matching network through a crystal filter (FL7) and associated output matching network and is then amplified further by IC49 and associated components. The IF signal is filtered further by crystal filters FL8A and FL8B and their matching networks before being amplified further by TR8 and associated components. The 90 MHz filtered IF output is fed for external signal processing in the DSP RX board through connector CN2.

(The 90 MHz IF O/P level is ~ -53 dBm for -100 dBm RX I/P and ~ -13 dBm for -60 dB RX I/P at 800MHz)

### A.2.2.6 Receiver DC Supplies

The exciter is supplied nominal 13.8 V through SK1-2. This input supply is then distributed to IC1 and IC4.

IC1 is configured as a buck DC-DC converter and provides a regulated +5.2 VDC output.

IC4 is configured as a boost DC-DC converter and provides +25 V DC output.

IC3 regulates +5.2 V supply down to +5 VDC.

IC48 regulates +5 V supply down to +3.3 VDC.

## A.3 760-870 MHz Power Amplifier

This section contains information on the following Power Amplifier components:

- Attenuator
- Driver Module
- Output Power Amp
- Power Coupler
- Power Detector
- Harmonic Filter
- PTT Power Control
- Auxiliary Circuits

### A.3.1 General Description

---

The PA contains the following components

- Variable attenuator
- Driver module
- Main power amp
- Cooling system and heat sensor
- Coupler for DPD system.
- Power detector
- Low pass filter
- PTT switch
- Serial flash memory and regulator

## A.3.2 Schematic Description

---

### A.3.2.1 General

The RF input is ~ 12 dBm into CN1. The PA provides 1-100 W output across 760 – 870 MHz band at the main N type connector. The Main supply is 48V at < 10A at CN3. The secondary supply is 24 V at 450 ma at CN2, and 5 V at 10 ma at CN2.

### A.3.2.2 Attenuator

CN1 at ~12 dBm enters attenuator IC1. This provides attenuation steps of 0.25 dB from a 2 dB minimum. This is used by the Controller for power control through CN2 pins 3, 4, 5 lines.

**NOTE**

*The Controller uses the PA calibration data stored in IC11 during PA calibration, FWD VOLTS from the power detector, TX frequency and O/P power settings set from the DSP to control the attenuator values dynamically.*

### A.3.2.3 Driver Module

The attenuator IC feeds an amplifier module IC2 to provide drive for the main PA amp.

This module is a high linearity low intermodulation 75-Ω power driver with ~24 dB gain, 28 dBm RF power. It operates at 24 V at 450 ma.

### A.3.2.4 Output Power Amp

The PA output power amp stage uses a high performance power FET in a Gemini package. This is mounted on a copper heat spreader plate, on a fan-cooled aluminium heat sink.

The input matching uses a 90° section 17-Ω transmission line balun. Then, a balanced matching section to a ~ 0.5-Ω Z<sub>in</sub> FET.

Input series resistors and a parallel resistor are used to prevent instability.

The output match from ~ 6 Ω Z<sub>out</sub> consists of a 2-section match, then to a 90° section 17-Ω transmission line balun to give 50-Ω feed.

### A.3.2.5 Power Coupler

The PA feeds an output RF coupler port, providing about 6 dBm at 100 W output. This is for DPD use, and is fed to the Exciter.

### A.3.2.6 Power Detector

Next, the output RF passes a directional coupler. This is used to sense PA forward and reflected power. The FWD VOLTS goes to CN – 11. REFL VOLTS goes to CN – 12.

Detector sensitivity gives ~ 3.5 V at 100 W at center of the band.

**NOTE** *A harmonic filter network is added to keep response flat.*

### A.3.2.7 Harmonic Filter

Next follows a 4-stage elliptical low pass filter inside a screened cover. This provides attenuation of all harmonics.

### A.3.2.8 PTT Power Control

The PTT line from CN – 8 controls the Switch TR2. This switches 24 V and allows PA FET bias to operate. PA bias is nominally set for 4 V at CN2 – 7 and pot-adjusted for ~3 A.

### A.3.2.9 Auxiliary Circuits

The PA contains a 3.3-V regulator IC7 with 5 V in from CN2-14, a temperature sensor TS1 on CN2 – 13, and a serial flash IC11 using I2C bus on CN2- 9, 10.

## A.4 Controller Board

This section contains information on the following Controller Board components:

- PA Interface
- Exciter Interface

- RX Interface
- DSP Interface
- Fan Control
- External Port and Serial Links
- Auxiliary
- Firmware

## A.4.1 General Description

---

The Controller PCB contains the following:

- The main microcontroller IC1 containing CPU, flash, RAM, UARTs, ports etc
- Data latches
- Serial Flash
- 3.3-V and 5-V linear regulators
- Power on reset IC
- PA I/F, etc
- Control /noise filter for the fan in the PA
- 10 MHz osc det I/P used for 10 MHz ref switch control in the Exciter
- DSP I/F port
- Exciter I/F port
- Receiver I/F port
- Relay O/P
- LED I/F
- Configuration links

## A.4.2 Schematic Description

---

### A.4.2.1 PA Interface

The interface has 14 pins. The PA interface provides 24 V 450 mA and 5 V 10 mA.

It controls the PA by means of the PTT line and the bias line [nominally 4 V at 77°F (25°C)].

The forward power and reverse power detector voltages are transferred to the controller. The PA copper plate temperature can be read through a single pulse width modulation line.

During power up, the Controller loads the PA calibration data from the Serial flash IC on the I2C bus. This bus is also used for initial PA calibration.



### A.4.2.2 Exciter Interface

The Exciter interface has 30 pins. The Exciter interface provides ~13.8 V at ~0.6 A. The interface includes:

- Synth – 4 x Lines are provided for 4 VCO controls, 3 x synth frequency setting lines, lock alarm.
- I2C bus for exciter serial flash and FPGA ARM communication from the Controller
- TXVCO volts monitor line. Exciter PTT line from the Controller,
- The main data stream using 3 x I2S data communication lines from DSP, 2 Serial data lines from the Controller board for diagnostic use.
- 1 pps line to FPGA for simulcast.
- FPGA PTT, FPGA TP G line, FPGA TP H line (initially used).
- The Controller can sense the presence of external 10 MHz reference (>~0 dBm 0.5 Vpp) using Ex ref line. The Controller can select External reference using Ext osc sw line. This is done by software control to allow correct handover.

### A.4.2.3 RX Interface

There are RX interfaces for 2 receivers. This allows a second diversity RX option. The RX connector is a 30-pin connector. Most lines are common for both. This includes 12-V and 3.3-V supplies, I2C bus for the serial flash used for synthesizer band selection and PLL gain.

The Controller sets the channel frequency through the common PLLDAT and PLLCLK and RX1 EN and RX2 EN lines. Each of the 2 VCO bands is selected by means of 2 VCO band lines. Each RX VCO control voltage can be monitored on each RX1VCO and RX2VCO line.

### A.4.2.4 DSP Interface

The DSP overall controls the base station.

The DSP control serial data (RS232) communication is sent to the Controller using a protocol. This controls modulation mode, channel frequency, power etc. The Controller then sends I2C to the Exciter and logic for PTT, sets PA power etc.

The DSP TX modulation data is sent synchronously through the I2SCLK, I2SDAT, ISFRM lines to the Exciter FPGA. The FPGA controls the clock and frame timing of this interface, where DSP provides raw data. A 1pps signal from the DSP can be provided for precise simulcast timing.

The DSP RX IF comes from the RX to DSP. The main RX1 and optional RX2 90 MHz IF signals are fed directly from the receivers to the DSP section RX sub board through coax cables from CN2.

#### A.4.2.5 Fan Control

The PA fan interface has 4 pins. 12 V Power is switched with a pulse width FET. Fan power noise spikes are attenuated by RFI network using L1 etc to eliminate noise on 12 V power.

A speed control is provided for the fan. A pulse RPM sensor allows RPM to be measured.

#### A.4.2.6 External Port and Serial Links

The Controller PCB has an external 10-pin port for diagnostic use with jumper links JMP2 and JMP3 to select Debug access to MCU position A. Debug access to Exciter position C.

The Controller can be talked to in position A of links JMP2 and JMP3 to its serial port 2 and debug or loader program used. (To use the loader JMP1 must be taken off)

The DSP I/F normally accesses controller serial port 1 but when DSP is not connected this can also be selected using links JMP4 and JMP5 Position B. (normally always A).

#### A.4.2.7 Auxiliary

The Controller PCB has 2 x 3.3 V linear regulators and a 5-V linear regulator.

It contains an interface for the 10 front panel LED indicators. (some future use) These are for Power, Analog, RXA, RXB (diversity), Link (Ethernet on), P25 phase 1 (C4 FM), P25 phase 2, TX A (time slot A), TX B (time slot B).

The CPU A/D inputs monitor voltages for Supply in (48 V), RX VCO 2, RX VCO 1, TX VCO, Forward and Reflected voltages.

The Controller sends serial data on 3 lines to the PA 7 bit attenuator ATN1, ATN2, ATN3 for SI, CLK, LE pins on the attenuator IC.

The Controller has an input port for the temperature sensor sending a pulse width modulated signal.

### A.4.2.8 Firmware

The Controller flash contains following:

- Gateway operational software to obey command protocol from the DSP. DSP sends commands to set up RF characteristics, modulation etc.
- PA power control software and temperature sensing. Fan control.
- Debug software to allow control through the PC terminal program.
- Alarm points and monitors alarms and takes corrective action
- Controls interfaces with Exciter for frequency setting and PTT indication
- Controls EEPROM reading and writing from various modules. Allows it to be controlled from the Debug point initially. Later DSP can select.
- Configuration data, serial number etc. Plug and play system for all modules. Reads config data from all modules.
- Other operational software.

## A.5 Audio Logic Board

### A.5.1 General Description

---

The Audio Logic board is the main controller for the base station.

It sends and receives serial control to the Controller using a defined protocol.

It communicates data with the Ethernet link receiving and sending data to its network.

The TX data encoding, modulation shaping, RX clock recovery, demodulation etc is done by the hardware and programming.

The TX modulation data is sent synchronously through the I2SCLK, I2SDAT, ISFRM lines to the Exciter through the Controller board.

The RX modulation is through 90 MHz IF ports, main and diversity.

## A.5.2 Schematic Description

---

The OMAP operates all external interfaces and the three serial communication devices. It also interfaces with the Controller board through a MCBSP BUS and UART.

# A.6 Power Supply

This section contains information on the following Power Supply components:

- Mains-to-48V PSU
- Filters
- Switch Mode DC-to-DC Convertors

## A.6.1 General Description

---

The base station main power supply contains the following:

- 100 – 240 VAC-to-48 VDC supply
- Mains Filter, 48 V I/P and 3 O/P Filters.
- DC to DC 5.2 V PSU
- DC to DC 13.8 V PSU
- DC to DC 24 V PSU
- Cable and connector to main Controller PCB and PA.
- Shielded case

## A.6.2 Schematic Description

---

### A.6.2.1 Mains-to-48V PSU

The base station uses a switch mode power supply 100 – 240 VAC input, 48 V 10.5 A, 500 W output. This has a temperature controlled cooling fan inside.

### A.6.2.2 Filters

The General power supply board has an EMI filter of the AC mains (inside PSU) and filter networks on the 48 V DC O/P for ripple and RFI noise.

The 3 DC to DC convertors outputs have filter networks to filter RFI noise.

### A.6.2.3 Switch Mode DC-to-DC Convertors

The 48V supply is DC / DC converted to 5 V by IC2, 13.8 V by IC1 and 24 V by IC3.

Each supply capacity is ~ 1.5 A and is fold-back protected.

