



ENGLISH

SMARTCODE 912

TOUCHPAD ELECTRONIC LEVER

Installation and User Guide

Required tools

4 AA Batteries Ruler Phillips head screwdriver

Additional Tools (depending on application)

Hammer Wood block

Kwikset Technical Support

1-866-863-6584
www.kwikset.com

Parts in the box		
Latch 	Exterior Assembly 	Interior Assembly
 "B" is not included. If needed, please contact Kwikset to order a drive-in latch for your lock.	Mounting Plate 	Fasteners 26298
Strike 	SmartKey Tool 	22044
Keys 	Spindle 	Levers
		27526 64156

1 Prepare the door and check dimensions

If drilling a new door, use the supplied template and the complete door drilling instructions available at www.kwikset.com/doorprep.

A Measure to confirm that the hole in the door is 2-1/8" (54 mm).

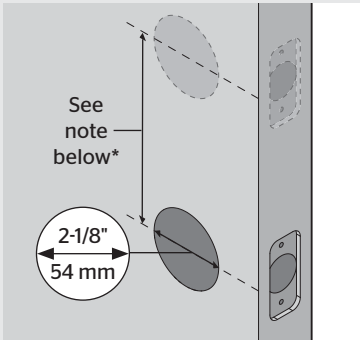

B Measure to confirm that the backset is either 2-3/8" or 2-3/4" (60 or 70 mm).

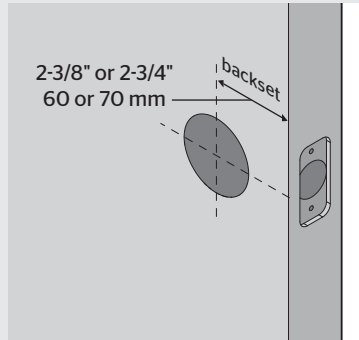

C Measure to confirm that the hole in the door edge is 1" (25 mm).

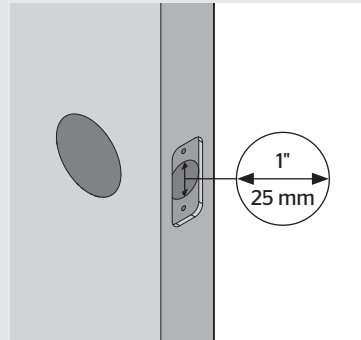

D Measure to confirm that the door is between 1-3/8" and 1-3/4" (35 mm and 44 mm) thick.

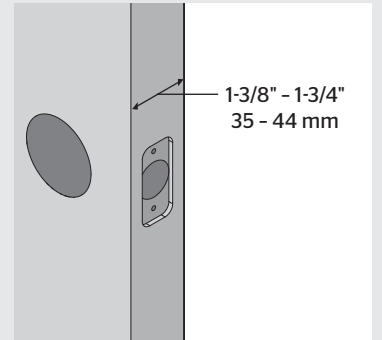

*If you are installing this lever below an existing lock or you plan to install a lock above this lever, make sure that the distance between holes is at least 6-1/2" (165 mm).

2 Install the latch and strike

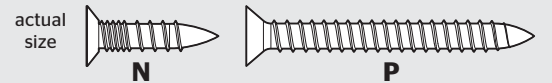

A Hold the latch in front of the door hole, with the latch face flush against the door edge.

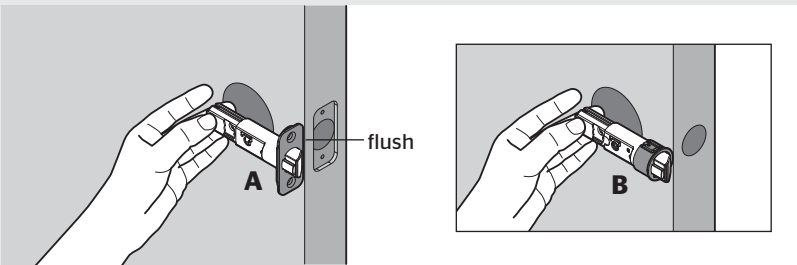

B Is the semi-circular hole of the latch centered in the door hole?

<p>YES</p> <p>No adjustment is required. Proceed to next step.</p>	<p>OR</p>	<p>NO</p> <p>Move the pin to extend the latch.</p>
---	-----------	---

C Is the door edge chiseled?

<p>YES</p>	<p>OR</p>	<p>NO</p>
<p>⚠ slant of latch bolt faces door frame</p>		<p>⚠ slant of latch bolt faces door frame</p>

D Install strike on the door frame.

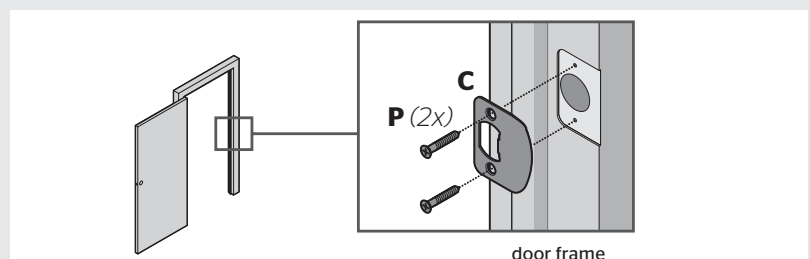

3 Install the exterior keypad, mounting plate, and spindle



A Install exterior keypad.

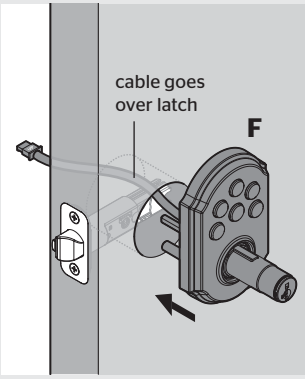

B Route cable through mounting plate.

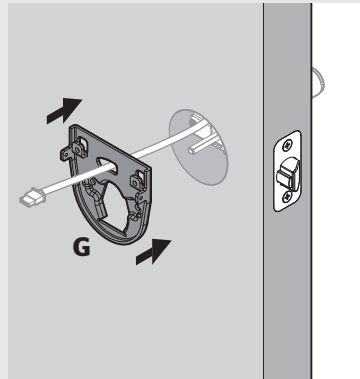

C Secure mounting plate with supplied screws.

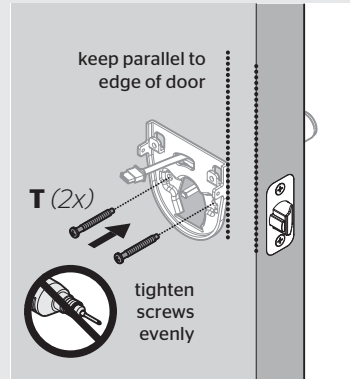

D Install spindle.

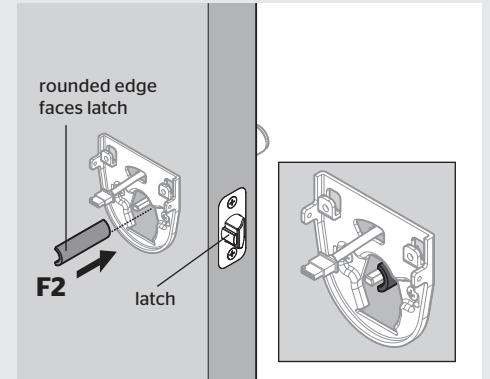

4 Install interior assembly

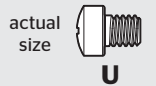

A Remove battery cover and battery pack from interior assembly.

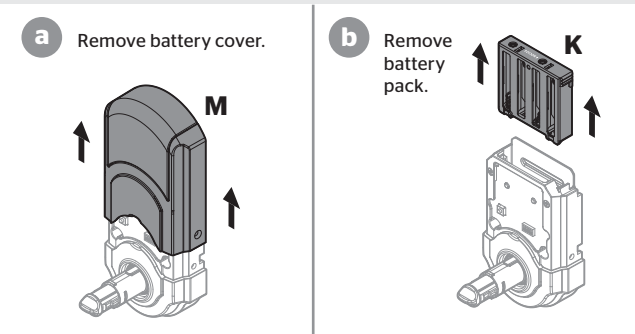

B Install interior assembly onto mounting plate.

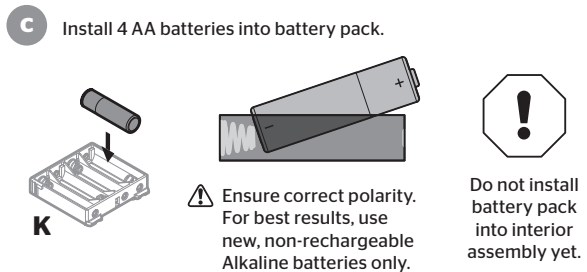
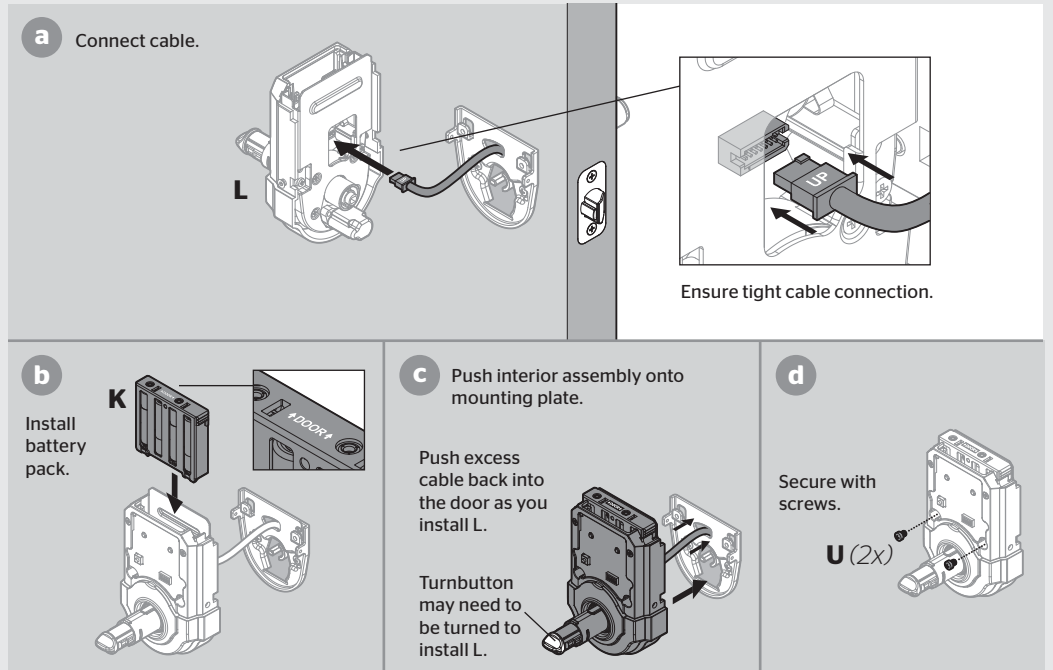

5 Install levers

A Install interior lever.

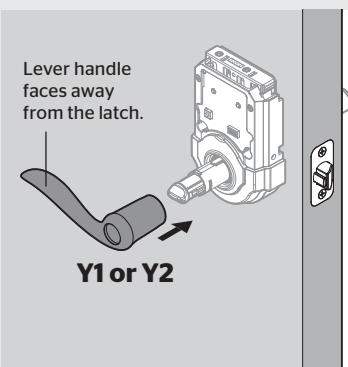

B Secure interior lever.

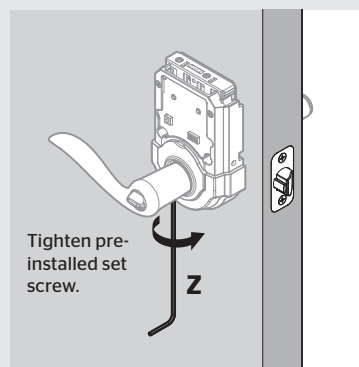

C Install exterior lever.

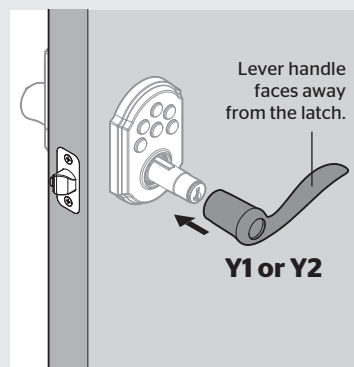

D Secure exterior lever.

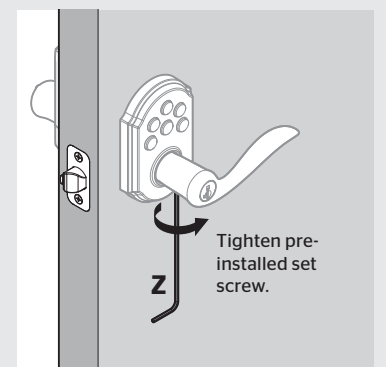

6 Test latch operation

Close door, test latch operation and make adjustments as needed:

The small bolt of the latch should not enter the strike hole. If it enters the strike hole, reposition strike.

If latch is loose in the strike, adjust the strike tab so it grips the latch bolt better when the door is closed.

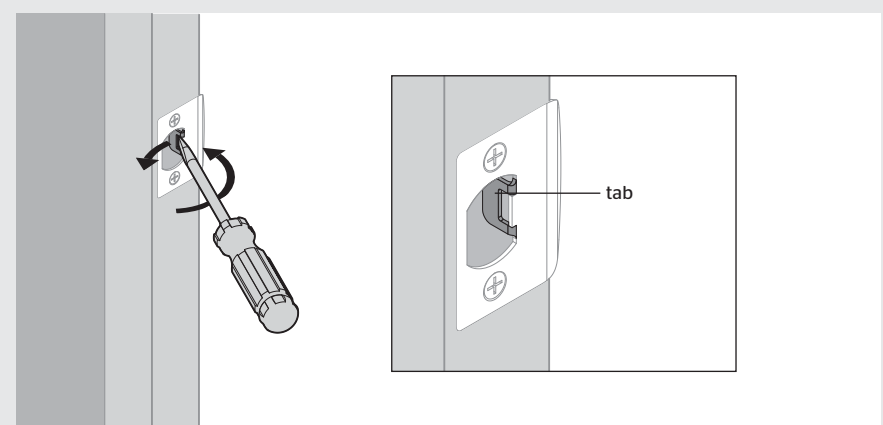
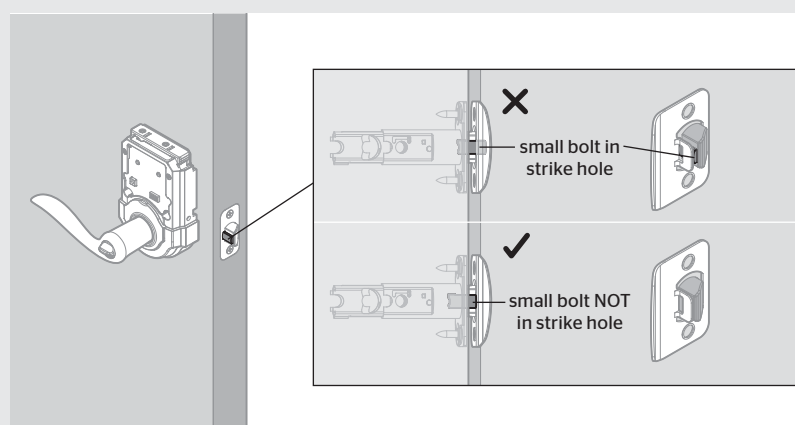

7 Pair the lock with your smart home system

If your controller is S2-compatible, please refer to the S2 Pairing Guide on the SmartCode 912 page at www.kwikset.com.

A Initiate the pairing process at your smart home controller. Refer to your smart home system instructions for more information.

B When prompted by your smart home system to initiate pairing at the lock, press button "A" on the lock interior one time. The red LED will illuminate when pairing mode has been entered.

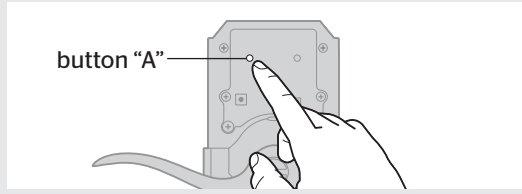

Please allow time for the controller to pair with the lock.

C If the pairing process is successful, re-name the lock in your system (if applicable).

D If pairing is unsuccessful, follow your system's instructions to remove the lock from the controller and any other network, then press button "A" on the lock one time.

Perform steps 7A-7C again.

If pairing is still unsuccessful, consult the Programming and Troubleshooting Guide on the SmartCode 912 page at www.kwikset.com.

8 Add user codes (30 max)

It is recommended that you add and delete all user codes through your smart home control system. If your system does not allow this, codes may be added directly to the lock as shown here.

Programming Timeout

If no button is pressed for 5 seconds, the system will time out and you will need to restart the procedure.

A Make sure the door is open. Press the Program button the number of times that corresponds to the user code position being programmed.

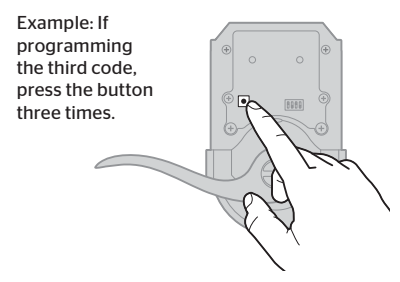

B Enter user code. A total of 30 user codes may be programmed.

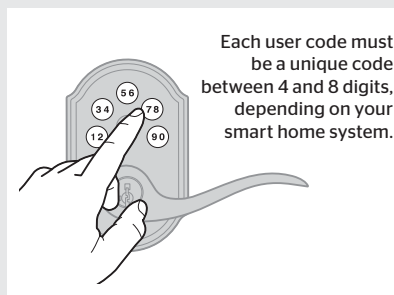

C Press Lock button once.

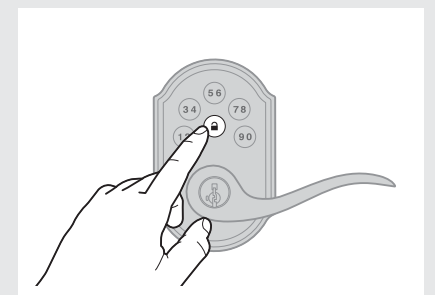

D What lights and sounds does the lock produce?

<p>One green flash with one beep*</p> <p>green</p> <p>Programming was successful.</p>	<p>or</p>	<p>Three red flashes with three beeps*</p> <p>red</p> <p>Programming was unsuccessful.</p> <p>Make sure the user code is not a duplicate and that it is between 4 and 8 digits during your next attempt.</p>	<p>or</p>	<p>Two beeps*</p> <p>Programming time out.</p> <p>Make sure not to pause for more than 5 seconds during programming.</p>
--	------------------	---	------------------	---

*Beeping sound will only be heard if switch #3 (on the lock interior) is in the on position. See "Switches and Status LED Colors" on page 4.

Mastercode

For enhanced security, a mastercode may be used when adding and deleting user codes. For more information about the mastercode, download the Programming and Troubleshooting Guide on the SmartCode 912 page at www.kwikset.com.

9 Test the lock (review normal operation)

Confirm that the code(s) added in previous step can unlock the door.

Locking the Door

Press Lock button once.

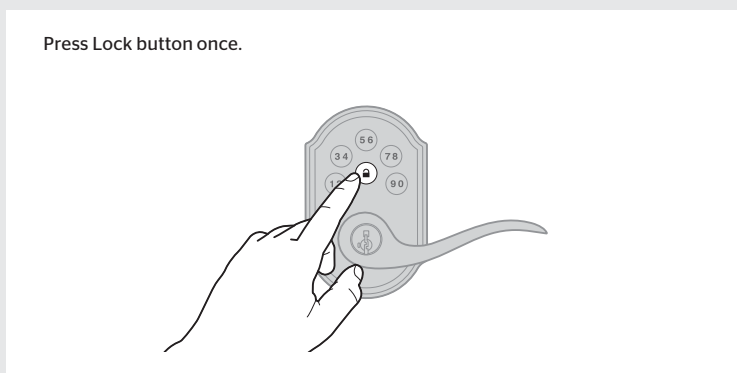

Unlocking the Door

Enter user code.

Tip: You can press the Lock button before entering your user code to light up the keypad at night.

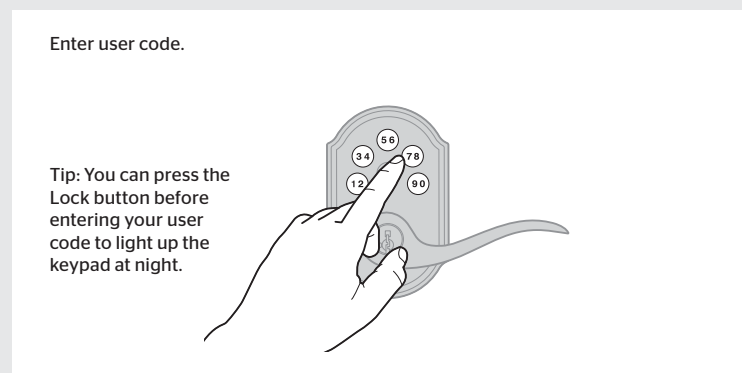

10 Re-key the lock (if needed) and install the battery cover

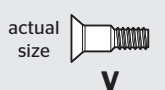

A Re-key the lock (if needed).

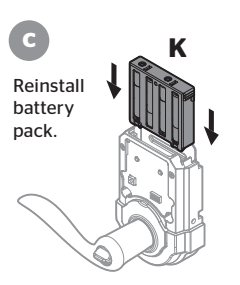
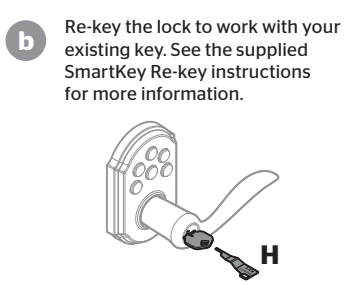
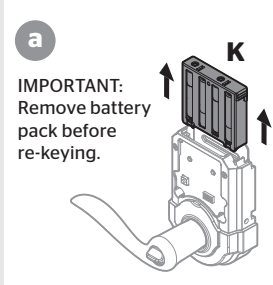

B Install the battery cover.

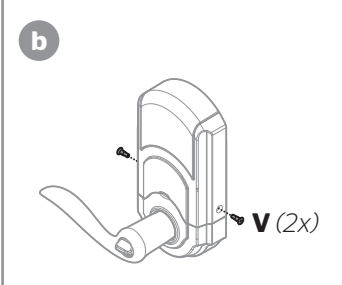
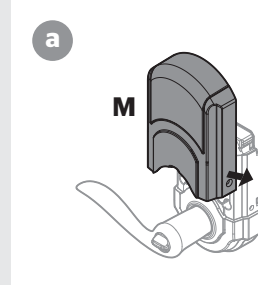

SmartCode at a Glance

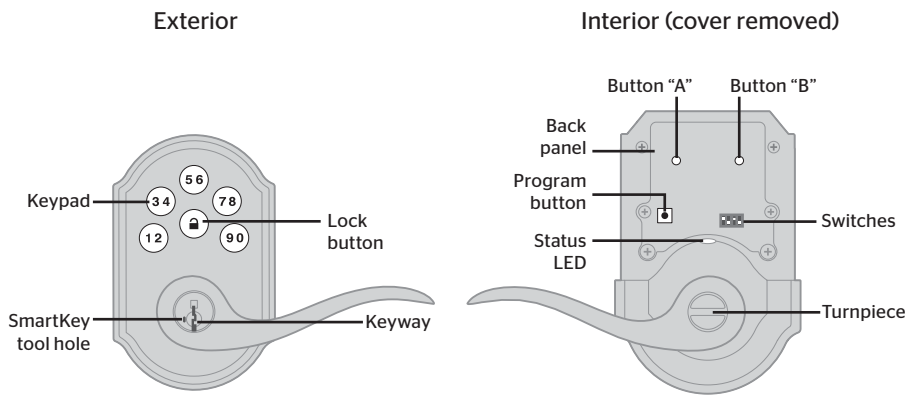

System Alerts

Alert	Reason	Solution
Keypad flashes red 1 time with 1 beep*	Door jammed while attempting to lock.	Manually re-lock door. If needed, reposition strike.
Keypad flashes red 3 times with 3 beeps*	Unsuccessful programming.	Attempt programming procedure again.
	One incorrect code entered.	Re-enter code.
	No user code programmed.	Program at least one user code.
Keypad flashes red 10 times with 10 beeps*	Low battery.	Replace batteries.
Lock beeps 2 times.	Programming timeout.	Attempt programming procedure again, making sure not to pause for more than 5 seconds.
Keypad flashes red 3 times.		
Keypad flashes red 6 times with 6 beeps*.		
Keypad flashes red 15 times with 15 beeps*	Three incorrect codes entered within one minute.	Re-enter code after 60 second keypad lockout.

*Beeping sound will only be heard if switch #3 is on.

Switches and Status LED colors

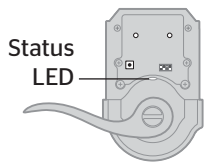
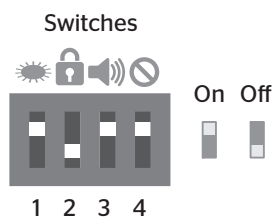

Switch	Function
1	Door lock status LED blinks every 6 seconds
2	Lock automatically re-locks door 30 seconds after unlocking. Disabled if no codes are programmed.
3	Audio
4	Not used.

Color	Lock Status
Green	Unlocked
Amber	Locked
Red	Low battery

Deleting a user code

In order to delete a user code, you must override the code by adding a different user code in the same position. For example, if you want to delete the third code, add a different user code in position three.

⚠ Test the old user code to make sure it can no longer unlock the door.

If you cannot remember the user code position, you may wish to perform a factory reset to delete all codes associated with the lock.

Troubleshooting

A complete Programming and Troubleshooting Guide is available on the SmartCode 912 page at www.kwikset.com.

Battery Replacement

If another lock is installed above the lever, remove the interior assembly when battery replacement is required.

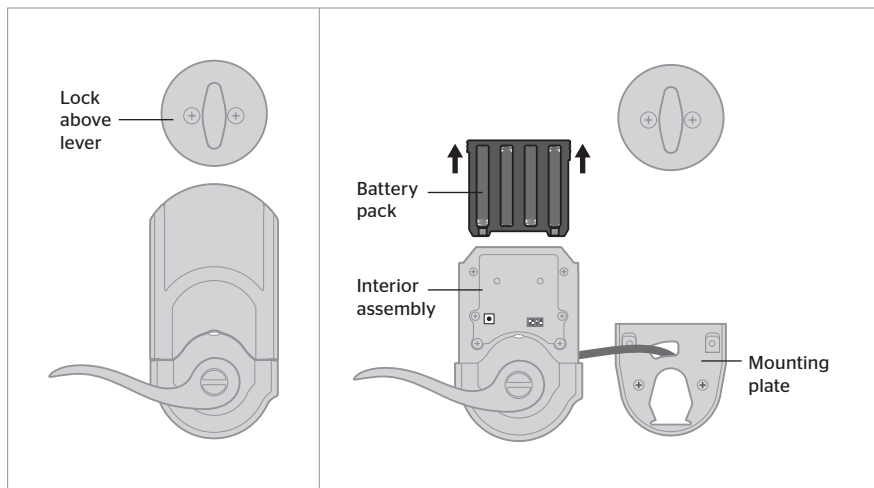

Factory Reset

A factory reset will delete all codes associated with the lock, and it will remove it from your smart home system.

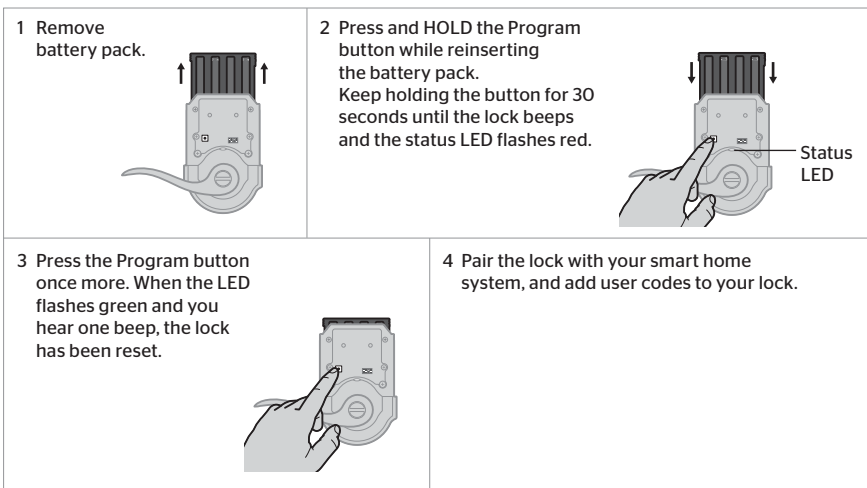

Network Information

Removing the lock from the network

Follow your smart home system's instructions to remove the lock from the network. When prompted by the system, press button A" on the lock interior once.

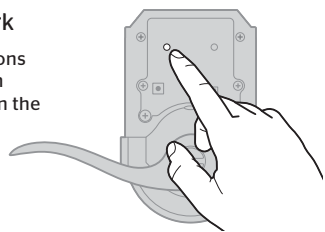

Z-Wave System Notes

This product is a security enabled Z-wave Plus product and must be used with a Security Enabled Z-Wave controller to be fully utilized. Z-Wave is a "Wireless mesh network," and results may vary based on building construction and communication path, with 35 feet+ being typical installed distance from smart home controller. It may be necessary to install additional Z-Wave beaming capable devices that can serve as repeaters to enhance the communication path between the lock and controller for a more robust Z-Wave network.

To assure interoperability, each Z-Wave product must pass a stringent conformance test to assure that it meets the Z-Wave standard for complete compliance with all other devices and controls. The Z-Wave identity mark assures consumers, integrators, dealers and manufacturers that their products will reliably perform with any other Z-Wave device. And, regardless of the vendor, always powered nodes may act as a repeater for Kwikset/Weiser/Baldwin products.

Z-Wave Configuration and Association Parameters are available on the SmartCode 912 page at www.kwikset.com.

Important Safeguards

1. Read all instructions in their entirety.
2. Familiarize yourself with all warning and caution statements.
3. Remind all family members of safety precautions.
4. Protect your user codes and mastercode.
5. Dispose of used batteries according to local laws and regulations.

⚠ **CAUTION:** Prevent unauthorized entry. Since anyone with access to the back panel can change the user codes, you must restrict access to the back panel and routinely check the user codes to ensure they have not been altered without your knowledge. The use of a mastercode can help protect your system's settings.

⚠ **WARNING:** This Manufacturer advises that no lock can provide complete security by itself. This lock may be defeated by forcible or technical means, or evaded by entry elsewhere on the property. No lock can substitute for caution, awareness of your environment, and common sense. Builder's hardware is available in multiple performance grades to suit the application. In order to enhance security and reduce risk, you should consult a qualified locksmith or other security professional.