

Triple Touch Lock Feature

This is a convenient feature that allows you to touch the Kevo lock three times to lock it without the use of a smartphone or fob. You might use this feature if you are using only a standard key in your system but wish to lock the door by touch, if your smartphone or Kevo fob is disabled, or if you have a visitor in your home that will leave and lock the door behind them. To lock the door with this feature, touch the deadbolt rose three times, pausing about a second between each touch. The light ring will spin blue, flash amber, and you will hear one beep. The door will lock.

Note: This feature is OFF by default. To enable this feature, flip the Triple Touch Lock switch to the ON position.

CAUTION: With this feature enabled, you may lock yourself outside if you don't have an enrolled smartphone, Kevo fob or standard key with you.

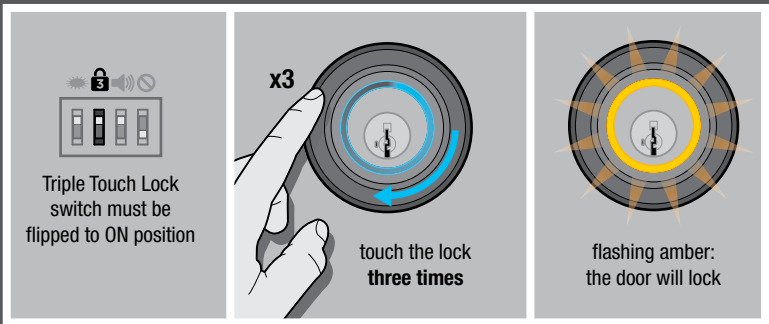

Error Notifications

If the Kevo lock flashes magenta and will not lock or unlock, even though you have your smartphone or fob in your pocket or purse, this means the Kevo lock senses your device is out of activation range. Move your device closer to the Kevo lock and try to lock/unlock the door again. If this is a consistent issue, perform the calibration process. For Kevo fob calibration, see page 9. For smartphone calibration, use the Kevo app.

Note: Activation range refers to the area around your Kevo lock in which the lock can detect your phone or fob and respond to touch. The calibration process can help fine tune this range.

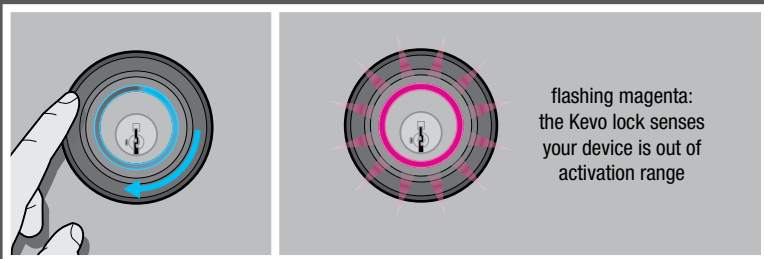

If the door locks or unlocks as intended, but you also hear a long beep and the lights on the outside of the Kevo lock flash red, you may have a low battery somewhere in your system or the deadbolt is jammed. Use the chart below to determine the problem. See page 18 for battery replacement instructions. If the deadbolt is jammed, check your door for alignment and make sure the latch bolt can operate smoothly.











Note: This chart is also located on the interior battery cover.











| | | | | |
|--|----------|--|--|--|
| | <p>=</p> | | | <p>replace AA batteries in lock interior</p> |
| | <p>=</p> | | | <p>replace fob battery</p> |
| | <p>=</p> | | | <p>deadbolt jam</p> |

chart located on
interior battery cover

AUDIO/VISUAL FEEDBACK

The following chart summarizes the meanings of the different sounds and lights that come from the Kevo system.

| Light Behavior | | Audio | Operation/Notification |
|---|-------------------|--|--|
|  | spinning blue | none | initial touch |
| | | | thinking |
|  | spinning green | none | smartphone or fob calibration touch sequence in progress |
|  | solid green | none | smartphone or fob calibration touch sequence in progress |
|  | flashing green x2 |  2 beeps | Kevo recognizes the user's smartphone or fob and unlocks |
| | | | smartphone or fob calibration complete |
|  | flashing amber x1 |  1 beep | Kevo recognizes the user's smartphone or fob and locks |
| | | | Kevo locks after Triple Touch Lock (if feature is enabled) |
|  | spinning amber |  1 beep | Kevo booting up after reset or battery change |
|  | flashing magenta | none | <p>When touched, Kevo communicates with smartphone or fob, but the device is out of activation range.</p> <p>Perform the calibration process to help the lock better communicate with your device.</p> |

| Light Behavior | | Audio | Operation/Notification |
|---|------------------------------------|---|--|
|  | quick flashing red | none | unauthorized user — Kevo will not unlock |
| | flashing red |  3 sec | general error notification, followed by one of three scenarios below |
|  | top two LEDs solid red | none | low AA batteries in deadbolt interior |
|  | bottom LED solid red | none | low battery in fob |
|  | side LEDs alternating flashing red | none | deadbolt jam |
|  | flashing green | none | fob enrollment in progress or Kevo recognizes fob during lock/unlock |
| | solid green |  2 beeps from lock | fob enrollment successful or powering up |
|  | solid red | none | fob setup failure |
| | flashing red | none | low battery in fob |
|  | flashing green | none | Kevo is unlocked |
|  | flashing amber | none | Kevo is locked |
|  | flashing red | none | low AA batteries in deadbolt interior |

BATTERY REPLACEMENT

Fob

To replace the battery in the Kevo fob, perform the following procedure.

1

Use a small coin to twist and pry apart the two halves of the fob.

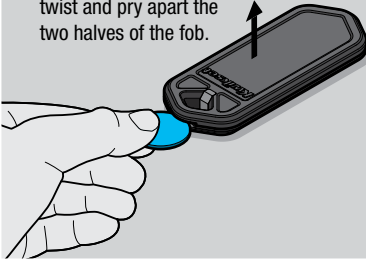

2

Slide battery out from between the two contacts.

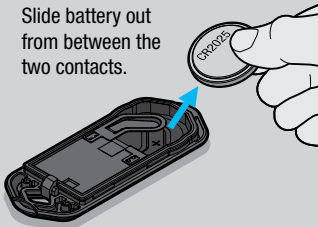

Dispose of battery according to local laws and regulations.

3

Insert a new CR2025 battery, sliding it between the two contacts so that the positive face of the battery touches the positive contact.

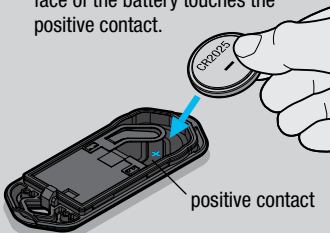

Press the two halves of the fob back together, making sure they snap into place.

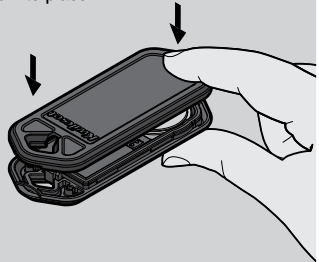

Deadbolt

To replace the batteries in the deadbolt, perform the following procedure.

1

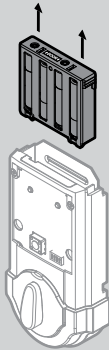

Dispose of batteries according to local laws and regulations.



2

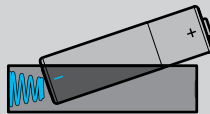
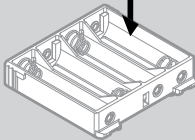
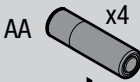

⚠ Ensure correct polarity.

3

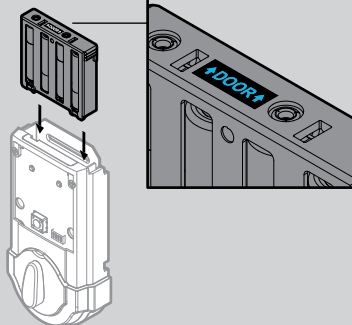

TROUBLESHOOTING



A complete troubleshooting guide is available at
www.kwikset.com/kevo/setup

SYSTEM UPDATES

As new firmware and app releases become available, the Kevo lock will receive over-the-air updates. The light ring will spin blue during these updates.

With these updates, we will continue to enhance your Kevo experience so you can enjoy all the benefits of advanced keyless entry.

REGULATORY COMPLIANCE

This product complies with standards established by the following regulatory bodies:

- Federal Communications Commission (FCC)
- Industry Canada

FCC

This device complies with Part 15 of the FCC Rules. Operation is subject to the following two conditions: (1) this device may not cause harmful interference, and (2) this device must accept any interference received, including interference that may cause undesired operation.

This equipment has been tested and found to comply with the limits for a Class B digital device, pursuant to Part 15 of the FCC Rules. These limits are designed to provide reasonable protection against harmful interference in a residential installation. This equipment generates, uses, and can radiate radio frequency energy and, if not installed and used in accordance with the instructions, may cause harmful interference to radio communications. However, there is no guarantee that interference will not occur in a particular installation. If this equipment does cause harmful interference to radio or television reception, which can be determined by turning the equipment off and on, the user is encouraged to try to correct the interference by one or more of the following measures:

- Reorient or relocate the receiving antenna.
- Increase the separation between the equipment and receiver.
- Connect the equipment into an outlet on a circuit different from that to which the receiver is connected.
- Consult the dealer or an experienced radio/TV technician for help.

IMPORTANT! Changes or modifications not expressly approved by the manufacturer could void the user's authority to operate the equipment.

Industry Canada

This Class B digital apparatus complies with Canada ICES-003. CAN/CSA-C22.2 NO. 14-05 (Industrial Control Equipment) Operation is subject to the following two conditions: (1) this device may not cause interference, and (2) this device must accept any interference, including interference that may cause undesired operation of the device.

Please contact customer service for all your Kevo questions and concerns:

Kwikset
1-800-327-5625, USA and Canada
www.kwikset.com

 **CAUTION:** Prevent unauthorized entry. Because anyone with access to the back panel can change your Kevo lock's settings, you must restrict access to the back panel and routinely check your settings to assure they have not been altered without your knowledge.

 **WARNING:** This Manufacturer advises that no lock can provide complete security by itself. This lock may be defeated by forcible or technical means, or evaded by entry elsewhere on the property. No lock can substitute for caution, awareness of your environment, and common sense. Builder's hardware is available in multiple performance grades to suit the application. In order to enhance security and reduce risk, you should consult a qualified locksmith or other security professional.